

Visibility Laboratory
University of California
Scripps Institution of Oceanography
San Diego 52, California

FEASIBILITY STUDY OF A PHOTOELECTRIC SYSTEM
FOR DETECTION OF DOWNED AVIATORS

Richard L. Ensminger
James L. Harris

June 1960
Index Number NS 714-100

SIO REFERENCE 60-45

Bureau of Ships
Contract NObs-72092

Project S FO01 05 01

Approved:

Approved for Distribution:



Seibert Q. Duntley, Director
Visibility Laboratory

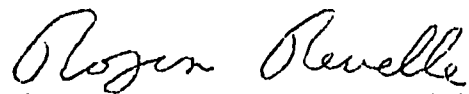

Roger Revelle, Director
Scripps Institution
of Oceanography

FEASIBILITY STUDY OF A PHOTOELECTRIC SYSTEM
FOR DETECTION OF DOWNED AVIATORS

1.0 Introduction

The Navy has, for some time, been actively interested in the use of searchlights and retroreflective materials as an aid in search and rescue operations associated with aviators downed at sea. Reference 1 reports field tests of such operations.

For a number of years the Visibility Laboratory has carried on a program of investigation of the applicability of photoelectric instrumentation to a variety of military search, detection, and identification tasks. Because of this background, the Visibility Laboratory was requested, by the Navy, to study the feasibility of the design and construction of specialized photoelectric apparatus for this air rescue task. The feasibility study has been completed and the results are reported in this document.

2.0 Scope of the Report

The function of a photoelectric system should be to improve upon the performance capabilities of unaided visual search. This report will therefore start with a very brief analysis of the visual detection capability. Succeeding sections of the report will discuss each parameter of the search geometry and indicate, where possible, modification of the parameter which will lead to improved performance. The final sections

1. J. W. Lane, Sr., T. H. Projector, W. A. Hall, L. R. Noffsinger, "Evaluation Field Tests of Searchlight and Reflective Materials in Search and Rescue Operations," National Bureau of Standards Report 4606, April, 1956.

will describe a photoelectric system capable of incorporating the improvements indicated in the paragraphs which precede it and capable of day and night operation at a performance level surpassing the specified Navy requirements.

3.0 Visual Detection of Downed Aviators

While reference 1 describes a number of searchlights used for the field tests, the Navy specified, for the purpose of this study, that a typical searchlight would be one of 4,000,000 beam candlepower and a beam spread of 8° horizontally and 3° vertically.

A retroreflective material is to be mounted on the pilot's helmet. The Navy has used "Scotchlite" tape and the "Stimsonite" #10, red buttons.

The Navy has specified that the requirement is for $\frac{1}{2}$ nautical mile detection range at search altitudes no greater than 1000 feet, and atmospheric transmission of no less than 0.6 per sea mile.

3.1 Calculation of Veiling Luminance

The visual observer sees the target through a veiling luminance created by the backscattering of the searchlight. Reference 2 contains a derivation of an equation for the veiling luminance. For the purposes of simplifying the analysis it was assumed that the intensity of the searchlight had a peak value, I_0 , on the optical axis and which decreased linearly with angle until it reached a value of $0.1 I_0$, at which point it

2. H. R. Blackwell, S. C. Duntley, and W. M. Kincaid, "Characteristics of Tank-Mounted Searchlights for Detection of Ground Targets," Work Group on Tank Searchlights, Armed Forces-National Research Council Vision Committee, University of Michigan, 1953.

dropped abruptly to zero. With these simplifying assumptions the veiling luminance for line of sight along the optical axis can be approximated to within 10% by the equation

$$B_V = \frac{0.247 I_0 \phi}{vd} \quad (1)$$

where I_0 is the peak intensity of the searchlight, ϕ is the half beam width in radians, v is the meteorological range in feet, and d is the separation between source and observer in feet. A plot of equation (1) is shown in figure 1 with meteorological range as a variable and in figure 2 with source-observer separation as a variable.

3.2 Calculation of Sea Luminance

The peak illuminance of the sea surface, neglecting multi-path transmission, at a range R due to the searchlight is

$$E_S = \frac{I_0 e^{-\frac{3.912 R}{v}}}{R^2} \quad (2)$$

Since the searchlight beam will be striking the water at angles near the horizontal, the return from smooth water will be small. The largest value of sea background luminance would probably result from "white water". If the white water is considered to be a Lambert surface, then the inherent white water luminance would be

$$B_S = r_S E_S \quad (3)$$

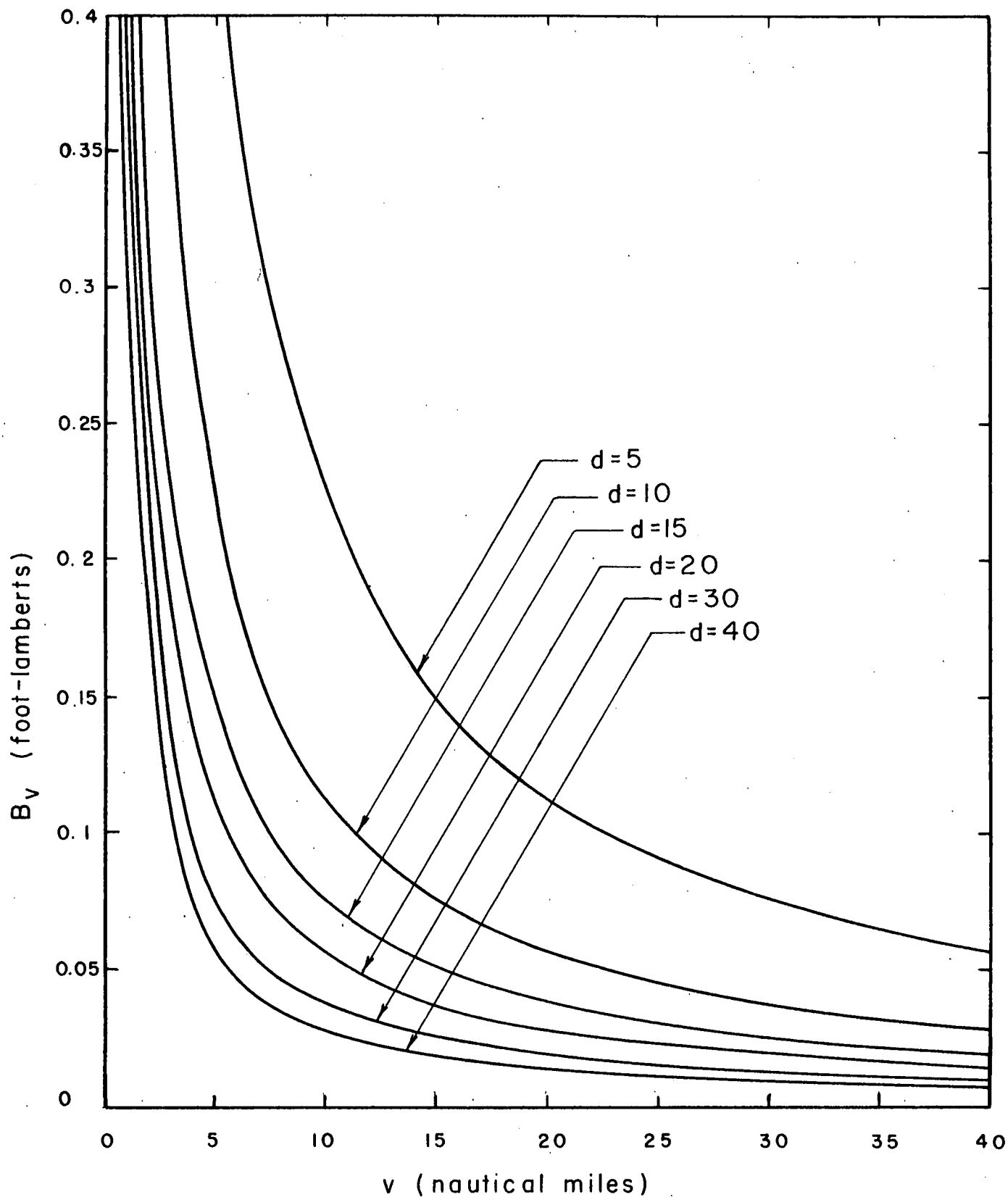

Figure 1. The relationship between veiling luminance and meteorological range for selected values of source-observer separation.

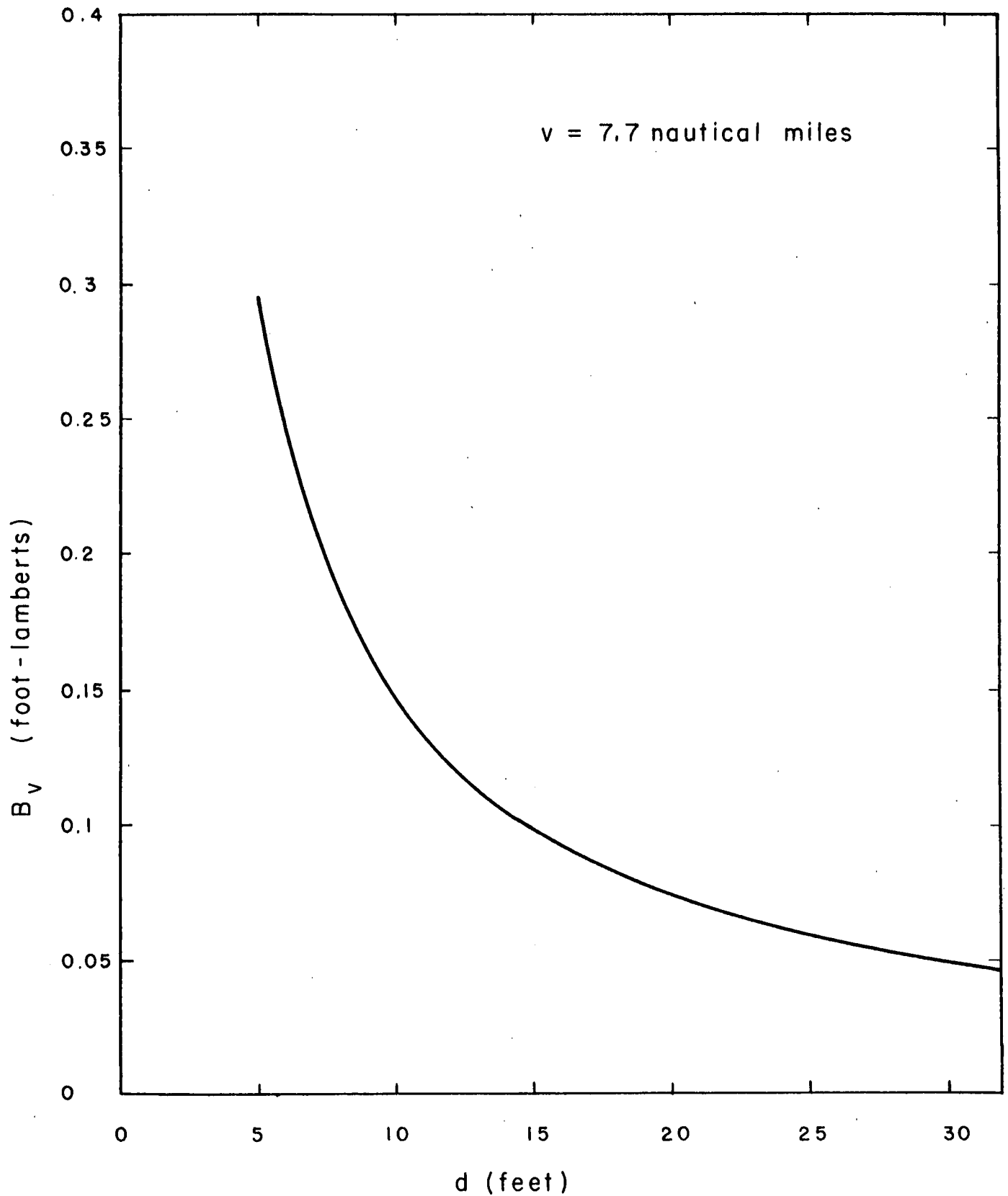

Figure 2. The relationship between veiling luminance and source-observer separation.

or

$$B_S = \frac{r_S I_o e}{R^2} - \frac{3.912 R}{v} \quad (4)$$

The apparent white water luminance as viewed by the observer is

$$B_{SR} = \frac{r_S I_o e}{R^2} - \frac{3.912 (2R)}{v} \quad (5)$$

Figure 3 shows a plot of equation (5).

3.3 Total Background Luminance -- Nighttime

The total background luminance is the sum of the veiling luminance and the white water luminance or

$$B_T = \frac{0.247 I_o \phi}{vd} + \frac{r_S I_o e}{R^2} - \frac{7.824 R}{v} \quad (6)$$

3.4 Luminance of a Scotchlite Helmet

Retroreflectors have the property of returning a large portion of the incident flux back along the same path followed by the incident flux. One way of describing the efficiency of a retroreflector is to specify its specific brightness. Specific brightness is the brightness per unit of illuminance. This is frequently given the dimensions of candles per square foot per foot-candle. For the purpose of this report it is more convenient to use the dimensions of foot-lamberts per foot-candle. For a lambert surface of unity reflectance and an illuminance of

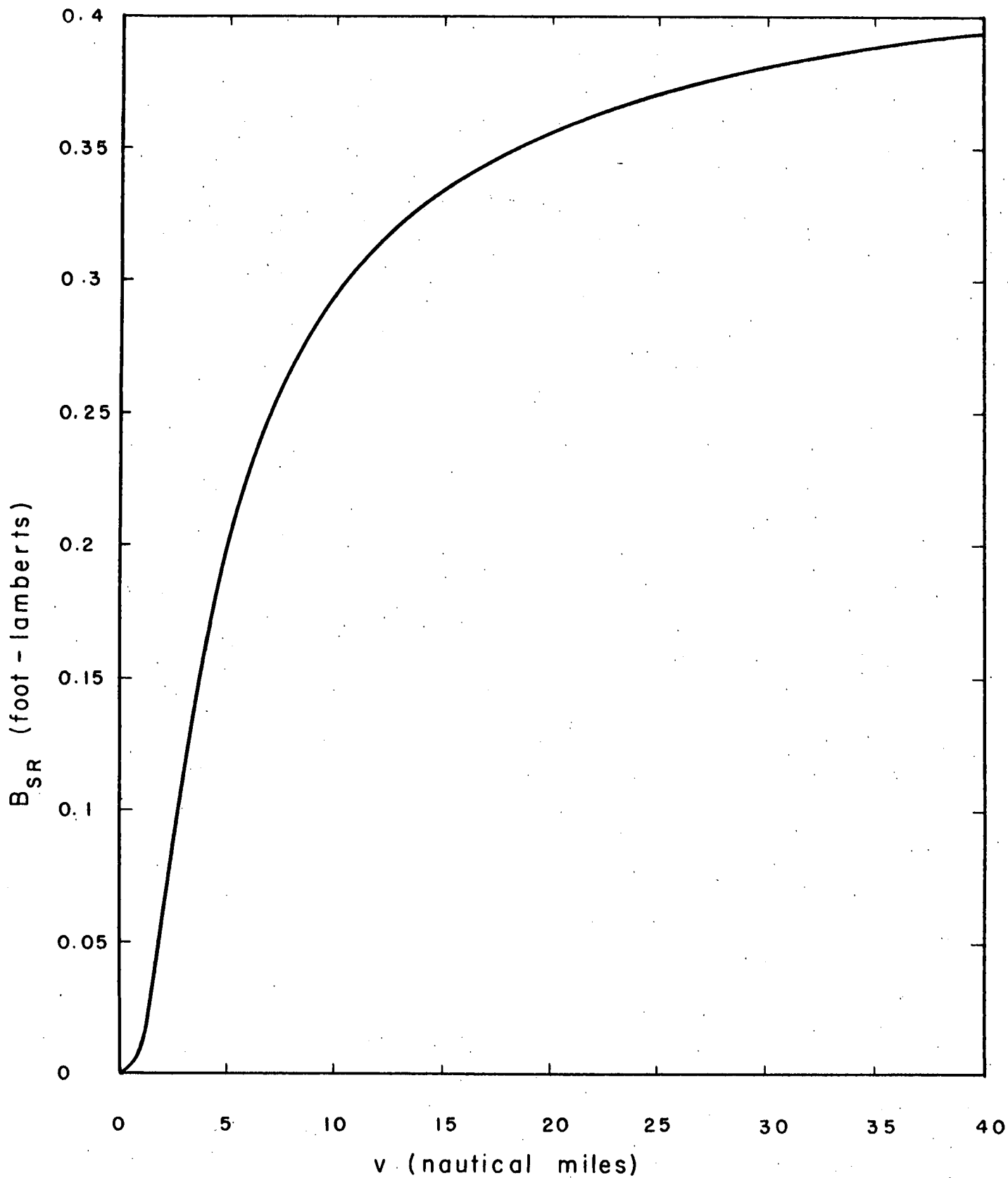

Figure 3. The relationship between white water luminance and meteorological range.

one foot-candle the brightness would be one foot-lambert. Thus the specific brightness, when expressed in foot-lamberts per foot-candle is unity for an ideal lambert surface. Measurements at this laboratory indicated red Scotchlite has a specific brightness on the order of 22 foot-lamberts per foot-candle. This means then, that for small separations of source and observer, red Scotchlite viewed normal to the surface would appear to be 22 times as bright as an ideal lambert surface. The specific brightness of the material decreases with increasing source-observer separation and increasing angular departure from normal viewing. For a spherical helmet viewed with small source-observer separation the average specific brightness is approximately 10% of the peak specific brightness because of the fall-off of the non-normal surface area. The average specific brightness of a Scotchlite helmet would therefore be on the order of 2.2 foot-lamberts per foot-candle.

Denoting \bar{r}_H as the average specific brightness of the helmet, the average helmet brightness is

$$\bar{B}_H = \frac{\bar{r}_H I_o e^{-\frac{3.912 R}{v}}}{R^2} \quad (7)$$

and the average apparent brightness of the helmet is

$$\bar{B}_{HR} = \bar{r}_H \frac{I_o e^{-\frac{7.824 R}{v}}}{R^2} \quad (8)$$

3.5 Calculation of Detection Range -- Nighttime

From Sections 3.3 and 3.4 the contrast of the helmet can be found to be

$$C_{HR} = \frac{\bar{B}_{HR} - B_{SR}}{B_V + B_{SR}} \quad (9)$$

or

$$C_{HR} = \frac{\frac{\bar{r}_H I_o e^{-\frac{7.824 R}{v}}}{R^2} - \frac{r_S I_o e^{-\frac{7.824 R}{v}}}{R^2}}{\frac{0.247 I_o \phi}{vd} + \frac{r_S I_o e^{-\frac{7.824 R}{v}}}{R^2}} \quad (10)$$

This may be rewritten as

$$C_{HR} = \frac{\bar{r}_H - r_S}{\frac{0.247 R^2 \phi}{vd e^{-\frac{7.824 R}{v}}} + r_S} \quad (11)$$

which it may be noted, is independent of I_o . The detection range is not, however, independent of I_o because the contrast threshold for a visual observer is a function of the adaptation luminance. It should be remembered that \bar{r}_H is a function of d , the source-observer separation. A plot of equation (11) is shown in figure 4 with meteorological range as the independent variable, and a sea reflectance value of zero. Figure 5 is the same plot for a sea reflectance of unity. On the same graph of

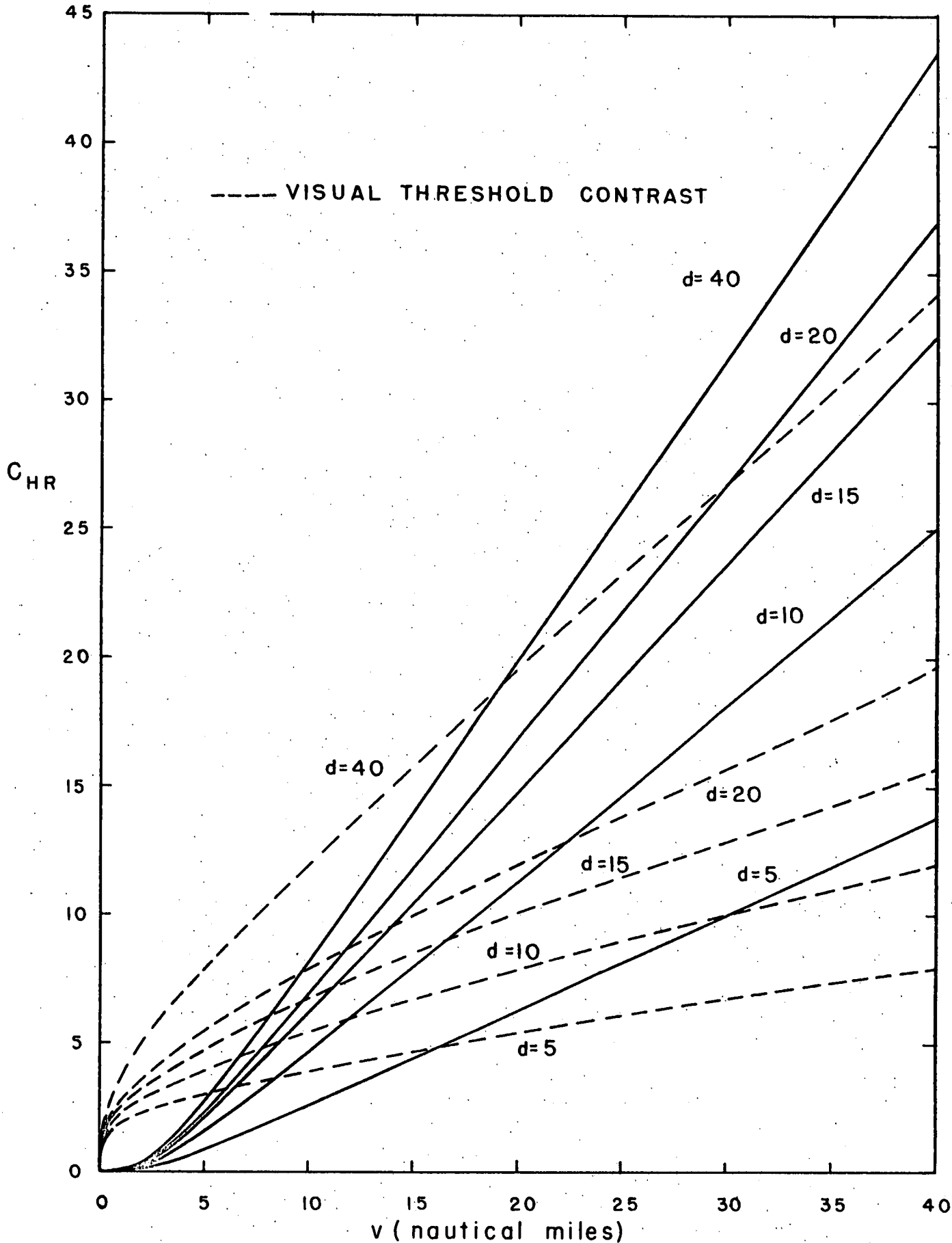

Figure 4. The relationship between helmet contrast and meteorological range for selected values of source-observer separation and for a sea reflectance of zero. Also shown is the visual contrast threshold as a function of meteorological range.

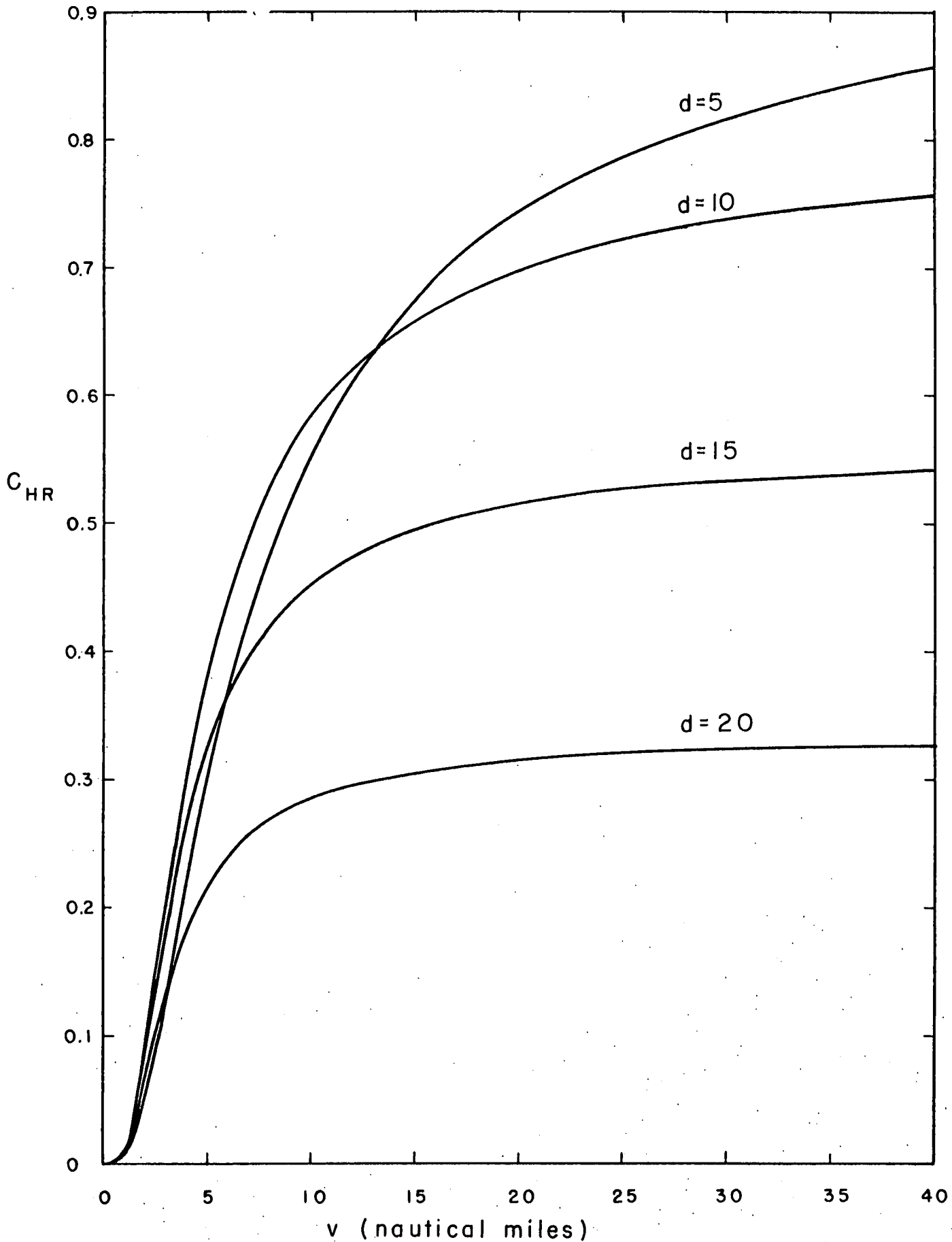

Figure 5. The relationship between helmet contrast and meteorological range for selected values of source-observer separation and for a sea reflectance value of unity.

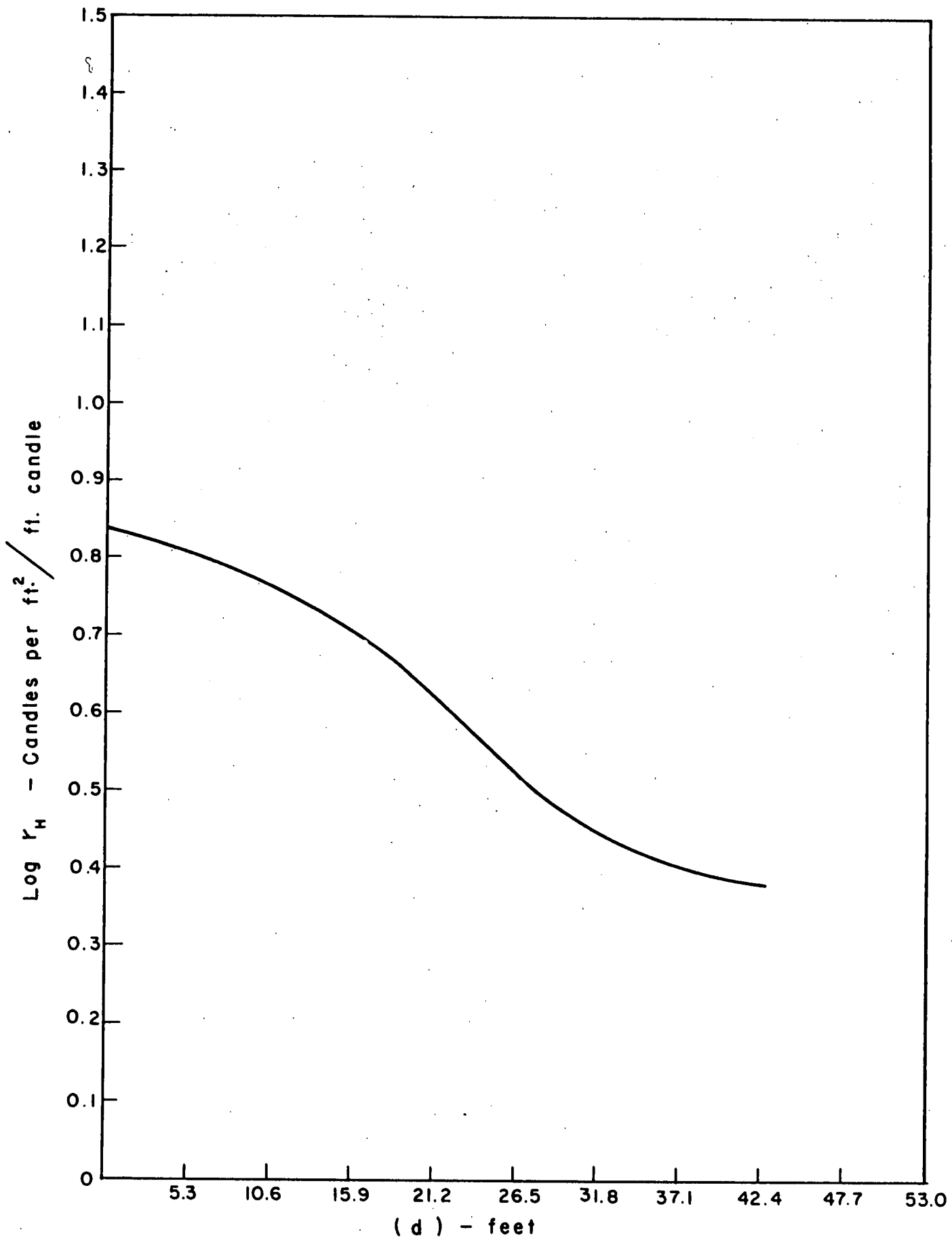

Figure 5A. Plot of specific brightness of red Scotchlite as a function of separation distance (d) between light source and observer for a 0.5 nautical mile range.

figure 4 the visual contrast threshold is also plotted. Because of the decrease in veiling luminance (i.e., adaptation level) with increase in meteorological range, the contrast threshold increases slightly. It should be noted that the contrast threshold does not rise nearly as rapidly as the apparent contrast of the helmet.

Figures 4 and 5 indicate the results of the simplified visual calculation. The purpose of this calculation is to indicate the order of magnitude of visual performance achievable with a searchlight and Scotchlite helmet. The calculation indicates marginal performance except at the highest meteorological range. This forms a basis for recommendations contained in the sections which follow.

4.0 Retroreflective Materials

The field tests, described in reference 1, utilized a variety of retroreflective materials, the most promising of which seemed to be red Scotchlite tape, and the red Stimsonite #10 retroreflector buttons. Since the time of these field tests, much improved materials have become available.

A reasonable first step in studying possible improvements in the air-sea rescue system is to examine the available materials and compare the performance capabilities of each.

4.1 Measurements Performed

An optical setup was constructed which allowed direct measurement of specific brightness. Eight different types of retroreflective material were selected for measurement. These consisted of green, white, red, and yellow sheet material produced by Shannon Luminous Materials;

red Scotchlite tape produced by Minnesota Mining and Manufacturing; and red #10, neutral #21, and neutral (experimental hexagonal) produced by Stimsonite. The results of the measurements are shown in figure 6. The ordinate is the logarithm to the base 10 of the specific brightness and the abscissa is the angular displacement between the source and the observer.

One additional measurement was required for the analysis. As indicated in an earlier section in this report, the specific brightness decreases as the material is rotated away from a position perpendicular to the line of sight (i.e., normal). Figure 7 is a sample of the measurements of this property of the retroreflectors. Each of the curves are labeled with an angle which is the departure from normal viewing. For a 10-inch diameter spherical helmet the effect of this fall-off in specific brightness is to make the average helmet brightness equal to approximately 10% of the value calculated for a piece of material equal to the helmet projected area and viewed normal to the material.

4.2 Significance of the Measurements

Reference to figure 6 indicates that the specific brightness of the various materials differs by more than a ratio of 10,000 to 1. For example the Stimsonite experimental hexagons have a specific brightness roughly 3,000 times that of the red Scotchlite. Reference to equation 11 shows that the use of this superior material would result in an increase in contrast by a factor of 3000 for low sea reflectances and approaching 6000 for high sea reflectances.

While it is recognized that the Scotchlite tape is easily the most convenient of the materials studied as far as ease of application to

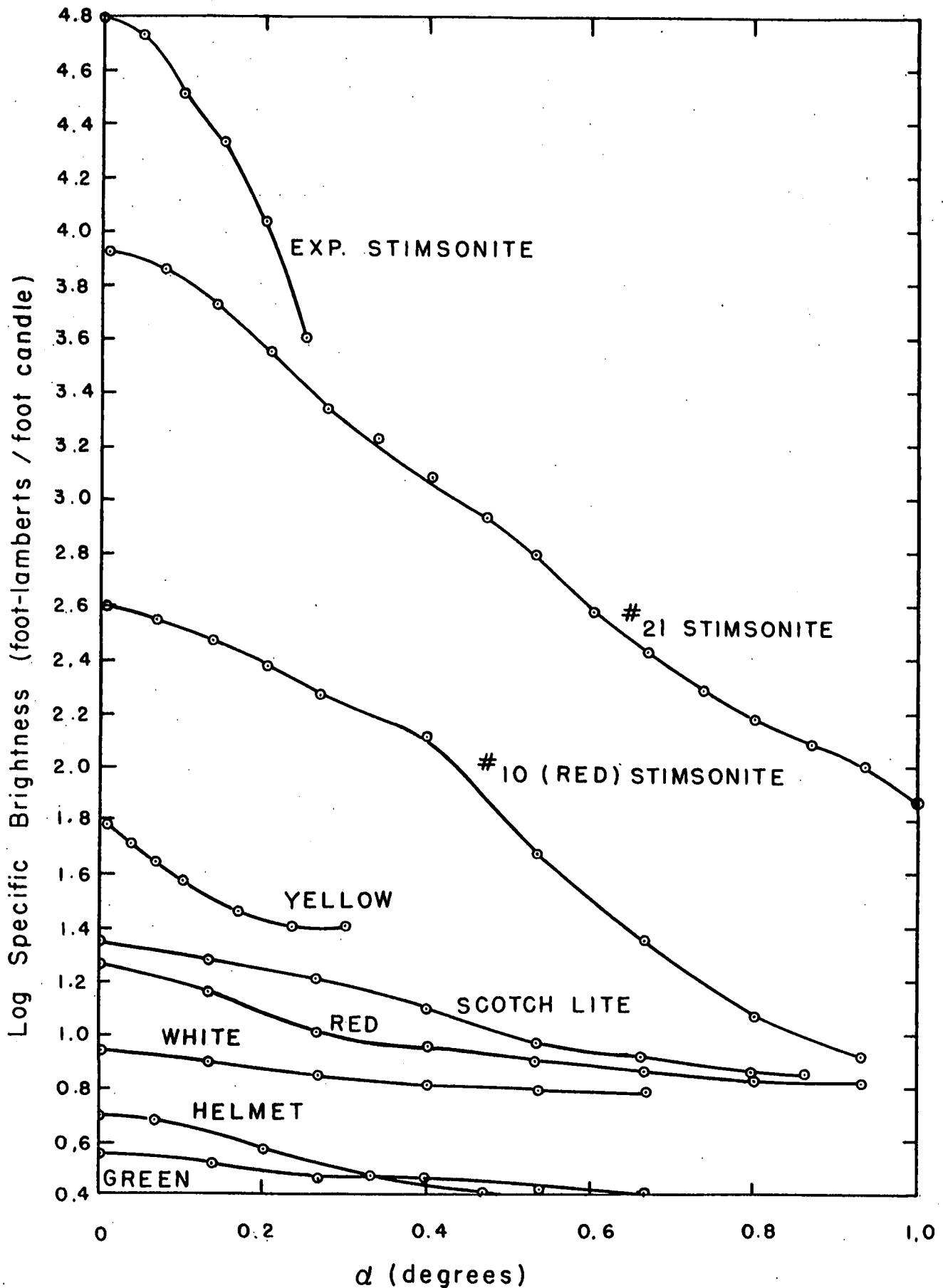

Figure 6. Measured data relating specific brightness to the angular displacement between source and observer.

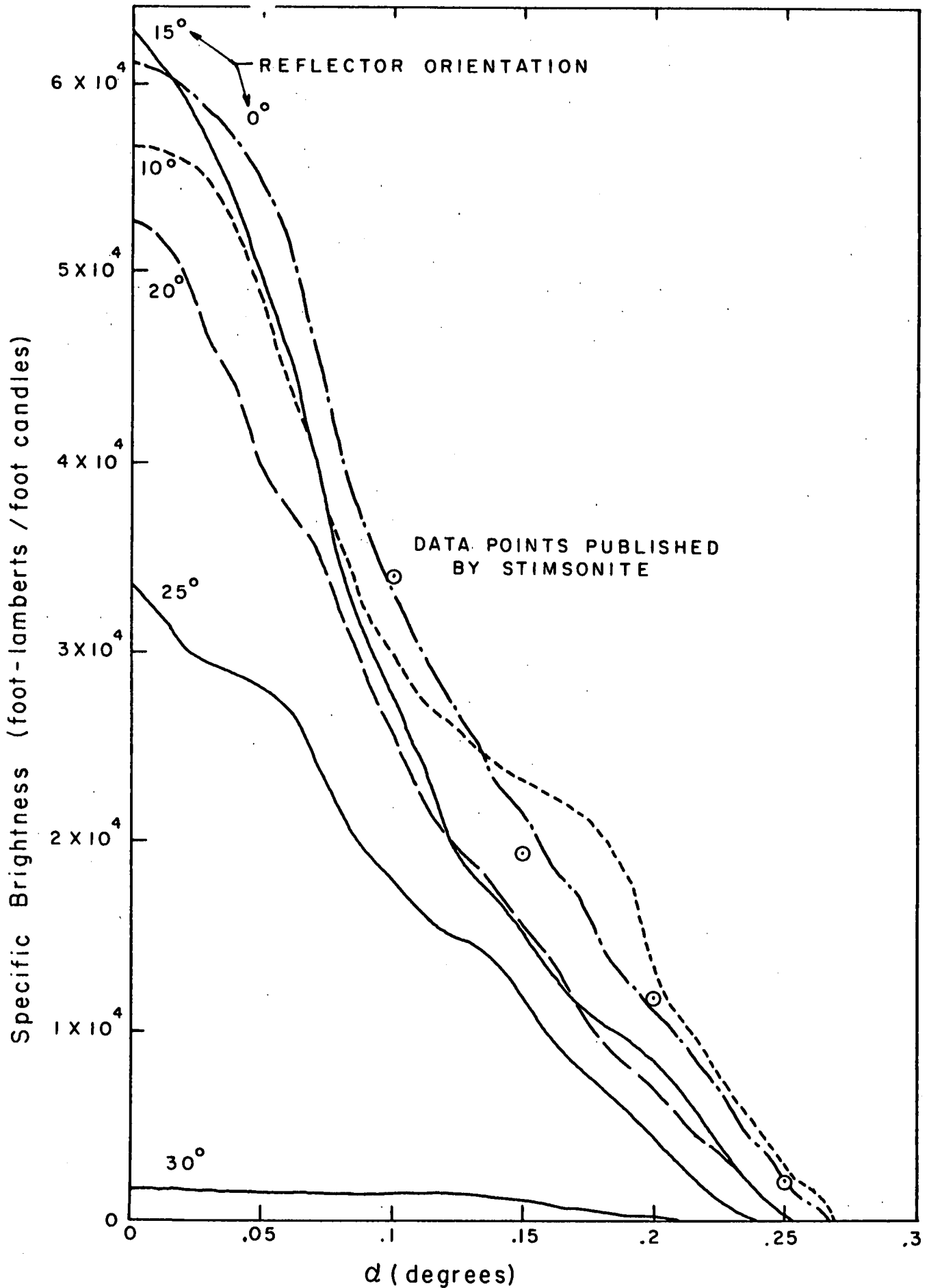

Figure 7. Measured data relating specific brightness to the angular deviation of the retroreflective material from normal viewing.

a helmet, the very dramatic potential gains achievable with the Stimsonite hexagonal buttons cannot be set aside by such simple considerations. The gains achievable with the high quality retroreflectors amply justify a program of investigation of methods of mounting, field maintenance, and pilot safety considerations.

Figure 8 is a non-quantitative demonstration of the relative performance of the various materials. Four samples were placed on the roof of a building 2160 feet distant and photographed while illuminated with a one million beam candlepower searchlight. The targets are left to right: a helmet covered with red Scotchlite, a helmet with red Stimsonite #10 buttons, a single piece of Stimsonite #21, and a helmet covered with Stimsonite #21. The hexagonal Stimsonite buttons were not available at the time of the test. They have a specific brightness approximately 5 times that of the Stimsonite #21.

The Visibility Laboratory has mounted Stimsonite hexagonal buttons on a Navy helmet and returned the helmet to the funding agency in Washington for examination. It must be clearly understood that the buttons were mounted on this helmet by this laboratory for the sole purpose of determining the optical properties of such a modified helmet. The technique of mounting was chosen for this purpose only and not on the basis of durability, field maintenance, or pilot safety. Failure of this modified helmet to meet physical requirements does not constitute valid criticism. It is strongly recommended that the Navy initiate a program of investigation to determine mounting techniques which will satisfy physical requirements for durability, field maintenance, and pilot safety.

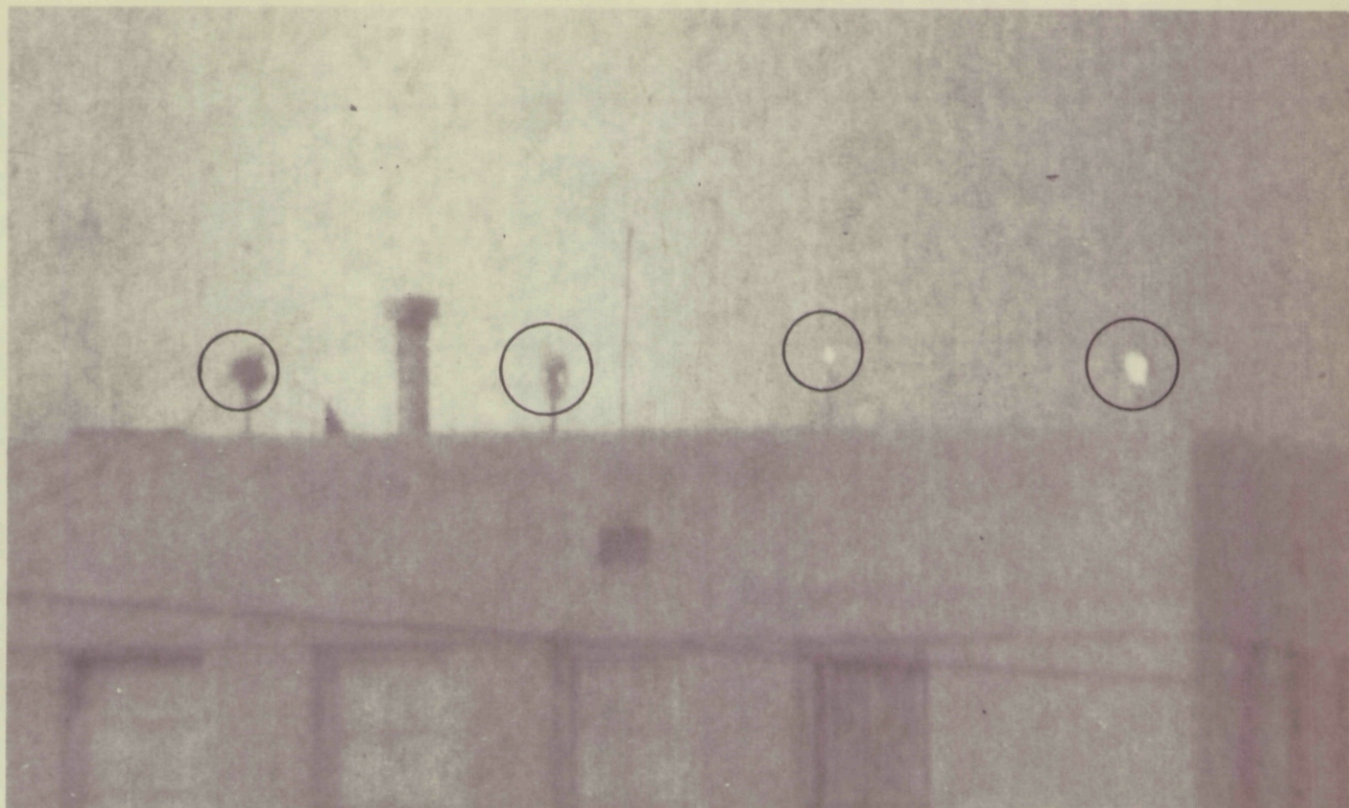

Figure 8. A photograph of the four targets at dusk 2160 feet away. The illumination source is a one million beam candlepower searchlight.

5.0 Backscatter Reduction Techniques

The preceding section described a first and very dramatic improvement in system performance by the use of retroreflective materials of very high quality. Another factor which effects the apparent contrast of the helmet as viewed from the searching aircraft is the veiling luminance due to searchlight backscatter. There are a number of possible techniques for the reduction of veiling luminance.

5.1 Polarization Techniques

One possible method of reducing the veiling luminance is described in reference 3. This would involve polarizing the searchlight and cross polarizing the returned flux at the receiver. Reference 3 indicates that the backscattered flux from the searchlight retains its initial polarization and the backscatter return is therefore sharply attenuated by the cross polarizer at the receiver. Since the flux returned from Scotchlite also retains the polarization of the incident flux, to a large degree, this return would be sharply attenuated by the cross polarizer at the receiver. Therefore in order to use the polarization technique with a Scotchlite target, an additional element must be added to the Scotchlite to cause a rotation of the E vector in the returned flux.

The Stimsonite hexagonal buttons have the property that the returned flux does not retain the linear polarization of the incident flux and they are therefore suitable for use in a polarized system without modification.

3. Alan M. Nathon, "A Polarization Technique for Seeing Through Fogs with Active Optical Systems," New York University, Technical Report 362.01, June, 1957.

The reduction in veiling luminance by means of polarization would appear to have many applications. It was not considered in detail in the course of this study for two reasons. First, reference to figure 1 indicates that, for the limiting conditions specified by the Navy, the veiling luminance may be of the same order of magnitude as the sea return. The polarization technique will not appreciably discriminate against the sea return and the transmission loss associated with real polarizers at both the searchlight and receiver must be considered.

The second, and more important, reason why a full study of the polarization technique was not made is that the photoelectric system selected for analysis eliminates backscatter in a most efficient manner and the polarization is therefore not required.

5.2 Pulsed Systems

If the light source in the system emits short pulses and the receiver is gated during the time in which the pulse is traveling away from the source, then the receiver does not respond to backscattered flux. A pulsed system offers an additional advantage of great importance. If it is assumed that there is an energy limitation on the source (power consumption over the period of the search flight), high peak powers can be obtained by emitting energy for only brief periods of time. If the receiver is gated to match the transmitted pulse, then the energy received from the ambient light in the scene is proportional to the gate time. Thus as the pulse is made shorter in time, maintaining constant pulse energy, the ratio of pulse return energy to ambient received energy increases. This advantage will be amplified in the next section of this report.

6.0 Choice of a Photoelectric System

The purpose of this section is to outline some of the factors which dictate the type of photoelectric system to be recommended for the pilot recovery phase of the air-sea-rescue operation.

6.1 Retroreflector Choice

Section 4 of this report indicated the extremely large performance gains achievable with the Stimsonite experimental hexagonal buttons. These buttons offer an extremely important contribution to system performance and therefore constitute the first system choice.

6.2 Discrimination Technique

Size, color, and luminance of the helmet constitute possible bases for discrimination against false targets such as patches of white water. The use of the high quality retroreflector makes it possible to perform discrimination on the basis of luminance. This represents an important simplification to the system because amplitude discrimination is much easier to mechanize than either size or color. Amplitude discrimination will therefore be utilized and the retroreflectors will be neutral to insure maximum flux return from the helmet.

6.3 System Resolution

The retroreflective buttons will result in a high contrast target. The helmet does however present a small cross-section. To most efficiently utilize amplitude discrimination it is necessary that the helmet be resolved by the system. In a system having resolution much less than the angular subtense of the helmet it would be possible for a number of white water patches to contribute a total flux comparable to the helmet return. The helmet size and the specified detection range of $\frac{1}{2}$ nautical mile therefore specify the system resolution.

6.4 Desirability of a Pulsed Light System

With the high helmet contrasts achievable with the Stimsonite retroreflectors, a photoelectric system operating in conjunction with a searchlight can most certainly meet the Navy performance specifications for nighttime operation. Such a system would, however, be of no use for daytime operation. The retroreflective helmet will be of no help for visual search during daytime, and the search task of finding such a small target at sea remains a very serious problem.

The pulsed light system is the one system which offers the possibility of day-night operation with a single piece of equipment. This is an extremely strong advantage and it was therefore decided that the analysis of such a system should have high priority.

6.5 Choice of a Sensor

The requirement for high resolution and the desirability of a pulsed light system to provide day-night operation place strong limitations on the choice of a sensor for the system. High resolution implies scanning. A pulsed light system implies that all resolution elements in the field of view must be examined simultaneously during the short period of time of the pulse return. This requires either a separate detector for each resolution element or image storage of some type.

Both of these requirements can be most easily accomplished by the use of a television camera tube. An additional requirement is that the sensor be capable of gated operation, i.e., storage only during the brief period of the light pulse return.

The image orthicon satisfies all of these requirements. In addition it is the most sensitive of the visible spectrum sensors. There

is also the advantage that the image orthicon camera is widely used and there is a considerable industrial experience in packaging of image orthicon systems for aircraft applications.

For the reasons given above the image orthicon was selected as the best sensor for this particular application.

7.0 Outline of the System

The following is a simplified block diagram of the proposed system.

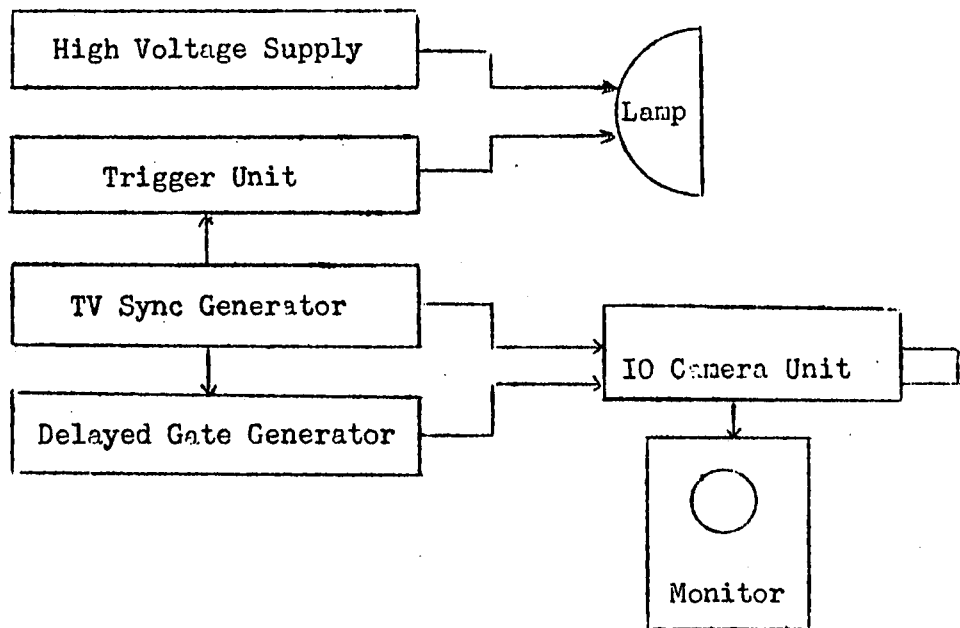

The pulsed lamp derives its trigger from the TV sync generator. The vertical sync pulse would be counted down with a 2-1 counter to give a 30-cycle trigger. The same signal would be fed to the gate generator where it would be delayed by the pulse travel time. Gate pulses would be supplied to the photocathode and/or accelerator grid of the image orthicon

so that there is no image storage except during the time interval associated with pulse return from the water's surface. The output of the camera unit would be fed to the monitor for display.

The field of view of the lamp and camera are coincident. This field of view would be made to sweep in azimuth while maintaining a fixed orientation with respect to the vertical axis. This very possibly would be done by deriving the sweep from a cam-driven mirror thereby allowing the camera and lamp to have a fixed mounting.

8.0 Numerical Example of System Performance

The following parameters will be assumed in order to test the performance capability of the system by numerical example.

Pulsed Lamp:	
Average Power	30 watts
Pulse Length	3 microseconds
Luminous Efficiency	35 lumens/watt
Beam Width	10 degrees
Pulse Repetition Rate	30 pulses/second
Retroreflectors	Stimsonite Experimental Hexagons
Helmet Coverage	50%
Image Orthicon	RCA 5820 or equivalent
Atmospheric Transmittance	0.6/nautical mile
Horizontal Range to Target	3000 feet
Altitude of Search Craft	1000 feet

As an indication that the pulsed lamp indicated above is within the state of the art, reference 4 describes the Spruce Light whose characteristics are listed as

4. "Descriptive Booklet Airborne Ranging Device Feasibility Test Unit," Engineering Report No. 245B, Farrand Optical Co., Inc., New York, June, 1954.

Average Power	47 watts
Pulse Length	0.3 microseconds
Pulse Repetition Rate	25 pulses/second

8.1 Illuminance of the Helmet

The total luminous flux emitted by the lamp during a single pulse is

$$F = \frac{\gamma P}{\tau p}, \quad (12)$$

where γ is the luminous efficiency of the source, P is the average electrical power, τ is the pulse length, and p is the pulse repetition rate. For the numerical values of section 8.0

$$F = 11.6 \times 10^6 \text{ lumens.} \quad (13)$$

The intensity of the source is

$$I = \frac{F}{\Omega}, \quad (14)$$

where Ω is the solid angle of the beam expressed in steradians. Therefore in this case

$$I = 4.84 \times 10^8 \text{ lumens/steradian.} \quad (15)$$

The illuminance at the helmet is

$$E_H = \frac{IT}{R^2}, \quad (16)$$

where T is the atmospheric transmittance and R is the range to the helmet. Numerically

$$E_H = 41.7 \text{ foot-candles} \quad (17)$$

8.2 Illuminance of the Image Orthicon Photocathode

In section 4 of this report the average specific brightness of a spherical helmet was found to be approximately 6000 foot-lamberts per foot-candle. It will be assumed that the helmet is 50% covered and that the average specific brightness is therefore 3000 foot-lamberts per foot-candle. The average luminance of the helmet is therefore

$$B_H = 125,100 \text{ foot-lamberts} \quad (18)$$

The image orthicon photocathode illuminance is

$$E_C = \frac{B_H T}{4(f/)^2} \quad (19)$$

where (f/) is the f- number of the camera objective lens. For the example given

$$E_C = \frac{24,250}{(f/)^2} \text{ foot-candles} \quad (20)$$

8.3 Characteristics of the Image Orthicon

Under conventional operation the 5820 image orthicon reaches a saturation level at a photocathode illuminance of 0.01 foot-candles. The saturation results from an integration over the full frame period of 1/30

second. For a 3-microsecond pulse the illuminance level producing saturation is larger by the ratio of the two times or

$$E_S = 111 \text{ foot-candles} \quad (21)$$

The f-number which would produce saturation on the helmet return is therefore

$$f/ = 14.8 \quad (22)$$

Under daylight conditions white water patches viewed from this angle might have apparent luminance values on the order of 1000 foot-lamberts. With an f/14.8 optical system the photocathode illuminance would be

$$E_{PC} = 1.144 \text{ foot-candles} \quad (23)$$

Thus the brightest objects in the field of view would appear on the monitor to be only 1/100 as bright as the helmet. Such a signal would be immersed in the system noise. Thus the monitor display could be made to be black in all regions except where a helmet exists. Under these conditions the signal-to-noise ratio would be expected to be on the order of 70, therefore giving highly reliable performance.

It may be noted that it might prove desirable to lengthen the gate pulse to include a period of time after the pulse return, in order to give a faint background picture for orientation purposes.

8.4 Area Search Considerations

As mentioned earlier in this report, the light source and camera would have coincidence of field of view and the field of view would be swept in azimuth maintaining a fixed orientation relative to the vertical.

For purposes of illustration it will be assumed that the unit is mounted on a fixed wing aircraft having a cruising speed of 180 knots (see figure 9). The 10-degree beam width will illuminate a patch on the water's surface which has a radial length of approximately 1880 feet. In order to use a conventional rectangular TV raster only 1290 feet of this illuminated area would be utilized.

Since the search aircraft has a speed of 180 knots (300 feet/sec) it requires 4.3 seconds to travel the 1290-foot distance. This means that if a particular azimuth has just been inspected, that azimuth need not be examined again for a period of 4.3 seconds. Since the frame period of the system is 1/30 second, 129 frames can be obtained in each azimuth sweep. The field of view in azimuth of the TV camera would be approximately 7 degrees, because of the desirability of using a rectangular raster which is inscribed within the circular pulsed lamp beam. If a 180-degree azimuth search is desired, then there are 25.7 independent beam positions in the full azimuth sweep. The 129 frames achievable in the azimuth sweep period indicate that each segment of the water can be observed 5 times. In the presence of a helmet the monitor display could therefore show a row of 5 bright equally-spaced dots or a single bright dot on each of five successive azimuth sweeps. This redundancy in search coupled with a long persistence CRT can serve a useful purpose. It represents a safety factor which would allow for possible occasional misfirings of the lamp, etc. In addition it minimizes the probability that the helmet will be undetected because of wave hiding action.

The search pattern outlined above covers a width of 1 mile at a forward velocity of 180 knots or an area search rate of 180 square nautical miles per hour.

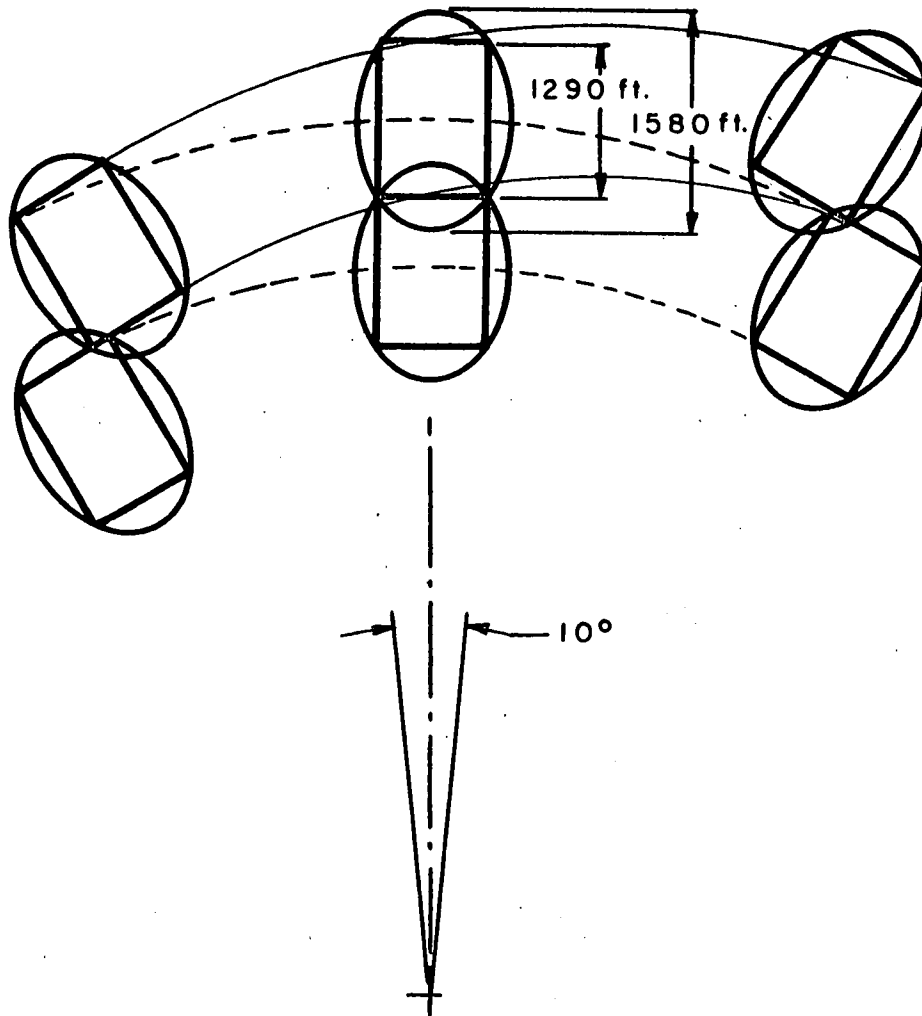

SCAN PATH

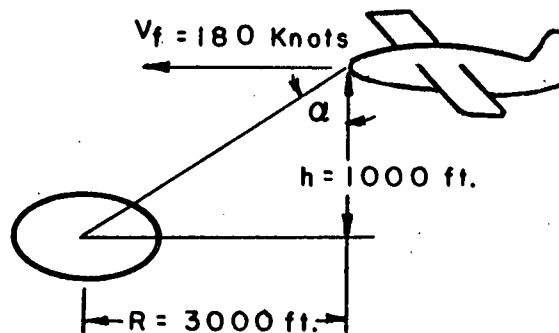

Figure 9. Illustration of the search geometry showing the area coverage on the surface of the ocean.

9.0 Lock-On Systems

The successful initial detection of the flyer in the water must be followed by an efficient method of steering to his location. With a rapid area search system such as that just described, the initial detection will be strong but the target will only be observed for a very short period of time unless the search pattern is disabled at the time of detection and a tracking operation initiated.

The television system recommended in this report is readily adapted to a tracking operation. The tracking phase would be initiated by the video pulse generated by a return from a retroreflective helmet. The first step would be to disable the azimuth sweep. Comparison of the temporal position of the signal relative to the horizontal and vertical sync pulses would yield polarity and magnitude of both vertical and azimuthal position errors. These error signals would be fed to the servo system which positions the field of view of camera and light source. The azimuth and elevation angles of the system would be displayed to the pilot in order that he can perform the proper maneuvers to bring him to a position where unaided vision allows him to observe the downed airman.

10.0 Summary and Conclusions

The pertinent findings of the study and the resulting recommendations may be listed as follows:

(a) Retroreflective Materials. It is recommended that the Navy investigate mounting methods for the Stimsonite experimental hexagon retroreflectors, from the standpoint of durability, ease of maintenance, and pilot safety. The tremendous potential performance gain achievable

with these buttons represents the most direct and immediate improvement to air-sea-rescue operations for both visual and photoelectric systems.

(b) Pulsed Light-Image Orthicon System. It is recommended that the Navy initiate a contract for the procurement of a prototype model of a pulsed light — image orthicon system. A reasonable set of specifications for such a system would be:

Operating Conditions

- (1) Atmospheric Transmission — 0.6/nautical mile
- (2) Helmet — 50% coverage with Stimsonite hexagonal buttons

System Performance

- (1) Detection Range — $\frac{1}{2}$ nautical mile, day and night
- (2) Area Coverage Rate — 180 square nautical miles/hour
- (3) Automatic Lock-On Capability

Such a system is within the present state of the art and should therefore be obtainable with a minimum of research and development time.

REFERENCES

- Blackwell, H. R., S. Q. Duntley, and W. M. Kincaid, "Characteristics of Tank-Mounted Searchlights for Detection of Ground Targets," Work Group on Tank Searchlight, Armed Forces-National Research Council Vision Committee, University of Michigan, 1953.
- Lane, Sr., J. W., T. H. Projector, W. A. Hall, and L. R. Noffsinger, "Evaluation Field Tests of Searchlight and Reflective Materials in Search and Rescue Operations," National Bureau of Standards Report 4606, April, 1956.
- Nathon, Alan M., "A Polarization Technique for Seeing Through Fogs with Active Optical Systems," Technical Report 362.01, New York University, June, 1957.
- "Descriptive Booklet Airborne Ranging Device Feasibility Test Unit," Engineering Report No. 245B, Farrand Optical Co., Inc., New York, June, 1954.