

IMPROVED

NOMOGRAPHS FOR CALCULATING

V I S I B I L I T Y B Y S W I M M E R S

(Natural Light)

S. Q. Duntley
1475 Virginina Way
La Jolla, California

February 1960

U. S. Navy, Bureau of Ships
Project S FO01 05 01

Contract NObs-72039, Task 5
Report No. 5-3

S U M M A R Y

This report provides nomographic charts for calculating the limiting range at which swimmers can sight underwater objects illuminated by natural light.

IMPROVED NOMOGRAPHS FOR
CALCULATING VISIBILITY BY SWIMMERS

Table of Contents

	Page
1. INTRODUCTION	1
2. SELECTION OF THE PROPER CHART	4
2.1 Introduction	4
2.2 Natural Illumination	4
2.3 Effect of Depth and Water Clarity	5
Stratified Water	5
Effect of Sea-state	6
Examples	7
2.4 Adaptation Level	7
Inclination Factor	8
Bottom Influence	8
2.5 Calculation of Adaptation Luminance	9
2.6 Chart Selection	10
3. USING THE NOMOGRAPHS	12
3.1 Introduction	12
3.2 Objects on the Bottom	12
Object Size and Shape	12
Vertical Path of Sight	12
Inclined Paths of Sight	16
3.3 The Secchi Disk	20
3.4 Target Markings	21
3.5 The Measurement of Target Reflectance	21
3.6 Horizontal Paths of Sight	23
3.7 The R_{∞} Correction	24

Table of Contents

	Page
3.8 Correction of the Sighting Range	25
4. INTERPRETATION OF SIGHTING RANGE	27
4.1 Introduction	27
4.2 Effect of Lack of Warning	28
4.3 Effect of Observer Training	28
4.4 Effect of Observer Visual Capability	29
5. VISUALIZATION OF WATER CLARITY	30
5.1 Introduction	30
5.2 Estimation of Sighting Range	30
5.3 Estimation of Adaptation Luminance	31
5.4 Estimation of α and K	32
5.5 Characterization of Natural Waters	32

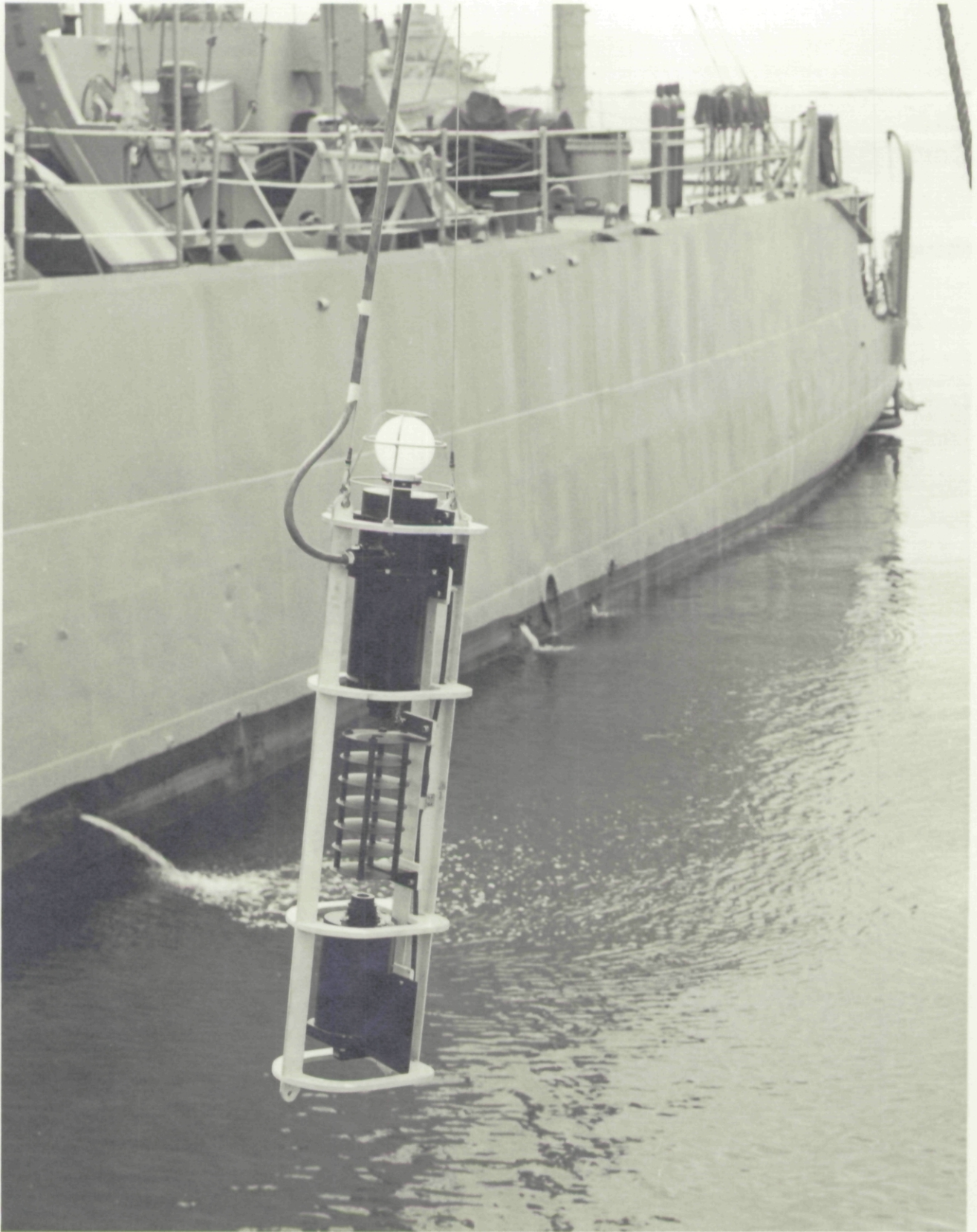



IMPROVED NOMOGRAPHS FOR
CALCULATING VISIBILITY BY SWIMMERS

I. INTRODUCTION

The water clarity meter shown in the frontispiece of this report is presently in use by the U. S. Navy Hydrographic Office. It was developed by the Visibility Laboratory of the Scripps Institution of Oceanography,¹ where equivalent instrumentation has been in use for several years. The measurement of water clarity is in terms of two attenuation coefficients, denoted by ∞ and K , which are the beam attenuation coefficient (∞) and the diffuse attenuation coefficient (K), respectively.

The limiting range at which a swimmer can sight any specified underwater object can be calculated from ∞ and K if sufficient information is available concerning the nature of the object, its lighting, its background, and the visual characteristics of the observer. Consider, for example, the two underwater photographs shown on the opposite page. In the upper picture the camera is looking steeply downward through twenty feet or more of water at a black-suited swimmer close to the bottom. At short range, as in the lower photograph, the swimmer's suit appears very black compared with the near-white bottom, but at twenty feet (upper picture) its

1. Austin, R. W., "Water Clarity Meter, Operating and Maintenance Instructions," Visibility Laboratory, University of California, SIO Ref. No. 59-9, February 1959.

apparent contrast is low; only the nearest fish and kelp leaves appear "black." At a slightly greater camera distance the swimmer would not be seen in the photograph because of insufficient apparent contrast. The greatest distance at which the swimmer can be seen by his companion, the photographer, may be calculated by means of the nomographic charts presented in this report.

The nomographic charts in this report can be applied to nearly every underwater viewing task if adequate input data concerning the object, its lighting and its background are available. In some instances, however, means for obtaining the necessary data are in an incomplete state of development. The applications discussed and illustrated in this report are visual tasks for which adequate input data are readily available.

The main body of this report is concerned with the prediction of sighting ranges along paths of sight which are inclined downward, and the nomographs are designed especially for this case. The visibility of flat, horizontal, non-glossy surfaces lying on the bottom or suspended far above the bottom can be calculated with great accuracy but three dimensional objects, particularly those with rounded surfaces, will be treated with slightly less certainty until additional development work, now in progress, has been completed. Sightings along upward-looking paths of sight are not treated in this report.

No discussion of the mathematical structure of the charts or of the underlying theory of hydrologic optics will be given, for these topics are to be the subject of a separate report. The present manual contains directions for the use of the nomographic visibility charts and presents illustrative numerical examples.

The nomographs contained in this report supercede the interim charts presented earlier.² The limitations inherent in the first edition have been removed.

². Duntley, S. Q., "Nomographs for Calculating Visibility by Swimmers, I. Natural Light," Contract NObs-72039, Report No. 3-1, May 1958.

2. SELECTION OF THE PROPER CHART

2.1 Introduction

The detection capabilities of any swimmer depend upon the level of light to which his eyes are adapted. This, in turn, depends upon the quantity of natural illumination on the surface of the sea, the depth of the swimmer, and the clarity of the water.

This report contains nomographic charts for nine adaptation conditions covering the entire range of light levels at which the human eye can operate, a range which extends from brightest day to darkest night. The first step in any visibility calculation is to ascertain the adaptation luminance to which the swimmer will be exposed and to select the appropriate chart.

2.2 Natural Illumination

The Bureau of Ships, U. S. Navy, has made a comprehensive study of natural illumination on the surface of the sea and has published an unclassified handbook-type report entitled "Natural Illumination Charts," (Project NS 714-100, Report No. 374-1, 1952) from which the illuminance in lumens per square foot (i.e., "footcandles") can be found for any location on earth at any time of day on any day in any year. A summary page from that report is reproduced as Figure 1; by means of this figure the illumination on the surface of the sea can be found if the altitude of the sun is known.

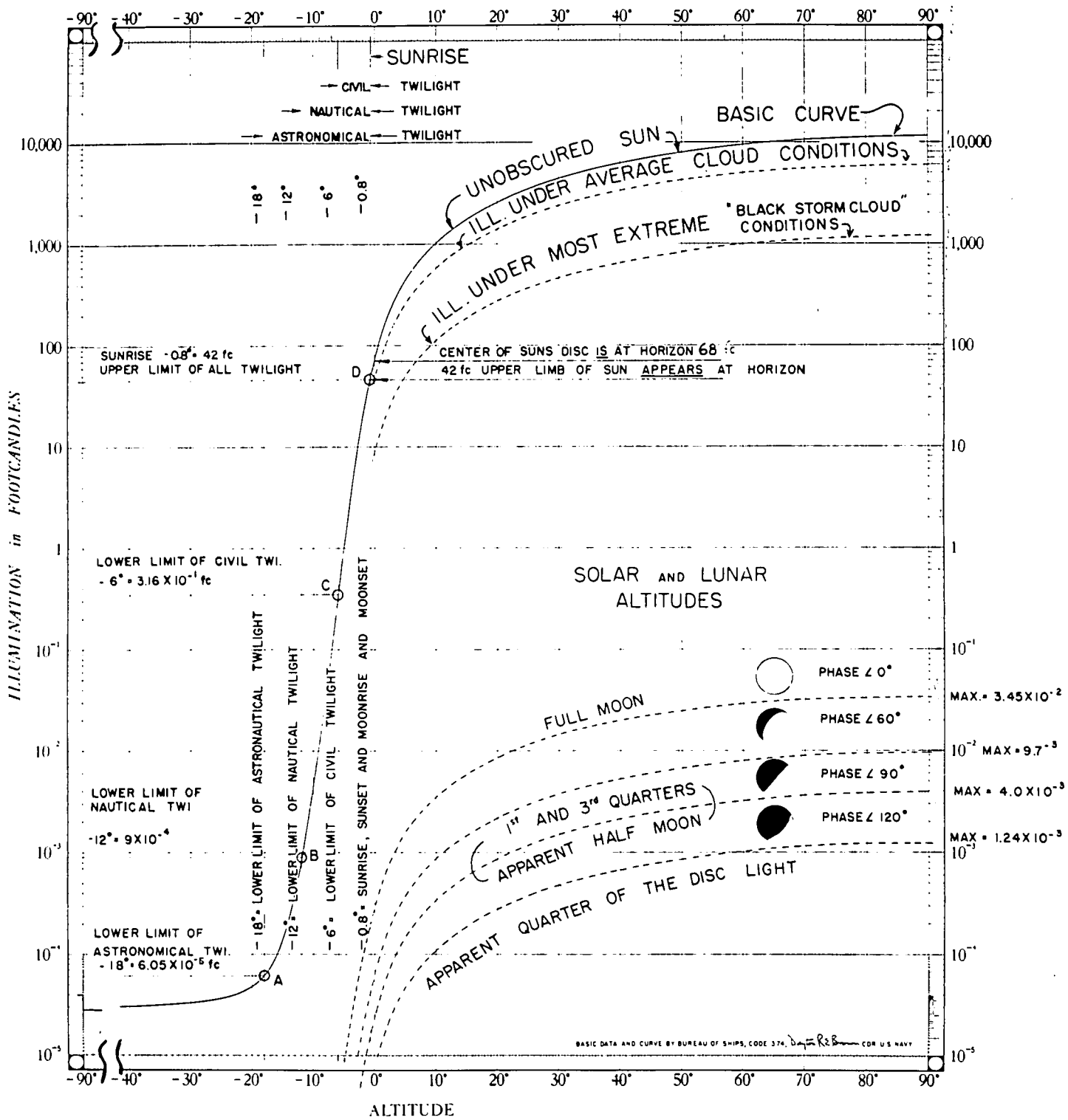

2.3 Effect of Depth and Water Clarity

If the illuminance on any fully exposed upward-facing horizontal surface is measured at various depths in any uniform stratum of sea water it will be found that, to a useful approximation, the illumination level decreases exponentially with depth, as illustrated by Figures 2 and 2A of this report. The slope of the straight line is measured by the diffuse attenuation coefficient K , which is defined by the equation

$$E_X = E_o e^{-KX}, \quad (1)$$

where E_o is the illuminance at the top of the uniform stratum, X is depth within the stratum, and E_X is the illuminance at depth X . Strictly, this equation relates to monochromatic light only, but it is a sufficient approximation to illuminance data for the practical purposes of this report.

If the measured value of K is the same from the sea surface to the target, X may be taken as the depth of the swimmer and the illuminance at his depth determined by multiplying the illuminance at the sea-surface (from Figure 1) by the appropriate factor read from Figure 2.

Stratified Water

If the water above the target is composed of two or more layers having different values of K , it will be necessary to use the

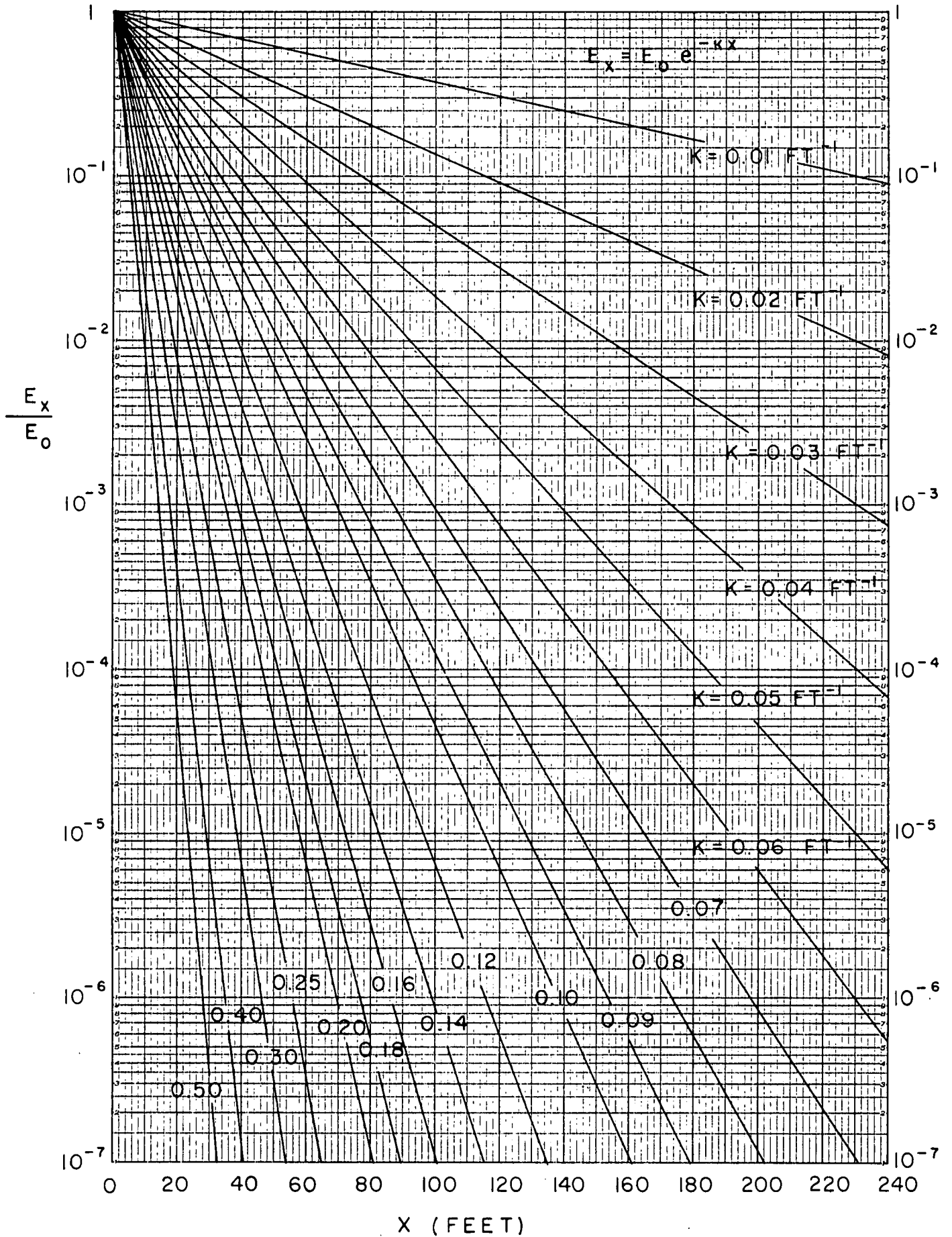
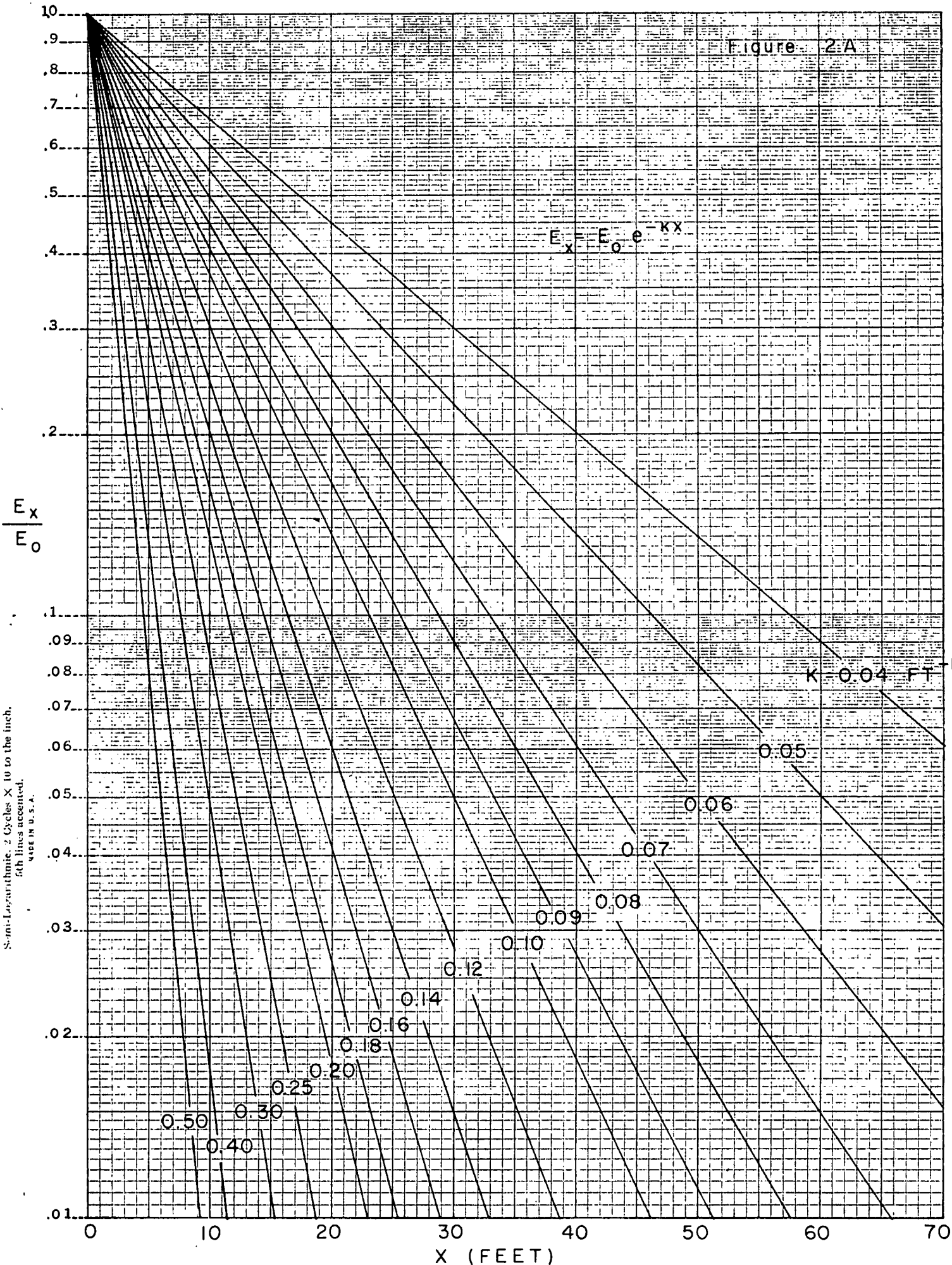

Figure 2



Semi-Logarithmic, 2 Cycles X 10 to the inch,
5th lines accented,
440614 U.S.A.

appropriate straight line in Figure 2 or 2A to obtain the factor for calculating the illuminance at the bottom of the first layer and use this value as the illumination incident on the top of the second layer, and so on until the level of the swimmer is reached. In other words, Figure 2 is used to determine factors for each successive layer, and the product of these factors is multiplied by the illuminance at the surface of the sea in order to obtain the illuminance at the depth of the swimmer.

The assumption of an average or weighted-average K for the entire distance from sea-surface to swimmer is often a sufficient approximation for the calculation of adaptation luminance and the subsequent selection of the proper nomographic chart. Even in extreme cases the use of a single K is often sufficient for this purpose.

Effect of Sea-state

Sea-state, i.e., wave conditions, have no significant effect on underwater lighting except near the surface, where small waves and ripples may cause the water to be filled with a rapidly moving ensemble of dancing beams of sunlight and where large waves may cause noticeable lighting fluctuations due to the effectively variable depth of the swimmer. When the sun is within 5-degrees of the horizon slightly more sunlight penetrates the water surface when it is rough than when it is calm, but the effect is ordinarily negligible in terms of visibility by swimmers.

Examples

On a certain cloudless sunny morning the illuminance at a point 40 feet beneath the surface in the entrance channel of a harbor was found by measurement to be 176 lumens/ft^2 and K at this depth was measured as 0.0943 per foot. A deck-cell showed the illuminance on the surface of the water to be 7600 lumens/ft^2 . Reference to Figure 2A or insertion of these numbers in equation (1) yields a predicted illuminance of 175 lumens/ft^2 , in excellent agreement with the measured value. A diver reported that no major clarity stratification was observable above 40 feet.

Half an hour earlier, however, the diver had reported a dense cloud of organic material between depths 10 and 15 feet. The surface illuminance at that time was 5200 lumens/ft^2 and K at 40 feet was 0.0943 per foot. The illuminance at 40 feet predicted from these numbers is 120 lumens/ft^2 , but measurement disclosed only 90 lumens/ft^2 . Obviously the cloudy stratum between 10 and 15 feet had lowered the illuminance at 40 feet by 30 lumens/ft^2 , and it would have been necessary to know K for this stratum in order to correct for its presence.

2.4 Adaptation Level

If the swimmer were just above a perfectly reflecting white bottom he would be adapted to a luminance level (expressed in foot-lamberts) numerically equal to the illuminance at his depth. If,

however, he is in water so deep that the bottom produces no influence on the light-field he will see, when looking straight down, a luminance numerically equal to approximately $1/50$ of the illuminance from above. Thus, if the illuminance on the top of the swimmer is 100 lumens/ft^2 he will observe an adaptation luminance of 2 foot-lamberts when looking straight down.

Inclination Factor

If the swimmer looks along an inclined path rather than straight down he will see an adaptation luminance which is greater by an amount known as the inclination factor. This factor depends upon depth and the downward direction in which he looks, as shown by the small graphs in the lower left corner of Figure 3. For example, if the swimmer is at a depth $9/K$ (i.e., 90 feet if $K = 0.1$ per foot) and looks downward in a direction having a zenith angle of 120 degrees in the azimuth of the sun he will observe approximately twice as much luminance as if his path of sight were straight down. In terms of the numerical example in the preceding paragraph, his adaptation luminance is $2 \times 2 = 4$ foot-lamberts.

Bottom Influence

If the swimmer is near the bottom, his adaptation may be affected, depending (1) on how greatly the bottom differs in reflectance from $1/50$, (2) on the clarity of the water, and (3)

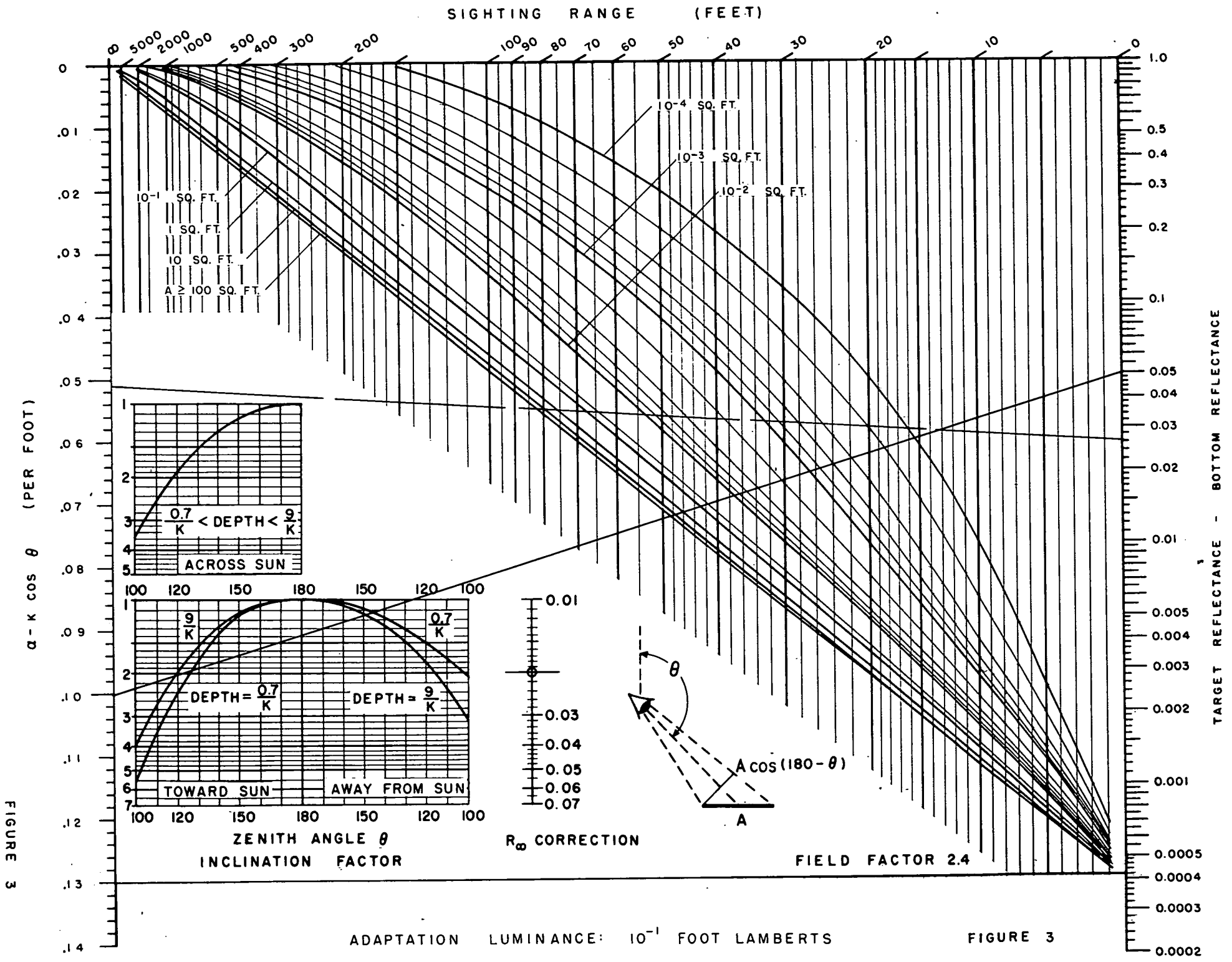

FIGURE 3

FIGURE 3

upon its distance from the swimmer. Generally speaking, dark mud bottoms have little or no effect on adaptation and light-colored bottoms have negligible influence when the sighting range is the order of $3/K$ or greater. Even at a sighting range of $1/K$ few bottoms are white enough to affect the swimmer's adaptation significantly. Generally speaking, therefore, the influence of the bottom upon adaptation can be neglected in calculating visibility by swimmers. It should be noted, however, that the reflectance of the bottom may have a major effect on the inherent contrast of the object and, therefore, upon its visibility, as discussed in Section 3.2 of this report.

2.5 Calculation of Adaptation Luminance

The foregoing discussion can be summarized and illustrated by concrete examples: Let it be required to find the adaptation luminance for a swimmer 60 feet beneath the surface of deep water characterized by a diffuse attenuation coefficient $K = 0.10$ per foot, a value typical of coastal water. Let it be assumed that the sun is 16.8 degrees above the horizontal plane.

Reference to Figure 1 shows that the illuminance on the sea-surface is 2000 lumens/ft^2 . Inspection of the line marked $K = 0.10$ per foot in Figure 2 shows that the horizontal plane containing the swimmer receives 2.5×10^{-3} as much downward light as does the sea-surface, or $2000 \times 2.5 \times 10^{-3} = 5 \text{ lumens/ft}^2$.

If the swimmer looks straight downward his adaptation luminance will be $5 \times 1/50 = 0.1$ foot lamberts if there is no bottom influence.

If the swimmer looks along a downward slant path having a zenith angle of 110 degrees in a plane at right angles to the azimuth of the sun, the inclination factor graph in Figure 3 shows that his adaptation luminance is 2.5 times greater than if he looks straight down. Along this inclined path of sight the swimmer's adaptation luminance is, therefore, $0.10 \times 2.5 = 0.25$ foot lamberts. The user of Figure 3 should verify that the "across sun" curve is applicable by noting that the depth (60 feet) of the swimmer is $6/K$, since $K = 0.10$ per foot, and that this depth lies between limits specified in the figure.

Had the solar elevation been 65 degrees, Figure 1 shows that the illumination at the sea-surface would have been $10,000 \text{ lumens/ft}^2$ and the adaptation luminances of the swimmer at 60 feet would, therefore, have been five times higher; i.e., 0.50 foot-lamberts when looking straight down and 1.25 foot-lamberts when looking at right angles to the azimuth of the sun along a downward path of sight having a zenith angle of 110 degrees.

2.6 Chart Selection

This report contains nine pairs of nomographic charts, each pair representing a decimal value of adaptation luminance, as follows: 1000, 100, 10, 1, 10^{-1} , 10^{-2} , 10^{-3} , 10^{-4} , 10^{-5} foot-lamberts.

After the adaptation luminance of the swimmer has been calculated the chart closest to this level is selected. If the adaptation luminance is not close to any decimal value, sighting range for the visual target should be calculated by means of charts for higher and lower light levels respectively in order to bracket the desired answer and provide for interpolation between these sighting ranges.

3. USING THE NOMOGRAPHS

3.1 Introduction

Once the adaptation luminance for the swimmer has been determined and the proper nomographic chart selected, sighting ranges can be predicted. The calculation procedures are slightly different for each type of visual task and, therefore, they will be discussed separately.

3.2 Objects on the Bottom

The nomographic visibility charts in this report can be used to calculate the sighting range of flat, horizontal objects of uniform reflectance lying on the bottom.

Object Size and Shape

The size of the object is measured by its area, expressed in square feet; the shape of the object is unimportant unless it is an extremely elongated form (10:1 or greater) and unless adaptation luminance is 10 foot-lamberts or greater. Even in such unusual cases the effect of object shape on sighting range is usually small.

Vertical Path of Sight

Sighting range calculations are simplest when the path of sight is vertically downward. The nomograph requires five items of input data: target area, target reflectance, bottom reflectance, the

beam attenuation coefficient μ , and the diffuse attenuation coefficient K . The coefficients μ and K must be for the water between the swimmer and the target.

The vertical scale on the nomograph is labeled $\mu - K \cos \theta$. A downward vertical path of sight has a zenith angle $\theta = 180$ degrees, and $\cos 180 = -1$. A point representing the sum of μ and K , expressed in reciprocal feet, is marked on the left vertical scale.

The right vertical scale is labeled "target reflectance minus bottom reflectance." The algebraic sign of this difference is of no importance; if the bottom is more reflective than the target the difference will, of course, be a negative number; disregard the negative sign and plot the magnitude of the difference on the right vertical scale. Reflectance must be expressed as a decimal; i.e., as 0.06, not as six percent. Bottom reflectance should be measured at the sea-bottom with great care to avoid disturbing any fine silt which may be present. Bottom samples cannot be brought to the surface for measurement without disturbing the material sufficiently to alter its reflectance. Target reflectance may be measured at the sea-bottom or on ship-board by means of a technique described in Section 3.5 of this report.

The curved lines which cover the upper right corner of the nomographic visibility charts represent visual threshold data for the target area with which each curve is identified. (The refractive effect of the swimmer's flat face-plate has been allowed for in

constructing these nomographs.) Curves representing decimal values of target area are marked accordingly. Intermediate unmarked curves refer respectively to 2, 4, 6, and 8 times the decimal value except in those cases when only a single line appears between decimal curves; in this case the unmarked curve related to 5 times the decimal value.

Special Charts for Water of Low-clarity. Two series of nine nomographic charts are presented in this report: In the first series, the scales have been optimized for use in clear oceanic and coastal waters where sighting ranges of 20 feet to 100 feet or more often occur. The second series of charts are designed for waters of poor to medium clarity where sighting ranges of 1 foot to 20 feet or more prevail. Either series of charts may be used for any problem having input data within the range of its scales, but experience will quickly indicate which chart is best suited for any given problem.

Sighting Range Calculations, Clear Water. To calculate sighting range, connect the appropriate points on the left and right vertical scales by a straight line and note its intersection with the curve corresponding to the area of the target. From this intersection proceed vertically to the sighting range scale. The following numerical example will illustrate this procedure with the aid of Figure 3.

Let the following input data be assumed:

adaptation luminance = 10^{-1} foot-lamberts
 target: flat; horizontal; on the bottom
 target area = 10 square feet
 target reflectance = 0.080; non-glossy
 bottom reflectance = 0.030
 beam attenuation coefficient = ∞ = 0.073 per foot
 diffuse attenuation coefficient = K = 0.027 per foot

From these data, $\infty + K = 0.100$ and target reflectance minus bottom reflectance = 0.050. The solid line drawn on Figure 3 intersects the curve marked "10 square feet" at the vertical line denoting a sighting range of 47.6 feet. The same line drawn on Figure 3 indicates that a swimmer looking straight down under the assumed conditions can sight a 0.1 square foot object at 43 feet, an object of 1 square foot at 46 feet, and all objects of area 100 square feet or more when he is 48.5 feet or less from the bottom.

Sighting Range Calculations, Low-clarity Water. The same example may be solved by means of the low-clarity chart (Figure 4) and corresponding sighting ranges obtained, but with far less precision.

Readers possessing the earlier edition of the nomographs² will find those charts incapable of solving this example for target areas greater than 1 square foot; it will also be discovered that the sighting range cannot easily be read with precision.

In an hypothetical water of lesser clarity, characterized by $\infty = 0.43$ per foot and $K = 0.17$ per foot, the sum $\infty + K = 0.60$. If all other input data remain unchanged the high-clarity nomograph

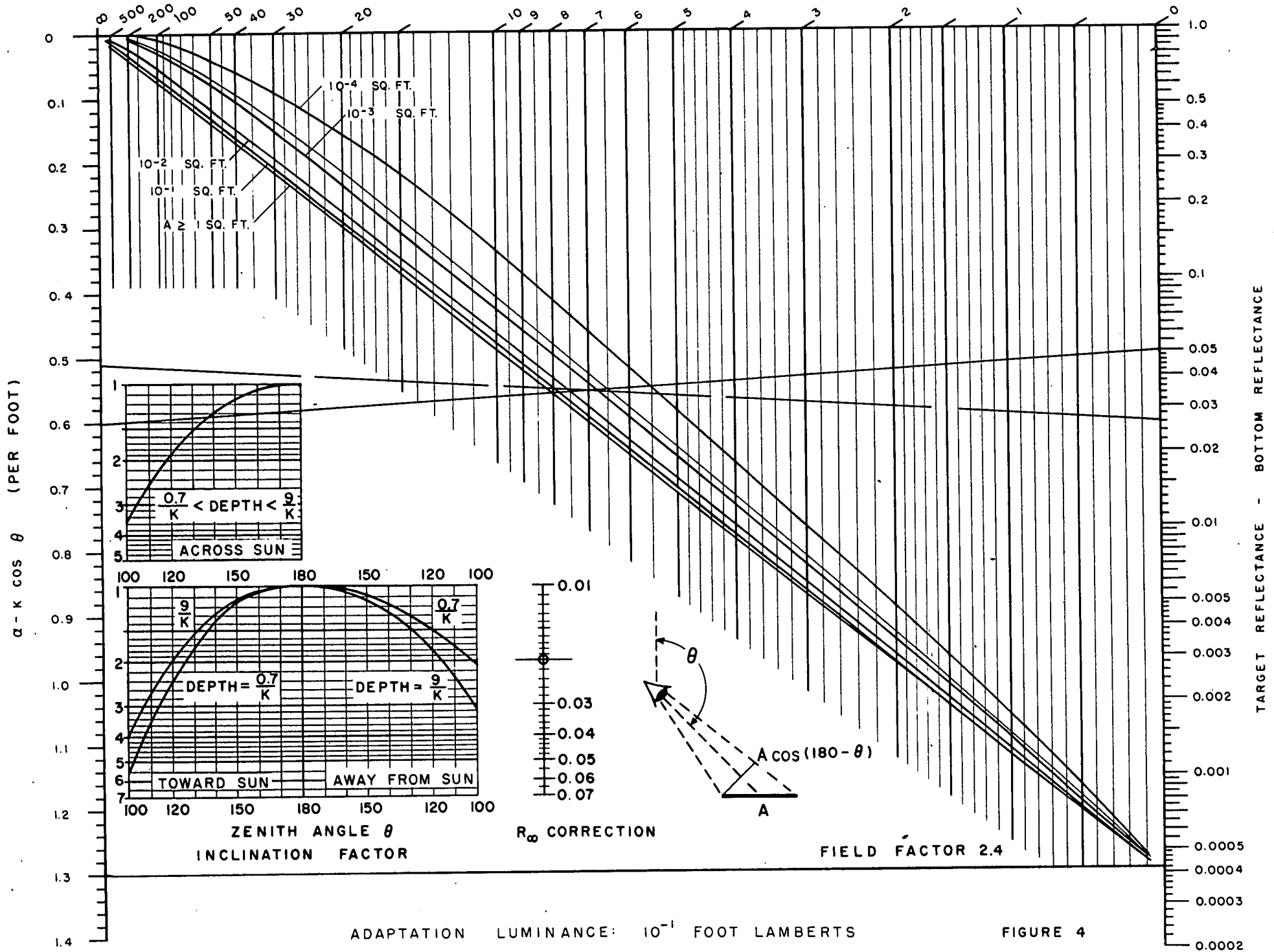

FIGURE 4

ADAPTATION LUMINANCE: 10^{-1} FOOT LAMBERTS

FIGURE 4

(Figure 3) cannot readily be used because its left vertical scale goes only to 0.14. Actually, this chart can be adapted by extending the left vertical scale linearly downward to 0.60 and constructing a diagonal line from that point to 0.05 on the right vertical scale, but such a procedure is unnecessary because the low-clarity nomograph (Figure 4) is available. The straight line drawn on that figure indicates by its intersection with the lower-most curve that flat horizontal objects of all sizes greater than 1 square foot can be seen by a swimmer looking straight down under the assumed conditions when he is 8 feet or less from the bottom. The same line shows by other intersections, that he must descend to within 7.5 feet of the bottom to see an object 10^{-2} square feet in area and to 5.5 feet from the bottom before a tiny object of area 10^{-4} square feet can be seen.

Inclined Paths of Sight

The nomographic visibility charts can be used for the calculation of sighting range along inclined paths of sight. Three additional items of input data are necessary: (1) the approximate azimuth of the path of sight relative to the sun, (2) the depth of the swimmer expressed in units of $1/K$, and (3) the zenith angle of the path of sight.

The first two items of data are used to estimate the increase in adaptation luminance associated with the inclined path. This is accomplished by means of the inclination factor curves in the lower left corner of Figure 3. (Identical curves appear on all of the

nomographic visibility charts.) A continuation of the numerical example begun in the preceding section will illustrate this step:

Let the following input information be assumed:

(1) Azimuth of the path of sight: at right angles to the azimuth of the sun; i.e., the path of sight is "across sun."

(2) Depth of swimmer = 2.7/K. This would be the case if his depth is 100 feet and $K = 0.027$. The depth, $2.7/K$, falls within the range for which the "across sun" curve applies.

(3) Zenith angle of the path of sight = 120 degrees.

Effect of Zenith Angle on Adaptation. Reference to the "across sun" inclination factor graph discloses that the inclination factor for this zenith angle is 1.9. This means that the adaptation luminance is 1.9 times as great as that experienced by the swimmer when looking vertically downward; i.e., $1.9 \times 10^{-1} = 0.19$ foot-lamberts. Since this adaptation luminance falls between the nomograms for 1 and 10^{-1} foot-lamberts, both charts should be used in order to bracket the sighting range. The effect of adaptation on sighting range will be discussed further in a later part of this section and illustrated by Figure 5.

Effect of Zenith Angle on Left Vertical Scale. The zenith angle of the path of sight (120 degrees) affects the value plotted on the left vertical scale of the nomograph:

$$\infty - K \cos \theta = 0.43 - (0.17)(-0.50) = 0.51.$$

A table of cosines is included as an appendix at the end of this report.

Effect of Zenith Angle on Effective Area. Zenith angle also affects the effective area of the object; thus

$A \cos (180 - \theta) = 10 \times 0.50 = 5$ square feet. Inspection of the curves in Figure 4 shows that, in this case, no sighting range will be lost by the foreshortening because all targets having an effective area greater than 1 square foot are visually detectable at the same distance under the conditions assumed in this numerical example. A table of $\cos (180 - \theta)$ is included as an appendix at the end of this report.

Effect of Inclination Factor on Right Vertical Scale. The inclination factor affects the value plotted on the right vertical scale as follows: The difference between target reflectance and bottom reflectance must be divided by the inclination factor before the number is plotted. Thus, $0.050 \div 1.9 = 0.026$. The inclination factor curves which appear on each chart have been plotted on an inverted logarithmic scale having the same modulus as the right vertical scale of the nomograph in order that the division can be accomplished graphically. Draftsman's dividers can conveniently be used for this purpose: measure downward from the top border of the figure to the inclination factor curve and transfer this setting to the right vertical scale of the nomograph, using it to reduce the plotted value of target reflectance minus bottom reflectance.

Calculation of the Sighting Range. The broken line on Figure 4 shows that the sighting range would be 8.1 feet for the inclined path if the adaptation luminance was 10^{-1} foot-lamberts. Since, as shown

above, the adaptation luminance is 1.9×10^{-1} foot-lamberts a minor correction to the sighting range should be made in the following manner:

Effect of Adaptation on Sighting Range. Since the luminance to which the swimmer's eyes are adapted is 0.19 foot-lamberts, an interpolation should be made between the sighting range 9.1 feet indicated by the nomograph for 1 foot-lambert and the sighting range 8.2 feet indicated by the nomograph for 10^{-1} foot-lambert. By linear arithmetic interpolation, $8.2 + (9.1 - 8.2)(1.9 \times 10^{-1}/10.0 \times 10^{-1}) = 8.4$ feet. This value compares with the sighting range of 8.5 feet found by the graphical interpolation provided by Figure 5, which illustrates the effect of adaptation on sighting range in this illustrative example. Figure 5 has been prepared by assuming successively all decimal values of adaptation luminance and plotting the resulting sighting ranges given by the entire series of nomographic charts.*

Linear arithmetic interpolation of sighting range between adjacent decimal levels of adaptation luminance suffices for the needs of most problems.

* The discontinuity in curve slope at about 4.4×10^{-4} foot-lamberts results from a change from central fixation to averted vision on the part of the swimmer, in order to achieve maximum sighting range in the dim light; this change of fixation is built into the nomographs.

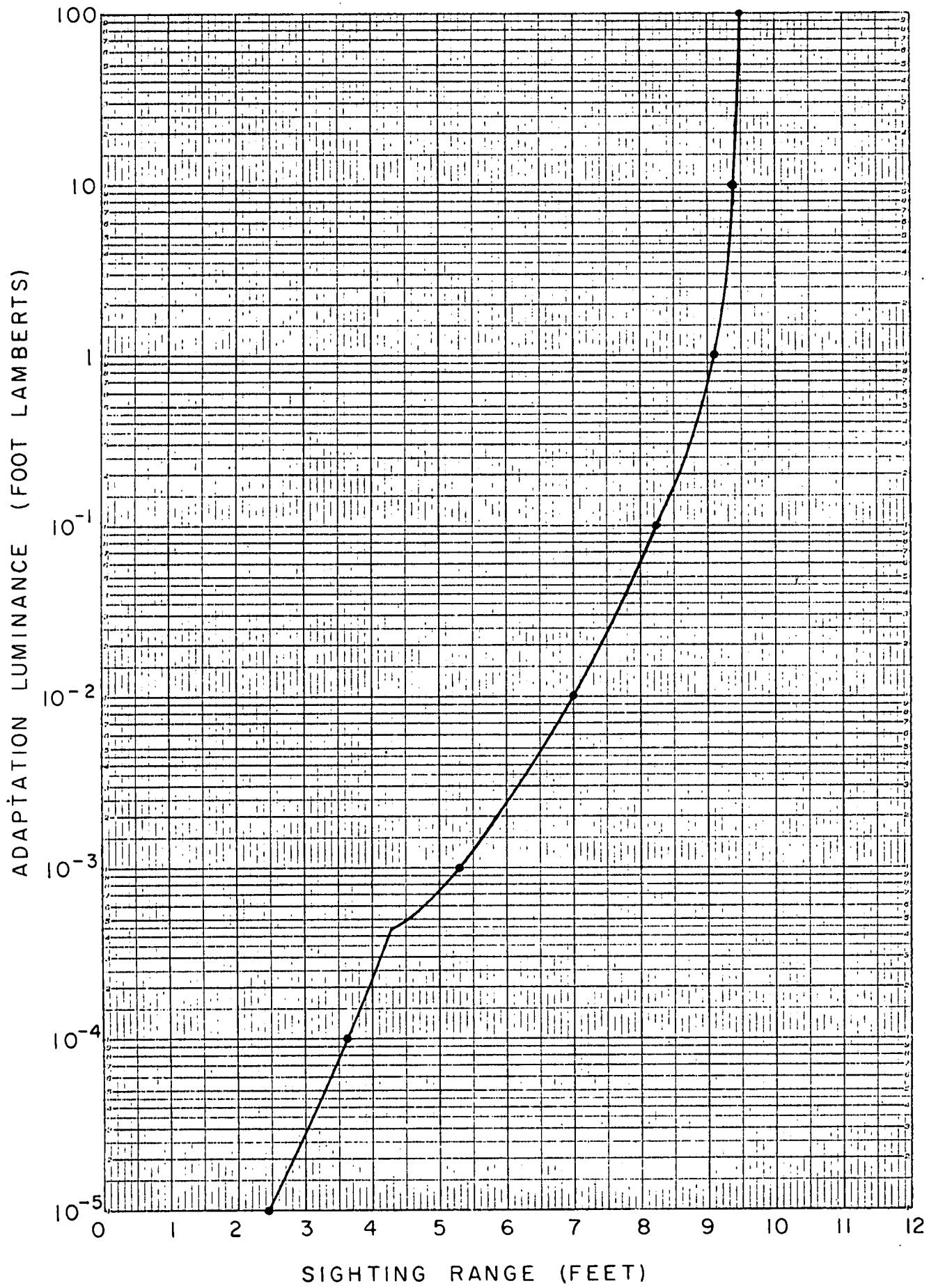

Figure 5

Implication of the Sighting Range. Although the sighting range for the inclined path (8.5 feet) happens to be only slightly longer than the sighting range for the vertical case, it should be recognized that the swimmer must be within 4.25 feet of the bottom in order to see the target at this inclination angle.

3.3 The Secchi Disk

The underwater sighting range of a flat horizontal surface of uniform reflectance, suspended in (optically) deep water, e.g., a Secchi Disk, can be calculated by means of the nomographic visibility charts. Ordinarily, Secchi Disk readings are obtained by an observer above the surface of the sea who must look downward through the surface. Sky reflection and complex refractive effects resulting from water waves greatly complicate the interpretation of the greatest depth at which the disk can be seen. If, however, a swimmer lowers a Secchi Disk beneath him and observes its disappearance, the sighting range can be predicted by means of the nomographic visibility charts if ∞ and K are known. Conversely, the observed sighting range can be inserted in the nomograph in order to find the sum of the attenuation coefficients, $\infty + K$.

Let it be assumed that the water is so deep beneath the disk that the bottom has no significant effect upon the light field. The nomographs are so constructed that they will correctly predict the sighting range of the disk if the right vertical scale of the nomograph is imagined to be labeled "Secchi Disk reflectance minus 0.02."

All other details of the calculation are identical with those described in the preceding sections of this report which deal with objects on the sea-bottom. Attention is called, however, to subject matter of Section 3.7, entitled "The R_{∞} Correction."

3.4 Target Markings

The preceding sections of this report have dealt with the sighting range of the whole target. It is sometimes important to calculate the sighting ranges of certain details or markings on a target. This is readily accomplished by means of the nomographic visibility charts. The only modifications of the procedure described in the preceding sections are (1) to imagine the right vertical scale to be labeled "reflectance of marking - reflectance of target," and (2) to use the curve which applies to the area of the marking.

3.5 The Measurement of Target Reflectance

The reflectance of painted surfaces differ, often markedly, when dry and when wet. The values of target reflectance required for use in the nomographic visibility charts are those which would be measured by a water-filled reflectometer submerged with the target. This submerged reflectance differs from reflectances measured by conventional laboratory reflectometers even if the painted surface is wet.

Target reflectance may be measured at the sea-bottom, or, with greater convenience, it may be measured on ship-board by means of a technique developed by the Visibility Laboratory and described on

pages 27, 28, and 29 of a report entitled "The Visibility of Submerged Objects" (the combined final report of contracts N5 ori-07831, NS ori-07864, and NObs-50378) dated 31 August 1952. Exerpts from that report have been assembled and are reproduced on the following page for the convenience of the reader:

Reflectance measurements with special water-filled equipment are not necessary. A technique has been evolved for measuring R_o with any conventional reflectometer which irradiates the sample at 45-degrees and views it normally. This technique involves wetting the sample and measuring it while the surface is covered by a thin film of water.

$$R_o = \frac{w}{0.420w + 0.564} \quad (2.43)$$

A plot of Eq. (2.43) is shown by the solid line in Fig.16 . Close agreement between measured values of R_o , shown by the plotted points, and the predictions of Eq. (2.43) was found, even for samples of moderate gloss.

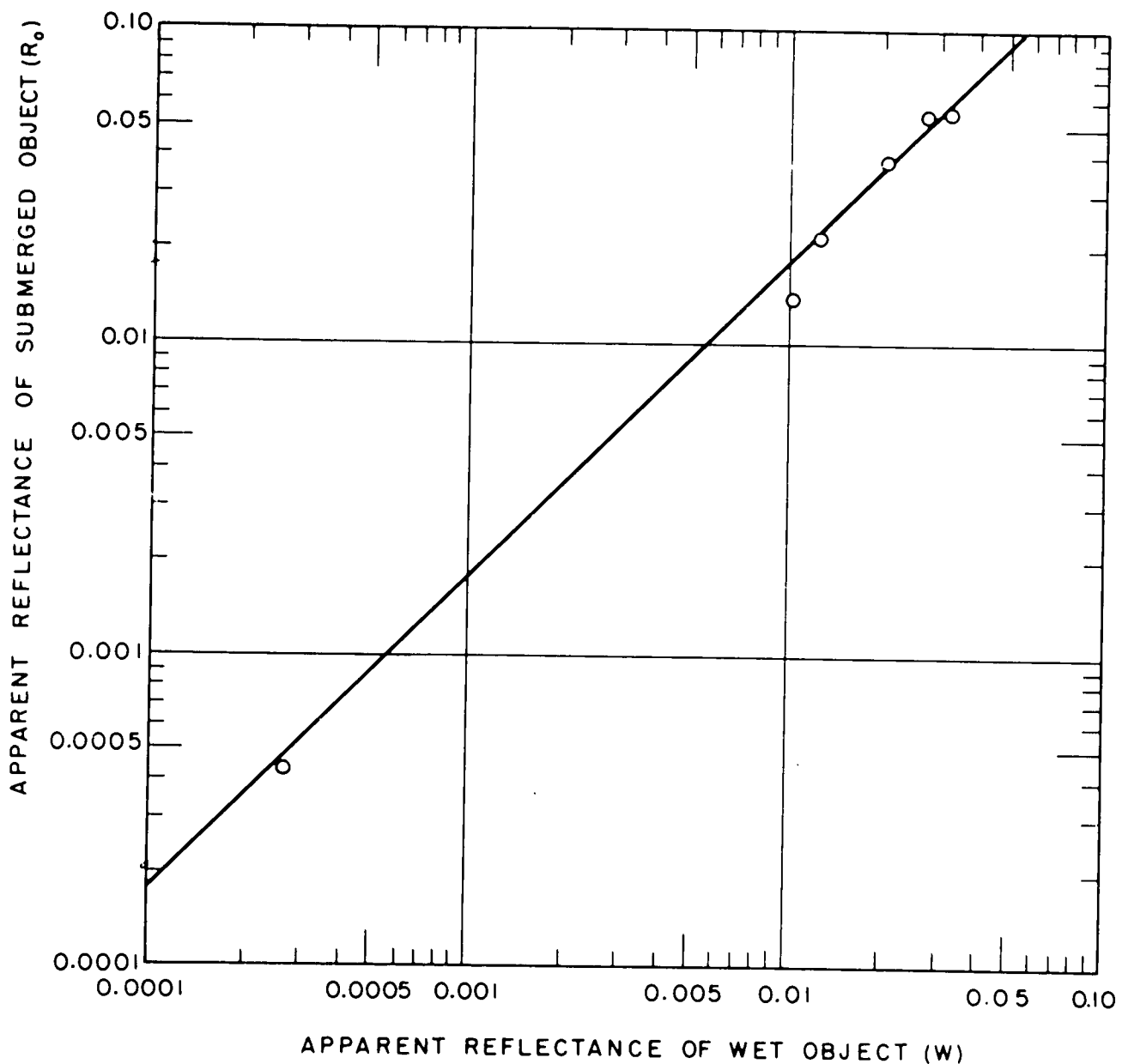

Figure 16

3.6 Horizontal Paths of Sight

The visibility nomographs can be used for calculating sighting ranges along horizontal paths of sight provided the inherent contrast of the object against its horizontal water background is known. No means for ascertaining this inherent contrast information is provided by this report; it can be pointed out, however, that any dark object seen as a silhouette has an inherent contrast of approximately -1.

For the calculation of horizontal sighting ranges, the right vertical scale should be imagined to be labeled "inherent contrast + 50." Thus, an inherent contrast of ± 1 plots at the point marked 0.02 on the right vertical scale.

For horizontal paths of sight the zenith angle $\theta = 90$ degrees and, since $\cos 90 = 0$, the left vertical scale involves the beam attenuation coefficient ∞ only. The areas associated with the curved lines on the nomograph refer to the projected area of the target as seen from the position of the swimmer.

Sighting ranges are calculated by connecting the right and left vertical scales with a straight line, and reading the sighting range from the scale division directly above the intersection of this line with the curve which applies to the target area. When the nomographic charts are used in this manner for horizontal sighting range calculations no approximations are involved so that neither of the corrections described in the next two sections of this report are required.

3.7 The R_{∞} Correction

In nearly all optically deep natural waters and at all depths approximately 50 times more illuminance reaches any horizontal plane from above than from below. The ratio of the illuminance from below to the illuminance from above is denoted by the symbol R_{∞} . This notation implies that the (optically) infinite deep water beneath any horizontal plane in the sea could be replaced, for optical purposes, by a surface of reflectance R_{∞} . This quantity is often measured by means of two photoelectric cells mounted back-to-back and facing upward and downward respectively.

Because $R_{\infty} = 0.02$ for most natural waters of moderate to high clarity, the nomographic visibility charts have this value built into their scales. If R_{∞} is known to be different than 0.02 in any specific instance, this information can be entered in the calculation by dividing the value of "target reflectance-bottom reflectance" by $50 R_{\infty}$ before plotting the point on the right vertical scale of the nomograph. Alternatively, the " R_{∞} CORRECTION" scale printed on the nomograph can be used to apply a correction after the point has been plotted but before the line is drawn across the chart. Draftsman's dividers are a convenient tool for this purpose: Set one leg of the dividers at the circled point on the " R_{∞} CORRECTION" scale and adjust the other leg to the known value of R_{∞} . Transfer this setting to the right vertical scale, maintaining the direction of the correction indicated by the " R_{∞} CORRECTION" scale; i.e., the plotted point on the right vertical scale is moved downward when R_{∞} exceeds 0.02, and upward when R_{∞} is less than 0.02.

3.8 Correction of the Sighting Range

The nomographic visibility charts involve certain algebraic approximations which may lead to invalid sighting ranges when the indicated value of sighting range is short and when the reflectance of the bottom departs markedly from 0.020. Figure 6 is provided as a means for testing any indicated sighting range for error and indicating the needed correction. The following numerical example will illustrate the use of Figure 6.

A sighting range of 4 feet is indicated by the nomographic visibility chart when:

adaptation luminance 10^{-1} foot-lamberts
 target area = 10^{-3} square feet
 $\infty - K \cos \theta = 0.50$
 bottom reflectance = 0.10
 inclination factor = 2
 target reflectance - bottom reflectance = 0.010

Since the sighting range is short and the reflectance of the bottom departs markedly from 0.020, the predicted sighting range should be tested and corrected by means of Figure 6, as follows:

On the vertical scale of Figure 6, labeled "sighting range x ($\infty - K \cos \theta$)" enter the data $4 \times 0.5 = 2$. On the horizontal scale labeled "bottom reflectance/inclination factor" enter the data $0.10/2 = 0.05$. These entries locate a point on Figure 4 which falls close to the curve marked 0.83. This factor is to be applied to the value of "target reflectance - bottom reflectance." Thus, $0.010 \times 0.83 = 0.0083$. If this corrected value is plotted on the right

Figure 6

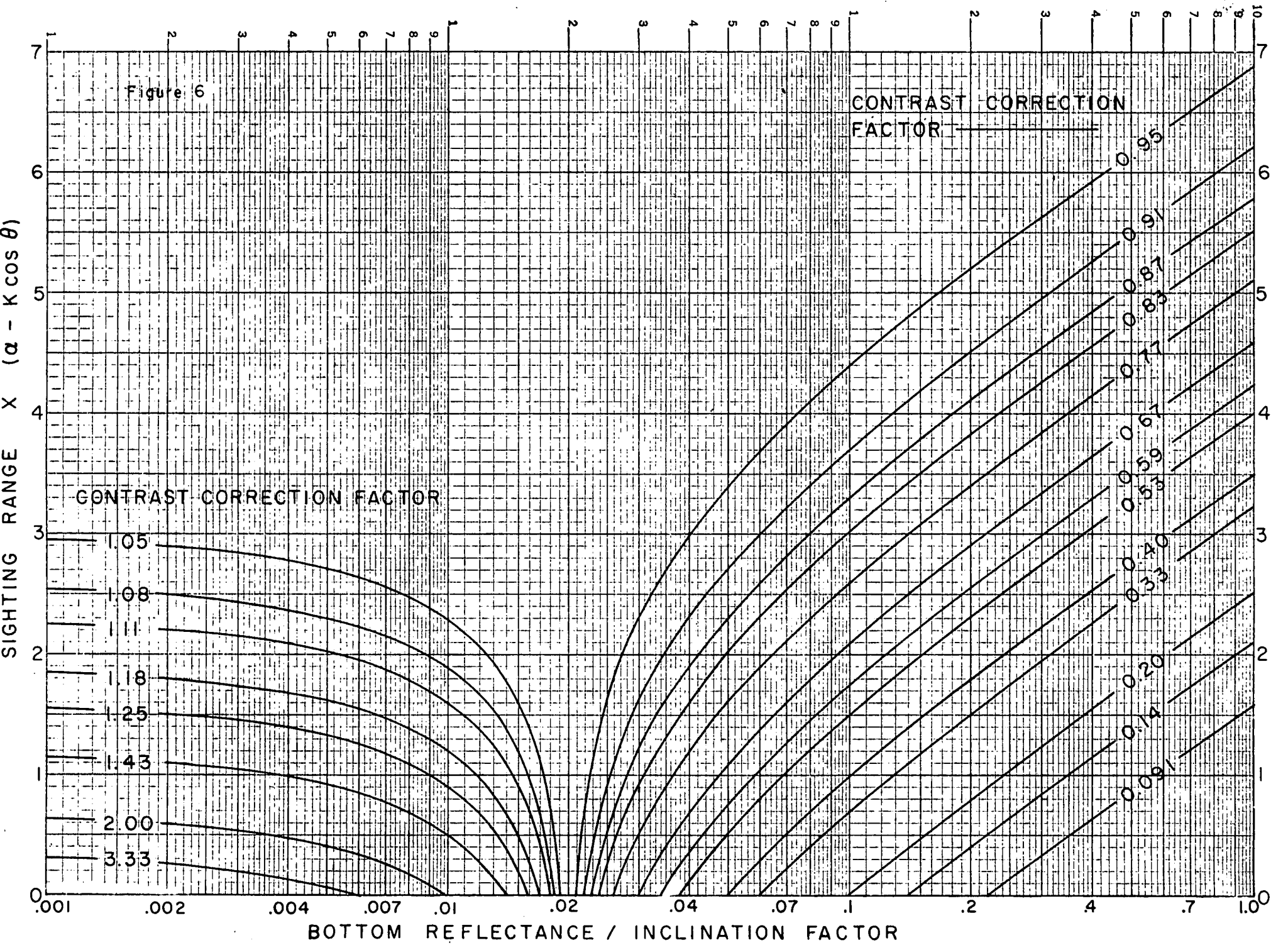

vertical scale on the nomographic visibility chart the corrected sighting range is 3.72 feet.

Except in extreme cases the corrected sighting range will differ but little from the uncorrected value. In most cases the point on Figure 6 will plot above the highest curve, indicating thereby that no correction is required.

Like the nomographic visibility charts, Figure 6 has been constructed with the assumption that $R_{\infty} = 0.020$. If R_{∞} is known to differ from this value this information can easily be inserted in the correction process by dividing the value of "bottom reflectance/inclination factor" by $50 \times R_{\infty}$ before plotting the point on Figure 4. Thus, in the foregoing example if $R_{\infty} = 0.0154$, the horizontal coordinate of the point on Figure 4 is $0.050 / (50 \times 0.0154) = 0.065$, and the correction factor is 0.77 rather than the value 0.83 obtained before the insertion of the R_{∞} information, and the new corrected sighting range is 3.60 feet.

4. INTERPRETATION OF SIGHTING RANGE

4.1 Introduction

The sighting ranges calculated by means of the nomographic visibility charts are the limiting distances at which a swimmer will be aware of seeing the object. It is assumed that he is fully familiar with the underwater environment, well acquainted with the objects for which he looks, and possessed of perfect vision. It is not assumed, however, that his training has included a lengthy special training period devoted to maximizing his ability to produce long sighting ranges.

It is assumed that the swimmer knows the direction in which to look and that he expects to see the visual target. In other words, the swimmer is not required to search his visual field and there is no problem of vigilance.

The above described interpretation of "sighting range" is indicated on the nomographic visibility charts by the inscription "field factor 2.4." This notation, meaningful only to specialists in visibility calculations, implies that nomographic charts can be constructed to depict other levels of observer performance, i.e., other values of "field factor." A general discussion of visual search, field factors, and observer characteristics will not be attempted in this report, but three common effects will be discussed in simplified form in the following paragraphs.

95% Probability

4.2 Effect of Lack of Warning

When an underwater object is encountered by a swimmer without warning, the sighting range will be somewhat shorter than otherwise. This is to say that unexpected objects will be less well detected initially than will those whose existence is known and whose appearance is expected. This effect is independent of training, experience, or visual capability. Its effect upon the sighting range can be allowed for by dividing the value of "target reflectance minus bottom reflectance" by 1.2 before entering the right vertical scale of the nomographic charts.

4.3 Effect of Observer Training

Extensive practice in sighting underwater targets at limiting distances will enable good observers to exceed slightly the normal sighting range. A correction for the effect of training can be made by multiplying the value of "target reflectance - bottom reflectance" by a training factor between 1 and 2 before entering the right vertical scale of the nomographic charts. A training factor of 1.0 represents the usual capability of experienced swimmers who are fully familiar with the underwater environment and are well acquainted with the object for which they look; this value (unity) should ordinarily be used. If an experienced swimmer is considered to be unusually good at underwater sightings a training factor of 1.2 is recommended.*

* It will be recognized that the factor 1/1.2 for lack of warning and the training factor 1.2 cancel; thus the nomographic charts as drawn apply without correction to the case of the experienced, highly trained swimmer who comes upon objects without warning.

Laboratory experience indicates that only after many thousands of careful attempts to achieve sightings at maximum range can even the most experienced personnel achieve a training factor of 2.

4.4 Effect of Observer Visual Capability

All human eyes are not created equal with respect to their capability to detect underwater objects at limiting range; this is not a matter of training but represents subtle physiological differences between men which are beyond detection by ordinary eye-examinations. The nomographic charts have been drawn to represent the performance of average "perfect" young eyes. Some estimate of the affect on sighting range of the spread in visual capability within the population of "perfect" observers can be obtained by successively doubling and halving the value of "target reflectance minus bottom reflectance" before entering the right vertical scale of the nomographic chart.

5. VISUALIZATION OF WATER CLARITY

5.1 Introduction

The clarity of natural waters can be visualized directly in terms of the attenuation coefficients α and K on the basis of experience gained through the use of the nomographic visibility charts. It will be found that most objects can be sighted at 4 to 5 times the distance $1/(\alpha - K \cos \theta)$ unless the adaptation level is low; exceptions to this rough rule-of-thumb are common but they can easily be categorized. Alternatively, a convenient conceptualization of the appearance of any underwater environment can be obtained from $1/\alpha$ and $1/K$.

5.2 Estimation of Sighting Range

The rough rule-of-thumb stated in the preceding paragraph is illustrated by the examples in Section 3.2 of this report. In the first (clear water) case $1/(\alpha - K \cos \theta) = 1/0.10 = 10$ feet and the vertical sighting range of the large (10 square feet) object is 48 feet, or 4.8 times $1/(\alpha - K \cos \theta)$. In the second (low-clarity water) case $1/(\alpha - K \cos \theta) = 1/0.60 = 1.67$ feet and the vertical sighting range of the same target is 8.0 feet, or 4.8 times $1/(\alpha - K \cos \theta)$.

The value 4.8 is not universal; it will be altered by changing target size, adaptation luminance, zenith angle, target reflectance, etc. For example, it was noted in Section 3.2 that in the low-clarity water the vertical sighting range of a small target 10^{-2} square feet in area is 5.5 feet or 3.3 times $1/(\alpha - K \cos \theta)$.

If, however, the reflectance of the original 10 square foot visual target had been 0.330 (instead of the value 0.080 assumed in Section 3.2), thus forming a high inherent contrast with the dark (0.030) bottom, its vertical sighting range is found to be 11.0 feet or 6.6 times $1/(\alpha - K \cos \theta)$. In summary, small values of target size or low values of adaptation luminance (or both) will produce sighting ranges shorter than 4 times $1/(\alpha - K \cos \theta)$ whereas high values of "target reflectance minus bottom reflectance" make large objects visually detectable at ranges in excess of 5 times $1/(\alpha - K \cos \theta)$.

An important and common special case is that of large dark objects viewed horizontally. In this case $1/(\alpha - K \cos \theta) = 1/\alpha$, since $\cos 90^\circ = 0$, and the sighting range will be approximately 4 times $1/\alpha$ unless the adaptation luminance is low.

5.3 Estimation of Adaptation Luminance.

Inspection of Figure 1 of this report will enable convenient order-of-magnitude values of illuminance on the surface of the sea to be noted for, say, "noon" and sunset, clear and cloudy. Translation of these values to the approximate illuminance at the depth of the swimmer is often facilitated by noting that the illuminance, and, therefore, the adaptation luminance is reduced by a factor of 1/10 for each $\ln 10/K$ of depth, i.e., each $2.3/K$ unit of depth. Thus, if $K = 0.10$ per foot the natural illuminance decreases by a factor of 1/10 for each 23 feet of depth. Figures 2 and 2A of this report provide convenient illustrations of this concept.

5.4 Estimation of α and K

In some, but by no means all, waters the distance $2.3/K$ is about 50% greater than the distance $4/\alpha$; i.e., about $6/\alpha$; thus the natural illuminance (and the adaptation level) may decrease by a factor of 1/10 for each unit of depth equal to 1.5 times the horizontal distance at which a swimmer can see a large dark object at high light levels. If measured values of α and K are not available, these constants can be estimated by means of the relations $\alpha = 4/d$ and $K = 1.5/d$, where d is the horizontal sighting range for large dark objects at high light levels. The estimate of α is more reliable than the estimate of K.

5.5 Characterization of Natural Waters

For purposes of easy visualization, it is recommended that the clarity of natural waters be characterized by the distances $4/\alpha$ and $2.3/K$. In the clearest known natural waters* these distances are believed to be less than 230 feet and 340 feet, respectively. In the first numerical example given in Section 3.2 the distance $4/\alpha = 55$ feet and $2.3/K = 85$ feet; in the second, $4/\alpha = 9.3$ feet and $2.3/K = 13.5$ feet.

* Probable values: $\alpha = 0.017$ per foot

$K = 0.0067$ per foot at 480 millimicrons

$$.0237/\text{ft} \approx .071/\mu$$

at 550 nm

Hurlburt .047 /m = α for Distilled water
Tyler .068 /m = K for Crater Lake

.115 /m = $\alpha + K$

5.4 Estimation of α and K

In some, but by no means all, waters the distance $2.3/K$ is about 50% greater than the distance $4/\alpha$; i.e., about $6/\alpha$; thus the natural illuminance (and the adaptation level) may decrease by a factor of 1/10 for each unit of depth equal to 1.5 times the horizontal distance at which a swimmer can see a large dark object at high light levels. If measured values of α and K are not available, these constants can be estimated by means of the relations $\alpha = 4/d$ and $K = 1.5/d$, where d is the horizontal sighting range for large dark objects at high light levels. The estimate of α is more reliable than the estimate of K.

5.5 Characterization of Natural Waters

For purposes of easy visualization, it is recommended that the clarity of natural waters be characterized by the distances $4/\alpha$ and $2.3/K$. In the clearest known natural waters* these distances are believed to be less than 230 feet and 340 feet, respectively. In the first numerical example given in Section 3.2 the distance $4/\alpha = 55$ feet and $2.3/K = 85$ feet; in the second, $4/\alpha = 9.3$ feet and $2.3/K = 13.5$ feet.

* Probable values: $\alpha = 0.017$ per foot

$K = 0.0067$ per foot at 480 millimicrons

$$.0237/\text{ft} \approx .071/\text{m}$$

SIGHTING RANGE (FEET)

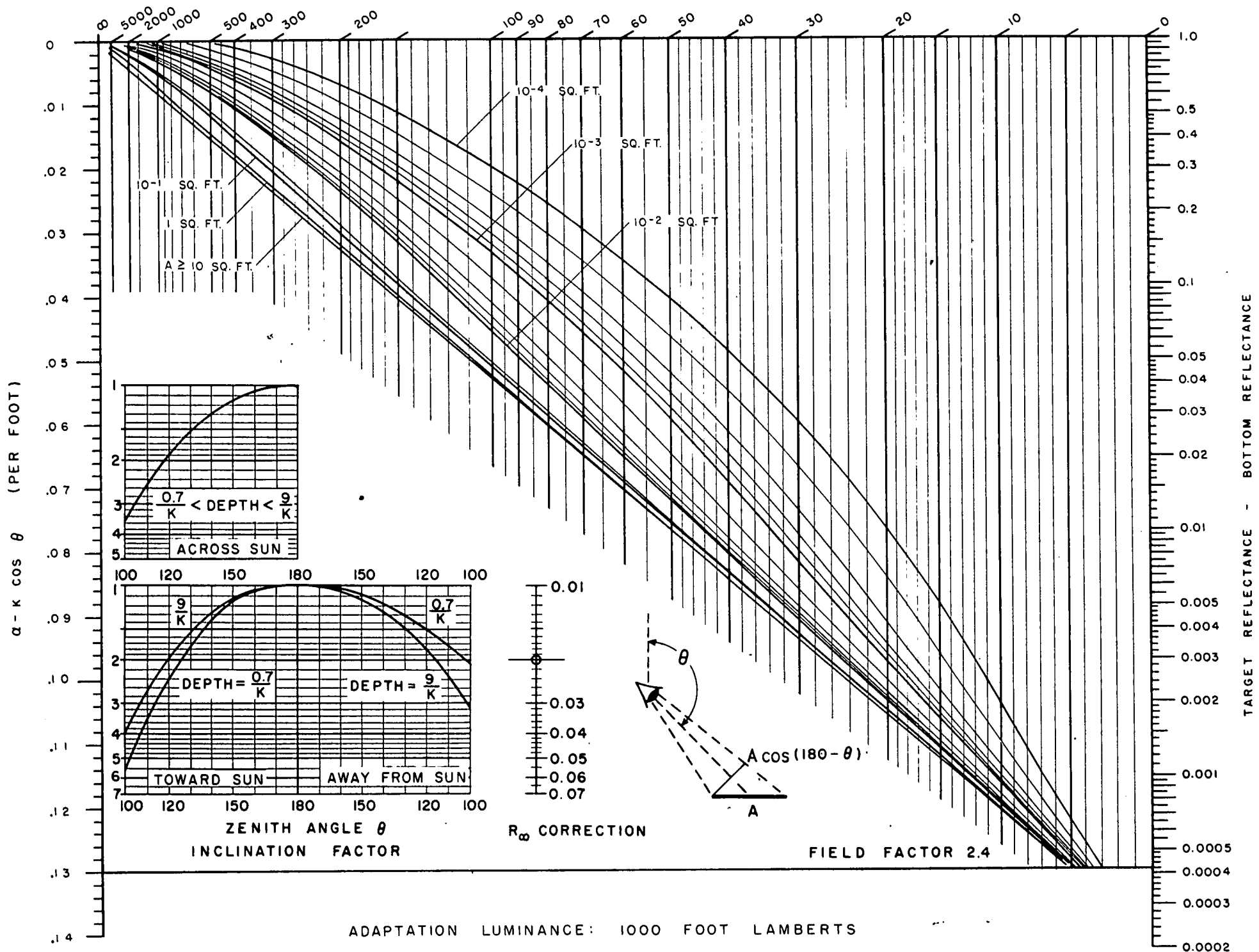

SIGHTING RANGE (FEET)

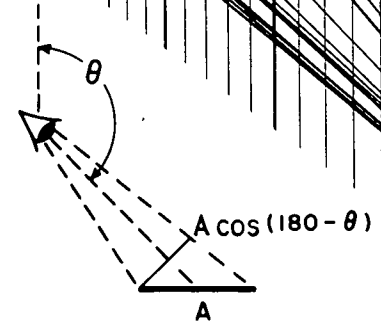
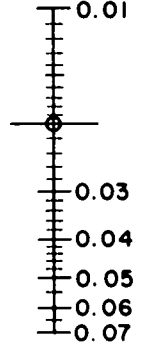
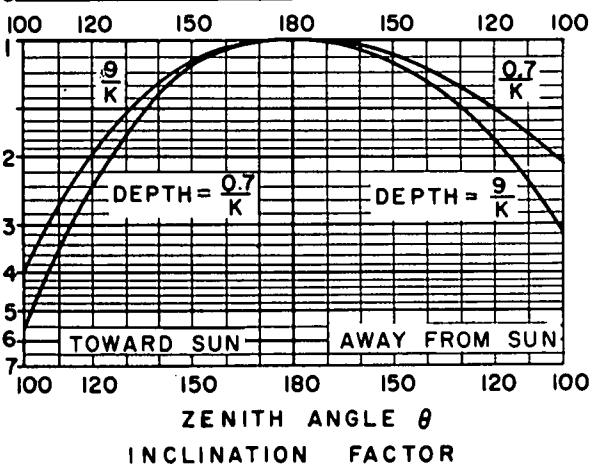
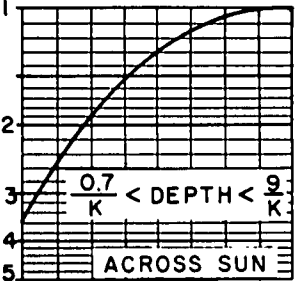
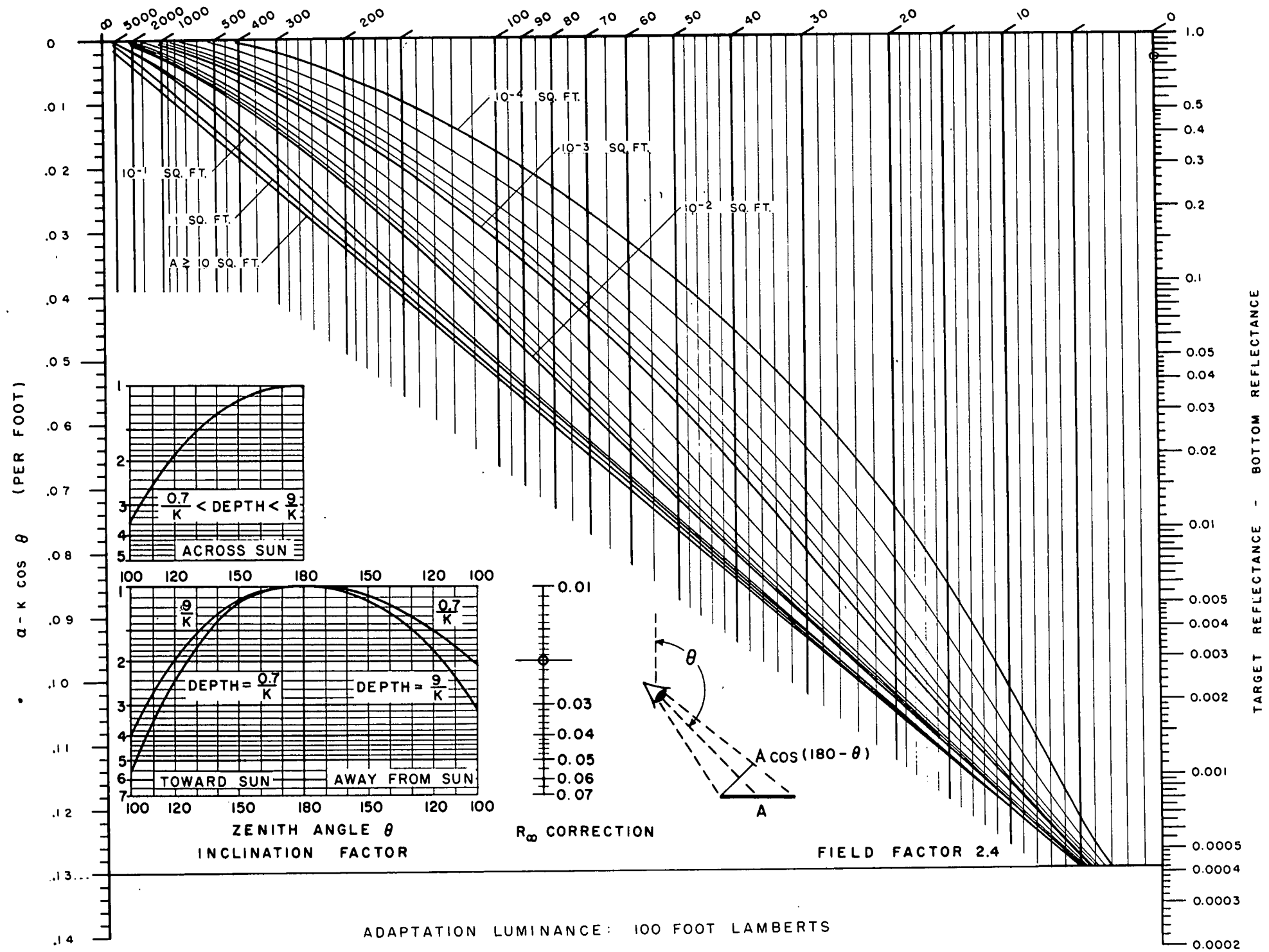

FIELD FACTOR 2.4

ADAPTATION LUMINANCE: 100 FOOT LAMBERTS

SIGHTING RANGE (FEET)

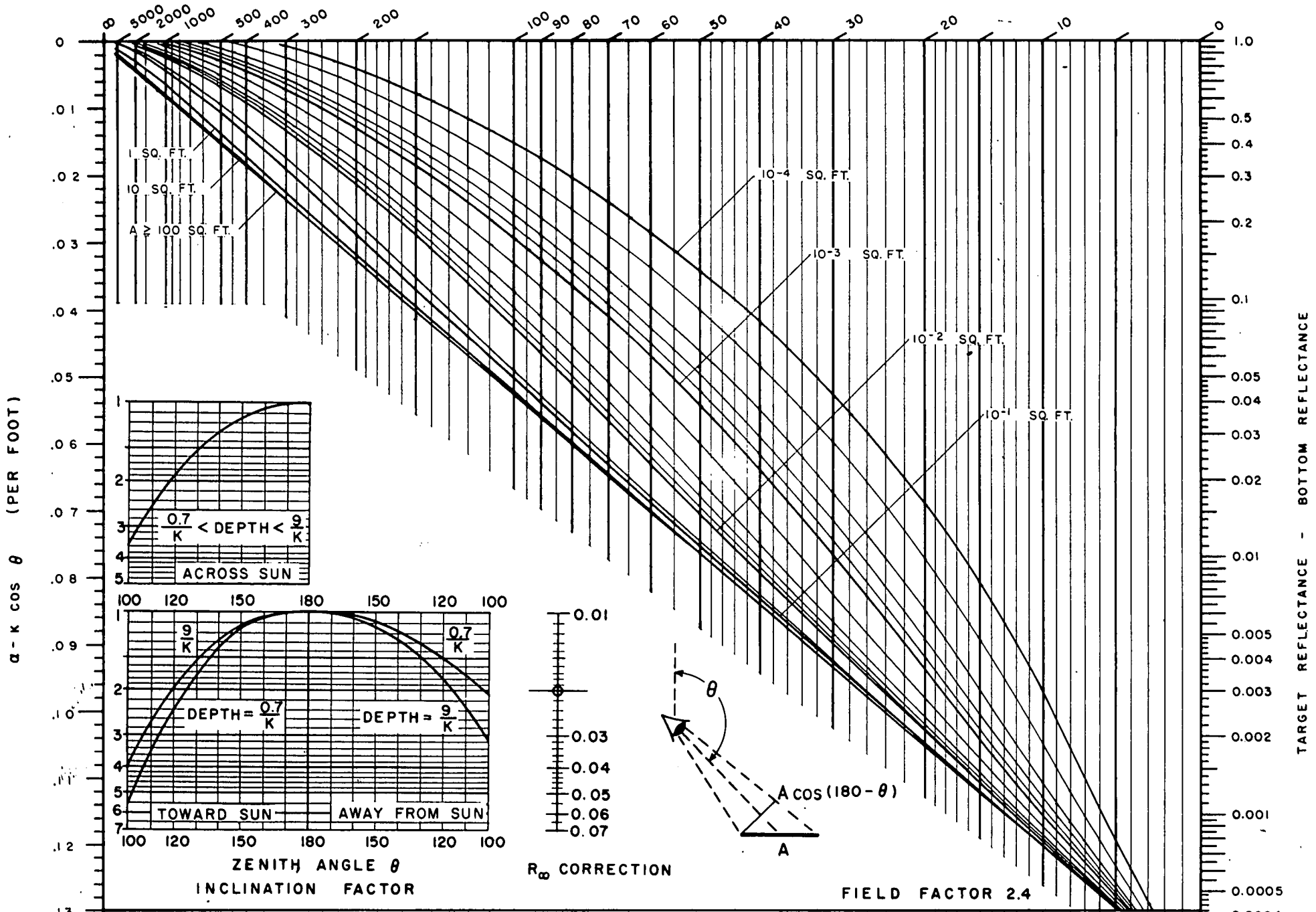

ADAPTATION LUMINANCE: 10 FOOT LAMBERTS

SIGHTING RANGE (FEET)

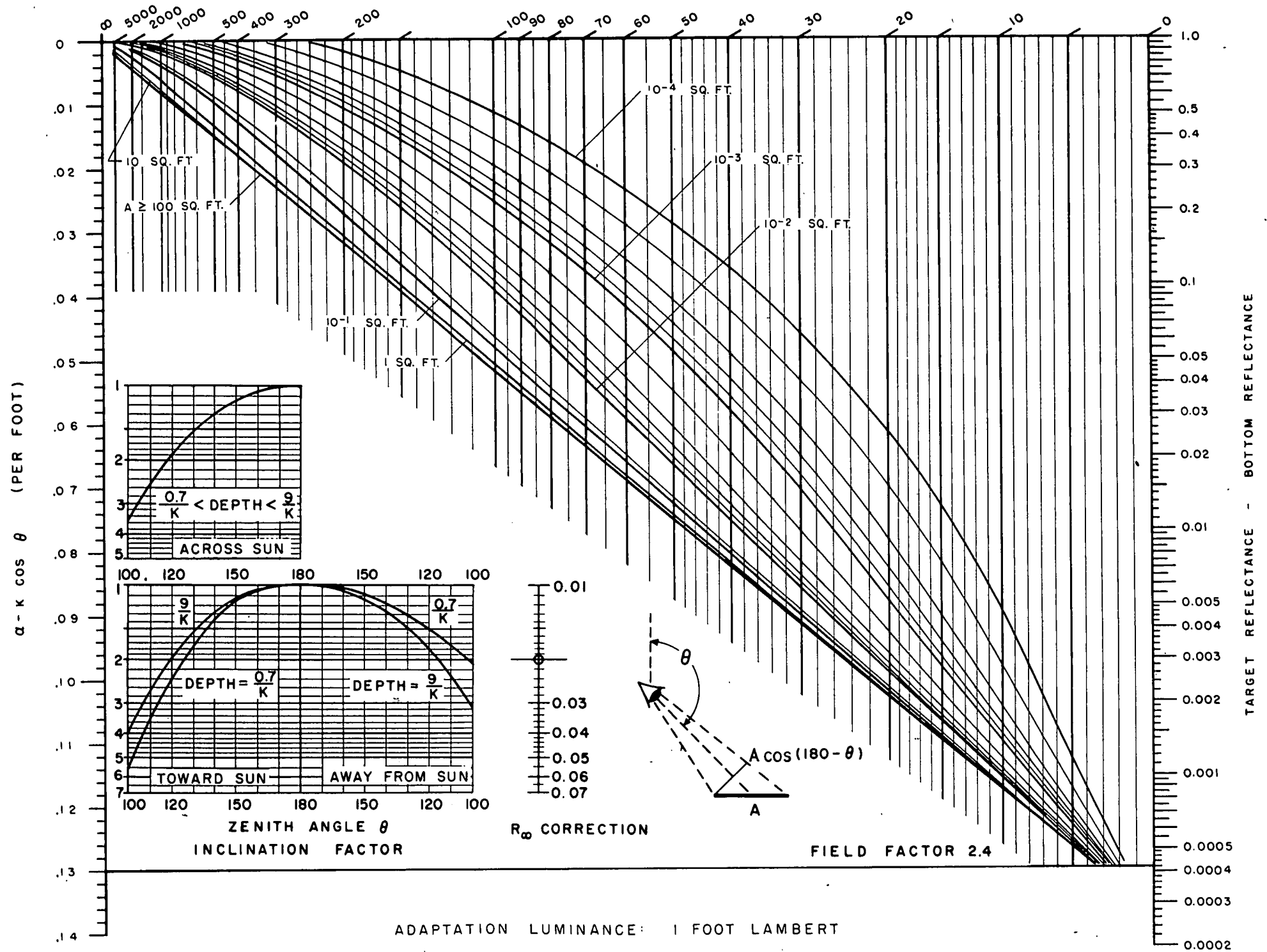

ADAPTATION LUMINANCE: 1 FOOT LAMBERT

SIGHTING RANGE (FEET)

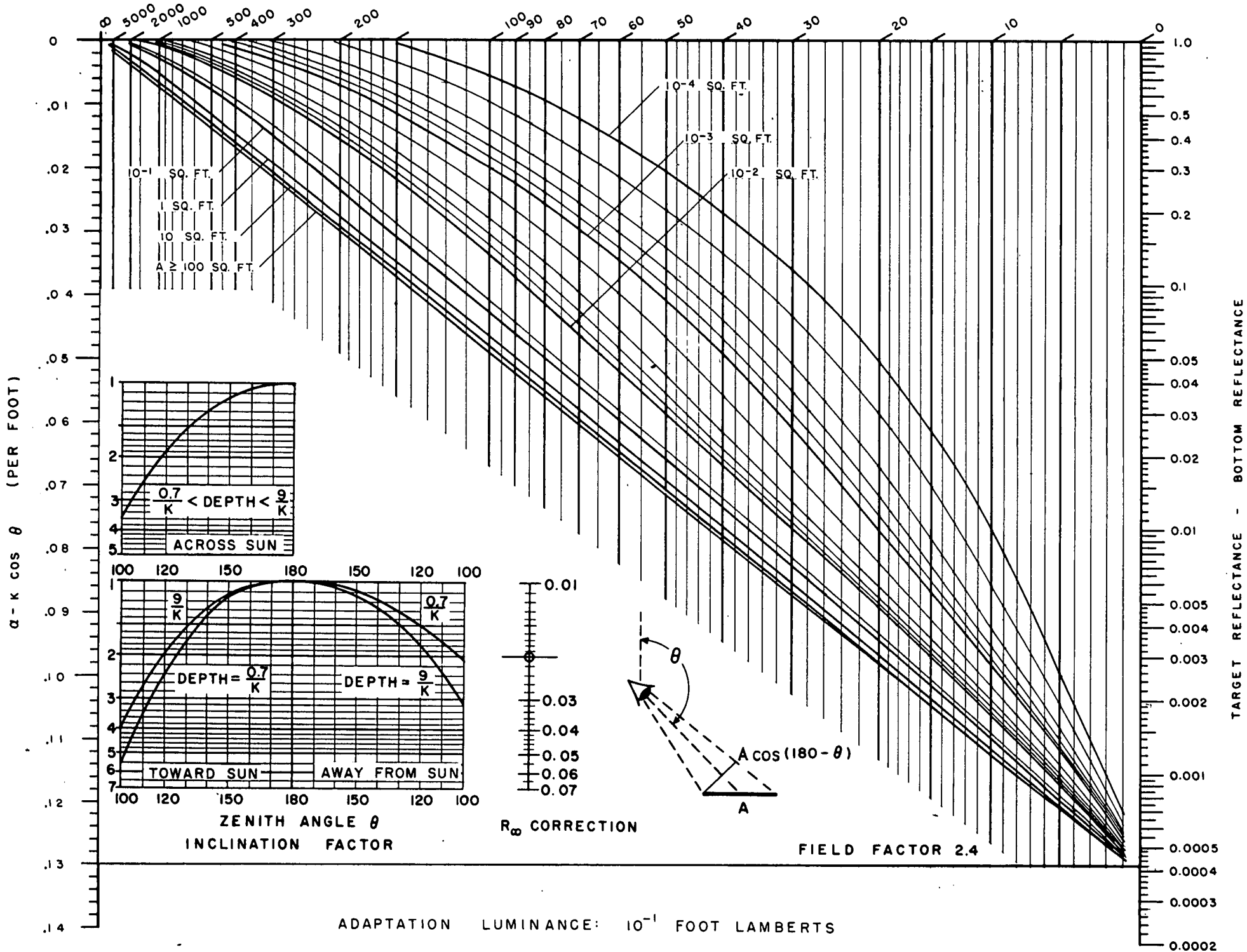

10⁻¹ SQ. FT.
1 SQ. FT.
10 SQ. FT.
A ≥ 100 SQ. FT.

10⁻⁴ SQ. FT.
10⁻³ SQ. FT.
10⁻² SQ. FT.

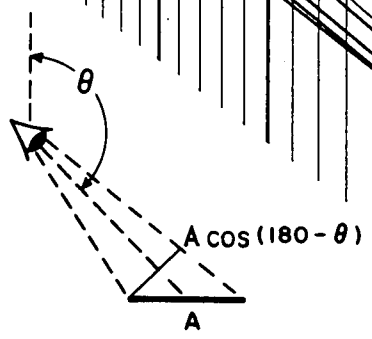
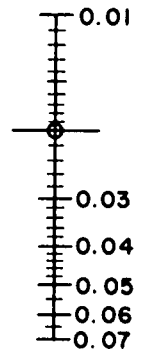
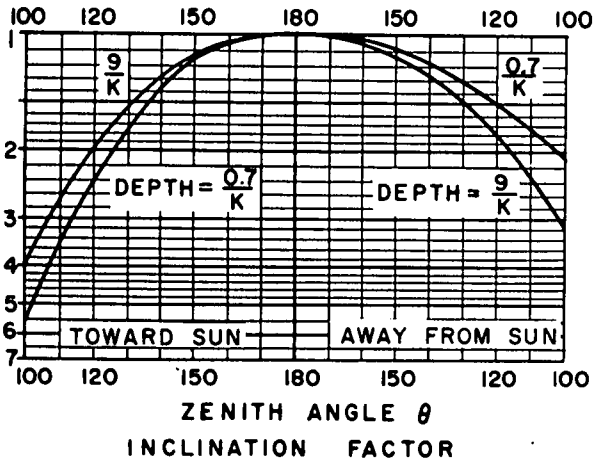
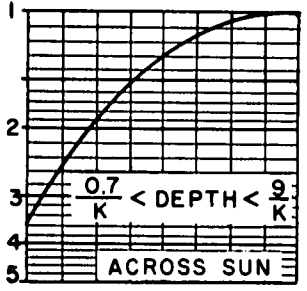

FIELD FACTOR 2.4

SIGHTING RANGE (FEET)

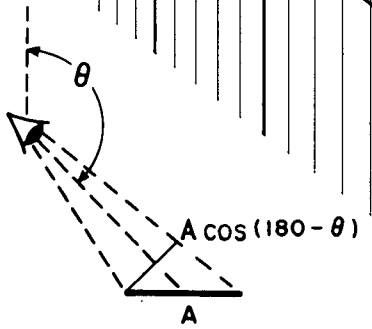
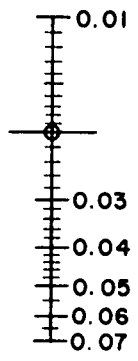
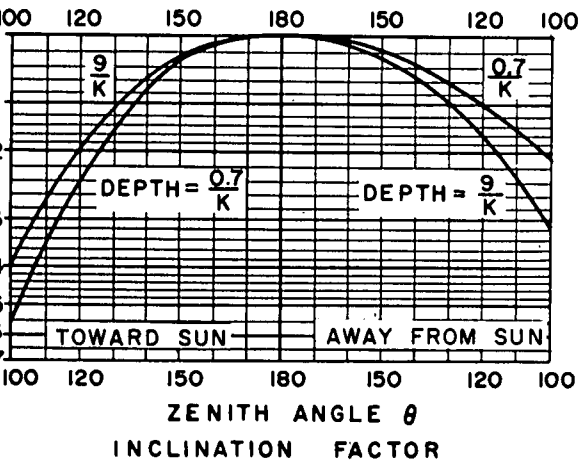
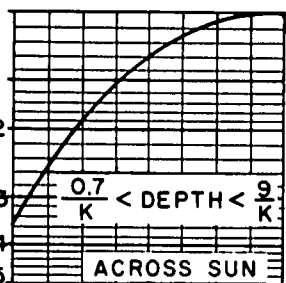
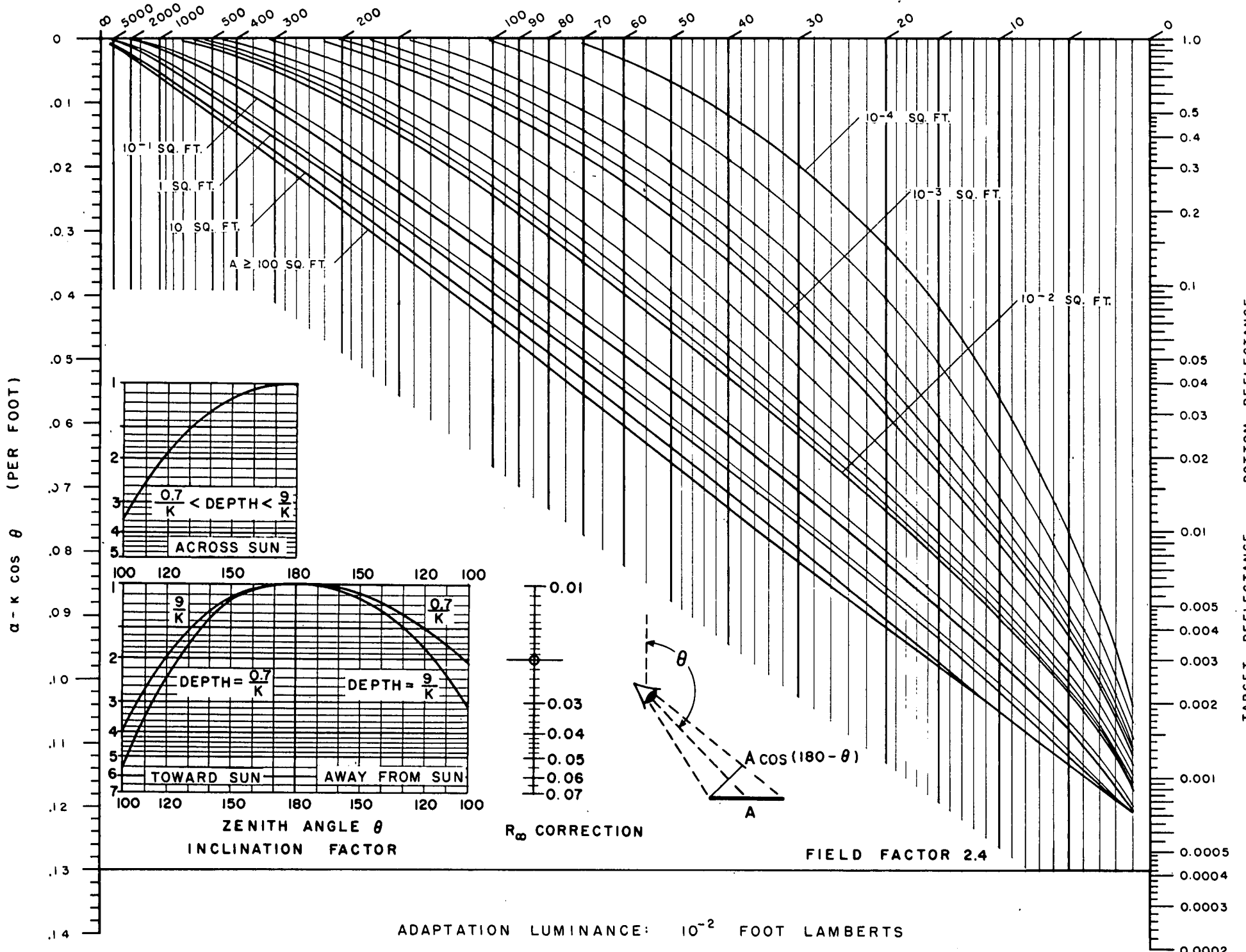

FIELD FACTOR 2.4

ADAPTATION LUMINANCE: 10^{-2} FOOT LAMBERTS

SIGHTING RANGE (FEET)

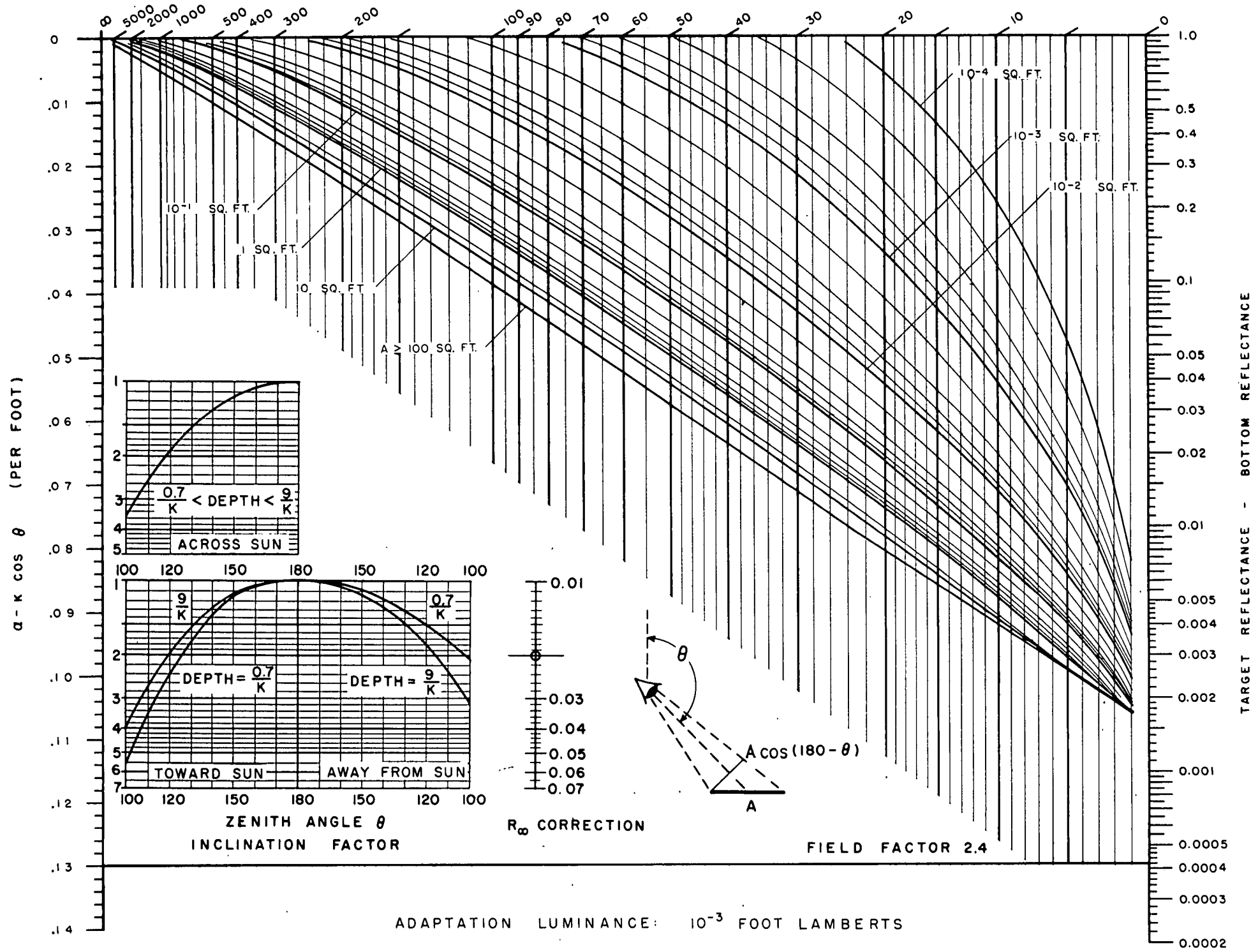

10⁻¹ SQ. FT.

1 SQ. FT.

10 SQ. FT.

A ≥ 100 SQ. FT.

10⁻⁴ SQ. FT.

10⁻³ SQ. FT.

10⁻² SQ. FT.

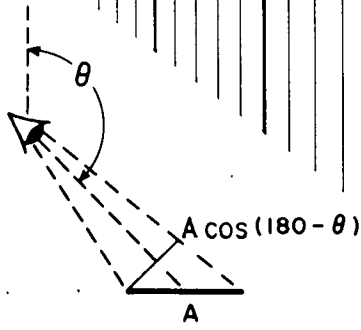
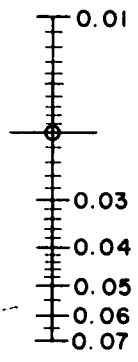
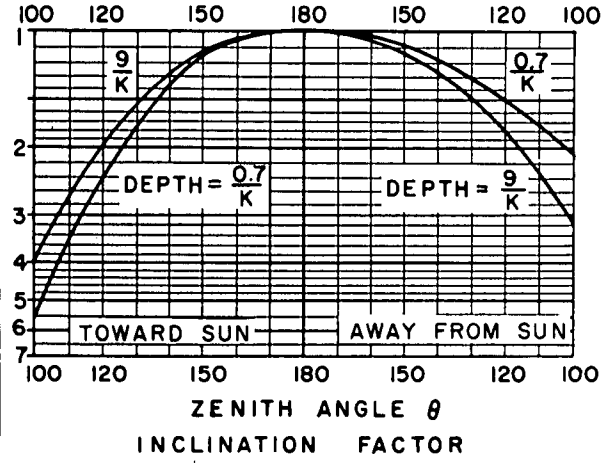
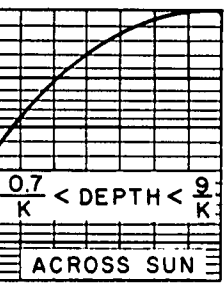

FIELD FACTOR 2.4

ADAPTATION LUMINANCE: 10⁻³ FOOT LAMBERTS

SIGHTING RANGE (FEET)

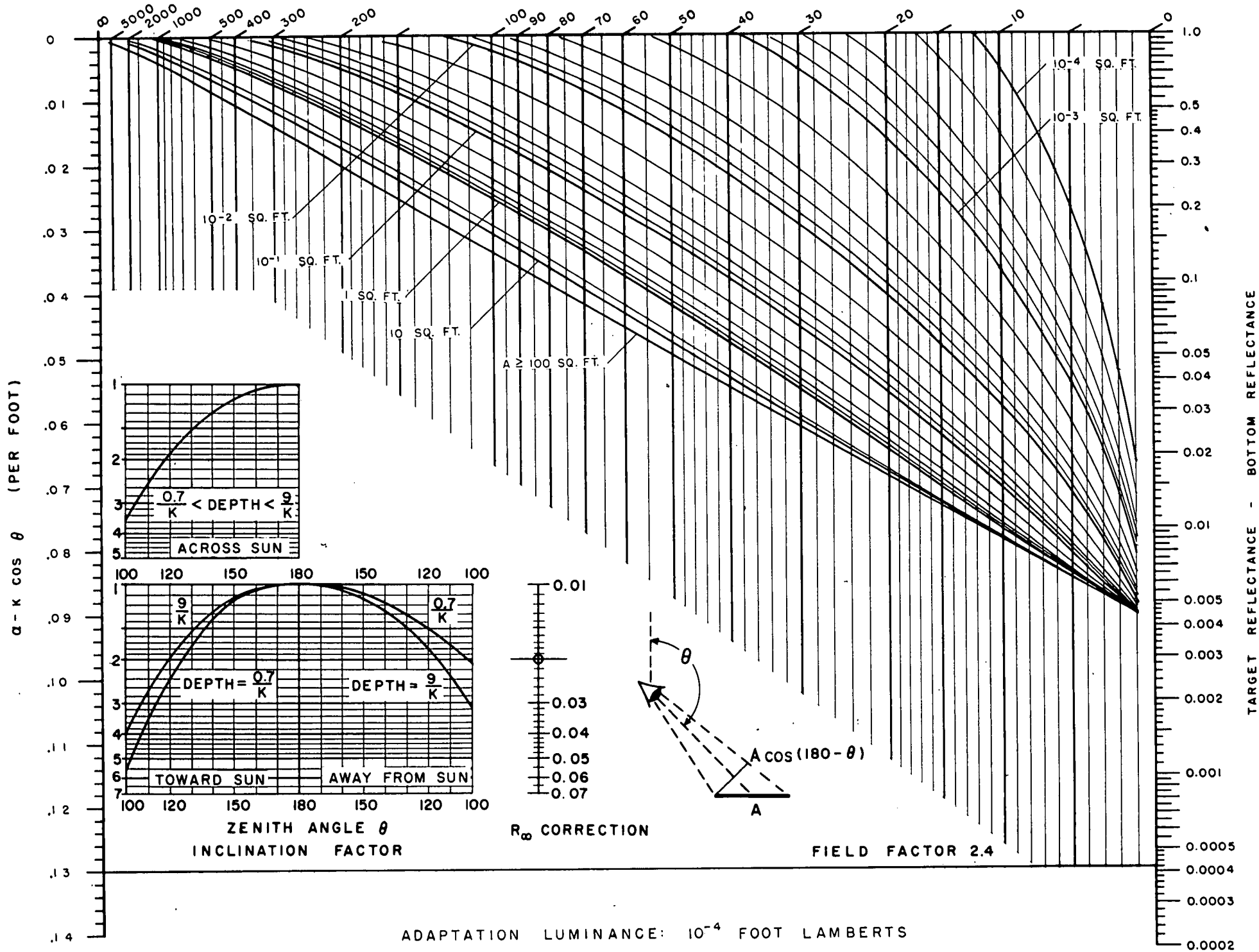

SIGHTING RANGE (FEET)

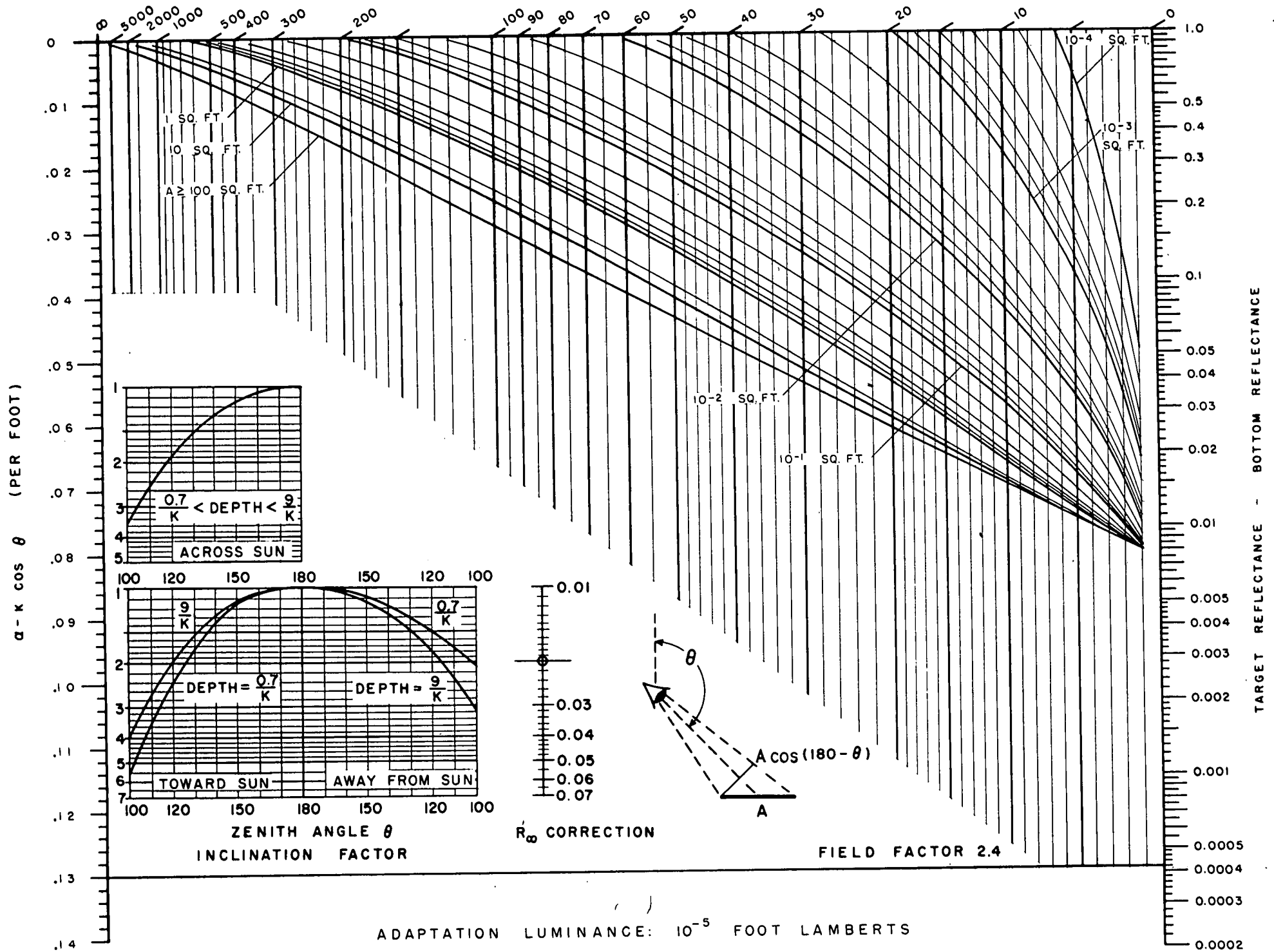

SIGHTING RANGE (FEET)

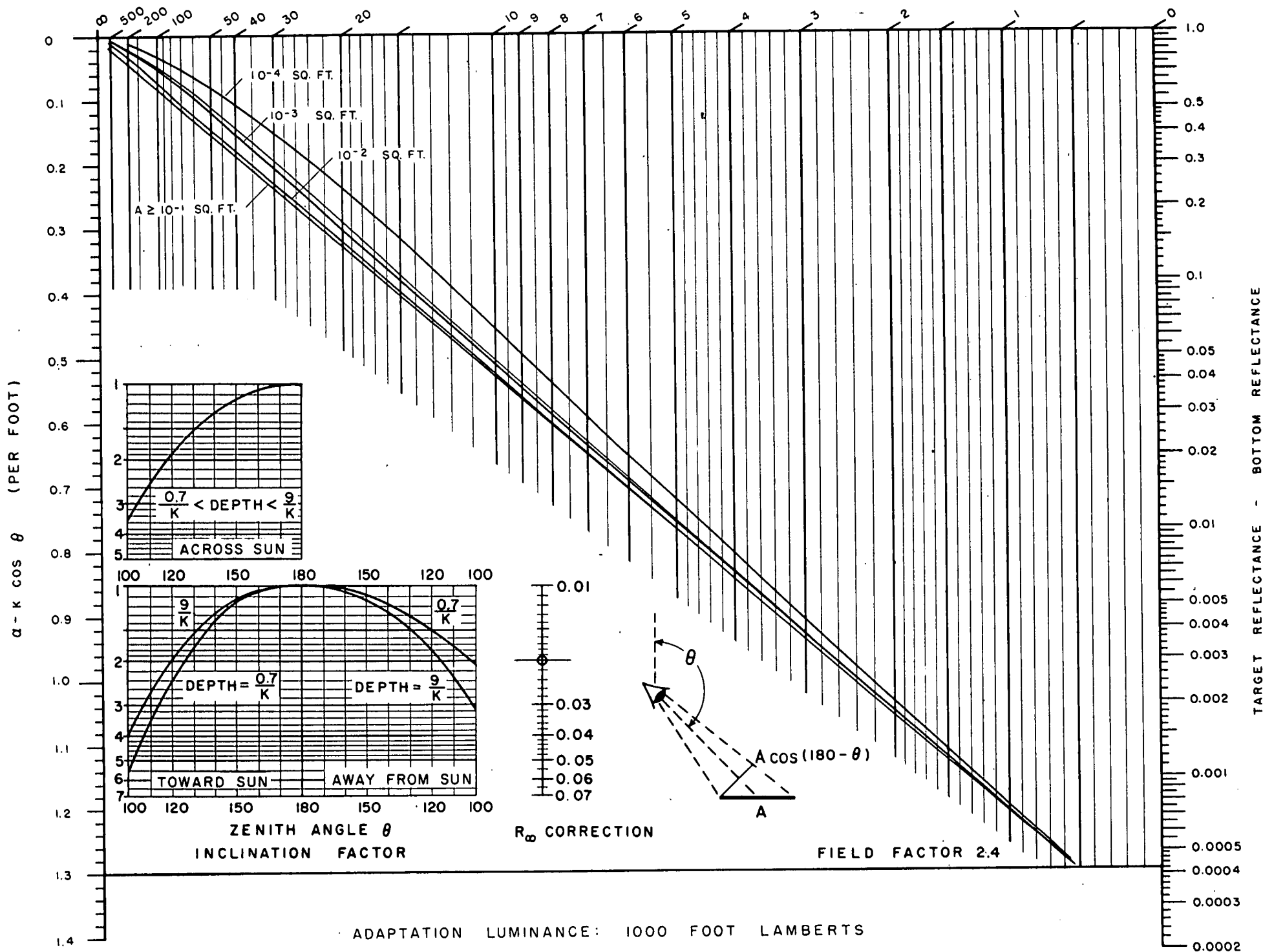

SIGHTING RANGE (FEET)

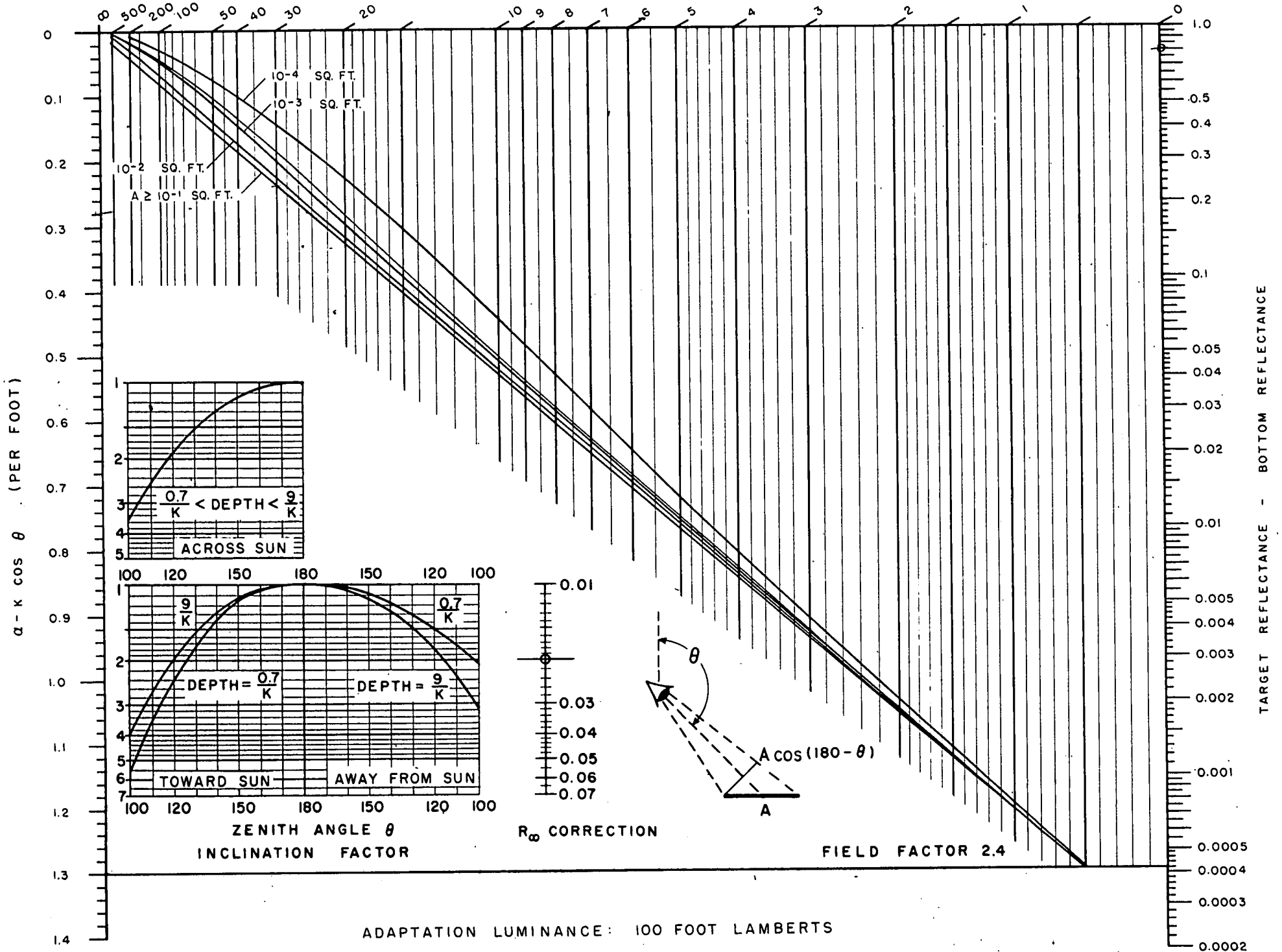

SIGHTING RANGE (FEET)

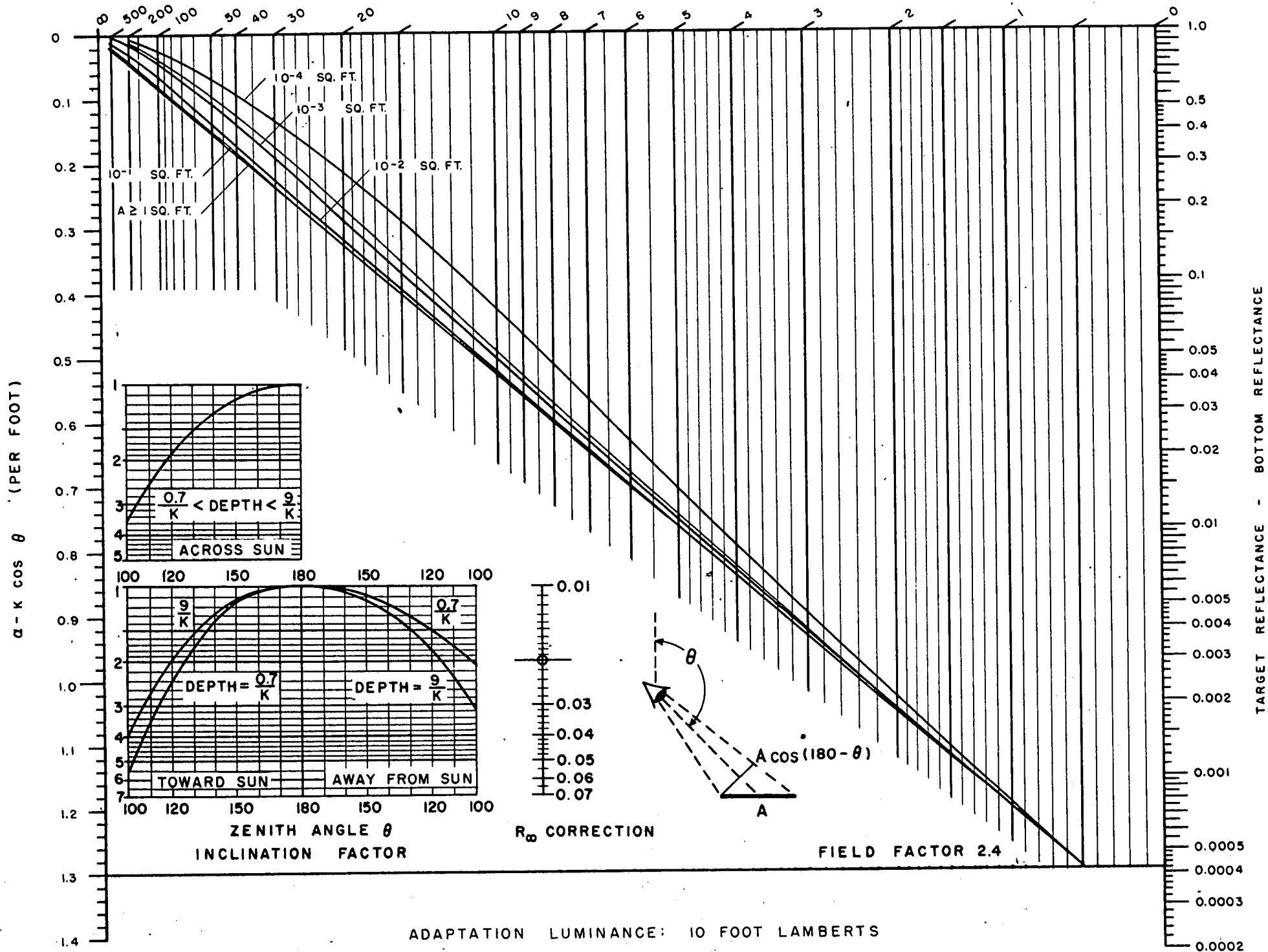

SIGHTING RANGE (FEET)

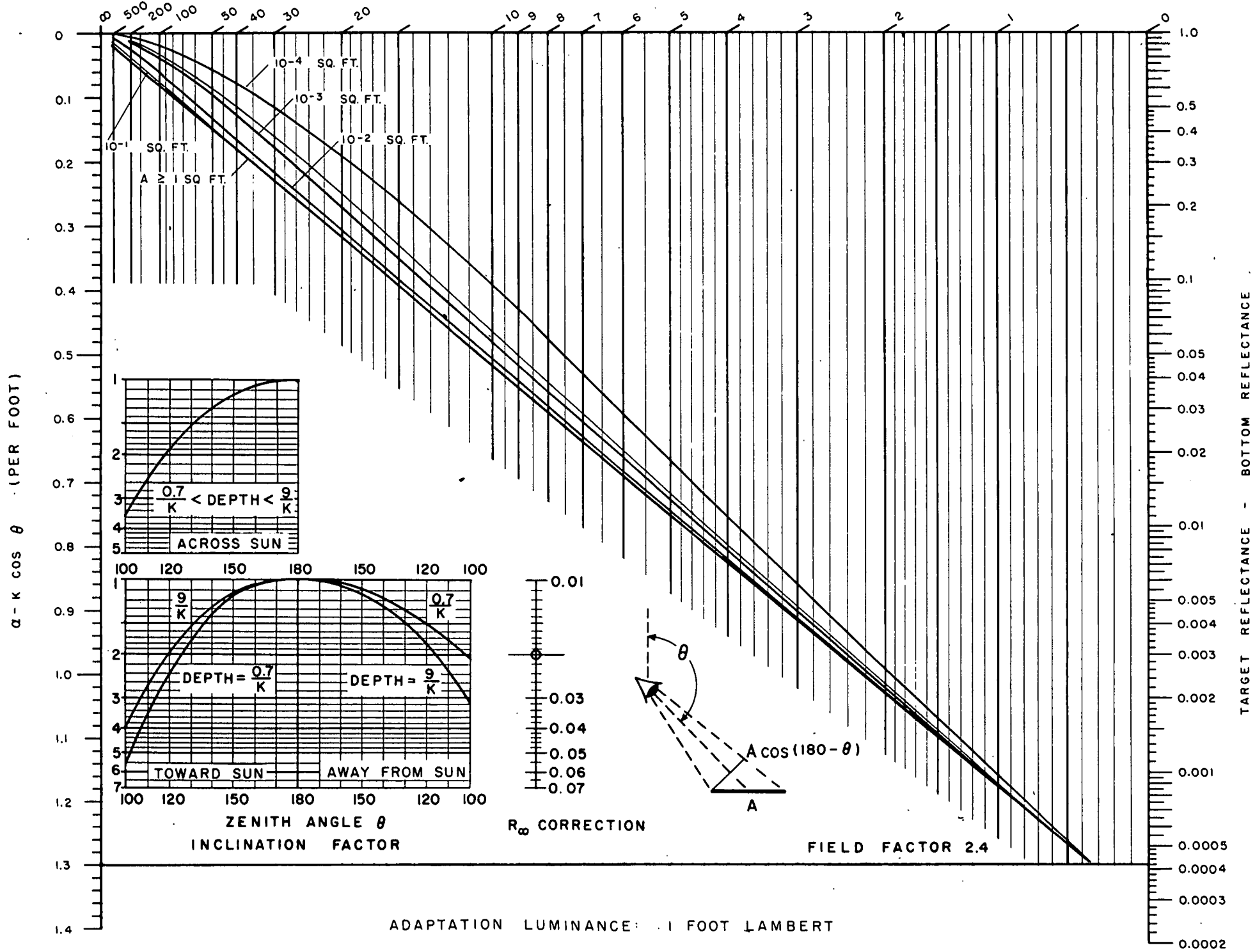

SIGHTING RANGE (FEET)

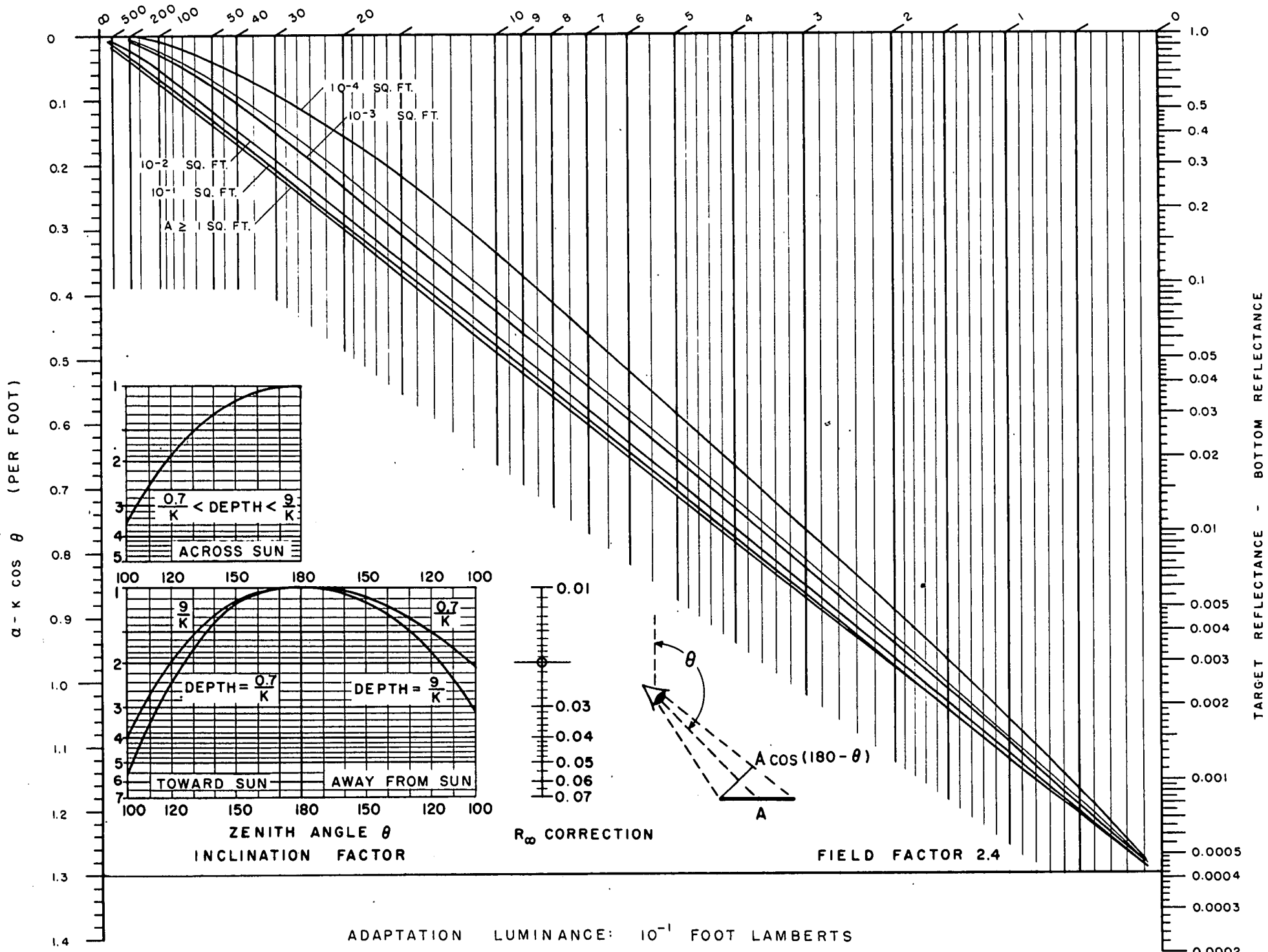

SIGHTING RANGE (FEET)

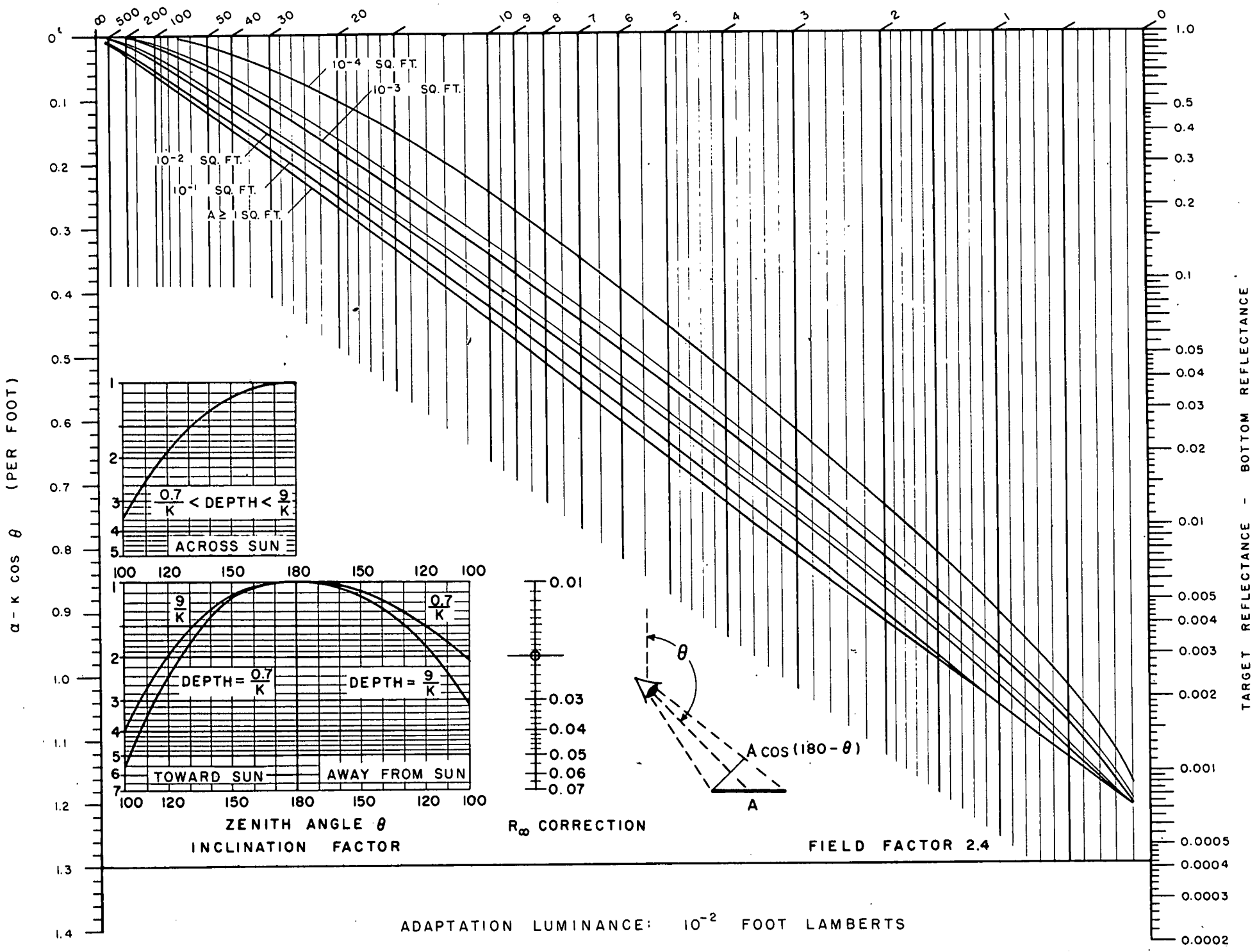

∞ 500 200 100 50 40 30 20 10 9 8 7 6 5 4 3 2 1 0

10⁻⁴ SQ. FT.
10⁻³ SQ. FT.
10⁻² SQ. FT.
10⁻¹ SQ. FT.
A ≥ 1 SQ. FT.

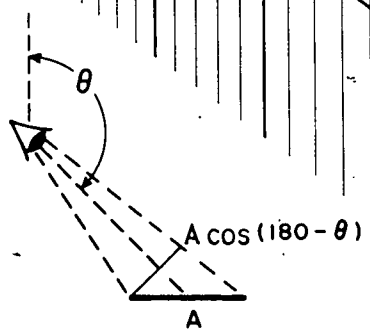
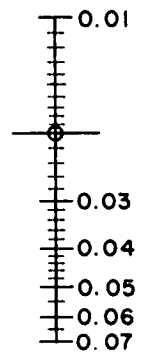
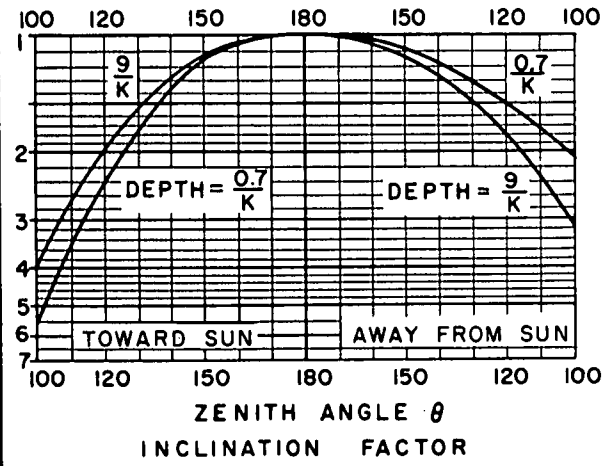
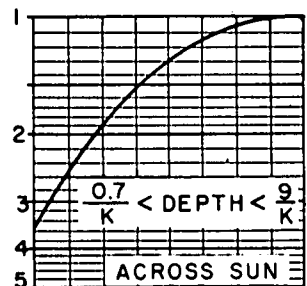

FIELD FACTOR 2.4

R_∞ CORRECTION

ADAPTATION LUMINANCE: 10⁻² FOOT LAMBERTS

TARGET REFLECTANCE - BOTTOM REFLECTANCE

SIGHTING RANGE (FEET)

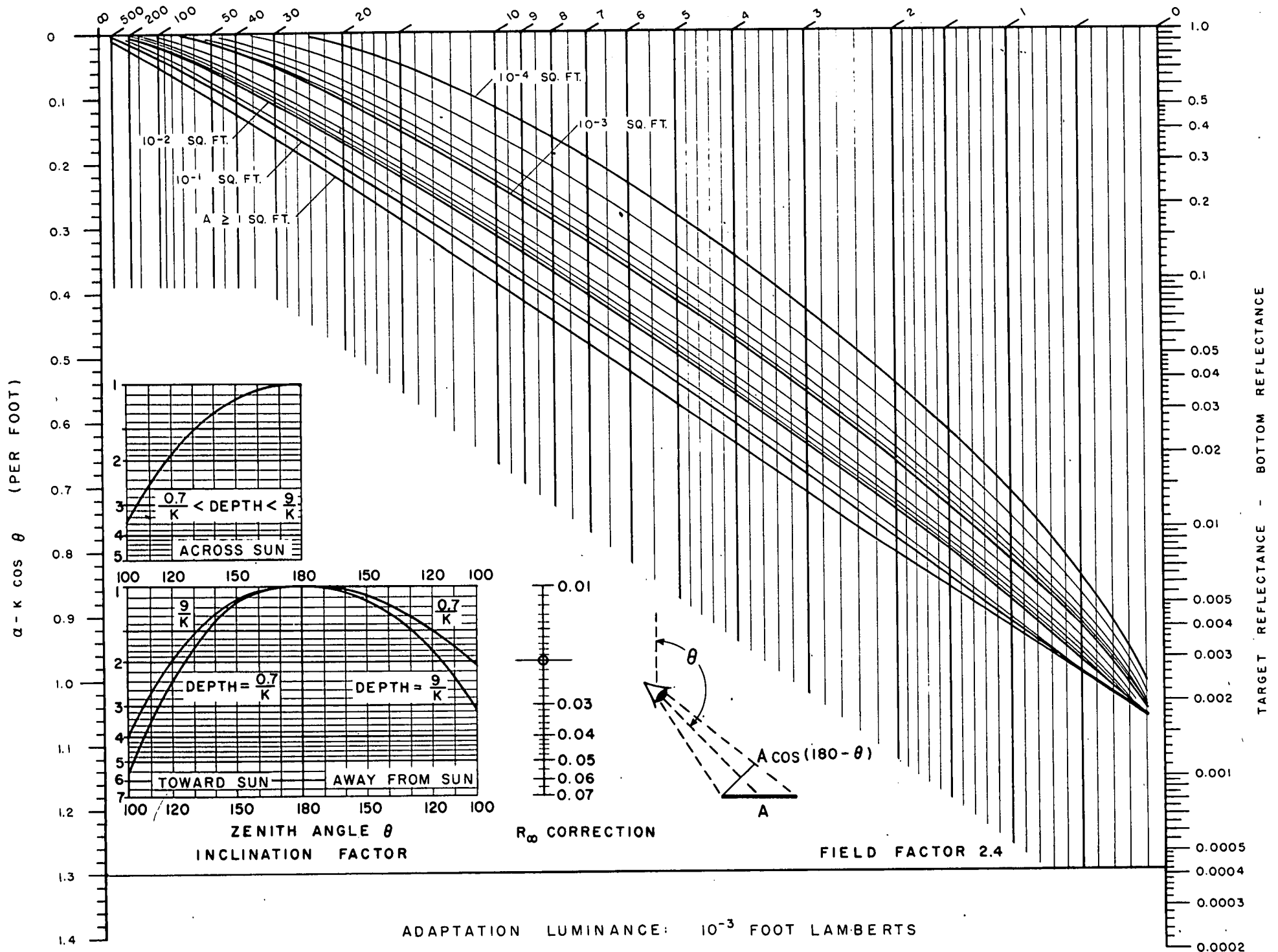

SIGHTING RANGE (FEET)

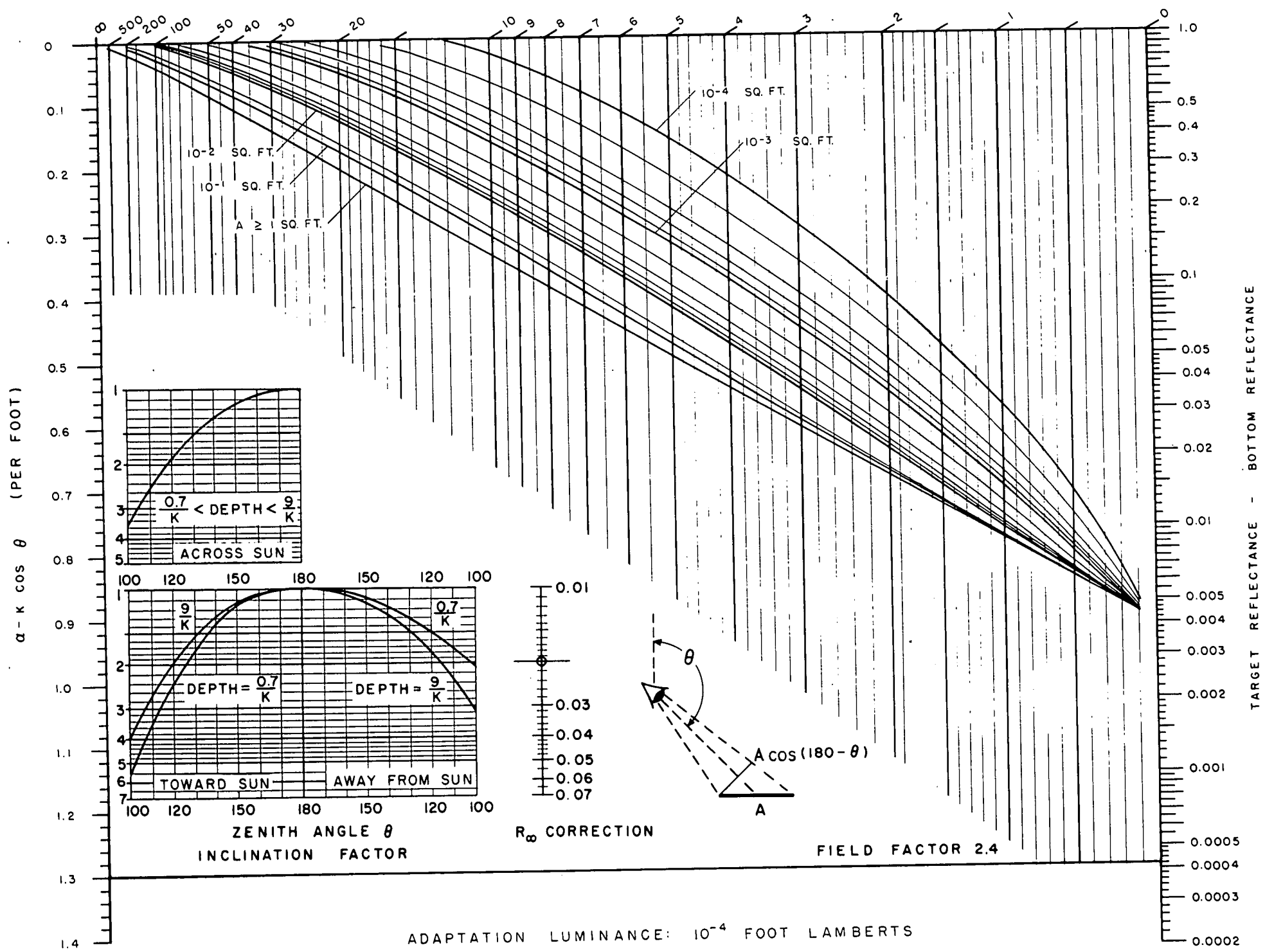

10⁻² SQ. FT.
10⁻¹ SQ. FT.
A ≥ 1 SQ. FT.

10⁻⁴ SQ. FT.

10⁻³ SQ. FT.

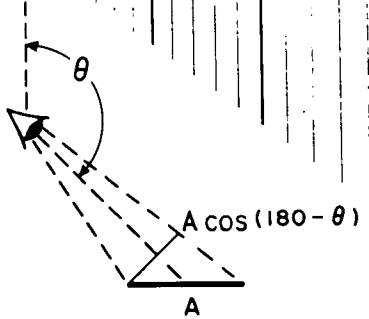
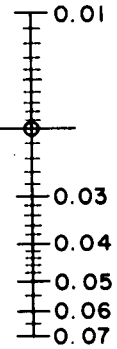
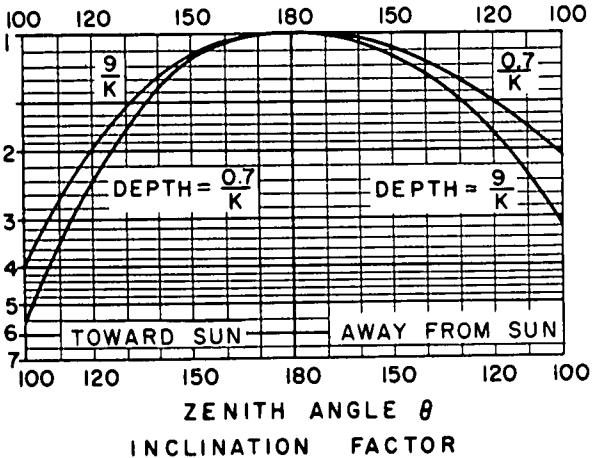
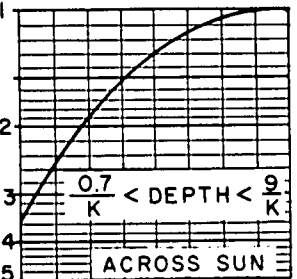

FIELD FACTOR 2.4

ADAPTATION LUMINANCE: 10⁻⁴ FOOT LAMBERTS

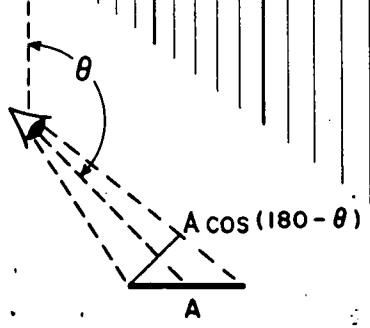
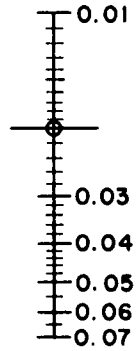
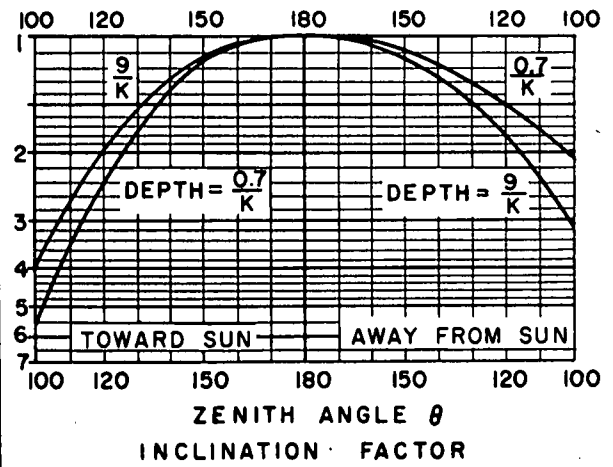
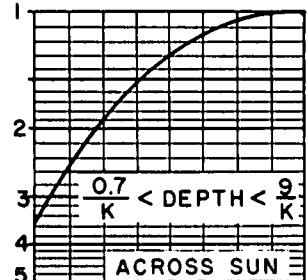
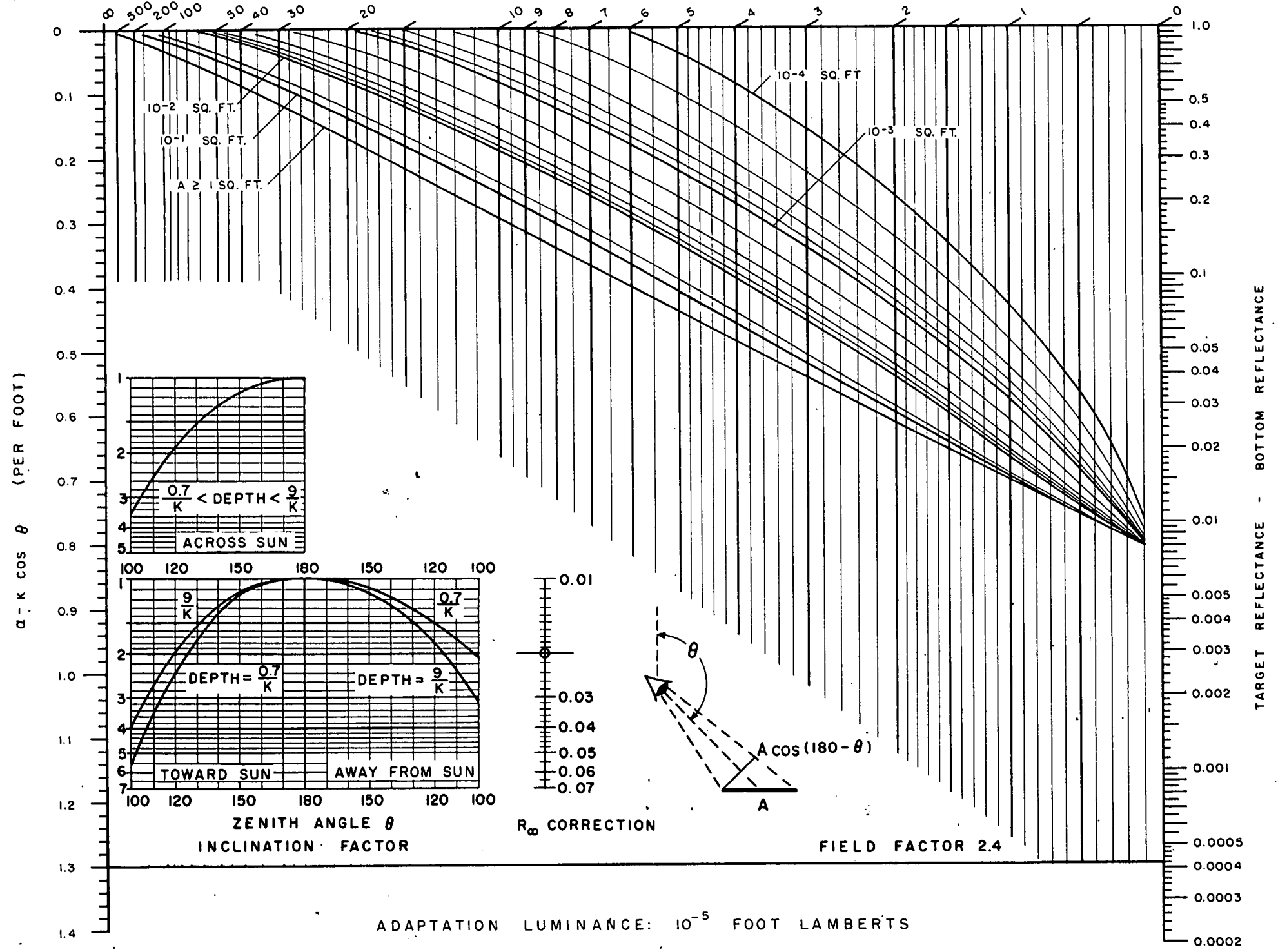

FIELD FACTOR 2.4

TARGET REFLECTANCE - BOTTOM REFLECTANCE

θ	$\text{Cos } \theta$	$\text{Cos}(180-\theta)$	θ	$\text{Cos } \theta$	$\text{Cos}(180-\theta)$
100	- 0.1736	+ 0.1736	141	- 0.7771	+ 0.7771
101	- 0.1908	+ 0.1908	142	- 0.7880	+ 0.7880
102	- 0.2079	+ 0.2079	143	- 0.7986	+ 0.7986
103	- 0.2250	+ 0.2250	144	- 0.8090	+ 0.8090
104	- 0.2419	+ 0.2419	145	- 0.8192	+ 0.8192
105	- 0.2588	+ 0.2588	146	- 0.8290	+ 0.8290
106	- 0.2756	+ 0.2756	147	- 0.8387	+ 0.8387
107	- 0.2924	+ 0.2924	148	- 0.8480	+ 0.8480
108	- 0.3090	+ 0.3090	149	- 0.8572	+ 0.8572
109	- 0.3256	+ 0.3256	150	- 0.8660	+ 0.8660
110	- 0.3420	+ 0.3420			
111	- 0.3584	+ 0.3584	151	- 0.8746	+ 0.8746
112	- 0.3746	+ 0.3746	152	- 0.8829	+ 0.8829
113	- 0.3907	+ 0.3907	153	- 0.8910	+ 0.8910
114	- 0.4067	+ 0.4067	154	- 0.8988	+ 0.8988
115	- 0.4226	+ 0.4226	155	- 0.9063	+ 0.9063
116	- 0.4384	+ 0.4384	156	- 0.9135	+ 0.9135
117	- 0.4540	+ 0.4540	157	- 0.9205	+ 0.9205
118	- 0.4695	+ 0.4695	158	- 0.9272	+ 0.9272
119	- 0.4848	+ 0.4848	159	- 0.9336	+ 0.9336
120	- 0.5000	+ 0.5000	160	- 0.9397	+ 0.9397
121	- 0.5150	+ 0.5150	161	- 0.9455	+ 0.9455
122	- 0.5299	+ 0.5299	162	- 0.9511	+ 0.9511
123	- 0.5446	+ 0.5446	163	- 0.9563	+ 0.9563
124	- 0.5592	+ 0.5592	164	- 0.9613	+ 0.9613
125	- 0.5736	+ 0.5736	165	- 0.9659	+ 0.9659
126	- 0.5878	+ 0.5878	166	- 0.9703	+ 0.9703
127	- 0.6018	+ 0.6018	167	- 0.9744	+ 0.9744
128	- 0.6157	+ 0.6157	168	- 0.9781	+ 0.9781
129	- 0.6293	+ 0.6293	169	- 0.9816	+ 0.9816
130	- 0.6428	+ 0.6428	170	- 0.9848	+ 0.9848
131	- 0.6561	+ 0.6561	171	- 0.9877	+ 0.9877
132	- 0.6691	+ 0.6691	172	- 0.9903	+ 0.9903
133	- 0.6820	+ 0.6820	173	- 0.9925	+ 0.9925
134	- 0.6947	+ 0.6947	174	- 0.9945	+ 0.9945
135	- 0.7071	+ 0.7071	175	- 0.9962	+ 0.9962
136	- 0.7193	+ 0.7193	176	- 0.9976	+ 0.9976
137	- 0.7314	+ 0.7314	177	- 0.9986	+ 0.9986
138	- 0.7431	+ 0.7431	178	- 0.9994	+ 0.9994
139	- 0.7547	+ 0.7547	179	- 0.9998	+ 0.9998
140	- 0.7660	+ 0.7660	180	- 1.0000	+ 1.0000