

AN INSTRUMENT FOR THE MEASUREMENT OF THE VOLUME ABSORPTION  
COEFFICIENT OF HORIZONTALLY STRATIFIED WATER

John E. Tyler

Contract NObs-72039  
Task 5  
Report No. 5-4

February 1960

TK 491

Report No. 5-4

An Instrument for the Measurement of the Volume Absorption  
Coefficient of Horizontally Stratified Water

John E. Tyler

INTRODUCTION

For the solution of many problems having to do with underwater photography, vision, and television it is important to know the absorbing and scattering properties of the water. By this is meant the separate values of the absorption coefficient and the scattering coefficient.

Instrumentation has already been devised to measure the total attenuation coefficient, which is the sum of the absorption and scattering coefficients and consequently it is only necessary to measure one of the two latter coefficients to evaluate all three.

Figures 1, 2a and 2b are engineering sketches of a proposed instrument for measuring the absorption coefficient of ocean or lake water in situ.

INSTRUMENT

The discussion of the problem of developing instrumentation for the determination of the absorption coefficient will be divided into three parts:

TOP VIEW

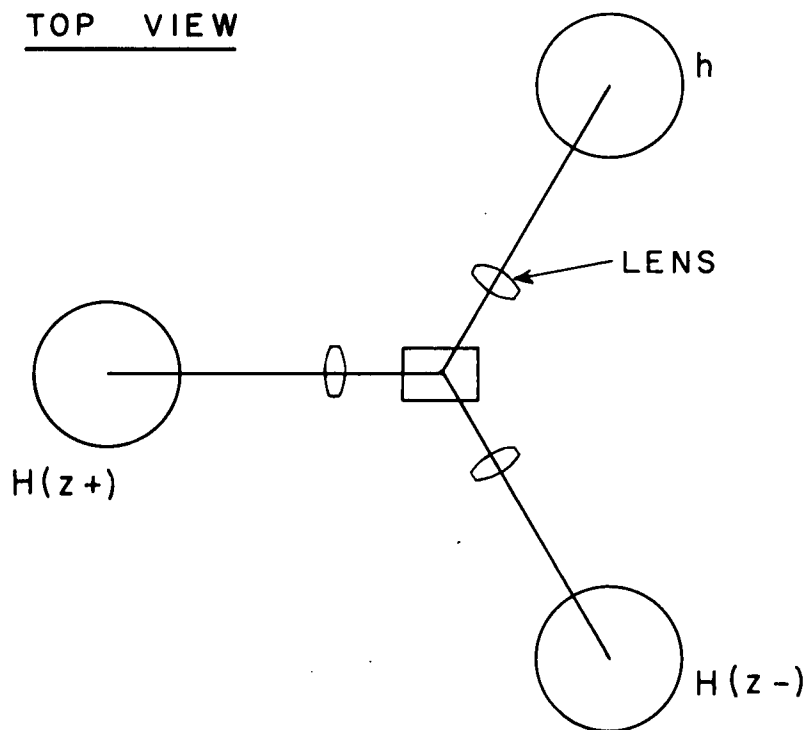

SIDE VIEW

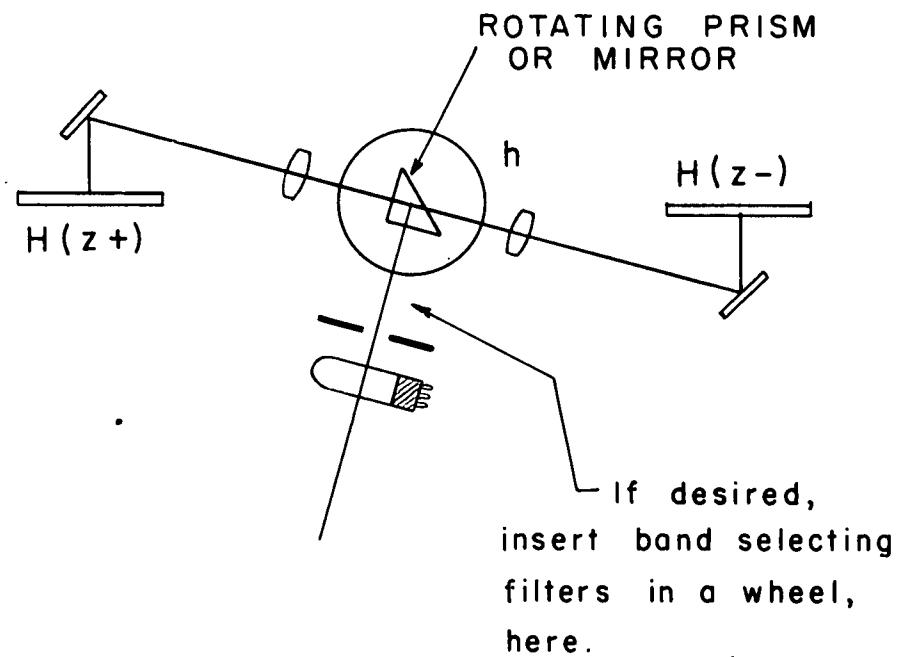
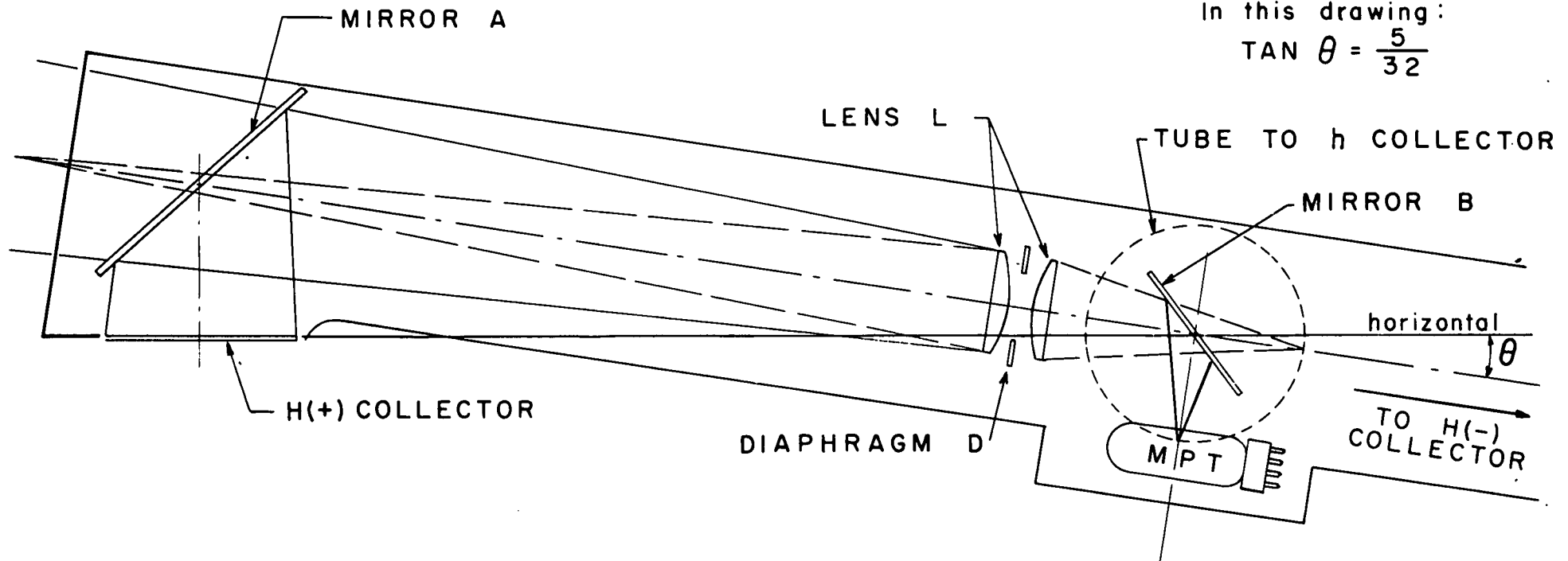

Figure 1. Schematic drawing of Absorption - meter

m	y	f	s
.2	10	9.17	55

In this drawing:

$$\text{TAN } \theta = \frac{5}{32}$$



m = magnification

y = diameter of H(+) collector (CM)

f = focal length of lens (CM)

s = object distance (CM)

Figure 2a - Irradiance measuring arm of proposed Absorption-meter.

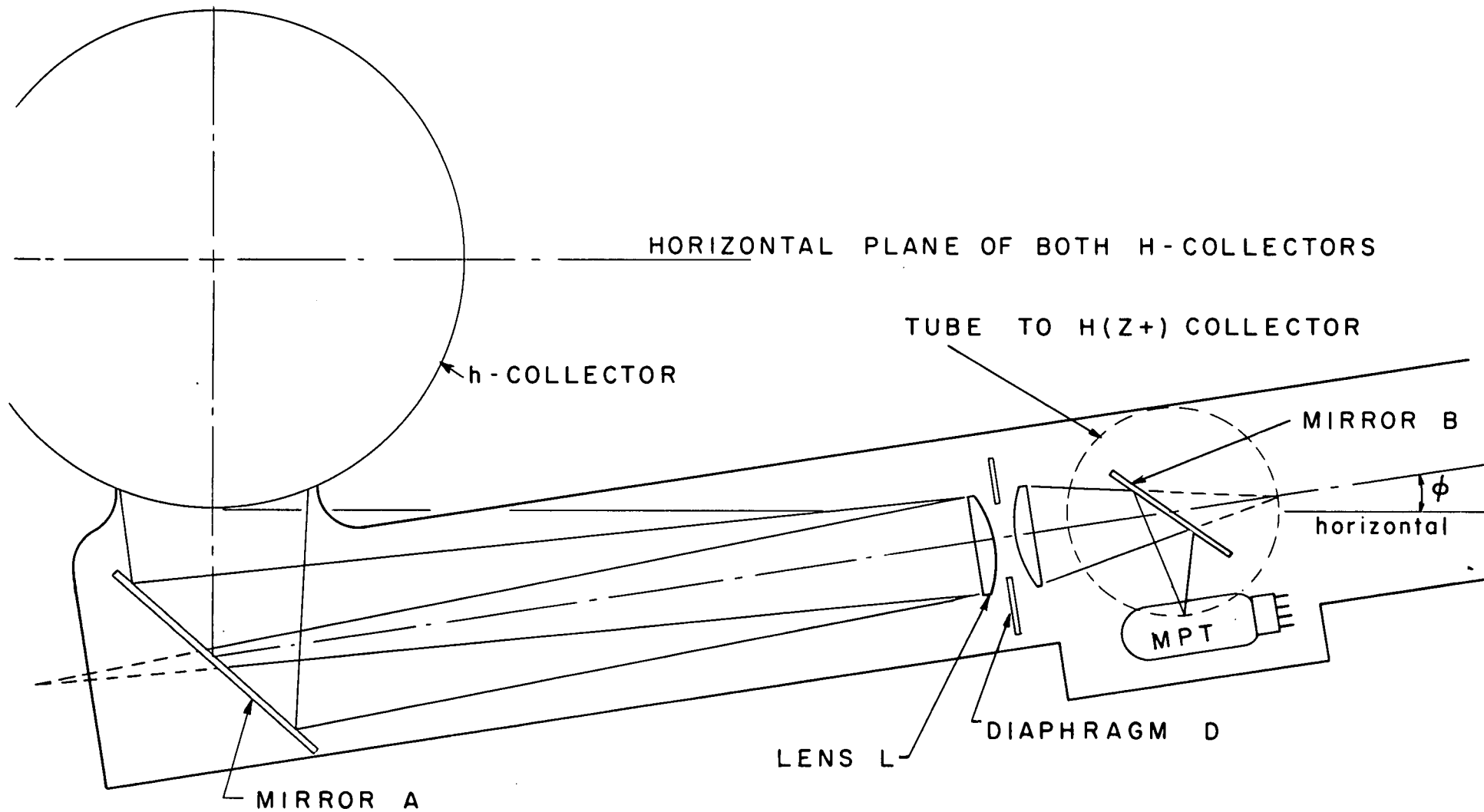

Angle  $\phi$  will have to be adjusted  
 to final size of h-collector and  
 mount.

Figure 2b

Part I. Probe: The development of a suitable probe for simultaneously measuring and reporting the quantities required for the determination of the absorption coefficient.

Part II. Optical Components: The selection or development of photoelectric transducers with optical coupling which will produce signals proportional to the required optical quantities as defined in equations (4), (5), and (6).

Part III. Data Recording: The selection or development of methods for recording and processing the data to obtain the volume absorption coefficient.

#### Part I. Probes

The various probes that suggest themselves can be grouped into three broad categories:

1. Multiple-probe, multiple-phototube types
2. Single-probe, multiple-phototube types
3. Single-probe, single-phototube types

Types under category 1 suffer from many serious disadvantages and will not be considered in this report.

A single-probe, multiple-photocell type instrument was built and described to the Optical Society of America (Tyler 1955)<sup>1</sup> in 1955. Experience with this early prototype indicates that it should be possible to design a practical single-probe, multiple-phototube type instrument with good time resolution which would be a satisfactory device for obtaining the absorption coefficient. Such an instrument would contain three phototubes and would suffer the intercalibration problems and complexities inherent to three phototube operation. Because of this, no further discussion will be given in this report to instruments under category 2.

By far the most rewarding design for an absorption-meter would be a single-probe, single-phototube type instrument (category 3). This report will be devoted to a discussion of a single-probe, single-phototube instrument which would have many advantages over other types. For example:

It would be mechanically simple requiring only one phototube housing, one filter wheel, or one filter holder.

It would be light in weight.

It would create minimum perturbation of the light field.

It would be electrically simple, requiring few leads in the cable, only one high-voltage power supply, and only one signal chassis.

It would be optically simple with respect to filters and intercalibration.

It would be simple to maintain in calibration.

It would be comparatively inexpensive.

---

<sup>1</sup>

J. E. Tyler, "The Measurement of Light in the Sea," JOSA 45, 904A, 1955

The basic design features of this single-probe, single-phototube type design are shown diagrammatically in Figure (1). In this design the optical collectors are located at the ends of three hollow arms which are shown symmetrically spaced around a circle. The arms are all located with their axes in the same plane. The plane, however, is tilted so that the surfaces of the downwelling irradiance collector and of the upwelling irradiance collector, and also the center of the spherical irradiance collector can all lie in the same horizontal plane.

A system of mirrors and lenses directs the flux from each collector down the axis of each arm to the center of the probe where a rotating mirror, or prism, sequentially redirects the flux along its axis of rotation to a phototube. For maximum convenience the axis of rotation of the rotating mirror is made perpendicular to the plane in which lie the optical axes of the three arms. A more detailed drawing of one configuration is given as Figure 2a and 2b (only one arm is shown in each drawing).

The irradiance collector in Figure (2a) is shown 10 cm in diameter. Mirror A (and its counterpart in the other two arms) is fixed in position to direct the flux to the mirror B. Each tube is provided with an  $f/2$  lens, L, and factory-adjustable diaphragm D, to control the flux received by the phototube and to permit

optically setting the three collectors in relative calibration. An alternative design would utilize a single lens between the multiplier phototube and the mirror (or prism) B to take the place of one lens in each tube. The mirror B is sequentially rotated and redirects the flux from each collector in turn to the multiplier phototube (MPT). A suggested measurement period of 2 seconds plus a transfer period of 1/2 second between measurements would permit a determination of "a" in about 15 seconds. Shorter periods, consistent with the capabilities of the recording system, could be employed. The upwelling irradiance collector and downwelling irradiance collector have their surfaces located in the same horizontal plane. This is accomplished by tilting their respective optical axes as shown in the drawing, Figure (2a). The tilt angle shown is about  $9^{\circ}$ . The center of the spherical irradiance collector is also placed in this same horizontal plane by tilting its arm downward. Enough tilt is given to permit mounting the diffuse sphere from the bottom rather than the side, since this will minimize the error in the determination of scalar irradiance. It is essential to keep the three axes from the mirror, A, in the same plane and the axis of rotation of mirror B, perpendicular to this plane.

Location of the pressure transducers is not shown and is not considered critical.

## Part II. Optical Components

Irradiance determination: In the measurement of the absorption coefficient "a" it is important that the optical integrations be accurately performed because the errors will not tend to cancel as they do (for example) in the determination of the diffuse attenuation function K. In determining the latter function one measures the downwelling irradiance at two depths,  $Z_1$  and  $Z_2$ . K is then determined from the equation:

$$\frac{H(Z_1)}{H(Z_2)} = e^{+K \Delta Z}$$

The same irradiance collector is, of course, used for both H measurements. If the plate is not a true cosine collector an error will be introduced into the value of  $H(Z_1)$ , which will depend on the radiance distribution as well as the properties of the collector plate. The value of  $H(Z_2)$  will also be in error for the same reason. However, if the radiance distribution is the same at  $Z_1$ , as it is at  $Z_2$ , the error in  $H(Z_1)$ , will cancel that in  $H(Z_2)$ . The error introduced into K will depend therefore on the difference in radiance distribution at the two depths which in practice can be kept small.

This situation does not obtain in the measurement of the absorption coefficient. From Equation (1) it can be seen that the determination of "a" is based on measurements of h,  $H(Z_+)$  and  $H(Z_-)$ . The radiance

distribution for the upper hemisphere which yields  $H(Z-)$  is drastically different from the radiance distributions for the lower hemisphere which yields  $H(Z+)$  and an imperfect cosine collector will weight these radiance distributions quite differently. In addition to this the quantities  $H(Z+)$  and  $H(Z-)$  are subtracted (rather than divided) so there is not the same opportunity for error cancellation. Finally, the difference  $H(Z+) - H(Z-)$  is divided by  $h$  which, if measured by an imperfect spherical collector, would more than likely contain a third type of weighting error.

An optical component which will perform the integration

$$\int_0^{\pi/2} N \cos \theta \, d\omega$$

can be made from 1/16" Rohm and Haas #7420 diffuse plastic, cemented to a clear plastic disc to provide mechanical strength, See Figure 3. The flux acceptance properties of a typical irradiance collector of this kind are not the same when the front surface is ground as when it is polished, nor are they the same in water as in air. An irradiance collector can be tested for directional acceptance by mounting it under water so as to rotate about a vertical axis through its front surface.

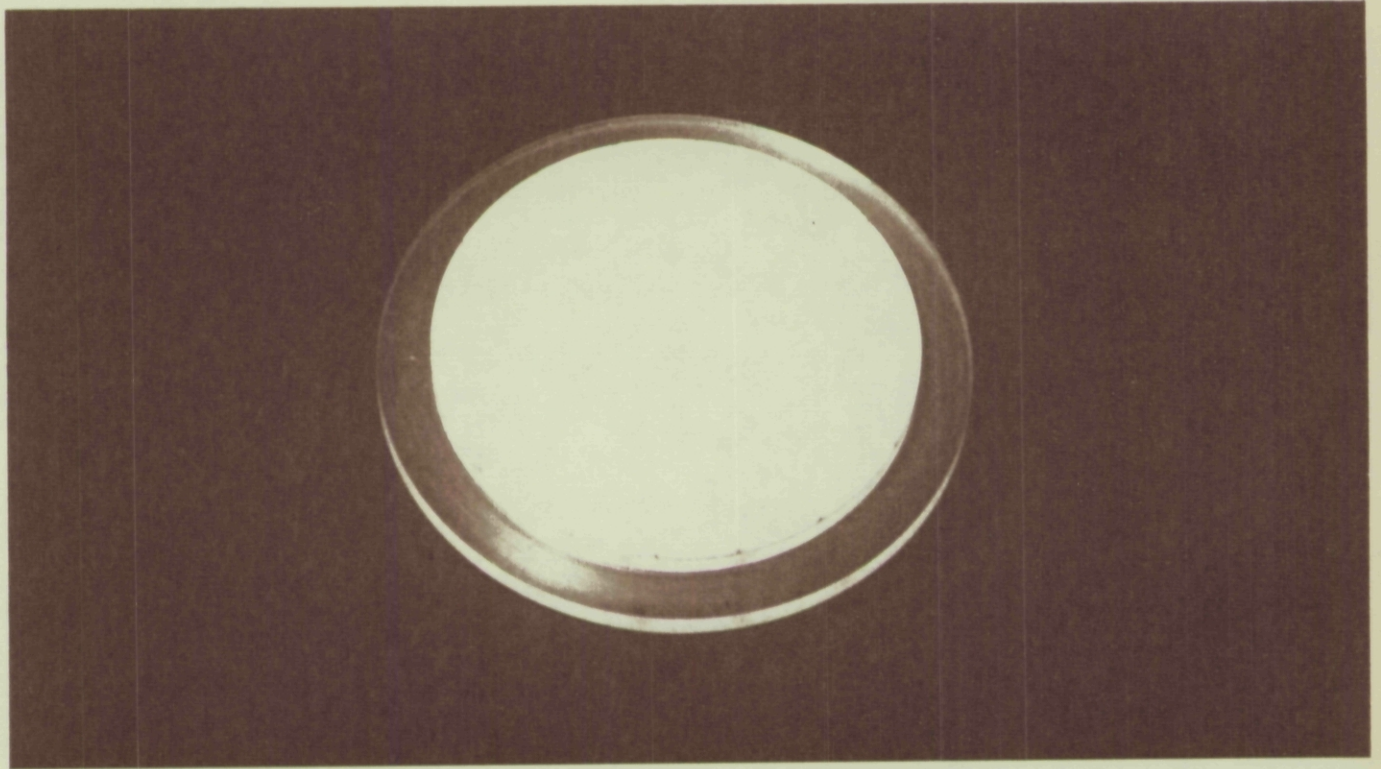

Figure 3

Irradiance collector made from 1/16" Rohm and Haas #7420  
diffusing plastic cemented to clear plastic backing. Outer sur-  
face is rough ground with 1F emery.

Collimated light from a lamp operated on regulated power is first directed perpendicular to the collector surface (  $\theta = 0$  ).

Relative data on the collecting properties of the surface at other angles is obtained by rotating the irradiance plate. The experimental set-up is shown in Figure (4). Experimental measurements for a typical plate are given in Table I.

The error resulting from the failure of the plate described in Table I to collect according to the cosine law has been found by integration using radiance distribution data from Tyler (1958)<sup>2</sup>, and is given in Table II.

In mounting a diffusing plate, the metal retaining ring acts like a flux sink and causes an annular shadow around the edge of the irradiance collector. This shadow has been found to be about .5 cm wide for the above plate. The effect of this edge has been studied by means of a special plate (Figure (5) ) fabricated in such a way that the whole surface is shadowed in the manner described. It appears that this optical effect results in a deterioration of the desirable integrating properties of the plate. An integration based on the underwater collection properties of the shadowed test plate and the radiance distribution at 53.7 m (Tyler 1958)<sup>2</sup> used before, yields an error of 9% in the determination of  $H(-)$  , (see Table II). For this reason, in designing irradiance plates the diameter of the diffusing plate should be made larger than the sensitive area of the photo-

---

(2) J. E. Tyler, Radiance Distribution as a Function of Depth in the Submarine Environment, SIO Ref. 58-25, 28 March 1958.

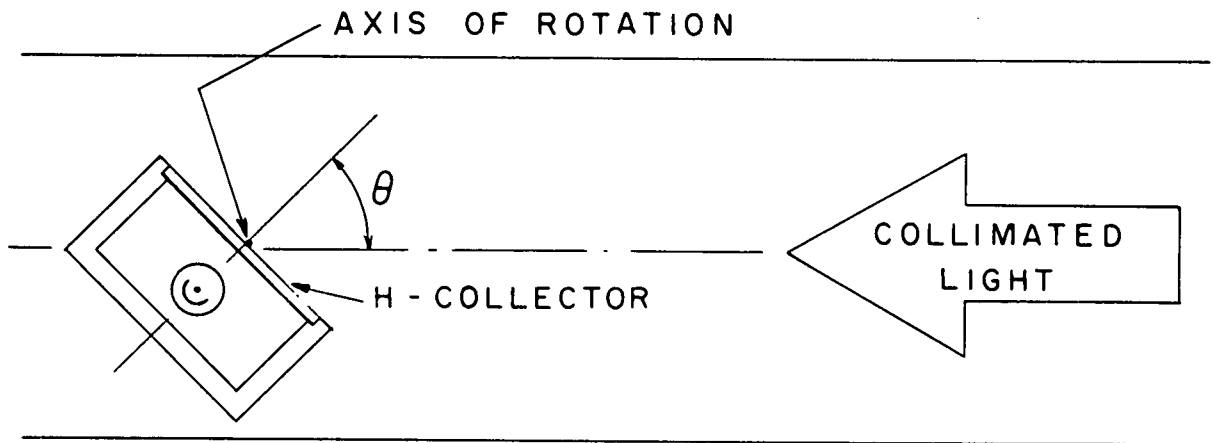

Figure 4 - Experimental set up for testing the performance of an irradiance collector.

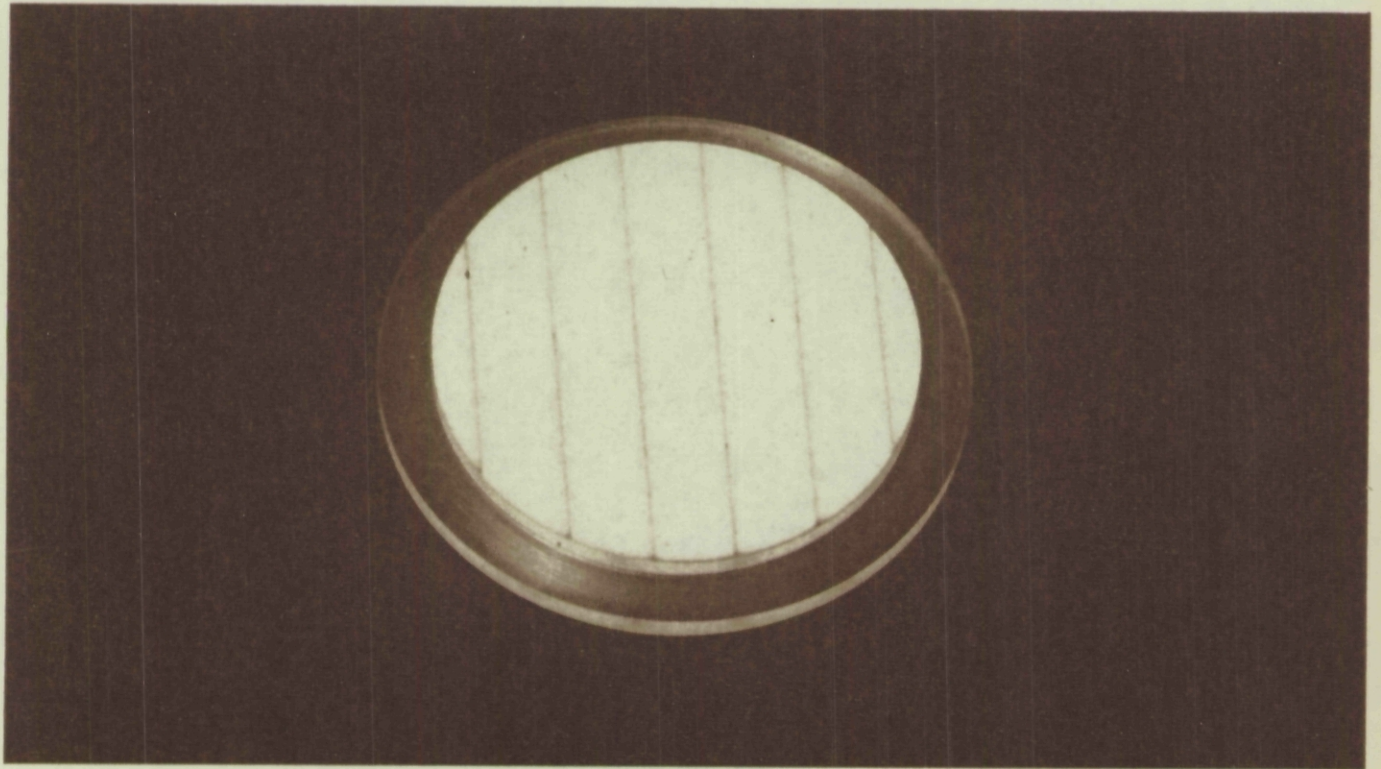

Figure 5

Shadowed collector made from 1 cm strips of Rohm and Haas  
#7420 diffusing plastic with edges painted black.

TABLE I

Acceptance characteristics of a laminated irradiance collector made from 1/16" Rohm and Haas #7420 diffusing plastic with its outer surface ground and mounted as shown in Figure 3.

$\theta$	$\cos \theta$	Collecting Functions
0	1.000	1.000
5	.996	.997
10	.985	.985
15	.966	.970
20	.940	.940
25	.906	.900
30	.866	.860
35	.819	.805
40	.766	.741
45	.707	.680
50	.643	.610
55	.574	.540
60	.500	.455
65	.423	.380
70	.342	.300
75	.259	.230
80	.174	.160
85	.087	.095
90	.000	.040

TABLE II

Computed Errors in Downwelling Irradiance Introduced by  
the Cosine Collector Described in Table I and by Shadowing

Depths	16.6 m	29.0 m	53.7 m
Surface-Ground plate in air			1.7% high
Surface-Ground plate in water	1.9% low	2.1% low	2.1% low
Unground plate in water			4.1% low
<hr/>			
Shadowed Surface-Ground plate in water	9.2% low	9.5% low	9.3% low

transducer, or an internal stop should be provided between the irradiance plate and the photo-transducer so that the shadow does not constitute a part of the surface which is being used for the measurement. Figure (6) is a sketch showing recommended design features of a mounted cosine collector plate for use in determining irradiance H.

The 1/16" diffuse plastic (unground) used for irradiance collectors in this work has been subjected to aging tests over a period of four years by mounting a sample on the roof. The sample was tilted  $45^\circ$  to the horizontal and faced south for maximum sun exposure. Transmittance curves for the original plastic, after one and one half month exposure, after five months exposure, and after four years and five months exposure are shown in Figure (7). The sample has yellowed significantly but throughout most of the visible region of the spectrum has become slightly more transmitting. Any initial calibrations dependent on the transmittance of this diffuser would have changed somewhat with exposure time depending on the band width of the transmitted light. It may be possible to obtain improved diffusing plastic which is more stable under exposure - or to pre-expose the diffusing plastic, since a large part of the change apparently takes place during the early stages of exposure.

#### Scalar Irradiance Determination:

A translucent sphere whose surface is a cosine collector at every point will collect in proportion to a quantity called spherical irradiance.

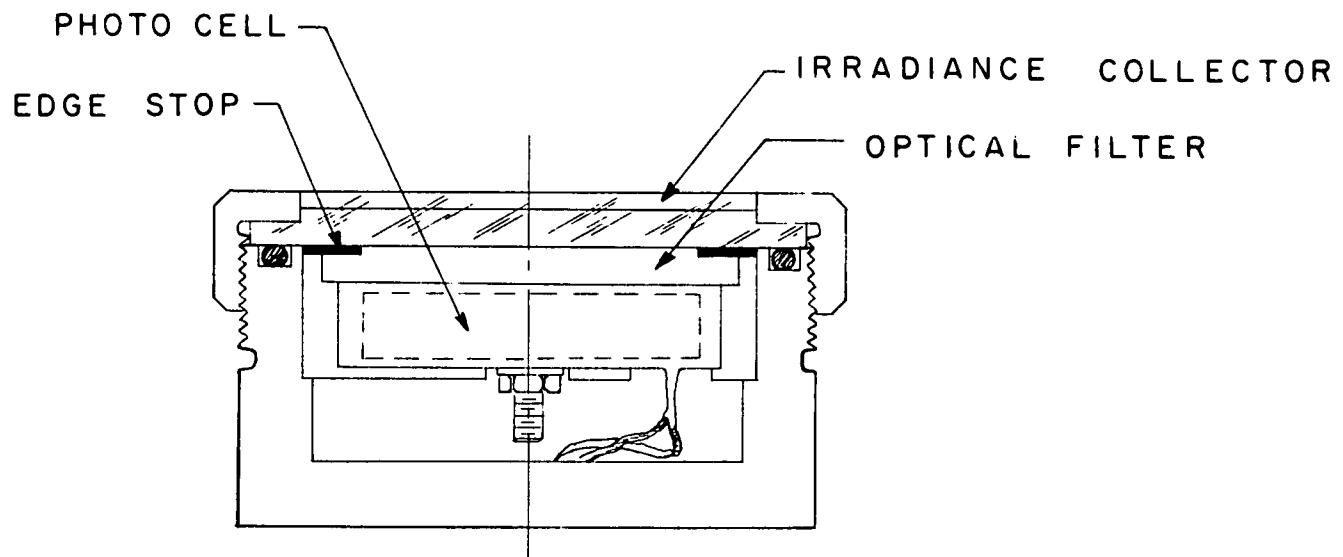

Figure 6. Recommended Optical Design Features of a Mounted Irradiance Collector.

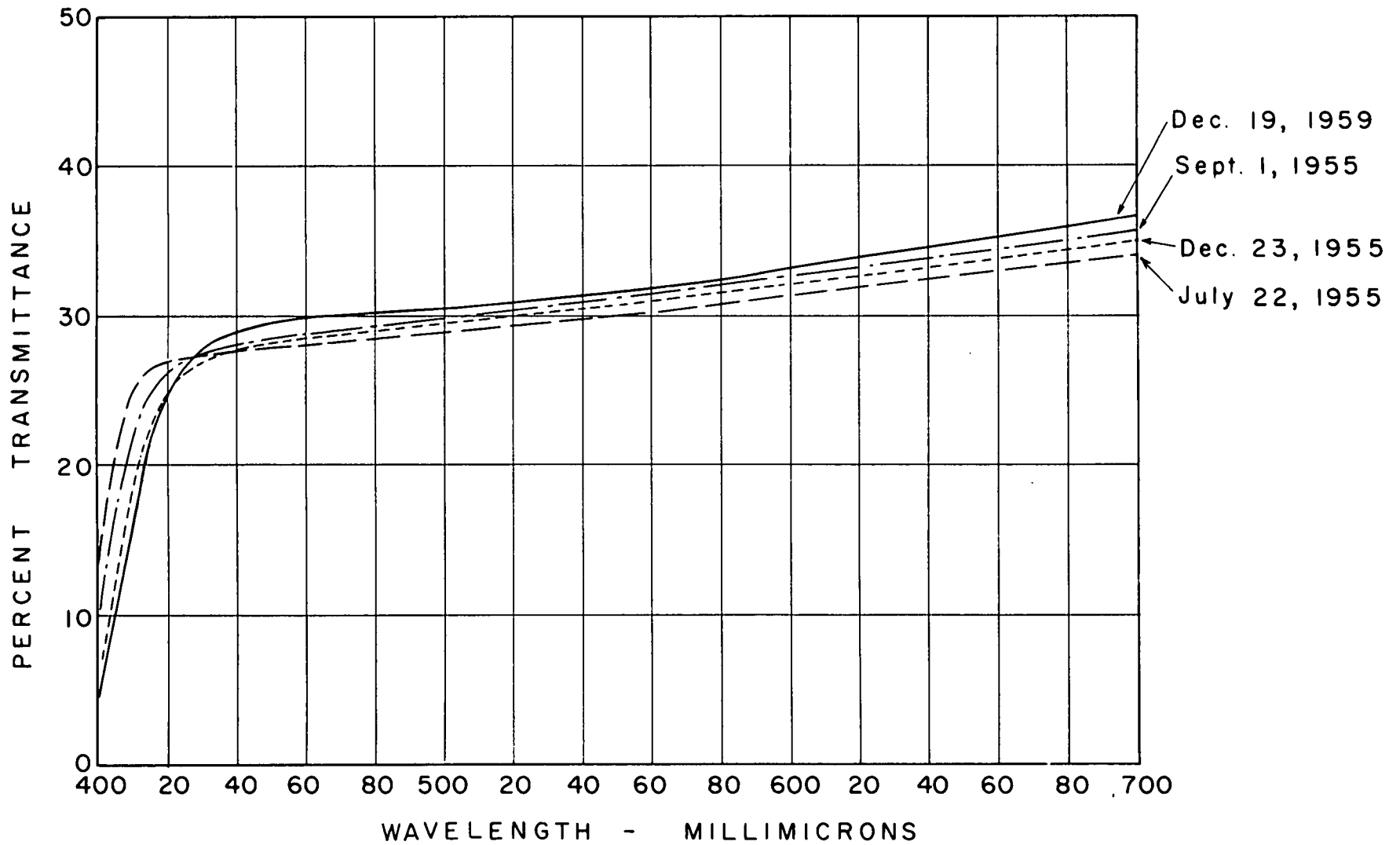

Figure 7 - Changes in transmittance properties of diffusing plastic on exposure to sun and weather.

Spherical irradiance  $h_{4\pi}$  is related to scalar irradiance  $h$  by the equation:

$$h_{4\pi} = \frac{1}{4} h \quad (1)$$

A translucent sphere can thus be used to make the measurement of  $h$  required by theory.

A technique for making diffuse spheres has been developed by R. W. Austin. In this method diffuse white plastic is hot pressed into a 6" hemispherical mould. The hemispheres are then machined and joined with plastic cement.

Spheres for the measurement of spherical irradiance can be performance tested by mounting them under water so that they can be rotated about their centers (see Figure (8) ). The sphere is then uniformly flooded with collimated light using a regulated power supply for the light source. The directional acceptance of a typical sphere is given in Table III. In this table the collector is assumed to be mounted with the phototube housing at the nadir. The measurement at  $\theta=0^\circ$  was obtained with the collimated light coming from the zenith. Measurements were made from  $\theta=0^\circ$  to  $180^\circ$  and from  $\phi=0^\circ$  to  $180^\circ$  when  $\theta$  was  $90^\circ$ . The remainder of the table has been interpolated.

When these acceptance values are used together with the radiance distribution data of Tyler (1958)<sup>2</sup>, to determine  $h$  by integration, this collector is found to give a result that is 11% to 13% low.

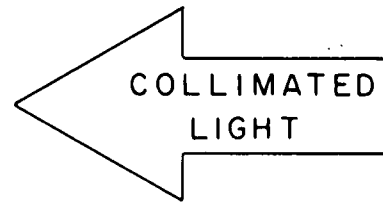
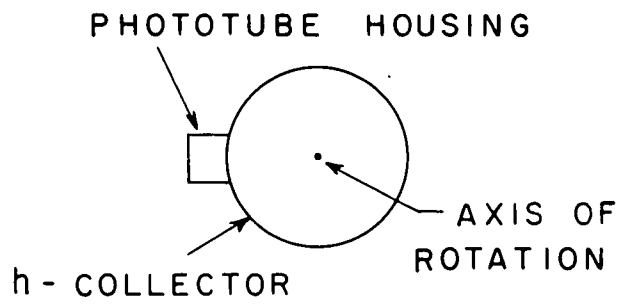

---

(a)

ZENITH - NADIR SCAN

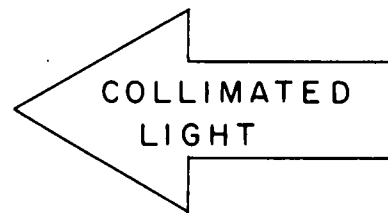
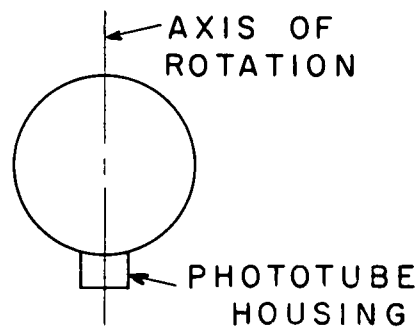

---

(b)

AZIMUTH SCAN

Figure 8 - Experimental set-up for testing the performance of h-collectors.

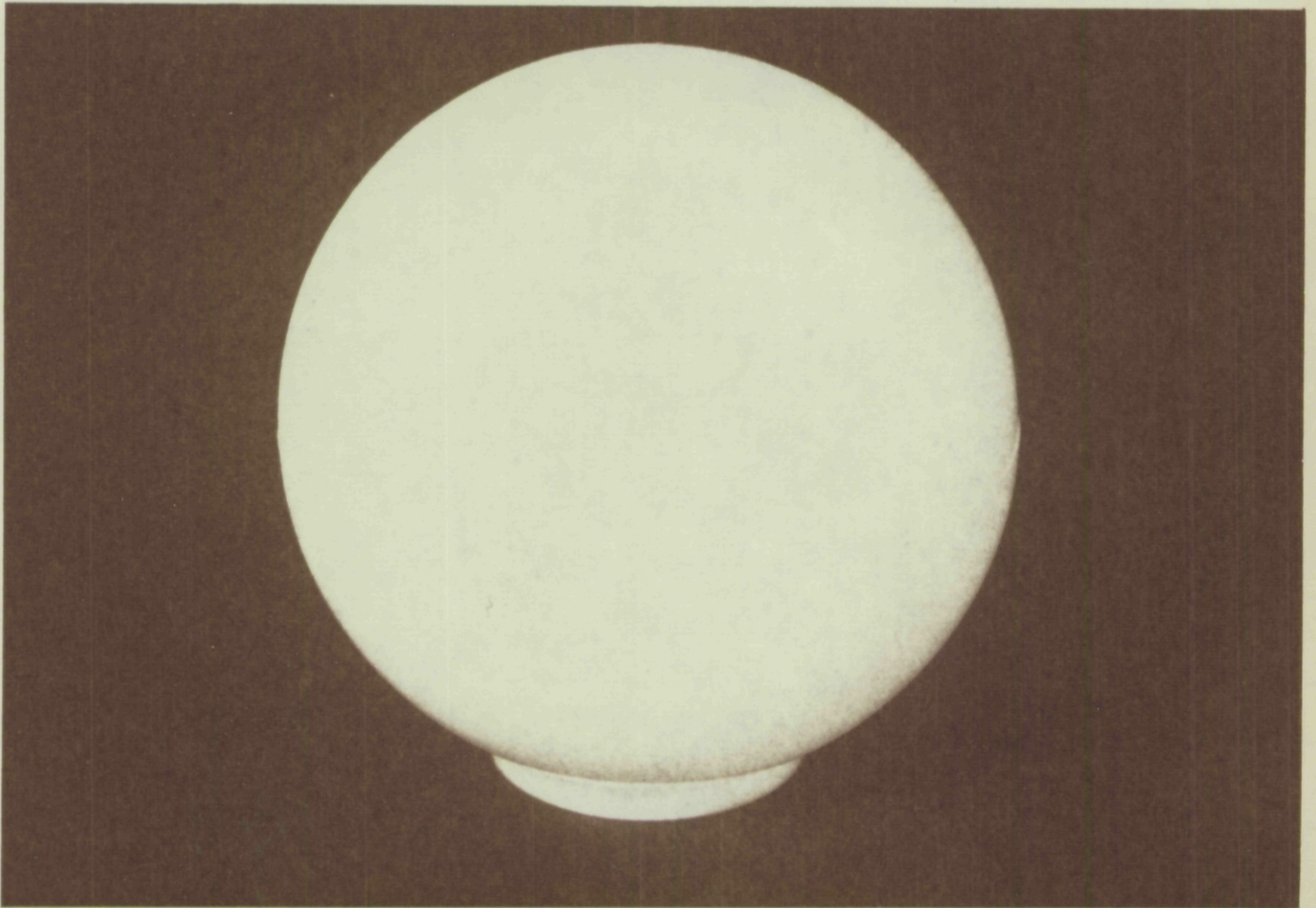

Figure 9

Spherical collector for determining spherical irradiance

Although this collector is perfectly satisfactory for the determination of  $K$ , it should be further developed before being applied to the more critical job of determining the absorption coefficient "a". The collecting properties of this sphere might easily be improved by perfecting the pressing technique to yield uniform wall thickness and by reducing the size of the metal connecting ring or phototube housing.

A spherical collector incorporates an inherent inaccuracy because its top and bottom are at different depths. Some compromise must be reached on the size of sphere to be selected for this measurement:

From experiment it is known that

$$\frac{h(z_1)}{h(z_2)} = e^{K \Delta z} \quad (2)$$

Thus

$$\frac{h(z_1) - h(z_2)}{h(z_2)} = e^{K \Delta z} - 1 \quad (3)$$

Using the diameter of the sphere for  $\Delta z$ , the upper limit of the error from this source can be estimated. Thus using Tyler's (1958)<sup>3</sup> data ( $K = .164/m$ ), the error in a 6" (0.15m) diameter sphere would

be indicated by

$$\frac{h(z_1) - h(z_2)}{h(z_2)} = 0.164 \times 10^{-1}$$

or the upper limit of the error would be 2.5%.

## Part II. Probe.

A probe for measuring the absorption coefficient of ocean water should if possible fulfill two important criteria:

(1) It should contain as few phototubes as possible since this will result in greater simplicity in all respects. As the number of phototubes increases the electronic circuitry becomes complex, the mechanical design becomes complex, and the optical requirements become complex. Three phototubes mean three optical filters for each wave length, or three filter wheels, if wave length selection is to be remotely controlled. Since phototube-filter combinations seldom match, the problem of intercalibration would be greatly increased. The increased circuit complexity as the number of phototubes goes up is equally obvious.

(2) The time resolution of the data recording procedure should be short enough to substantially free the data from changes in the ambient natural lighting and from changes in the composition of the water at a

particular station under study. If this requirement can be met, it will have the additional advantage of eliminating the need for a "deck" cell.

### Part III

Data Recording: The ambient light level under which this instrument must operate is controlled by the time of day, the state of the sky, and the depth of the instrument. The useful depth range of the instrument under a given set of lighting conditions will be limited by the signal-to-noise ratio of the photo-transducer.

Under typical sunny-day lighting conditions the values of  $H(Z+)$ ,  $H(Z-)$ , and  $h(z)$  will be in approximately the following ratio:

1.  $H(Z+)$
44.  $H(Z-)$
60.  $h(z)$

And, of course, the signals received by the phototube will be in the same ratio if the instrument is in correct adjustment. In the useful depth region of this instrument no great variation would be expected in these ratios. In order to determine the absorption coefficient at any depth where flux is not the limiting factor, the instrument should incorporate features which will:

- (1) Result in maximum signal-noise ratio.
- (2) Make sequential light measurements which can be expected to vary from each other by a factor of about 100 to 1.

(3) Provide stable gain adjustment which will permit operation over a very large range of ambient light levels, that is, from nearly full sunlight to an ambient light level which produces a signal to noise ratio of about 1.

(4) Provide simultaneous determination of depth by means of a pressure transducer.

(5) Provide means for automatically recording the four variables,  $H(z+)$ ,  $H(z-)$ ,  $K(z)$ , and  $Z$ .

The method of recording the data should conform to the data reduction procedure which will be used. Ink recordings on strip chart paper require visual readout followed by digital computations. Recordings on magnetic or punched tape can be incorporated directly into a computer program.

### Calibration

One procedure for the calibration of this instrument would be to expose its three optical integrators one after the other to a regulated source of collimated light using an angle of incidence of 0 degrees on the  $H$  collectors. The independent flux control diaphragms would be adjusted to make the three readings equal. This procedure is based on the definitions of  $H$  and  $K$  as follows:

By definitions:

$$H = \int N \cos \theta \, d\omega$$

$$K = \int N \, d\omega$$

If  $N$  is made equal to 0 at all angles except  $\theta = 0$ , then  $N \cos \theta = N$  and for this flux field and:

$$H = \int N d\omega = h$$

An alternative (or additional) calibration could be made by placing the optical integrators inside a diffuse sphere the walls of which exhibited constant  $N$  for all values of  $\theta$ . Under the circumstances:

$$\begin{array}{ll}
 H = N \int \cos \theta d\omega & h = N \int d\omega \\
 \text{or } H = 2\pi N \int \cos \theta \sin \theta d\theta & h = 2\pi N \int \sin \theta d\theta \\
 = 2\pi N \left( \frac{1}{2} \sin^2 \theta \right) \Big|_0^{\pi/2} & = 2\pi N (-\cos \theta) \Big|_0^{\pi/2} \\
 = 2\pi N \left( \frac{1}{2} - 0 \right) & = 2\pi N (-0 + 1) \\
 = \pi N & = 2\pi N
 \end{array}$$

Therefore: 
$$\frac{h}{H} = 2$$

Sources of Operational Error:

In use, this instrument should not be particularly sensitive to departures from horizontal orientation providing the orientation does not change between two depths which are being used for the determination of "a". This is because it is the net change of irradiance with depth that determines "a" and not the irradiances per se. If exceptionally

strong currents are to be encountered a balanced-torque mounting arrangement could be employed that would tend to keep the instrument horizontally oriented even though the supporting cable would show a high wire angle.

Since the determination of "a" requires that readings be taken with this probe as a function of depth, measurements at a junction of two strata will be difficult because of the possibility of selective attenuation at only one collector for example. Measurements in vertically stratified water or "cloudy" water where the cloud detail is about equal to the dimensions of the instrument or the depth differential (if only two depths are used) will suffer similarly.

For near-surface measurements, the shadow of the supporting or electric cable may fall on one of the collectors and lead to an incorrect determination of the absorption coefficient. This and errors of a similar nature can be detected and eliminated by providing a hydrovane that will twist the cable as the instrument is lowered. When the instrument is held at constant depth the twist will unwind and the recorded values will reveal the influence of perturbation from wire shadows.

The presence of the opaque metal housing of the instrument will perturb the light field. For black objects the error from this source can be estimated by the use of Tables IV to IX inclusive in the appendix.

These Tables are based on the radiance distribution measurements of Tyler (1958)<sup>2</sup>, and the integration techniques described in Tyler, Richardson and Holmes (1959)<sup>3</sup>, and Tabulate for  $H$  and  $h$  the weighted values of radiance in the directions specified by  $\theta$  (the tilt angle from the zenith) and  $\phi$  (the azimuth angle from the sun). The sum of the entries is given for each table and represents a correct normalized value of  $H$ , or  $h$ . (Tables IV to IX give correct relative values of  $H$  and  $h$ ). To estimate the error due to a black object, the angular coordinates of its position are located in the table and its angular subtense is estimated and plotted in the table. The table is then summed leaving out the values affected by the black object. This new sum is subtracted from the full sum and the difference is divided by this full sum to obtain the error. Errors obtained in this way will tend to be too large because the method does not account for the space light which exists between the black objects and the collector. An estimate of this type shows that the phototube housing in Figure (1) or (2a) by its presence will cause a .5% error in the determination of upwelling irradiance. Similar estimates of perturbation in the value of  $H$  can be made from Tables IV, V, VI, and in the value of  $h$  from Tables VII, VIII, and IX.

The mutual perturbation caused by the  $H$ -collectors can be estimated in the same way, but the perturbation caused by the  $h$ -collector

---

(3) Method for obtaining the optical properties of Large Bodies of Water Journal of Geophysical Research, Vol. 64 #6, pg 667, June (1959).

is more difficult because it is not black. It may be easier to make experimental tests of this effect and alter the length of its supporting arms until the error is reduced to an acceptable figure.

## Discussion:

Equation (7) is based on the assumption that the distribution of radiance around a point in the medium is independent of the horizontal position of the point in the medium.

As a consequence, the equations developed in the theory section can only under very special circumstances be used for measurements made with artificial light nor can they be used if bioluminescent organisms are sufficiently numerous to invalidate the assumption.

The determination of the volume absorption coefficient by means of any of the equations in the Theory section depends on measurements of the irradiance and scalar irradiance produced by natural light at various depths in a homogeneous or horizontally stratified hydrosol.

From observations of various kinds in lake and ocean water it is believed that the conditions specified by this assumption will be found at many sites and that an instrument based on equation (7) or one of its derivatives will therefore be a useful device for obtaining the volume absorption coefficient of the water at that site.

Examination of equations (7) through (18) reveals that the determination of the absorption coefficient depends on the measurement of four parameters:

(1) Upwelling irradiance  $H(z+) = \int_{\frac{\pi}{2}}^{\pi} N \cos \theta \, d\omega$  (4)

$$(2) \text{ Downwelling irradiance } H(z-) = \int_0^{\frac{\pi}{2}} N \cos \theta d\omega \quad (5)$$

$$(3) \text{ Scalar irradiance } h = \int_{4\pi} N d\omega \quad (6)$$

$$(4) \text{ Depth } z$$

Techniques have already been discussed for making optical components which will perform the integrations shown in (4), (5) and (6) above, and for presenting the result in useable form to a photo-transducer. However, no methods are known for optically performing the mathematics called for by equations (7) through (18). These manipulations must therefore be accomplished at some point after the photoelectric coupling.

The various equations in the following section suggest a variety of ways of electrically utilizing and combining the four essential parameters.

#### Theory:

A theoretical basis for the determination of the volume absorption coefficient of horizontally stratified water has been derived by Preisendorfer (1957)<sup>4</sup> and is as follows:

$$a(z) = \frac{1}{h(z)} \times \frac{d\bar{H}(z+)}{dz} \quad (7)$$

(4) R. W. Preisendorfer, "The Divergence of the Light Field in Optical Media", SIO Ref. 58-41, 26 July 1957.

where

$$\begin{aligned} h(z) &= h_+(z+) + h_-(z-) \\ H(z+) &= H(z+) - H(z-) \end{aligned}$$

### Section A

Equation (7) can be expanded to give:

$$a(z) = \frac{1}{h(z)} \left[ \frac{dH(z+)}{dz} - \frac{dH(z-)}{dz} \right] \quad (8)$$

From the definition of the  $K(z \pm)$  functions:

$$\begin{aligned} \frac{dH(z+)}{dz} &= -H(z+)K(z+) \\ \frac{dH(z-)}{dz} &= -H(z-)K(z-) \end{aligned}$$

Substituting these in equation (8) gives:

$$a(z) = \frac{1}{h(z)} \left[ -H(z+)K(z+) + H(z-)K(z-) \right] \quad (9)$$

In deep water it is known from experimentation that  $K(z+)$  is very nearly equal to  $K(z-)$ . In situations where this equality can be accepted as fact, equation (9) can be simplified to give:

$$a(z) = \frac{K(z \pm)}{h(z)} \left[ H(z-) - H(z+) \right] \quad (10)$$

SECTION B

Another form of equation (7) can be developed from equation (9) if the conditions of measurement are such that  $K(z-)$  can be taken as equal to  $K(z+)$ . Thus:

$$K(z+) = K(z-) = \bar{K}(z)$$

where  $\bar{K}(z)$  is the attenuation function for  $\bar{H}(z+)$ , that is

$$\frac{d\bar{H}(z+)}{dz} = -\bar{H}(z+) \bar{K}(z) \quad (11)$$

and equation (7) becomes:

$$a(z) = - \frac{\bar{H}(z+) \bar{K}(z)}{h(z)} \quad (12)$$

SECTION C

From the definitions of  $K(z+)$  and  $K(z-)$

$$H(z+) = H(0+) e^{-K(z+)z}$$

$$H(z-) = H(0-) e^{-K(z-)z}$$

Again using the assumption that  $K(z+) = K(z-) = \bar{K}(z)$

$$H(z+) - H(z-) = \left[ H(0+) - H(0-) \right] e^{-\bar{K}(z)z}$$

or

$$\bar{H}(z+) = \bar{H}(0+) e^{-\bar{K}(z)z}$$

The quantity  $\bar{H}(0+)$  would be impractical to measure due to wave motion at the surface and the consequent high noise level. This quantity can be eliminated from the equation as follows:

$$\bar{H}(z_1+) = \bar{H}(0+) e^{-\bar{K}(z)z_1} \quad (13)$$

$$\bar{H}(z_2+) = \bar{H}(0+) e^{-\bar{K}(z)z_2} \quad (14)$$

Dividing equation (13) by equation (14) gives:

$$\frac{\bar{H}(z_1+)}{\bar{H}(z_2+)} = e^{-\bar{K}(z)z_1 + \bar{K}(z)z_2}$$

$$= e^{\bar{K}(z)\Delta z}$$

or

$$\ln \frac{\bar{H}(z_1+)}{\bar{H}(z_2+)} = \bar{K}(z)\Delta z \quad (15)$$

Substituting equations (11) and (15) into equation (7) gives the following form. This same equation appears as equation (8) in Tyler, Richardson, and Holmes, (1959)<sup>3</sup> :

$$a(z) = \frac{-\bar{H}(z+) \ln \frac{\bar{H}(z,+)}{\bar{H}(z,+)}}{k(z) \Delta z} \quad (16)$$

#### SECTION D

Preisendorfer and Richardson<sup>5</sup> give two additional equations based on the assumption that

$$K(z+) = K(z-) = k_{\infty}$$

where  $k_{\infty}$  is the logarithmic derivative of either  $H(z)$  or  $\bar{h}(z)$  and is a constant characteristic of the water at asymptotic depth. These equations are:

$$a = k_{\infty} \frac{\bar{H}(z-)}{k(z)} \quad (17)$$

$$a = k_{\infty} \frac{1 - R_{\infty}}{D(-) + R_{\infty} D(+)} \quad (18)$$

---

(3) J. E. Tyler, W. H. Richardson and R. W. Holmes; Method for Obtaining the Optical Properties of Large Bodies of Water, Journ. of Geophysical Research, Vol.64, June 1959, pp 667-673.

(5) R. W. Preisendorfer and W.H. Richardson: Simple Formulas for the Volume Absorption Coefficient in Asymptotic Light Fields, SIO Ref. 58-79, 21 November 1958.

Definition of Symbols:

$a(z)$	volume absorption coefficient at depth $z$
$h(z)$	total scalar irradiance at depth $z$
$d\bar{H}(z+)$	net upwelling irradiance at depth $z$
$z$	depth $z$
$h(z+)$	upwelling scalar irradiance
$h(z-)$	downwelling scalar irradiance
$H(z+)$	upwelling irradiance
$H(z-)$	downwelling irradiance
$K(z+)$	attenuation functions for upwelling flux
$K(z-)$	" " " downwelling flux
$\bar{K}(z)$	" " " net upwelling flux
$k_{\infty}$	" " " asymptotic irradiance distribution
$R_{\infty}$	reflection function for asymptotic radiance distribution
$\bar{H}(z-)$	net downwelling irradiance
$D(+)$	distribution function for upwelling flux
$D(-)$	distribution function for downwelling flux

## APPENDIX



TABLE FOR ESTIMATING ERRORS IN IRRADIANCE DUE TO PERTURBATION OF THE LIGHT FIELD AT DEPTH 16.6 METERS

TABLE IV

$\theta$	0°	20°	40°	60°	80°	100°	120°	140°	160°	180°	SUM
0°	57.09	57.09	57.09	57.09	57.09	57.09	57.09	57.09	57.09	57.09	1,027.62
10°	1300.39	1192.92	1000.55	796.35	643.75	523.38	440.63	392.27	365.40	356.80	12,367.69
20°	6852.65	3582.96	2134.11	1399.90	967.20	722.47	569.75	477.73	428.78	415.07	27,833.52
30°	10,155.92	4458.05	2273.87	1398.09	957.56	704.32	538.13	440.53	385.13	364.03	32,831.31
40°	2,645.74	2,276.77	1604.84	1070.89	734.93	536.95	407.96	308.97	281.37	263.37	17,354.47
50°	1,358.86	1,229.88	950.90	650.93	446.96	332.97	256.47	205.78	176.38	164.68	10,024.08
60°	643.65	593.53	458.99	329.74	238.20	183.33	145.08	121.08	104.46	96.81	5,089.28
70°	242.78	219.28	178.17	141.56	111.01	88.50	67.74	59.52	52.28	49.53	2,128.43
80°	72.54	68.35	59.00	48.47	39.12	32.13	26.87	22.89	20.10	18.81	725.21
90°	4.03	3.75	3.27	2.96	2.33	1.96	1.65	1.43	1.30	1.24	42.57
											<u>109,424.18</u>
90°	4.033	3.755	3.267	2,958	2.331	1.962	1.653	1.434	1.304	1.245	42.606
100°	25.362	24.503	22.246	19.345	16.550	14.294	12.681	11.499	10.640	10.360	299.238
110°	29.760	28.781	26.432	23.691	21.341	19.227	17.445	16.290	15.585	15.232	382.578
120°	26.643	26.247	24.955	23.319	21.525	19.995	18.755	18.043	17.568	17.305	384.762
130°	22.198	21.958	21.508	20.548	19.738	18.988	18.178	17.518	17.158	16.918	350.304
140°	17.848	17.608	17.428	16.978	16.498	16.078	15.659	15.358	15.298	15.298	294.954
150°	13.242	13.163	13.110	13.058	12.820	12.662	12.451	12.266	12.187	12.187	228.863
160°	8.830	8.830	8.830	8.811	8.752	8.673	8.595	8.497	8.478	8.478	156.240
170°	4.535	4.535	4.535	4.535	4.535	4.535	4.535	4.535	4.535	4.535	81.630
180°	0.404	0.404	0.404	0.404	0.404	0.404	0.404	0.404	0.404	0.404	7.272
											<u>2,228.445</u>









