

Visibility Laboratory
University of California
Scripps Institution of Oceanography
San Diego 52, California

ATMOSPHERIC OPTICAL MEASUREMENTS DURING
HIGH ALTITUDE BALLOON FLIGHT, PART II, SKY LUMINANCES

Almerian R. Boileau

July 1961

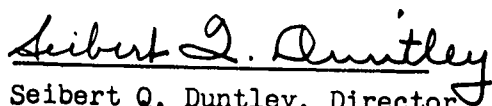
Bureau of Ships
Contract NObs-72092

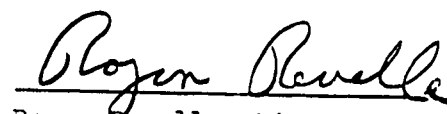
SIO REFERENCE 61-1

Project S FO01 05 01

Approved:

Approved for Distribution:


Seibert Q. Duntley, Director
Visibility Laboratory


Roger Revelle, Director
Scripps Institution of Oceanography

CONTENTS

	<u>Page</u>
1. INTRODUCTION AND SUMMARY	1
2. PROCEDURE	3
2.1 Introduction	3
2.2 Purpose of Flight	3
2.3 Data Gathering	5
2.3.1 Recording Schedule	5
2.3.2 Weather	8
2.3.3 Position of Sun	8
3. INSTRUMENTATION	10
3.1 Sky Scanning Telephotometers	10
3.1.1 Location	10
3.1.2 Schematic	10
3.1.3 Light Level Range	10
3.1.4 Filters	12
3.1.5 Scanning Pattern	12
4. DATA TREATMENT	14
4.1 Data Recording	14
4.2 Data Reduction	14
5. PRESENTATION OF DATA	15
5.1 Notation	15
5.2 Organization of Data	15
6. INDEX OF GRAPHS	18
6.1 First Set - Descent from 0647 to 0813	18
6.2 Second Set - Descent from 0907 to 1033	19
7. REFERENCES	96
8. ACKNOWLEDGEMENTS	96

ILLUSTRATIONS

	<u>Page</u>
Balloon Tracks, Fig. 1	4
Temperature Profile, Fig. 2	6
Azimuth and Zenith Angle of Sun, Fig. 3	9
Sky Scanning Telephotometer, Fig. 4	11
Filter - Phototube Sensitivities, Fig. 5	13
Lines Used for Luminance Plots, Fig. 6	17
Sky Luminance vs Altitude, Fig. 7, <u>et seq.</u>	20
Sky Luminance vs Altitude, Fig. 25, <u>et seq.</u>	58

Atmospheric Optical Measurements During
High Altitude Balloon Flight, Part II, Sky Luminances*

by

Almerian R. Boileau

1. INTRODUCTION AND SUMMARY

Certain optical measurements of the atmosphere were made by the Visibility Laboratory of the University of California, San Diego, 21 June 1958, over central Minnesota. Data were recorded from daybreak to midmorning during the time four balloons carrying optical instrumentation from the Geophysics Research Directorate, Air Force Research Division, Bedford, Massachusetts, were floating at a higher altitude.

Part I of the report¹ presented the recorded optical measurements, with the exception of sky luminance and radiance distributions, as they varied with altitude, time of day, azimuth with respect to the sun, and meteorological conditions.

This part of the report, Part II, presents the sky luminance distribution as it varied with altitude, zenith angle, and azimuth with respect to the sun. Parts III and IV will present in a similar manner

* This report is a result of research which has been supported by the Geophysics Research Directorate, Air Force Research Division, Bedford, Massachusetts, and the U.S. Navy Bureau of Ships.

1. Almerian R. Boileau, "Atmospheric Optical Measurements During High Altitude Balloon Flight, Part I." SIO Reference 59-32-(1), Scripps Institution of Oceanography, University of California, La Jolla Campus, December 1959.

the sky radiance distributions as measured by filter-phototube combinations sensitive to the radiant energy at the short wavelength and long wavelength parts of the visible spectrum.

2. PROCEDURE

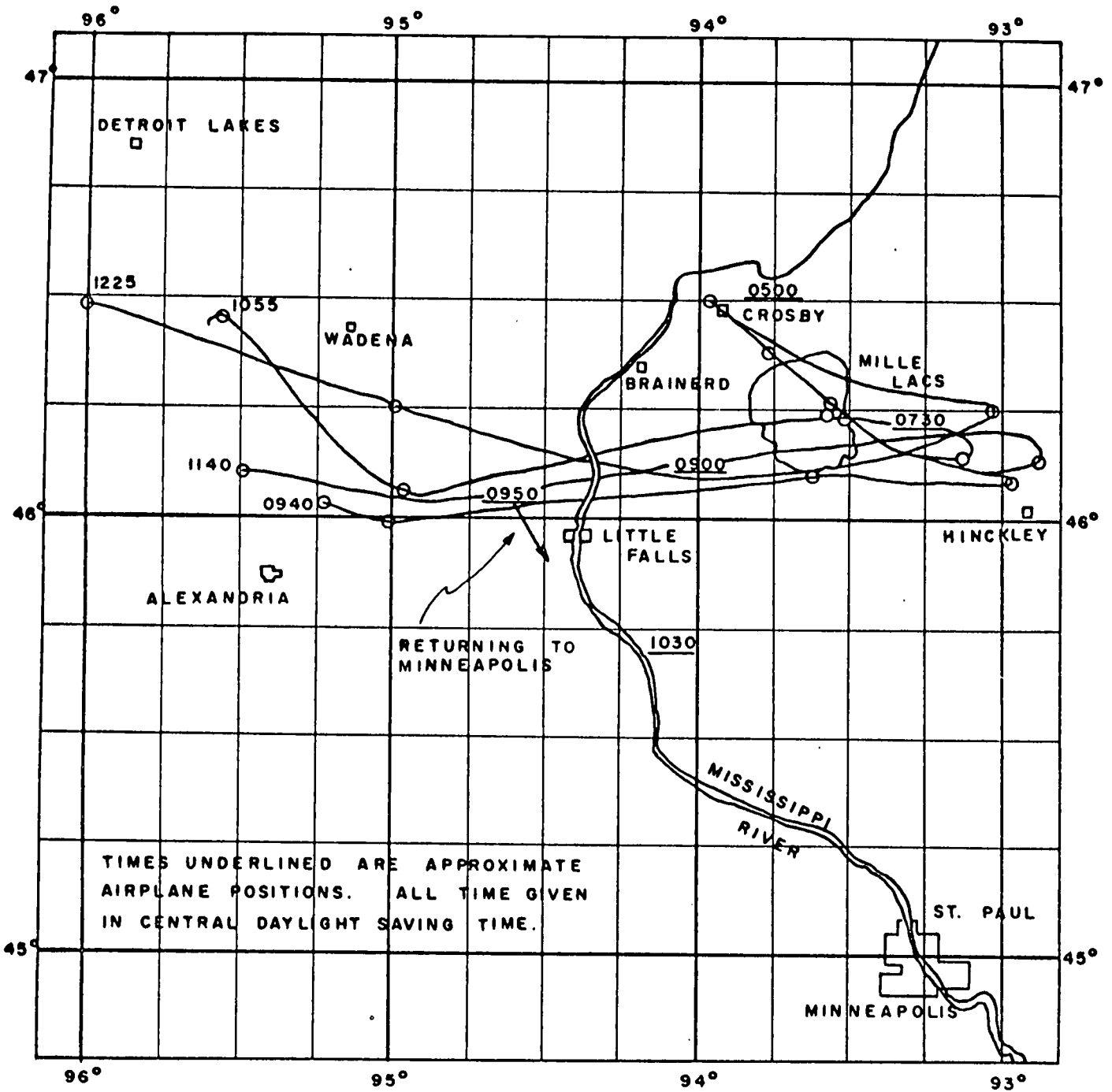
2.1 Introduction

U.S. Air Force XB-29 No. 4224725 took off for Flight 120 from the Air Force Base at Wold-Chamberlain Airport serving the Minneapolis-St. Paul area at 0415 21 June 1958 and proceeded to Crosby, Minnesota. The airplane carried optical and meteorological instruments from the Visibility Laboratory of the University of California, San Diego. Two of these instruments were sky scanning telephotometers by means of which the sky luminance and radiance distributions were to be measured. When the airplane arrived above Crosby, before sunrise, it was at an altitude of 20 000 feet.

2.2 Purpose of Flight

The flight was being made in the vicinity of Crosby to permit atmospheric optical measurements to be made by air borne Visibility Laboratory equipments at the same time that similar measurements were being made by balloon borne equipment. The balloons, four in number, were to be launched by Winzen Research, Inc., under the direction of Dr. V. J. Stakutis of the Thermal Radiation Laboratory, Geophysics Research Directorate, Air Force Research Division, Bedford, Massachusetts. The launchings proceeded on schedule, the balloons being launched, as observed from the XB-29, at 0500, 0521, 0536, and 0551.

These times and all times given subsequently in this report are Central Daylight Saving Time.



Balloon tracks are shown in solid lines. The time of release of each instrumented package from the balloon which carried it is indicated by the time at the end of each track. The underlined times are approximate airplane positions.

FIGURE 1
FLIGHT 120
JUNE 21, 1958
CENTRAL MINNESOTA

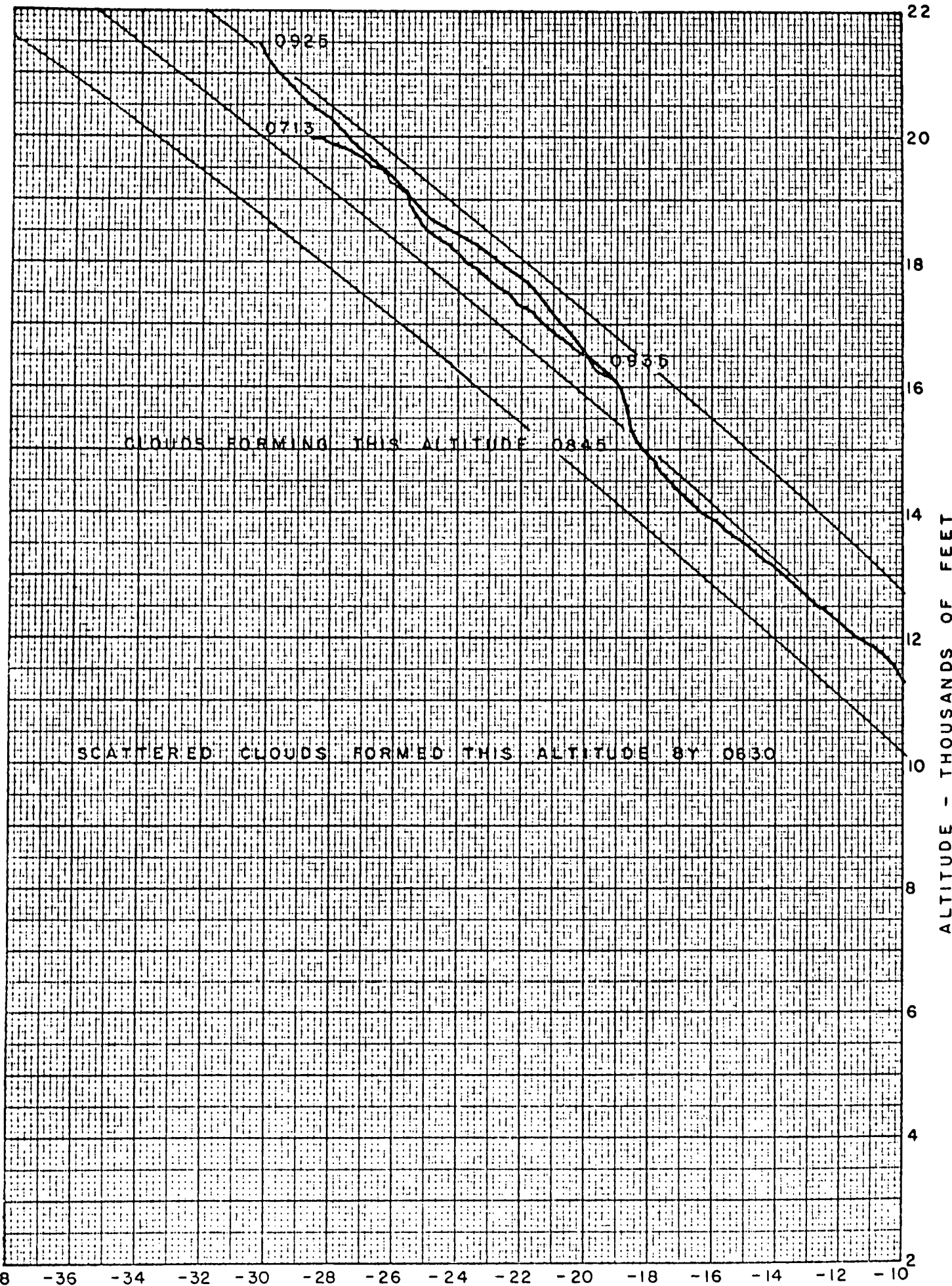
2.3 Data Gathering

The data-gathering operation was started as soon as there was enough light to cause all of the optical measuring instruments to respond. The XB-29 remained at altitude and in the general vicinity of the balloons until the start of the data-gathering runs at which time it became necessary to fly the airplane on prescribed courses and at different altitudes. At the conclusion of a data-gathering run the pilot returned to the vicinity of the balloons before starting another run. The balloons first drifted southeast until they were over the south shore of Mille Lacs Lake, then westward. The balloon tracks are shown in Fig. 1. The approximate positions of the XB-29 are also shown in Fig. 1 by the underlined times.

At the start of the data-gathering runs the lower scanning telephotometer became inoperative with the result that no lower sky distributions were recorded.

2.3.1 Recording Schedule. The upper sky luminance and radiance distribution data were recorded as follows:

<u>Central Daylight Saving Time</u>	<u>Altitude</u>
0635-0655	21 000 feet
0738-0751	11 000 feet
0813-0819	2 000 feet
0907-0915	22 000 feet
0938-0940	16 500 feet
0942-0945	17 200 feet
1033-1037	2 000 feet en route Minneapolis



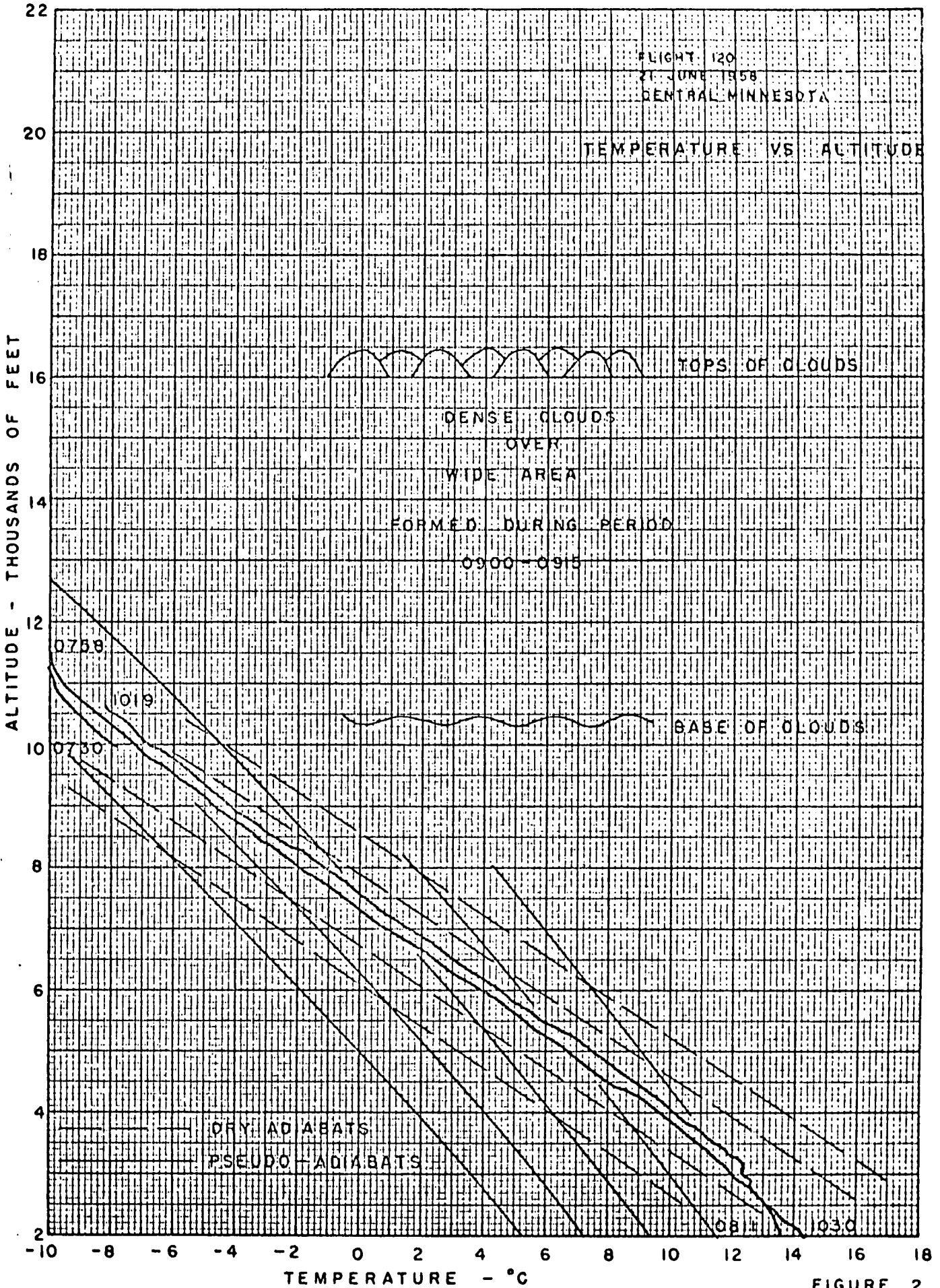


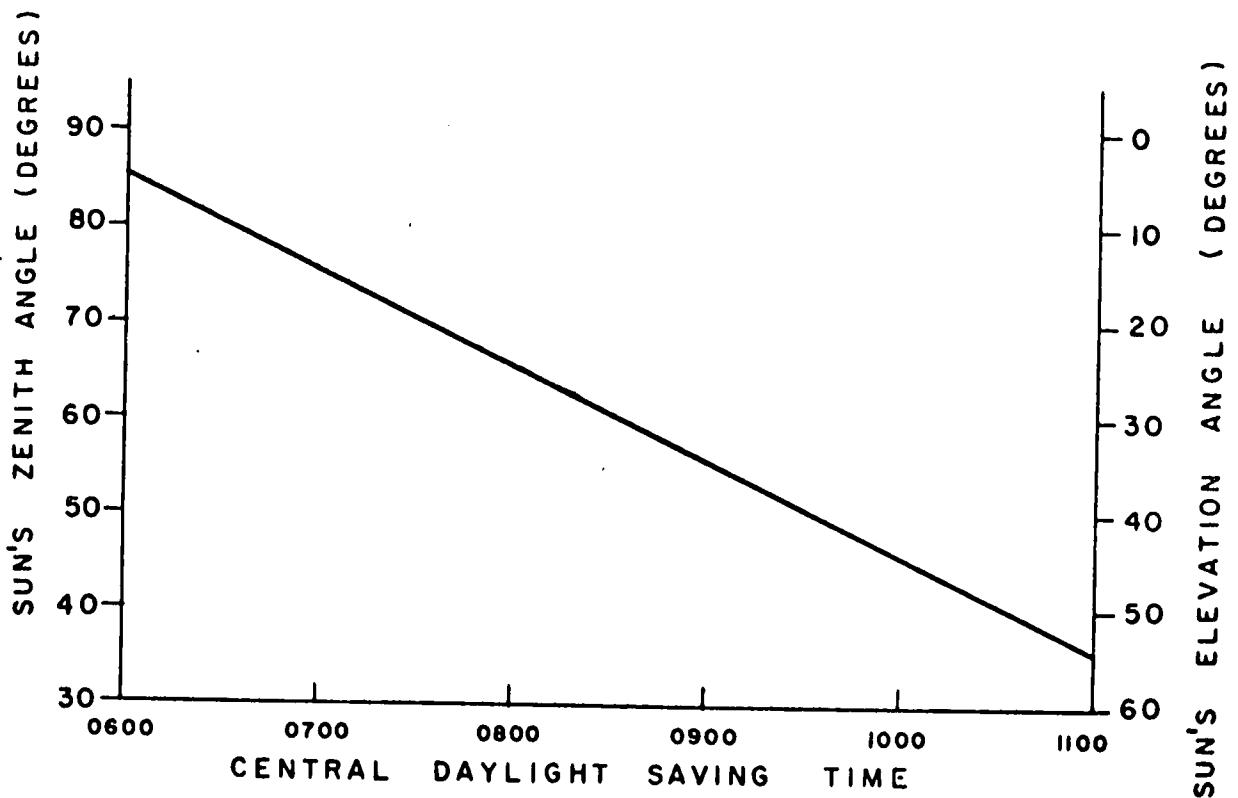
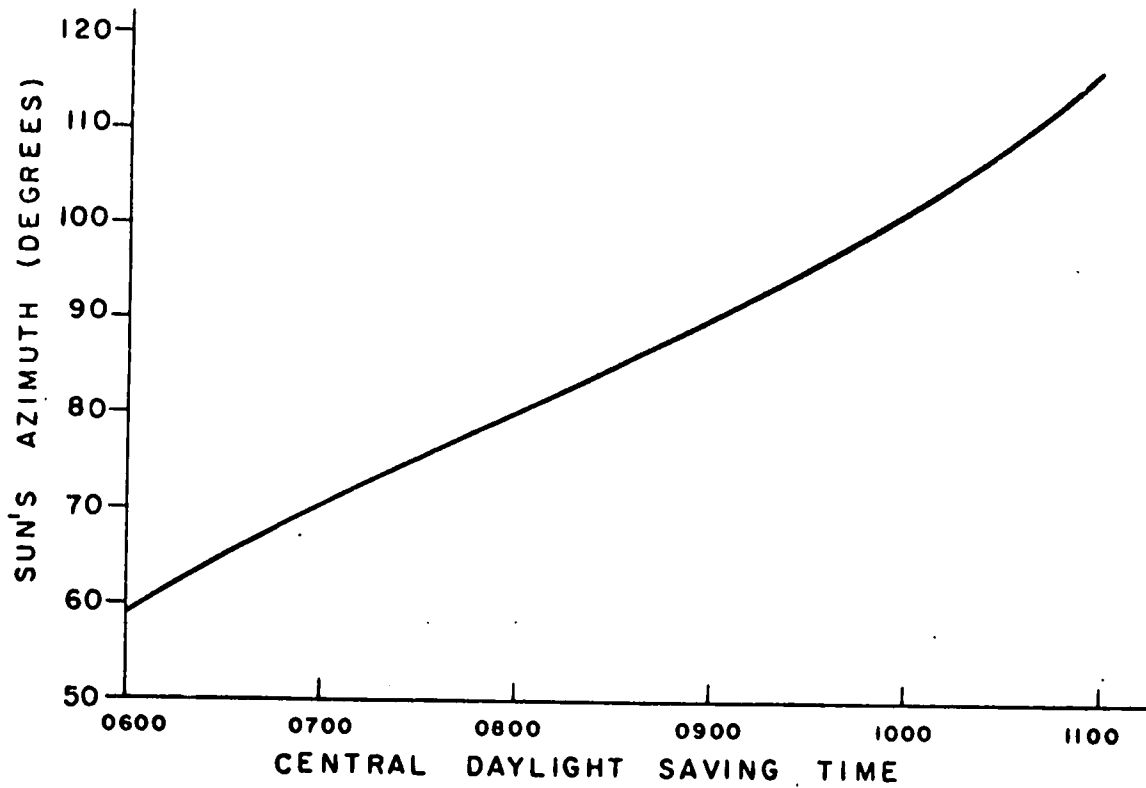
FIGURE 2

K&E
10 X 10 TO THE 1/2 INCH
KEUFFEL & ESSER CO.
ALBANY, N.Y.

2.3.2 Weather. Data were recorded during the time that the airplane was flown at the several selected altitudes listed in the Recording Schedule and also during the time that the airplane was losing altitude at approximately 1000 feet per minute. Temperature of the ambient air was recorded during these descending runs as registered by an ML-471/AMQ-8 indicating resistance thermometer. A plot of temperature as it varied with altitude and time is shown in Fig. 2 preceding this page. In this figure there are observations of cloud conditions noted at the time indicated. Lines representing dry adiabats and pseudo-adiabats are plotted in this figure near the temperature profiles.

Photographs (Kodachrome transparencies) from which color prints were made show the scattered clouds which were present at 0700, 0753, and 0945. The color prints are presented in Part I of this report.

2.3.3 Position of Sun. The zenith angle and azimuth of the sun computed for 46° North Latitude and 94° West Longitude are shown in Fig. 3. These coordinates were selected because the balloons ranged from approximately 93° to 95° West Longitude in the vicinity of 46° North Latitude. The angles are plotted for the time period from 0600 to 1100 Central Daylight Saving Time. The ordinates of the lower graph are shown as zenith angle values on the left side of the graph and as elevation angle values on the right side of the graph, these angles being complementary.



AZIMUTH AND ZENITH ANGLE OF SUN DURING FLIGHT 120, COMPUTED FOR POSITION 46° N. LAT., 94° W. LONG.

FIGURE 3
FLIGHT NO. 120
JUNE 21, 1958
CENTRAL MINNESOTA

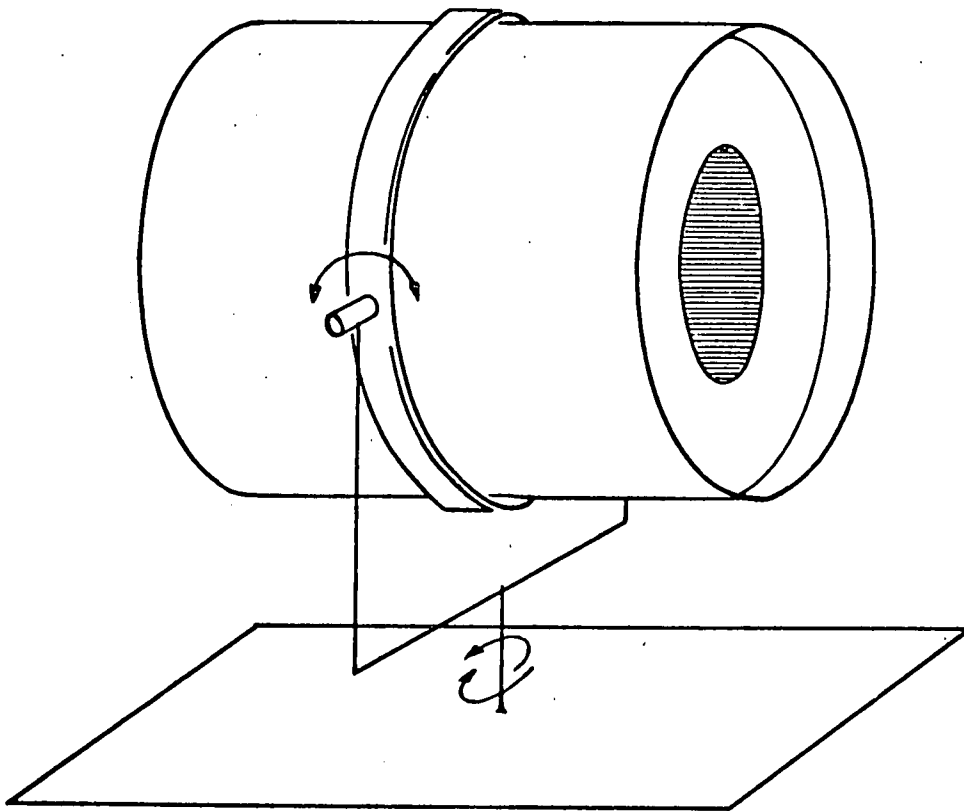
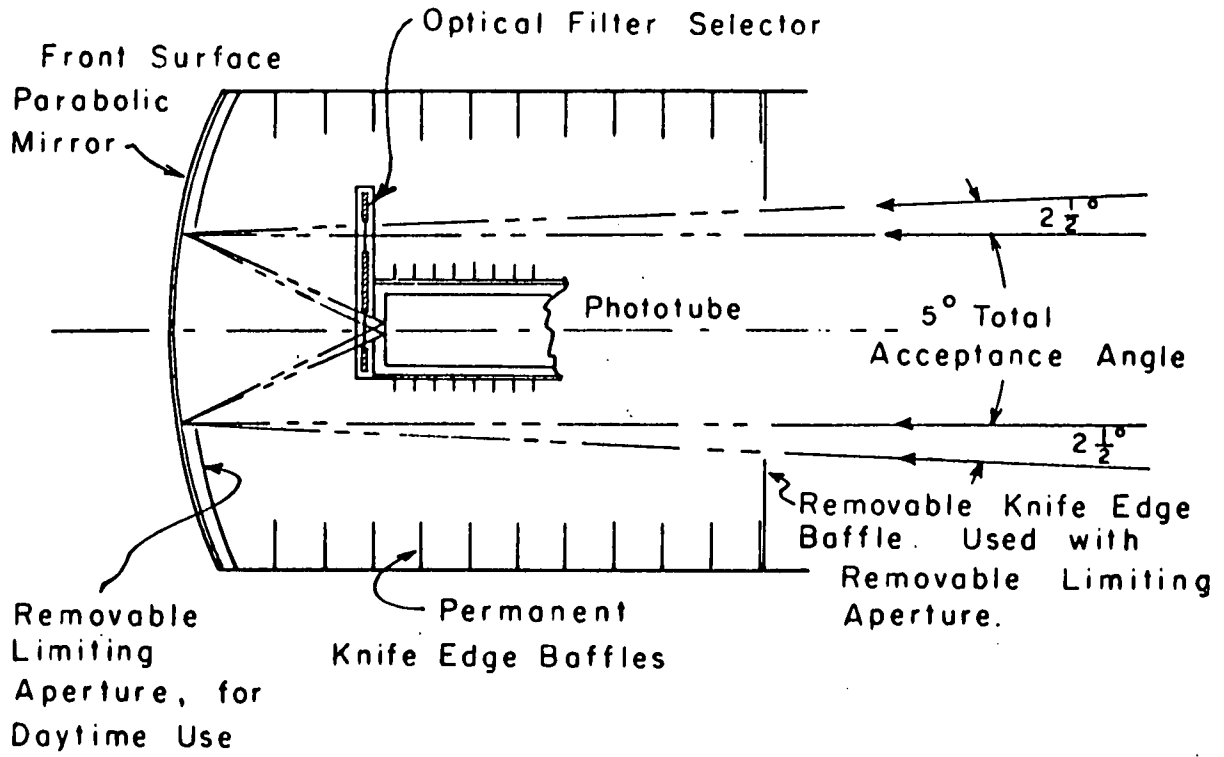
3. INTRODUCTION

3.1 Sky Scanning Telephotometers

3.1.1 Location. The two sky scanning telephotometers were carried by the XB-29, the upper one in the forward upper gun turret position and the lower one in a retracting mount in the rearmost lower gun turret position. The telephotometers were operated from the control position in the pressurized after compartment of the XB-29. Once started, both telephotometers continued their scanning operation until completion, at which time they automatically stopped and remained stopped until restarted.

3.1.2 Schematic. The sky scanning telephotometers are shown schematically in Fig. 4. The optical unit, shown at the top of the Figure, consists of a cylindrical shell with a 13" parabolic front surface mirror mounted on one end of the shell and an end-on multiplier phototube mounted with its light-sensitive surface at the focus of the mirror. A field stop in front of the light-sensitive surface limits the incoming rays to those contained in a 5° circular cone.

3.1.3 Light Level Range. The optical units of the sky scanning telephotometers were designed for use in both high and low light levels. For high light level or day time use the sensitivity of the photometer is reduced by the mirror limiting aperture. The flux incident on the phototube is further reduced by the use of neutral density filters. Internal scattering is kept to a minimum by the removal front knife-edge baffle and the permanent knife-edge throughout the inside lengths of the cylindrical shell and on the outside of the phototube housing.



SKY SCANNING TELEPHOTOMETER

FIGURE 4

3.1.4 Filters. In front of the field stop there is an optical filter selector mechanism by which by being operable from the control position permits any one of three optical filters to be interposed in the flux path. The relative spectral sensitivities of the three filter and phototube combinations are shown in Fig. 5.

The data presented in this part of the report are the data as seen by the photopic filter - phototube combination.

3.1.5 Scanning patterns. The scanning patterns of the two sky scanning telephotometers are such that the optical units scan in elevation with a change of azimuth occurring in the case of the upper scanner between elevation scans and in the case of the lower scanner simultaneously with the elevation scans.

The upper sky scanning telephotometer starts from $2\ 1/2^\circ$ below the horizontal, scans upward through the zenith and continues downward to $2\ 1/2^\circ$ below the horizontal 180° from the starting azimuth. At the conclusion of an elevation scan the scanner shifts 10° in azimuth and then starts a return elevation scan. It makes eighteen elevation scans thereby completing the upper sky in 90 seconds. At the end of the eighteenth elevation scan the azimuth drive reverses and the scanner scans the sky, in the reverse sequence, in 90 seconds. A change of optical filters during the time of reversal permits two complete upper sky measurements to be completed in three minutes.

As stated above, the scanning pattern of the lower sky scanning telephotometer differs from the scanning pattern of the upper sky scanning telephotometer but because the lower scanning telephotometer was inoperative and no data were recorded, the scanning pattern of this instrument will not be discussed.

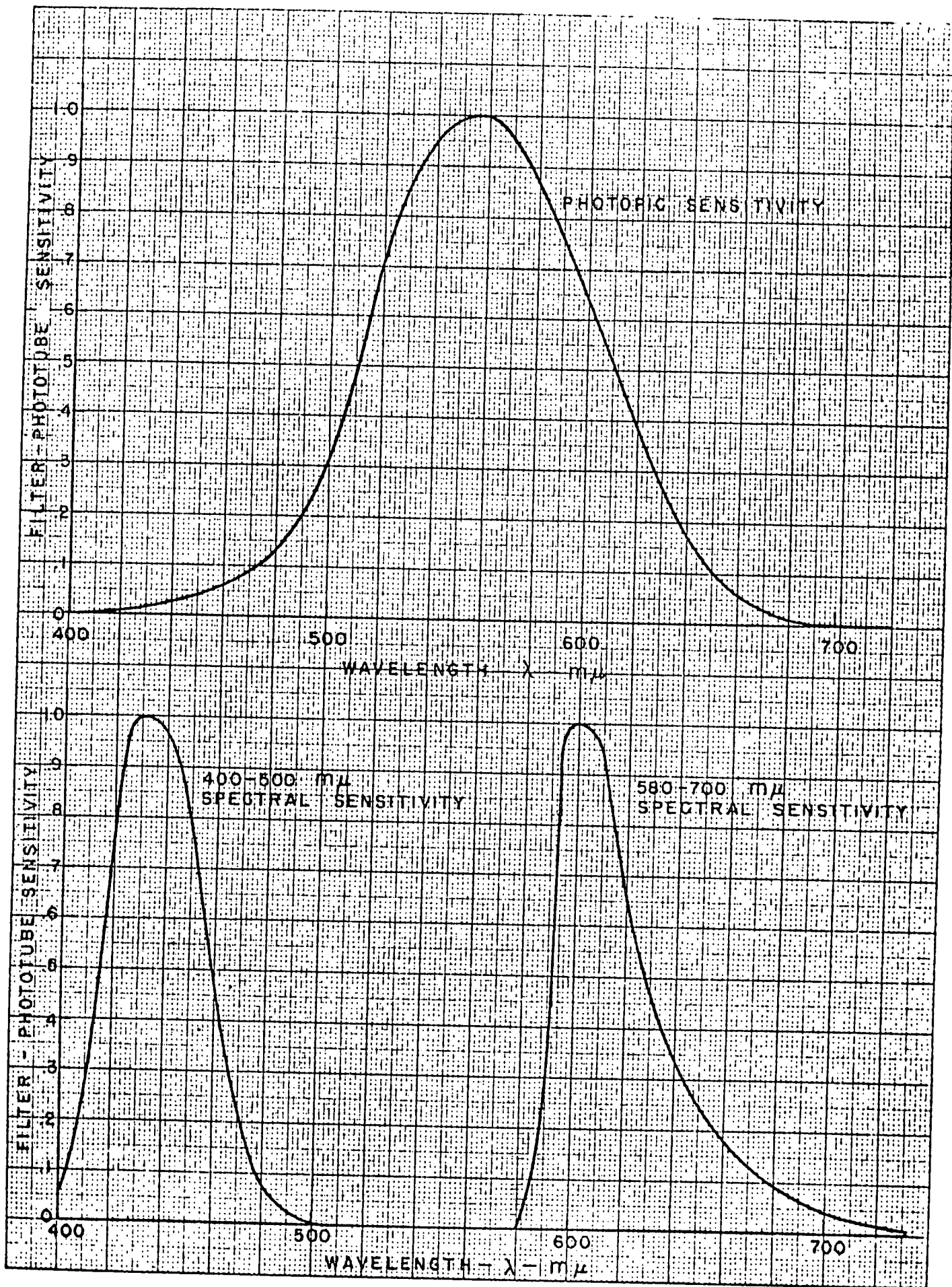


FIG. 5

4. DATA TREATMENT

4.1 Data Recording

The sky luminance and radiance distribution values were recorded during Flight 120 on Minneapolis-Honeywell "Brown ELECTRONIK" Recorder strip chart. The data were recorded as a continuous analog trace representing the value of sky luminance or radiance depending on which optical filter was in the flux path as the scanner operated through its cycle. The angular positions of the scanner in elevation, that is, its zenith angle positions, were indicated by a marking stylus which was activated by a microswitch in contact with a protractor type cam. The data recording stylus and the zenith angle marking stylus recorded continuously and simultaneously so that zenith angle indications and corresponding sky luminance or radiance data were synchronized. Because the scanner always started from and stopped in the same azimuthal position, the azimuth of each elevation scan was easily determined by counting the number of elevation scans.

4.2 Data Reduction

The strip chart data were transferred to IBM computer cards by the use of computer peripheral equipment. Through the operation of a Burroughs No. 220 computer at the U.S. Navy Electronics Laboratory, San Diego, California, which was programmed to correct for the non-linearities of the airborne electronic recording equipment the data points were converted into tables of equivalent luminance and radiance

values. These values were plotted against azimuth values on semi-logarithmic paper, the azimuth being with reference to geographical north. The azimuthal scale marked off along the linear coordinates of the graph paper was then shifted to cause the azimuthal scale to indicate azimuth with reference to the sun. The last step was to re-plot the luminance and radiance values for selected zenith angles against altitude on semi-logarithmic graph paper. Continuous curves were then drawn through these points.

5. PRESENTATION OF DATA

5.1 Notation

The notation in this report follows the notation for the various radiometric and photometric optical quantities discussed in detail elsewhere.² The general symbol for radiance is N ; the symbol for its photometric counterpart, luminance, is B . The particular symbol for the radiance or luminance of a path of sight when neither the path length is specified nor the source of radiance identified is $N(z, \theta, \phi)$ or $B(z, \theta, \phi)$, the parenthetic symbols indicating that the photometer is at altitude z and that the path of sight is as specified by the zenith angle θ and the azimuth ϕ . The zenith angle varies from 0° for looking vertically upward to 180° for looking vertically downward. The azimuth in this report is with reference to the sun.

5.2 Organization of Data

The data are presented as a series of graphs which have altitude as the ordinate values and sky luminance or radiance as abscissa values. Each curve represents the sky luminance or radiance value for a specific

2. S.Q. Duntley, A.R. Boileau, and R.W. Preisendorfer, "Image Transmission by the Troposphere I," J. Opt. Soc. Am. 47, 499-506 (1957)

azimuth and a specific zenith angle. The curves for one specific azimuth are grouped together in one Figure, each Figure normally consisting of two sheets. The Figures are arranged in order of increasing azimuth of 20° increments starting with 0° and ending with 340° . This group of Figures is one "set" of Figures. There are two sets of Figures, viz., the set composed of Figures 7-24 covering the data starting with 21 000 feet at 0647 and ending with data recorded at 2000 feet at 0813 and Figures 25-42 covering data starting at 22 000 feet at 0907 and ending at 2000 feet at 1033.

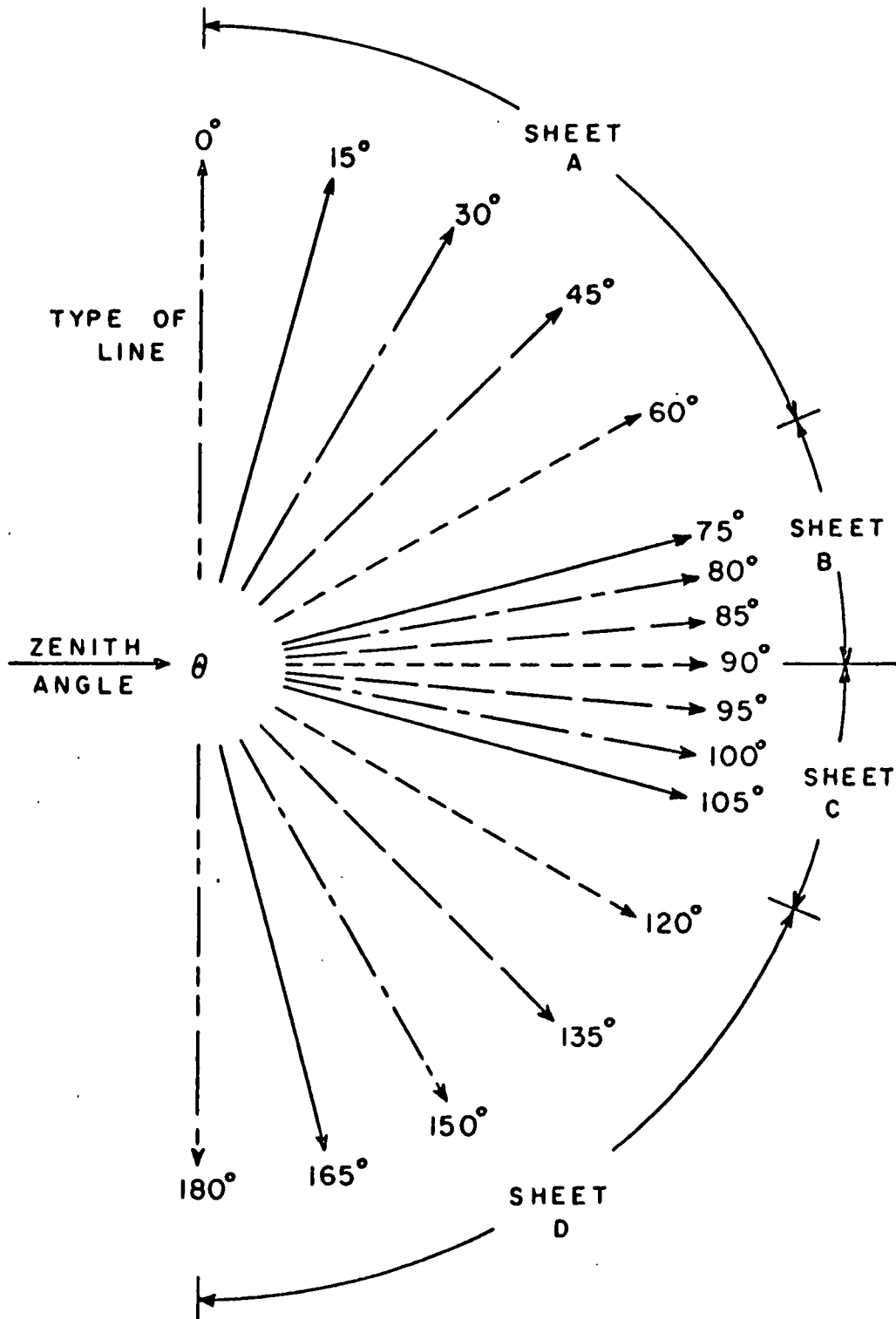
Each Figure, with several exceptions, consists of two sheets as follows:

Sheet a - zenith angles of 0° , 15° , 30° , 45° , and 60° .

Sheet b - zenith angles of 75° , 80° , 85° , and 90° .

To differentiate between the different graphs on each sheet, five distinctive types of lines are used. Fig. 6, immediately following this page, identifies the sheet, the zenith angles, and the distinctive line used for each zenith angle. (The four sheets indicated in this figure apply to both upper and lower sky presentation. However, in this report only two sheets, sheets a and b, are applicable.)

The exceptions to the above organization of data are for zenith angles close to the sun. In case of the first data Figure, i.e., Fig. 7, with azimuth of 0° , the data for zenith angle of 60° are presented on a separate sheet identified as "aa" in which the abscissa scale values have been increased by a factor of ten. This sheet (page 20) bears the warning "NOTE CHANGE OF SCALE." Sheet 7b of the same Figure (page 23) and part of Fig. 25 (page 58) also bears this warning.



LINES USED FOR SKY LUMINANCE AND RADIANCE PLOTS

FIGURE 6

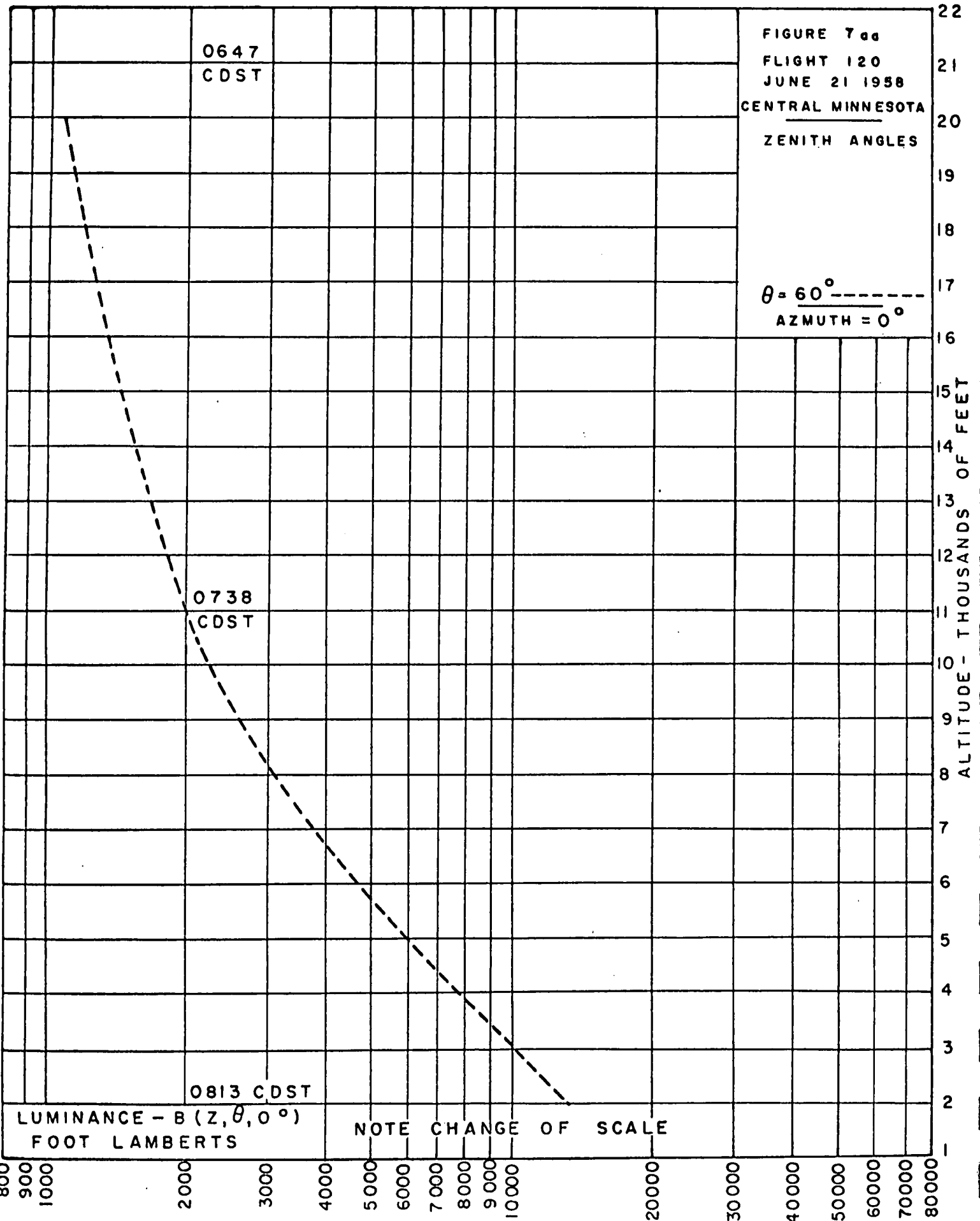
6. INDEX OF GRAPHS

6.1 First Set - Descent from 0647 to 0813

<u>Figure</u>	<u>Azimuth</u>	<u>Page</u>
7	0°	20
8	20°	24
9	40°	26
10	60°	28
11	80°	30
12	100°	32
13	120°	34
14	140°	36
15	160°	38
16	180°	40
17	200°	42
18	220°	44
19	240°	46
20	260°	48
21	280°	50
22	300°	52
23	320°	54
24	340°	56

6.2 Second Set - Descent from 0907 to 1033

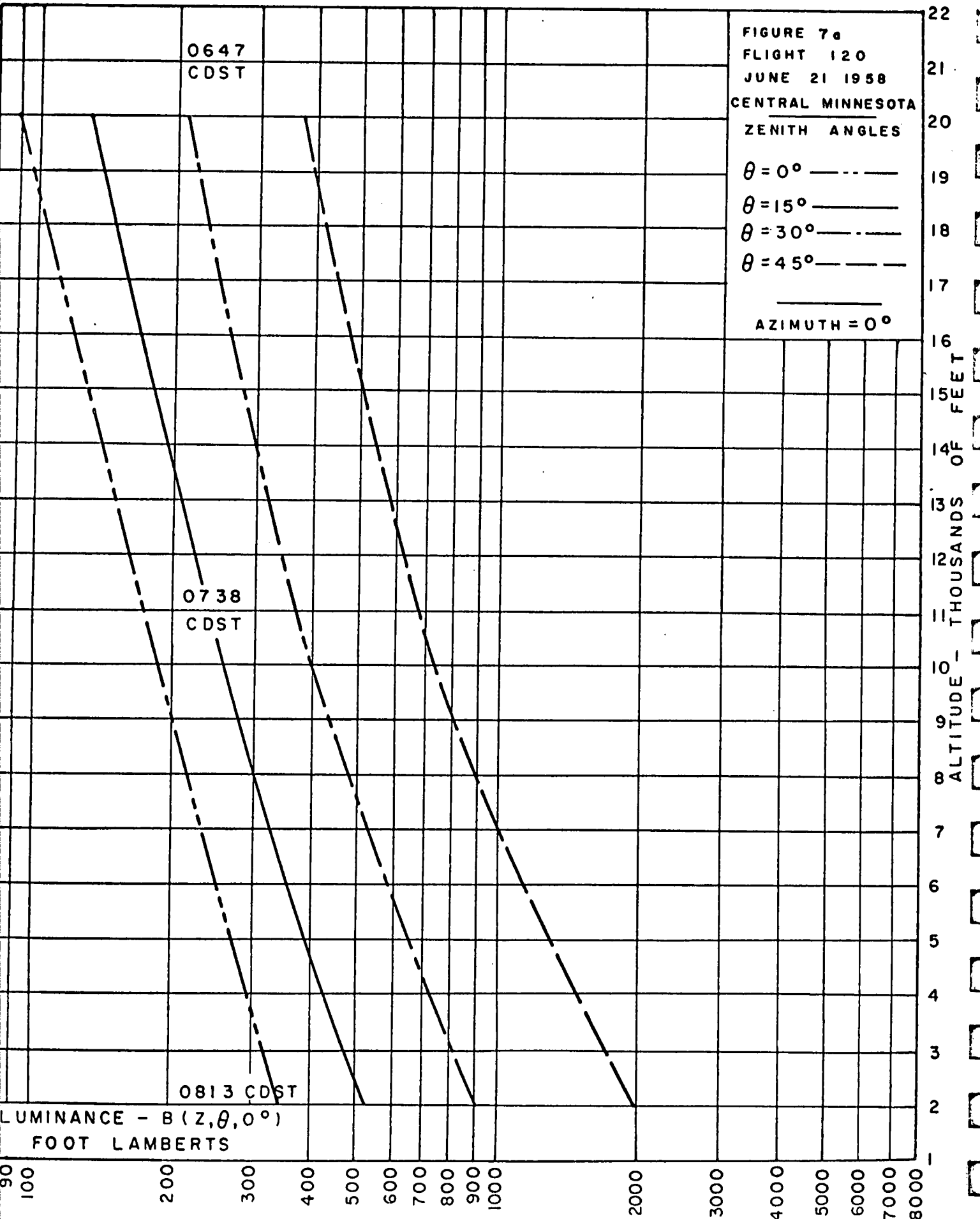
<u>Figure</u>	<u>Azimuth</u>	<u>Page</u>
25	0°	58
26	20°	62
27	40°	64
28	60°	66
29	80°	68
30	100°	70
31	120°	72
32	140°	74
33	160°	76
34	180°	78
35	200°	80
36	220°	82
37	240°	84
38	260°	86
39	280°	88
40	300°	90
41	320°	92
42	340°	94

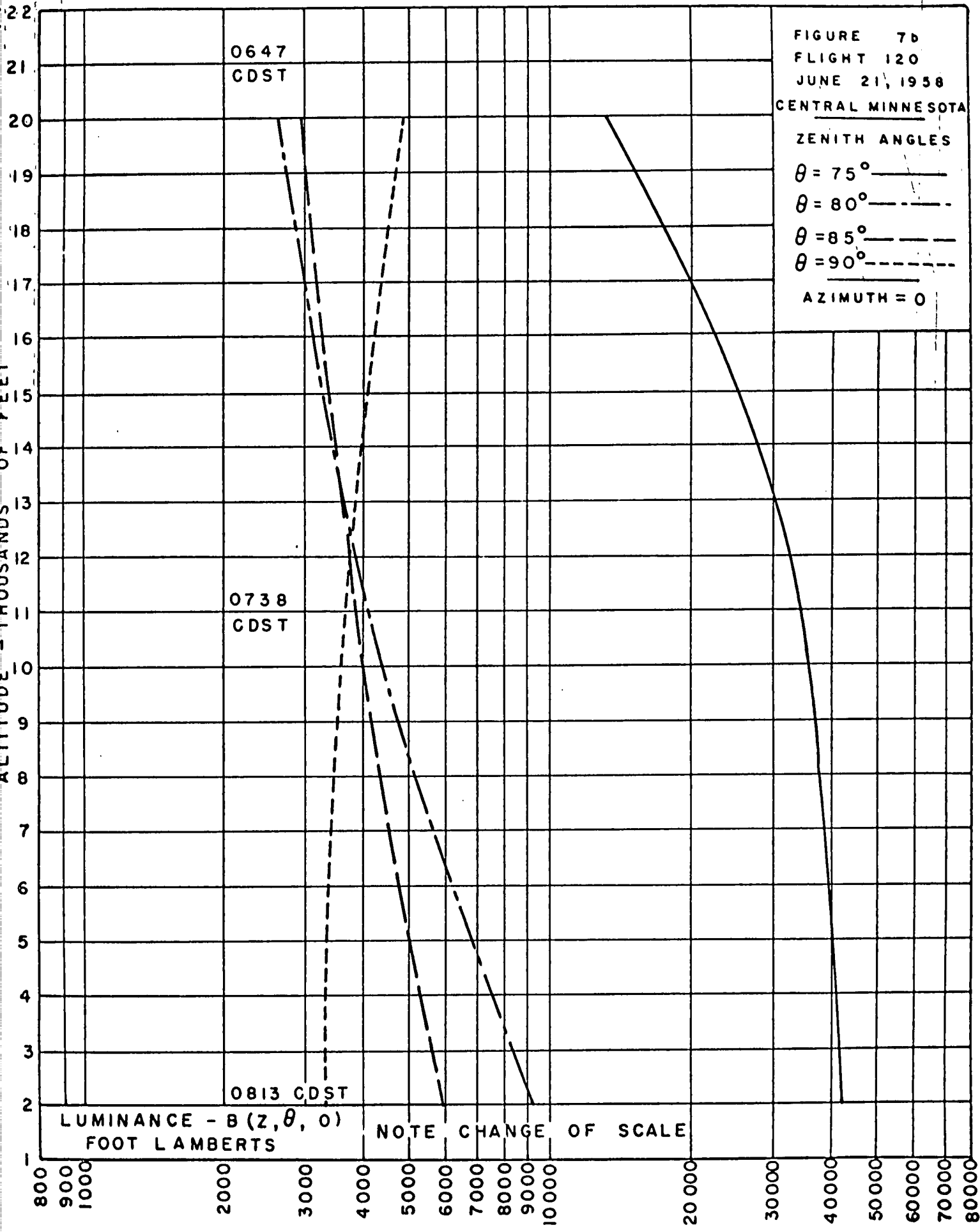


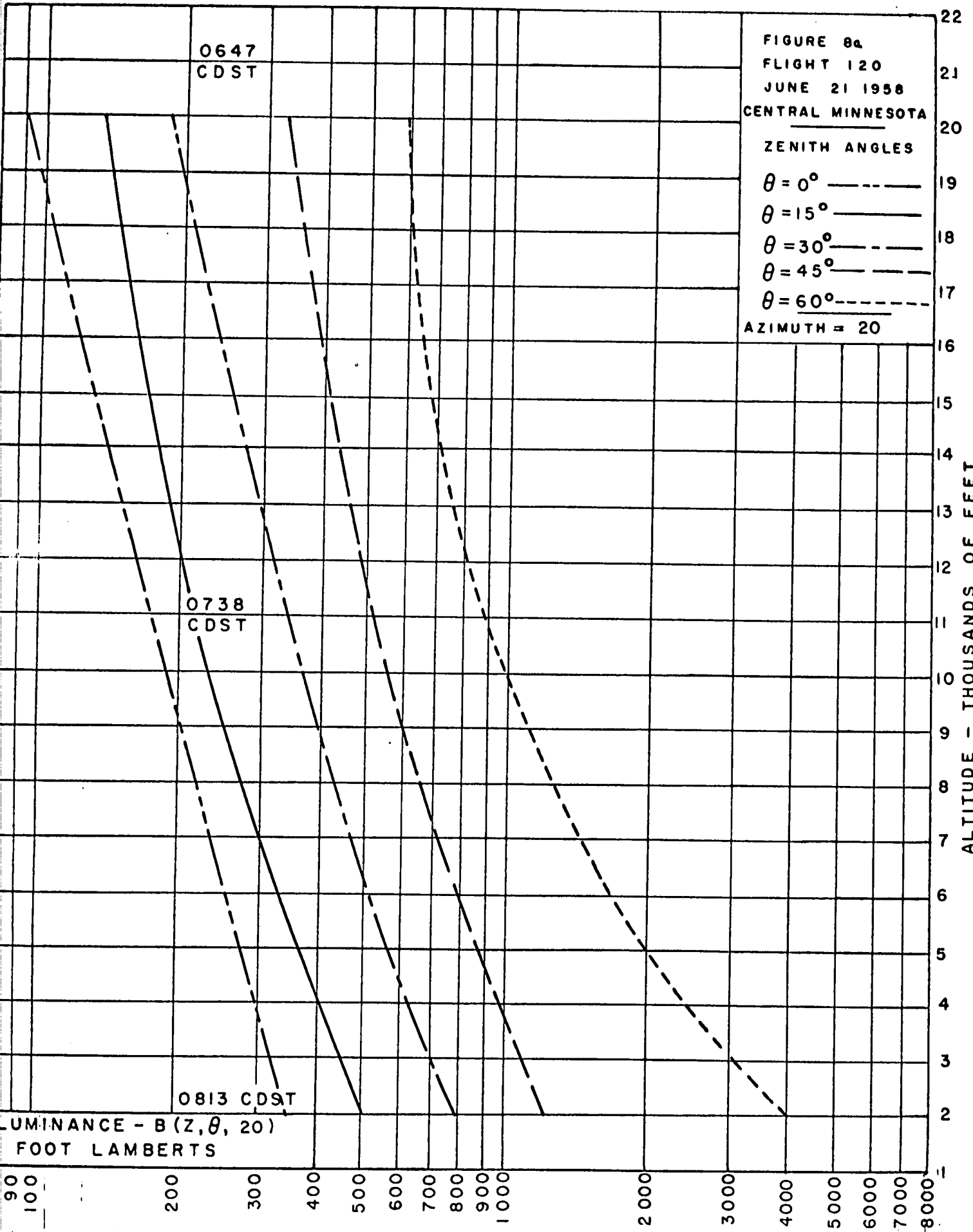
Note that Fig. 7aa bears the notation "NOTE CHANGE OF SCALE."

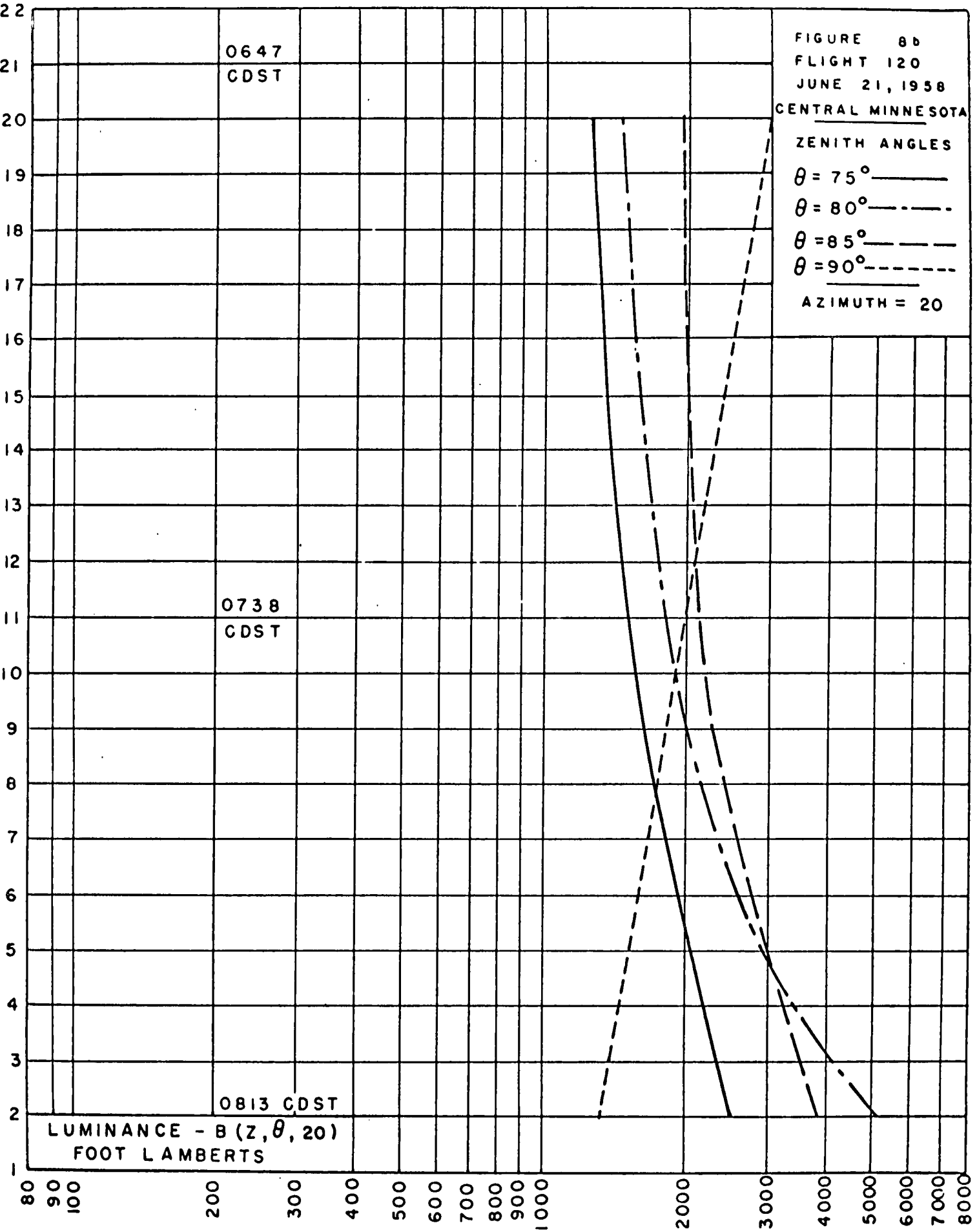
Usually the spread of luminance values does not exceed two orders of magnitude. In the case of the zero azimuth, i.e., the azimuth of the sun, the spread of luminance values does exceed two orders of magnitude due to the proximity of the sun. In order to keep the abscissa values of the graphs at two orders of magnitude it is necessary, in certain cases, to use a separate graph in which the abscissa values are increased by a factor of ten. The sky luminance in the azimuth of the sun for the zenith angle of 60° is a case in point.

Note that the luminance values in Fig. 7b, page 23, are also increased by a factor of ten and this Figure also has the notation "NOTE CHANGE OF SCALE."









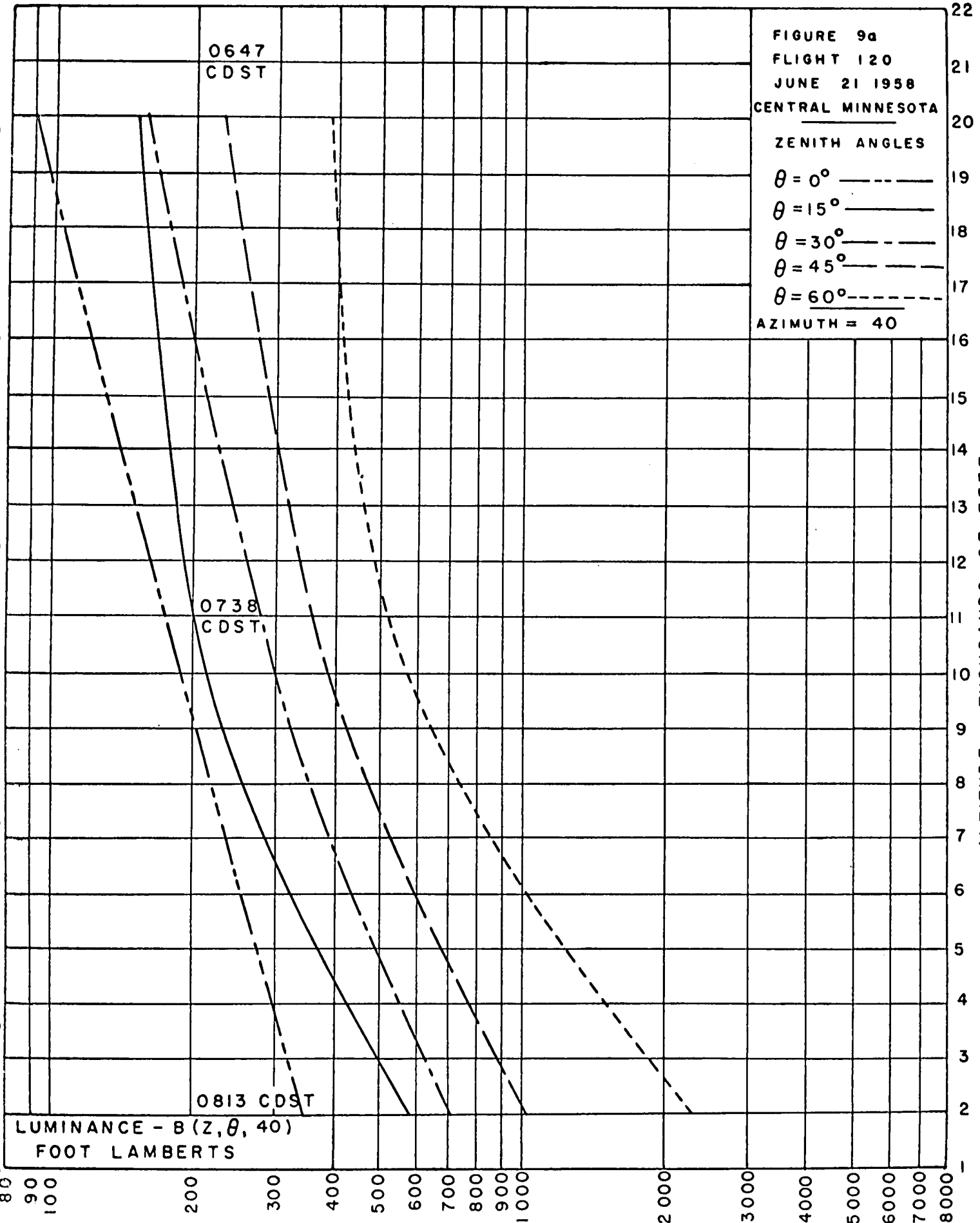


FIGURE 9a
FLIGHT 120
JUNE 21 1958
CENTRAL MINNESOTA
ZENITH ANGLES
 $\theta = 0^\circ$ -----
 $\theta = 15^\circ$ _____
 $\theta = 30^\circ$ - · - · -
 $\theta = 45^\circ$ - - - -
 $\theta = 60^\circ$ · · · ·
AZIMUTH = 40

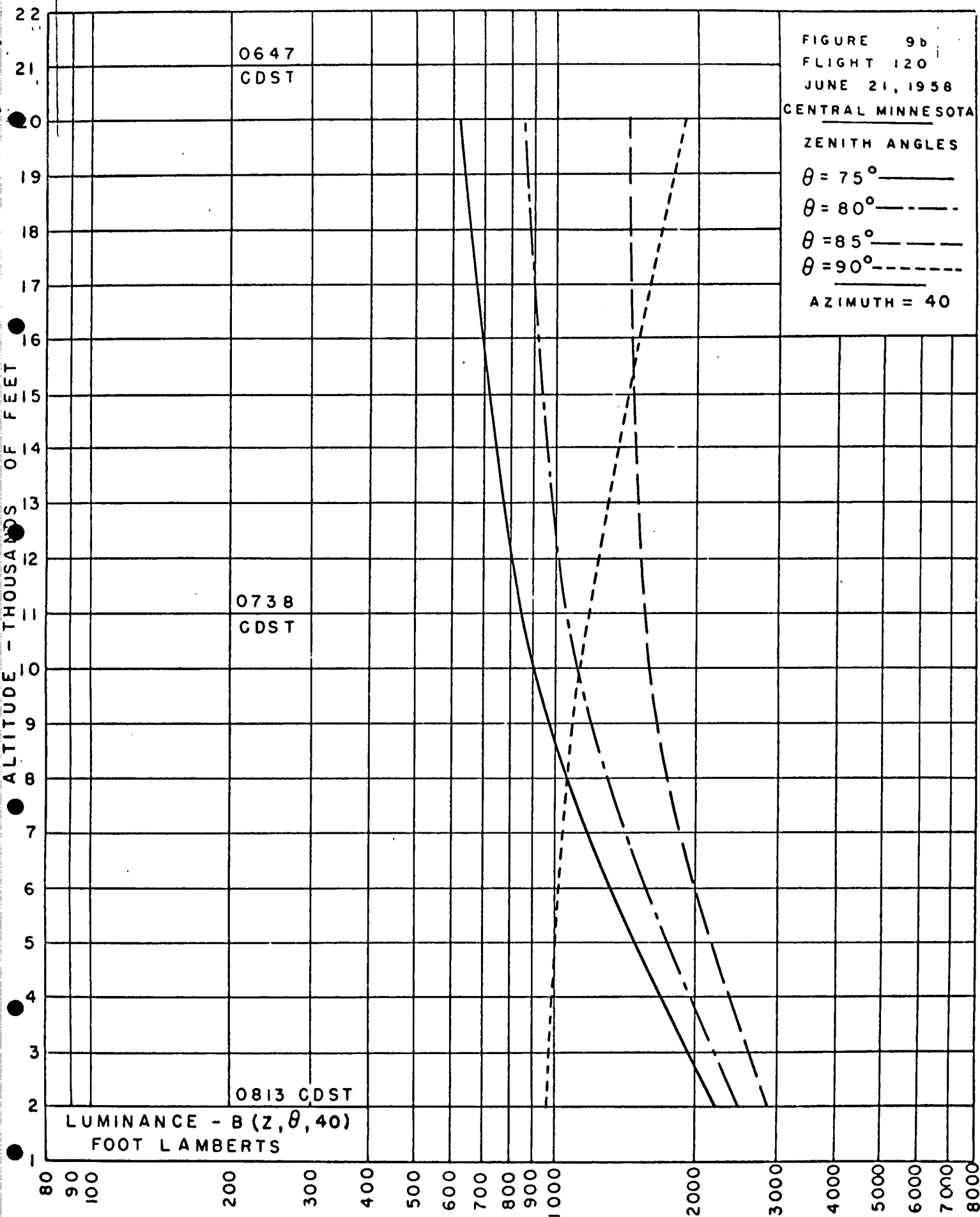
0647
CDST

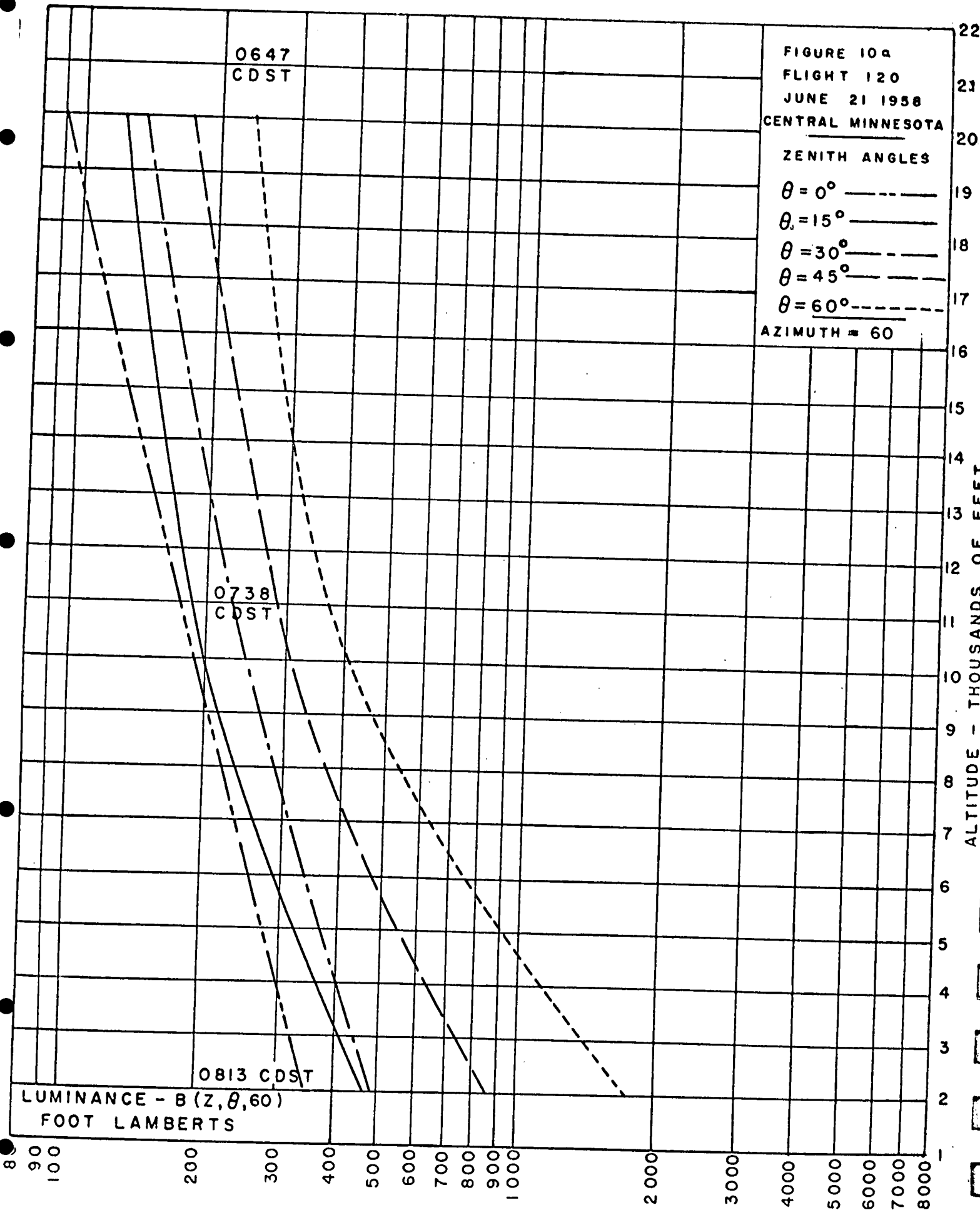
0738
CDST

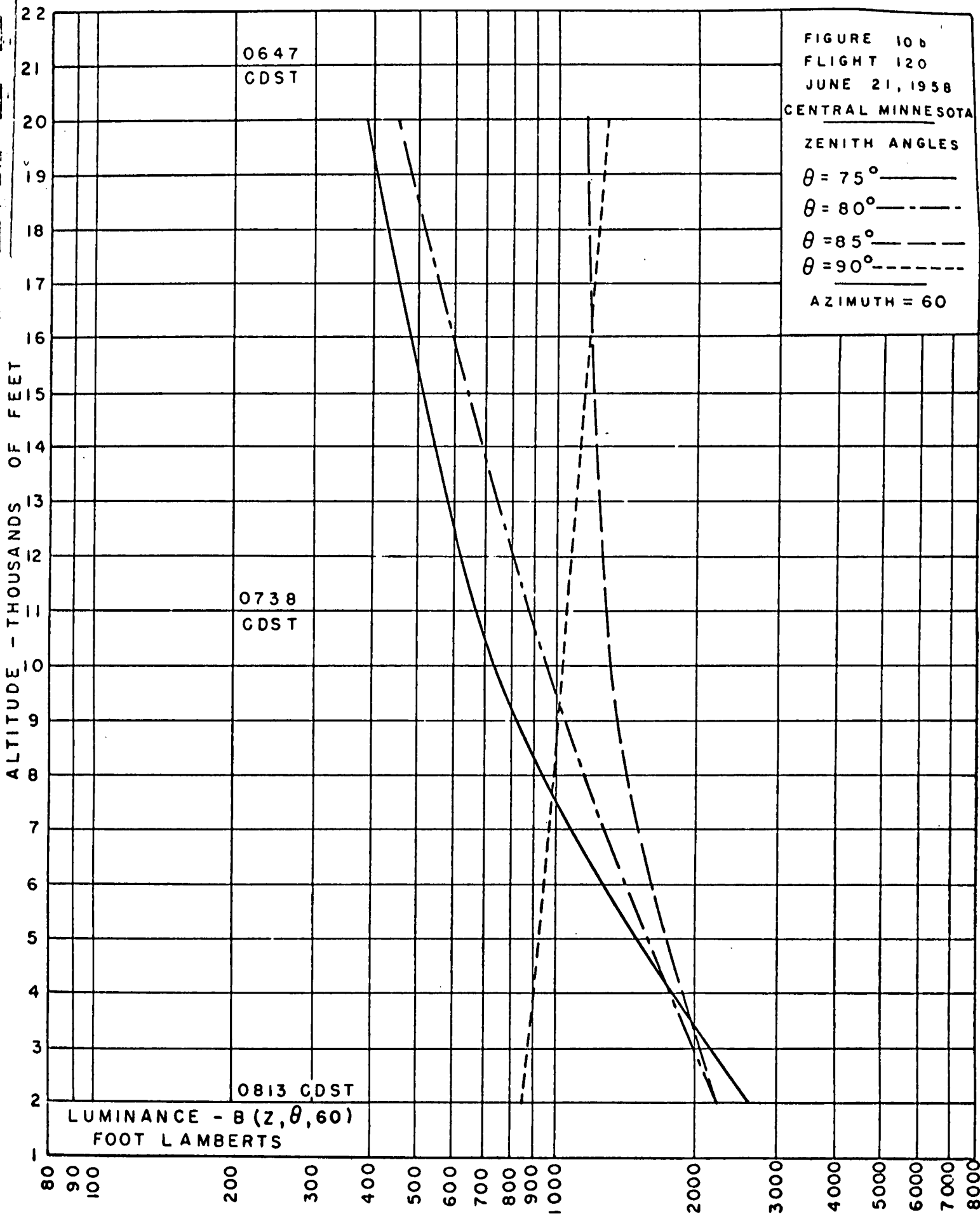
0813 CDST

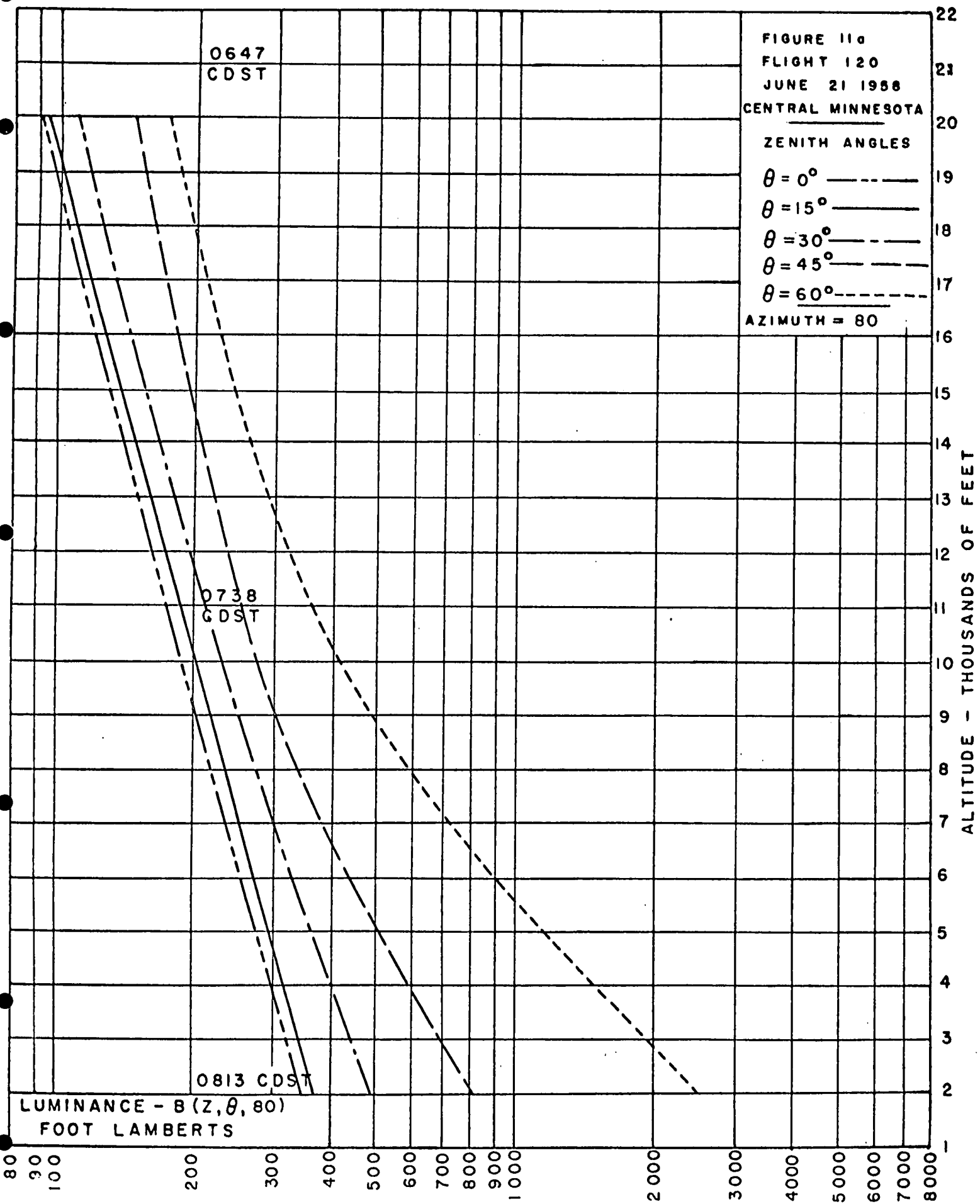
LUMINANCE - $B(Z, \theta, 40)$
FOOT LAMBERTS

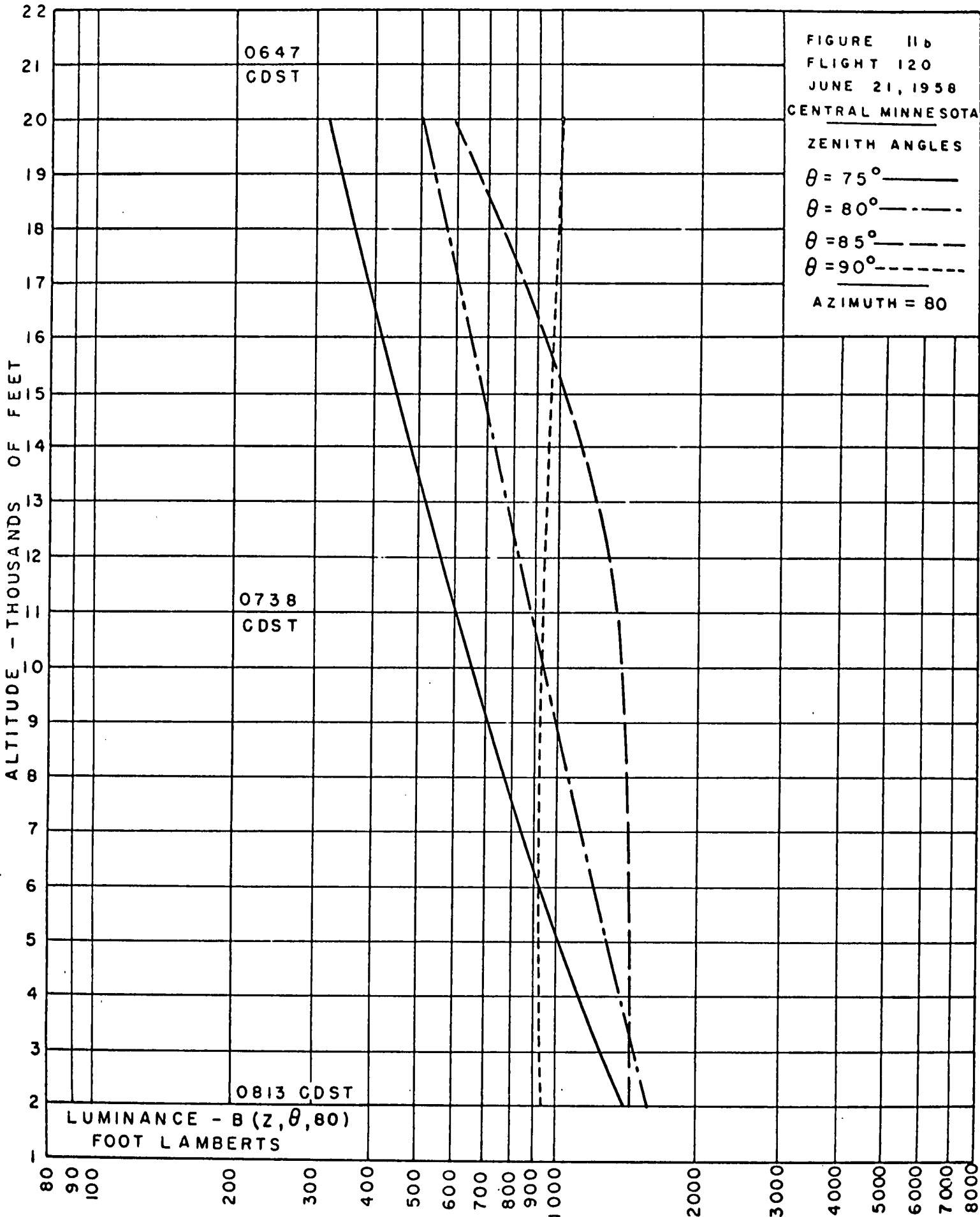
ALTITUDE - THOUSANDS OF FEET

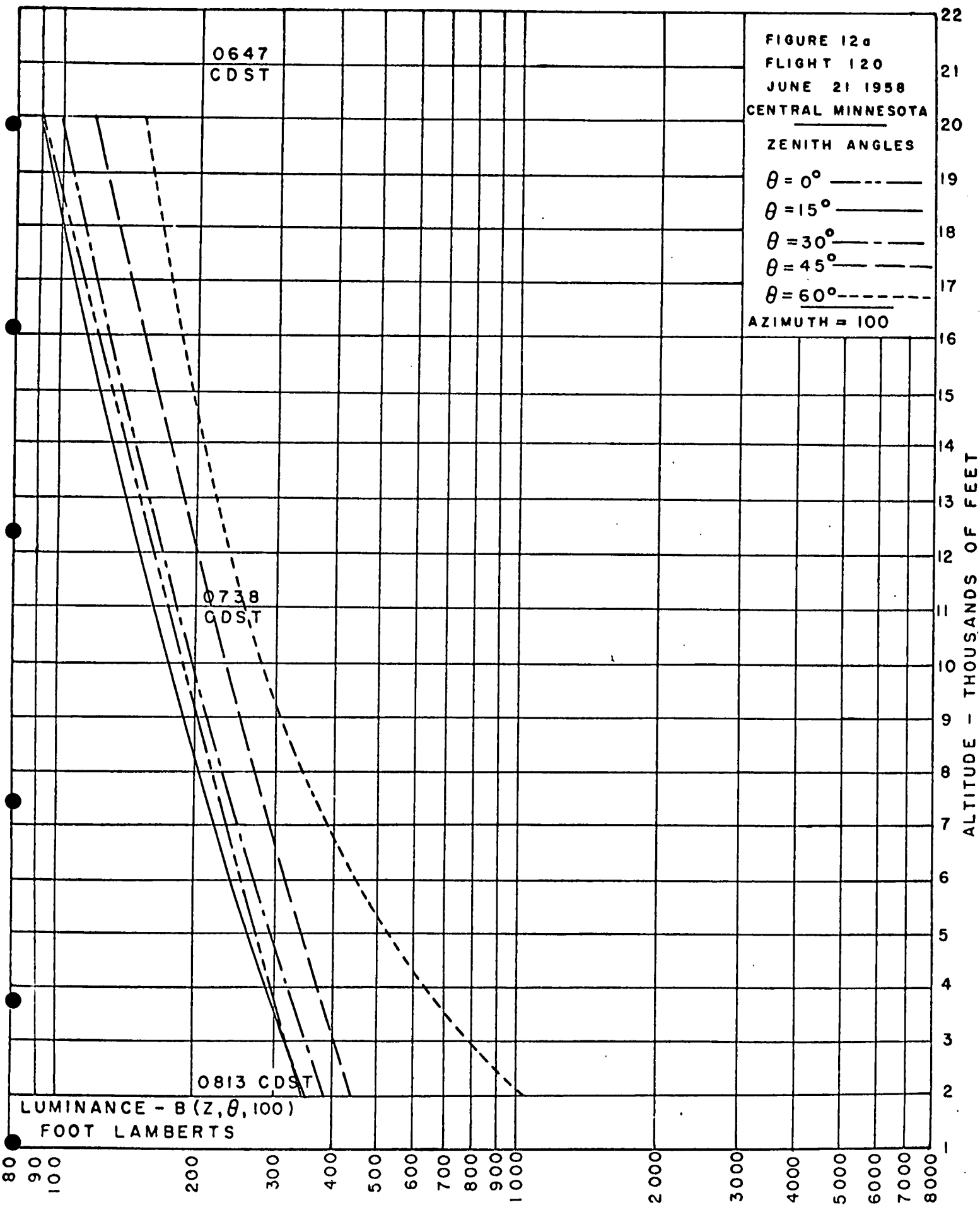


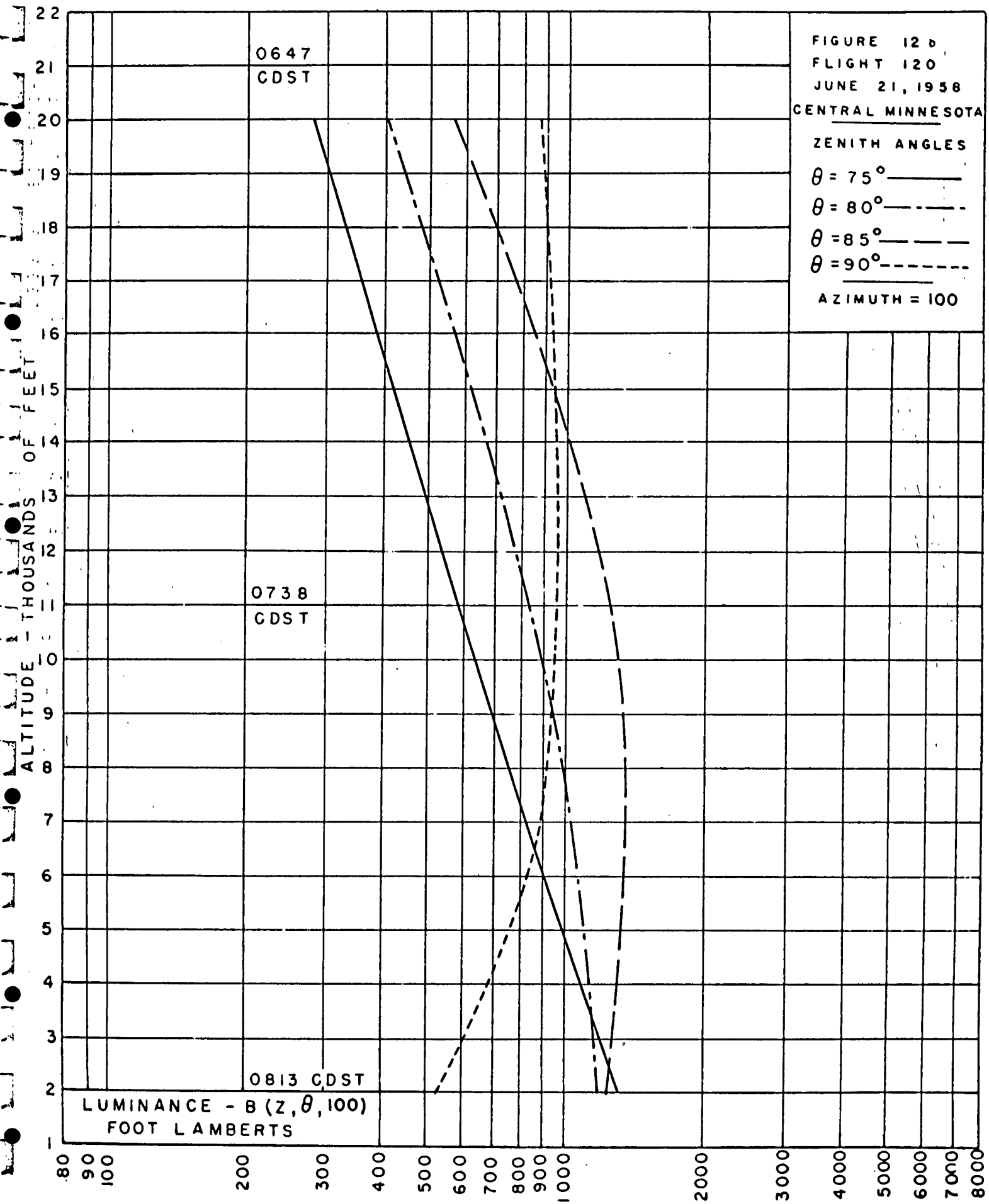


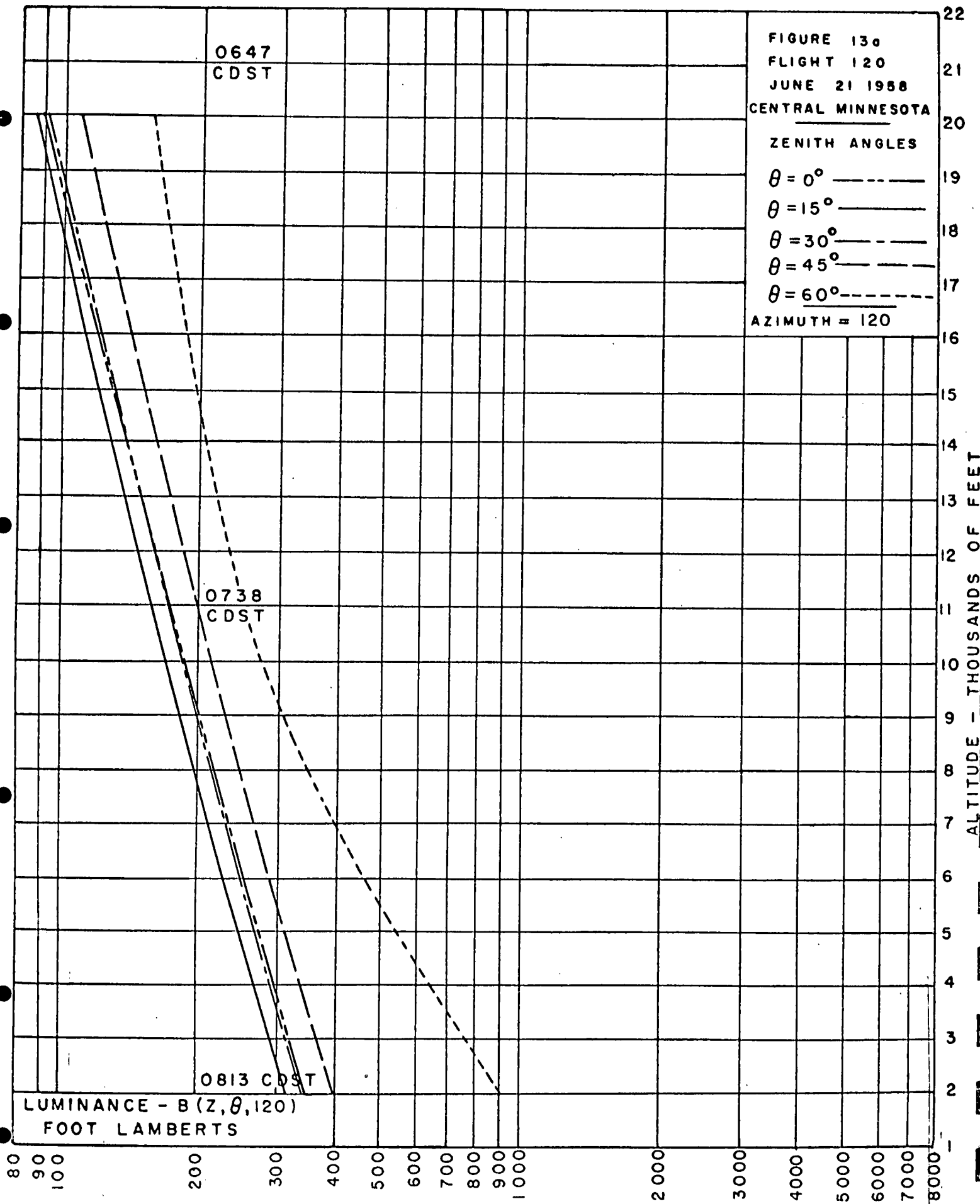


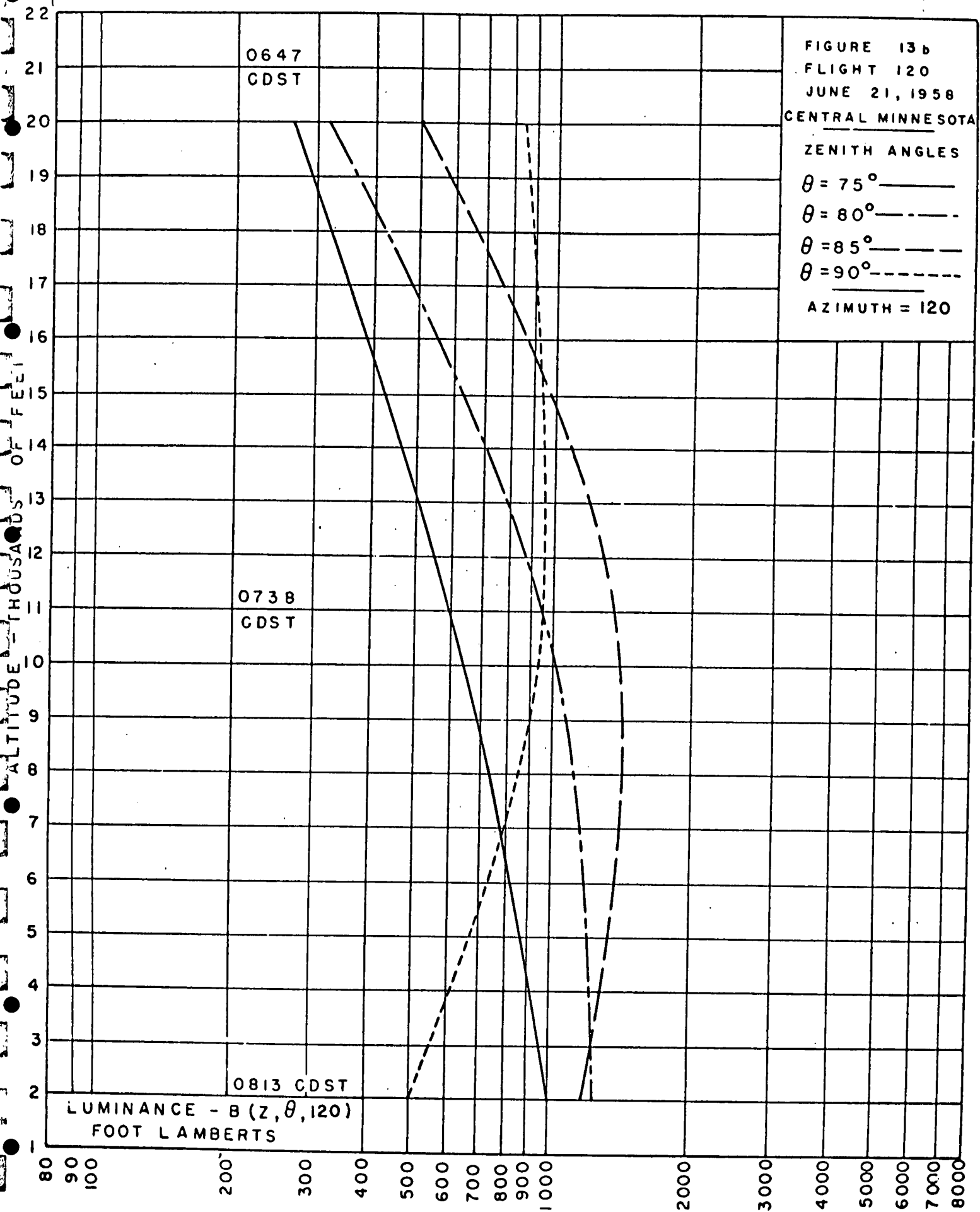


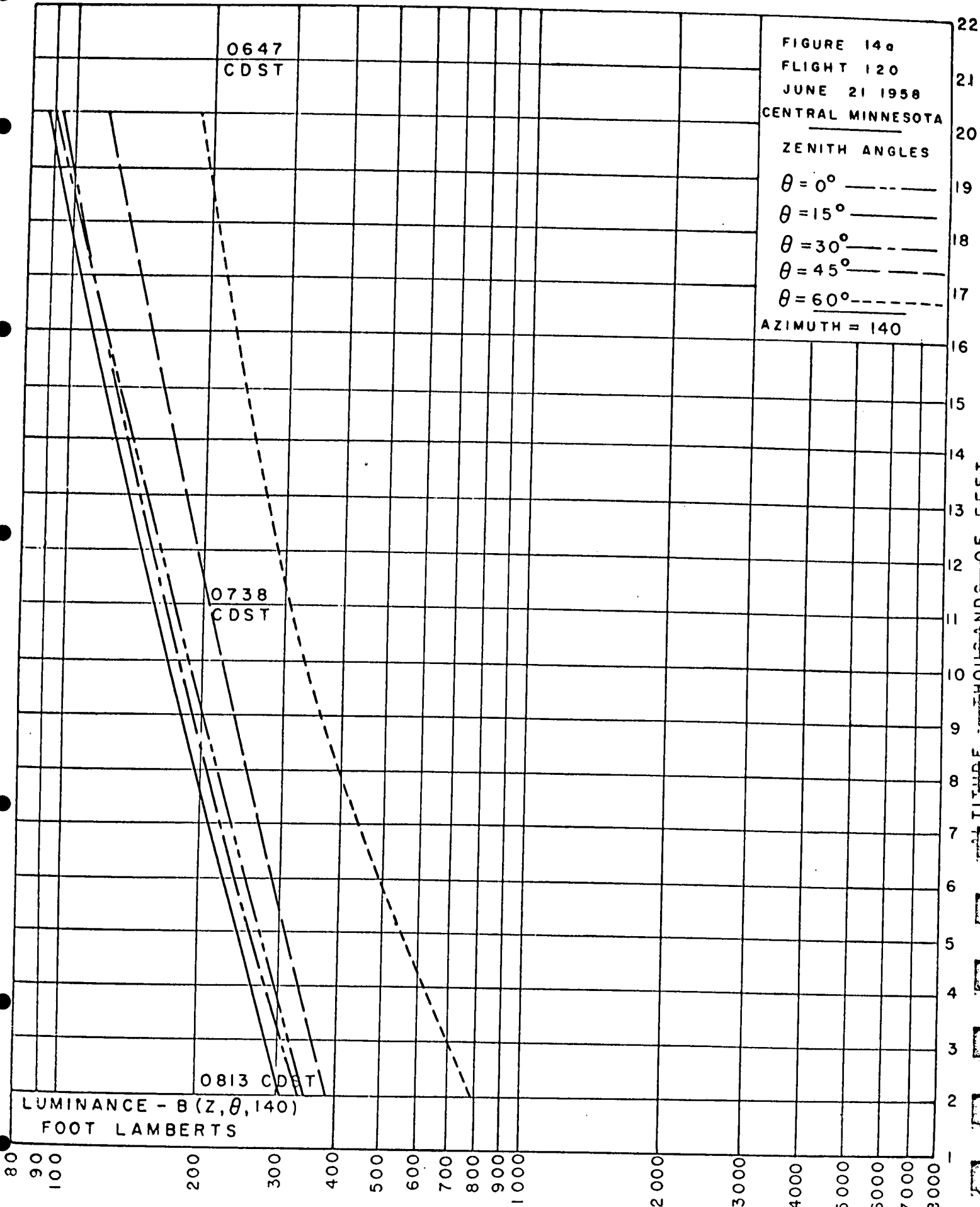


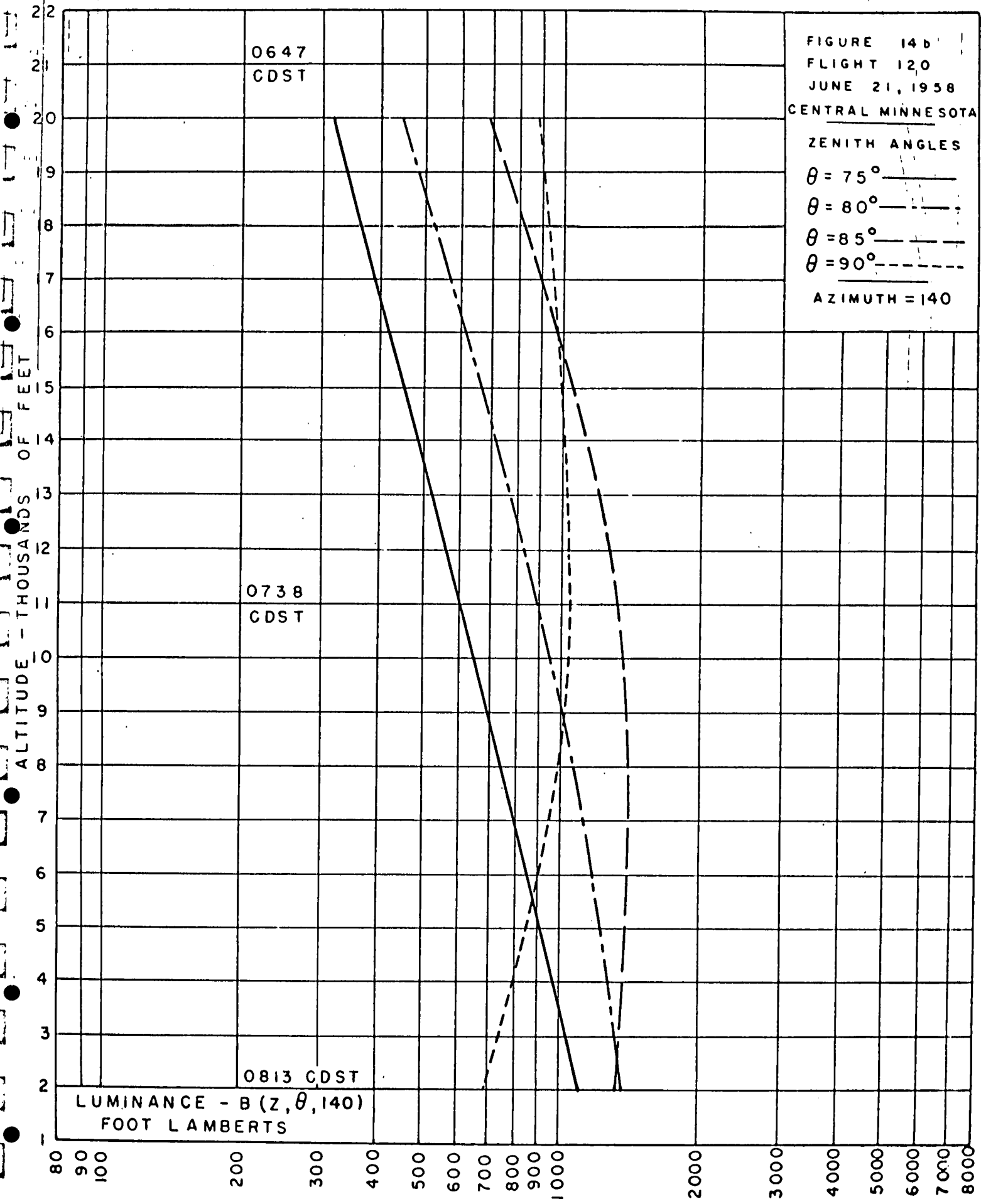


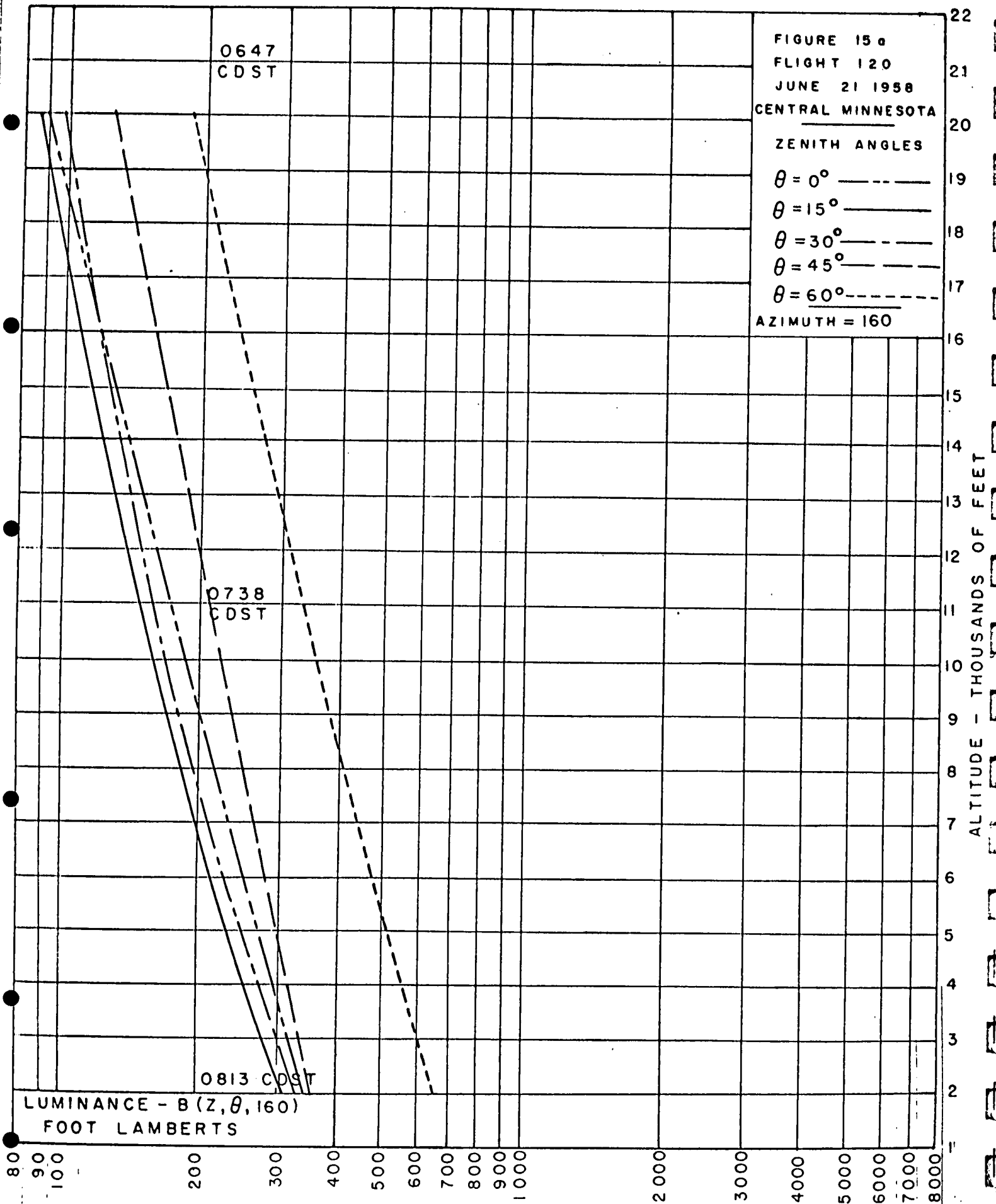


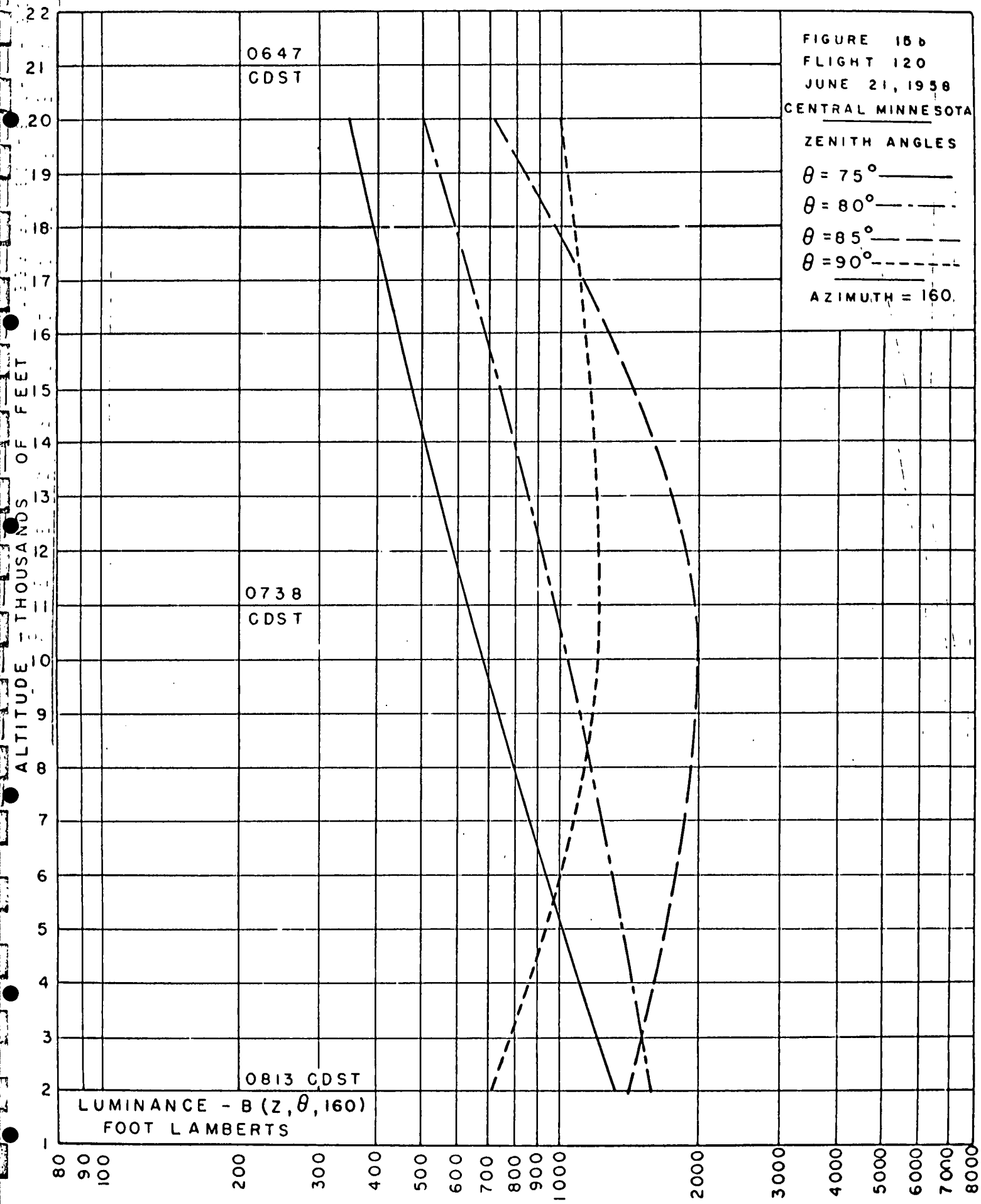


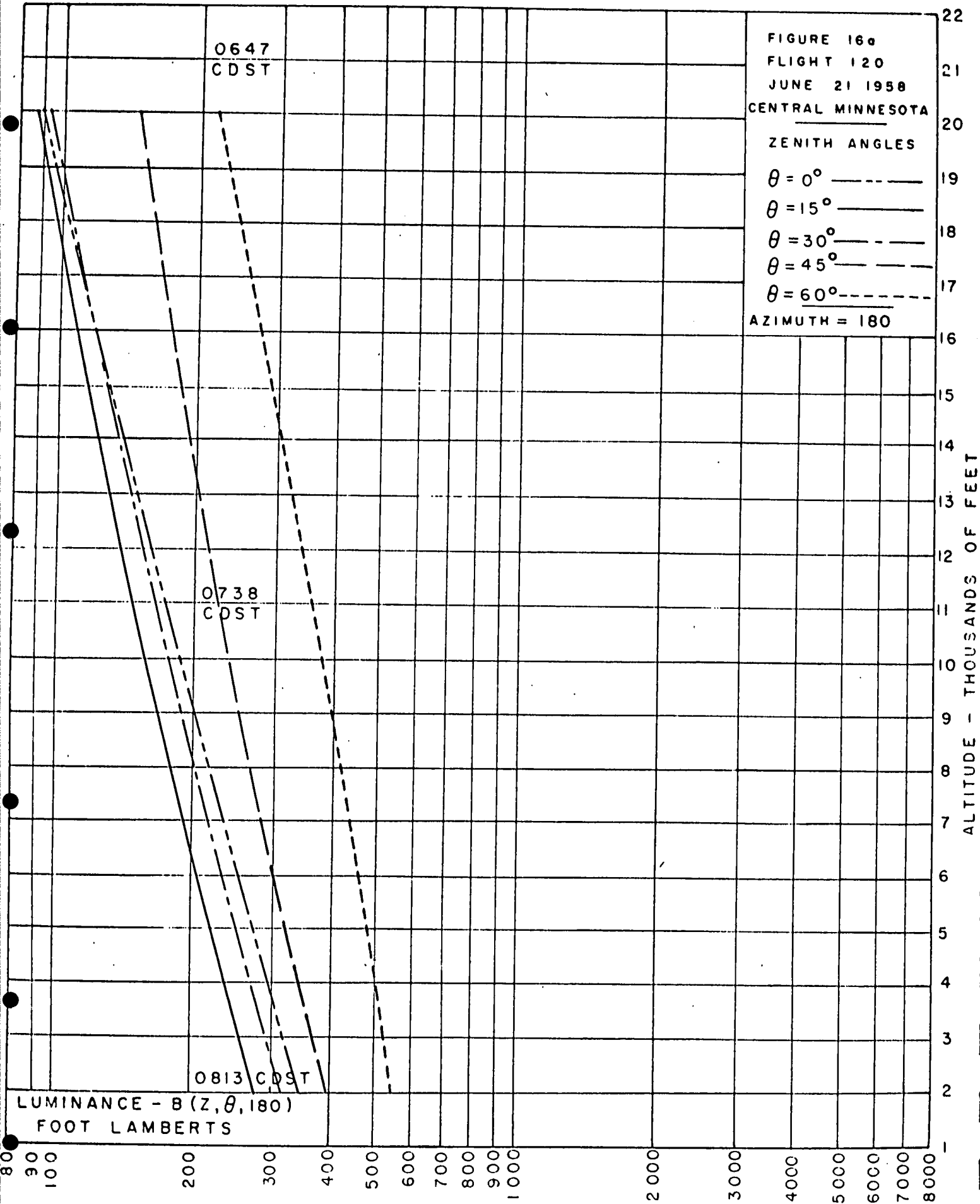


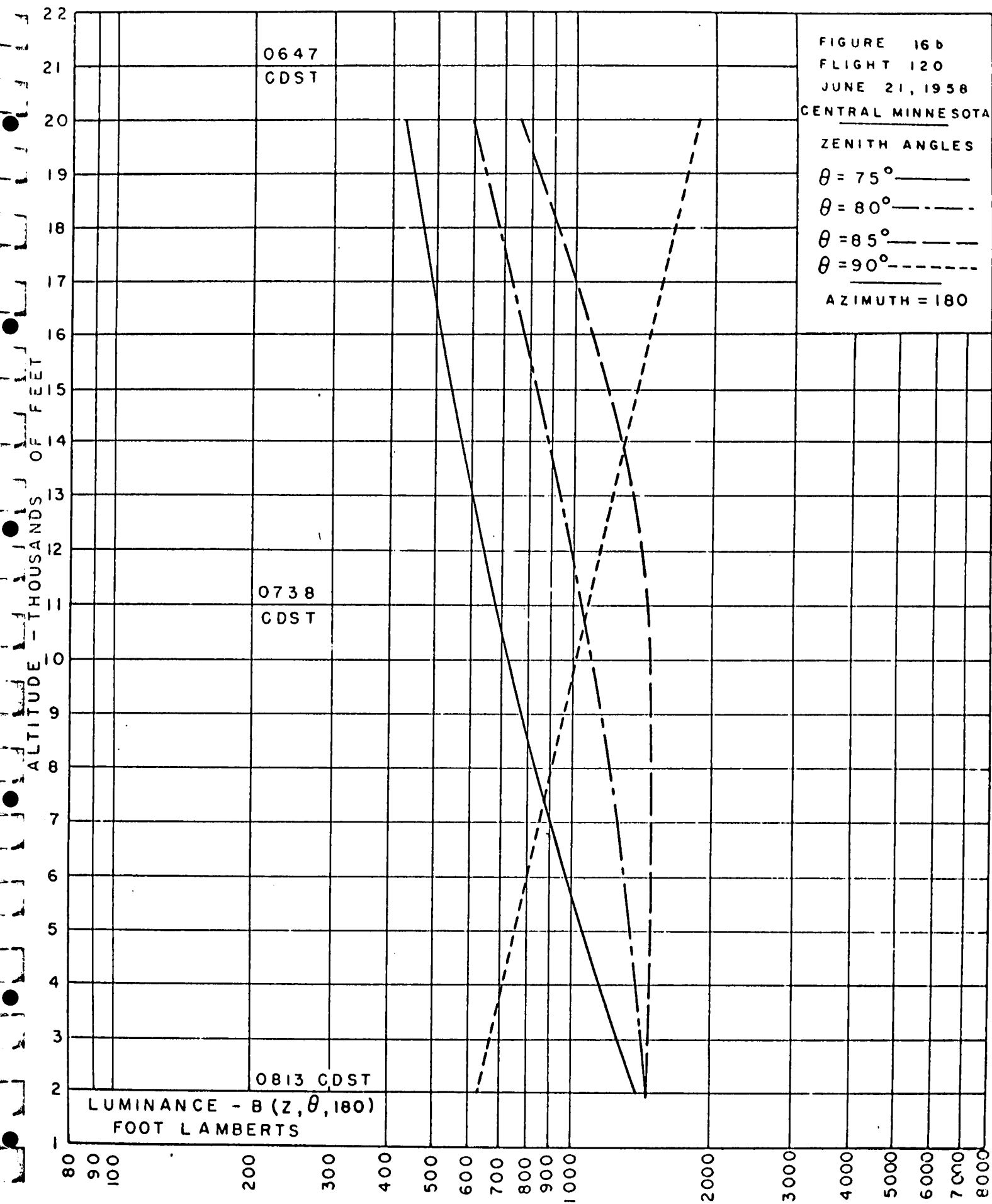


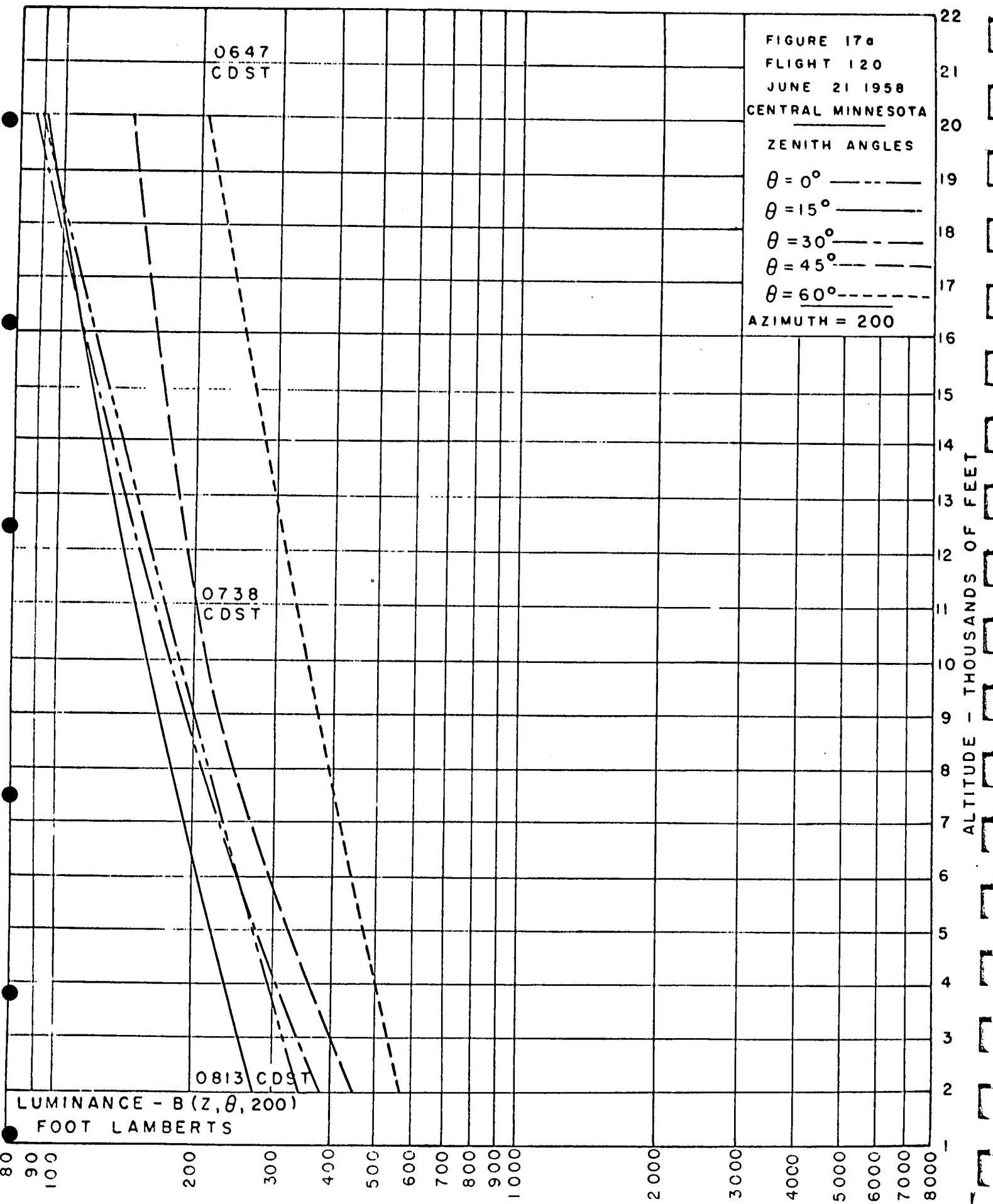


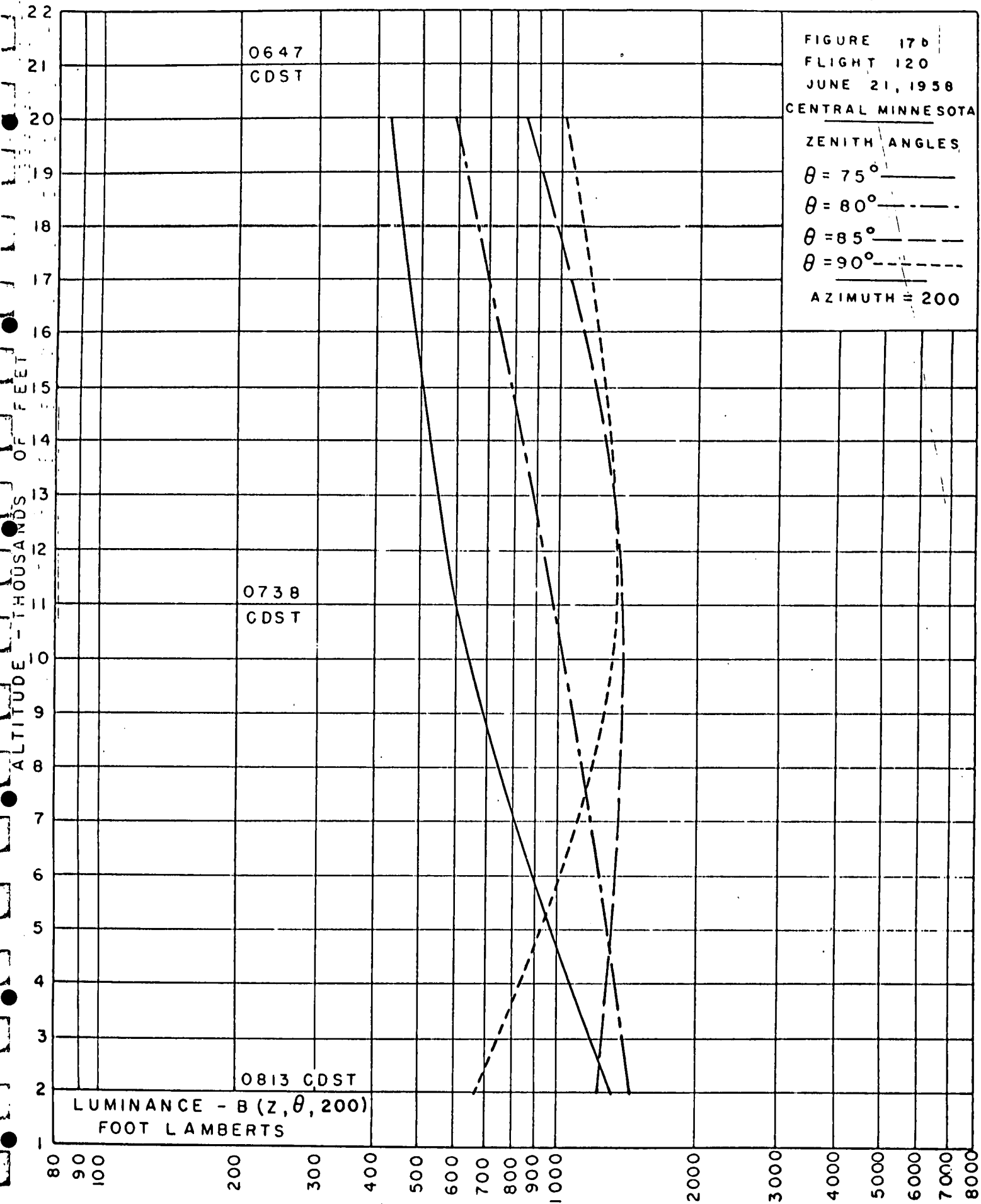


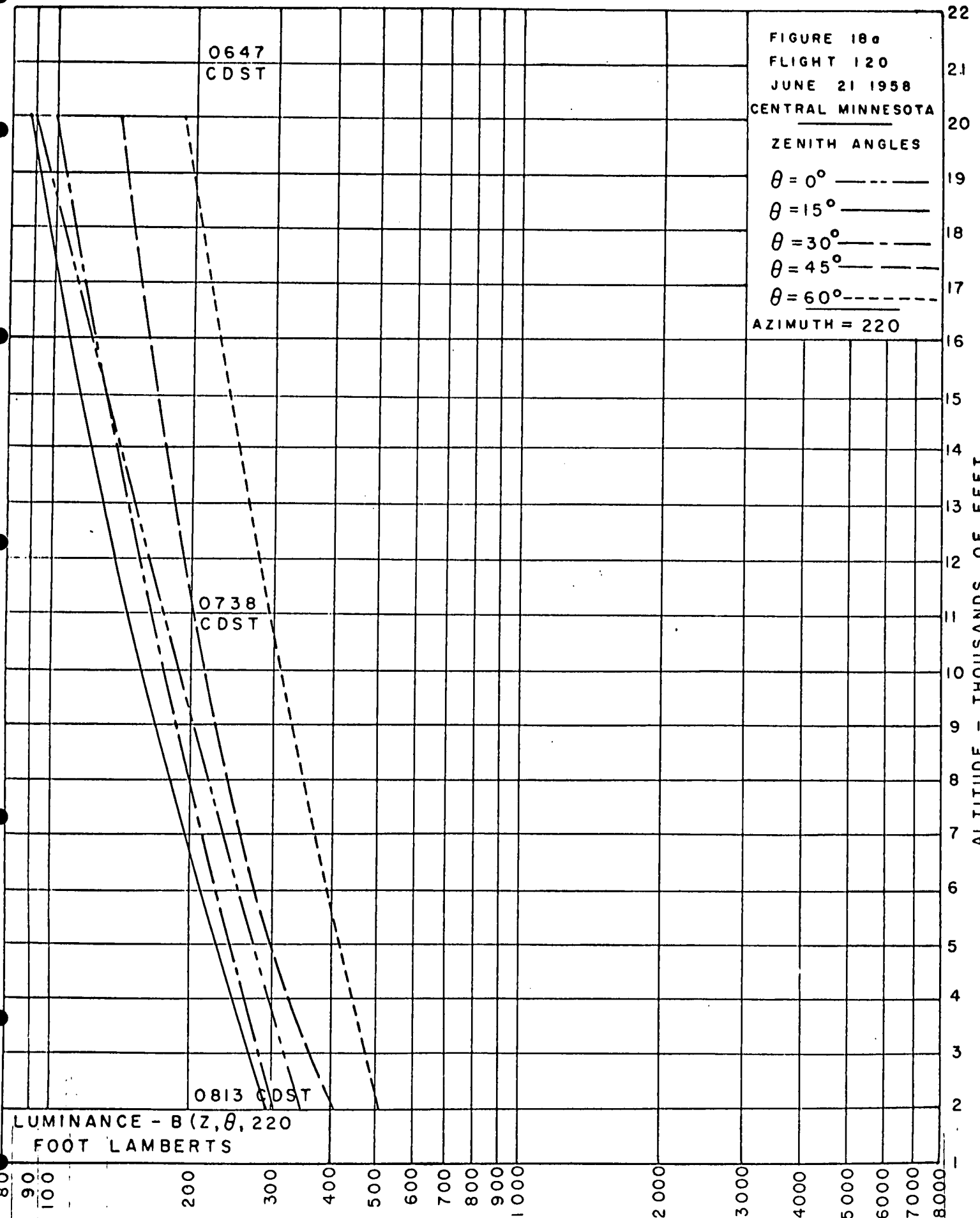


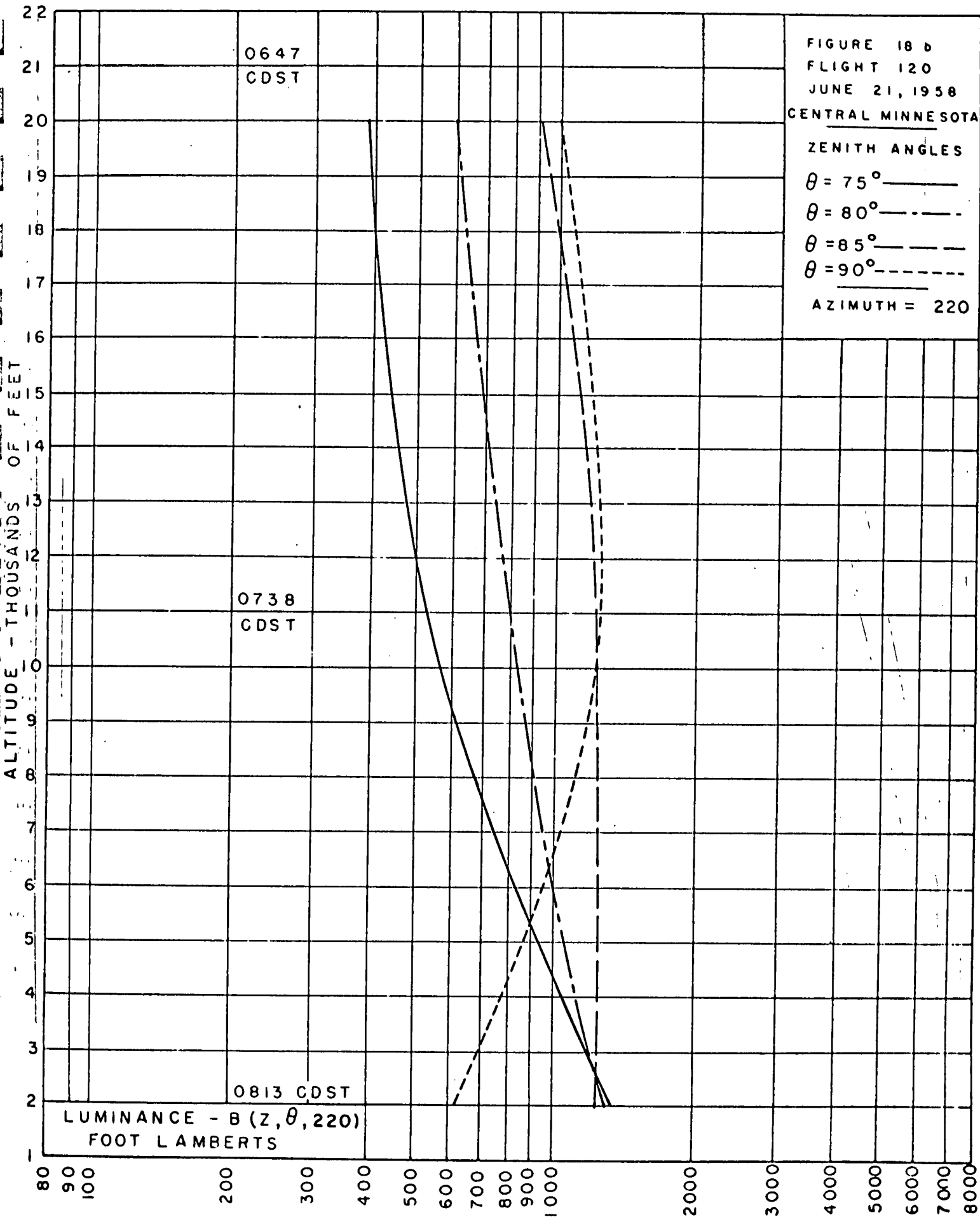


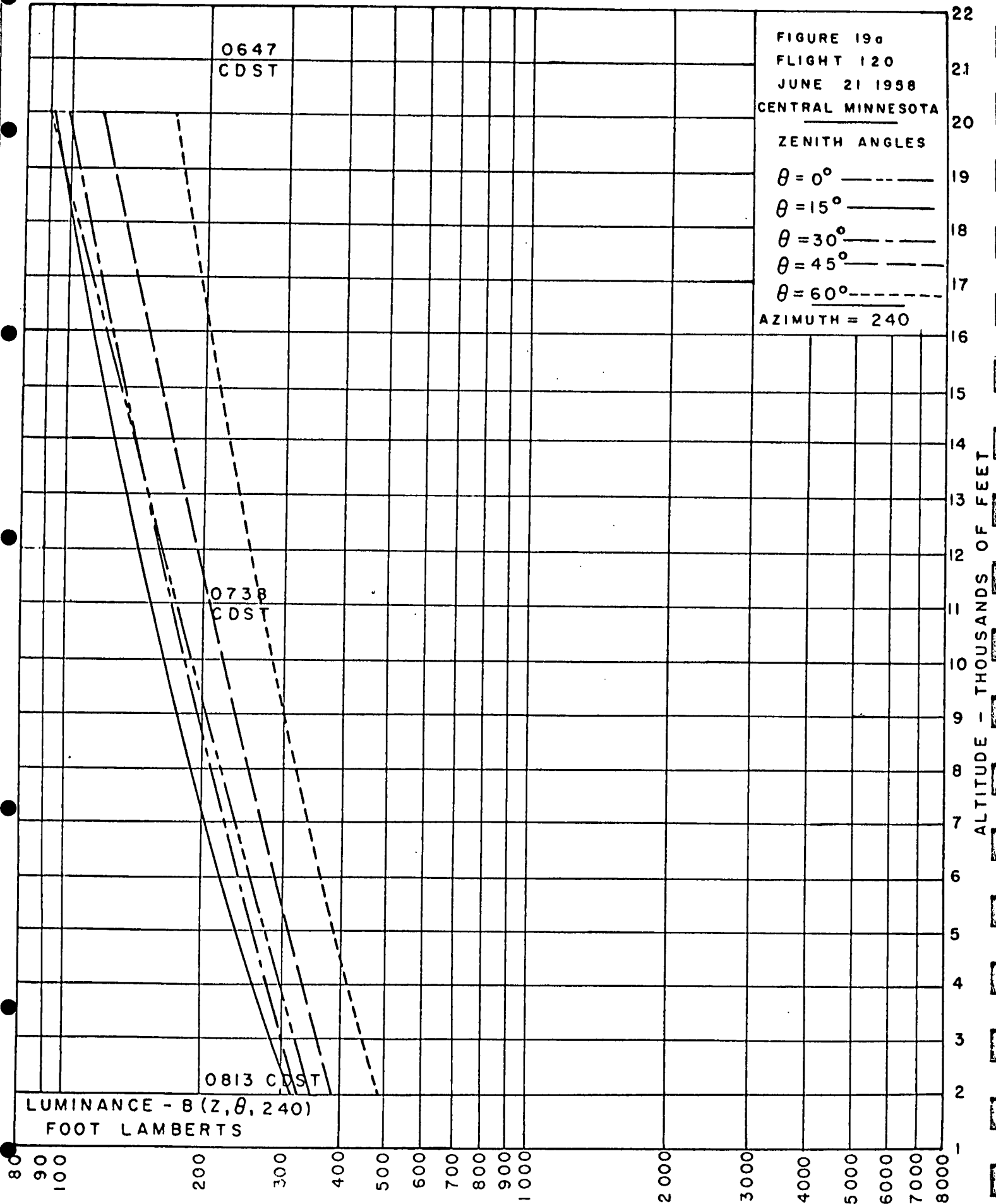


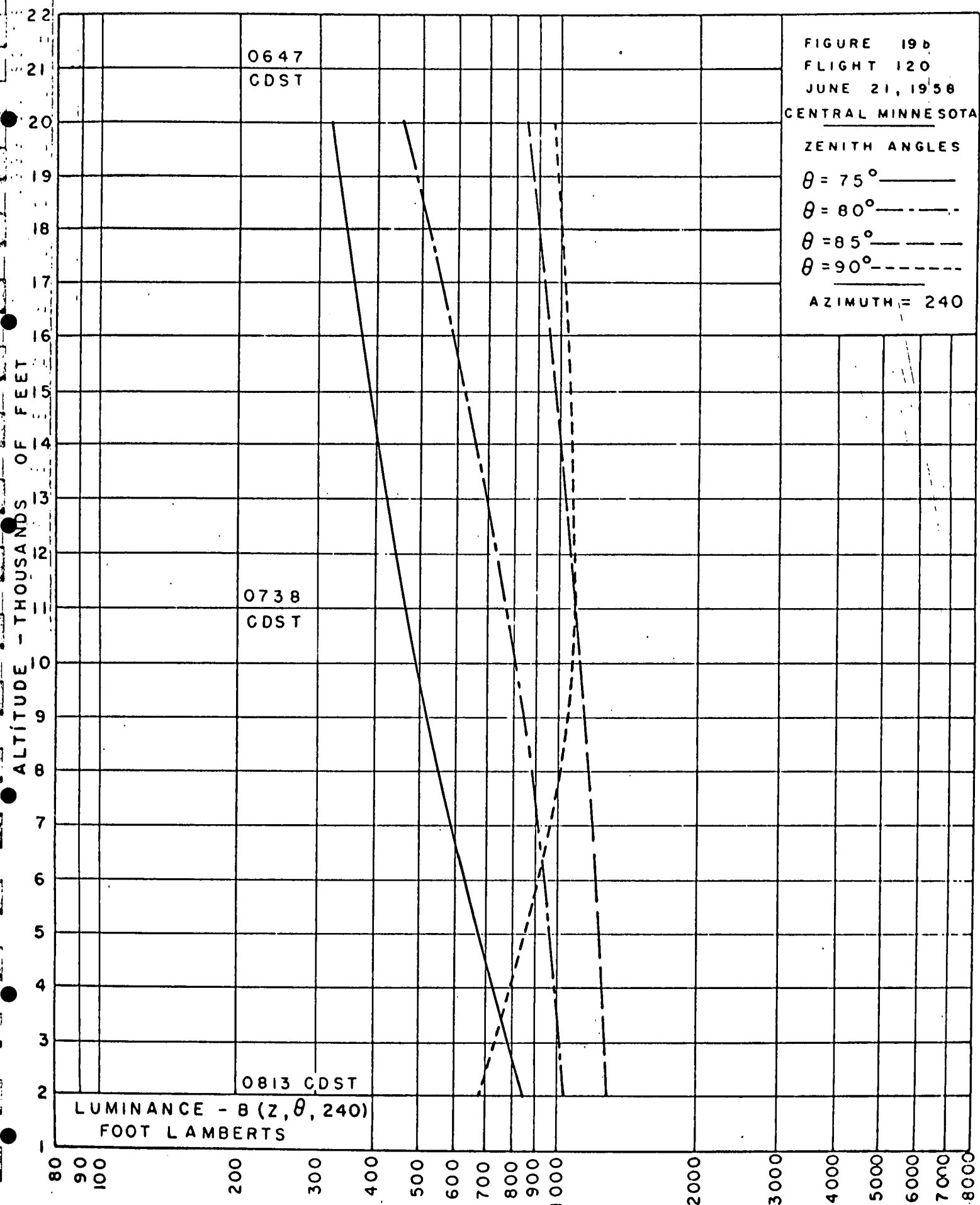


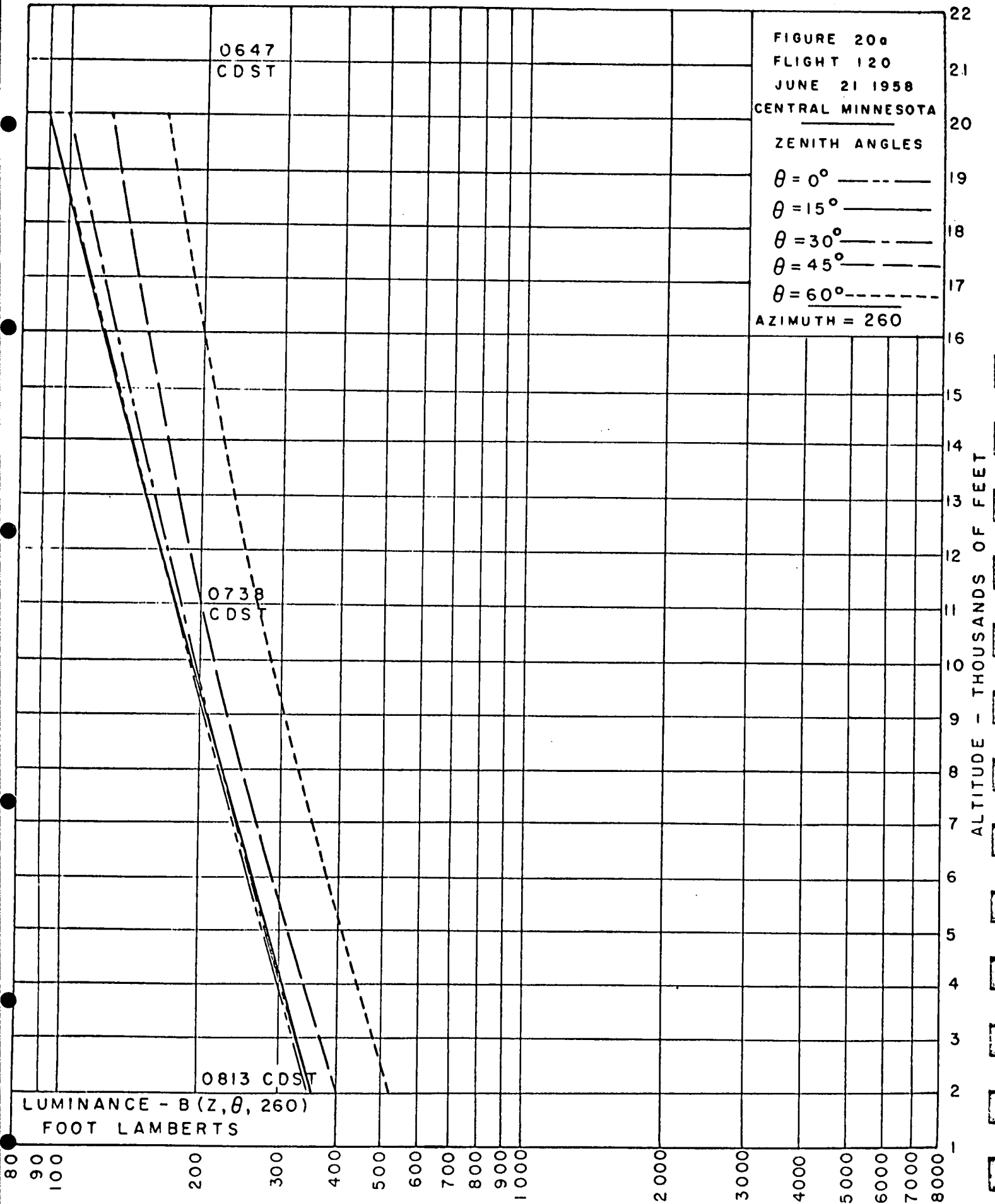


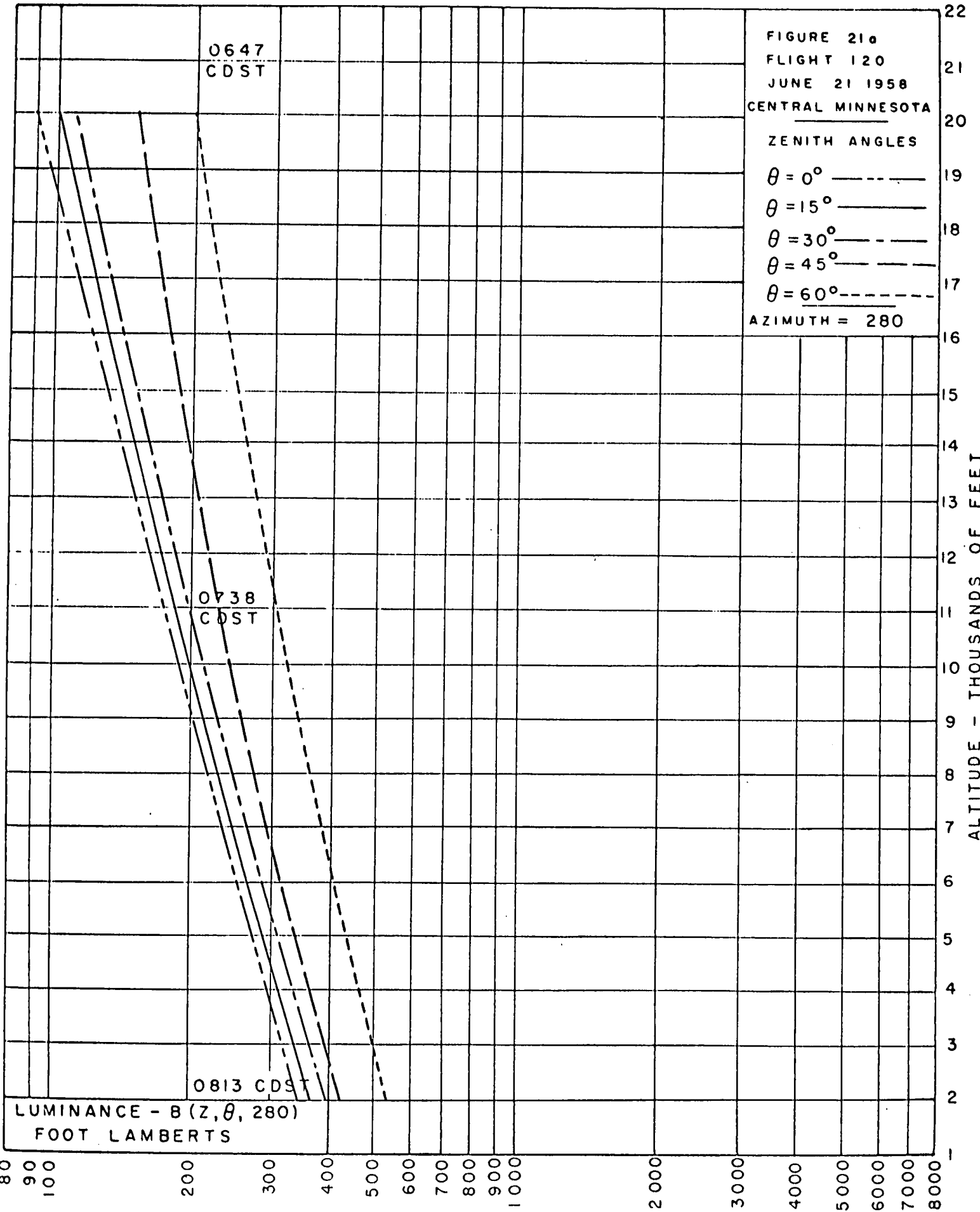


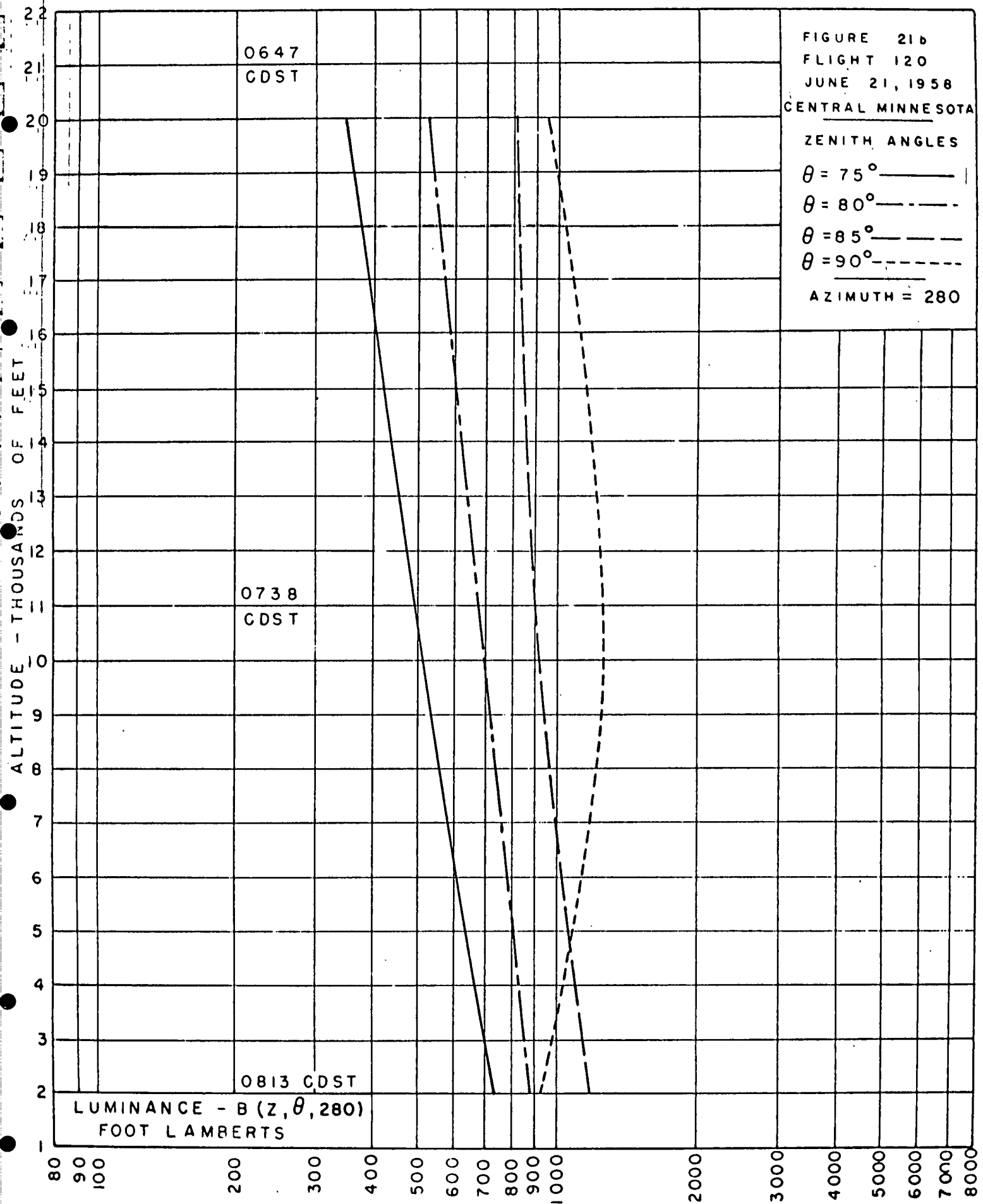


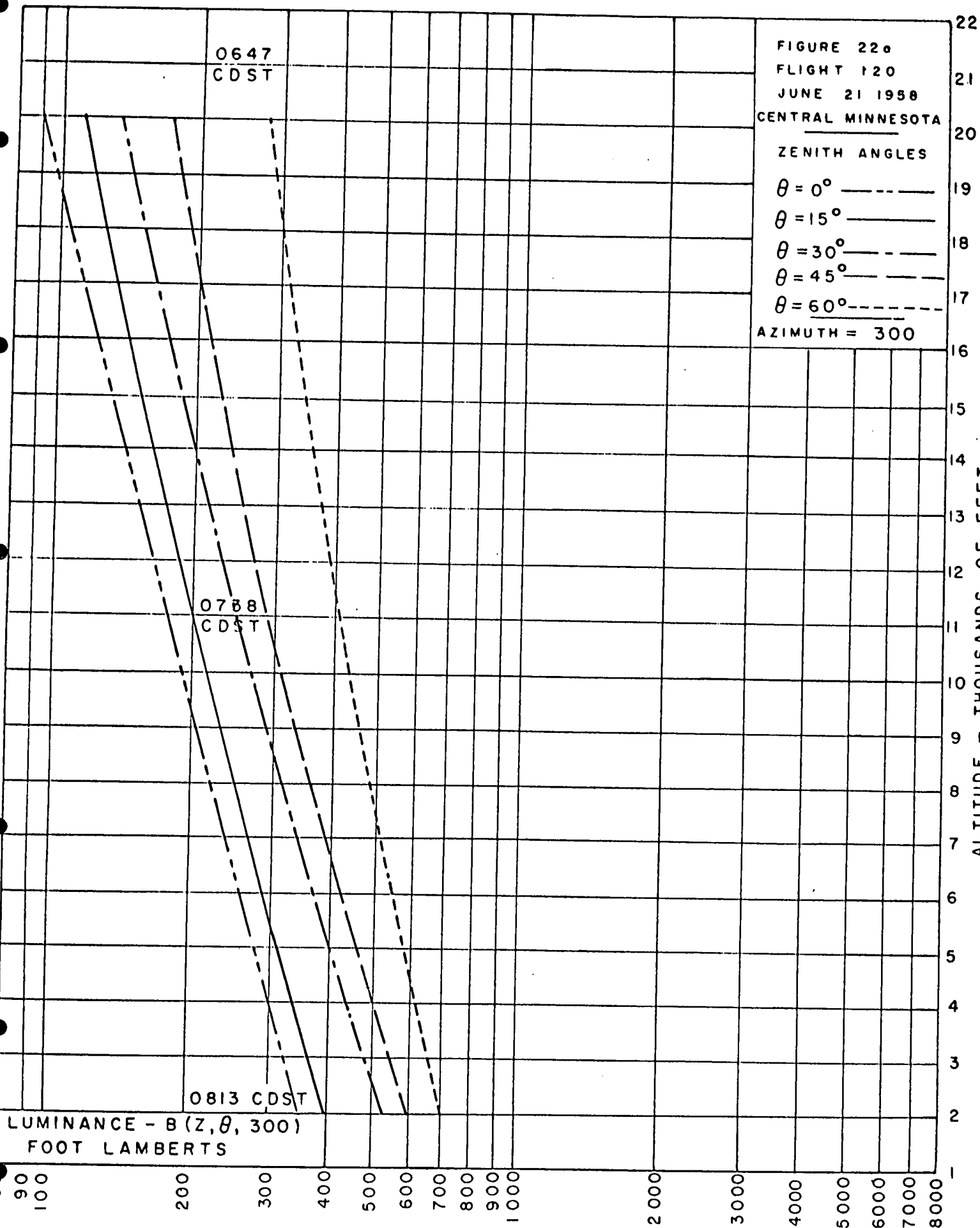












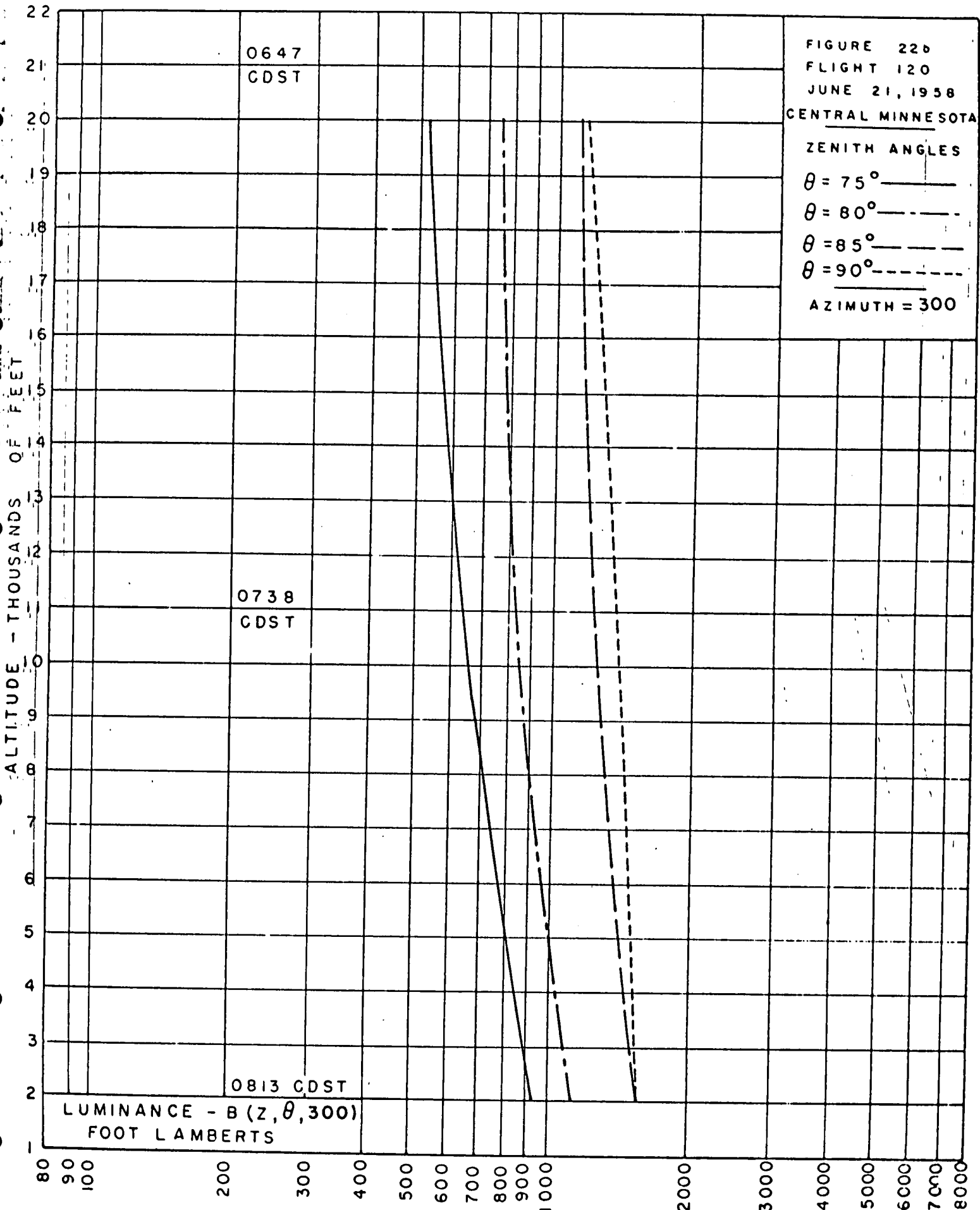
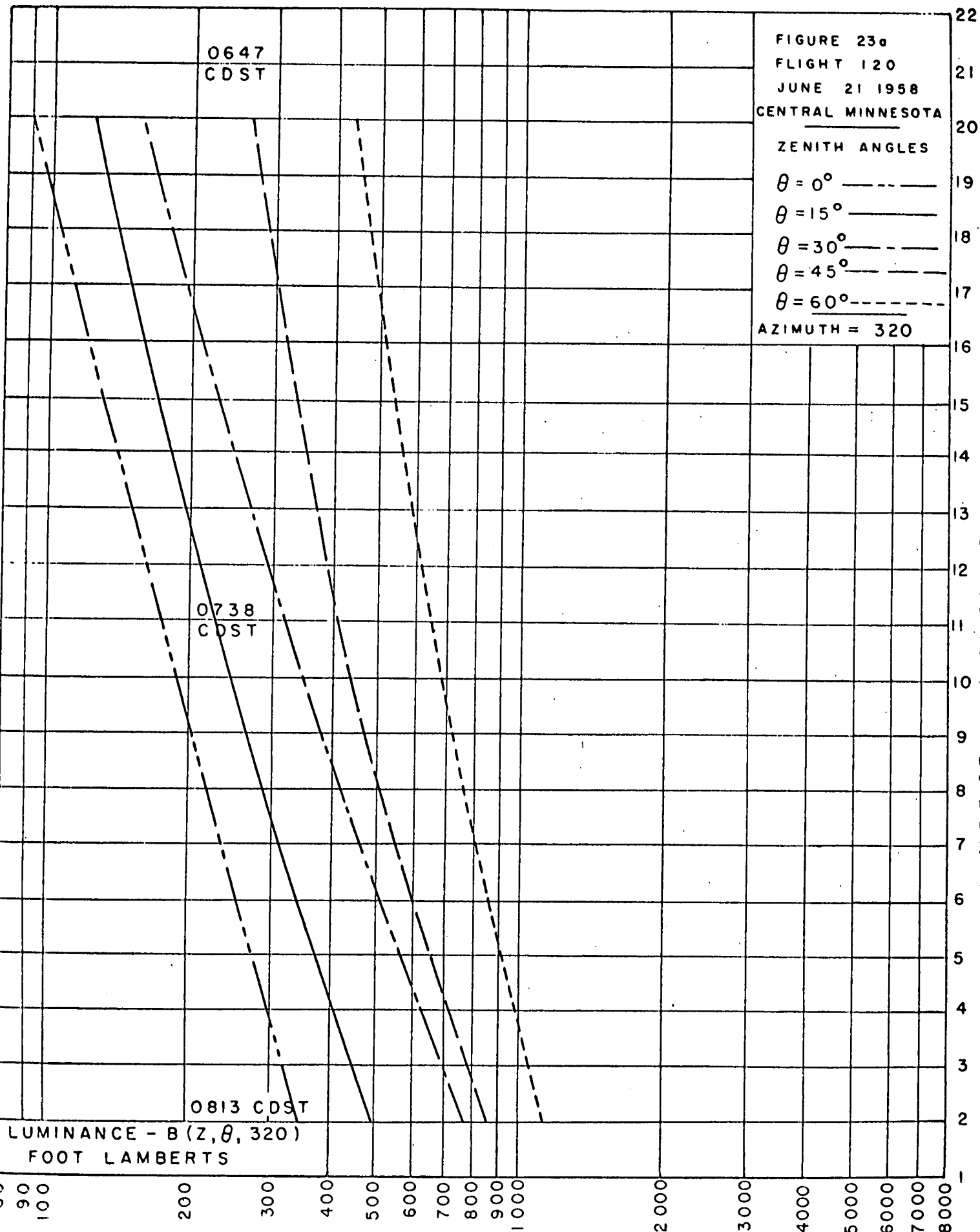


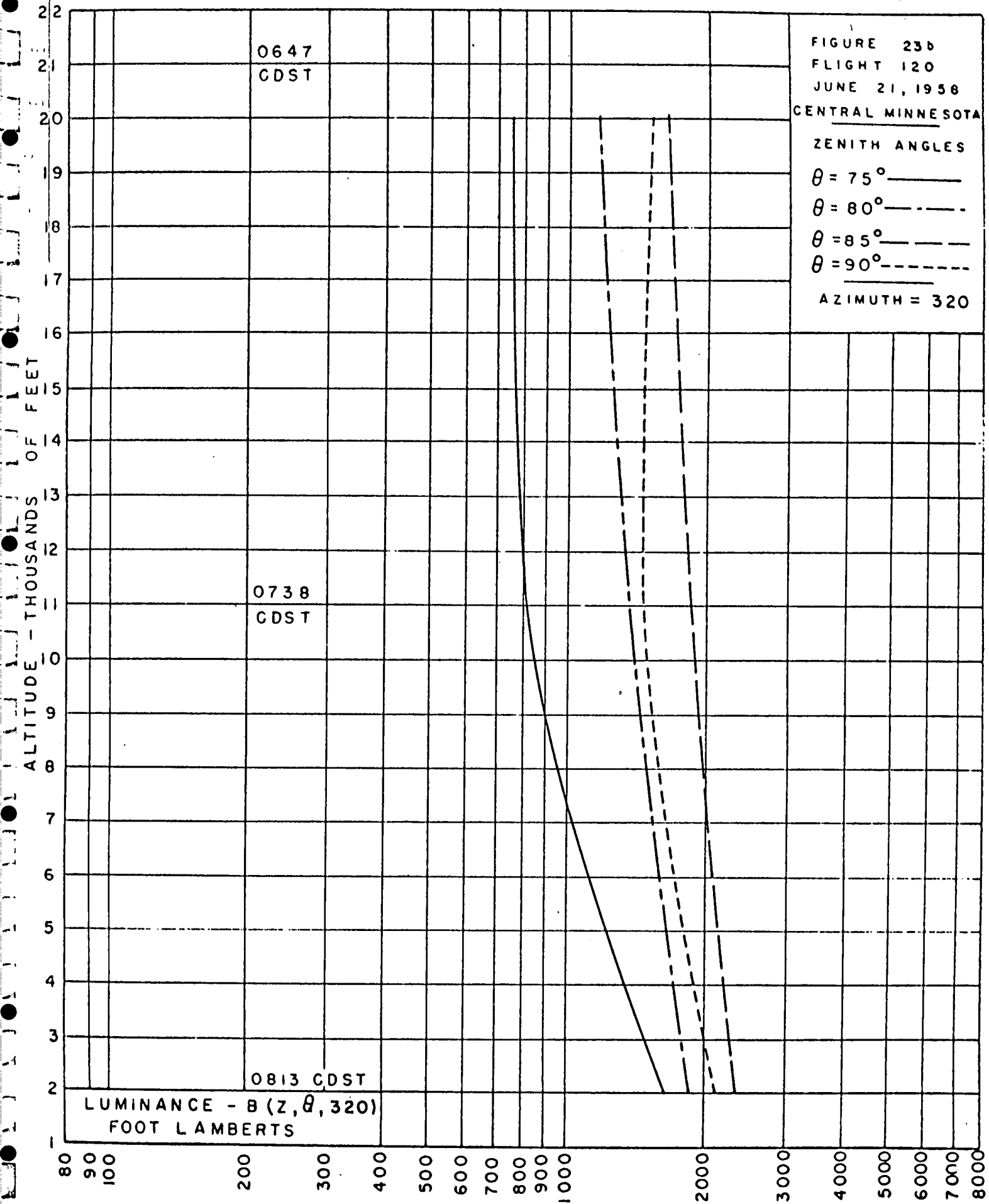
FIGURE 22b
FLIGHT 120
JUNE 21, 1958
CENTRAL MINNESOTA
ZENITH ANGLES
 $\theta = 75^\circ$ ———
 $\theta = 80^\circ$ - - - -
 $\theta = 85^\circ$ - · - · -
 $\theta = 90^\circ$ · · · ·
AZIMUTH = 300

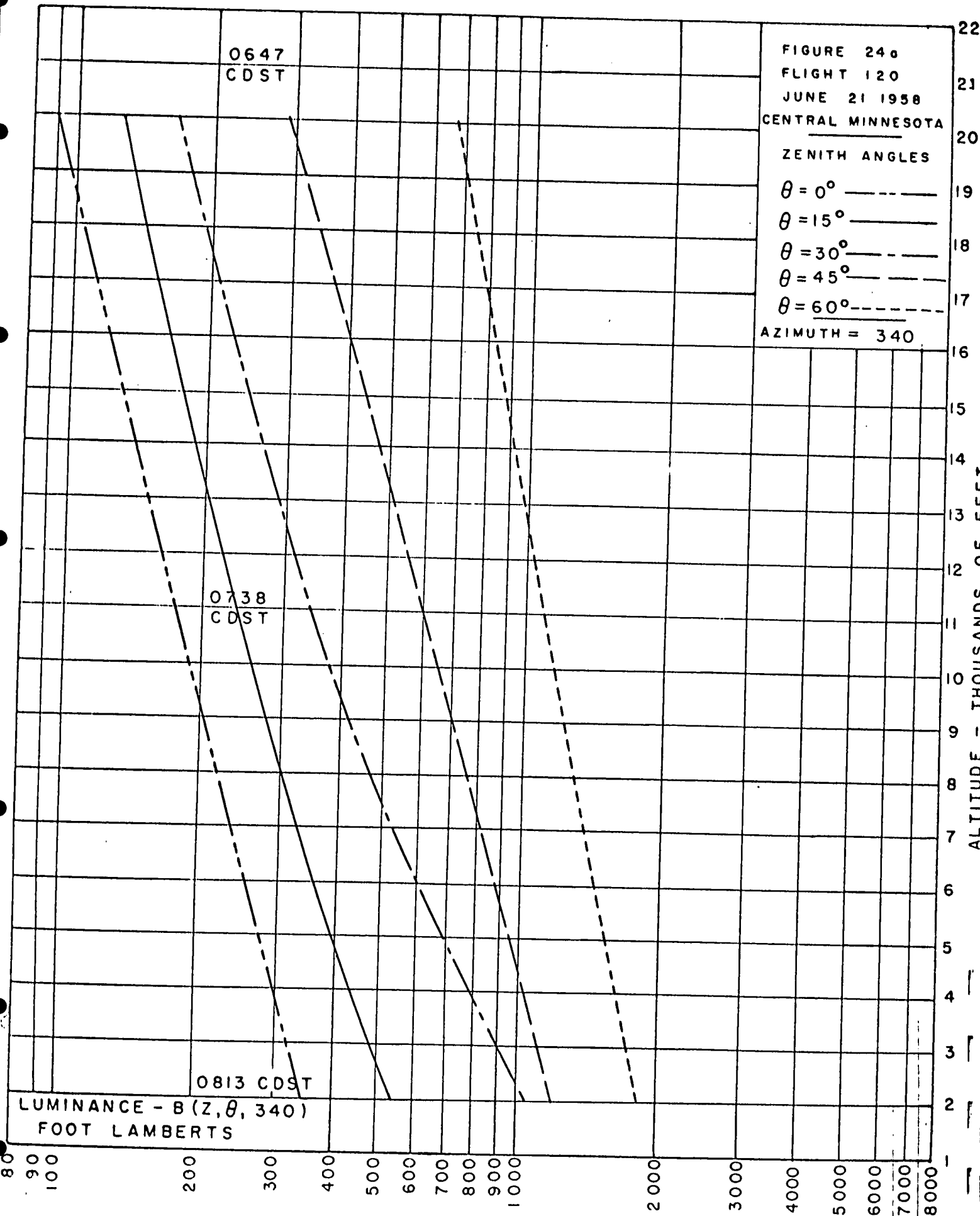
ALTITUDE - THOUSANDS OF FEET

LUMINANCE - $B(z, \theta, 300)$
FOOT LAMBERTS

80 90 100 200 300 400 500 600 700 800 900 1000 2000 3000 4000 5000 6000 7000 8000







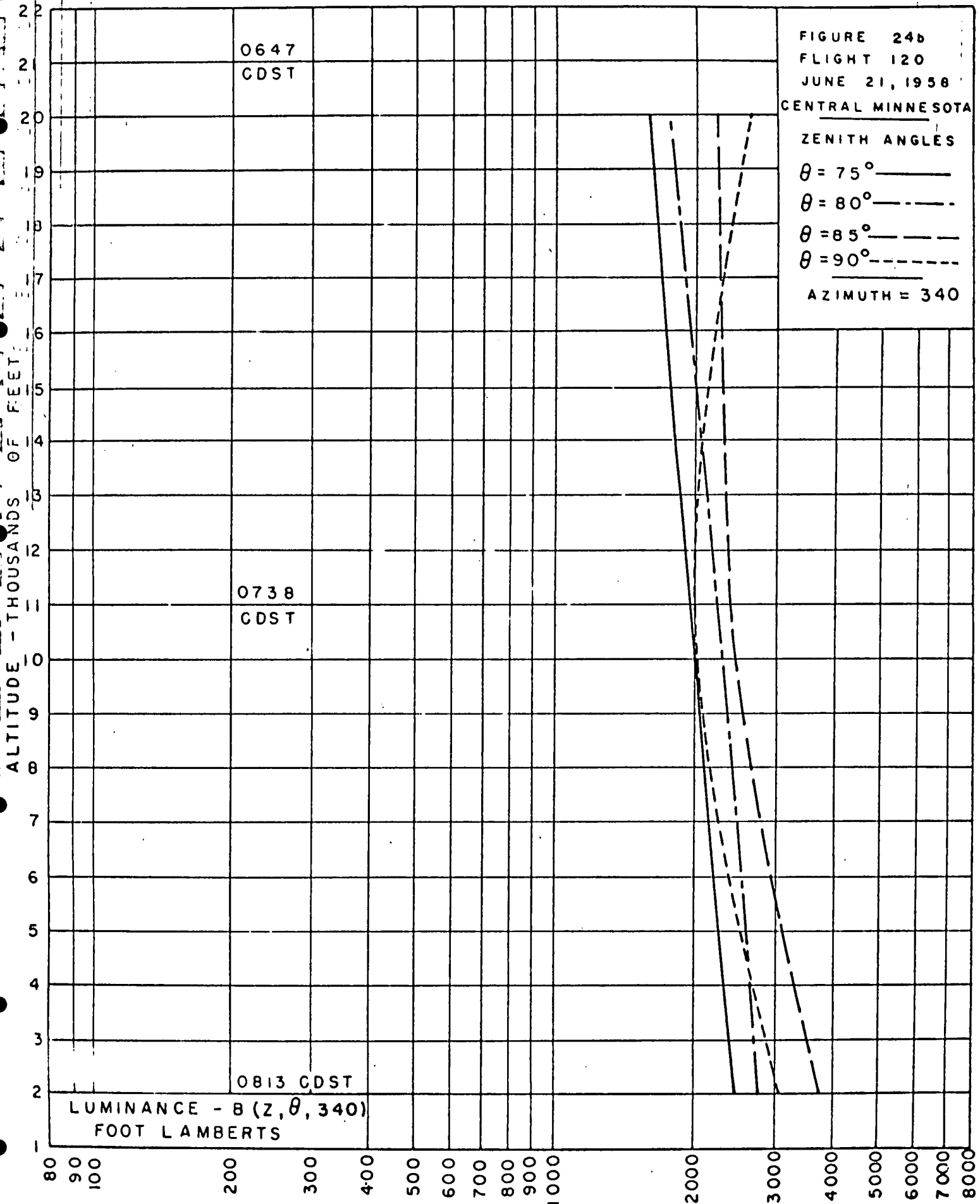


FIGURE 24b
FLIGHT 120
JUNE 21, 1958
CENTRAL MINNESOTA
ZENITH ANGLES
 $\theta = 75^\circ$ ———
 $\theta = 80^\circ$ - - - -
 $\theta = 85^\circ$ - - - -
 $\theta = 90^\circ$ - - - -
AZIMUTH = 340

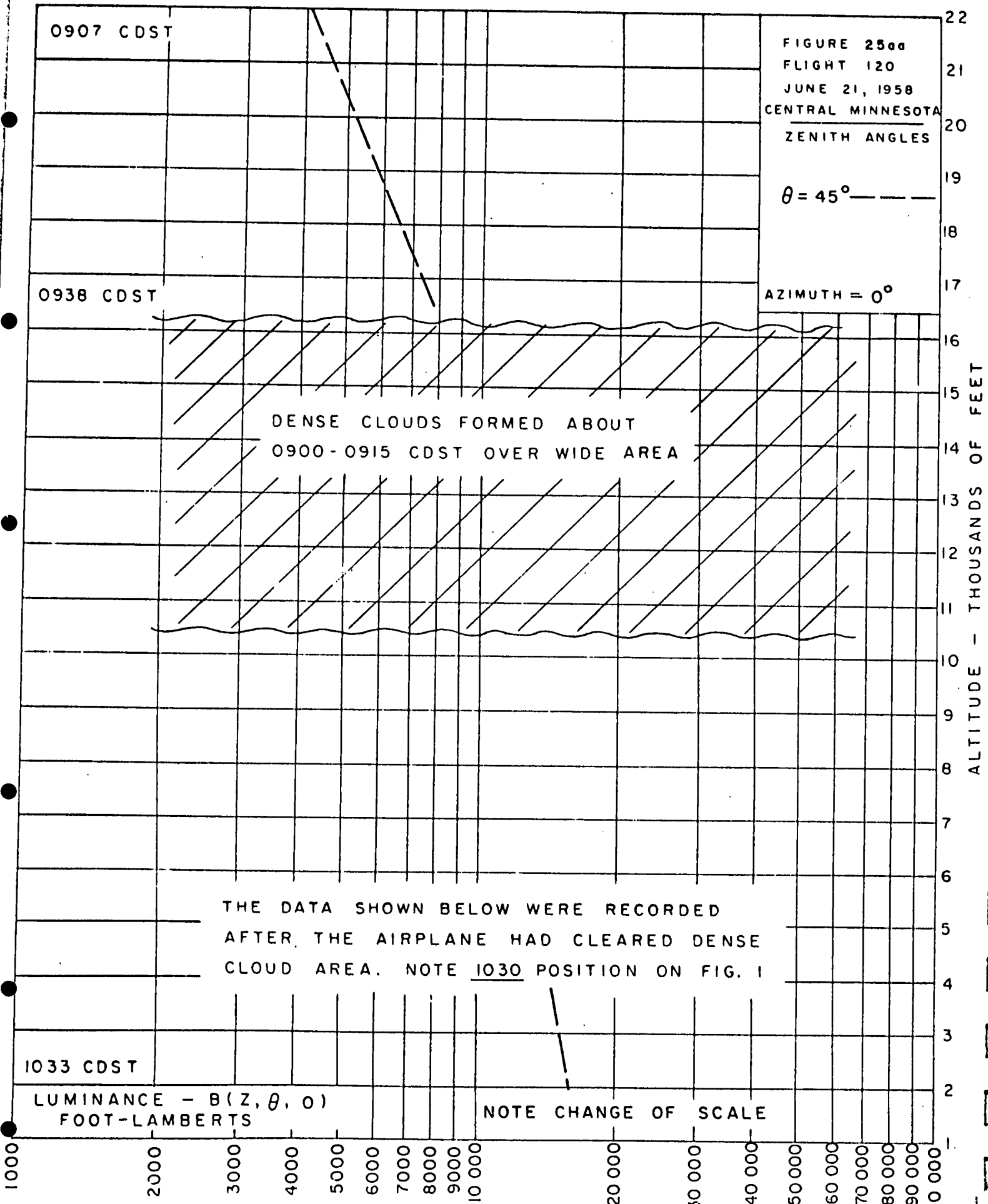
0647
CDST

0738
CDST

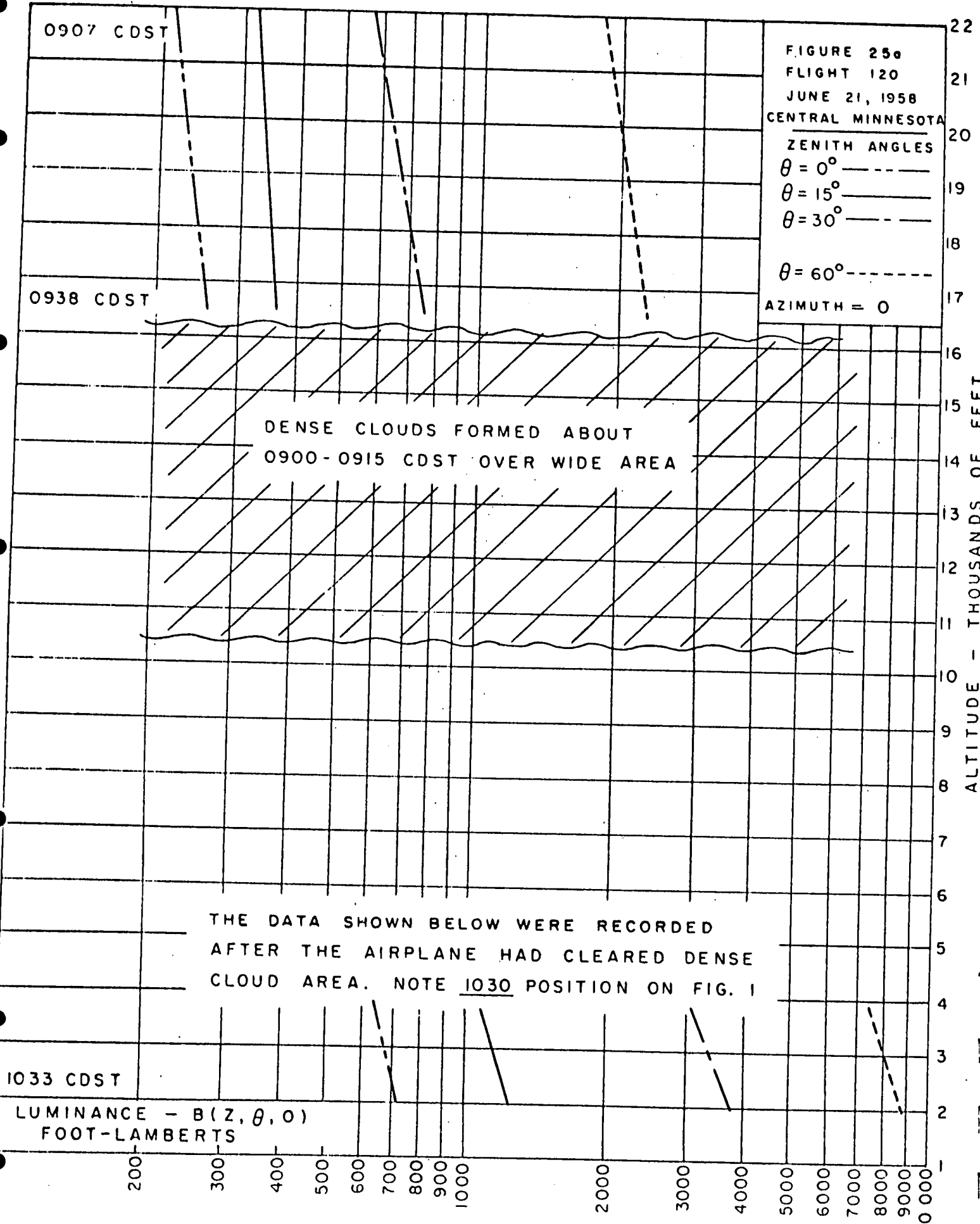
0813 CDST

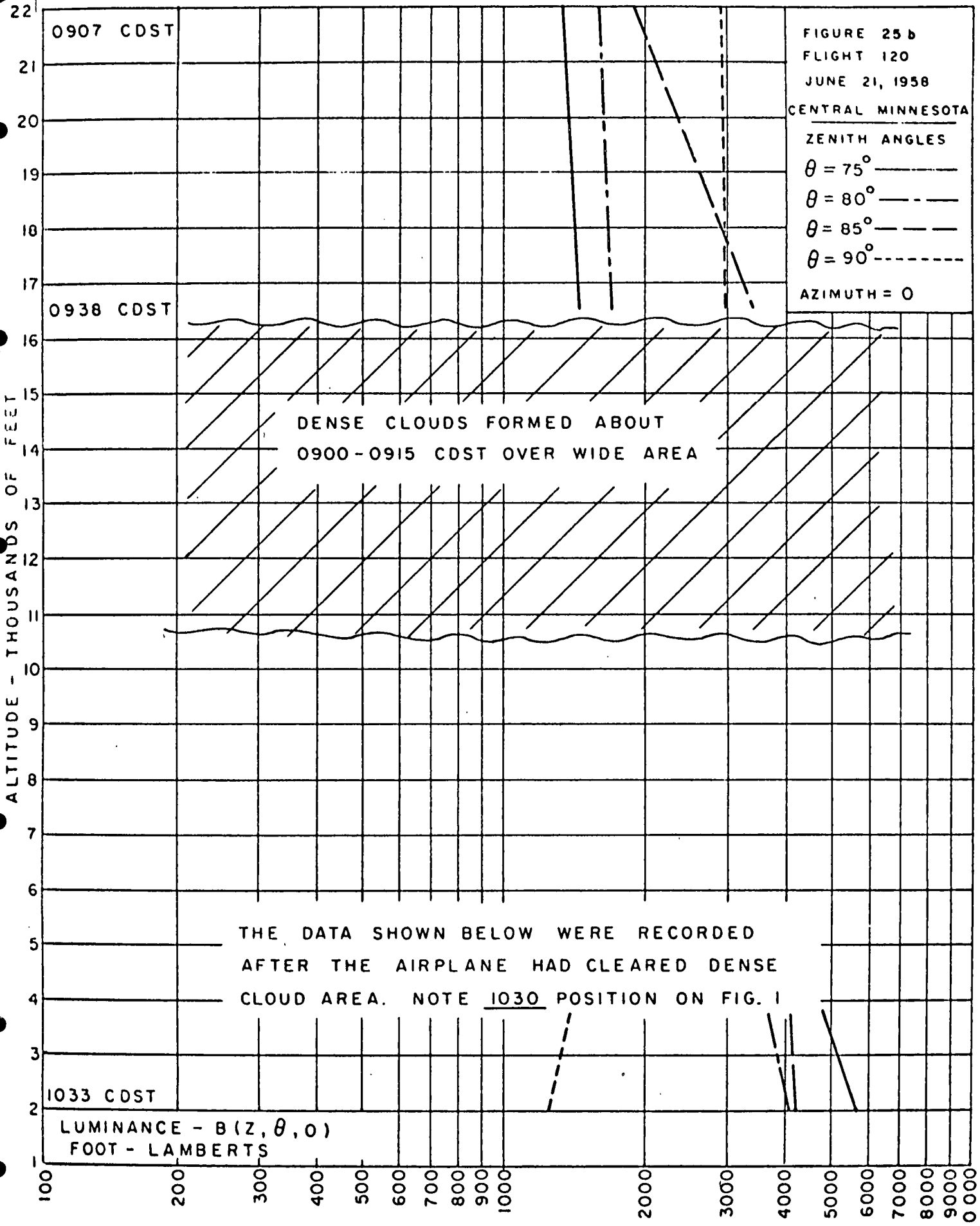
LUMINANCE - $B(Z, \theta, 340)$
FOOT LAMBERTS

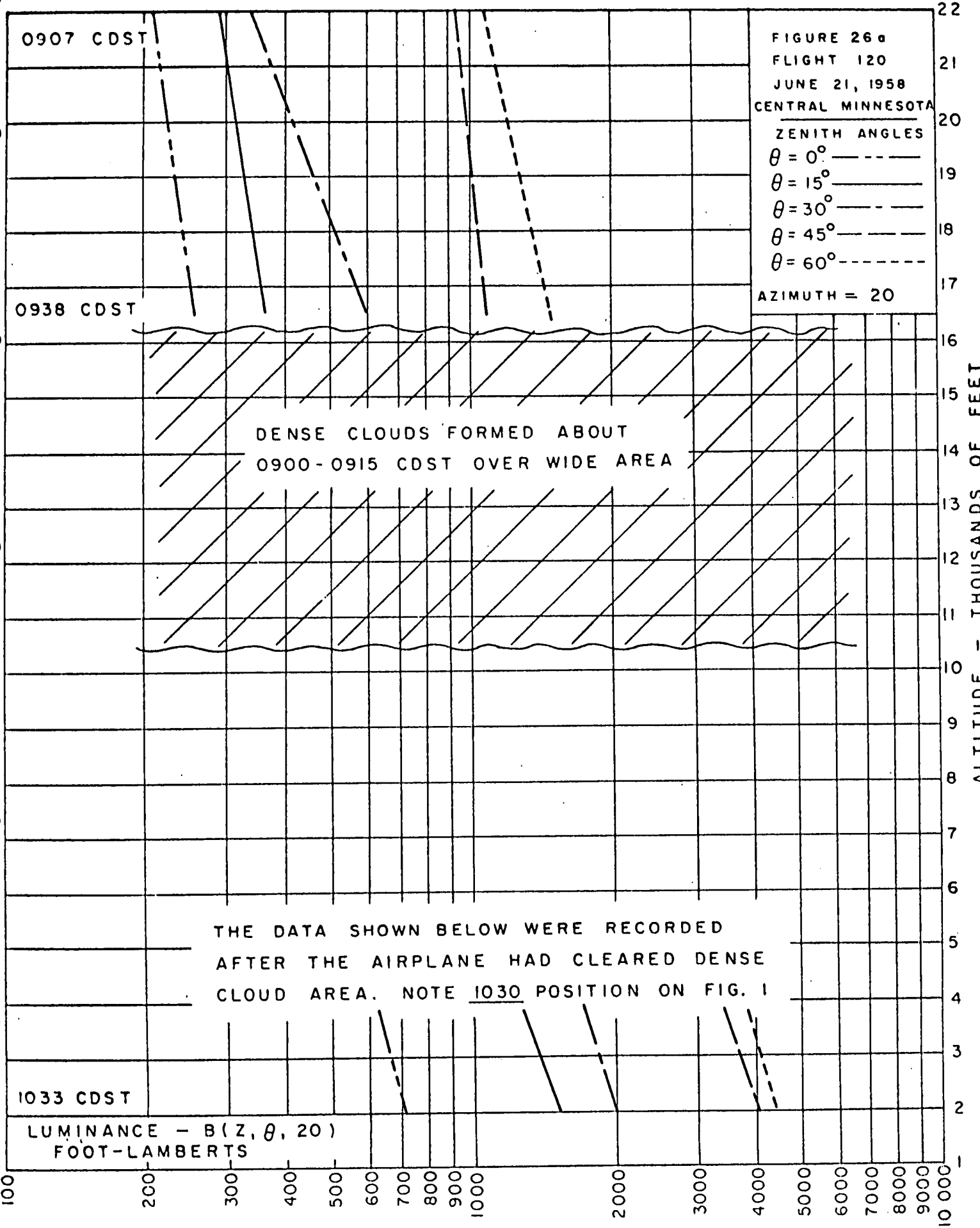
ALTITUDE - THOUSANDS OF FEET

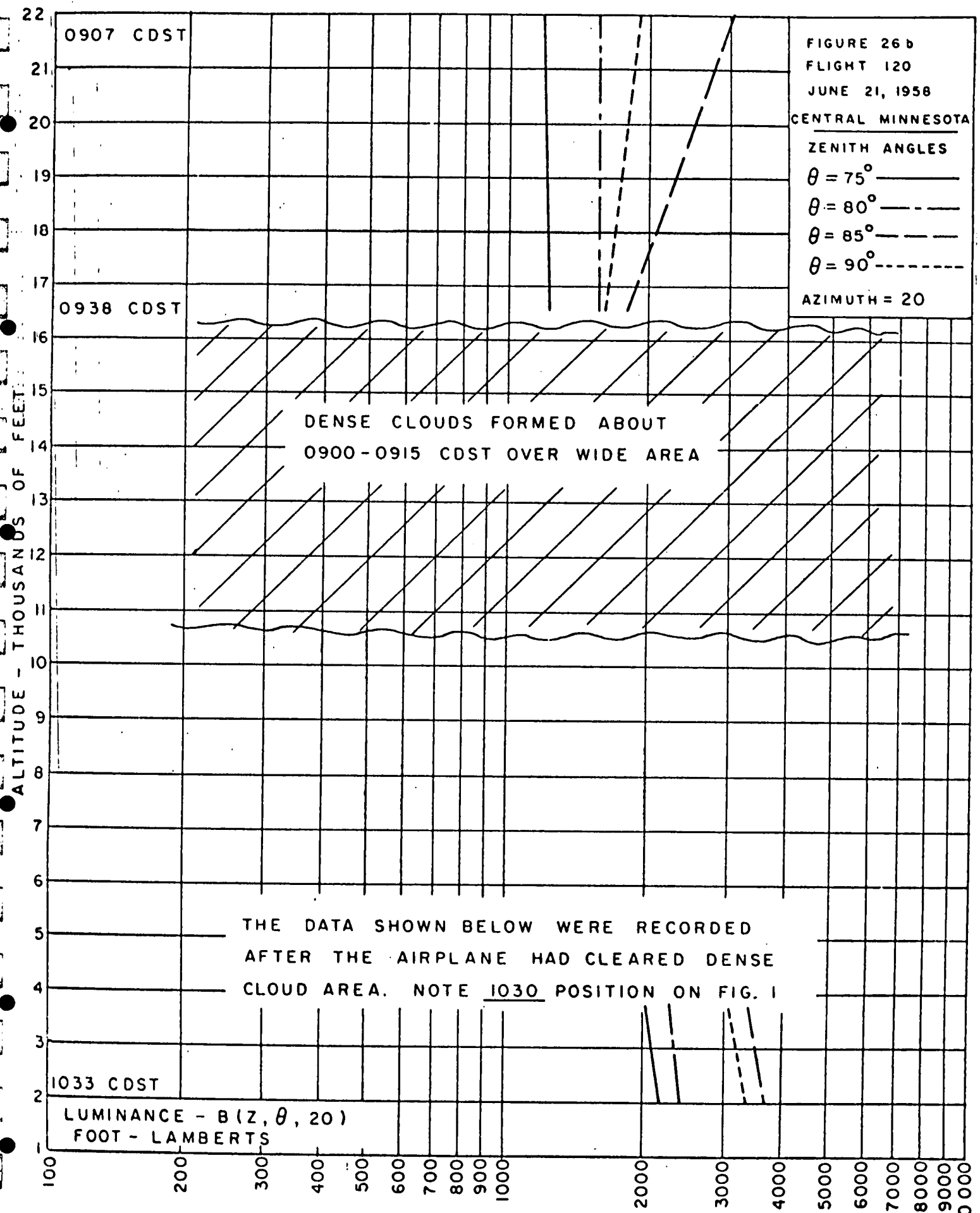


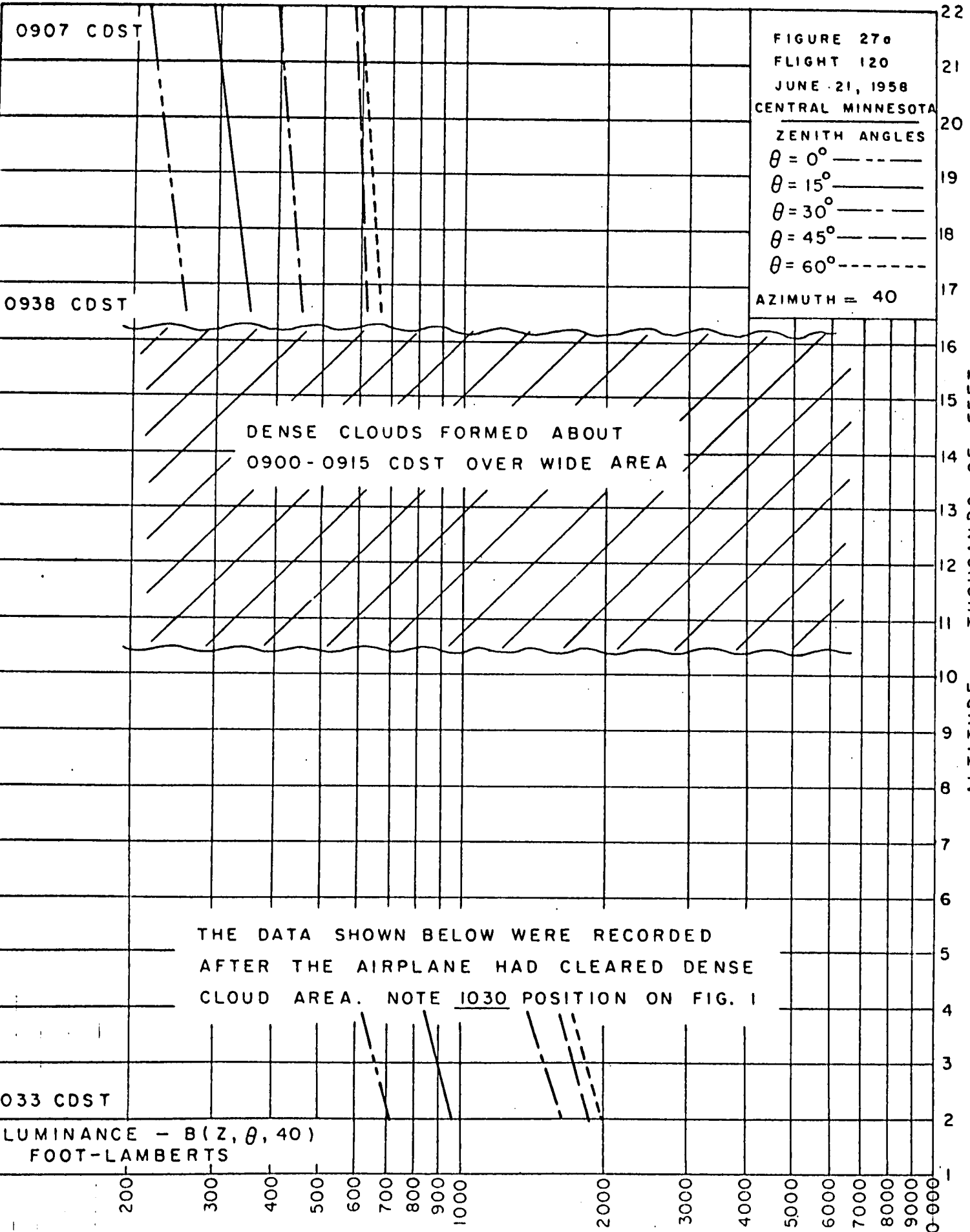
The remarks on page 21 concerning Fig. 7aa apply in the case of Fig. 25aa also. In order to keep the pattern for the abscissa values to two orders of magnitude it is necessary for the 0° azimuth 45° zenith angle plot to be placed on a separate sheet.

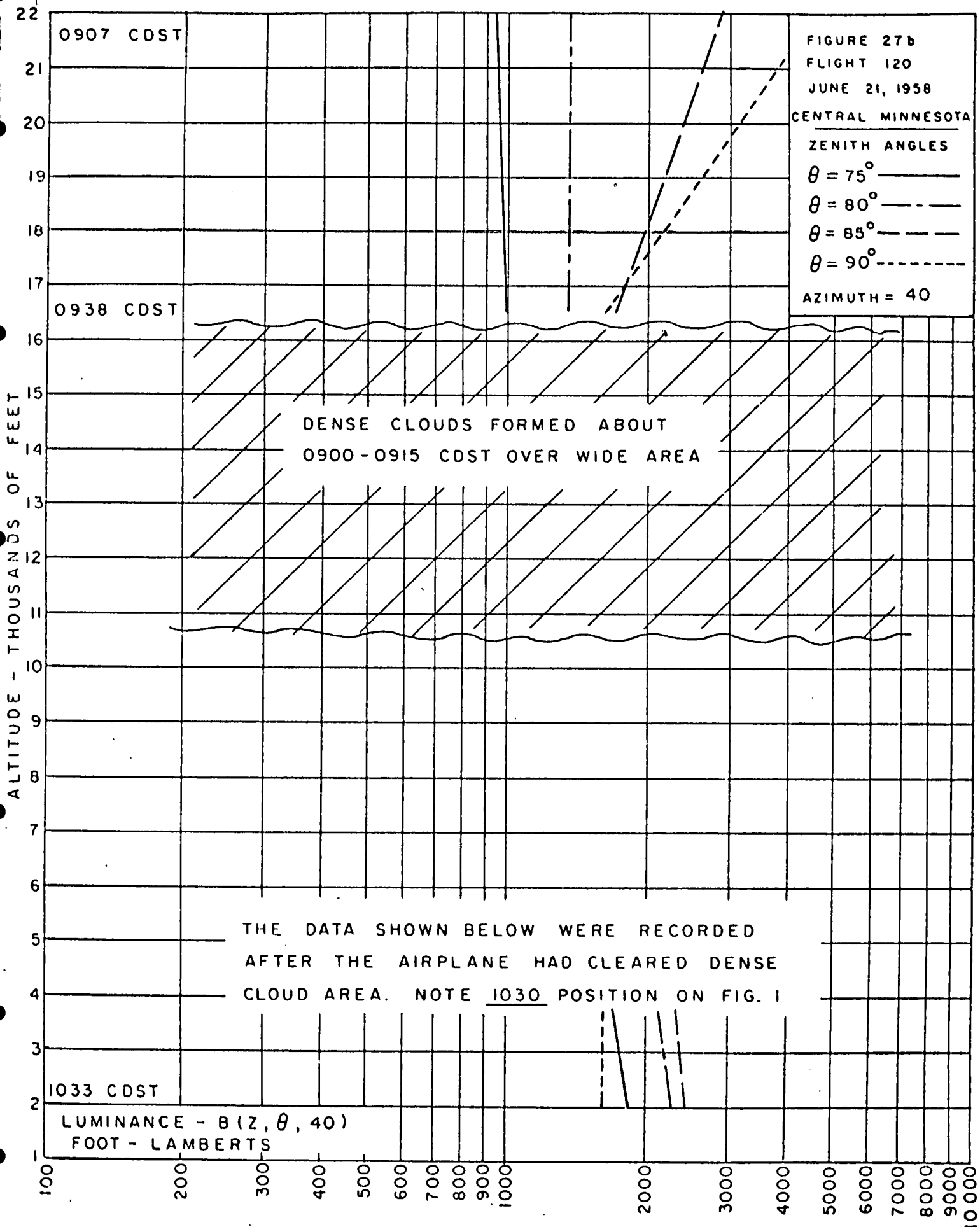


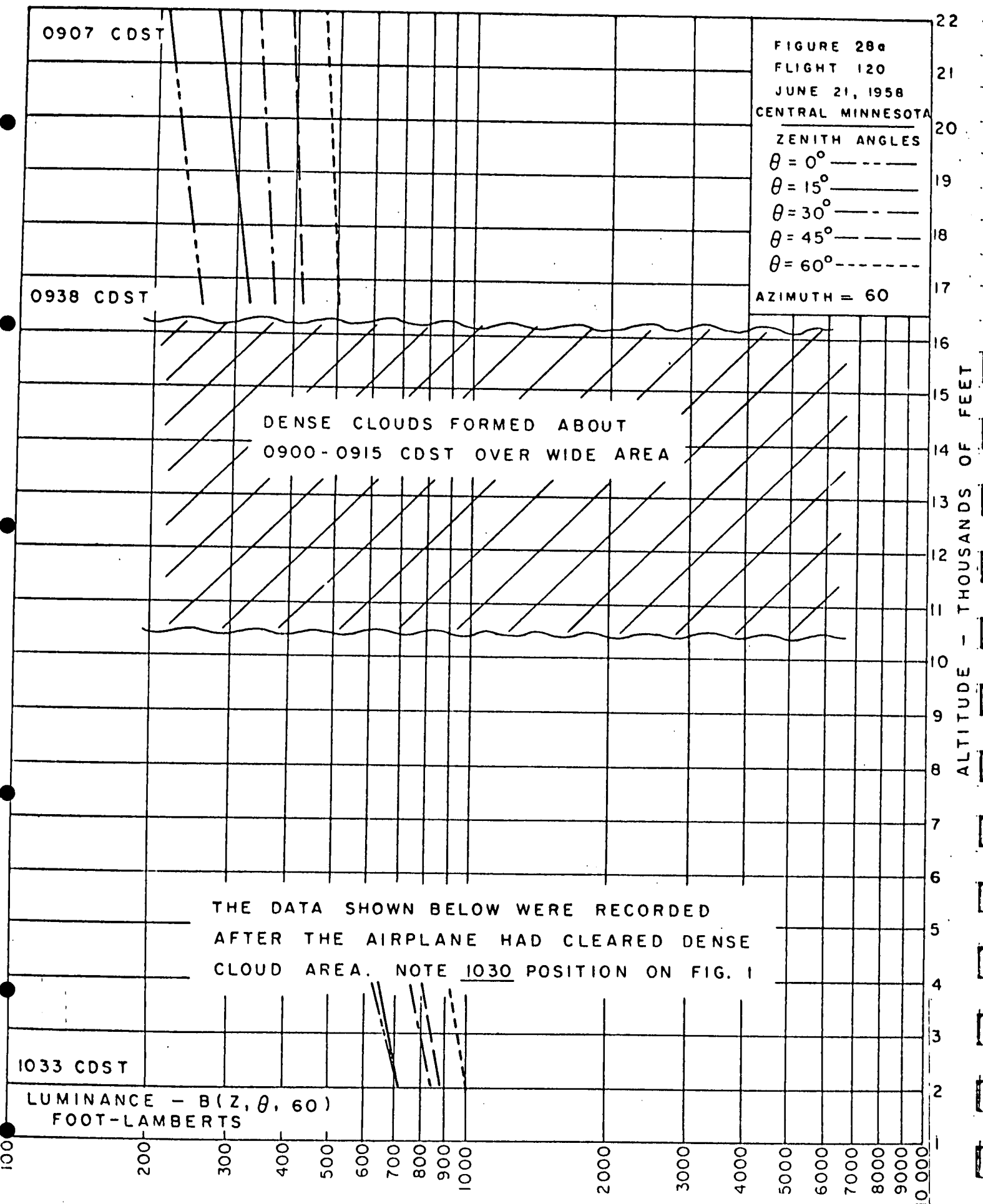


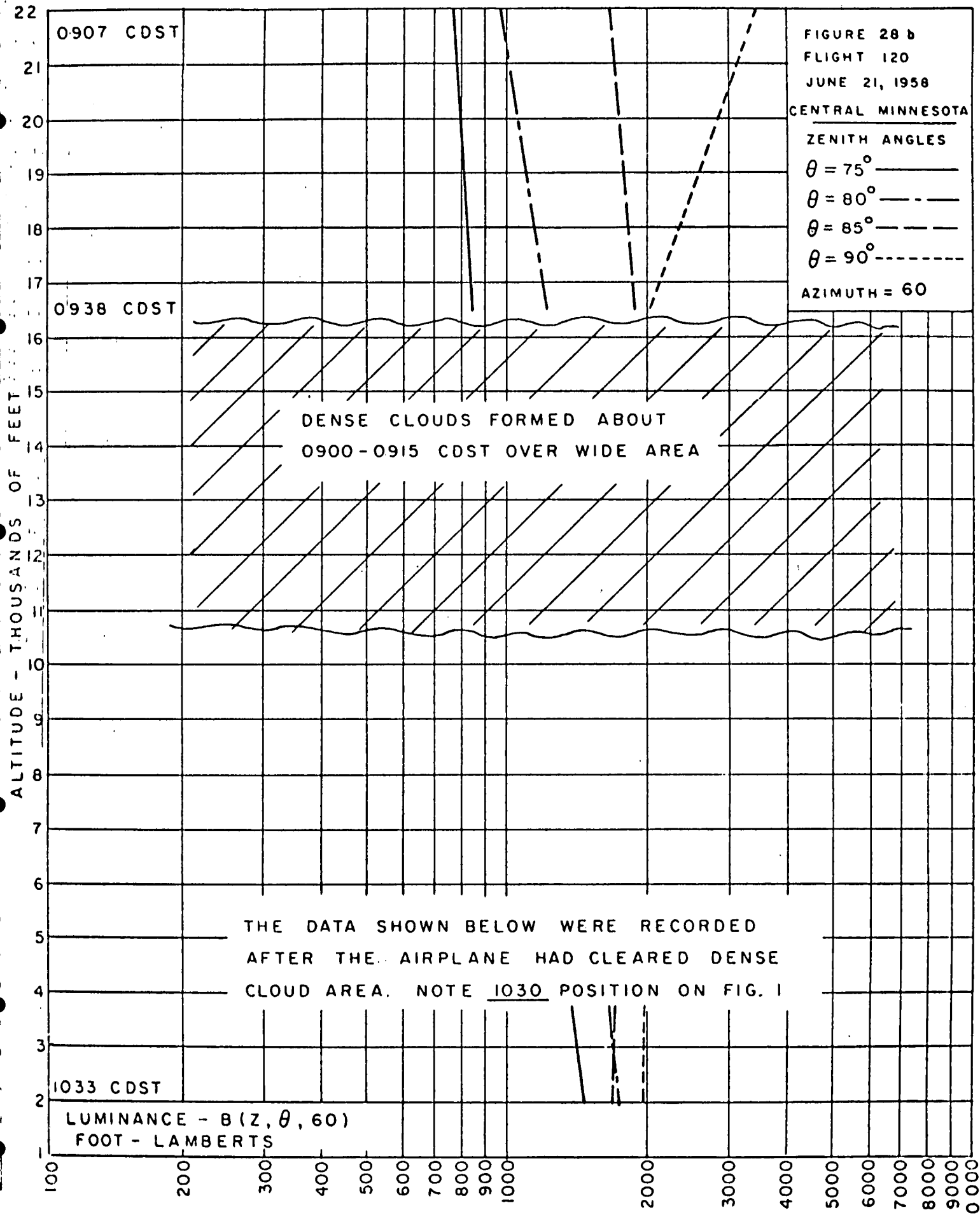


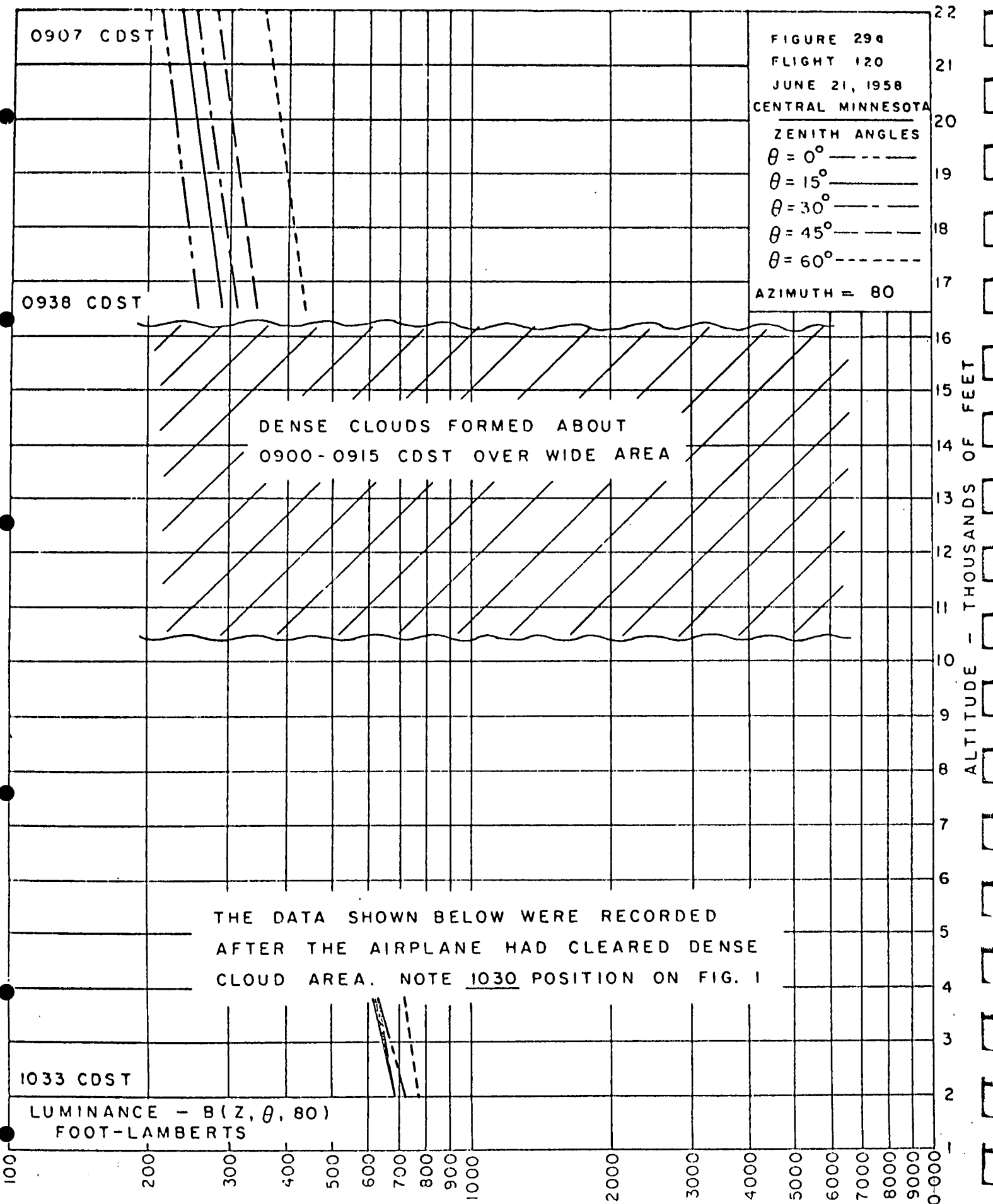


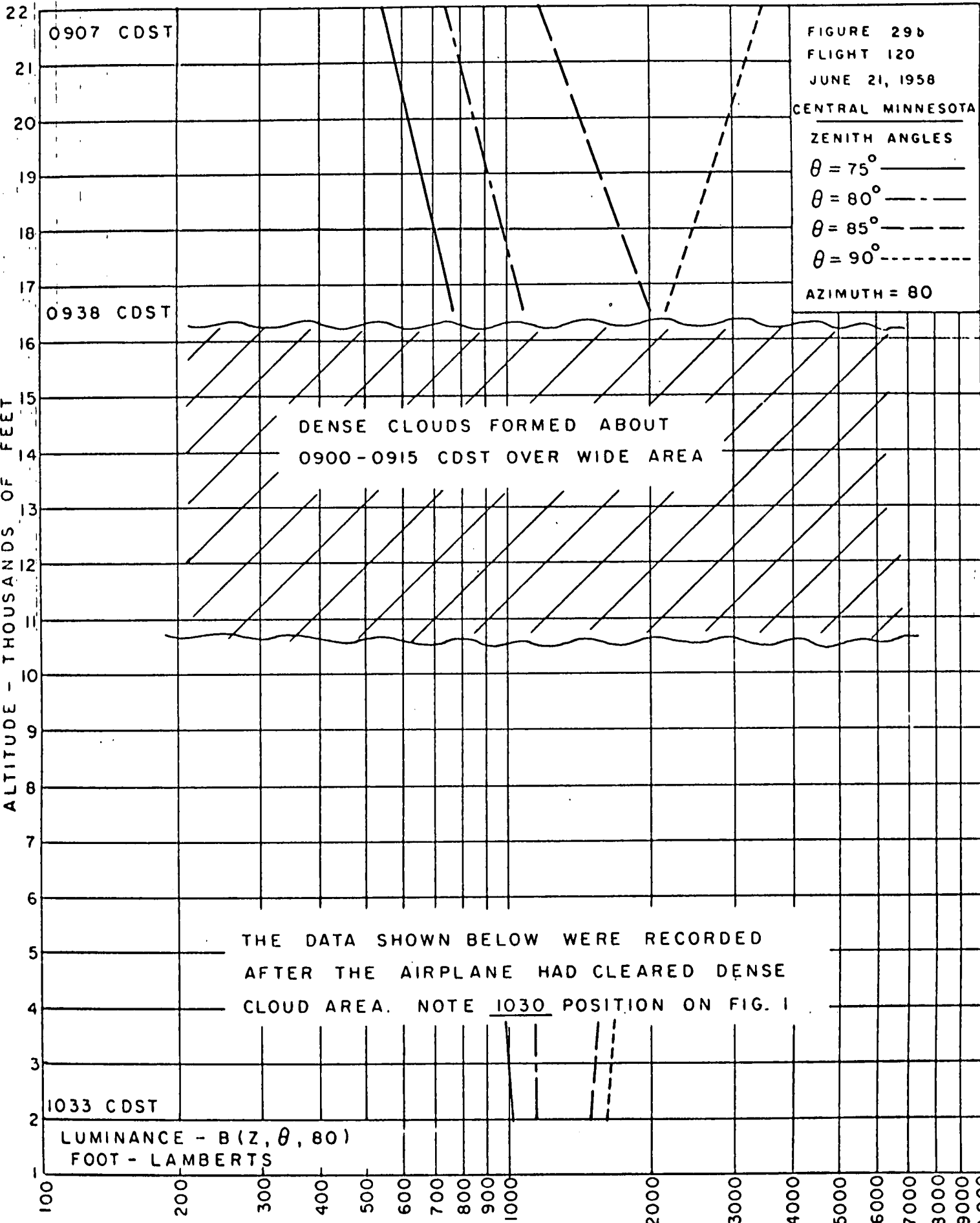


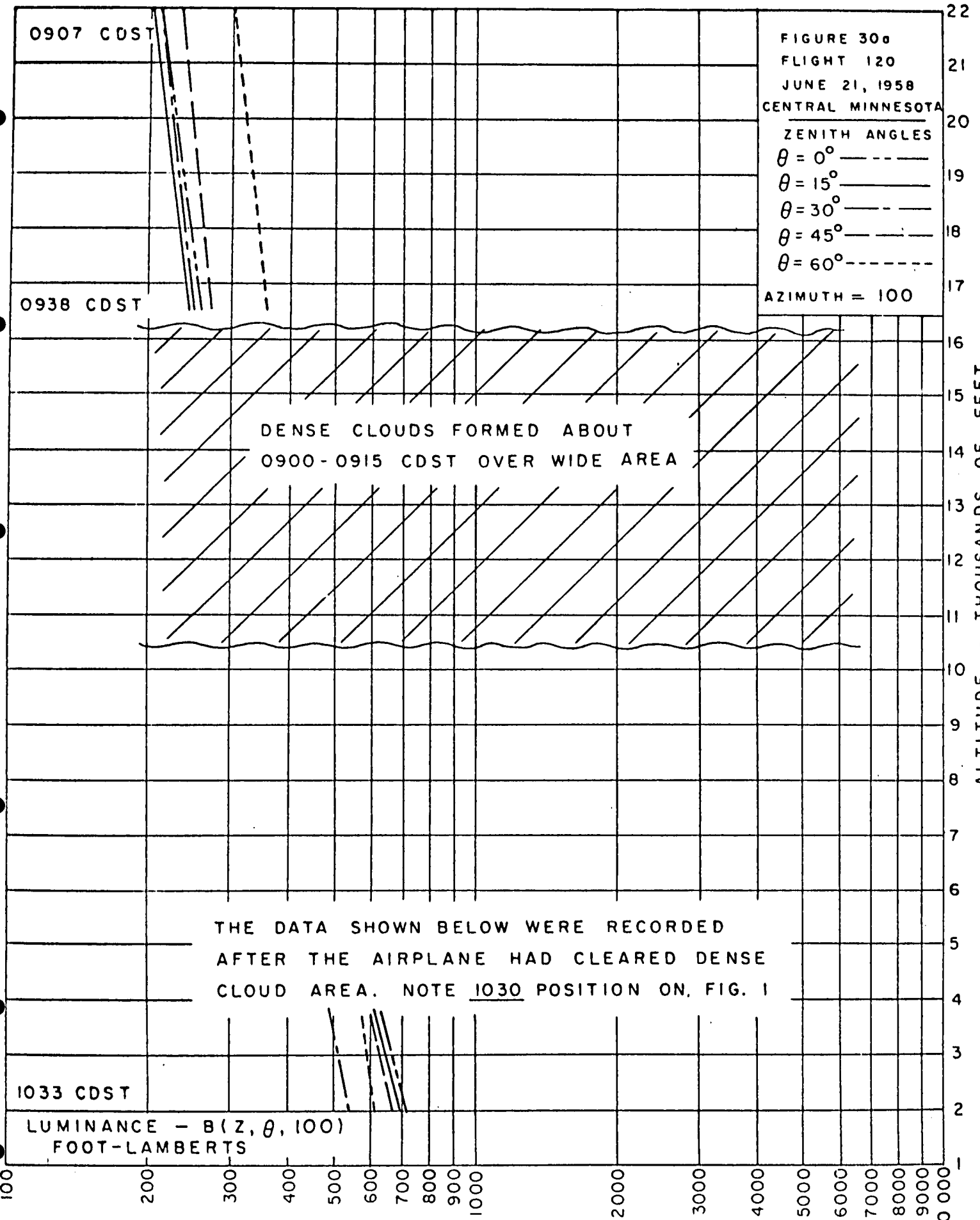


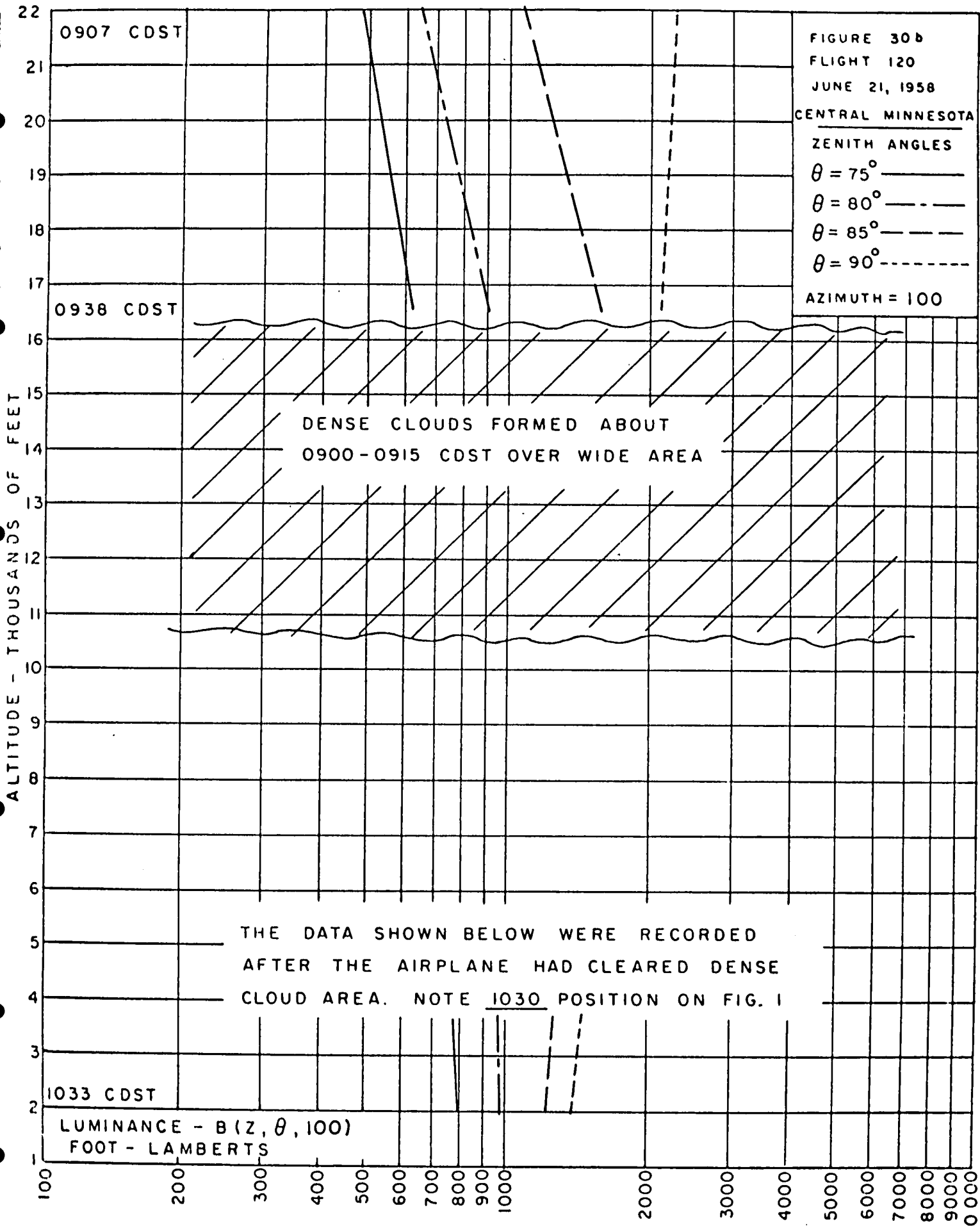


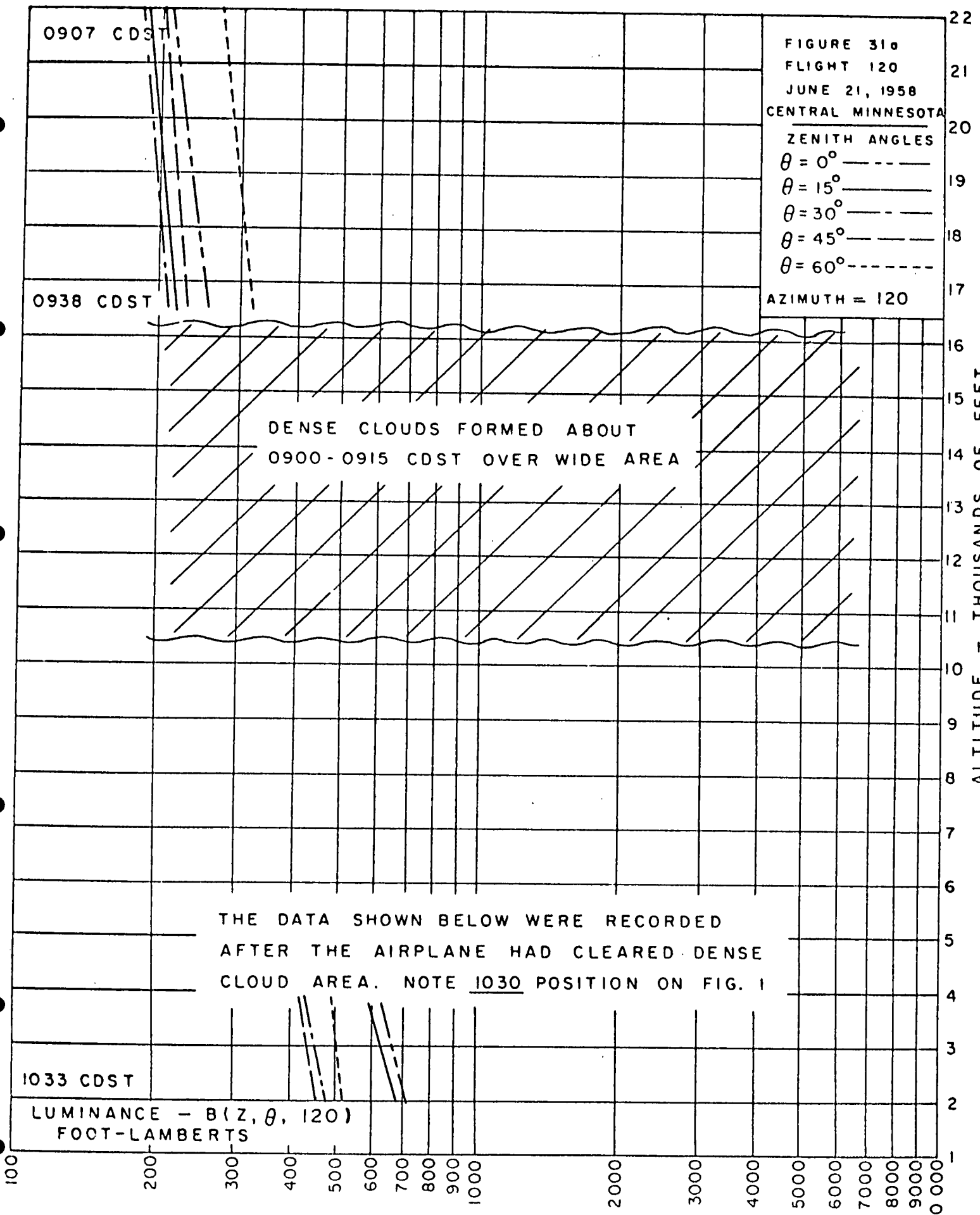


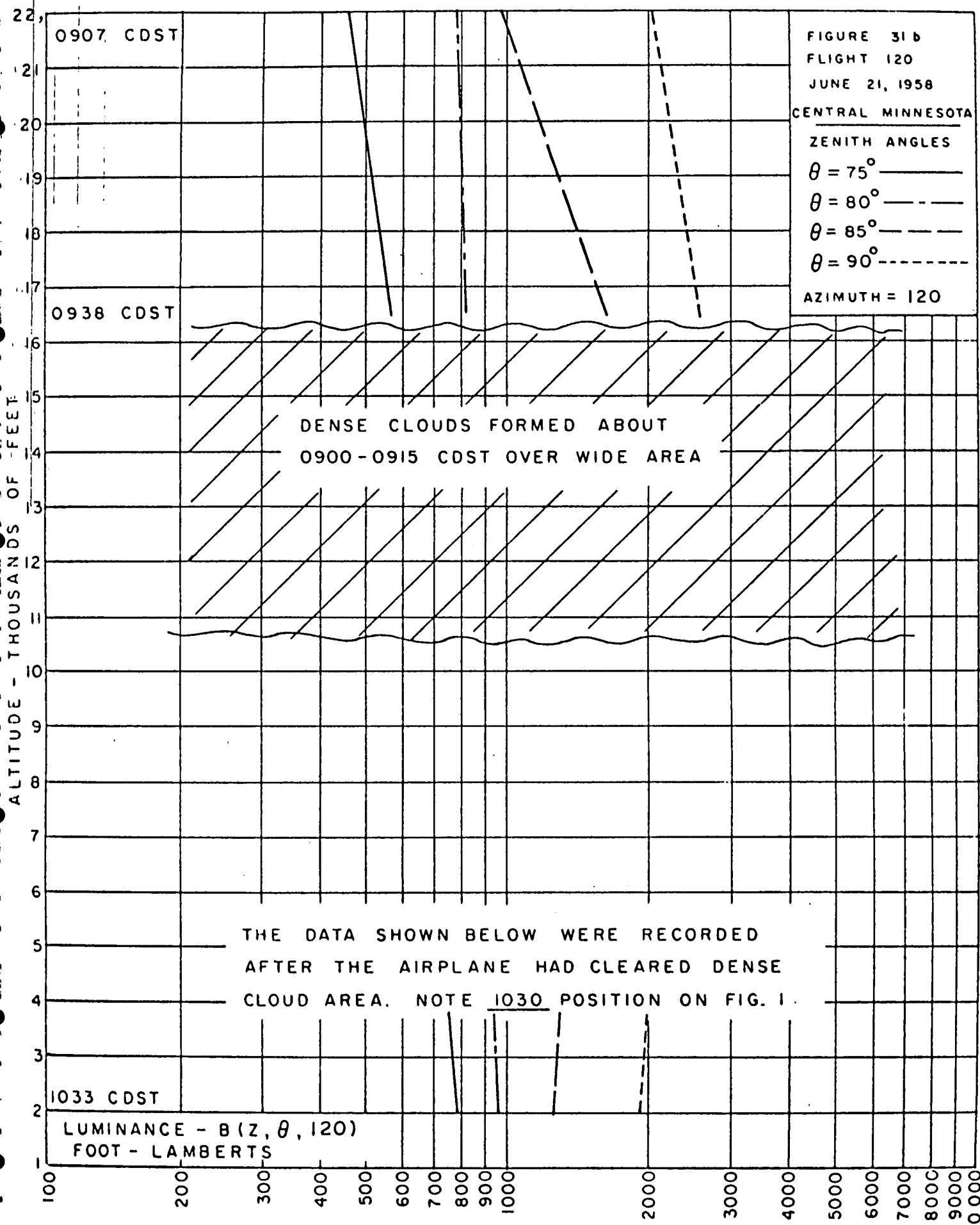


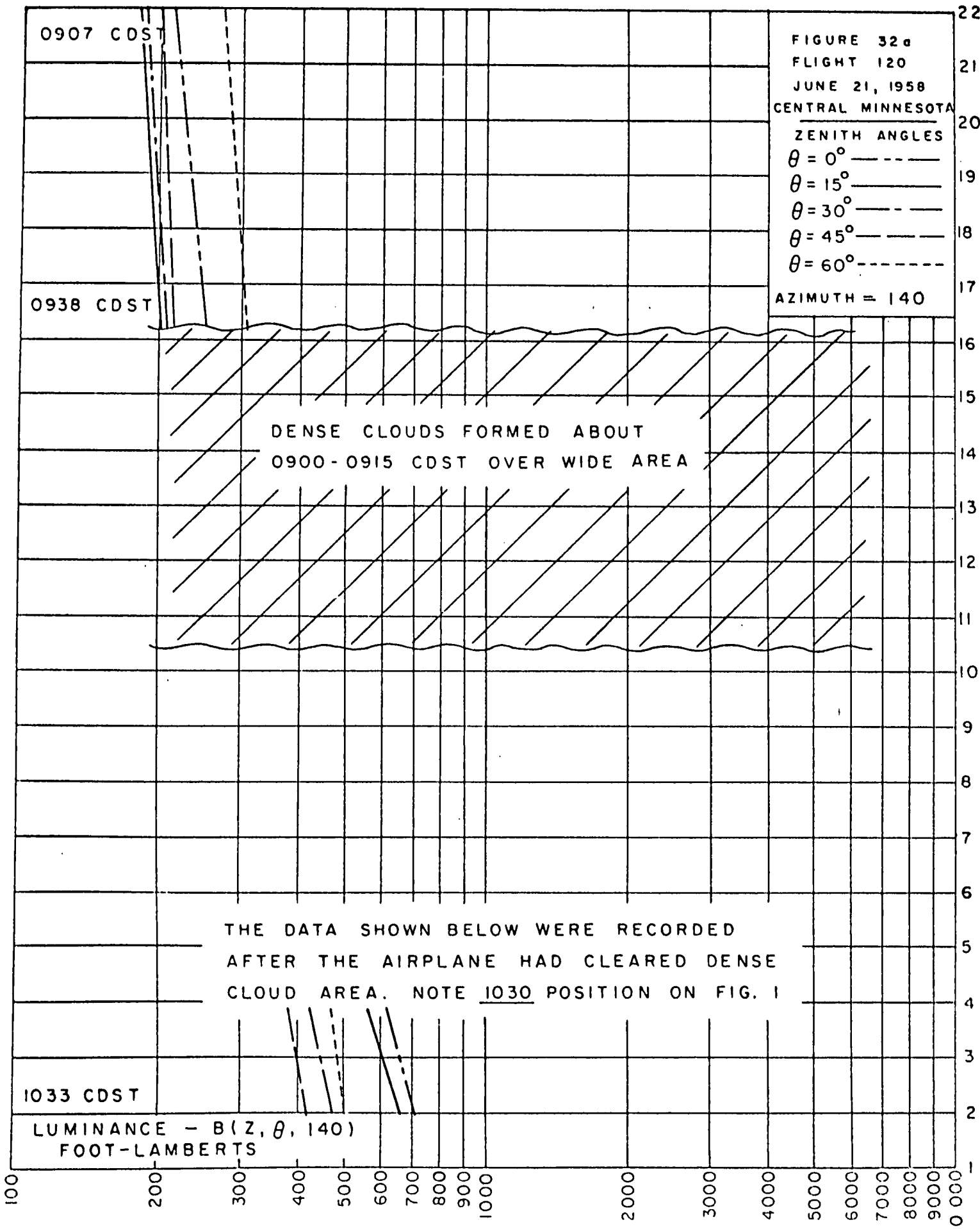


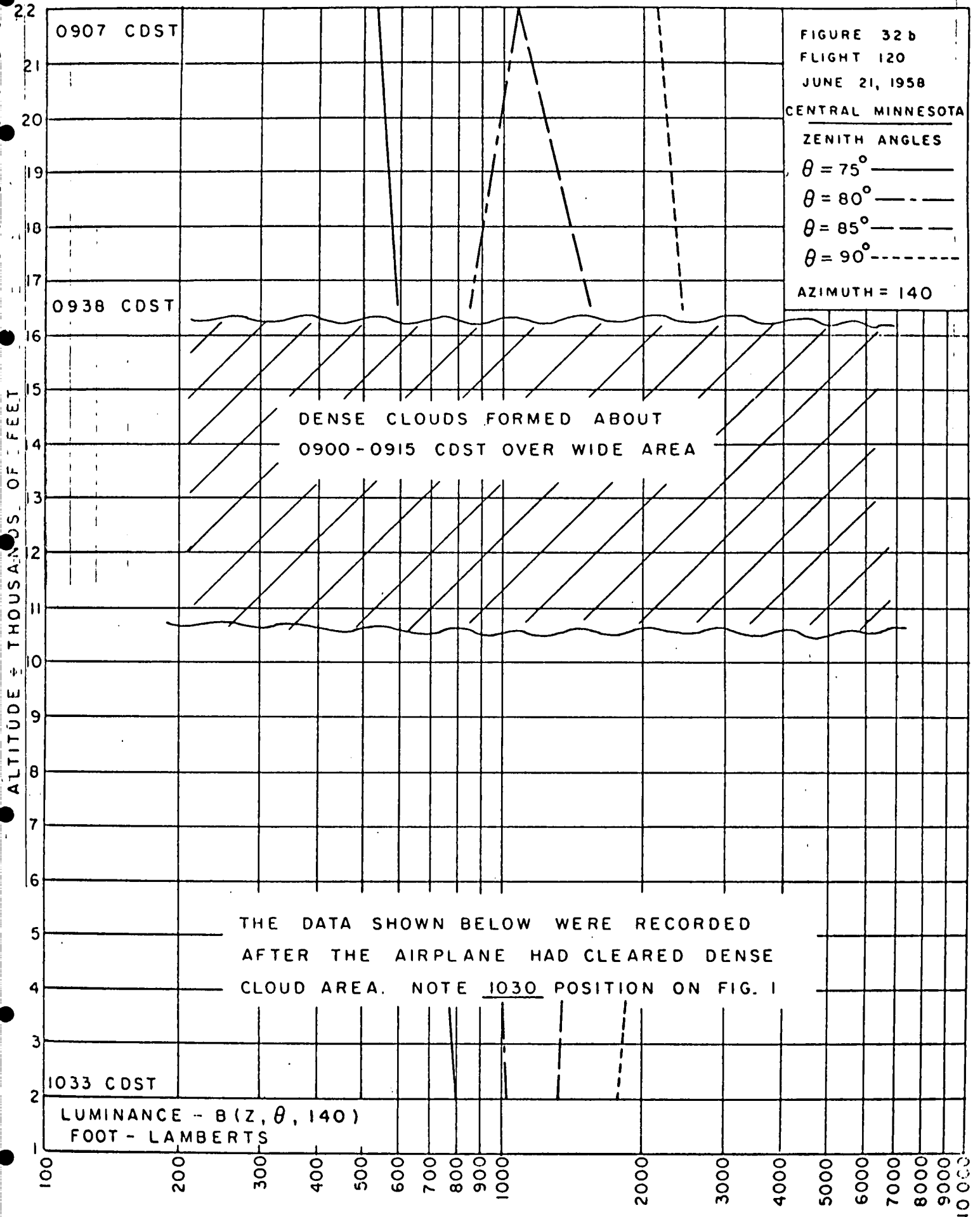


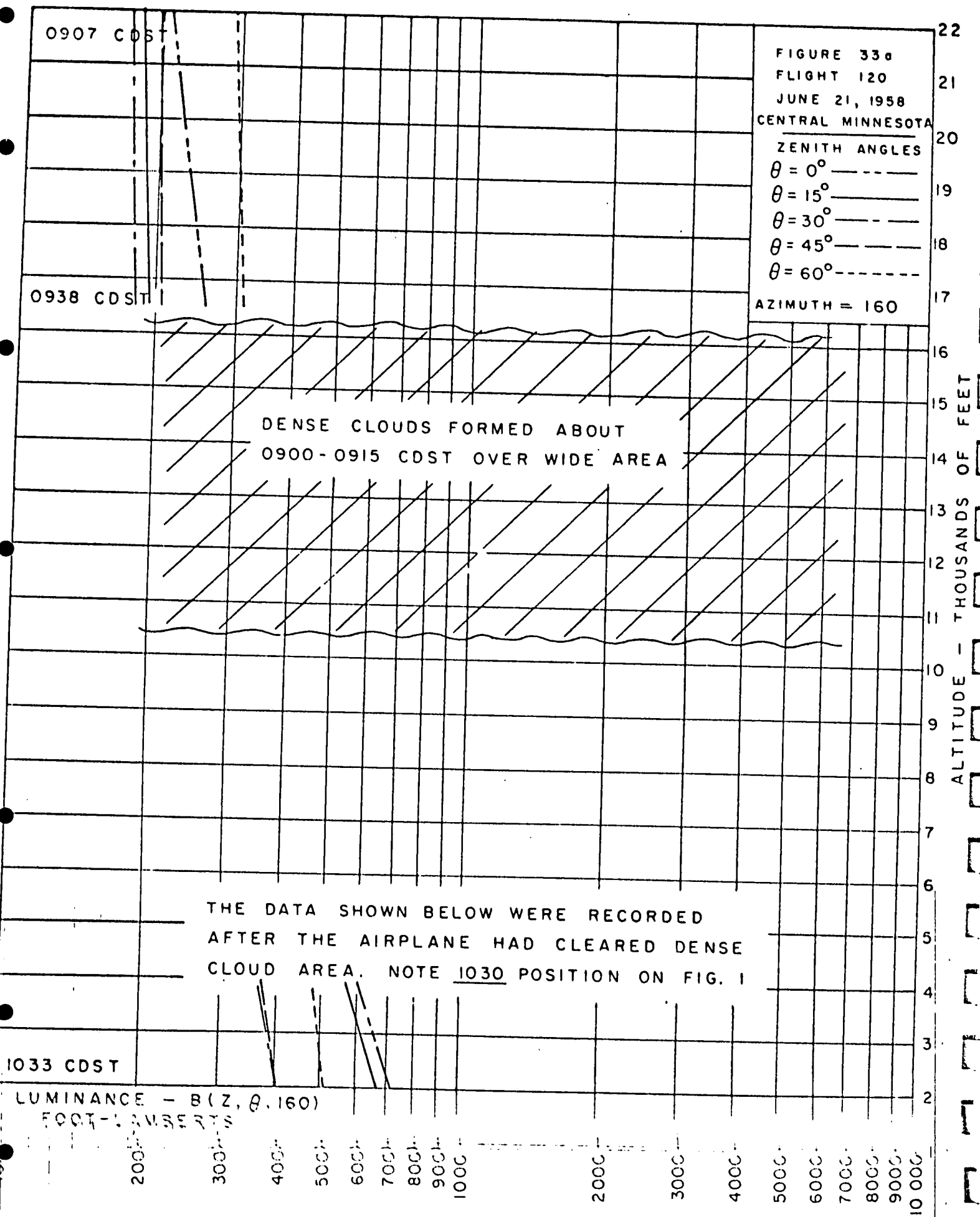


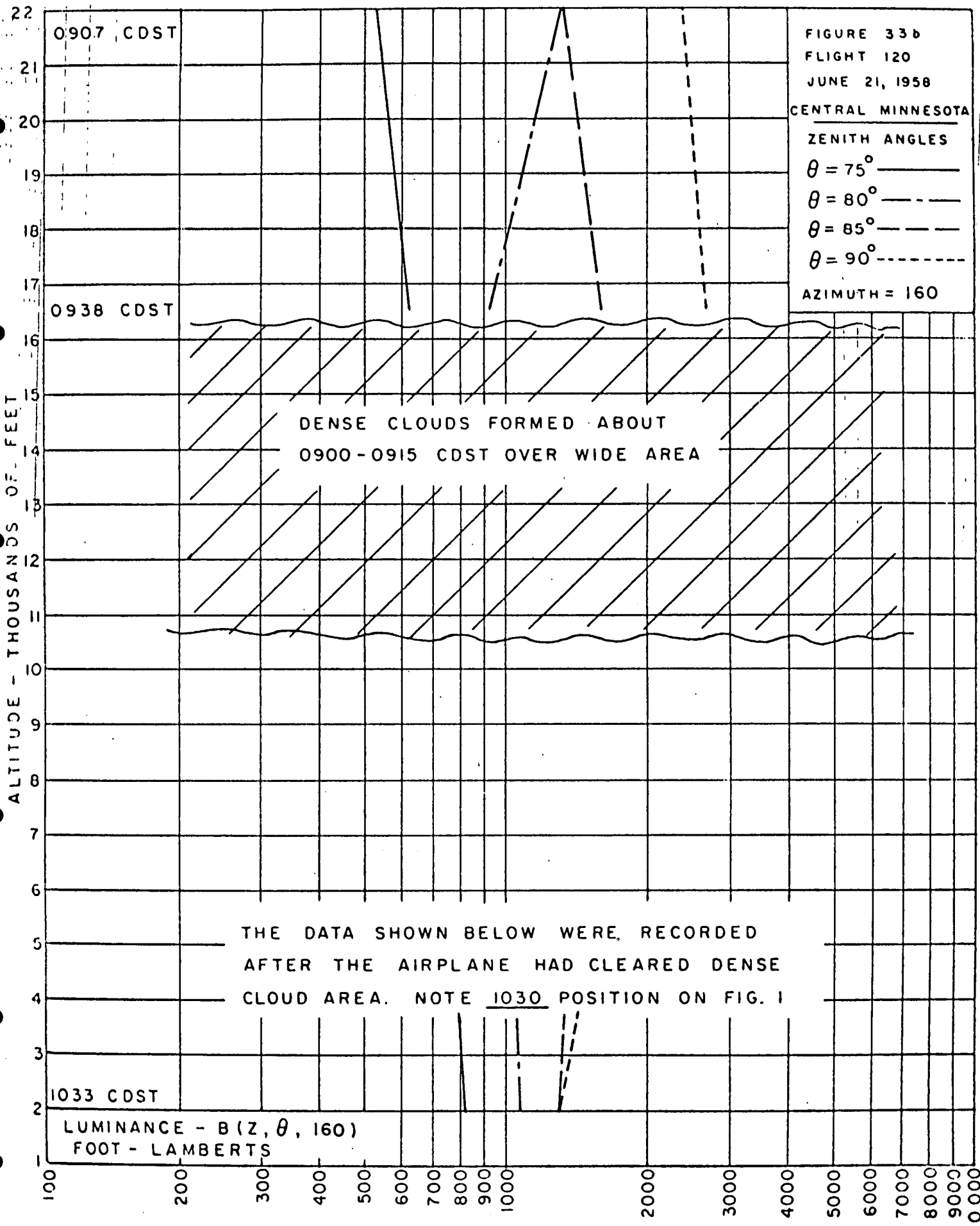


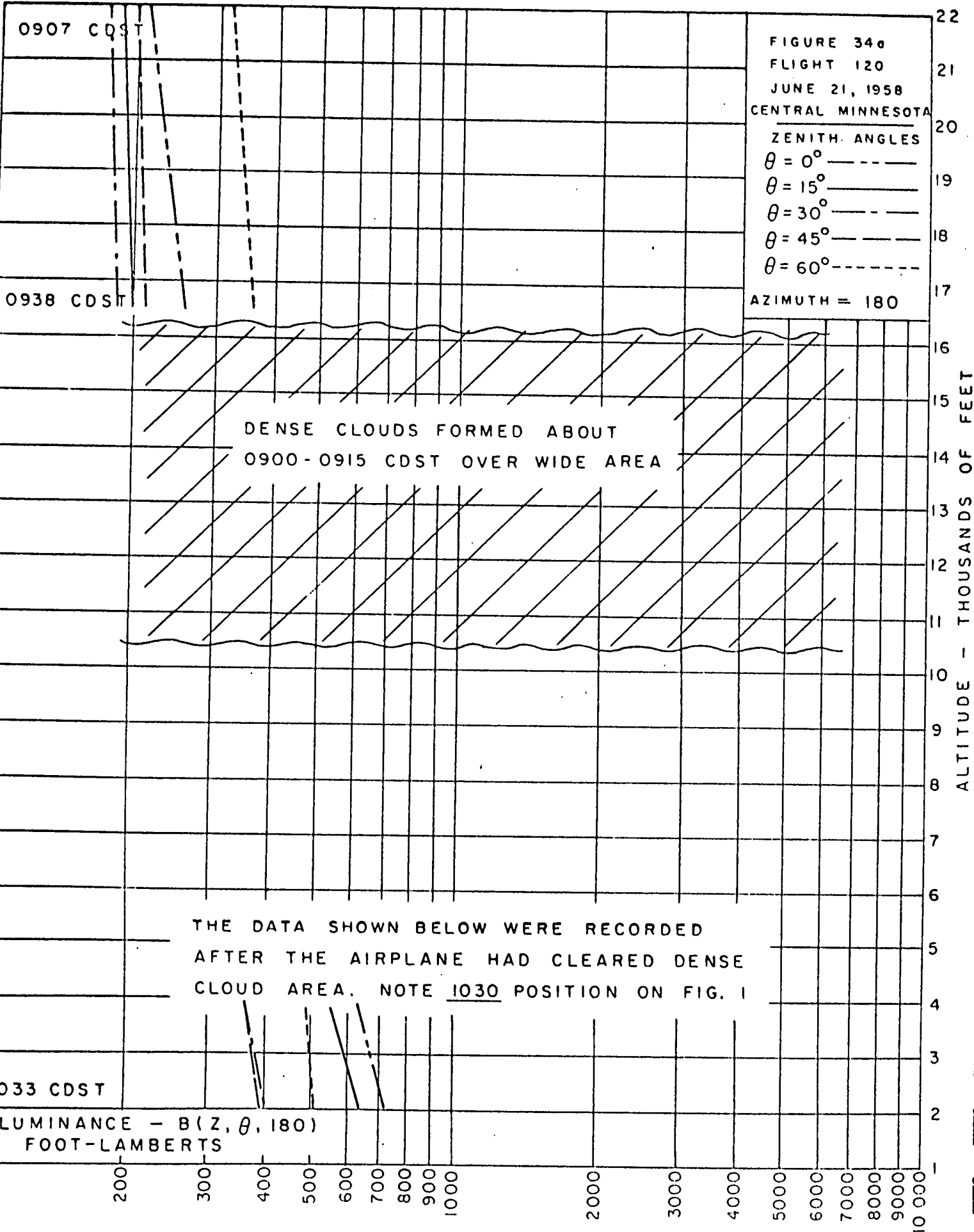


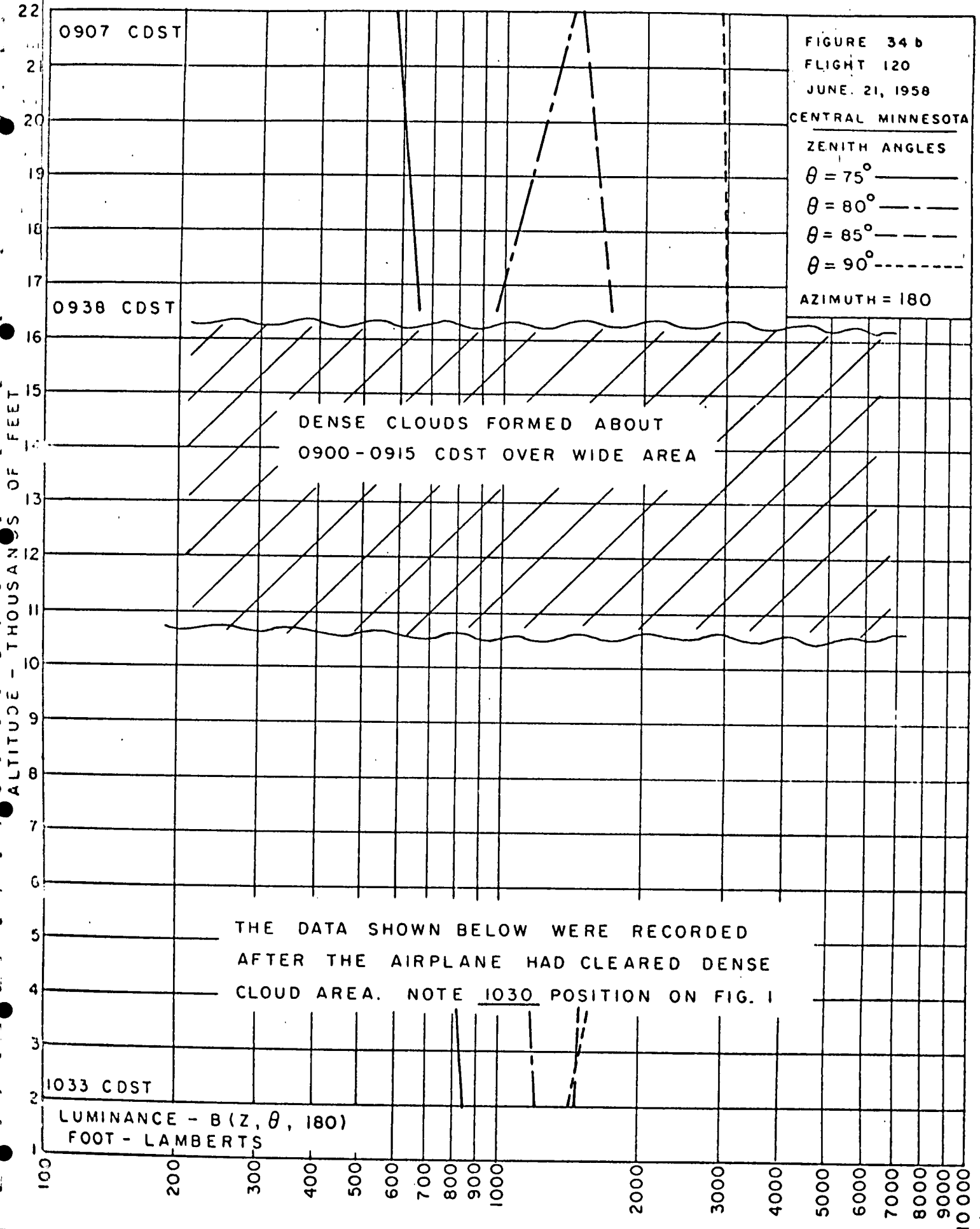


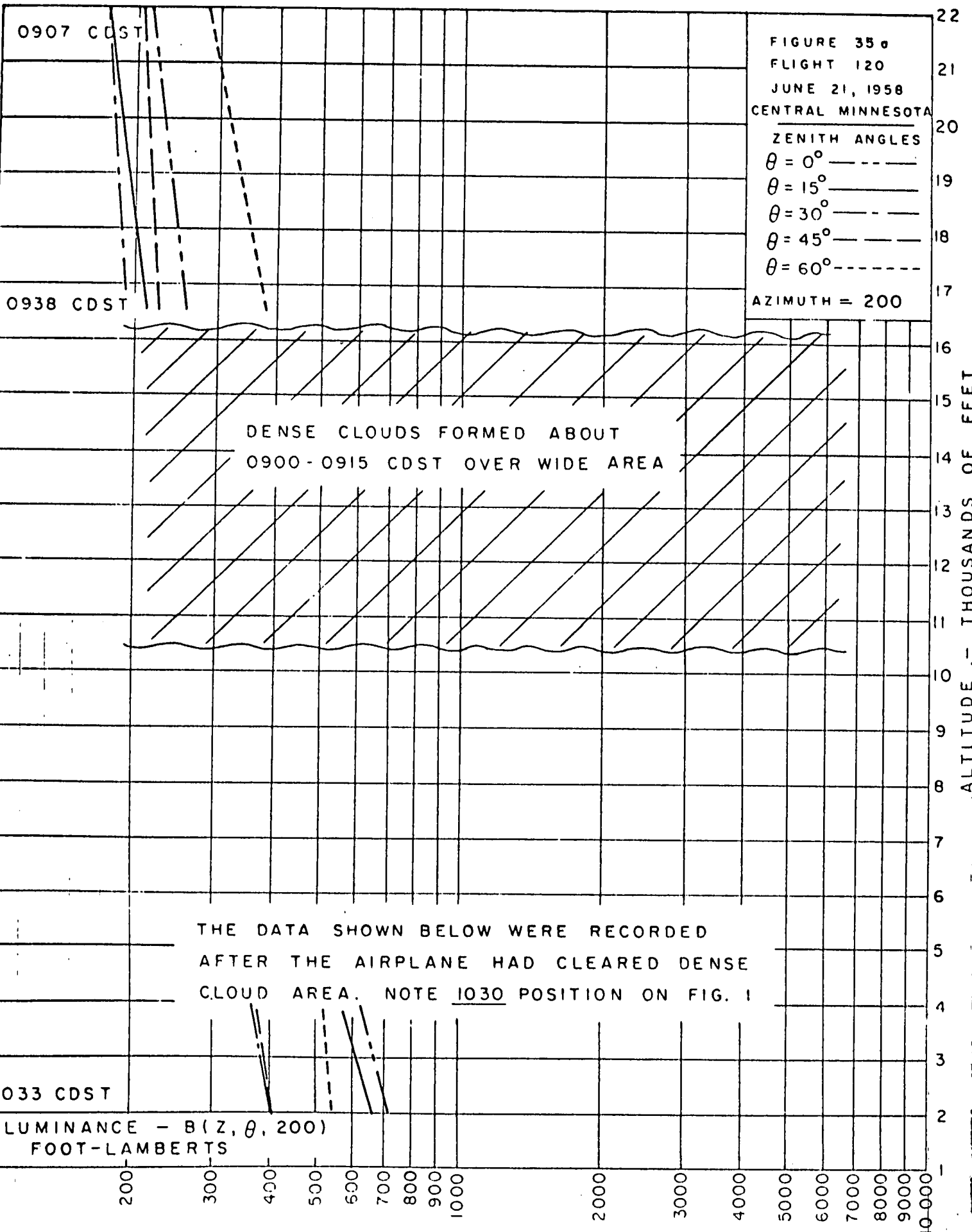


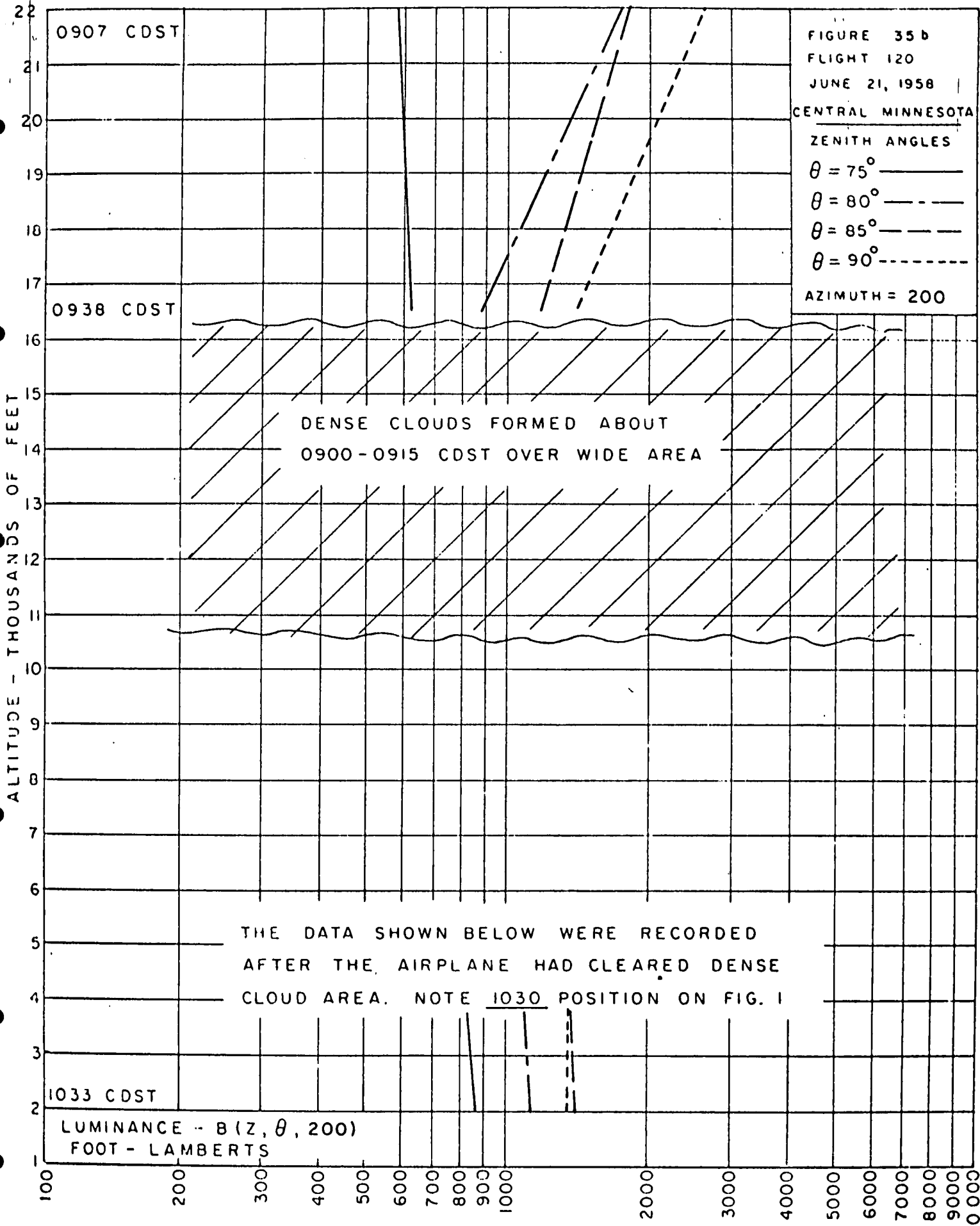


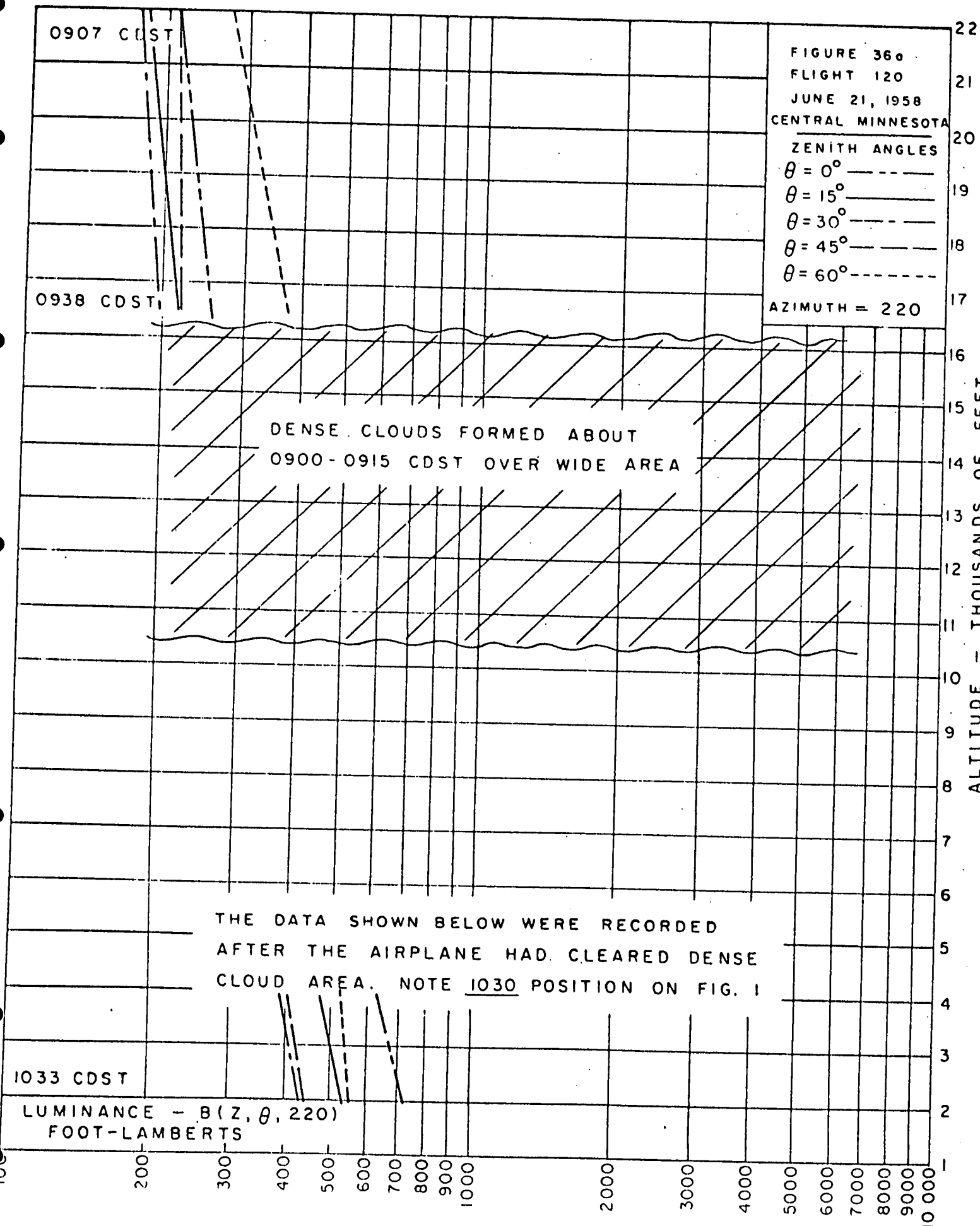












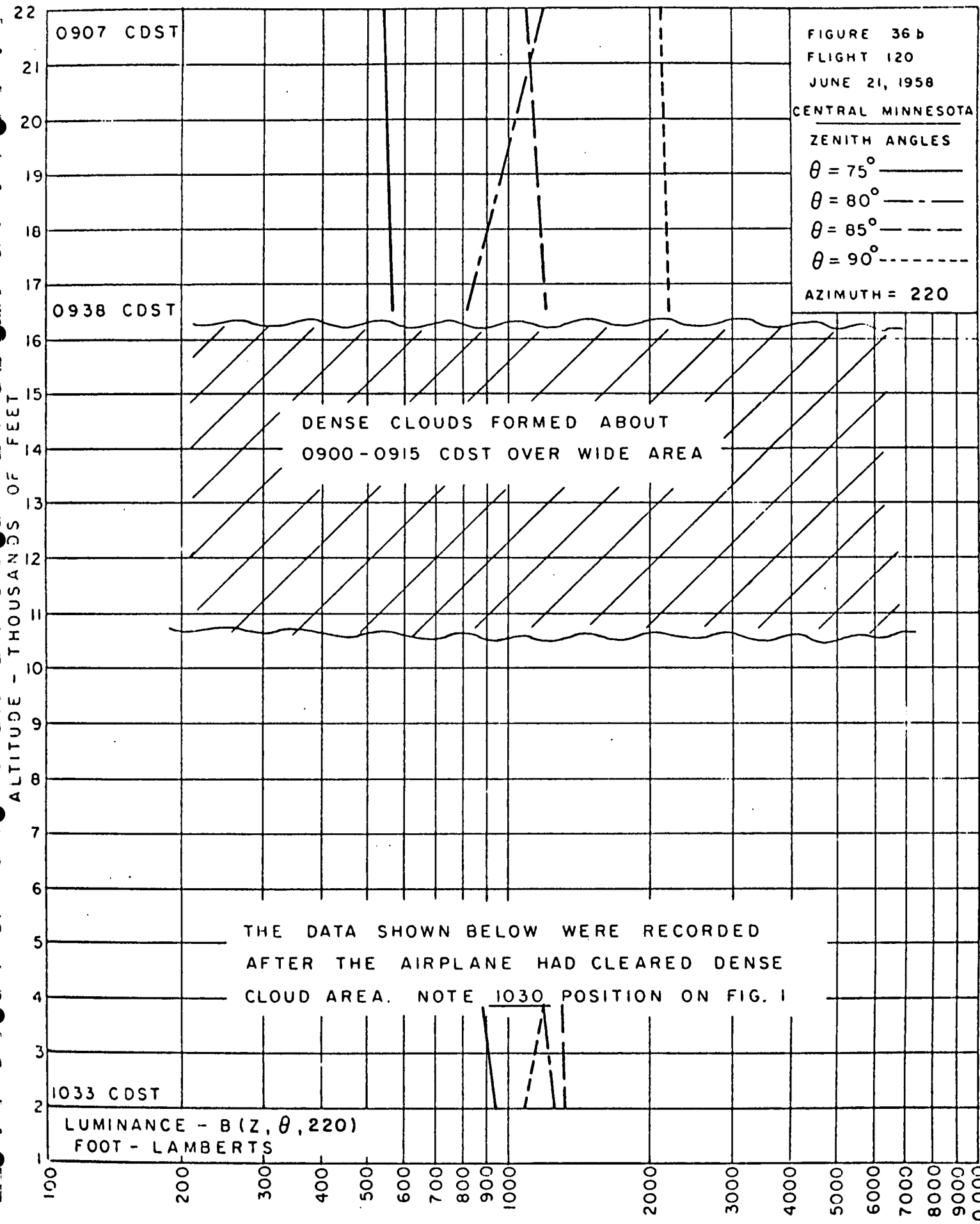
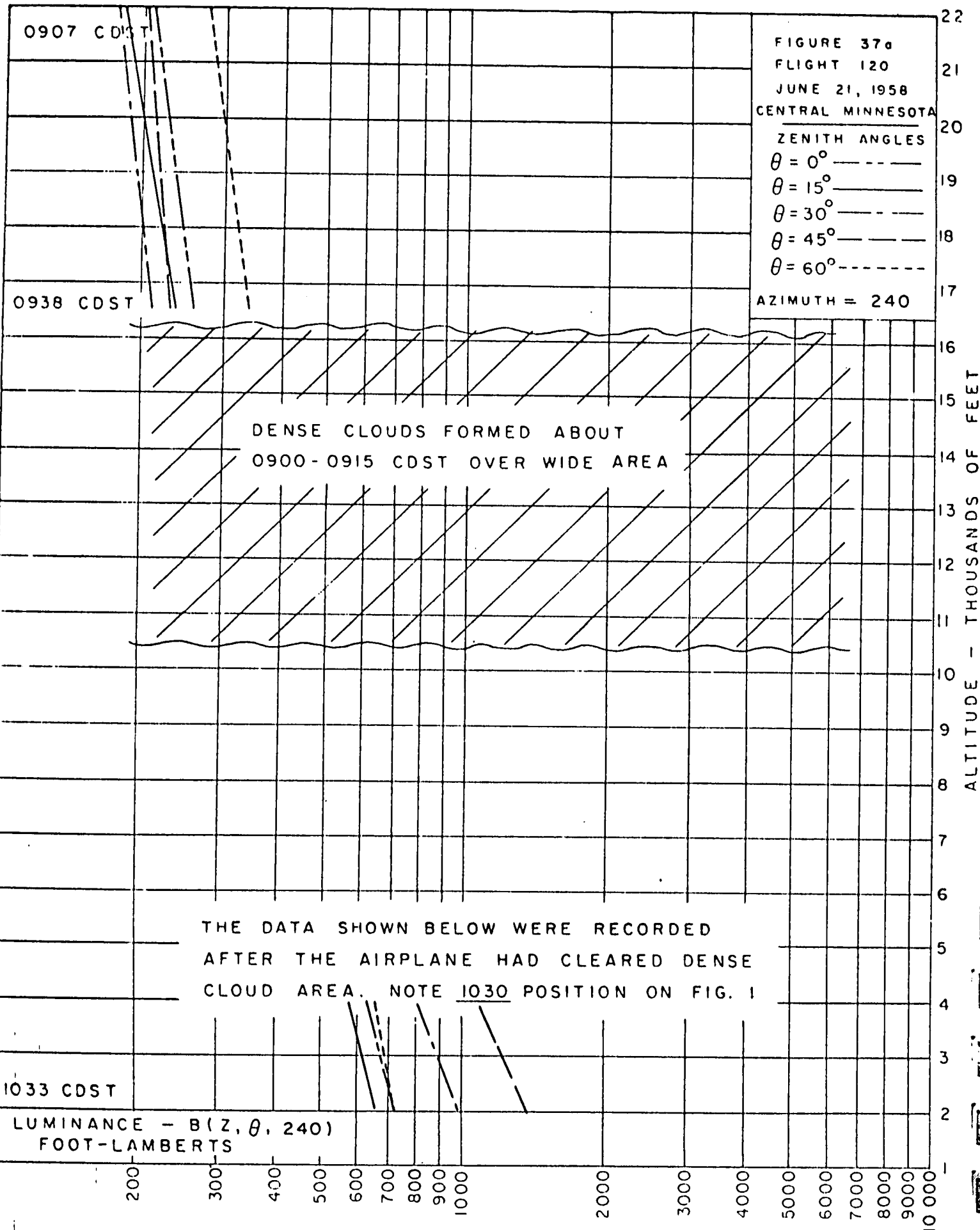


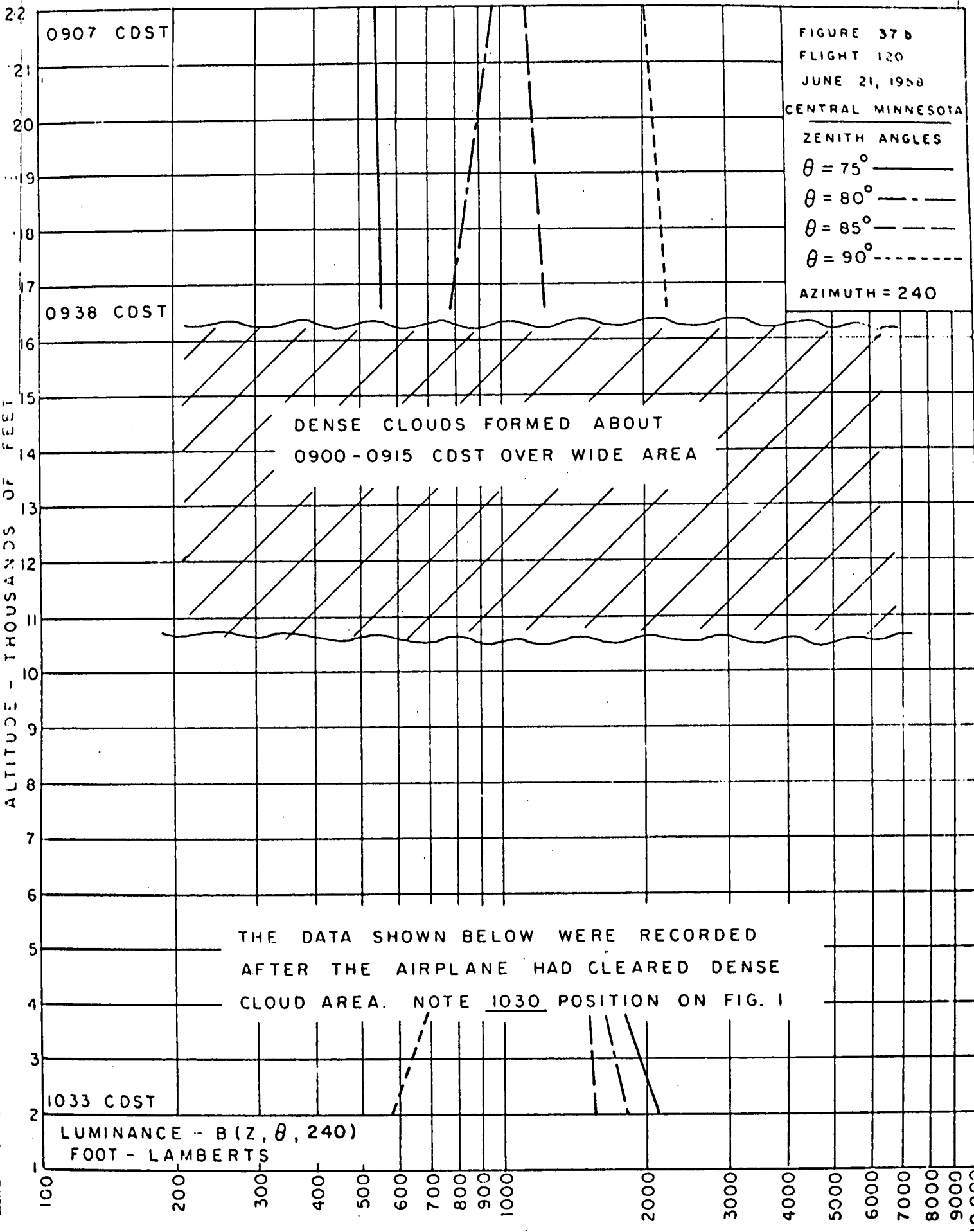
FIGURE 36 b
 FLIGHT 120
 JUNE 21, 1958
 CENTRAL MINNESOTA
 ZENITH ANGLES
 $\theta = 75^\circ$ ———
 $\theta = 80^\circ$ - - - -
 $\theta = 85^\circ$ - · - ·
 $\theta = 90^\circ$ ·····
 AZIMUTH = 220

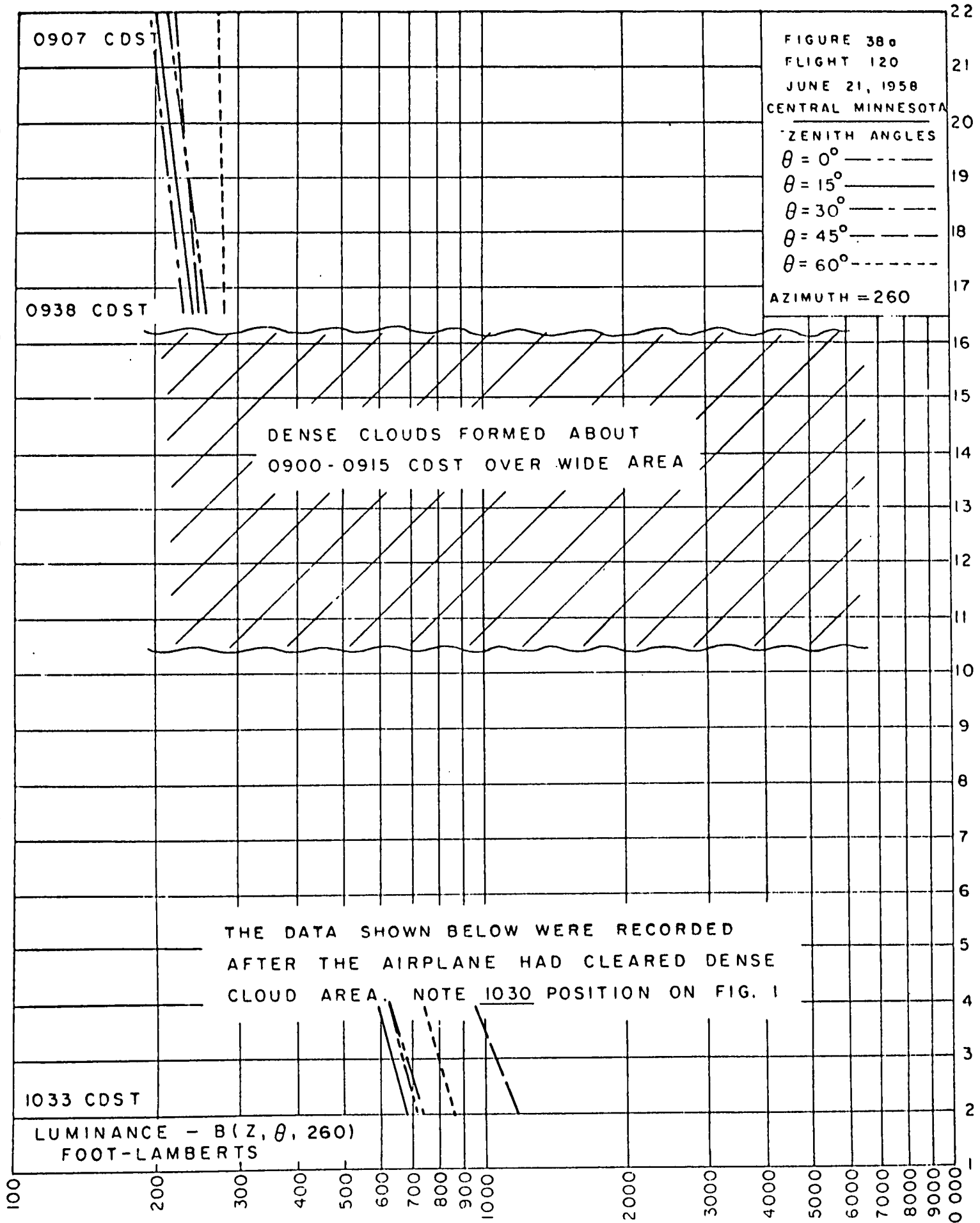
DENSE CLOUDS FORMED ABOUT
 0900 - 0915 CDST OVER WIDE AREA

THE DATA SHOWN BELOW WERE RECORDED
 AFTER THE AIRPLANE HAD CLEARED DENSE
 CLOUD AREA. NOTE 1030 POSITION ON FIG. 1

1033 CDST
 LUMINANCE - $B(Z, \theta, 220)$
 FOOT - LAMBERTS







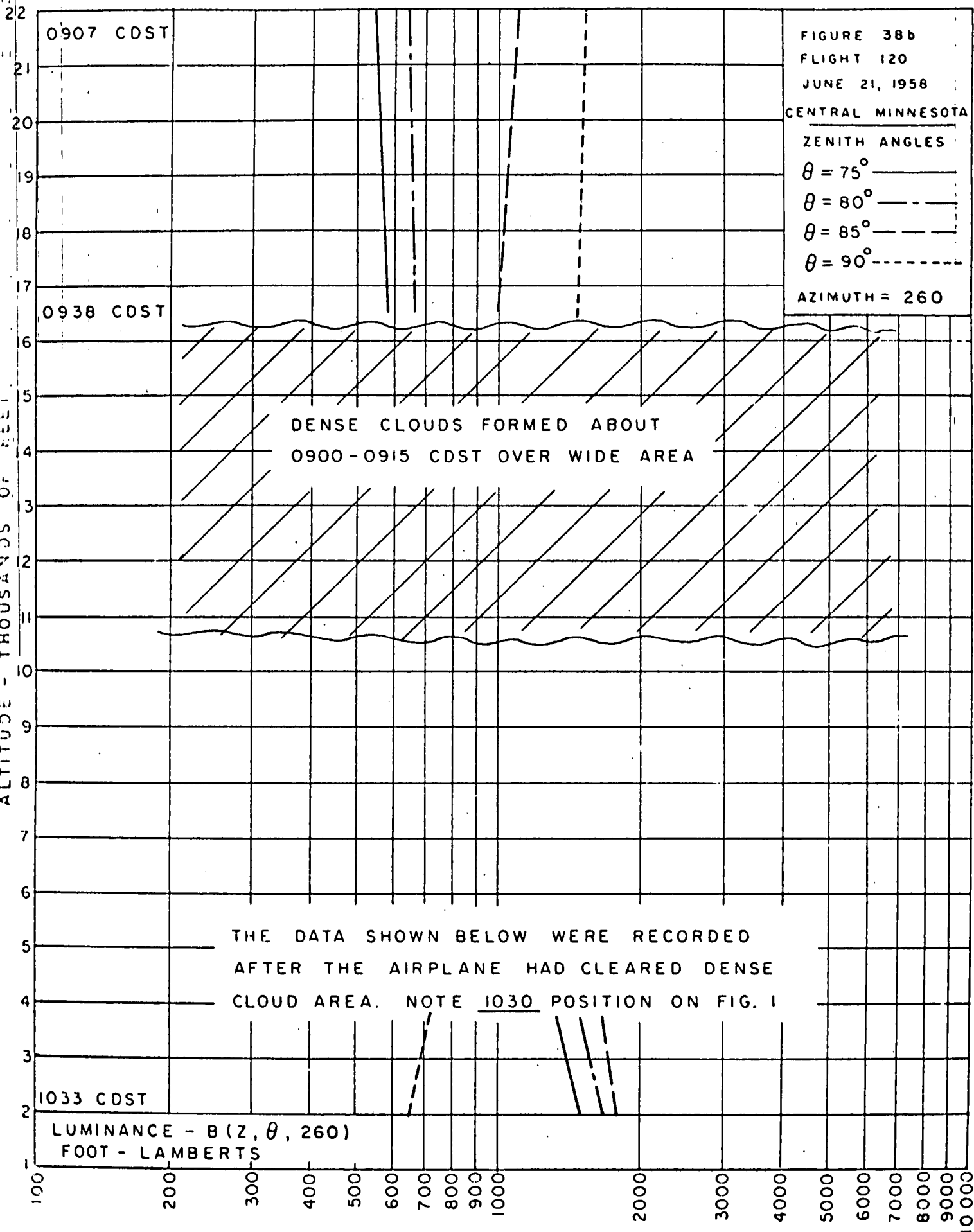


FIGURE 38b
 FLIGHT 120
 JUNE 21, 1958
 CENTRAL MINNESOTA
 ZENITH ANGLES
 $\theta = 75^\circ$ ———
 $\theta = 80^\circ$ - - - -
 $\theta = 85^\circ$ - · - ·
 $\theta = 90^\circ$ ·····
 AZIMUTH = 260

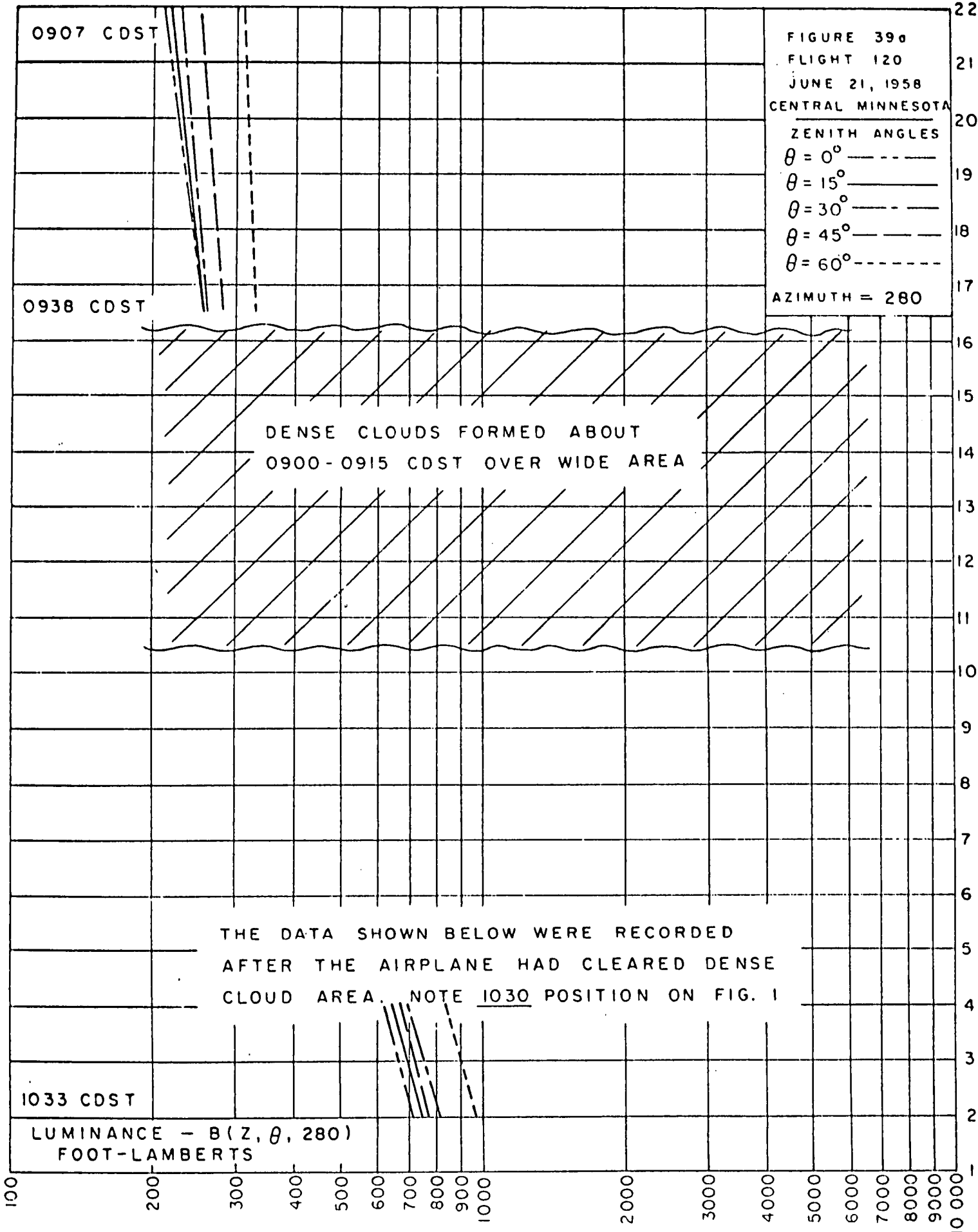
DENSE CLOUDS FORMED ABOUT
 0900-0915 CDST OVER WIDE AREA

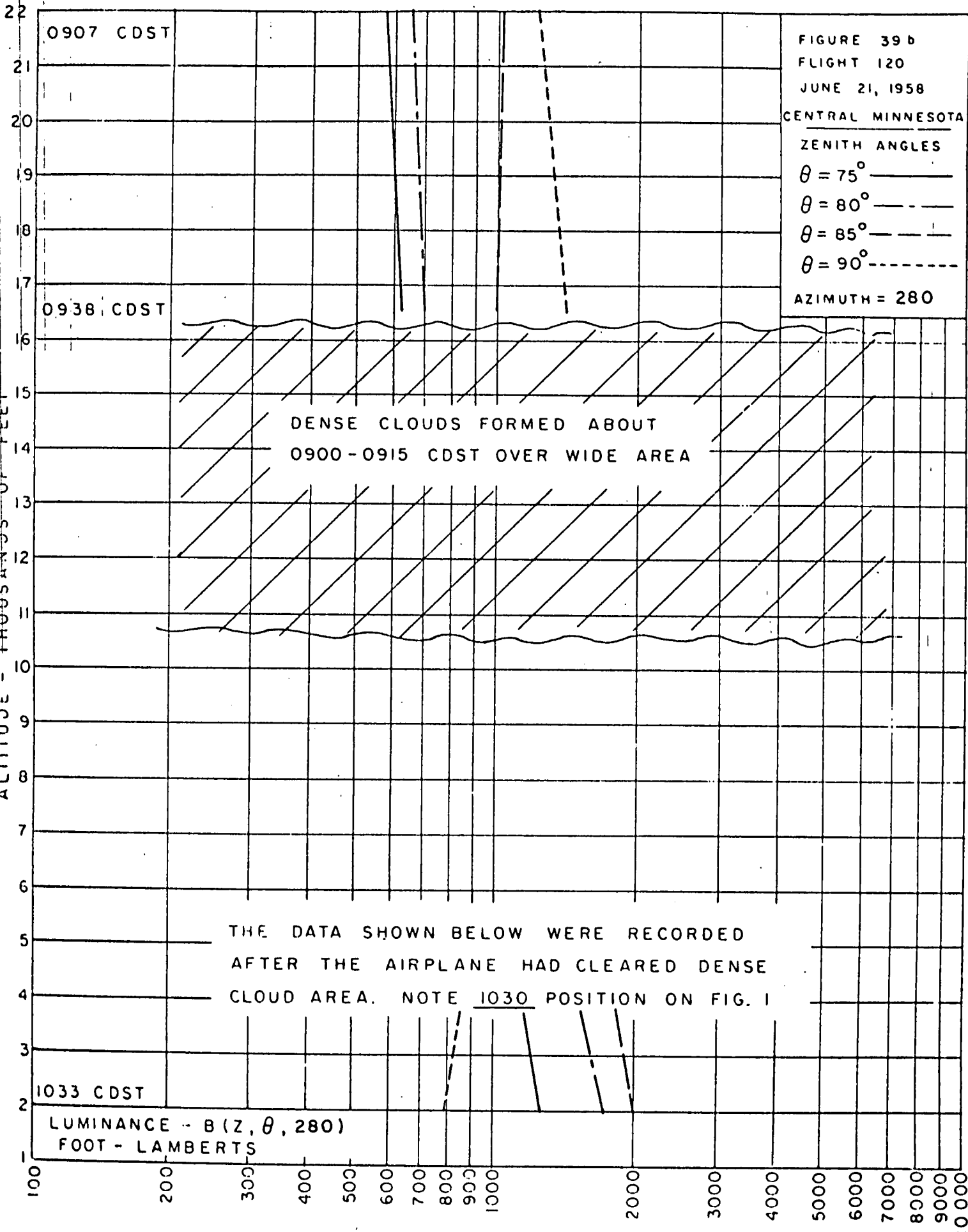
THE DATA SHOWN BELOW WERE RECORDED
 AFTER THE AIRPLANE HAD CLEARED DENSE
 CLOUD AREA. NOTE 1030 POSITION ON FIG. 1

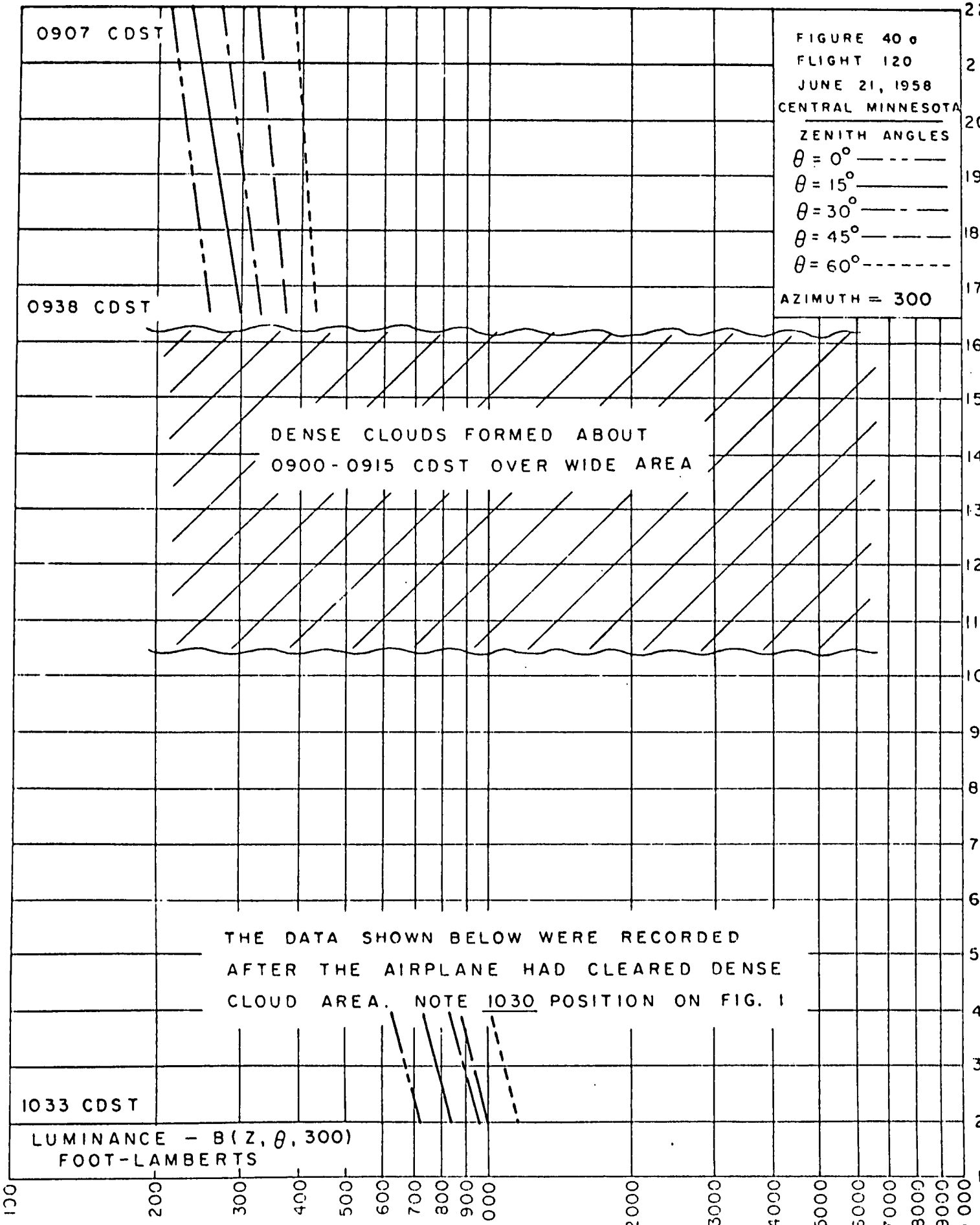
1033 CDST

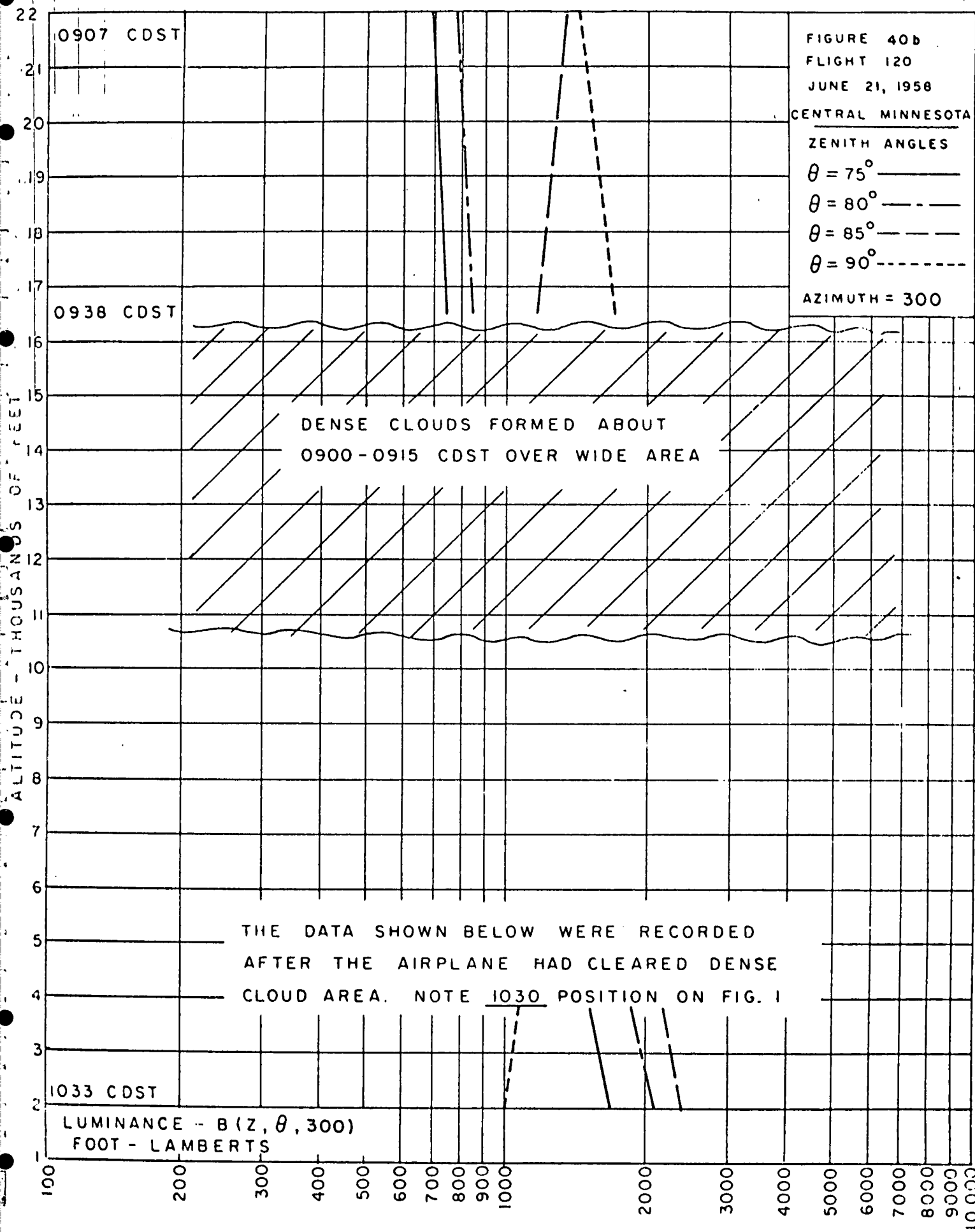
LUMINANCE - $B(Z, \theta, 260)$
 FOOT - LAMBERTS

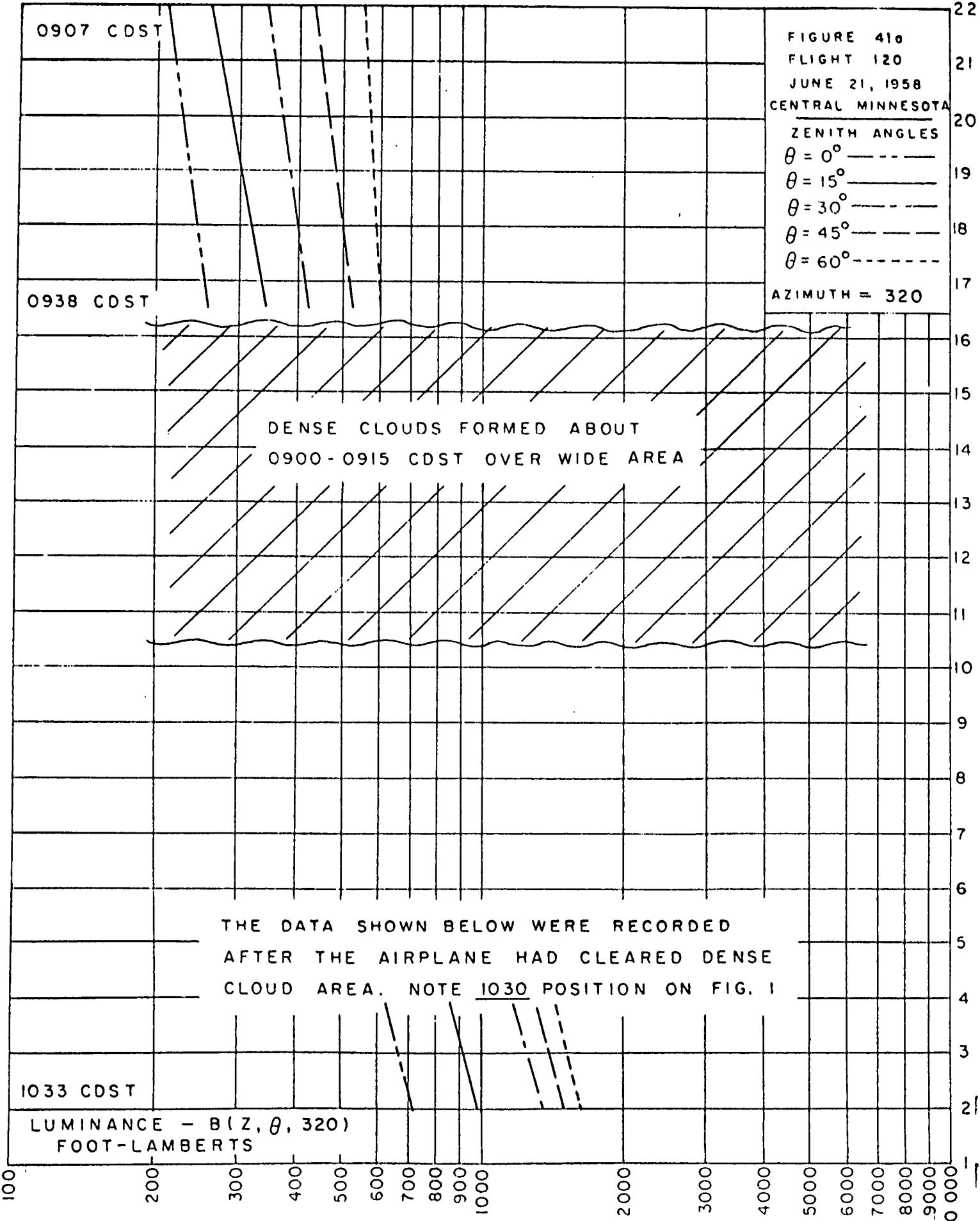
ALTITUDE - THOUSANDS OF FEET

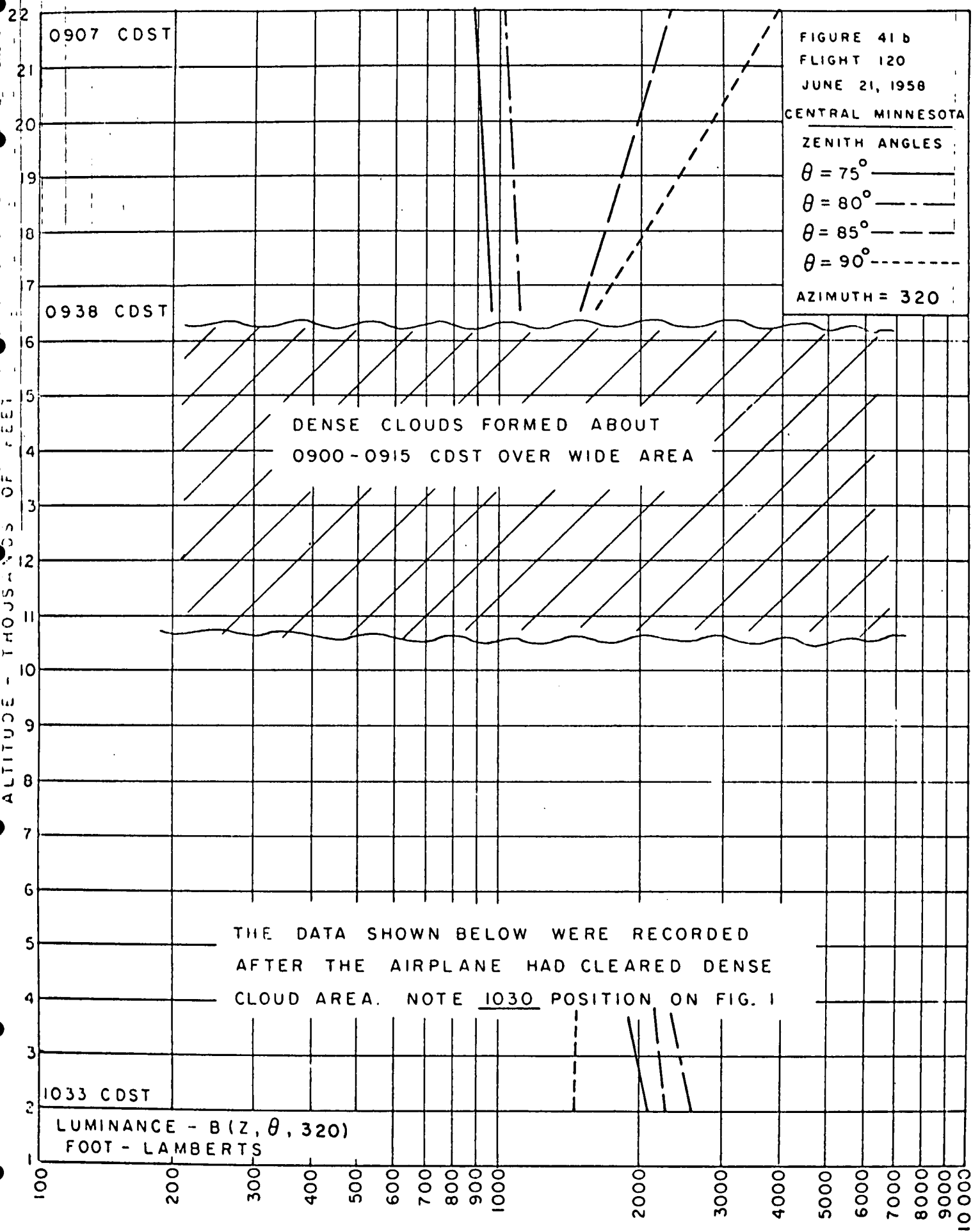












0907 CDST

FIGURE 41 b
 FLIGHT 120
 JUNE 21, 1958
 CENTRAL MINNESOTA

ZENITH ANGLES
 $\theta = 75^\circ$ ———
 $\theta = 80^\circ$ - - -
 $\theta = 85^\circ$ - · -
 $\theta = 90^\circ$ · · ·
 AZIMUTH = 320

0938 CDST

DENSE CLOUDS FORMED ABOUT
 0900 - 0915 CDST OVER WIDE AREA

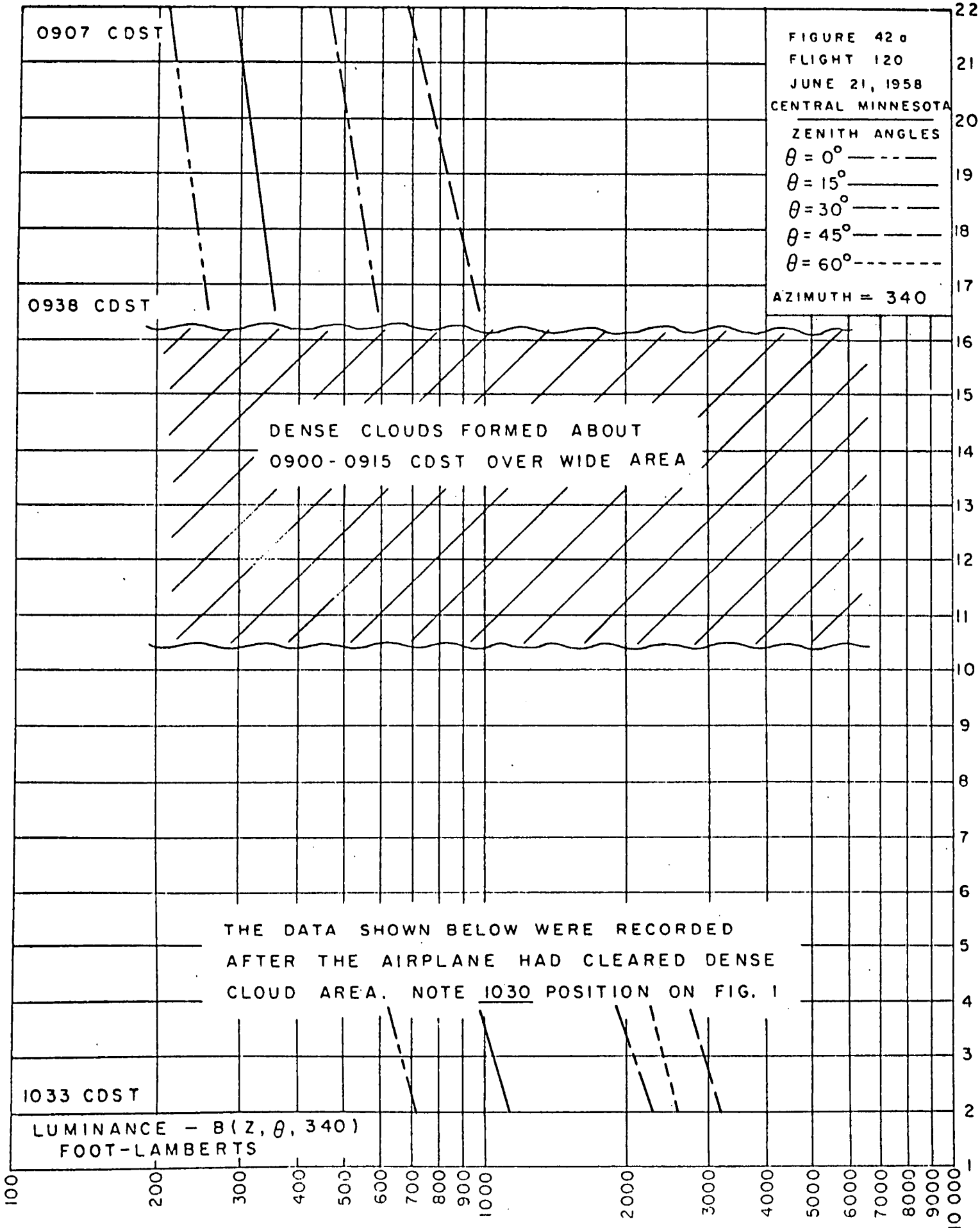
THE DATA SHOWN BELOW WERE RECORDED
 AFTER THE AIRPLANE HAD CLEARED DENSE
 CLOUD AREA. NOTE 1030 POSITION ON FIG. 1

1033 CDST

LUMINANCE - $B(Z, \theta, 320)$
 FOOT - LAMBERTS

ALTITUDE - THOUSANDS OF FEET

100 200 300 400 500 600 700 800 900 1000 2000 3000 4000 5000 6000 7000 8000 9000 10000



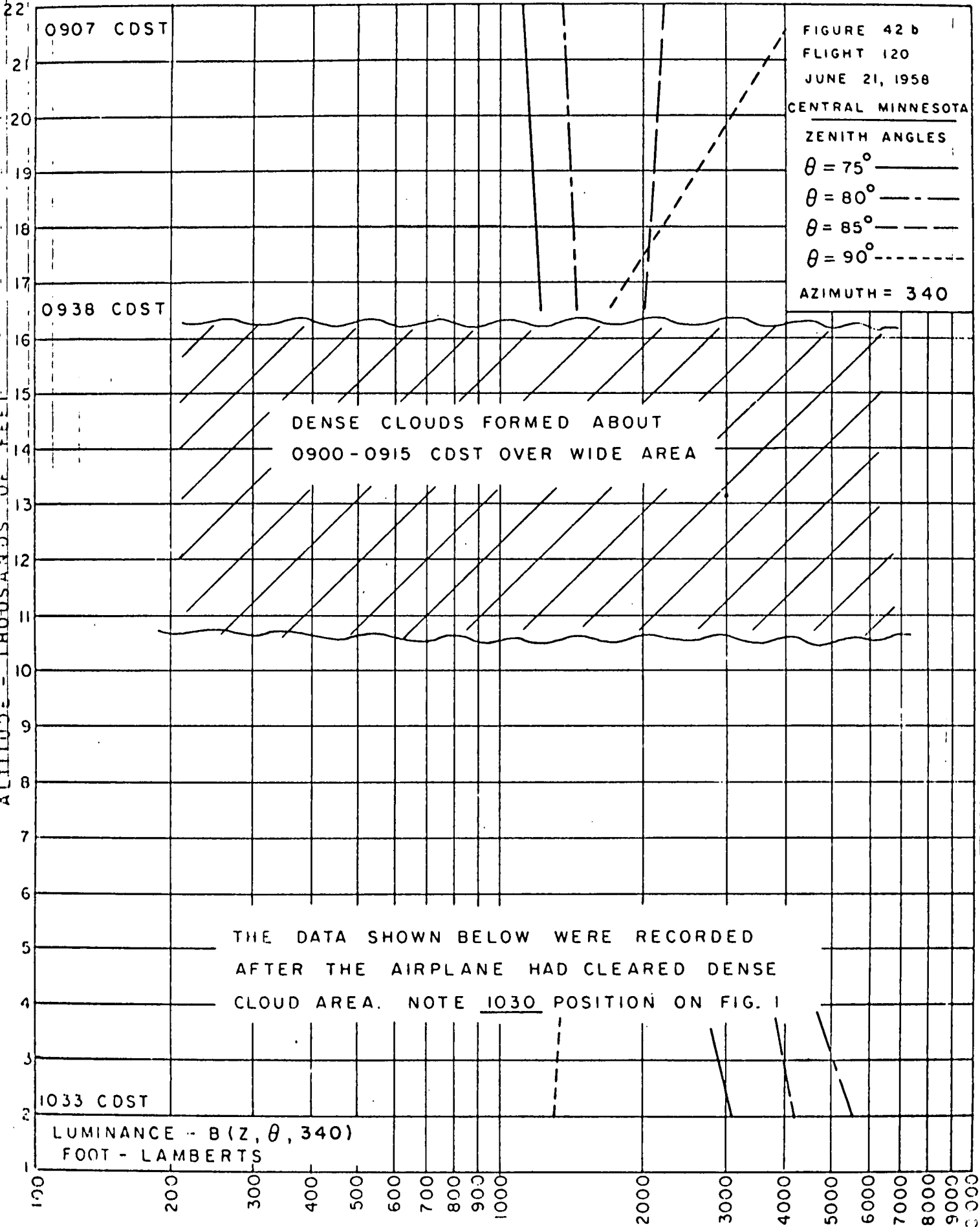


FIGURE 42 b
 FLIGHT 120
 JUNE 21, 1958
 CENTRAL MINNESOTA
 ZENITH ANGLES
 $\theta = 75^\circ$ ———
 $\theta = 80^\circ$ - - - -
 $\theta = 85^\circ$ - · - ·
 $\theta = 90^\circ$ ·····
 AZIMUTH = 340

DENSE CLOUDS FORMED ABOUT
 0900-0915 CDST OVER WIDE AREA

THE DATA SHOWN BELOW WERE RECORDED
 AFTER THE AIRPLANE HAD CLEARED DENSE
 CLOUD AREA. NOTE 1030 POSITION ON FIG. 1

0907 CDST

0938 CDST

1033 CDST

LUMINANCE - $B(Z, \theta, 340)$
 FOOT - LAMBERTS

ALTITUDE - THOUSANDS OF FEET

100 200 300 400 500 600 700 800 900 1000 2000 3000 4000 5000 6000 7000 8000 9000 10000

6. REFERENCES

1. Boileau, A.R., "Atmospheric Optical Measurements during High Altitude Balloon Flight, Part I," SIO Ref. 59-32-(1), Scripps Institution of Oceanography, University of California, La Jolla Campus, December 1959.
2. Duntley, S.Q., A.R. Boileau and R.W. Preisendorfer, "Image Transmission by the Troposphere I," J. Opt. Soc. Am. 47, 499-506 (1957).

7. ACKNOWLEDGEMENTS

While the assistance of all who have helped in this work is fully appreciated, special mention is made of the crew of the XB-29 No.4224725, Capt. Ben V. Walker, USAF, Aircraft Commander, Capt. Louis Prestwood, USAF, Co-Pilot, and Air Force Command and Control Development Division Test Support Group.

DISTRIBUTION LIST

Office of the Director of Defense
Defense Research and Engineering
Information Office Library Branch
Pentagon Building
Washington 25, D.C. (2)

Armed Services Technical Information
Agency
Arlington Hall Station
ATTN: TIPCR
Arlington 12, Virginia (5)

Chief, Bureau of Weapons
Technical Library
Navy Department
Washington 25, D.C.

Chief, Bureau of Ships
Code 300, Technical Library
Navy Department
Washington 25, D.C.

Chief of Naval Research
Office of Naval Research
ATTN: Physics Branch
Washington 25, D.C. (3)

Director
U.S. Naval Research Laboratory
Technical Information Officer
Code 2000, Code 2021
Washington 25, D.C. (6)

Commanding Officer
Office of Naval Research
Branch Office
499 Summer Street
Boston 10, Massachusetts

Commanding Officer
Office of Naval Research
Branch Office
346 Broadway
New York 13, New York

Contract Administrator
Southeastern Area
Office of Naval Research
George Washington University
2110 "G" Street N.W.
Washington 7, D.C.

Commanding Officer
Office of Naval Research
Branch Office
86 East Randolph Street
Chicago 1, Illinois

Commanding Officer
Office of Naval Research
Branch Office
(Dr. Ed. Edelsack)
1000 Geary Street
San Francisco 9, California (1)

Commanding Officer
Office of Naval Research
Branch Office
1030 East Green Street
Pasadena 1, California

Commanding Officer
Office of Naval Research
Branch Office
Navy No. 100 Box 39 Fleet P.O.
New York, New York (2)

U.S. Navy Radiological
Defense Center
San Francisco, California

Librarian
U.S. Naval Post Graduate School
Monterey, California

Commanding Officer
U.S. Naval War College
Newport, Rhode Island

Director
Research Department
U.S. Naval Ordnance Laboratory
White Oak, Silver Spring, Maryland

Commanding Officer
Physics Division
U.S. Naval Ordnance
Test Station
Inyokern, China Lake, California

Commanding Officer
U.S. Naval Ordnance Laboratory
Corona, California

Commanding Officer
Wright Air Development Division
Air Research and Development
Command - U.S. Air Force
Wright - Patterson Air Force Base
Dayton, Ohio

Commanding Officer
AFSWC, SWRP
Kirkland Air Force Base
New Mexico

Headquarters
Air Force Cambridge Research
Air Force Research Division (ARDC)
Geophysics Research Director
Bedford, Massachusetts

Commanding Officer
U.S. Army Engineering
Research and Development Laboratory
Fort Belvoir, Virginia
ATTN: Technical Intell. Branch

U.S. Army Research Office
Box CM, Duke Station
Durham, North Carolina (2)

U.S. Army Signal Engineering
Laboratory
Fort Monmouth, New Jersey
ATTN: Technical Information
Officer (2)

Dr. J.L. Martin
Watertown Arsenal
Watertown 72, Massachusetts

Director
National Bureau of Standards
Washington 25, D.C.

Director
National Bureau of Standards
Boulder, Colorado

Advanced Research Projects Agency
The Pentagon
Room 3E157
Washington 25, D.C.

National Aeronautics and Space
Administration
1520 "H" Street, N.W.
Washington 25, D.C.

National Research Council
Division of Physical Sciences
National Academy of Sciences
Washington 25, D.C.

Director
National Science Foundation
Washington 25, D.C.

U.S. Atomic Energy Commission
Technical Information Service
P.O. Box 62
Oak Ridge, Tennessee

Defense Atomic Support Agency
Sandia Base, New Mexico

Defense Atomic Support Agency
Washington 25, D.C.

Office of Secretary of Defense
(DDR+E, Technical Library)
Washington 25, D.C.
U (1)

Hq USAF (AFCSA, Secretary)
Washington 25, D.C. (1)

Hq USAF (AFDRT) Washington 25, D.C.	(1)	Library National Bureau of Standards Washington 25, D.C.	(1)
ARDC (RDRS) Andrews AFB Washington 25, D.C.	(1)	U	
AFRD (RRR) Tempo D Building Washington 25, D.C.	(1)	Librarian Boulder Laboratories National Bureau of Standards Boulder, Colorado	(1)
AFRD (AFOSR Library) Tempo D Building Washington 25, D.C.	(1)	U	
WADD (WCOSI) Wright - Patterson AFB, Ohio U	(1)	Division of Scientific Services U.S. Weather Bureau 24th and M. Sts., N.W. Washington 25, D.C.	(1)
AFCRL (CRRELT) LG Hanscom Field Bedford, Massachusetts	(20)	U	
AFCCDD (CCRRG) LG Hanscom Field Bedford, Massachusetts U	(1)	+ ASTIA-TICSCP- Arlington Hall Station Arlington 12, Virginia	(10)
AFIT (Library) Wright - Patterson AFB, Ohio U	(1)	+ (ASTIA will receive: a. <u>NO</u> Restricted Data b. <u>NO</u> Top Secret c. <u>All</u> Confidential d. <u>Most</u> Secret.	
Boston Office Patent and Loyalties Division (Hq AMC) Bldg 133, 424 Trapelo Road Waltham 54, Massachusetts U	(1)	If considered to be highly sensitive, ASTIA will not receive.)	
AWS (AWSSS/TIPD) Scott AFB, Illinois U	(1)	Dr. C.T. Elvey Director Geophysical Institute University of Alaska College, Alaska	(1)
A.U. (Library) Maxwell AFB, Alabama U	(1)	U	

Dr. Joseph Kaplan Department of Physics University of California Los Angeles, California U	(1)	EOARDC Shell Building 47 rue Cantersteen Brussels, Belgium U	(1)
Director, USAF Project RAND The Rand Corporation 1700 Main Street Santa Monica, California Thru A.F. Liaison Office U	(1)	National Research Council 2101 Constitution Avenue Washington 25, D.C. U	(1)
Dr. William w. Kellogg The Rand Corporation 1700 Main Street Santa Monica, California U	(1)	Professor Clarence Palmer Institute of Geophysics University of California Los Angeles 24, California U	(1)
Mr. Malcolm Rigby American Meteorological Society P. O. Box 1736 Washington 13, D.C. U	(1)	Dr. A.M. Peterson Stanford University Stanford, California U	(1)
Dr. David Fultz Department of Meteorology University of Chicago Chicago, Illinois U	(1)	4th Weather Group Andrews AFB Washington 25, D.C.	(1)
Dr. Athelstan Spilhaus University of Minnesota Minneapolis, Minn. U	(1)	9th Weather Group Scott AFB, Illinois	(1)
Institute of Aeronautical Sciences 2 East 64th Street New York 21, New York U	(1)	Climatic Center USAF Annex 2, 225D St., S.E. Washington 25, D.C.	(1)
ACIC (ACEDL) St. Louis 18, Mo. U	(1)	Bauer, Mr. J. Air Proving Ground Center PGVED Eglin AFB, Florida	
Documents Expediting Project (UNITX) Library of Congress Washington 25, D.C. U	(1)	Browne, Mr. R.N. Division 5224 Sandia Corporation Sandia Base Albuquerque, New Mexico	

Cahalan, Mr. Hugh O.
Vitro weapons Service
Air Proving Ground Command
Eglin Air Force Base, Florida

Campbell, Mr. James J.
Naval Ordnance Test Station
Code 3063
China Lake, California

Clement, Mr. Charles A.
Land-Air, Inc.
Box 394
Holloman AFB, New Mexico

Clemente, Mr. J.A.
Pacific Missile Range
Code 3173, Box 7
Point Mugu, California

Commander
Air Force Research Division
Laurence G. Hanscom Field
Bedford, Massachusetts
ATTN: Dr. Robert M. Cunningham,
CRZPC - 1
Aerosol Physics Laboratory

Commander
Air Force Research Division
Laurence G. Hanscom Field
Bedford, Massachusetts
ATTN: Mrs. Rita Callahan Sagalyn
Geophysics Research Directorate
CRZPE

Commander
Air Force Research Division
Laurence G. Hanscom Field
Bedford, Massachusetts
ATTN: Code CRZCO
Mr. Robert Toolin
Geophysics Research Directorate

Commander
Wright Air Development Center
Wright - Patterson Air Force Base
Ohio
ATTN: Captain Caudron

Commander
Wright Air Development Center
Wright - Patterson Air Force Base
Ohio
ATTN: WCLRR, Mr. W.A. Maxim

Commander
Wright Air Development Center
Wright - Patterson Air Force Base
Ohio
ATTN: Mr. Paul Pryor

Coulson, Dr. Kinsell L.
Aerophysics Operation
General Electric Company
3750 "D" Street
Philadelphia 24, Penns.

Dave, Dr. J.V.
Department of Meteorology
University of California
Los Angeles, California

Diamond, Mr. Marvin
U.S. Signal Missile Support Agency
White Sands Missile Range
New Mexico

Director
Langley Research Center
National Aeronautics and
Space Administration
Langley Field, Virginia
ATTN: Mrs. Elizabeth R. Gilman
Librarian

Director
Naval Research Laboratory
Washington 25, D.C.
ATTN: Mr. Robert E. Ruskin
Code 7113
Room 104, Building 30

Dow, Mr. Irving M.
Naval Weapons Plant
Code 730
Washington 25, D.C.

Dunning, Mr. C.E., Snr Engineer
Aerojet - General Corporation
Azusa, California

Evans, Mr. Carroll L. Jr.,
Code 3041
U.S. Naval Ordnance Test Station
China Lake, California

Fava, Lt. Col. James A. USAF
Code RRRO
Air Force Research Division
Tempo X
Washington 25, D.C.

Goetz, Dr. Alexander
California Institute of Technology
Pasadena, California

Hembree, Mr. Ray V.
NASA Marshall Space Flight Center
ATTN: M-RP-P
Huntsville, Alabama

Hengst, Mr. Gerhard A.
Atlantic Missile Range
ATTN: MTLDO
Patrick AFB, Florida

Hones, Mr. Edward W.
Mail Zone 6-172
Consolidated Vultee Aircraft Corp.,
San Diego, California

Human Factors Branch
Research Division, RD-130
NAFEC
Atlantic City, New Jersey

Human Factors Section
Mail Station 4R101
Sperry Gyroscope Company
Great Neck, New York

Kasten, Dr. Fritz
University of Mainz
Institute of Meteorology and Geophysics
Mainz, Germany

Kinder, Mr. Floyd (Vice Chairman)
Naval Ordnance Test Station
Code 3041
China Lake, California

Lenoble, Dr. Jacqueline
43 rue Cuvier
Laboratoires de Physique du Museur
Paris 5e, France

Ludwig, Mr. Robert
Research Dept. - Engineering College
New York University
401 West 205 Street
New York 34, New York

Mantey, Mr. W.F.
Air Proving Ground Center
PGVED
Eglin AFB, Florida

Markham, Mr. Keith G. (Secretary)
Air Force Flight Test Center
Space Positioning Branch
FTFSSE
Edwards AFB, California

McDonald, Mr. Richard K.
Boeing Airplane Company
Aero Space Division
P.O. Box 3707,
Seattle 24, Washington

Mendoza, Mr. Barry A.
3206 Annrae Street
San Diego 11, California

Middleton, Dr. W.E.K.
National Research Council
Ottawa 2, Ontario, Canada

Mimmack, Mr. William
IRM-RID-0
White Sands Missile Range
New Mexico

Missert, Dr. Ray
Cornell University Research Organization
Buffalo, New York

Montague, Capt. George H.
6511th Test Group (Parachute)
Box 65 ALF
El Centro, California

Parsons, Mr. Dan
Section 5224-1
Sandia Corporation
Sandia Base
Albuquerque, New Mexico

Moyer, Mr. Paul M.
Wright Air Development Division
Flight and Test Engineer
WCUP-Area 13, Building 601
Wright - Patterson AFB, Ohio

Pezzuto, Mr. A.M.
Bendix Corporation
P.O. Box 2093
Oxnard, California

Muhleisen, Prof. Dr. R.
Max-Planck-Institut für Aeronomie
Institut für Stratosphären-Physik
14b) Weissenau b. Ravensburg
Germany

Price, Mr. William A.
Atlantic Missile Range
RCA Mail Unit 511
Patrick AFB, Florida

Mullis, Mr. C.W.
IRM-P
Integrated Range Mission
White Sands Missile Range
New Mexico

Robinson, Mr. John E. Jr.
Applied Psychology Corporation
4113 Lee Highway
Arlington 7, Virginia

Murray, Mr. R.P.
Staff Photographic Office (WDEF)
Hq Ballistic Missile Division (ARDC)
Air Force Unit Post Office
Los Angeles 45, California

Rosanno, Dr. A.T.
California Institute of Technology
Pasadena, California

Nader, Mr. John S. Chief
Instrumentation
Air Pollution Engineering Research
Robt. A. Taft Sanitary Eng. Center
Cincinnati 26, Ohio

Russell, Mr. William C.
IRM-MDS-CI
White Sands Missile Range
New Mexico

O'Halloran, Mr. G.T.
Bendix Research Laboratory Division
P.O. Box 5115
Detroit 35, Michigan

Sanders, Mr. Tom
Code 3145
Geophysical Branch-Systems Division
Range Development Department
Naval Missile Center
Point Mugu, California

Oliver, Mr. John L.
Land-Air Inc., R and D
P.O. Box 394
Holloman AFB, New Mexico

Schepler, Mr. H.C.
Space Technology Labs, Inc.,
Box 95001
Los Angeles 45, California

Orr, Mr. Richard L.
Booz-Allen Applied Research Inc.,
408 West Main Street
Fairborne, Ohio

Southard, Mr. D.J.
Hq. U.S. Army Ordnance Missile Command
ATTN: ORDXM-DP
Redstone Arsenal, Alabama

Van Buskirk, Mr. L.F.
Naval Ordnance Test Station
Code 3043
China Lake, California

Strandberg, Lt. Col. E.R.
Staff Photographic Office (WDEF)
Hq Ballistic Missile Div. (ARDC)
Air Force Unit Post Office
Los Angeles 45, California

Van Dyke, Mr. H.A.
Pacific Missile Range
Code 3170, Box 7
Point Mugu, California

Swain, Mr. J.B.
Particle and Wave Optics Eng.
Room 213, Building 37
General Electric Laboratories
General Electric Company
One River Road
Schenectady 5, New York

White, Mr. John A.
Air Proving Ground Center
PGVEP
Eglin AFB, Florida

Swelgart, Mr. David J.
Army Rocket and Guided Missile Agency
Redstone Arsenal
Huntsville, Alabama

Woehl, Mr. Walter E.
Air Force Missile Development Center
ATTN: MDWO
Holloman AFB, New Mexico

Tasis, Mr. E.
Guided Missile Range Division
Pan American World Airways
Mail Unit 841
Patrick AFB, Florida

Dept. of the Army (SIGRD-8-B-5)
Washington 25, D.C. (1)

Taylor, Mr. Albert E. (Chairman)
Air Force Flight Test Center
Aerospace Data Facilities Office
FFPSA
Edwards AFB, California

Technical Documents Center
Evans Signal Laboratories
Belmar, New Jersey (1)

Thompson, Dr. Moody C. Jr. Chief
Lower Atmosphere Physics Section
Radio Propagation Eng. Division
Central Radio Propagation Laboratory
Boulder Laboratories,
National Bureau of Standards
Boulder, Colorado

ONR (Geophysics Code N-416)
Office of Naval Research
Washington 25, D.C. (1)

Naval Research Laboratory
(Code 2021)
Washington 25, D.C. (1)

Timko, Mr. G.B.
Pacific Missile Range
Code 3275, Box 8
Point Mugu, California

U.S. Postgraduate School
(Library)
Monterey, California
U (1)

OTS (Tech. Reports Section)
U.S. Dept. of Commerce
Washington 25, D.C.
U (2)

Science Advisor Department of State Washington 25, D.C. U	(1)	Library University of California Scripps Institution of Oceanography San Diego, California	(1)
Superintendent of Documents Government Printing Office Washington 25, D.C. U	(1)	Oceanographic Publications University of California Scripps Institution of California San Diego, California	(1)
Library NASA Washington 25, D.C.	(1)	Publications Office 101 University Hall 2200 University Avenue Berkeley 4, California	(2)
Library U.S. Weather Bureau Suitland, Maryland U	(1)	Office of Technical Services Department of Commerce Washington 25, D.C.	(1)
FAA National Aviation Facilities Experimental Center Atlantic City, New Jersey U	(1)	Department of the Navy Office of Naval Research, Branch Office London, Navy 100, Box 39 F.P.O. New York, New York ATTN: Maria Sachs, Technical Information Specialist	(1)
Prof. Fred. L. Whipple Harvard College Observatory 60 Garden Street Cambridge, Mass. U	(1)	Visibility Laboratory File Copy	(1)
Chief, Bureau of Ships Navy Department Attn: Code 312 Washington 25, D.C.	(10)	Visibility Laboratory Technical Documents (Reading File)	(2)
Chief, Bureau of Ships Navy Department Attn: Code 342C Washington 25, D.C.	(2)		
Commanding Officer and Director U.S. Navy Electronics Laboratory Attn: Code 2000 San Diego 52, California	(4)		