

Visibility Laboratory  
University of California  
Scripps Institution of Oceanography  
San Diego 52, California

CONTRAST THRESHOLDS AS A FUNCTION OF RETINAL POSITION  
AND TARGET SIZE FOR THE LIGHT-ADAPTED EYE

John H. Taylor

March 1961  
SIO REFERENCE 61-10  
AF Project 7621-Task 76222

Bureau of Ships  
Contract NObs-72092  
Project S FO01.05'01

Approved:

Approved for Distribution:

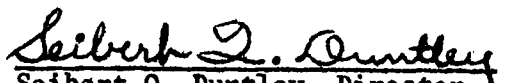
  
Seibert Q. Duntley, Director  
Visibility Laboratory

  
Roger Revelle, Director  
Scripps Institution of Oceanography

SUMMARY

Binocular visual thresholds for targets of several sizes and occupying various positions in the visual field have been measured at photopic adaptation luminance. Circular targets of positive contrast were presented for 0.33 second, chosen as a duration typical of the dwell times used in normal visual search procedures. Four young male observers with normal vision were used as subjects for the experiment. The data, based on approximately 80,000 observations, exhibit the dependence of the visual contrast threshold upon target size and position.

The findings of the study differ, as anticipated, from other data which relate to the case of very brief (10 millisecond) target flashes, and are believed more suitable than the latter for the construction of visibility lobes used in the prediction of sighting ranges. The roles of various factors such as retinal neuroanatomy and eye-movement have been suggested, and intercomparison between studies has been attempted in an effort to evaluate these factors as determinants of visual performance.

CONTRAST THRESHOLDS AS A FUNCTION OF RETINAL POSITION  
AND TARGET SIZE FOR THE LIGHT-ADAPTED EYE

John H. Taylor

Scripps Institution of Oceanography, University of California  
La Jolla, California

INTRODUCTION

Contrast thresholds for the human eye using central vision at photopic levels of adaptation luminance have been systematically investigated and reported in the contemporary literature (e.g., Blackwell, 1946). Further, the change of threshold with changing position of the target on the retina has been investigated for very brief targets ( $t = 0.01$  second) subtending 1 minute of arc, and described by Blackwell and Moldauer (1958). Several other investigators have published data to this point, but these studies, by and large, have not been sufficiently comprehensive in their coverage of both the size and positional parameters to be of direct concern to the present study.

For some time a clear need has been felt for visual response data which would enable the solution of certain problems in human visual search. It is apparent that the human observer, in searching, say, the ocean for a surface vessel or the sky for an aircraft (as in visual collision avoidance), will hardly employ a dwell time as brief as ten milliseconds. Nor will he enjoy the leisurely

rates of search to which the long-duration data apply. It is to the case of the more usual search situations that the present study was addressed; when the observer may be expected to direct his gaze in such a way that binocular dwell times are most likely to be of the order of one-third of a second. Additionally, it was felt that the data should relate to a variety of target sizes, since the manner in which spatial summation of visual excitation occurs for targets in the peripheral visual field is only imperfectly known at present, based primarily upon the important paper of Graham and Margaria (1935). Other insights into the neural mechanisms involved in peripheral vision may be sought in the data of Øesterberg (1935), which remain our best indication of the relative densities of retinal cones in different parts of the eye, and the recent data concerning the small and rapid oscillatory eye-movements described by Adler and Fliegelman (1934) and shown to play an important role in vision by Riggs et al., (1954), Ditchburn and Ginsborg (1953), and others. Both these temporal integrative effects and the spatial ones previously mentioned may be important to the detection of peripheral targets in human visual search.

Until the present time, the science of visibility calculation and prediction has had to depend upon the gradients of retinal sensitivity used by Lamar (1948), derived from the data of Craik, or upon some modification of these based upon the results of Blackwell and Moldauer (1958). But the application of data which refer,

rigorously speaking, only to point sources of light at one one-hundredth of a second, was thought to be inadmissible in the context of realistic search situations. Accordingly, it was necessary to investigate the dependence of detection threshold upon their position in the visual field, and for a number of reasonable target sizes.

Very many of the emergent problems in which visual search must be evaluated, and its capabilities and limitations assessed, concern the case of high adapting luminance -- the daytime case. The problems of daytime collision avoidance in civil aviation, the search for downed aviators on the ocean surface during daylight hours, and the detection of hazardous objects during navigation in fog are all typical of situations for which more directly applicable visual performance data are urgently needed. An obvious corollary of this fact is that the development of an efficient search doctrine will be possible only to the extent that the data used for the purpose are appropriate.

The present study was undertaken in order to extend our knowledge of the detectability of targets in the near periphery of the visual field, and for target situations which are considered to be more typical of anticipated search requirements.

METHOD

Subjects. -- Four young emmetropic male observers were used in the study. All were highly trained in laboratory observation of a variety of visual targets, and their visual performance characteristics were, therefore, well documented in a number of visual tasks. Owing to the "professional" status of these subjects, it was unnecessary for them to undergo formal training for the present experiments. None exhibited measureable refractive error at the observing distance used. All observers completed all target runs, although the order and spacing of these runs were commonly different for each, according to scheduling necessities.

Apparatus. -- A uniformly bright adapting field, square, and subtending  $50^\circ$  on a side, confronted the observers at a distance of 36 inches. The luminous surface consisted of thin, translucent milk plastic which had been reduced in gloss by an abrasive treatment. The plastic was chosen on the basis of its ability to transmit a projected image without appreciable loss in edge definition, its approximately neutral spectral transmittance, and its freedom from transmission or reflection non-uniformities. This plastic, tightly stretched upon a reinforced wooden frame, formed one side of a cubical integrating cavity containing a number of tungsten lamps. The lamps were selected to yield the desired screen luminance at an apparent color temperature of  $2360^\circ\text{K}$ . The inner surfaces

of the integrator, excepting the plastic one, were coated with a high-reflectance neutral white paint of the sort used in photometric integrating spheres. The rear wall of the cube was pierced by a circular hole through which targets could be projected onto the center of the rear surface of the plastic and presented to the subject by transillumination.

The target projector consisted of a modified standard  $3\frac{1}{4} \times 4$ " slide projector. Circular targets of uniform luminance were produced by the use of small circular stops placed either at the usual slide position or at the exit pupil of the projection lens. The source was a selected tungsten projection lamp which had been cured in accordance with accepted photometric procedure in order to obviate changes in output during a single experimental session. Heat absorbing filters were removed so that an acceptable color temperature match to the background could be realized. A rotary shutter driven by a synchronous motor and consisting of two coaxial sector wheels was placed just in front of the lens, followed by a solenoid-operated flag shutter which could be opened to allow a single brief flash to reach the screen. In front of the shutters was mounted a cell which could hold calibrated  $4 \times 4$ " glass-mounted Wratten neutral density filters used to reduce the target luminance to near-threshold range. The final element in the projection system was a wheel with six apertures, any one of which could be aligned with the optical axis. One aperture was an open hole, four contained

neutral density filters, similar to the fixed filters already mentioned, and the sixth was closed by an opaque plate. This wheel, accordingly, could be said to have borne a series of six filters with transmission values: 1.000, 0.738, 0.494, 0.303, 0.200, and zero.

Two different arrangements were used in producing the targets. For the larger sizes studied (120' and 15'), the stimulus was projected through the rear hole in the integrating box and focussed directly onto the plastic screen in the manner described above. This system is diagrammed in Figure 1. For targets of smaller angular extent (3.6', 1.74', and 1.0'), it was found convenient to generate the stimuli by reflection. A thin plano-convex lens of spectacle crown glass ( $n = 1.523$ , radius of curvature  $\approx 3.5''$ ) was affixed to the center of the screen with clear cement. The projection apparatus was moved to a position behind the observer, a circular aperture of such a size that its image would fall entirely within the lens was placed in the slide position, and a second circular aperture (which governed the apparent size of the target) was placed at the exit pupil of the projector objective. This arrangement may be seen in Figure 2. The observer sees, then, a demagnified image of aperture A by reflection in the convex surface of the thin lens L. The angular size of the target, then, is given by the formula:

$$\text{Visual Angle} = A \times \frac{R \times \cos \alpha / 2}{2 \times d} \times \left( 1 - \frac{R \times \cos \alpha / 2}{2 \times d} \right) \times \frac{3436}{D}$$

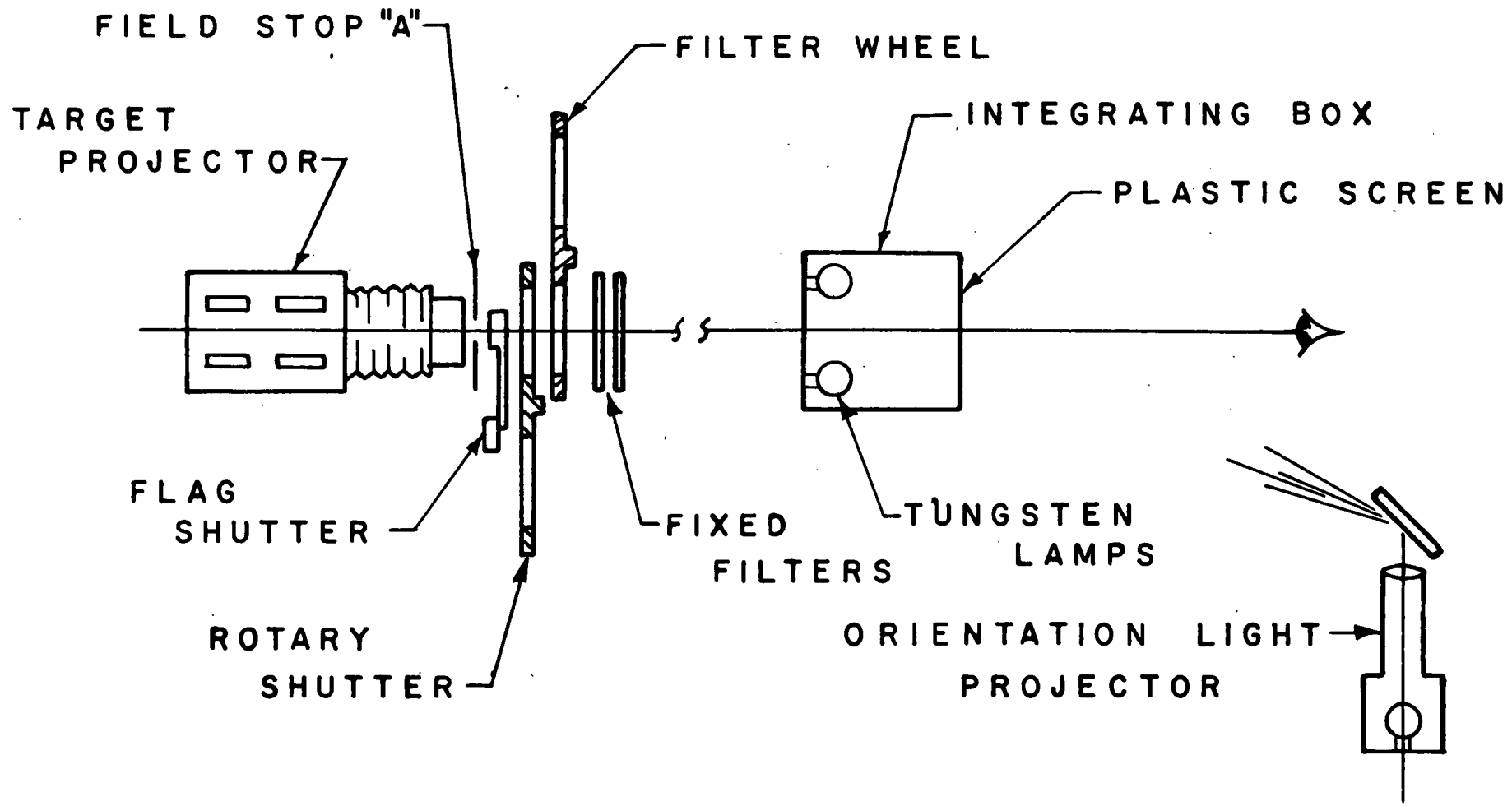

Figure 1. Optical System Used in Projecting Targets by Direct Projection

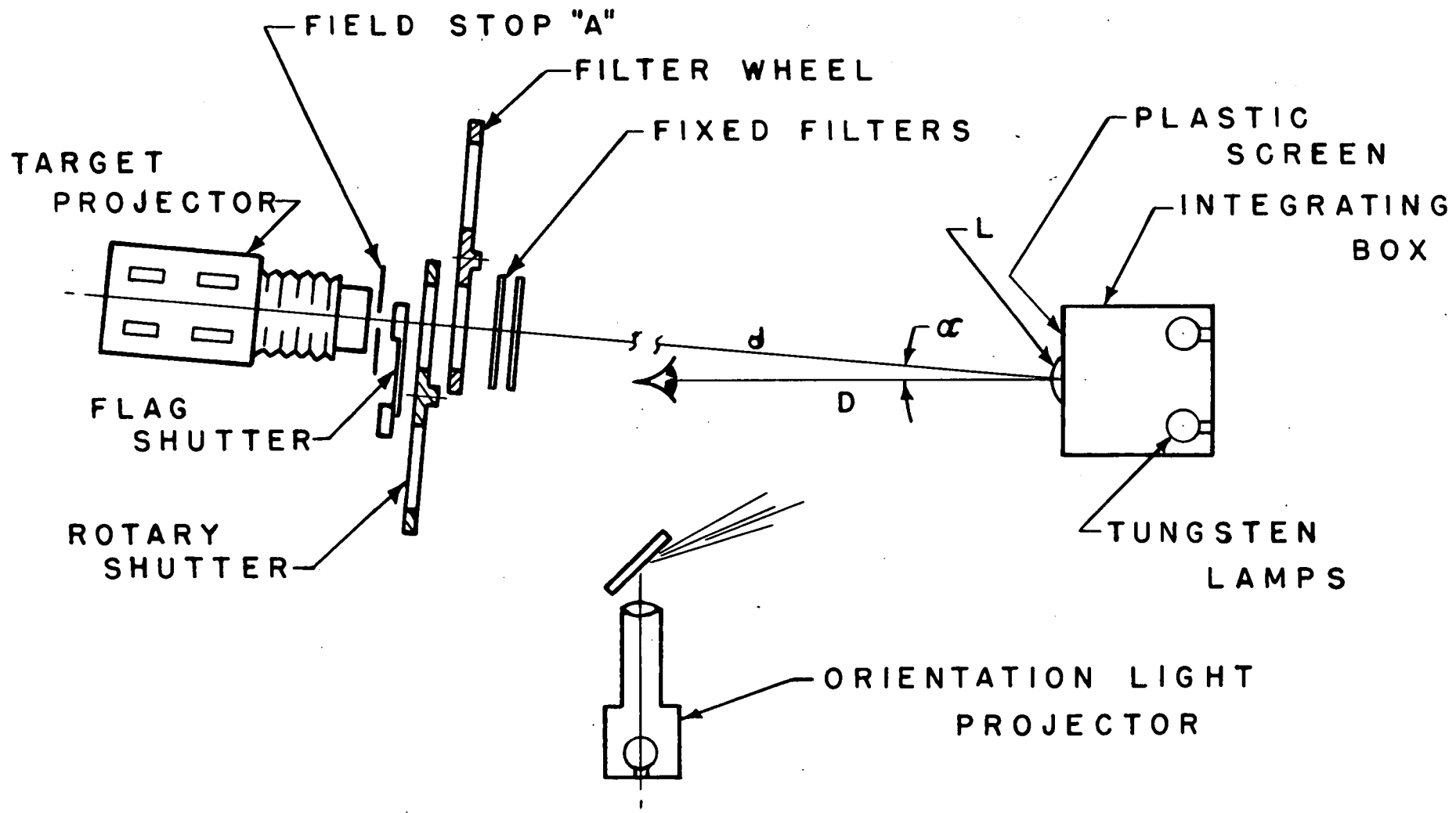

Figure 2. Optical System for Generating Small Targets by Reflection from a Convex Lens

where:

A = Diameter of the projector exit pupil

R = Radius of curvature of convex lens, L

D = Distance from L to observer's eye

d = Distance from projector exit pupil of lens L

$\alpha$  = Angle between projector axis and visual axis.

The radius of curvature of L must be sufficiently small so that the apparent image of the target is not appreciably displaced behind the plastic screen.

Orientation and accommodation cues were provided by projected small, dim (about 10 x threshold) spots from an ancillary projector located just behind the observer, as shown in Figures 1 and 2.

Central stimuli were presented at the center of a constellation of four of these orientation lights, and peripheral ones were presented at various angular distances from a single spot toward which the observer directed his vision. The orientation spots subtended approximately one minute of arc at the eyes, and were kept at a minimum of 18 minutes from the nearest target edge in order to avoid influencing the threshold for the stimulus proper.

Photometric procedures. — Photometry of both targets and background was accomplished by use of a Macbeth illuminometer, calibrated against secondary standard lamps at color temperature 2360°K obtained from the Bureau of Standards, and using various accessory

attachments made and calibrated at the Visibility Laboratory. Large targets (those generated by direct projection through the rear of the plastic screen) were measured directly with the illuminometer, either alone or by the use of a calibrated macroscopic accessory. Photometry of the targets seen by reflection proceeded by a method somewhat analogous to the determination of visual angle described above. A standard plaque of known reflectance was placed at the position of the front surface of Lens L (Figure 2), and its luminance was measured. From the luminance so obtained, and the known reflectance of the plaque, the illumination incident upon the lens may be computed; so also the effective candle-power of the projection system, and the value of illumination reaching the observer's eye ( $\Delta E$ ) by the following formula:

$$\Delta E = \frac{E \times d^2 \times m^2 \times r}{D^2}$$

where:

D = Distance from reflecting lens L to observers eye, in feet

d = Distance from L to projector lens, in feet

r = Reflectance of lens L (0.042)

E = Illumination at reflecting lens L

m = Magnification of lens L.

In all cases the photometry was done for the unattenuated output of the projector. The conversion to the actual levels used was based upon the calibration of the Wratten neutral density filters,

accordingly, this calibration was done to a high degree of accuracy on a three-meter photometric bench, using the filters in a manner similar to their subsequent use in the experiment. These calibrations, performed before commencing the experiment and again at its conclusion, showed no change in transmission values beyond expected statistical sampling error.

Experimental method. — The targets were presented randomly at five contrast levels as governed by the transmissions of the wheel filters. Catch trials were randomly interspersed in the series by interposition of the opaque plate. Each experimental subsession consisted of 240 presentations, or forty at each contrast level. The five finite contrast levels were preselected to yield frequencies of seeing from nearly zero to nearly 100 per cent. The transmission values chosen for the wheel filters were found, in combination with the fixed filters, to bracket the detection range of the observers in most cases. The observers were alerted to the time of target appearance by a buzzer which sounded during the time that the solenoid-operated shutter was held open to allow passage of a flash. By use of a cam and switch attachment to the rotary timer shaft it was possible to cause the flash to occur at about the midpoint of the period during which the buzzer was heard. The observers responded "yes" when the target was seen; "no" when it was not. Positive responses to the catch trials were used in correcting the obtained proportions of positive responses

to real targets, (although this was rarely necessary for these highly trained observers) by use of the following formula:

$$P = \frac{P' - C}{1 - C}$$

where P is the corrected proportion, P' the obtained proportion, and C the obtained proportion of false positive responses. Every target situation was observed in three subsessions by each observer, so that a total of 79,200 trials are represented by the data, excluding catch trials.

### RESULTS

Form of the data. -- Data from each experimental subsession were tabulated for each observer, corrected for false positives if necessary, and plotted as proportions of positive responses as a function of target contrast. Contrast is here defined conventionally as the ratio of the target increment to the prevailing background luminance. These corrected proportions were used in estimating a contrast value which would result in a fifty per cent probability of seeing (the contrast threshold) for each subsession. Obtained frequencies were not averaged between subsessions since it was frequently impossible for the observers to run three subsessions sequentially. Calculated values of threshold contrast were, however, averaged. The psychophysical functions from which the threshold

values were derived were either normal or logarithmic Gaussian integrals, fitted to the data point by use of the probit analysis technique devised by Finney (1947) as modified for computer use by Richardson (1960). All data were reduced by a Burroughs ~~20~~<sup>30</sup> computer at the U.S. Navy Electronics Laboratory, San Diego.

The average values of threshold contrast obtained from four observers are presented in Table I.

TABLE I

TARGET ECCENTRICITY	TARGET SIZE (MINUTES OF ARC)				
	1.00	1.74	3.60	15.0	120
0	.539	.196	.0488	.0162	.00780
1.25	.772		.0793	.0214	.00921
2.50	1.39	.386	.0960	.0240	
5	2.75	.786	.218	.0356	.0121
7.5	3.72	1.03	.278	.0465	.0127
10	4.55	1.48	.333	.0557	.0135
12.5	5.73	1.69	.545	.0725	.0154

Complete results of the experiment will appear as a supplement to this report. The complete results give the following values for each experimental sub-session:

$C_t$  -- The threshold contrast ( $p = .50$ )

$\sigma_t$  -- The standard deviation of the threshold

$b$  -- The slope of the psychophysical function

$\sigma_b$  -- The standard deviation of the slope

$X^2$  -- The value of Chi-square

$P(X^2)$  -- The cumulative Chi-square probability (an index of the goodness of fit),

as well as an indication of the type of function (logarithmic or normal) which was found to give the more satisfactory fit. For a discussion of curve fitting by normal and logarithmic ogives (as well as by other curves) see, for example, Blackwell (1953).

The form of the data may best be seen in Figure 3, which shows the means of the obtained threshold contrast values as a function of position in the visual field, for each of the five target sizes studied. The individual data points of this figure are averages of the threshold contrast values for four observers, each condition having been replicated three times; hence each plotted experimental point represents results from 2400 observations, excluding catch trials. Continuous curves have been drawn through the data points for each of the target sizes.

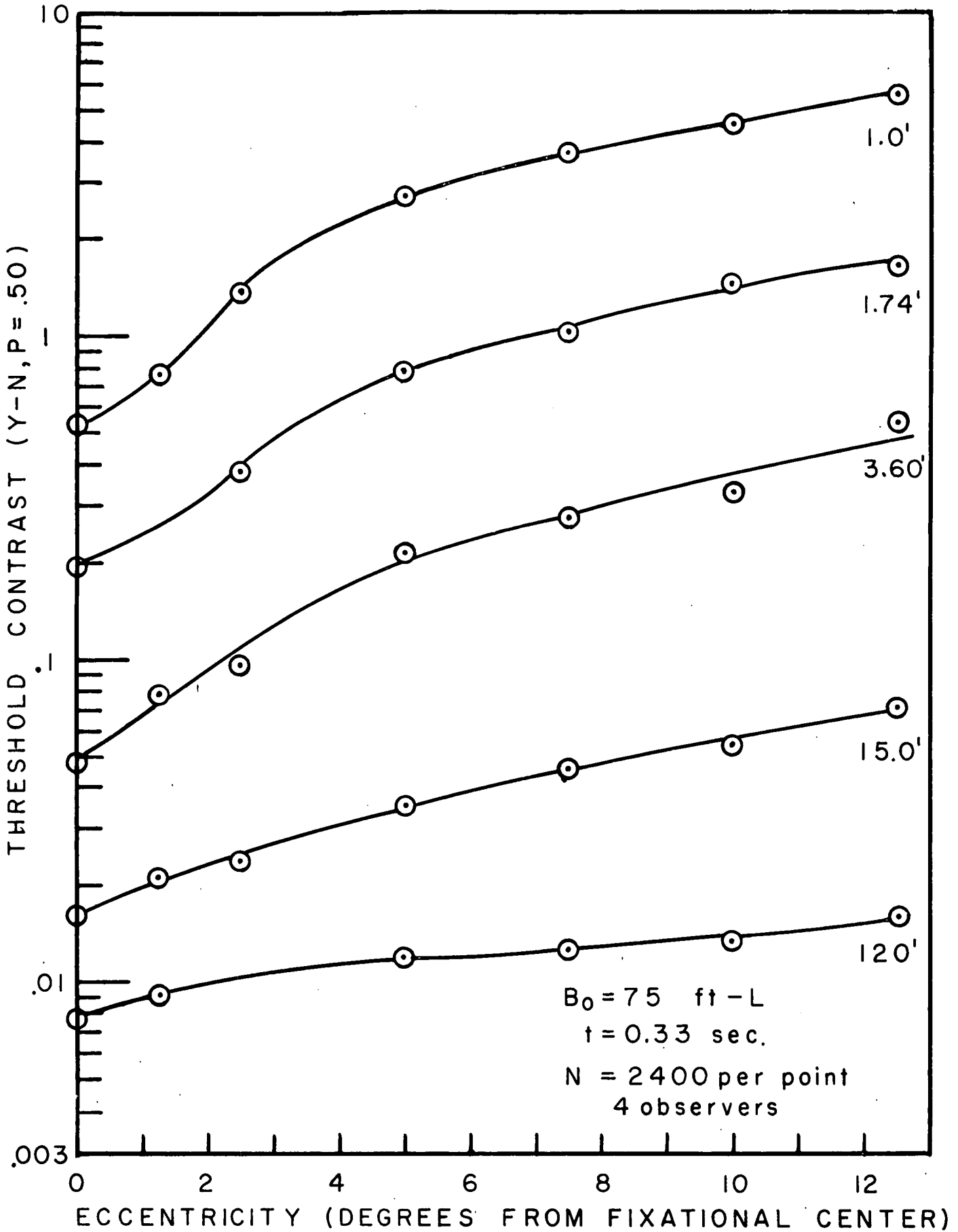

Figure 3. Contrast Threshold as a Function of Position in the Visual Field for Five Sizes of Circular Targets

### DISCUSSION

The data reported in this study relate to the case of brief, but not ultra-short target durations. No attempt was made, for example, to use presentation times short enough to eliminate the assumed integrating effects of the very rapid (circa 30-50 per second) component of normal spontaneous oscillatory eye movements. Thus, the results are intended to indicate the dependence of contrast threshold value upon target size and position in the binocular visual field for the ordinary case (e.g., in visual search) involving glimpse or dwell times around a third of a second. Under these conditions, it might be expected that the probability of detecting a target of a particular size and location will be determined, other things being equal, by the following factors:

1. The number and kind of retinal receptor elements present, and their momentary thresholds,
2. The operating diffuse receptor interconnections,
3. The frequency and angular extent of eye-movements,
4. The duration of the target.

It is unfortunate that, to date, the omnibus experiment which might separate and assess these factors remains to be done. Such an experiment, rigorously contrived, would incorporate facilities for controlled movement of the retinal images, in addition to the usual variables. Until such an experiment may be performed, it is necessary to piece together bits of evidence from the few systematic

studies presently available. Differences in experimental method, observers, small numbers of observers, and similar difficulties make the intercomparison between the results of various investigators a highly speculative exercise. Nonetheless, owing to the striking differences between the data of the present investigation and those of Blackwell and Moldauer (1958) upon which much of the current thinking about search probability has been based, it is probably worthwhile to compare the two sets of results.

Direct comparison of our data with those of Blackwell and Moldauer (1958) is possible only for the targets subtending one minute of visual angle, and for the 75 foot-lambert adapting luminance. If one makes the rather cavalier assumption that the values of threshold contrast differ at the central location (zero degrees eccentricity) only because of the differences in observers, target duration, and psychophysical method, and that the curve shapes differ only by reason of the different durations used, than a comparison is possible. Our data have been multiplied by a constant factor of 4.44 in order to equate them with the Blackwell and Moldauer results at the center of the visual field, and the two curves have been plotted in Figure 4. The divergence of the curves suggest that the increase in threshold contrast with greater eccentricity is considerably less with longer target durations. This is hardly a surprising result if one assumes that the probability of detecting a very small target in the periphery will increase if, by reason of eye-movement, the target image is caused to sweep over a palpable

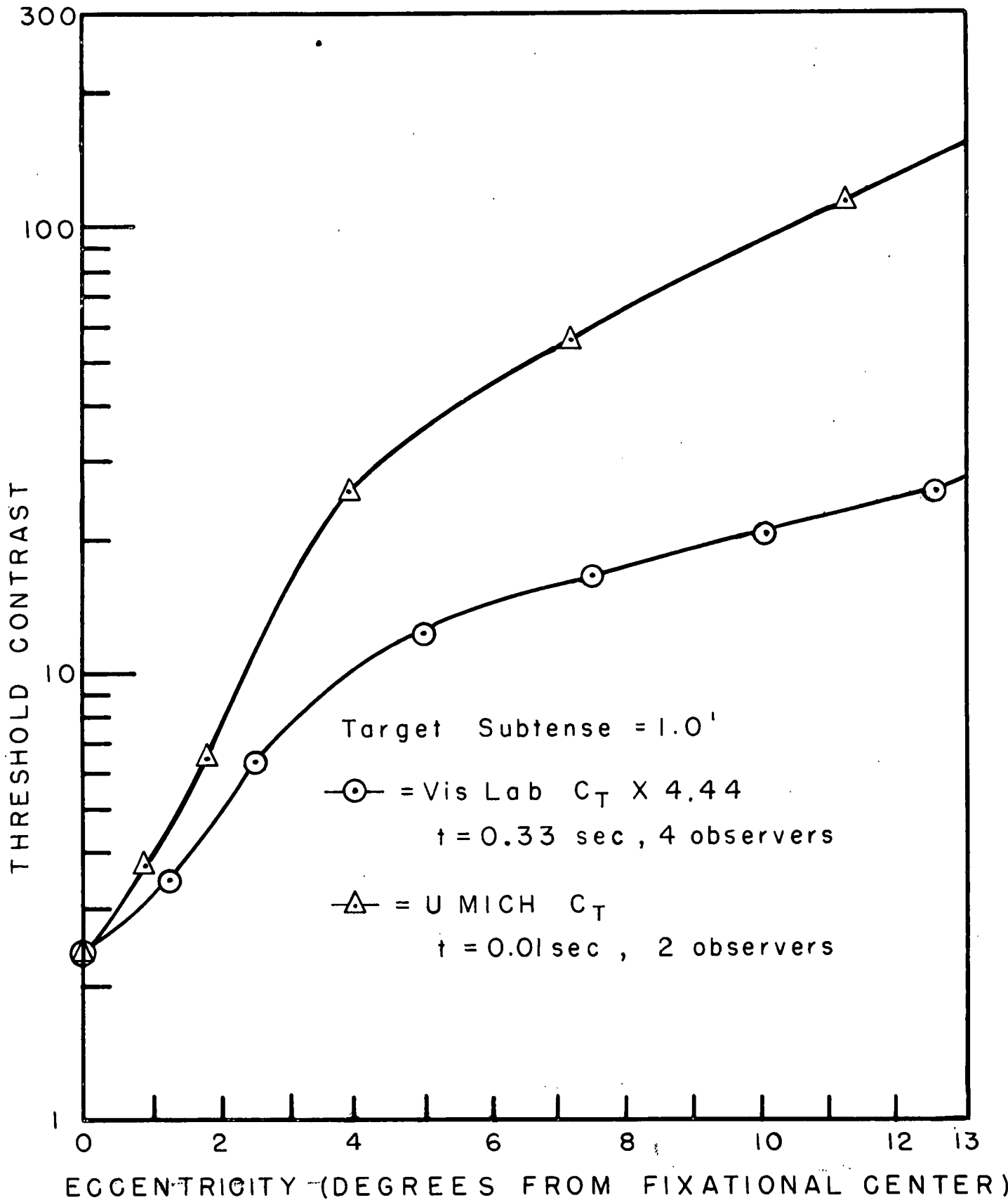

Figure 4. Comparison of the Data of the Present Study with those of Blackwell and Moldauer (1958), Equated at 0° Eccentricity to Show Shape Differences between 0.01 Second and 0.33 Second Target Durations

area of the retina, or to increase by reason of some simple temporal integration. The known manner in which cones are distributed over the retina, and the experimental findings which relate visual acuity to eccentricity are both highly suggestive in the context of the present study. At present we are engaged in trying to relate those findings relating visual performance to position in the visual field to the facts of neuroanatomy, dynamic eye-movements, and photochemistry.

REFERENCES

- Adler, F. H. and Fliegelman, M., Influence of Fixation on the Visual Acuity. Arch. Opth., Chicago, 1934, 12, 475-483
- Blackwell, H. R., Contrast Thresholds of the Human Eye, J. Opt. Soc. Am., 1946, 36, 624-643.
- Blackwell, H. R., Studies of the Form of Visual Threshold Data, J. Opt. Soc. Am., 1953, 43, 456-463.
- Blackwell, H. R. and Moldauer, A. B., Detection Thresholds for Point Sources in the Near Periphery, USN BuShips Contract NObs-72038, Index No. 714-100, University of Michigan Engineering Research Institute Project 2455, June 1958.
- Ditchburn, R. W. and Ginsborg, B. L., J. Physiol., 1953, 119, 1 ff.
- Finney, D. J., Probit Analysis, Cambridge: Cambridge University Press, 1947.
- Graham, C. H. and Margaria, R., Area and the Intensity Time Relation in the Peripheral Retina, Amer. J. Physiol., 1935, 113, 299-305.
- Lamar, E. S., Visual Detection in Air Interception, OEG Study 368, 24 November 1948.
- Øesterberg, G., Topography of the Layer of Rods and Cones in the Human Retina, Acta Ophthalmologica, Suppl. Vol. 61, 1935, 1-102.
- Richardson, W. H., An Adaptation of the Method of Probit Analysis to Psychophysical Threshold Data, USN BUSHips Contract NObs-72092, University of California, Visibility Laboratory, Scripps Institution of Oceanography, Reference SIO 60-47, 1960.
- Riggs, L. A., Armington, J. C. and Ratliff, F., Motions of the Retinal Image During Fixation, J. Opt. Soc. Am., 1954, 44, 315-321.