

SECURITY CLASSIFICATION OF THIS PAGE (When Data Entered)

REPORT DOCUMENTATION PAGE		READ INSTRUCTIONS BEFORE COMPLETING FORM								
1. REPORT NUMBER AFGL-TR-77-0078	2. GOVT ACCESSION NO.	3. RECIPIENT'S CATALOG NUMBER								
4. TITLE (and Subtitle) AIRBORNE MEASUREMENTS OF ATMOSPHERIC VOLUME SCATTERING COEFFICIENTS IN NORTHERN EUROPE, SPRING 1976		5. TYPE OF REPORT & PERIOD COVERED Scientific - Interim Scientific Report No. 7								
		6. PERFORMING ORG. REPORT NUMBER SIO Ref. 77-8								
7. AUTHOR(s) Seibert Q. Duntley Richard W. Johnson Jacqueline I. Gordon		8. CONTRACT OR GRANT NUMBER(s)  F19628-76-C-0004								
9. PERFORMING ORGANIZATION NAME AND ADDRESS University of California, San Diego Visibility Laboratory San Diego, California 92152		10. PROGRAM ELEMENT, PROJECT, TASK AREA & WORK UNIT NUMBERS DoD Element 6210F Project, Task, Work Unit No. 7621-11-01								
11. CONTROLLING OFFICE NAME AND ADDRESS Air Force Geophysics Laboratory Hanscom AFB, Massachusetts 01731 Contract Monitor: Major Cress/OPA		12. REPORT DATE March 1977								
		13. NUMBER OF PAGES 151								
14. MONITORING AGENCY NAME & ADDRESS (if different from Controlling Office)		15. SECURITY CLASS. (of this report)  UNCLASSIFIED								
		15a. DECLASSIFICATION/DOWNGRADING SCHEDULE								
16. DISTRIBUTION STATEMENT (of this Report)  Approved for public release; distribution unlimited.										
17. DISTRIBUTION STATEMENT (of the abstract entered in Block 20, if different from Report)										
18. SUPPLEMENTARY NOTES										
19. KEY WORDS (Continue on reverse side if necessary and identify by block number)										
<table> <tbody> <tr> <td>Albedos</td> <td>Natural Daytime Irradiance</td> </tr> <tr> <td>Atmospheric Optical Properties</td> <td>Temperature Profile</td> </tr> <tr> <td>Atmospheric Scattering Coefficient</td> <td>Relative Humidity Profile</td> </tr> <tr> <td>Atmospheric Beam Transmittance</td> <td></td> </tr> </tbody> </table>			Albedos	Natural Daytime Irradiance	Atmospheric Optical Properties	Temperature Profile	Atmospheric Scattering Coefficient	Relative Humidity Profile	Atmospheric Beam Transmittance	
Albedos	Natural Daytime Irradiance									
Atmospheric Optical Properties	Temperature Profile									
Atmospheric Scattering Coefficient	Relative Humidity Profile									
Atmospheric Beam Transmittance										
20. ABSTRACT (Continue on reverse side if necessary and identify by block number)										
<p>This report presents daytime atmospheric optical data collected chiefly with airborne instruments during a field expedition to northern Europe in the spring of 1976. Results from eight flights are presented. The data include the natural irradiance upon horizontal plane surfaces, total volume scattering coefficients, atmospheric beam transmittances. Data for daytime conditions ranging from relatively clear and cloud free to completely overcast are presented. Data were measured in four spectral regions, as follows: Three narrow band optical filters with mean wave-</p>										

20. ABSTRACT continued:

lengths of 478, 664, and 765 nanometers; and one broad band sensitivity representing a pseudo-photopic response with a mean wavelength of 557 nanometers.

Selected meteorological properties, measured concurrently with the radiometric data are also included.

**AIRBORNE MEASUREMENTS OF ATMOSPHERIC VOLUME SCATTERING  
COEFFICIENTS IN NORTHERN EUROPE, SPRING 1976**

Seibert Q. Duntley, Richard W. Johnson, and Jacqueline I. Gordon

Visibility Laboratory  
University of California, San Diego  
Scripps Institution of Oceanography  
San Diego, California 92152

Approved:

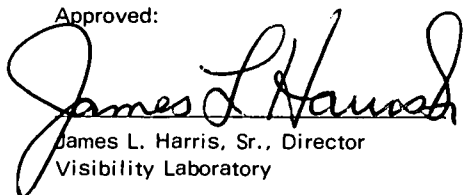
  
James L. Harris, Sr., Director  
Visibility Laboratory

Approved:

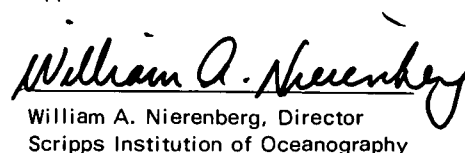
  
William A. Nierenberg, Director  
Scripps Institution of Oceanography

**CONTRACT NO. F19628-76-C-0004**

**Project No. 7621**  
**Task No. 7621-11**  
**Work Unit No. 7621-11-01**

**Scientific Report No. 7**  
**March 1977**

**Contract Monitor**

**Major Ted S. Cress, Atmospheric Optics Branch, Optical Physics Division**

Approved for public release; distribution unlimited.

Prepared for  
AIR FORCE GEOPHYSICS LABORATORY  
AIR FORCE SYSTEMS COMMAND  
UNITED STATES AIR FORCE  
HANSCOM AFB, MASSACHUSETTS 01731

## SUMMARY

This report, which describes portions of the Visibility Laboratory's Project OPAQUE I\* effort, was prepared under AFGL Contract F19628-76-C-0004. The principal project task was to take daytime atmospheric optical measurements in northern Europe and, from these measurements, to determine optical properties for various upward- and downward-inclined paths of sight. These properties include the natural irradiance upon horizontal plane surfaces, scalar irradiances, total volume scattering coefficients, atmospheric beam transmittances, path radiances, directional path reflectances, and directional sky and terrain reflectances. This report does not contain all of these optical properties, but in an effort to accelerate the availability of selected values, we have restricted the data to total volume scattering coefficients, atmospheric beam transmittances, and natural irradiances upon horizontal plane surfaces. The data base for the derivation of the additional, more directional optical properties is available on tape and can be exploited upon demand. Selected meteorological properties measured concurrently with the radiometric data are also included.

The OPAQUE I field trip was made to northern Europe during April and May 1976. Data were recorded in four separate geographical regions – namely, off the southern coast of Denmark, over southern England, over northern Germany, and over central Netherlands. The daytime flight conditions for the eight flights reported herein ranged from clear with haze to fully overcast.

The airborne radiometric instrumentation, developed at the Visibility Laboratory and mounted in Air Force C-130A Aircraft No. 50022, consisted of a total scattering meter (or integrating nephelometer) for determining the total volume scattering coefficient, two sky scanning radiometers for measuring upper and lower hemisphere (sky and terrain) radiances, a dual irradiator for measuring alternately the downwelling and upwelling irradiances, an equilibrium radiance telephotometer, and a variable direction path function meter. The meteorological instrumentation included an absolute pressure transducer, a dewpoint hygrometer, and an AN/AMQ-17 aerograph for measuring ambient temperature and pressure.

A Visibility Laboratory ground-based data station equipped with a contrast reduction meter for determining earth-to-space beam transmittance was located near the flight track during the flights in Germany and The Netherlands. It was not utilized during the flights in Denmark and England.

---

\*The project title OPAQUE I has been assigned to this activity by the Air Force Geophysics Laboratory as a nickname for procedural identification only. It is not necessarily utilized or recognized by agencies or organizations outside of the participating USAF organizations and the Visibility Laboratory. The relationship between this activity and other similar activities conducted by the Visibility Laboratory is well-illustrated in AFCRL-75-0457, Duntley, *et al.* (1975b).

Each optical instrument was fitted with four optical filters causing it to measure at three narrow band wavelengths of the spectrum and in one broad pass band. The measurements were made using three narrow band filters at mean wavelengths of 478, 664, and 765 nanometers and a pseudo-photopic filter with a mean wavelength of 557 nanometers.

All primary data were recorded on magnetic tapes which were returned to the Visibility Laboratory for processing at the computer facilities of the University of California, San Diego.

## TABLE OF CONTENTS

SUMMARY . . . . .	v
LIST OF ILLUSTRATIONS. . . . .	ix
RELATED CONTRACTS AND PUBLICATIONS . . . . .	xi
GLOSSARY AND NOTATION. . . . .	xiii
1. INTRODUCTION. . . . .	1-1
2. THEORY AND COMPUTATIONAL PROCEDURES . . . . .	2-1
3. INSTRUMENTATION . . . . .	3-1
3.1 Radiometric Systems . . . . .	3-1
3.2 Meteorological Systems . . . . .	3-4
3.3 Control and Communication Systems . . . . .	3-5
3.4 Photographic Systems . . . . .	3-5
3.5 Radiometric Calibration Procedures. . . . .	3-5
3.6 Standard Response Characteristics for Broad Band Sensors. . . . .	3-7
4. DATA COLLECTION METHODS . . . . .	4-1
4.1 Airborne System . . . . .	4-1
4.2 Ground-Bases System . . . . .	4-4
5. DATA PROCESSING . . . . .	5-1
5.1 Airborne Data . . . . .	5-1
5.2 Ground-Based Data . . . . .	5-1
5.3 Calibration Data. . . . .	5-4
5.4 Data Tapes . . . . .	5-4
6. WEATHER SUMMARY . . . . .	6-1
6.1 Introduction and Graphics. . . . .	6-1
6.2 Synoptic Conditions . . . . .	6-9
6.3 Tabular Summary and Glossary. . . . .	6-10

7.	DATA PRESENTATION . . . . .	7-1
7.1	Airborne Data and Flight Summary . . . . .	7-1
7.2	Description of Airborne Data Tables and Graphs . . . . .	7-6
7.3	Presentation of Airborne Data . . . . .	7-9
8.	DATA INTERPRETATION AND EVALUATION . . . . .	8-1
8.1	Meteorological Data . . . . .	8-1
8.2	Airborne Radiometric Data . . . . .	8-5
8.3	Summary . . . . .	8-22
9.	ACKNOWLEDGEMENTS . . . . .	9-1
10.	REFERENCES . . . . .	10-1

## LIST OF ILLUSTRATIONS

Figure	Page
1-1 Typical OPAQUE I Flight Tracks . . . . .	1-2, 1-3, 1-4
1-2 Standard Spectral Responses – Project OPAQUE I. . . . .	1-5
2-1 Path Length Geometry for Steeply Inclined Paths of Sight . . . . .	2-3
3-1 C-130 Airborne Instrument System . . . . .	3-2
3-2 Ground-Based Instrument System . . . . .	3-2
3-3 Artist's Rendition of Modified Integrating Nephelometer . . . . .	3-3
3-4 Typical Absolute Calibration Form. . . . .	3-6
4-1 Typical Visibility Laboratory Flight Profile . . . . .	4-2
5-1 Atmospheric Visibility Program Data Processing Schedule . . . . .	5-2
5-2 Atmospheric Visibility Program Data Processing Schedule . . . . .	5-3
6-1 Synoptic Surface Charts of European Area During Project OPAQUE I . . . . .	6-3
6-2 Temperature Versus Altitude for Eight Project OPAQUE I Flights . . . . .	6-5
6-3 Relative Humidity Versus Altitude for Eight Project OPAQUE I Flights . . . . .	6-7
7-1 Typical Sky and Terrain Photographs for Flight C-372 and C-373. . . . .	7-4
7-2 Typical Sky and Terrain Photographs for Flight C-379 and C-381. . . . .	7-5
8-1 Temperature for OPAQUE I Flights 12 April to 26 May 1976 Compared to Temperature from U.S. Standard Atmosphere Supplements. . . . .	8-3
8-2 Comparison of the Photopic Scattering Coefficient and Relative Humidity Profiles as Measured During Flights C-376 and C-379 . . . . .	8-4
8-3 Proportional Volume Scattering Function Related to Equivalent Ground Level Total Volume Scattering Coefficient for the Photopic Barteneva Classes and for the Pseudo-Photopic Filter Mean Wavelength 557 Nanometers for Five Deployments . . . . .	8-7

8-4	Measured Proportional Volume Scattering Function and Equivalent Ground Level Total Volume Scattering Coefficient for Filter 4 Pseudo-Photopic Filter Mean Wavelength 557 Nanometers for OPAQUE I . . . . .	8-8
8-5	Total Volume Scattering Coefficient as a Function of Volume Scattering Function at 30 Degrees for OPAQUE I Filter 4 Pseudo-Photopic Mean Wavelength 557 Nanometers . . . . .	8-9
8-6	Corrected Proportional Volume Scattering Function and Corrected Equivalent Ground Level Total Volume Scattering Coefficient for Filter 4 Pseudo-Photopic OPAQUE I . . . . .	8-10
8-7	Proportional Volume Scattering Function Related to Equivalent Ground Level Total Volume Scattering Coefficient for Filter 2 Mean Wavelength 478 Nanometers for Four Deployments . . . . .	8-11
8-8	Total Volume Scattering Coefficient for Filter 4 Pseudo-Photopic for Eight OPAQUE I Flights . . . . .	8-14
8-9	Total Volume Scattering Coefficient for Filter 4 Pseudo-Photopic from Straight and Level Flight Elements as a Function of Relative Humidity . . . . .	8-17
8-10	Project OPAQUE I Low Altitude Downwelling Irradiance for Filter 4 Pseudo-Photopic Compared to Brown (1952) . . . . .	8-20

## RELATED CONTRACTS AND PUBLICATIONS

Related Contracts: None

### Publications:

Duntley, S. Q., R. W. Johnson, and J. I. Gordon, "Airborne Measurements of Optical Atmospheric Properties in Southern Germany," AFCRL-72-0255, SIO Ref. 72-64 (July 1972).

Duntley, S. Q., R. W. Johnson, and J. I. Gordon, "Airborne and Ground-Based Measurements of Optical Atmospheric Properties in Central New Mexico," AFCRL-72-0461, SIO Ref. 72-71 (September 1972).

Duntley, S. Q., R. W. Johnson, and J. I. Gordon, "Airborne Measurements of Optical Atmospheric Properties, Summary and Review," AFCRL-72-0593, SIO Ref. 72-82 (November 1972).

Duntley, S. Q., R. W. Johnson, and J. I. Gordon, "Airborne Measurements of Optical Atmospheric Properties in Southern Illinois," AFCRL-TR-73-0422, SIO Ref. 73-24 (July 1973).

Duntley, S. Q., R. W. Johnson, and J. I. Gordon, "Airborne and Ground-Based Measurements of Optical Atmospheric Properties in Southern Illinois," AFCRL-TR-74-0298, SIO Ref. 74-25 (June 1974).

Duntley, S. Q., R. W. Johnson, and J. I. Gordon, "Airborne Measurements of Optical Atmospheric Properties in Western Washington," AFCRL-TR-75-0414, SIO Ref. 75-24 (September 1975).

Duntley, S. Q., R. W. Johnson, and J. I. Gordon, "Airborne Measurements of Optical Atmospheric Properties, Summary and Review II," AFCRL-TR-75-0457, SIO Ref. 75-26 (September 1975).

Duntley, S. Q., R. W. Johnson, and J. I. Gordon, "Airborne Measurements of Optical Atmospheric Properties in Northern Germany," AFGL-TR-76-0188, SIO Ref. 76-17 (September 1976).

Gordon, J. I., J. L. Harris, Sr., and S. Q. Duntley, "Measuring Earth-to-Space Contrast Transmittance from Ground Stations," *Appl. Opt.* **12**, 1317 – 1324 (1973).

Gordon, J. I., C. F. Edgerton, and S. Q. Duntley, "Signal-Light Nomogram," *J. Opt. Soc. Am.* **65**, 111 – 118 (1975).

## GLOSSARY AND NOTATION

The notation used in reports and journal articles produced by the Visibility Laboratory staff follows, in general, the rules set forth in pages 499 and 500, Duntley *et al.* (1957). These rules are:

Each optical property is indicated by a basic (parent) symbol.

A presubscript may be used with the parent symbol as an identifier, e.g.,  $b$  indicates background while  $t$  denotes an object.

A postsubscript may be used to indicate the length of a path of sight, e.g.,  $r$  denotes an *apparent* property as measured at the end of a path of sight of length  $r$ , while  $o$  denotes an *inherent* property based on the hypothetical concept of a photometer located at zero distance from an object.

A postsuperscript\*, or a postsubscript\*, is employed as a mnemonic symbol signifying that the radiometric quantity has been generated by the scattering of ambient light reaching the path from all directions.

The parenthetical attachments to the parent symbol denote altitude and direction. The letter  $z$  indicates altitude in general;  $z_t$  is used to specify the altitude of an object. The direction of a path of sight is specified by the zenith angle  $\theta$  and the azimuth  $\phi$ . In the case of irradiances, the downwelling irradiance is designated by  $d$ , the upwelling by  $u$ .

The glossary for meteorological symbols is presented in Section 6.

$A(z)$	Albedo at altitude $z$ , defined by the equation $A(z) \equiv H(z,u)/H(z,d)$ .
AGL	Above ground level.
$e_v$	Saturated vapor pressure at dewpoint or frostpoint temperature.
$e_s$	Saturated vapor pressure at ambient temperature.

$H(z,d)$  Irradiance produced by downwelling flux as determined on a horizontal flat plate at altitude  $z$ . In this report  $d$  is used in place of the minus sign in the notation  $H(z,-)$  which appears in Duntley (1969). This property may be defined by the equation

$$H(z,d) \equiv \int_{2\pi} N(z,\theta',\phi') \cos\theta' d\Omega$$

$H(z,u)$  Irradiance produced by upwelling flux as determined on a horizontal flat plate at altitude  $z$ . Here  $u$  is substituted for the plus sign formerly used in the notation  $H(z,+)$ .

$L(z)$  Attenuation length at altitude  $z$ . This property is the reciprocal of the attenuation coefficient, that is,

$$L(z) \equiv \alpha(z)^{-1}$$

$\bar{L}(z)$  Equivalent attenuation length is defined as

$$\bar{L}(z) = \frac{-z}{\ln T_z(0,0)}$$

$N(z,\theta,\phi)$  Radiance as determined from altitude  $z$  in the direction specified by zenith angle  $\theta$  and azimuth  $\phi$ .

RH Relative humidity in percent  $RH = (e_v / e_s) 100$ .

$R/M(0)$  Universal gas constant.

$\overline{S_\lambda T_\lambda}$  Standardized relative spectral response of filter/cathode combination where  $S_\lambda$  is spectral sensitivity of the multiplier phototube cathode and  $T_\lambda$  is spectral transmittance of optical filter.

$s(z)$  Total volume scattering coefficient as determined at altitude  $z$ . This property may be defined by the equation

$$s(z) \equiv \int_{4\pi} \sigma(z,\beta) d\Omega$$

In the absence of atmospheric absorption, the total volume scattering coefficient is numerically equal to the attenuation coefficient.

$s_R(z)$  Total volume scattering coefficient for Rayleigh scattering at altitude  $z$ .

$T_r(z, \theta)$	Beam transmittance as determined at altitude $z$ for a path of sight of length $r$ at zenith angle $\theta$ . This property is independent of azimuth in atmospheres having horizontal uniformity. It is always the same for the designated path of sight or its reciprocal.
VV	Visibility as estimated by the meteorologists $VV \approx 3/s(z)$ .
$z$	Altitude, usually used as above ground level.
$z_t$	Altitude of an object.
$\alpha(z)$	Volume attenuation coefficient as determined at altitude $z$ . In the absence of atmospheric absorption, the attenuation coefficient is numerically equal to the volume scattering coefficient.
$\beta$	Symbol for scattering angle of flux from a light source. It is equal to the angle between the line from the source to the observer and the path of sight.
$\Delta$	Symbol to indicate incremental quantity and used with $r$ and $z$ to indicate small, discrete increments in path length $r$ and altitude $z$ .
$\delta\lambda$	Response area is defined as $\delta\lambda = \Sigma(\overline{S_\lambda T_\lambda}) \Delta\lambda$ .
$\theta$	Symbol for zenith angle. This symbol is usually used as one of two coordinates to specify the direction of a path of sight.
$\theta'$	Symbol for zenith angle usually used as one of two coordinates to specify the direction of a discrete portion of the sky.
$\lambda$	Symbol for wavelength.
$\bar{\lambda}$	Mean wavelength is defined as $\bar{\lambda} = \Sigma\lambda(\overline{S_\lambda T_\lambda}) \Delta\lambda / \delta\lambda$ .
$\rho(z)$	Density at altitude $z$ .
$\sigma$	Symbol for volume scattering function. Parenthetical symbols may be added; for example, $\beta$ may be used to designate the scattering angle from a source. In Gordon (1969) the parenthetical symbols are $z$ and $\beta$ for altitude and scattering angle.
$\sigma(z, \beta)/s(z)$	Proportional directional volume scattering function. This may be defined by the equation

$$\int_{4\pi} [\sigma(z, \beta)/s(z)] \equiv 1 .$$

$\phi$  Symbol for azimuth. The azimuth is the angle in the horizontal plane of the observer between a fixed point and the path of sight. The fixed point may be, for example, true

north, the bearing of the sun, or the bearing of the moon. This symbol is usually used as one of two coordinates to specify the direction of a path of sight.

$\phi'$  This symbol for azimuth is usually used as one of two coordinates to specify the direction of a discrete portion of the sky.

$\Omega$  Symbol for solid angle. For a hemisphere

$$\Omega = 2\pi \text{ steradians;}$$

for a sphere  $\Omega = 4\pi \text{ steradians.}$

# 1. INTRODUCTION

The field measurement program described in this report was organized under the project title OPAQUE I. It was conducted during April and May 1976 to obtain data for case studies of the spring-time atmospheric optical properties over northern Europe.

The OPAQUE I deployment was the first in a series that is planned to provide seasonal atmospheric optical data in several regions of northern Europe. These deployments are organized as a cooperative but independent effort associated with the NATO Research Study Group 8 of Panel IV, AC243 (Optical Atmospheric Quantities in Europe). The OPAQUE I deployment plan was specified in Air Force Geophysics Laboratory Operations Plan 1, OPAQUE I, dated 10 March 1976.

The Visibility Laboratory maintains a continuing program of improved techniques for predicting, by calculation from physical data, the probabilities that any object can be visually detected and recognized. The program is multifaceted in that it involves the development of techniques and expertise in several different technical areas, each related to the visual detection and recognition task. Several of the major areas are – for example, measurement and analysis of typical terrain characteristics and scene reflectances, studies in the restoration of atmospherically distorted images, measurement and analysis of the optical properties of the atmosphere, and studies into the perceptual capabilities of the human visual system and its electro-optical counterparts. The joint application of the techniques perfected in each of these specialty areas results in the determination of detection probabilities. Inclusion of allowances for *a priori* information and reasoning processes of the brain enable the probabilities of recognition, classification and identification of real-world objects to be predicted.

The instrumental and computational organization for implementing the continuing improvement of those techniques related to the documentation of optical atmospheric properties is documented in several preceding reports. The most recent of these reports is AFGL-TR-76-0188, Duntley, *et al.* (1976).

This report, Scientific Report No. 7, has been prepared under Contract No. F19628-76-C-0004. It contains measured profiles of atmospheric volume scattering coefficient and downwelling irradiances between ground level and altitudes up to 6 kilometers. Computed values for vertical atmospheric beam transmittance, and equivalent attenuation length are also presented for the same altitude interval. The measurements were made along the flight tracks illustrated in Figs. 1-1a, 1b, 1c, 1d, and 1e. Selected meteorological properties measured concurrently with the radiometric data are also included.

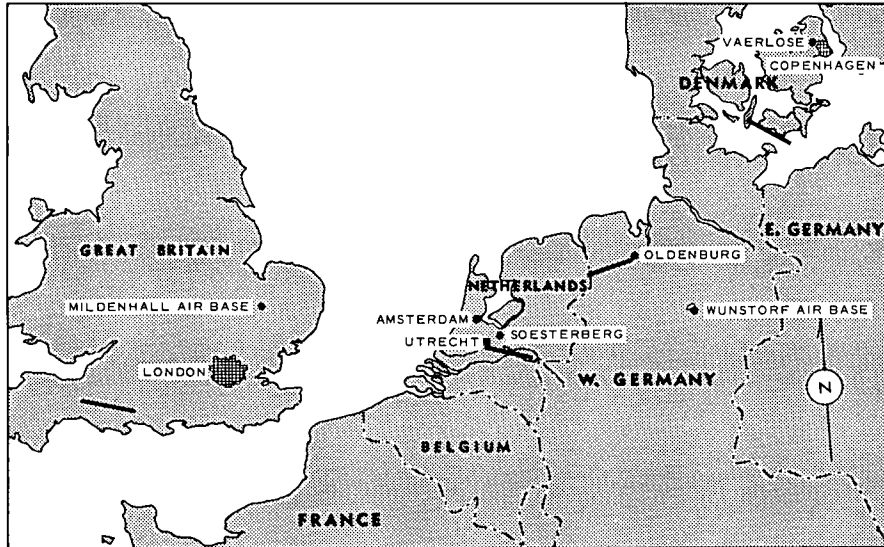

Fig. 1-1a. Typical OPAQUE I Flight Tracks.

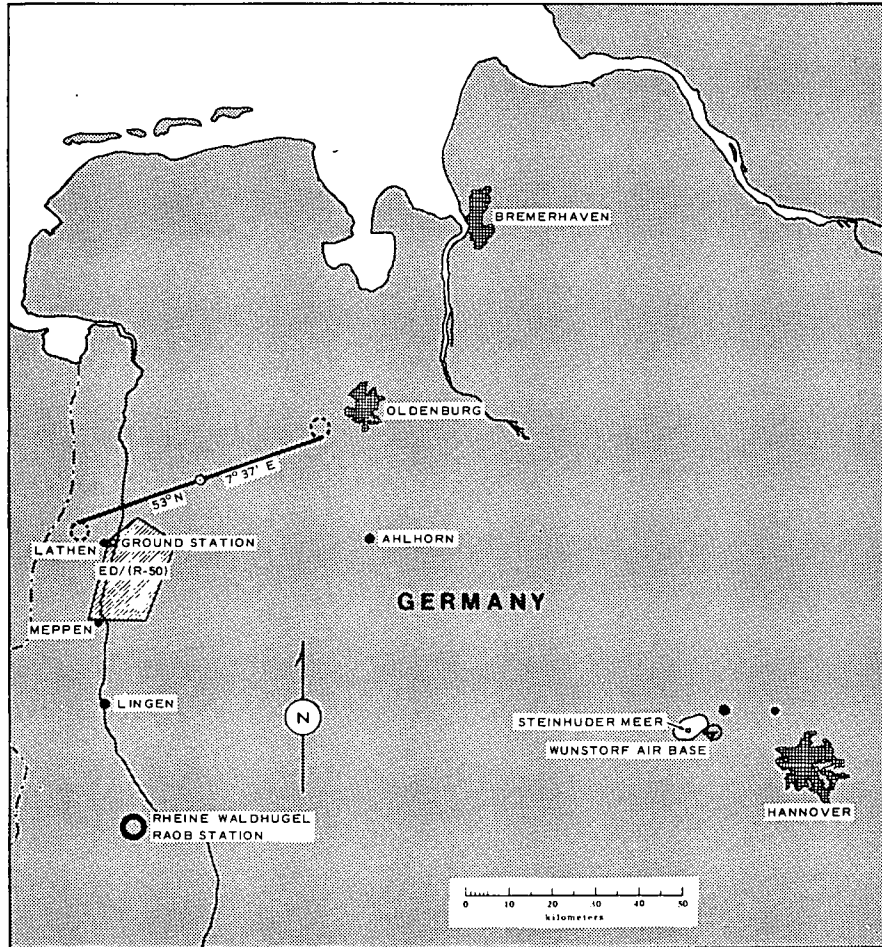

Fig. 1-1b. Typical OPAQUE I Data Sites, Detail Maps. Latitude and Longitude References are to Flight Track Center Point.

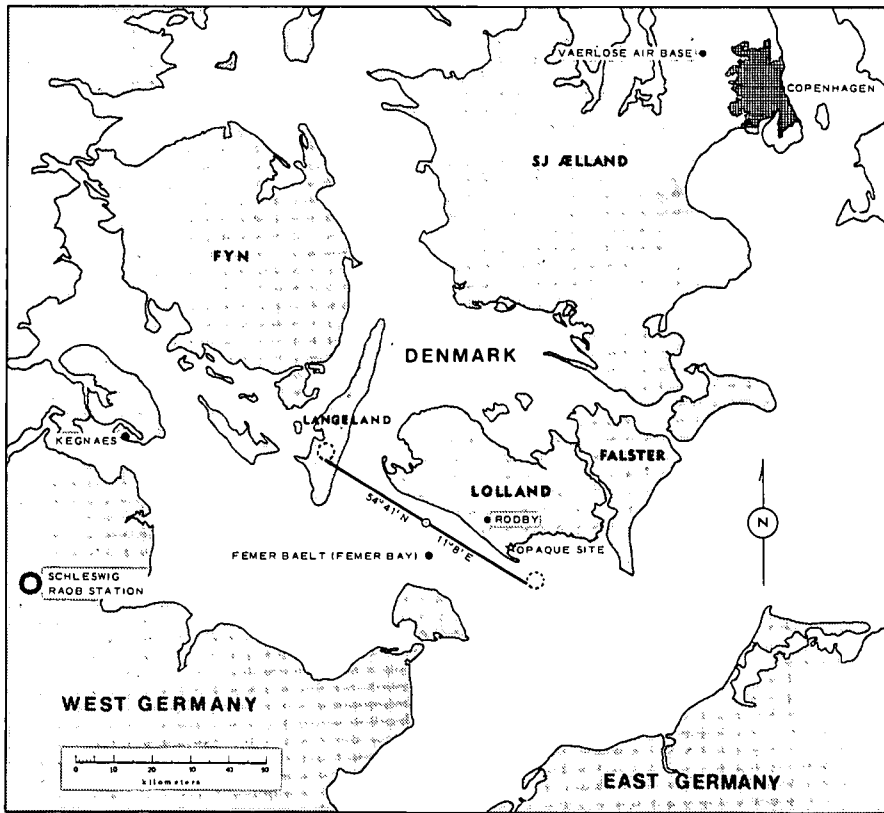

Fig. 1-1c. Typical OPAQUE I Data Sites, Detail Maps. Latitude and Longitude References are to Flight Track Center Point.

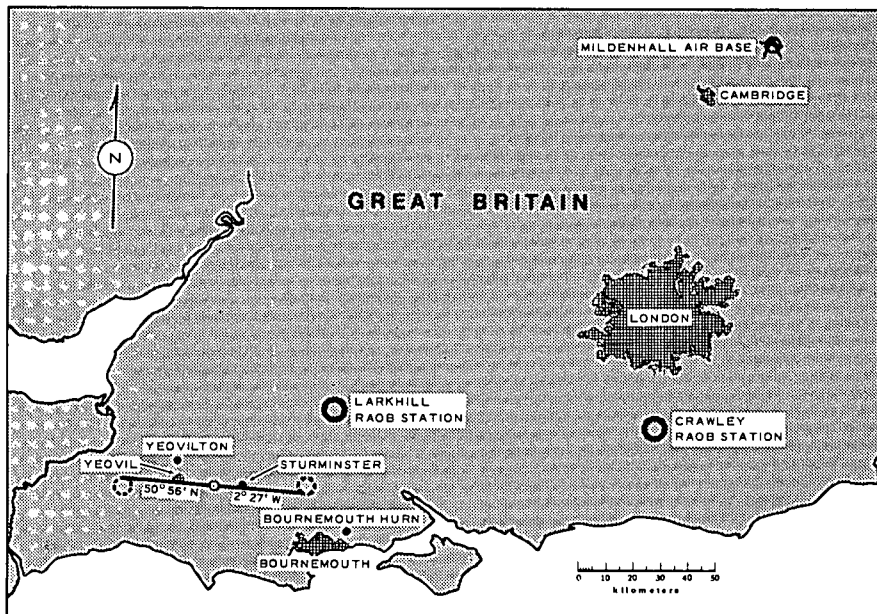

Fig. 1-1d. Typical OPAQUE I Data Sites, Detail Maps. Latitude and Longitude References are to Flight Track Center Point.

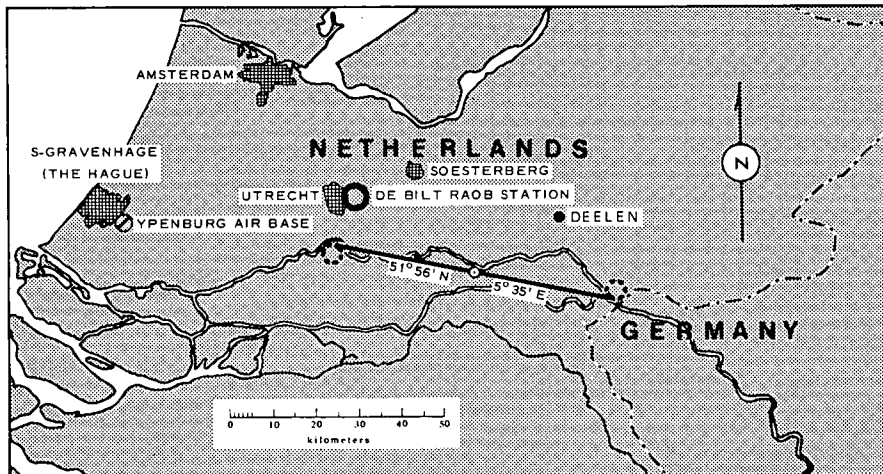

Fig. 1-1e. Typical OPAQUE I Data Sites, Detail Maps. Latitude and Longitude References are to Flight Track Center Point.

The methods used in the derivation and computation of the included optical properties are summarized in Section 2, and are similar where appropriate to those presented in AFGL-TR-76-0188, Duntley, *et al.* (1976). The most significant variation from earlier methods is in the technique used to correct the nephelometer measurements for internal stray light.

The instrumentation, developed at the Visibility Laboratory and installed in Air Force C-130A Aircraft No. 50022, is reported in detail in AFCRL-70-0137, Duntley, *et al.* (1970a), AFCRL-72-0593, Duntley, *et al.* (1972c), and AFCRL-TR-75-0457, Duntley, *et al.* (1975b). A brief review of the instrumentation as used during the OPAQUE I deployment is presented in Section 3.

The instrumentation used to generate the raw data upon which the reported properties are based consisted of an integrating nephelometer and a dual irradiator. Corroborative data were obtained using a ground-based contrast reduction meter to determine earth-to-space beam transmittances when weather permitted.

The radiometer spectral responses were standardized for the OPAQUE I deployment in the manner illustrated in Fig. 1-2.

Data collection methods were similar to those reported in AFCRL-TR-74-0298, Duntley, *et al.* (1974). The highest straight and level altitude was approximately 6000 meters above ground level (AGL). The basic features of these stylized daytime flight profiles are summarized in Section 4.

The computer techniques used for processing the data included in this report are summarized in Section 5. They are, in general, the same as the techniques reported in AFCRL-TR-75-0457, Duntley, *et al.* (1975b).

A general discussion of the weather patterns that predominated in the northern European area during the data collection interval is presented in Section 6. This section, in conjunction with the flight

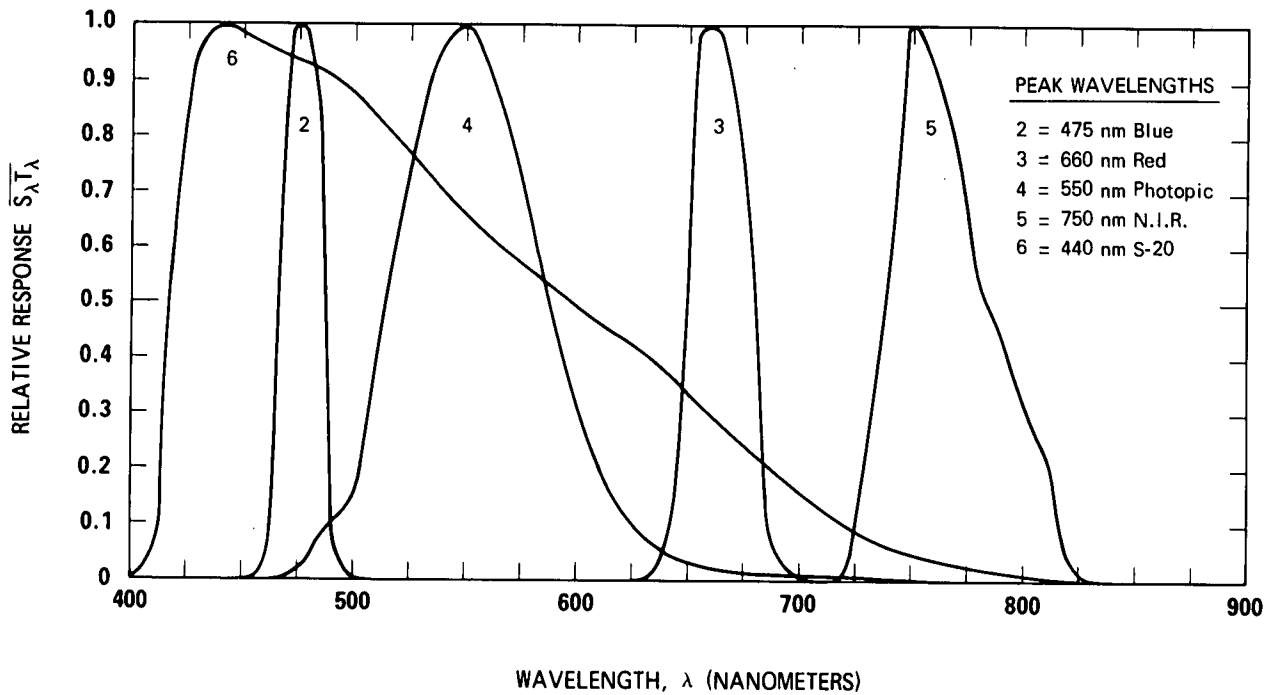

Fig. 1-2. Standard Spectral Responses – Project OPAQUE I.

track photographs shown in Section 7, is intended as an aid to the data user's generalized interpretation and evaluation. The inclusion of the graphical presentations is intended to further facilitate the user's rapid orientation with the overall weather situation.

The radiometric data representing eight separate flights are also presented in Section 7. The presentation format has been shortened from that used in AFCRL-TR-75-0414, Duntley, *et al.* (1975a) since only scattering coefficient and irradiance data are included.

Discussion related to the interpretation and evaluation of the data collected is found in Section 8.

## 2. THEORY AND COMPUTATIONS

The underlying theoretical concepts and the subsequent computational procedures upon which the Visibility Laboratory bases its determinations of contrast transmission through the troposphere are well documented in our preceding reports. The most recent of these, AFGL-TR-76-0188, "Airborne Measurements of Optical Atmospheric Properties in Northern Germany," Duntley, *et al.* (1976) is an appropriate reference and contains a substantial set of sample applications and references.

The format included in the following paragraphs has been extracted from the more complete description contained in the reference above. It is designed to support only the selected data appearing in Section 7 herein, and is not complete enough to develop contrast transmittance or any of the other more directional atmospheric optical properties normally associated with the reports in this series.

### TOTAL VOLUME SCATTERING COEFFICIENT

A direct measure of air clarity is the atmospheric attenuation coefficient  $\alpha(z)$ . The parenthetical modifier indicates the altitude  $z$ . The attenuation coefficient is the sum of the total volume scattering coefficient and the absorption coefficient. If there is no absorption, the attenuation coefficient is numerically equal to the total volume scattering coefficient  $s(z)$ .

The total volume scattering coefficient may be defined by the equation

$$s(z) \equiv \int_{4\pi} \sigma(z, \beta) d\Omega , \quad (2.1)$$

where  $\sigma(z, \beta)$  is the volume scattering function at altitude  $z$  and scattering angle  $\beta$ . The integrating nephelometer used to make the total volume scattering coefficient measurements performs the integral in Eq. 2.1 optically. It utilizes a parallel light beam and a cosine-law collector viewing the scattered flux. The instrument is similar in principle to one of four instruments for measuring total volume scattering coefficient described by Beuttell and Brewer (1949).

## BEAM TRANSMITTANCE

The beam transmittance  $T_r(z, \theta)$  at altitude  $z$ , zenith angle  $\theta$ , and over path length  $r$  is obtained directly from the total scattering coefficient  $s(z)$  by means of Eq. 2.2. (Refer also to Boileau (1964), p. 570.) When there is no significant atmospheric absorption in the passbands of the measurements, e.g., from smoke, dust, or smog, the attenuation coefficient  $\alpha(z)$  is equivalent to the total volume scattering coefficient  $s(z)$ . Therefore,

$$T_r(z, \theta) = \exp \left[ - \sum_{i=1}^n \alpha(z_i) \Delta r \right] = \exp \left[ - \sum_{i=1}^n s(z_i) \Delta r \right] , \quad (2.2)$$

where  $\Delta r$  is the incremental path length. The summations are made using the trapezoidal rule. The measured total volume scattering coefficient data are extrapolated to ground level when no ground-based measurements are available. The extrapolation assumes that the scattering particles are the same at all altitudes, but decrease or increase according to the density at each altitude  $\rho(z)$ :

$$s(0) = \frac{s(z) \rho(0)}{\rho(z)} . \quad (2.3)$$

Similarly, upward extrapolations are made to the highest reported altitude above ground level when the highest flight altitude is less. Extrapolation in this case is based on the scattering coefficient measured at the highest flight altitude. The densities used for the extrapolations are based upon the U. S. Standard Atmosphere (1962). The density at each altitude is obtained by truncated Chebyshev Expansion using the coefficients for the atmosphere between 0 and 80 kilometers [U. S. Standard Atmosphere Supplements (1966), p. 69].

All altitudes reported are between ground level and 6.3 kilometers maximum. For all paths of sight at zenith angles less than 85 degrees or greater than 95 degrees,  $\Delta r$  equals  $\Delta z \sec \theta$  for these altitudes. The  $\Delta r$  is always nonnegative since  $\Delta z$  is defined as  $z_1 - z_2$  (the subscripts increase with the flux direction). See Fig. 2-1. The  $|\Delta z|$  used is 30 meters (98.4 feet). For zenith angles greater than 95 degrees, the beam transmittance can also be expressed as a function of the vertical beam transmittance  $T_r(z, 180^\circ)$  as follows:

$$T_r(z, \theta) = T_r(z, 180^\circ)^{|\sec \theta|} . \quad (2.4)$$

For upward paths of sight for zenith angles less than 85 degrees, the beam transmittance can similarly be expressed as a function of the vertical upward transmittance  $T_r(z, 0^\circ)$ . The computations described above are useful in determining  $T_r$  for a variety of zenith angles, however the data included in Section 7 of this summary report are restricted to the vertical path only.

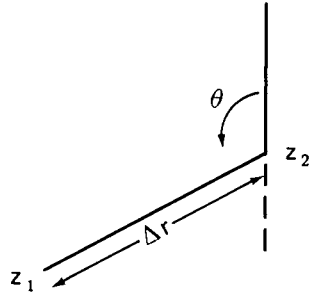

Fig. 2-1. Path Length Geometry for Steeply Inclined Paths of Sight.

## ATTENUATION LENGTH

The attenuation length  $L(z)$  is defined as the reciprocal of the atmospheric attenuation coefficient  $\alpha(z)$ . Therefore, when there is no significant absorption, it is also equivalent to the reciprocal of the atmospheric total volume scattering coefficient:

$$L \equiv \frac{1}{\alpha(z)} = \frac{1}{s(z)} \quad (2.5)$$

The equivalent attenuation length  $\bar{L}(z)$  is a pseudo-attenuation length which, when combined with its altitude  $z$ , can be used directly in the equation [Boileau (1964), Eq. 6.1]

$$T_r(z, \theta) = \exp[-z/\bar{L}(z)] |\sec \theta| \quad (2.6)$$

where  $\theta > 95^\circ$  and path length  $r$  is between ground level and altitude  $z$ . Combining Eq. 2.6 and Eq. 2.2 and appropriately rearranging, the following expression may be obtained for effective attenuation length,

$$\bar{L}(z_n) = \frac{z_n}{\sum_{i=1}^n s(z_i) \Delta z} \quad (2.7)$$

For  $\theta < 85^\circ$ , the  $\bar{L}(z)$  values should be interpreted as applying to the object altitude with the sensor at ground level.

## EARTH CURVATURE AND REFRACTION

For the paths of sight at zenith angles from 90 to 95 degrees, the  $\Delta r$  for  $|\Delta z| = 30$  meters (98.4 feet) is significantly longer at ground level than at 6 kilometers due to the curvature of the earth. Also for upward-looking paths of sight from 85 to 90 degrees, the  $\Delta r$  for  $\Delta z = 30$  meters (98.4 feet) is significantly shorter at 6 kilometers than at ground level due to the curvature of the earth. Thus for paths of sight between 85 and 95 degrees in zenith angle, Eqs. 2.4 and 2.6 should not be used. Instead, Eq. 2.2 should be used with the appropriate  $\Delta r$  values.

## DOWNWELLING IRRADIANCE

The downwelling irradiance on a horizontal flat plate may be defined by the equation

$$H(z,d) \equiv \int_{2\pi} N(z,\theta',\phi') \cos\theta' d\Omega \quad , \quad (2.8)$$

where  $N(z,\theta',\phi')$  is the radiance at altitude  $z$  in the direction of zenith angle  $\theta'$  and azimuth  $\phi'$ . The downwelling irradiance was measured by a dual irradiator which performed the integration in Eq. 2.8 optically with a cosine-law collector. During the ascents and descents of the aircraft when total volume scattering coefficient was being measured, the dual irradiator was simultaneously measuring downwelling irradiance. The downwelling irradiance provides a quantitative measure of the ambient flux levels during the flight.

## UPWELLING IRRADIANCE

The upwelling irradiance on a horizontal flat plate is designated by  $H(z,u)$ . The dual irradiator alternately measured upwelling and downwelling irradiance at low, intermediate, and high altitude during intervals of straight and level flight which preceded or followed the ascents and descents.

## ALBEDO

Albedo  $A(z)$  is defined as

$$A(z) \equiv H(z,u)/H(z,d) \quad . \quad (2.9)$$

Albedos were determined from the upwelling and downwelling irradiance measurements made with the dual irradiator during the straight and level flight intervals for each flight.

## RELATIVE HUMIDITY

The relative humidity is computed using the measured ambient temperature, the measured dewpoint

temperature and their associated partial pressures of water vapor. The relative humidity in percent is computed from the equation

$$RH = (e_v/e_s) 100 \quad , \quad (2.10)$$

where  $e_v$  is the saturated vapor pressure at dewpoint or frostpoint temperature, and  $e_s$  is the saturated vapor pressure at ambient temperature. The saturated vapor pressures over water and over ice are obtained from the Smithsonian Meteorological Tables (1951).

## 3. INSTRUMENTATION

The scientific instrumentation utilized for the Project OPAQUE I task was basically the same as that reported in AFCRL-54-75-0457, Duntley, *et al.* (1975b) and AFGL-TR-76-0188, Duntley, *et al.* (1976). Consequently, the descriptions contained herein have been edited to include only those systems directly related to the scattering coefficient and irradiance data. The total instrumentation package utilized during the Project OPAQUE I deployment is illustrated in Fig. 3-1 and 3-2.

### 3.1 RADIOMETRIC SYSTEMS

Of the seven different types of radiometric collector assemblies mounted on board the aircraft, only two have their descriptive summaries included in this report, the integrating nephelometer and the dual irradiator.

#### INTEGRATING NEPHELOMETER (NEPH) ASSEMBLY

In order to measure and evaluate the total volume scattering coefficient for typical real aerosols, the Visibility Laboratory has devised and built an instrument referred to as an integrating nephelometer. The basic structure of the device consists of the subassembly illustrated in Fig. 3-3 and an enclosing light tight box. In the airborne version, ram air driven by the aircraft's forward velocity is routed through the box via four one-inch diameter inlet tubes and four one and one-half-inch diameter exhaust tubes.

In its operational mode, the integrating nephelometer measures the radiant flux scattered by the transient aerosol as it passes through the geometrically well defined flux beam from a high intensity projector. The scattered flux is sequentially collected through one of three different optical channels: two telescopes, each having 2-degree circular fields of view oriented to collect the flux scattered in the  $\beta=30^\circ$  and  $\beta=150^\circ$  directions, and one  $2\pi$  irradiator assembly oriented to collect the flux scattered in all scattering angles between  $\beta=5^\circ$  and  $\beta=170^\circ$ . From these measurements plus the measurement of a well defined calibration flux level, the directional scattering functions  $\sigma(30)$  and  $\sigma(150)$  and the total volume scattering coefficient  $s$  may be derived.

In its simplest form, the equation which is used to compute the total volume scattering coefficient is

$$s = \frac{s_H K}{r_H F} \quad (3.1)$$

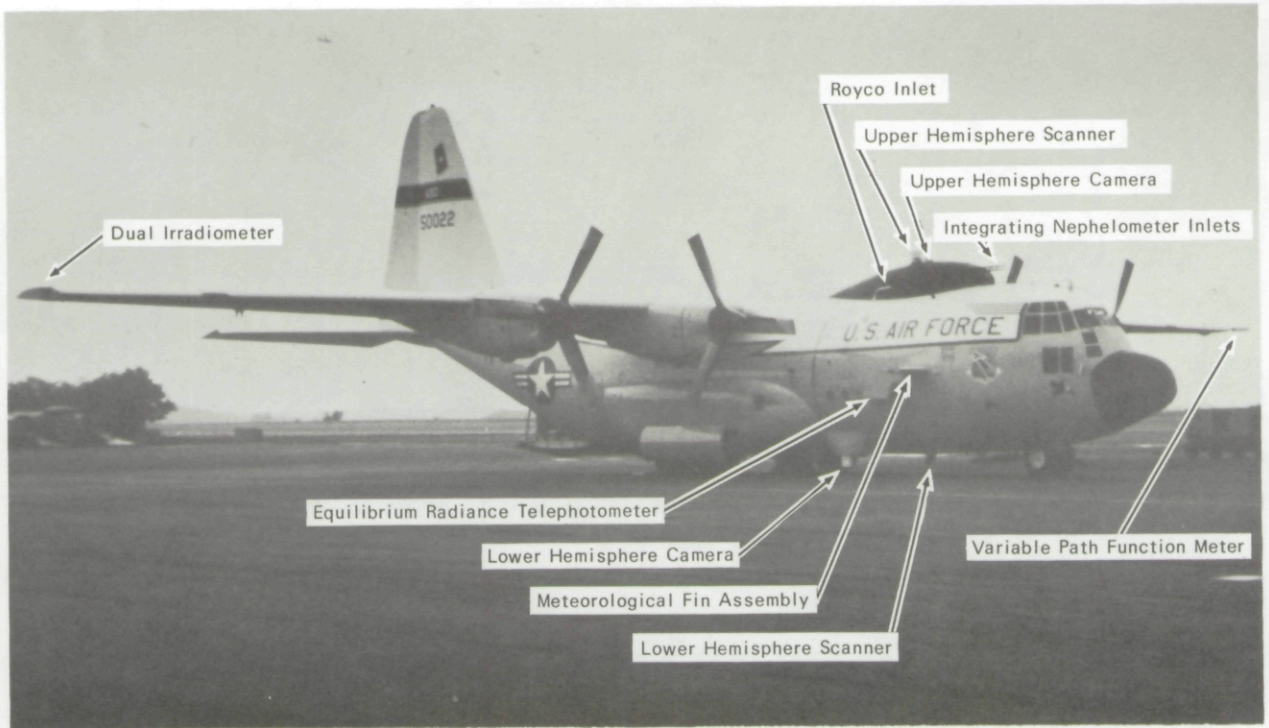

Fig. 3-1. C-130 Airborne Instrument System.



Fig. 3-2. Ground-Based Instrument System.

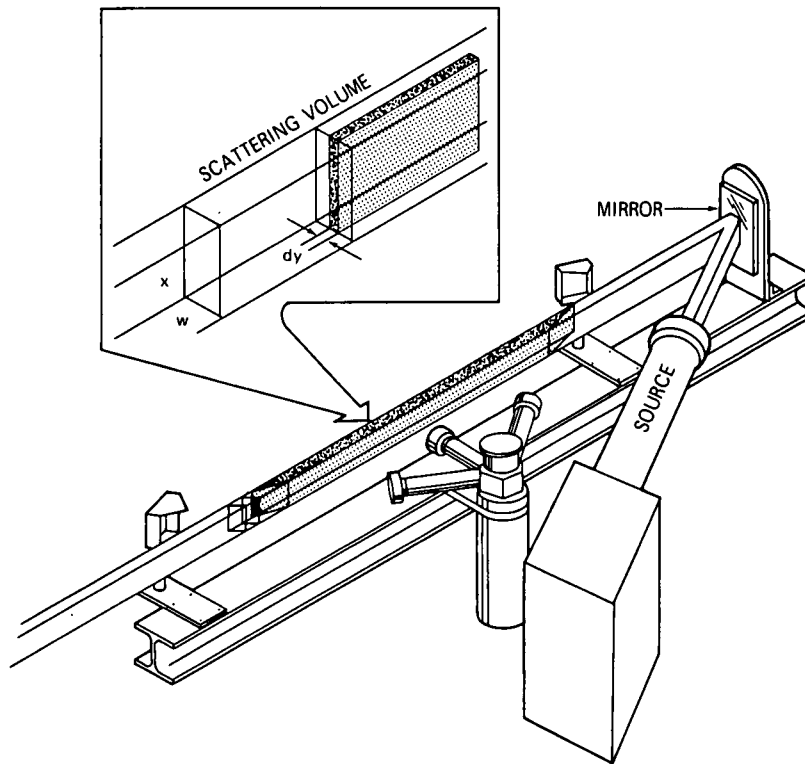

Fig. 3-3. Artist's Rendition of Modified Integrating Nephelometer.

where

$H_s$  is the flux scattered from the beam and collected by the instrument's irradiometer channel while in the operational mode, and

$H_c$  is the flux reflected from a diffusely reflecting calibration plaque and collected by the irradiometer channel while the instrument is in the calibration mode.

The constants  $K$  and  $F$  are rather extensive integral expressions which relate the geometry of the scattering volume with respect to the irradiometer cap location, the irradiance distribution in the flux beam, the transmittance and reflectance characteristics of the collector cap and calibration plaque, and the most probable shape of the scattering function associated with the sample aerosol.

The ratio  $K/F$  for the airborne integrating nephelometer has been computed using the Rayleigh volume scattering function and a set of ten additional volume scattering functions representative of a broad range of real atmospheres as determined from Barteneva (1960). Using the in-flight measured values of  $\sigma(30)$  and  $\sigma(150)$  from the nephelometer, the most probable scattering function for the sample aerosol can be selected, and the appropriate  $K/F$  factor applied. It is the application of this procedure for determining the most probable scattering function from measured data, and applying this supplementary knowledge of the character of the sample aerosol as a correction to the measurement for total scattering coefficient which makes this instrument unique and potentially superior for research applications.

The mechanical and optical configurations of the integrating nephelometer utilized on the OPAQUE I deployment have changed from those reported in AFCRL-70-0137, Duntley, *et al.* (1970a). The basic change is that the projector beam has been optically folded by inserting a plane mirror into the beam between the projector and the beginning of the scattering volume. This optical folding has enabled the shortening of the mechanical frame and housing such that the entire assembly can be enclosed in an aerodynamic shroud. The modified nephelometer is illustrated in AFCRL-TR-75-0457, Duntley, *et al.* (1975b). The operating characteristics of the revised nephelometer were discovered to suffer from abnormally high stray light problems during the post deployment analysis of the OPAQUE I data, and further modification was accomplished subsequent to its return to the Laboratory. No further evidence of stray light contamination has been observed.

The modified nephelometer is enclosed in the modified radome shown on top of the aircraft in Fig. 3-1, and an artist's rendition of the modified arrangement of the internal subassemblies is illustrated in Fig. 3-3.

#### DUAL IRRADIOMETER (DI) ASSEMBLY

The dual irradiometer assembly is a two-channel irradiometer. It has two optical input channels but only one optical output. A rotating prism subassembly allows the system operator to select either input channel for optical coupling with the output channel, while simultaneously occulting the other. The resultant time-sharing of a single detector assembly yields a device optimized for ratio type measurements.

The flat plate diffuse collector surfaces used in this assembly are mechanically corrected to yield cosine collection characteristics between 0 and 90 degrees which are within  $\pm 2$  percent of true cosine for all angles of incidence between 0 and 90 degrees.

The dual irradiometer assembly is mounted on the aircraft wingtip so that the flat plate collectors are horizontal during normal straight and level (ST&LV) flight elements. In this configuration the upper channel receives radiant flux from the entire hemisphere above the aircraft, and the lower channel receives radiant flux from the entire hemisphere below the aircraft. These measurements of downwelling and upwelling irradiance can be used both in the calculation of directional terrain reflectances and in intersystem data validation checks.

### 3.2 METEOROLOGICAL SYSTEMS

All of the meteorological systems utilized in this project were purchased items; the operating characteristics of each are available in the appropriate manufacturer's brochures. For use in Project OPAQUE I, the meteorological systems were unchanged from the configurations reported in AFCRL-72-0593, Duntley, *et al.* (1972c).

The airborne meteorological package consisted of one Royco Model 220 particle counter, one Cambridge Model 137-C3 aircraft hygrometer system, one AN/AMQ-17 aerograph set, and two Bourns aneroid pressure transducers.

Since all of the meteorological systems were described in AFCRL-72-0255, Duntley, *et al.* (1972a) and AFCRL-72-0593, Duntley, *et al.* (1972c), no further discussion is included in this report.

### 3.3 CONTROL AND COMMUNICATION SYSTEMS

The basic control panels, consoles, and other support facilities associated with the airborne instrument system are described fully in AFCRL-70-0137, Duntley, *et al.* (1970a) and the updated configurations are reported in AFCRL-72-0593, Duntley, *et al.* (1972c).

### 3.4 PHOTOGRAPHIC SYSTEMS

Photographic documentation of the test environment performed simultaneously with the radiometric and meteorological measurements has always been a highly desirable adjunct to any field activity. For Project OPAQUE I, this photographic capability was accomplished by the Visibility Laboratory through the use of two camera systems.

#### AIRBORNE AUTOMAX G-1 CAMERA SYSTEM

Two 35-millimeter Automax G-1 cameras, modified to accept Traid 735 Periphoto (180-degree) lenses, were mounted on the project aircraft (Fig. 3-1). One camera was oriented to photograph the  $2\pi$  upper hemisphere and the other covered the  $2\pi$  lower hemisphere. Either or both cameras may be run in either cine or single-frame modes at the discretion of the operator.

The photographs from these cameras are used only as general background for the interpretation of the radiometric measurements. Thus, no special controls are placed upon the film or its processing. For this general-purpose application, the cameras are normally loaded with Kodak Ektacolor Professional S, No. 5026 film. Typical photographs from this system are used as illustrations in Section 7 of this report and were shot with a fixed f6.3 aperture in the single-frame mode.

#### GROUND-BASED SOLIGOR SYSTEM

The ground-site documentation photographs have historically been limited to 35-millimeter color snapshots, taken on a casual basis during lulls in the experimental sequences. For Project OPAQUE I this procedure was supplemented with a scheduled routine of site photographs using a Soligor Conversion Fisheye lens. This lens possesses almost universal adaptability to a wide variety of cameras and prime lenses. During Project OPAQUE I it was used on a Yashica, Lynx 1000.

### 3.5 RADIOMETRIC CALIBRATION PROCEDURES

All the radiometers used in this project are calibrated in essentially the same manner. In each case, the system is calibrated first by determining its relative flux versus high voltage characteristics over the anticipated operating span and second by establishing known absolute flux levels on this voltage curve. The entire calibration procedure is conducted by using standard photometric practices, a 3-meter optical bench, and incandescent standards of luminous intensity traceable to the National Bureau of Standards.

A detailed discussion of these calibration procedures is contained in AFCRL-70-0137, Duntley, *et al.* (1970a), AFGL-TR-76-0188, Duntley, *et al.* (1976), and most of the intervening reports in this series. The discussion therefore will not be repeated herein.

A typical data sheet for the absolute calibration of a Project OPAQUE I radiometer is shown in Fig. 3-4. Five different levels of input radiance are used in the determination of the calibration constant for the system. The calibration constant is referred to as the zero scale value and is labeled ZSV on the calibration forms.

### CALIBRATION CORRECTION FACTORS

Several calibration correction factors are used with the calibration data illustrated in Fig. 3-4 to generate the calibration constants listed in Table 3-1. In general, the factors are used at will to convert radiometric units into photometric units and reconvert them, and to adjust the value of measurements taken with an instrument having a nearly standard spectral response to the value that would have been obtained using the exact standard spectral response specified in Section 3.6.

These correction factors are discussed at length in AFCRL-70-0137 and AFCRL-72-0461, Duntley, *et al.* (1970a and 1972b). Thus, they are not discussed further at this time.

ABSOLUTE CALIBRATION FOR  
(30) NBP-1 SIGMA ( 9846 K5) ( IRRADIOMETER) TAKEN ON 3/12/76 (PREOPQ01) DEPLOYMENT  
FILTER NO. 4 (XENON 5500 DEGREES KELVIN)

SPAN ID	D1 CM	TOTAL DIST. CM	TOTAL DIST. SQ. CM.SQ.	CALC. TGT. B ON E *	DETEC. RAW OUTPUT	LOG OF (K0/K)	RAW ZSV	PERCENT DIFF OF RAW AVG	AVG RAW ZSV	F1 LUM. TO RAD. WATTS/LUM.	F2 COLOR MATCH	CORRECTED ZSV
1	4L	116.300	1.353E 04	8.232E-05	512	.733	4.452E-04	-2.8	4.330E-04	1.050E-03	1.00/E UV	4.278E-07
2	7F	146.300	2.140E 04	5.202E-05	477	.925	4.382E-04	-1.2				
3	12I	196.300	3.853E 04	2.890E-05	430	1.171	4.286E-04	1.0				
4	20L	276.300	7.634E 04	1.459E-05	369	1.463	4.239E-04	2.1				
5	30I	376.300	1.416E 05	7.864E-06	308	1.743	4.135E-04	-1.6				
4	20L	276.300	7.634E 04	1.459E-05	369	1.463	4.239E-04	2.1				
3	12I	196.300	3.853E 04	2.890E-05	429	1.176	4.333E-04	-1.1				
2	7F	146.300	2.140E 04	5.202E-05	477	.925	4.382E-04	-1.2				
1	4L	116.300	1.353E 04	8.232E-05	514	.720	4.324E-04	.1				

LINEARITY MAXIMUM = ( .631) APPLIED CUTOFF = ( -.955)  
LINEARITY CALIB. END = ( -.955) FULL DARK = ( -.998) CUTOFF = ( -.955)  
\* CALCULATED ILLUMINANCE IN LUMENS/SQ. CM.

RAW ZSV STD = ( 6.6797E-06) FRACT. STD = ( 1.54) PERCENT ZSV IN WATTS/SQ. CM. IS 4.278E-07  
WITH UNIT CONVERSION FACTOR OF ( 127300.00000), TO CHANGE UNITS FROM (W/ SQ. CM) TO (W/ SQ. M) THE NEW ZSV IN WATTS(SQ. M MICRO M. IS 5.0269E-02

THIS FILTER IS PSEUDO-PHOTOPIC. TO CONVERT TO TRUE PHOTOPIC STANDARD (SEE TECHNICAL MEMORANDUM AV71-000T)  
FOR DAYLIGHT DATA MULTIPLY BY 72.00RLUMEN-UM / WATT. PHOTOPIC ZSV IS 4.19591E 00 LUMEN/ SQ M.  
FOR NIGHT TIME LIGHTING MULTIPLY BY 68.34RLUMEN-UM / WATT. PHOTOPIC ZSV IS 3.98262E 00 LUMEN/ SQ M.  
FOR NEPHELOMETER ONLY MULTIPLY BY 72.220LUMEN-UM / WATT. PHOTOPIC ZSV IS 4.20873E 00 LUMEN/ SQ M.

MV FLUCTUATION DATA DURING EACH CALIB MEASUREMENT			CALIBRATION LAMP IDENTIFICATION		CALIBRATION TARGET DATA	
SPAN ID	STD. DEV. IN MV	FRACT STD DEV IN PERCENT	SERIAL NUMBER =	LAMP INTENSITY =	DISTRIBUTION TEMPERATURE =	MONITOR CURRENT CHANNEL =
1	0	0	VL40201	22.27	2854	4
2	0	0				
3	8.851E-01	2.060E-01				
4	0	0				
5	0	0				
4	4.031E-01	1.312E-01				
3	0	0				
2	4.787E-01	1.117E-01				
1	0	0				
1	4.472E-01	8.696E-02				

REFLECTANCE OF PATH ATTENUATOR(PERCENT) = 5.0  
REFLECTANCE OF CALIBRATION TARGET(PERCENT) = 100.0  
DTOTAL = LAMP DISTANCE = D1 + D2. D2(CM) = 70.3  
PHOTOMETER DATA CHANNEL = 1

Fig. 3-4. Typical Absolute Calibration Form.

**Table 3.1**

**Project OPAQUE 1**

Radiometer Calibration Constants (ZSV) and Related Fractional Standard Deviations ( $\delta$ ) For Daylight Flights

Radiometer Identification		Calib Mode	Calib Units	Filter 2		Filter 4		Filter 3		Filter 5		Average % for System
System	MPT SN			ZSV	$\delta$ %	ZSV	$\delta$ %	ZSV	$\delta$ %	ZSV	$\delta$ %	
NEPH1 $\Sigma$	9846	Out	w / m <sup>2</sup> $\mu$ m	1.67E-01	1	5.83E-02	2	2.46E-01	1	4.24E-01	2	2
NEPH1 $\beta$ 30	9846	Out	w / $\Omega$ m <sup>2</sup> $\mu$ m	1.47E-01	1	6.17E-02	1	2.82E-01	1	7.66E-01	3	2
DI	14531	In	w / m <sup>2</sup> $\mu$ m	$\mu$ .19E+04	1	1.48E+04	1	5.90E+04	1	3.60E+05	2	1

**3.6 STANDARD RESPONSE CHARACTERISTICS FOR BROAD BAND SENSORS**

All the radiometric instruments both ground-based and airborne used by the atmospheric visibility branch are equipped with automatic filter changing assemblies. Thus, any one of five different spectral filters can be interposed into each instrument's optical path. The combination of the sensor sensitivity  $S_\lambda$  and the filter transmittance  $T_\lambda$  is the resultant sensitivity of the filtered phototube  $S_\lambda T_\lambda$ . The standard responses which each optical system attempts to duplicate are indicated as  $\overline{S_\lambda T_\lambda}$ , and are illustrated in Table 3.3. No system has true photopic response, Filter Code 9, but this ideal response is included for comparative purposes only.

A summary of the response characteristics of the standards for Project OPAQUE I is presented in Table 3.2. The first four columns give filter code, peak wavelength, mean wavelength, and response area, terms which are fully defined in preceding reports such as AFGL-TR-76-0188, Duntley, *et al.* (1976). The values for inherent solar properties are in columns 5, 6, and 7, and the Rayleigh limits are in columns 8, 9, and 10. The table was produced by Program RAYLIMIT.

**Table 3.2**  
Spectral Characteristics Summary for Project OPAQUE I

Spectral Characteristics for Project OPAQUE I				Inherent Sun Properties (Johnson)			Rayleigh Atmosphere Properties (15°C)		
Filter Code No.	Peak Wavelength (nm)	Mean Wavelength (nm)	Response Area (nm)	Irradiance ( $W/m^2\mu m$ )	Radiance ( $W/\Omega m^2\mu m$ )		Attenuation Length (m)	Total Scattering Coefficient (Per m)	Vertical Beam Transmittance
					Average	Center			
2	475	478	19.9	2.14E+03	3.13E+07	4.07E+07	4.84E+04	2.07E-05	0.839
3	660	664	30.2	1.57E+03	2.30E+07	2.75E+07	1.86E+05	5.41E-06	0.955
4	550	557	78.5	1.90E+03	2.78E+07	3.47E+07	8.93E+04	1.15E-05	0.907
5	750	765	50.4	1.23E+03	1.80E+07	2.10E+07	3.28E+05	3.08E-06	0.974
6	440	532	183.5	1.91E+03	2.80E+07	3.55E+07	7.22E+04	1.64E-05	0.867
9	555	560	106.9	1.89E+03	2.77E+07	3.45E+07	9.22E+04	1.15E-05	0.907

**Table 3.3**

**Relative Spectral Response of Standards for Project OPAQUE I**

Filter Identification and Mean Wavelength							Filter Identification and Mean Wavelength						
Wave-length (nm)	No. 2 Blue 478nm	No. 3 Red 664nm	No. 4 Pseudo- Photopic 557nm	No. 5 NIR 765nm	No. 6 S-20 532nm	No. 9 True Photopic 560nm	Wave-length (nm)	No. 2 Blue 478nm	No. 3 Red 664nm	No. 4 Pseudo- Photopic 557nm	No. 5 NIR 765nm	No. 6 S-20 532nm	No. 9 True Photopic 560nm
400	0	0	0	0	0	0.0004	615	0	0	0.1680	0	0.4500	0.4412
405	0	0	0	0	0.0129	0.0006	620	0	0	0.1300	0	0.4390	0.3810
410	0	0	0	0	0.0258	0.0012	625	0	0	0.1055	0	0.4260	0.3210
415	0	0	0	0	0.2969	0.0022	630	0	0	0.0810	0	0.4130	0.2650
420	0	0	0	0	0.5680	0.0040	635	0	0.0020	0.0657	0	0.3935	0.2170
425	0	0	0	0	0.7605	0.0073	640	0	0.0486	0.0504	0	0.3740	0.1750
430	0	0	0	0	0.9530	0.0116	645	0	0.1798	0.0411	0	0.3545	0.1382
435	0	0	0	0	0.9765	0.0168	650	0	0.5531	0.0318	0	0.3350	0.1070
440	0	0	0	0	1.0000	0.0230	655	0	0.9948	0.0268	0	0.3190	0.0816
445	0	0	0	0	0.9920	0.0298	660	0	1.0000	0.0218	0	0.3030	0.0610
450	0	0	0	0	0.9840	0.0380	665	0	0.9421	0.0188	0	0.2845	0.0446
455	0	0	0	0	0.9720	0.0480	670	0	0.8625	0.0157	0	0.2660	0.0320
460	0.0070	0	0	0	0.9600	0.0600	675	0	0.7482	0.0139	0	0.2480	0.0232
465	0.1487	0	0	0	0.9510	0.0739	680	0	0.4774	0.0120	0	0.2300	0.0170
470	0.8481	0	0	0	0.9420	0.0910	685	0	0.1585	0.0105	0	0.2105	0.0119
475	1.0000	0	0.0172	0	0.9355	0.1126	690	0	0.0495	0.0090	0	0.1910	0.0082
480	0.9329	0	0.0343	0	0.9290	0.1390	695	0	0.0166	0.0080	0	0.1755	0.0057
485	0.8304	0	0.0677	0	0.9175	0.1693	700	0	0	0.0070	0	0.1600	0.0041
490	0.1790	0	0.1010	0	0.9060	0.2080	705	0	0	0.0061	0	0.1445	0.0029
495	0.0292	0	0.1185	0	0.8920	0.2586	710	0	0	0.0053	0	0.1290	0.0021
500	0	0	0.1360	0	0.8780	0.3230	715	0	0	0.0048	0	0.1170	0.0015
505	0	0	0.2635	0	0.8560	0.4073	720	0	0	0.0042	0	0.1050	0.0010
510	0	0	0.3910	0	0.8340	0.5030	725	0	0	0.0038	0.1005	0.0938	0.0007
515	0	0	0.5085	0	0.8135	0.6082	730	0	0	0.0033	0.2010	0.0826	0.0005
520	0	0	0.6260	0	0.7930	0.7100	735	0	0	0.0030	0.4155	0.0723	0.0004
525	0	0	0.7345	0	0.7715	0.7932	740	0	0	0.0026	0.6300	0.0619	0.0003
530	0	0	0.8430	0	0.7500	0.8620	745	0	0	0.0025	0.8150	0.0558	0.0002
535	0	0	0.9065	0	0.7250	0.9149	750	0	0	0.0023	1.0000	0.0497	0.0001
540	0	0	0.9700	0	0.7000	0.9540	755	0	0	0.0020	0.9595	0.0416	0.0001
545	0	0	0.9850	0	0.6785	0.9803	760	0	0	0.0018	0.9190	0.0335	0.0001
550	0	0	1.0000	0	0.6570	0.9950	765	0	0	0.0017	0.8495	0.0292	0
555	0	0	0.9665	0	0.6385	1.0002	770	0	0	0.0016	0.7800	0.0249	0
560	0	0	0.9330	0	0.6200	0.9950	775	0	0	0.0014	0.6620	0.0206	0
565	0	0	0.8685	0	0.6030	0.9786	780	0	0	0.0013	0.5440	0.0162	0
570	0	0	0.8040	0	0.5860	0.9520	785	0	0	0.0012	0.4890	0.0144	0
575	0	0	0.7195	0	0.5700	0.9154	790	0	0	0.0012	0.4340	0.0125	0
580	0	0	0.6350	0	0.5540	0.8700	795	0	0	0.0012	0.3720	0.0107	0
585	0	0	0.5525	0	0.5385	0.8163	800	0	0	0.0011	0.3100	0.0088	0
590	0	0	0.4700	0	0.5230	0.7570	805	0	0	0.0005	0.2675	0.0075	0
595	0	0	0.3950	0	0.5060	0.6949	810	0	0	0	0.2250	0.0062	0
600	0	0	0.3200	0	0.4890	0.6310	815	0	0	0	0.1125	0.0031	0
605	0	0	0.2630	0	0.4750	0.5668	820	0	0	0	0	0	0
610	0	0	0.2060	0	0.4610	0.5030							

## 4. DATA COLLECTION METHODS

During Project OPAQUE I, two independent activities were maintained simultaneously. The operation of the airborne instrument system was one activity and that of the ground-based instrument system was the other. The procedural routine was for each system to run full data collection sequences at every opportunity, on a daily schedule, as weather permitted.

### 4.1 AIRBORNE SYSTEM

The data collection sequence for the airborne system was broken into five standardized elements: (1) preflight warmup and calibration check, (2) straight and level sequences, (3) vertical profile sequences, (4) in-flight calibration checks, and (5) post-flight calibration check.

An illustration of our typical flight pattern which was used for most OPAQUE I flights, is shown in Fig. 4-1. In this stylized pattern, two basic elements, the straight and level (ST&LV) and the vertical profile (V-PRO), are combined to yield the total mission flight plan. A description of these two pattern elements and the calibration elements is detailed in AFCRL-72-0255, Duntley, *et al.* (1972a), modified in AFCRL-54-75-0457, Duntley, *et al.* (1975b), and summarized in the following paragraphs.

1. Straight and Level runs (ST&LV), Mode 03 – The ST&LV runs are primarily  $2\pi$  scanner runs. The measurement of upper and lower hemisphere radiance distributions has top priority. One sky mode scanner pattern (192 seconds) plus one sun mode scanner pattern (64 seconds) are run at each altitude with each of the two optical filters.

During ST&LV runs the aircraft should maintain a fixed heading, a constant indicated airspeed of 150 knots or less, and a  $2\frac{1}{2}$ -degree nose-high flight attitude.

2. Vertical Profile runs (V-PRO), Mode 07 – The V-PRO runs are primarily integrating nephelometer and variable path function meter runs. The measurement of the total scattering coefficient profile has top priority. Second priority is measurement of the vertical path function profile. Each V-PRO ascent or descent is made using a single filter.

During the V-PRO runs the aircraft should maintain a fixed heading, with the sun off the left wingtip, and a flight attitude not exceeding 4 degrees nose down or 8 degrees nose up.

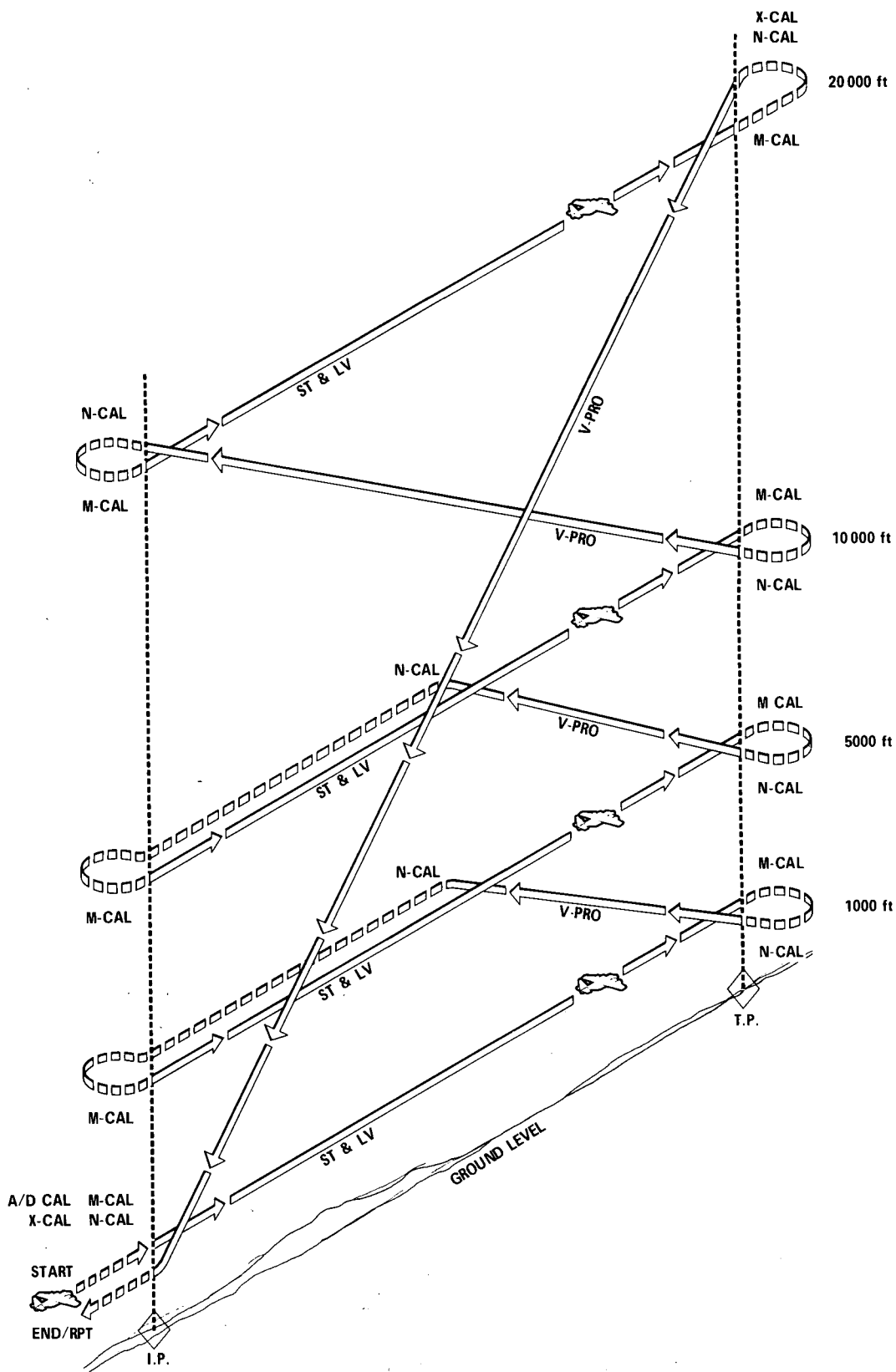

Fig. 4-1. Typical Visibility Laboratory Flight Profile.

An average rate of climb or descent of 1200 feet/minute is optimum, and airspeed is not critical, but should remain constant once established.

3. Cross-Calibration Climbs (X-CAL), Mode 08 – The X-CAL climbs are specifically designed to validate the performance of the UHS, LHS, and ERT radiometer systems. The simultaneous measurement of a common uniform segment of sky by these three radiometers has top priority. Two X-CAL climbs are associated with each standard profile, one preceding the first ST&LV run and the second following the last ST&LV run. Both sky mode and sun mode measurements are made with the UHS system.

During the 4-minute X-CAL climb the aircraft should maintain a fixed heading, with the sun in the aft hemisphere, and a 5-degree nose-high flight attitude. The aircraft should be flown directly toward the clearest and most uniform portion of the sky as practical.

4. Calibration Blocks (A/D CAL), Mode 00, M-CAL, Mode 01, N-CAL, Mode 09 – The 32-second blocks of calibration data are inserted periodically throughout the entire data mission. They are designed to provide calibration update information to the post-flight computer processing sequences. There are 21 assorted calibration blocks associated with each (2 + 4) profile.

During these calibration blocks there are no project-imposed requirements upon aircraft speed or attitude.

## GENERAL FLIGHT PATTERN

The standard (2 + 4) profile is illustrated in Fig. 4-1. In this profile, ST&LV data runs are made using two different spectral filters at each of four altitudes. The ascent V-PRO is made using the first of the two filters, and the descent V-PRO is made using the second. After the descent V-PRO, the entire sequence is repeated using a second pair of filters.

The idealized flight profile would result in all ground tracks falling on a single line running between the Initial Point (I.P.) and the Turning Point (T.P.). See Fig. 4-1. In practice, the ST&LV elements are actually stacked in a slab of atmosphere approximately 30 miles long, 0.5 mile wide, and 4 miles high.

Periodically, in response to specialized data requirements or weather conditions, supplementary flight patterns are added to the mission profile. For OPAQUE I, a pattern made up of a (2+3) profile, i.e., two spectral filters at each of three altitudes was used as was a (2+2) profile, i.e., two spectral filters at each of two altitudes. Both the (2+3) and (2+2) profiles are generally considered low to medium altitude profiles, and are normally used on flights performed under a full overcast or low to intermediate level cloud decks.

At the conclusion of each mission, the radiometric data which were recorded and stored on magnetic tape were returned to the Visibility Laboratory for computer reduction and analysis.

## 4.2 GROUND-BASED SYSTEM

The ground-based data collection sequence was designed to supplement the airborne data whenever the aircraft was operating in the immediate vicinity. However, it is also complete enough to stand alone when the aircraft mission is diverted or aborted.

During the OPAQUE I deployment, only the fly-away Contrast Reduction Meter (CRM) kit was available as a ground station. The primary function of the CRM system is to determine the earth-to-space beam transmittance for comparison with the data from the airborne systems. The basis for the measurement techniques utilizing the CRM was first presented by Gordon, *et al.* (1963) and validated by Duntley, *et al.* (1964). It is also discussed in Edgerton (1967) and summarized in Gordon, *et al.* (1973). A similar configuration of the device is described in Duntley, *et al.* (1970b).

The operational and computational procedures related to the CRM system are described in detail in Duntley, *et al.* (1972b), and briefly summarized in the following paragraph.

Four basic measurements using the CRM are required in order to provide proper inputs to the computation of earth-to-space universal contrast transmittance. They are:

1. Apparent Solar Radiance.
2. Path Radiance, i.e., Sky Radiance, at an appropriate scattering angle from the sun.
3. Total Downwelling Irradiance.
4. Inherent Background Radiance, i.e., generally a selected terrain radiance.

Since the CRM is conceived as a clear day system, requiring clear skies, its daily data collection schedule was often cut short, or aborted by poor weather during the OPAQUE I deployment. Under highly variable weather conditions, priority is assigned to measurements of apparent solar radiance in order to retrieve a maximum number of determinations for atmospheric beam transmittance. These measurements are recorded manually for subsequent insertion into the automatic data processing and evaluation procedure.

## 5. DATA PROCESSING

As in any reasonably complex, multi-input sampled data system, there is a large amount of data handling required before the scientific analyst ever sees the package. The degree of data processing sophistication utilized during this contract interval is illustrated in Fig. 5-1 and 5-2. In these generalized flow charts, the basic functional steps used in the data processing of the raw field data are clearly specified. They do not illustrate, however, all of the miscellaneous routines used for data base management and special diagnostic purposes. A more complete description of each phase of the processing sequence is contained in AFCRL-72-0255, AFCRL-72-0593, Duntley, *et al.* (1972a and c), and AFCRL-TR-75-0457, Duntley, *et al.* (1975b).

### 5.1 AIRBORNE DATA

As described in AFCRL-72-0255, Duntley, *et al.* (1972a), several classes of data are recorded during an airborne data set: (1) radiometer outputs, (2) selector control codes, (3) transducer orientation and flight attitude signals, and (4) calibration voltages, etc. All systems, regardless of type, have been designed for an electrical output between 0 and  $\pm 1$  volt dc for full scale. The 42-channel data logger has a least count of  $\pm 1$  millivolt and records in digital format at a multiplex rate of 240 samples per second and a tape rate of 3.56 inches per second at a recording density of 200 bits per inch.

Several major improvements to the airborne data processing procedure have been implemented during the interval since AFCRL-72-0593, Duntley, *et al.* (1972c) and AFCRL-54-75-0457, Duntley, *et al.* (1975b). The insertion of these programs is summarized in AFGL-TR-76-0188, Duntley, *et al.* (1976) and is illustrated in Fig. 5-1. These programs, and the increased diagnostic capabilities that their usage has enabled, have materially improved the quality of the upper hemisphere radiance maps, and thus the quality of all subsequently computed optical atmospheric properties.

In order to produce the data included in this short form report, it was not necessary to run the programs illustrated in the upper portion of Fig. 5-1. That is, those programs related to the processing of automatic scanner data, MIRESCAN, SCANTSUM, etc., were bypassed. In this manner the AVIZC130 runs were shortened to only the first overlay for the production of scattering coefficient and beam transmittance profiles.

### 5.2 GROUND-BASED DATA

Only the CRM system was used for the collection of ground-based data and its output was manually

AIRBORNE DATA PROCESSING:

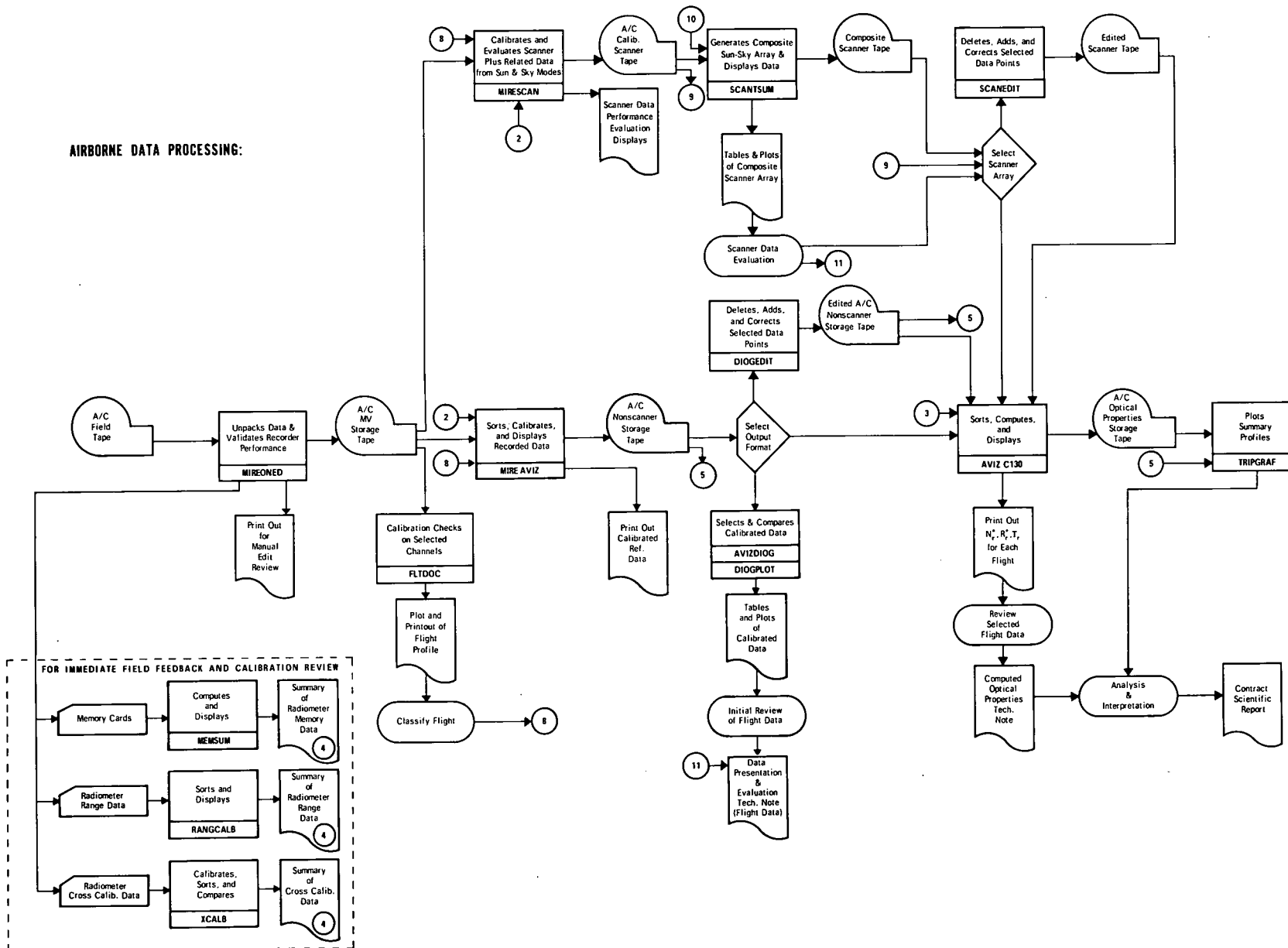
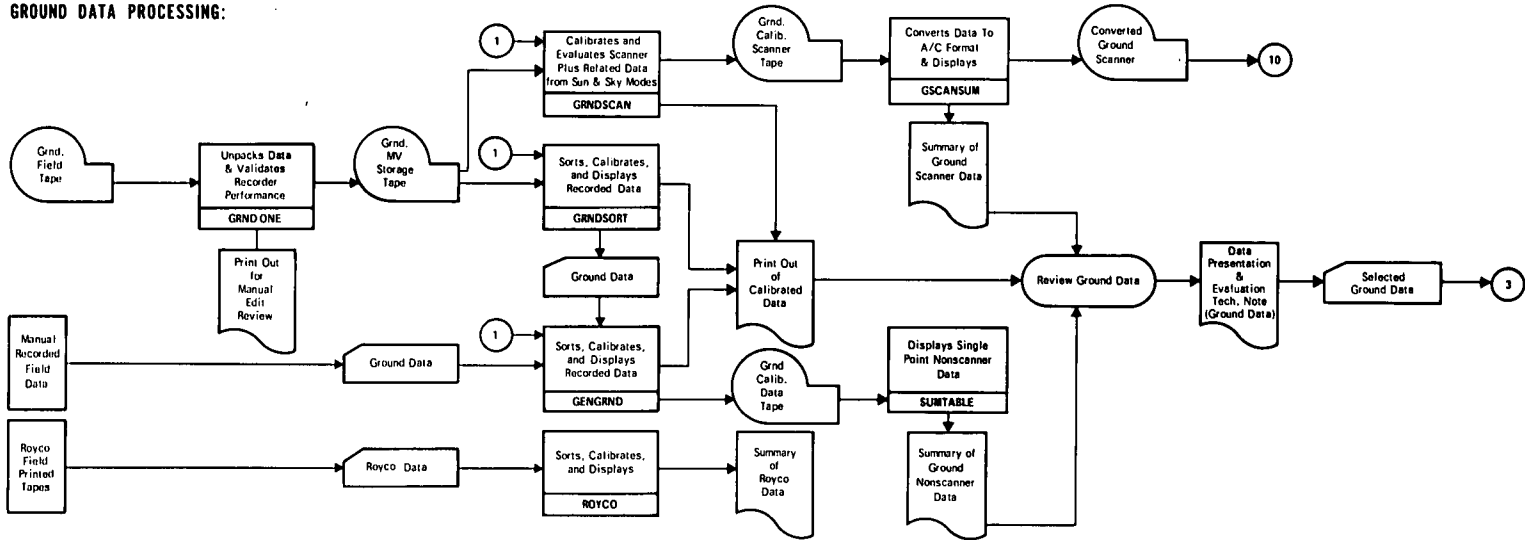

Fig. 5-1. Atmospheric Visibility Program Data Processing Schedule.

**GROUND DATA PROCESSING:**



**CALIBRATION DATA PROCESSING:**

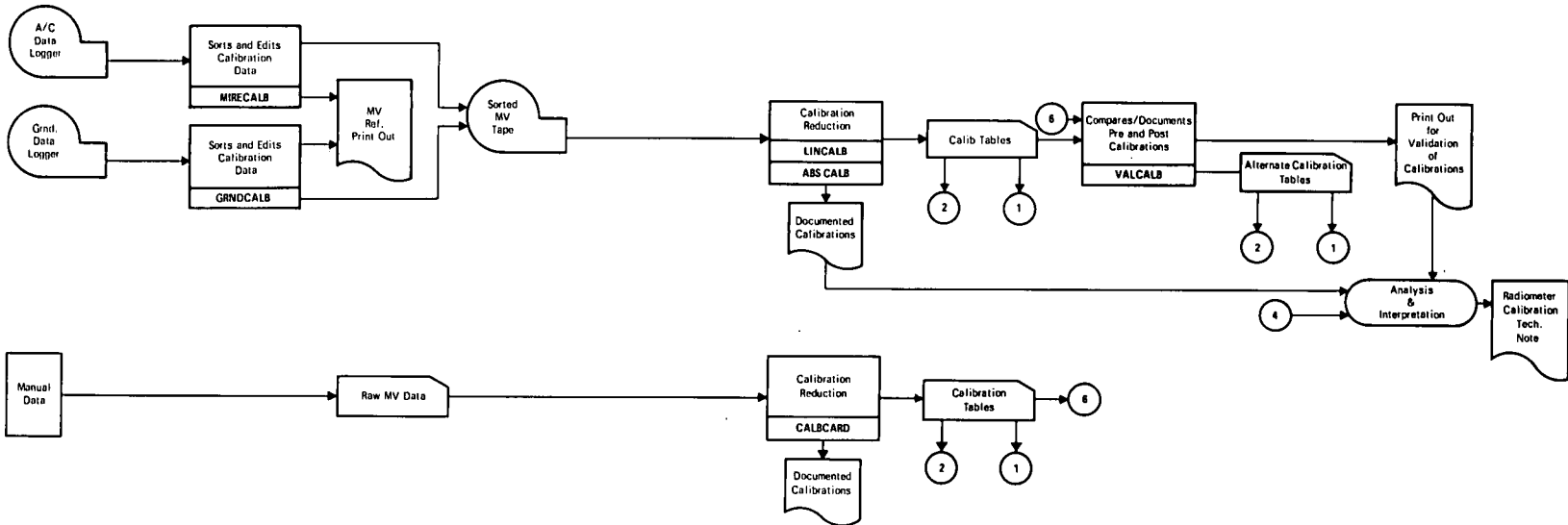

Fig. 5-2. Atmospheric Visibility Program Data Processing Schedule.

recorded. Due to the relatively small quantities of ground data acquired during OPAQUE I, no automatic processing has been required.

### 5.3 CALIBRATION DATA

The calibration data are the heart of the data processing system in that any data processed are only as good as the calibrations applied to them. The pre- and post-deployment calibration data are recorded on tape in an effort to eliminate the human bias and are handled in a phased procedure similar to that used in the general data processing technique. The data can be recorded on either the airborne or the ground data logging system. In an initial procedure, these data go through Program MIRECALB or GRNDALB, according to the recording system used, to verify the electrical quality of the radiometer data and associated monitored parameters. For final processing, the data are sorted and stored in set fashion.

The details of processing the calibration data according to the procedure illustrated in Fig. 5-2 are described in our preceding reports, AFCRL-72-0593, Duntley, *et al.* (1972c), AFCRL-TR-75-0457, Duntley, *et al.* (1975a) and AFCRL-TR-75-0414, Duntley, *et al.* (1975b), and will not therefore be discussed further herein.

### 5.4 DATA TAPES

The data processing sequences referenced in the previous paragraphs produce output tapes containing a broad catalog of calibrated data. These tapes are useable as data inputs to a multiplicity of diverse problems requiring a knowledge of atmospheric optical properties. To simplify future retrieval, the data tape numbers, and the in-house descriptions of the data reported herein have been summarized in Table 5.1.

**Table 5.1**  
Data Library Composite Tape Summary

OPAQUE I Flight No.	DIOGEDIT Tape No. VL-389G File No.	Data Presentation No.	Edited Properties No.
C-372	2	139	140
C-373	3	139	140
C-376	6	139	140
C-377	7	139	140
C-378	8	139	140
C-379	9	139	140
C-381	11	139	140
C-382	12	139	140

## 6. WEATHER SUMMARY

### 6.1 INTRODUCTION AND GRAPHICS

Meteorological data available for analysis included daily surface and 500-millibar charts obtained from the Environmental Technical Applications Center (ETAC) at Scott Air Force Base. The surface charts were for 6-hour intervals and the 500-millibar charts were for 0000 GMT and 1200 GMT. Northern hemisphere surface charts for 1200 GMT prepared by the National Oceanographic Atmospheric Administration were obtained from the National Climatic Center in Asheville. Portions of these charts have been reproduced as Fig. 6-1. The approximate flight track locations are indicated in Fig. 6-1 with the symbol ☆. Also utilized were radiosonde data from locations near each of the flight tracks and nephanalyses prepared by ETAC. Tabular data for the hourly observations from nearby weather stations were also utilized.

The measurements of temperature and dewpoint temperature taken on the aircraft, and the computed relative humidity are presented in Figs. 6-2 and 6-3. The temperatures were measured continuously by an AN/AMQ-17 aerograph system described briefly in AFCRL-70-0137, Duntley, *et al.* (1970a) and more completely in USNAF TP-133. The dewpoint/frostpoint temperatures were measured using a Cambridge 137-C3 Aircraft Hygrometer System which is described briefly in AFCRL-72-0593, Duntley, *et al.* (1972c).

The profile identification symbols used in Figs. 6-2 and 6-3 are related to the spectral filter sequence during which the data were measured; i.e., the temperature profile identified with the Filter 2 symbol was taken during the same time interval as the Filter 2 radiometric measurements; the temperatures coded as Filter 3 were taken simultaneously with the Filter 3 radiometric measurements, etc. Table 6-1, abstracted from program FLTDOC listings, summarizes the beginning and ending times associated with each flight element during which these meteorological and radiometric measurements were made. The time separations between profiles are substantial and should be carefully considered when assessing the temporal stability of the subject airmass.

Radiosonde observations for 1200 GMT were available from sites near each of the flight tracks. The temperatures from the radiosonde station closest to each flight track have been plotted on the temperature plots in Fig. 6-2. The relative humidities, computed from RAOB temperature and dewpoint depression measurements are also shown on the plots in Fig. 6-3. The locations of the radiosonde stations are shown on the data site detail maps in Fig. 1-1. More detailed location information as well as the station identification code used in Fig. 6-2 and 6-3 is included in Table 6.2. Although the RAOB data are graphed with the C-130 data, it should be remembered that the two data sets are often remote in either space or time.

The geographical separations are also noted in the flight descriptions in Section 7.3, and the time separations may be determined by comparing the flight times noted in Tables 6.1 and 7.3 with the RAOB release time, 1200 GMT.

The daily flight descriptions which appear in Section 7.3 include a discussion of the weather characteristics and the synoptic situation at the surface and 500-millibar levels during each of the flights. The synoptic conditions are also summarized in Section 6.2.

**Table 6.1**

Flight Profile Elapsed Time Summary (From FLTDOC Listings)

Flight Number	Profile Flight Times (GMT)								Total Elapsed (VPRO ONLY)
	FILTER 2		FILTER 3		FILTER 4		FILTER 5		
	START	STOP	START	STOP	START	STOP	START	STOP	
C-372	1156	1255	1331	1343	1401	1509	1530	1538	3 hr 42 min
C-373	1109	1216	1237	1250	1309	1414	1435	1446	3 hr 37 min
C-376	0909	1014	1034	1047	1106	1208	1229	1240	3 hr 21 min
C-377	0918	1021	1049	1100	1121	1223	1241	1253	3 hr 35 min
C-378	0956	1000	1021	1025	1050	1054	1115	1118	1 hr 22 min
C-379	1013	1107	1125	1138	1158	1259	1318	1332	3 hr 19 min
C-381	1112	1212	1258	1342	1230	1241	1405	1416	3 hr 04 min
C-382	0938	1023	—	—	1044	1056	—	—	1 hr 18 min

**Table 6.2**

Radiosonde Station Identification

Flight No.	Track Identification	Radiosonde Station	Range and Direction from Track Center	Fig. 6-1 and 6-2 Identification Code
C-372	Soesterberg	DeBilt	33 km NW	RAOB D
C-373	Yeovil	Crawley	160 km E	RAOB C
C-376	Yeovil	Crawley	160 km E	RAOB C
C-377	Yeovil	Crawley	160 km E	RAOB C
C-378	Rodby	Schleswig	106 km W	RAOB S
C-379	Rodby	Schleswig	106 km W	RAOB S
C-381	Meppen	Rheine/Waldhugel	81 km S	RAOB R
C-382	Meppen	Rheine/Waldhugel	81 km S	RAOB R

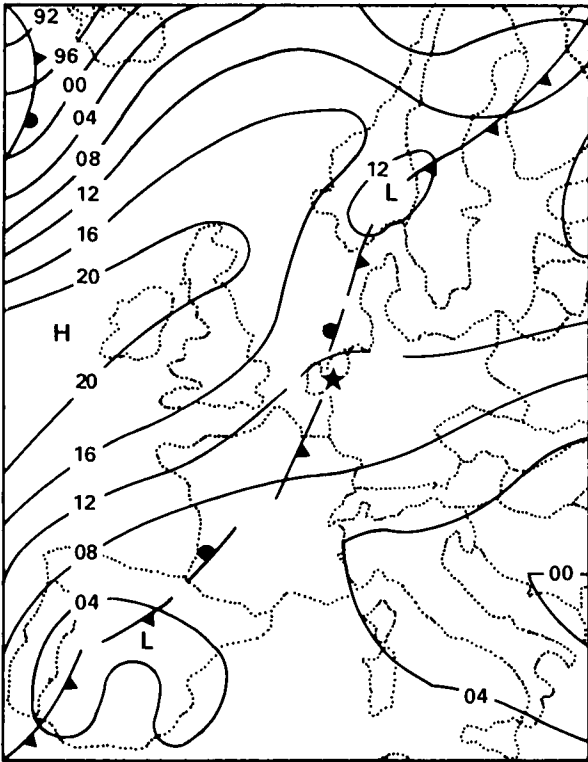

12 APRIL 1976 1200 GMT

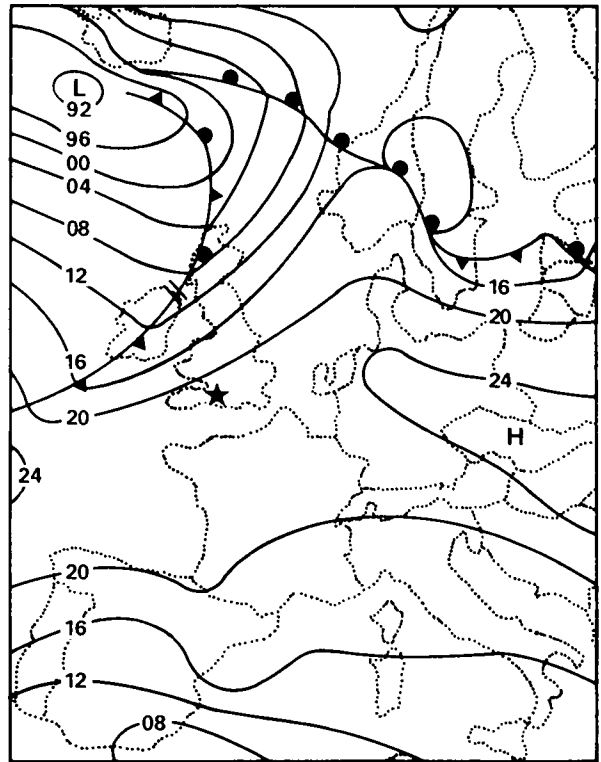

1 MAY 1976 1200 GMT

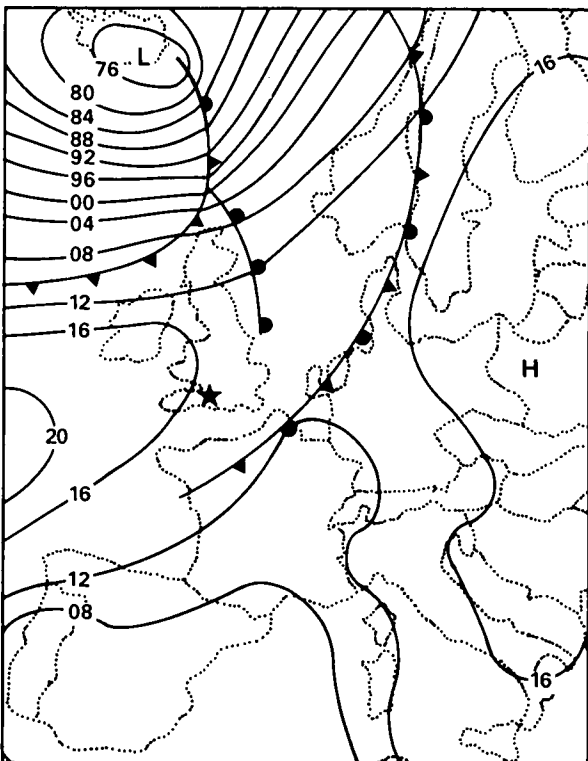

8 MAY 1976 1200 GMT

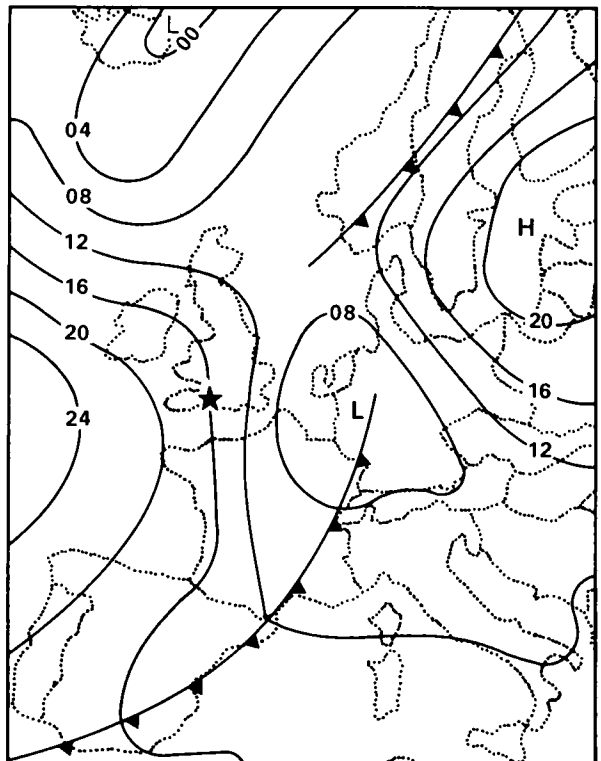

10 MAY 1976 1200 GMT

Fig. 6-1. Synoptic Surface Charts of European Area During Project OPAQUE I.

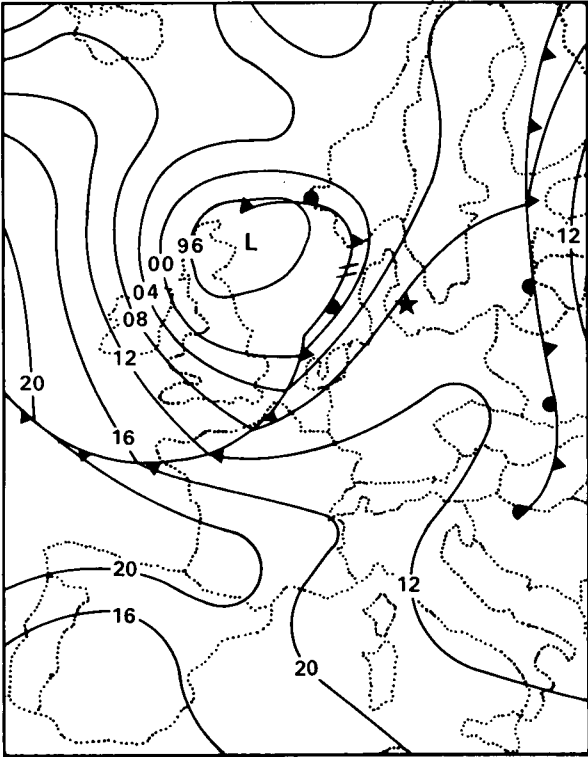

12 MAY 1976 1200 GMT

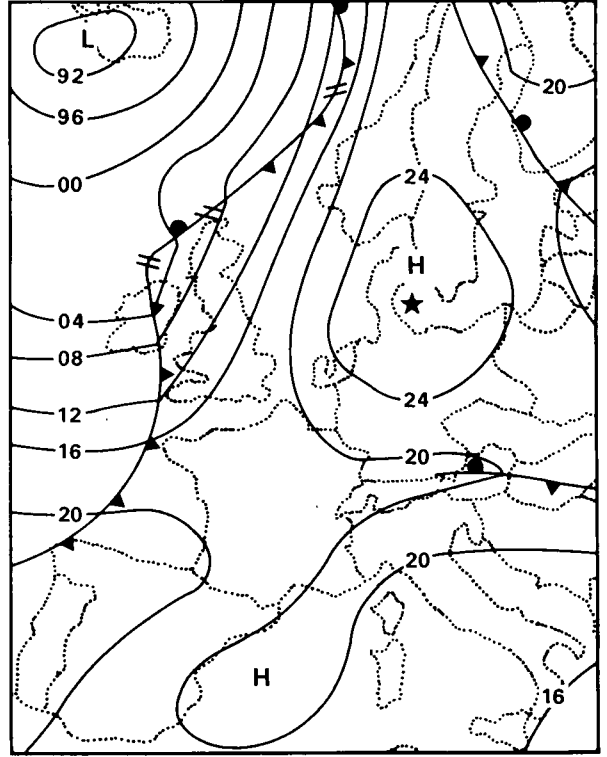

17 MAY 1976 1200 GMT

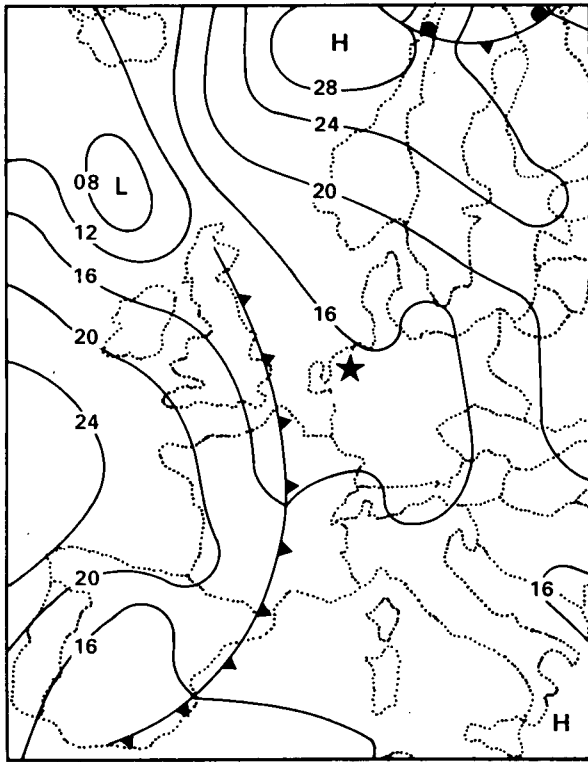

25 MAY 1976 1200 GMT

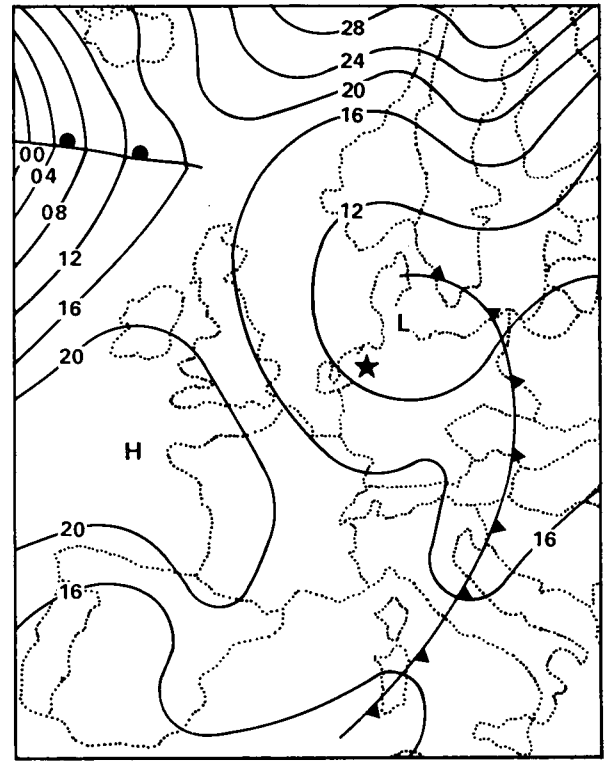

26 MAY 1976 1200 GMT

Fig. 6-1 (cont). Synoptic Surface Charts of European Area During Project OPAQUE I.

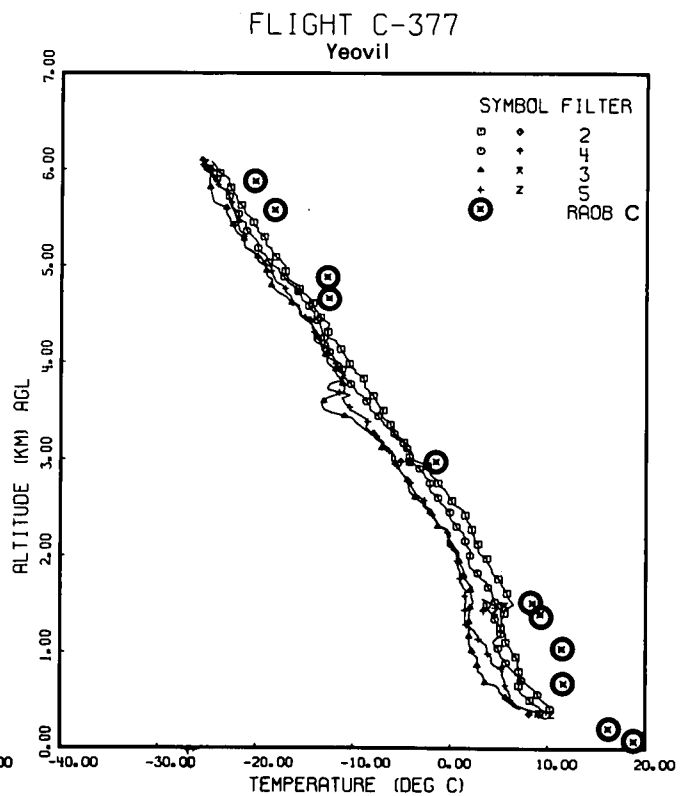
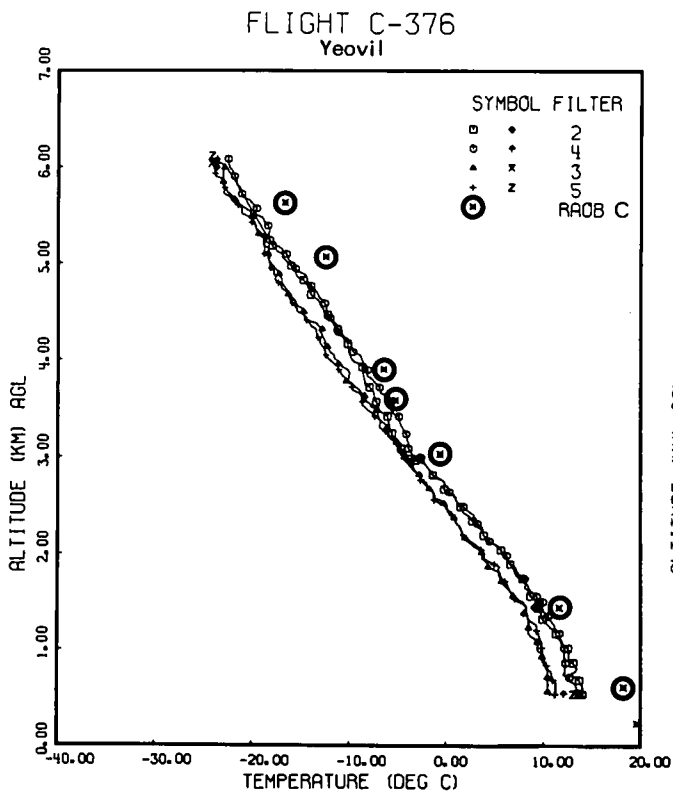
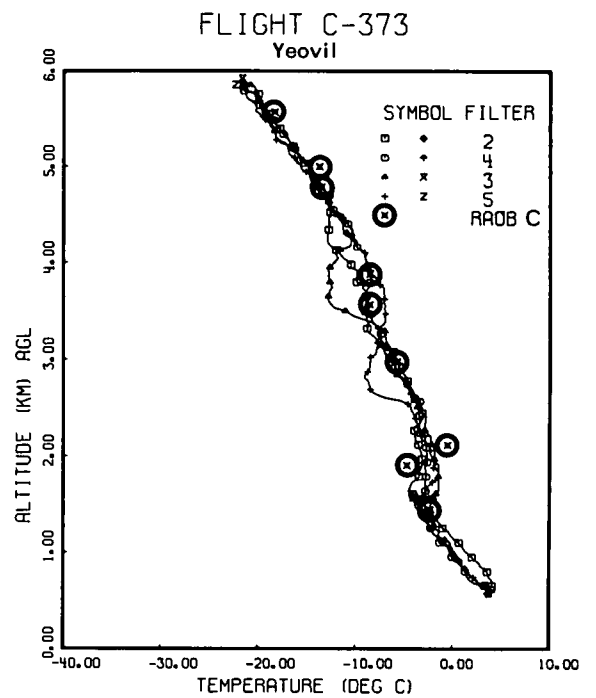
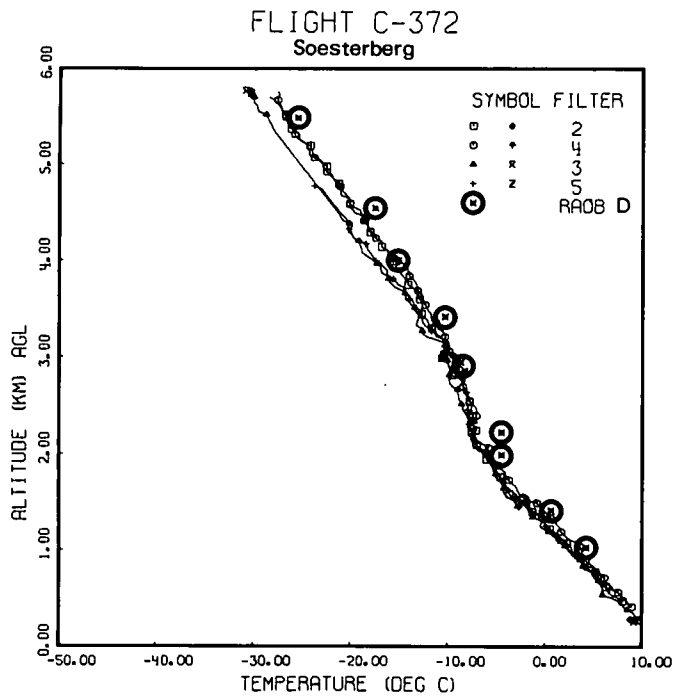

Fig. 6-2. Temperature Versus Altitude for Eight Project OPAQUE I Flights.

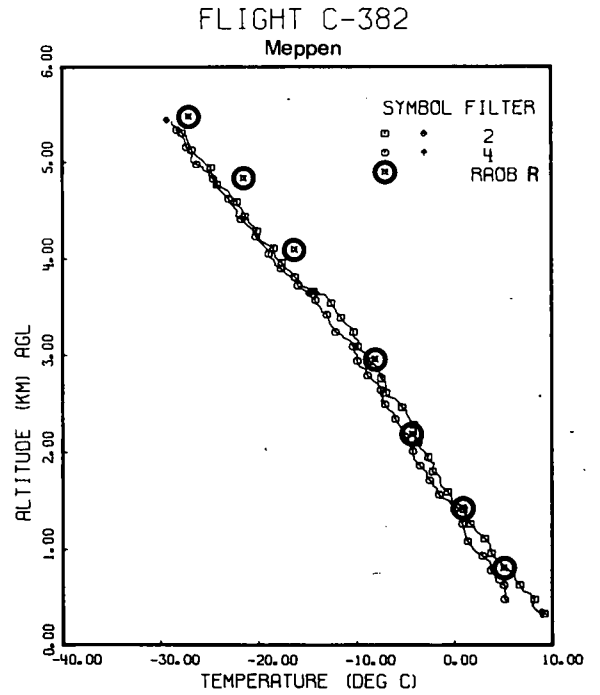
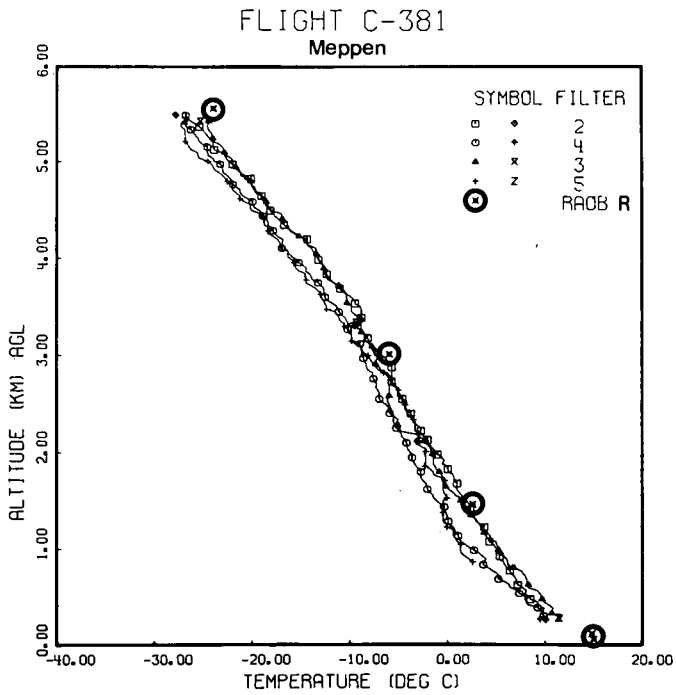
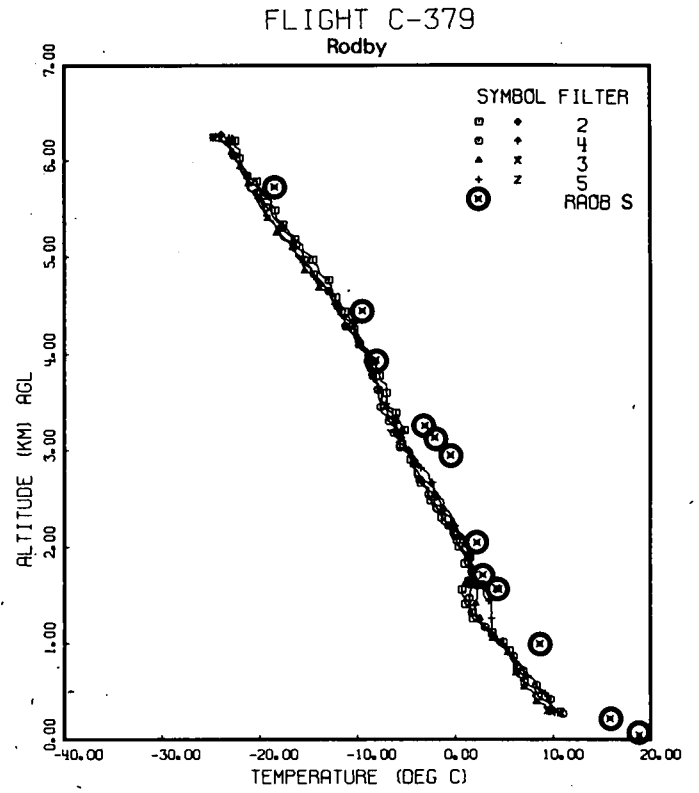
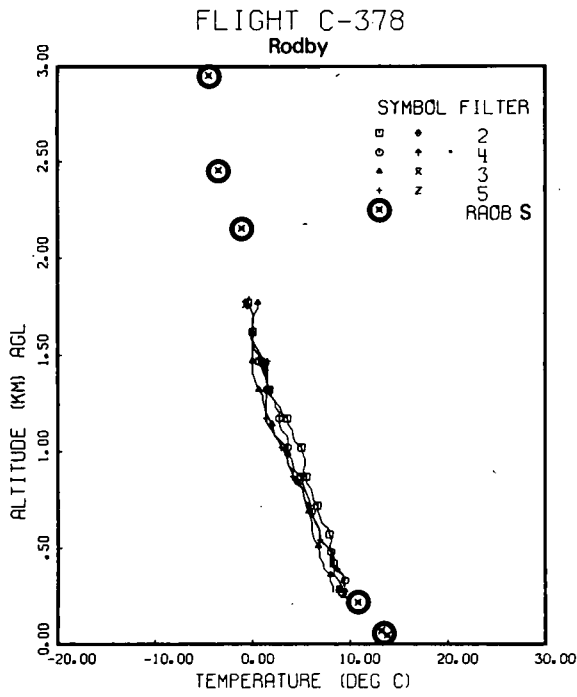

Fig. 6-2 (cont). Temperature Versus Altitude for Eight Project OPAQUE I Flights.

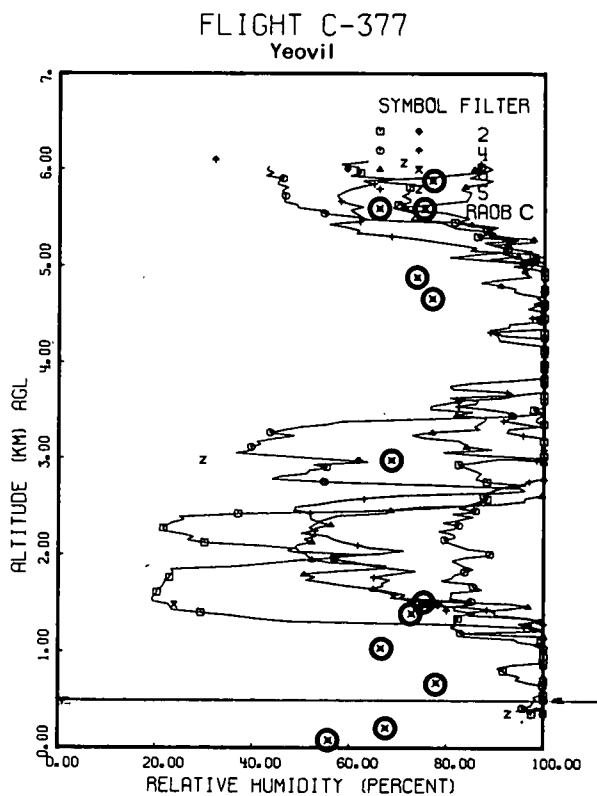
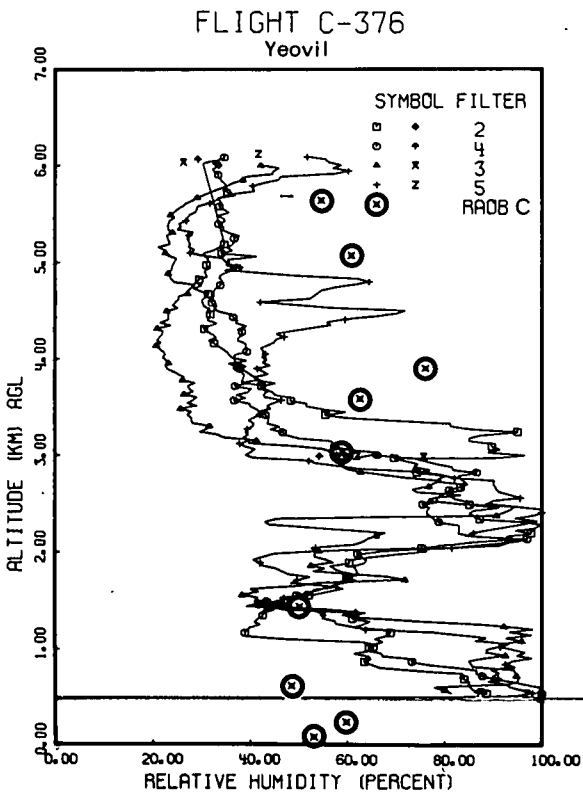
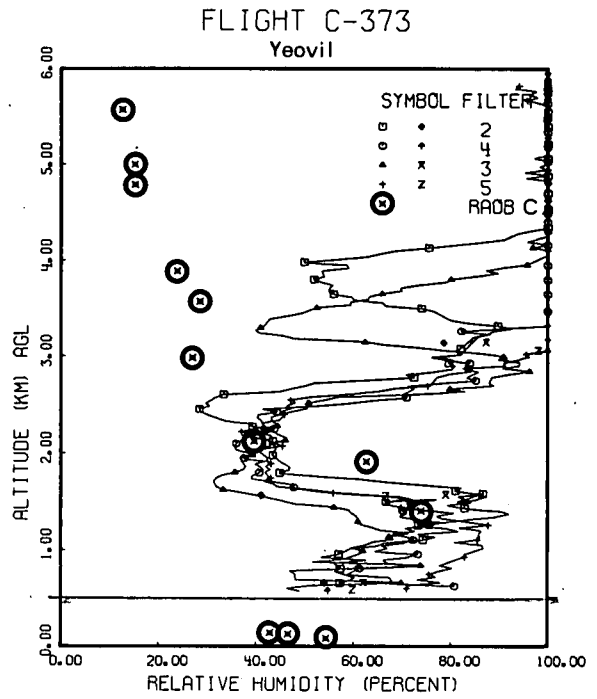
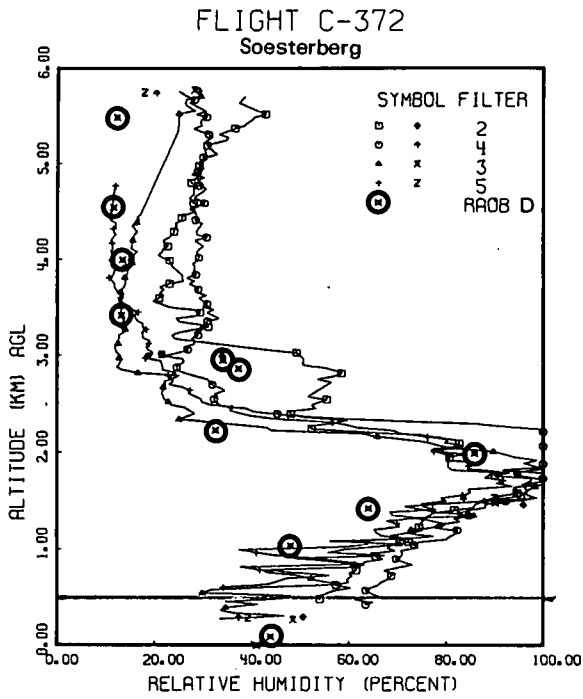

Fig. 6-3. Relative Humidity Versus Altitude for Eight Project OPAQUE I Flights.

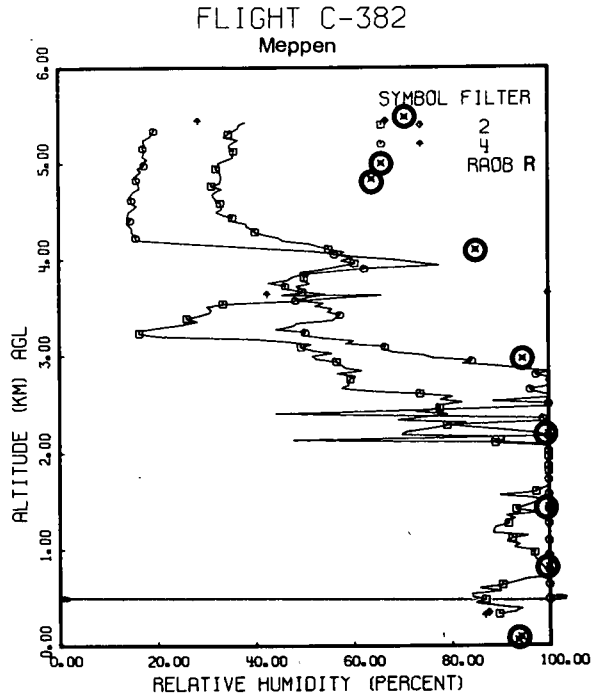
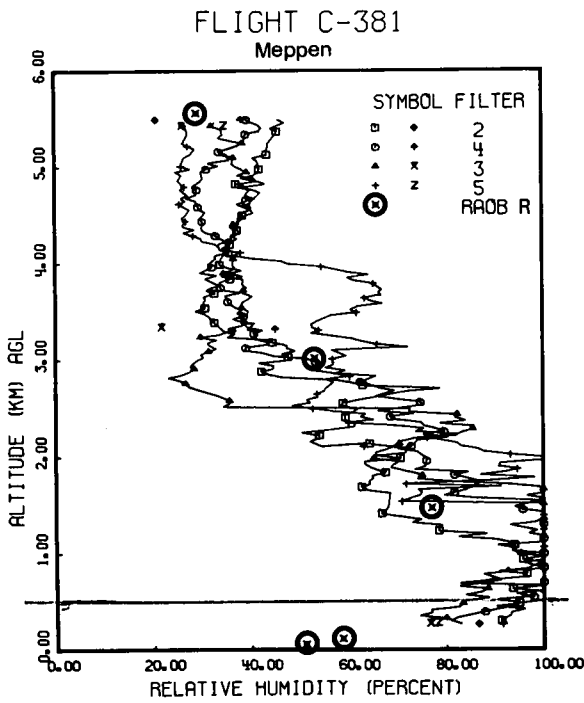
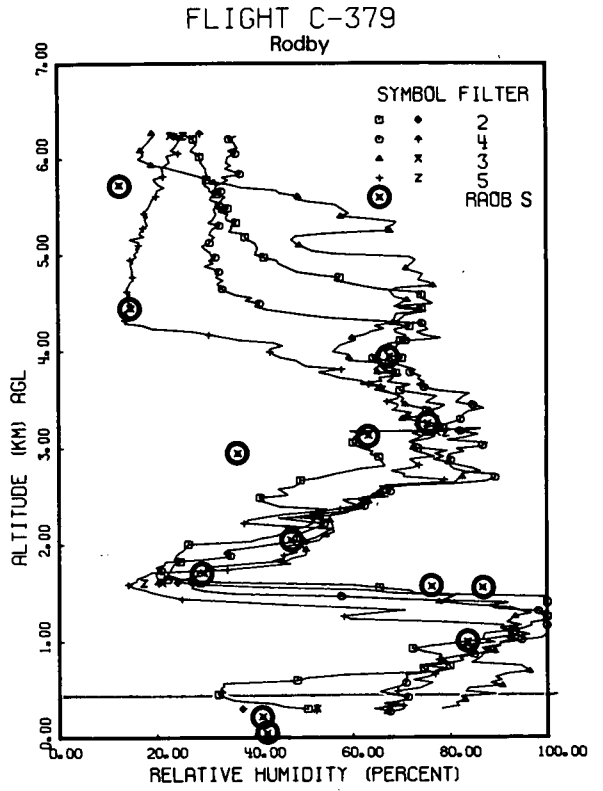
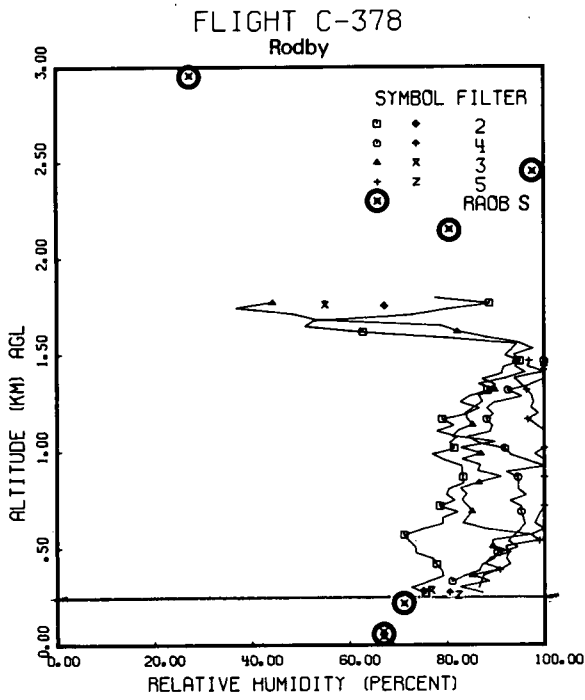

Fig. 6-3 (cont). Relative Humidity Versus Altitude for Eight Project OPAQUE I Flights.

Tabular listings of the hourly observation data for weather stations nearest each flight track are included in Table 6.1, Section 6.3.

During each of the flights except C-372 an on-board meteorologist made and recorded observations concerning the cloud and haze conditions, shadows, visibility of the solar disc, and slant path visibilities from various altitudes. Some of these observations are included in the tables in Section 6.3 and the flight descriptions in Section 7.3. These in-flight observations have been very useful in evaluating and confirming the data recorded by the airborne instrument systems.

## 6.2 SYNOPTIC CONDITIONS

### FLIGHT C-372 ON 12 APRIL 1976

The surface charts show a dissipating stationary front extending southsouthwest from Scandinavia to central Spain. The center of the Atlantic High was located southwest of the Azores. At 500 millibars the Denmark-Germany area was in a col with light easterly winds. The airmass was stable continental polar.

### FLIGHT C-373 ON 1 MAY 1976

The surface charts show an occluded system passing from Ireland through Britain throughout the day. The warm front part of this system was approaching the track during the flight but was weak. High pressure was centered over Belgium at 0600 GMT and moved to Luxemburg by 1800 GMT. The 500-millibar charts show the area in a col with light and variable winds. The airmass was stable continental polar.

### FLIGHT C-376 ON 8 MAY 1976

The surface charts show an occluded front passing Mildenhall about 0600 GMT moving into the North Sea and weakening at 1200 GMT. Another cold front was approaching the west coast of Ireland. At 500 millibars there was a blocking stationary high over western Germany with light southwesterly flow over Britain. The airmass was unstable maritime polar.

### FLIGHT C-377 ON 10 MAY 1976

The surface charts show that a cold front passed through the southern part of England shortly after 0600 GMT. At 1200 GMT a cold front extended from central Germany southwestward to Gibraltar and into the Atlantic. At 500 millibars there was a trough through Ireland and the Irish Sea at 1200 GMT. This trough produced southsouthwesterly flow over southern England. The airmass was unstable maritime polar.

### FLIGHT C-378 ON 12 MAY 1976

The surface chart for 1200 GMT shows a low in the North Sea. A cold front, part of this system, extended southwestward through the English channel. At 500 millibars the flight area was in transitional area from ridge to trough with moderate southwesterly winds. The airmass was stable maritime polar.

#### FLIGHT C-379 ON 17 MAY 1976

The surface chart for 1200 GMT shows a closed high cell centered near Kiel Bay. A cold front was moving from Ireland to Britain through the Irish Sea. At 500 millibars there was weak ridging from Sardinia to Sweden with light northwesterly winds. The airmass was stable maritime polar.

#### FLIGHT C-381 ON 25 MAY 1976

The surface charts show a weak pressure gradient over Germany. A weakening cold front extended along a line from Edinburgh to Calais to Valencia. At 500 millibars there was a closed low over northwestern Germany at 0000 GMT. By 1200 GMT this low had filled and there was a trough from the British Isles to northwestern Germany. Winds were moderate westerly. Airmass was stable maritime polar.

#### FLIGHT C-382 ON 26 MAY 1976

The surface chart for 1200 GMT shows a cold front extended from near Oslo through eastern Poland and Central Italy into the Mediterranean. At 500 millibars there was an open low in the North Sea with northwestern Germany on the leading edge of a trough with moderate southwesterly flow. The airmass was unstable maritime polar.

### **6.3 TABULAR SUMMARY AND GLOSSARY**

A summary of the daily meteorological observations taken at the weather stations nearest each flight track on the days during which data flights were made is presented in Table 6.3. A glossary of the most often used symbols is also included. All data were reported in Greenwich Civil Time (GCT) which is equivalent to Greenwich Mean Time (GMT), the terminology used in Table 6.3.

# METEOROLOGICAL GLOSSARY AND ABBREVIATIONS

<p style="text-align: center;"><b>SKY AND CEILING</b></p>	<p style="text-align: center;"><b>VISIBILITY (VV)</b></p>																								
<p>Sky cover symbols are in ascending order. Figures preceding symbols are heights in hundreds of feet above station. Sky cover symbols are:</p> <ul style="list-style-type: none"> <li>○ Clear: less than 0.1 sky cover</li> <li>⊙ Scattered: 0.1 to less than 0.6 sky cover</li> <li>⊕ Broken: 0.6 to 0.9 sky cover</li> <li>⊖ Overcast: more than 0.9 sky cover               <ul style="list-style-type: none"> <li>- Thin (when prefixed); light (when suffixed)</li> <li>-- Very light (when suffixed)</li> </ul> </li> <li>-X Partial obscuration: 0.1 to less than 1.0 sky hidden by precipitation or obstruction to vision (bases at surface)</li> <li>X Obscuration: 1.0 sky hidden by precipitation or obstruction to vision (bases at surface)</li> </ul> <p>Letter preceding height of layer identifies ceiling layer and indicates how ceiling height was obtained. Thus:</p>	<p>Reported in kilometers.</p>																								
<ul style="list-style-type: none"> <li>A Aircraft</li> <li>B Balloon (pilot or ceiling)</li> <li>D Estimated height of cirriform clouds on basis of persistency</li> <li>E Estimated height of noncirriform clouds</li> <li>M Measured</li> <li>R Radiosonde balloon or radar</li> <li>U Height of cirriform ceiling layer unknown</li> <li>V Immediately following numerical value indicates a varying ceiling (also used with varying visibility)</li> <li>W Indefinite, sky obscured by surface base phenomenon. e.g. fog, blowing dust, snow</li> </ul>	<p style="text-align: center;"><b>WEATHER AND OBSTRUCTION TO VISION SYMBOLS</b></p> <table border="0" style="width: 100%;"> <tr> <td style="width: 50%;">A Hail</td> <td style="width: 50%;">IF Ice fog</td> </tr> <tr> <td>AP Small hail</td> <td>K Smoke</td> </tr> <tr> <td>BD Blowing dust</td> <td>L Drizzle</td> </tr> <tr> <td>BN Blowing sand</td> <td>R Rain</td> </tr> <tr> <td>BS Blowing snow</td> <td>RW Rain showers</td> </tr> <tr> <td>D Dust</td> <td>S Snow</td> </tr> <tr> <td>E Sleet</td> <td>SG Snow grains</td> </tr> <tr> <td>EW Sleet showers</td> <td>SP Snow pellets</td> </tr> <tr> <td>F Fog</td> <td>SW Snow showers</td> </tr> <tr> <td>GF Ground fog</td> <td>T Thunderstorms</td> </tr> <tr> <td>H Haze</td> <td>ZL Freezing drizzle</td> </tr> <tr> <td>IC Ice crystals</td> <td>ZR Freezing rain</td> </tr> </table>	A Hail	IF Ice fog	AP Small hail	K Smoke	BD Blowing dust	L Drizzle	BN Blowing sand	R Rain	BS Blowing snow	RW Rain showers	D Dust	S Snow	E Sleet	SG Snow grains	EW Sleet showers	SP Snow pellets	F Fog	SW Snow showers	GF Ground fog	T Thunderstorms	H Haze	ZL Freezing drizzle	IC Ice crystals	ZR Freezing rain
A Hail	IF Ice fog																								
AP Small hail	K Smoke																								
BD Blowing dust	L Drizzle																								
BN Blowing sand	R Rain																								
BS Blowing snow	RW Rain showers																								
D Dust	S Snow																								
E Sleet	SG Snow grains																								
EW Sleet showers	SP Snow pellets																								
F Fog	SW Snow showers																								
GF Ground fog	T Thunderstorms																								
H Haze	ZL Freezing drizzle																								
IC Ice crystals	ZR Freezing rain																								
	<p style="text-align: center;"><b>CLOUD ABBREVIATIONS</b></p> <table border="0" style="width: 100%;"> <tr> <td style="width: 50%;">Ac Altocumulus</td> <td style="width: 50%;">Cs Cirrostratus</td> </tr> <tr> <td>As Altostratus</td> <td>Cu Cumulus</td> </tr> <tr> <td>Cb Cumulonimbus</td> <td>Ns Nimbostratus</td> </tr> <tr> <td>Cc Cirrocumulus</td> <td>Sc Stratocumulus</td> </tr> <tr> <td>Ci Cirrus</td> <td>St Stratus</td> </tr> </table>	Ac Altocumulus	Cs Cirrostratus	As Altostratus	Cu Cumulus	Cb Cumulonimbus	Ns Nimbostratus	Cc Cirrocumulus	Sc Stratocumulus	Ci Cirrus	St Stratus														
Ac Altocumulus	Cs Cirrostratus																								
As Altostratus	Cu Cumulus																								
Cb Cumulonimbus	Ns Nimbostratus																								
Cc Cirrocumulus	Sc Stratocumulus																								
Ci Cirrus	St Stratus																								
<p style="text-align: center;"><b>RELATIVE HUMIDITY (RH)</b></p> <p>Reported in percent and computed from temperature and dewpoint.</p>	<p style="text-align: center;"><b>WIND</b></p> <p>Direction in ten's of degrees from true north, speed in meters per second (mps). A "0000" indicates calm. A "G" indicates gusty. A "Q" indicates squall. Peak speed of gusts, when reported, follows G or Q. The contraction WSHFT in remarks followed by time group (GMT) indicates wind shift and its time of occurrence.</p> <p>Examples: 0109 is 010 degrees, 9 mps.          3607G11 is 360 degrees, 7 mps, peak speed in gusts of 11 mps.</p>																								

Table 6.3

## STANDARD METEOROLOGICAL DATA SHEET

Flight No. C-372  
Date: 12 April 1976

Field Site: Soesterberg Track  
Lat. 51°56' N – Long. 5°35' E – El. 6 m

Time GCT	Sky and Ceiling (Hundreds of Feet)	Visibility (Kilometers)	Weather and Obstructions To Vision	Temp. (°C)	Dewpoint (°C)	Rel. Hum. (%)	Wind Direction   Speed (00–36)   (mps)		Remarks
SOESTERBERG (EHSB 06265) 52°08' N 5°16' E Elev. 20 m							North of track		
1200	50 ⊙	11.0		15.0	−1.0		02	5.7	1/8 Cu
1229		9.9		15.0	−1.0		09	3.0	
1300	50 ⊙	12.0		16.0	−1.0		03	5.1	3/8 Cu
1500	50 ⊙	25.0		15.0	−1.0		05	4.1	3/8 Sc
1600	50 ⊙	25.0		MSG	−1.0		05	6.7	3/8 Sc
1700	50 ⊙	25.0		14.0	−1.0		04	5.7	2/8 Sc
DEELEN (EHDL 06275) 52°04' N 5°53' E Elev. 48 m							North of track		
1200	30 ⊙	18.0		14.0	−3.0		08	6.2	2/8 Cu
1300	38 ⊙	18.0		15.0	−1.0		06	6.2	1/8 Cu
1400	42 ⊙	18.0		15.0	−1.0		06	5.1	3/8 Cu
1500	45 ⊙	20.0		14.0	−2.0		06	5.7	3/8 Cu
1600	50 ⊙	20.0		15.0	−2.0		06	5.7	3/8 Cu
1700	50 ⊙	18.0		14.0	−2.0		04	5.1	3/8 Sc

Table 6.3 (cont.)

## STANDARD METEOROLOGICAL DATA SHEET

Flight C-373

Date: 1 May 1976

Field Site: Yeovil Track

Lat. 50°56'N – Long. 2°27'W – El. 60m

Time GCT	Sky and Ceiling (Hundreds of Feet)	Visibility (Kilometers)	Weather and Obstructions To Vision	Temp. (°C)	Dewpoint (°C)	Rel. Hum. (%)	Wind		Remarks
							Direction (00–36)	Speed (mps)	
IN FLIGHT									
1130	45 ⊕ 280 ⊕	11.0							1/8 Cu 8/8 Cs Binovc E
1355	E140 ⊕ 250 ⊕	16.0							Few Cu 3/8 As 6/8 Cs
YEOVILTON (EGDY 038530) 51°00'N 2°38'W Elev. 23m North of track									
1100	E250 ⊕	8.0	H	13.0	9.0		21	7.7	7/8 Ci
1200	150-⊕ E200 ⊕	12.0	H	12.0	9.0		21	8.2	3/8 As 7/8 Cs
1300	150-⊕ E200 ⊕	15.0		13.0	9.0		21	9.3	3/8 As 7/8 Cs
1400	90 ⊕ E200 ⊕	15.0		13.0	10.0		21	9.8	3/8 Ac 6/8 Cs
1500	120-⊕ E200 ⊕	13.0		12.0	9.0		21	10.3	3/8 As 6/8 Cs
1600	E 50 ⊕ 120 ⊕	12.0		12.0	9.0		21	5.7	5/8 Sc 5/8 As
BOURNEMOUTH-HURN (EGHH 03862) 50°47'N 1°50'W Elev. 11m Southeast of track									
1100	40 ⊕ E250 ⊕	25.0		14.0	-4.0		22	5.7	1/8 Cu 6/8 Ci
1200	200 ⊕ E250 ⊕	25.0		14.0	-4.0		25	6.7	3/8 Cu 7/8 Ci
1300	160 ⊕ E250 ⊕	25.0		13.0	-1.0		21	7.2	2/8 As 7/8 Ci
1400	40 ⊕ 100 ⊕ E160 ⊕	25.0		13.0	-1.0		22	7.2	1/8 Sc 3/8 Ac 6/8 As
1500	100 ⊕ E200 ⊕	22.0		12.0	1.0		23	7.2	2/8 Ac 7/8 Cs
1600	120 ⊕ E200 ⊕	15.0		12.0	0.0		22	7.2	3/8 Ac 8/8 Cs

Table 6.3 (cont.)

## STANDARD METEOROLOGICAL DATA SHEET

Flight No. C-376

Date: 8 May 1976

Field Site: Yeovil Track

Lat. 50°56' N – Long. 2°27' W – El. 60 m

Time GCT	Sky and Ceiling (Hundreds of Feet)	Visibility (Kilometers)	Weather and Obstructions To Vision	Temp. (°C)	Dewpoint (°C)	Rel. Hum. (%)	Wind Direction (00–36)   Speed (mps)		Remarks
IN FLIGHT									
0900	-X250- ☉	3.0	H						2/8 Ci
0950	-X250- ☉	3.0	H						2/8 Ci
1055	-X250- ☉	4.0	H						1/8 Ci
1150	-X250- ☉	4.0	H						1/8 Ci
1220	-X 20 ☉ 250- ☉	4.0	H						1/8 Ci
YEOVILTON (EGDY 038530) 51°00' N 2°38' W Elev. 20 m <span style="float: right;">North of track</span>									
0900	-X ○	2.5	H	16.0	12.0		00	00	
1000	-X250- ☉	2.5	H	18.0	13.0		34	2.6	3/8 Ci
1100	-X250- ☉	3.0	H	20.0	13.0		33	4.1	3/8 Ci
1200	-X ○	5.0	H	21.0	12.0		34	4.1	
1300	-X ○	5.0	H	22.0	13.0		34	4.1	
1400	-X ○	7.0	H	21.0	13.0		33	5.1	
1500	-X ○	7.0	H	21.0	12.0		32	6.2	
BOURNEMOUTH-HURN (EGHH 038620) 50°47' N 1°50' W Elev. 11 m <span style="float: right;">Southeast of track</span>									
0900	-X ○	4.0	H	17.0	13.0		36	4.6	
1000	-X ○	4.7	H	19.0	13.0		01	4.6	
1100	-X ○	4.7	H	22.0	13.0		01	5.1	
1200	-X ○	5.0	H	24.0	14.0		34	3.6	
1300	-X 50- ☉	4.5	H	23.0	15.0		17	5.1	1/8 Cu
1450	-X250- ☉	4.5	H	24.0	15.0		18	4.6	2/8 Ci
1500	-X 45 ☉	4.0	H	24.0	15.0		19	3.1	1/8 Cu

Table 6.3 (cont.)

## STANDARD METEOROLOGICAL DATA SHEET

Flight No. C-377

Field Site: Yeovil Track

Date: 10 May 1976

Lat. 50°56' N – Long. 2°27' W – El. 60m

Time GCT	Sky and Ceiling (Hundreds of Feet) In Flight		Visibility (Kilometers)	Weather and Obstructions To Vision	Temp. (°C)	Dewpoint (°C)	Rel. Hum. (%)	Wind		Remarks
								Direction (00–36)	Speed (mps)	
0910	120-⊖	250-⊕	8.0	H						1/8 Ac 8/8 Ci
0930	20 ⊖	120-⊖ 250-⊕	8.0	H						1/8 Cu 1/8 Ac 8/8 Ci
1030	20 ⊖	150-⊖ 250-⊖	8.0	H						3/8 Cu 1/8 Ac 7/8 Ci
1110	20 ⊖	250-⊖	8.0	H						2/8 Cu 7/8 Ci
YEOVILTON (EGDY 038530) 51°00' N 2°38' W Elev. 23m										North of track
0900	-X250-⊖		7.0	H	15.0	10.0		32	6.2	4/8 Ci
1000	-X120-⊖	250-⊖	8.0	H	16.0	10.0		32	6.7	1/8 H 1/8 Ac 3/8 Ci
1100	-X120-⊖	250-⊖	8.0	H	17.0	11.0		31	7.7	2/8 H 2/8 Ac 2/8 Ci
1200	25 ⊖	200-⊖	8.0	H	16.0	10.0		31	7.2	1/8 Cu 3/8 Ci
1300	25 ⊖		10.0	H	17.0	8.0		32	9.3	1/8 Cu
1400	25 ⊖		15.0		17.0	6.0		32	10.3	1/8 Cu
1500	25 ⊖		15.0		17.0	6.0		31	10.3	1/8 Cu
BOURNEMOUTH HURN (EGHH 038620) 50°47' N 1°50' W Elev. 11m										Southeast of track
0900	E 30 ⊖	65 ⊖	9.0		15.0	9.0		35	6.2	5/8 Sc 5/8 Ac
1000	30 ⊖		9.0		17.0	8.0		35	7.7	3/8 Sc
1100	35 ⊖		10.0		19.0	9.0		34	3.1	1/8 Cu
1200	35 ⊖		14.0		19.0	9.0		34	7.7	2/8 Cu
1300	38 ⊖	E250 ⊖	14.0		20.0	9.0		32	8.2	2/8 Cu 5/8 Ci
1400	38 ⊖	250 ⊖	13.0		19.0	11.0		34	7.7	3/8 Ci
1500		35 ⊖	14.0		19.0	10.0		30	7.7	2/8 Cu

Table 6.3 (cont.)

## STANDARD METEOROLOGICAL DATA SHEET

Flight No. C-378

Field Site: Rodby Track

Date: 12 May 1976

Lat. 54°41' N – Long. 11°08' E – El. 0m

Time GCT	Sky and Ceiling (Hundreds of Feet)	Visibility (Kilometers)	Weather and Obstructions To Vision	Temp. (°C)	Dewpoint (°C)	Rel. Hum. (%)	Wind		Remarks
							Direction (00–36)	Speed (mps)	
IN FLIGHT									
0950	E 60 ⊕ 90 ⊕	16.0							6/8 Ac
1035	E 60 ⊕ 90 ⊕	19.0							8/8 Ac
1105	55 ⊕ E65 ⊕ 90 ⊕ 250 ⊕	19.0							7/8 Ac
FEHMARNBELT (100060) 54°36' N 11°09' E Elev. 4m <span style="float: right;">South of track</span>									
0900	○	20.0		10.0	8.0		18	7.7	
1200	○			13.0	8.0		16	7.7	
KEGNAES (061190) 54°51' N 9°59' E Elev. 23m <span style="float: right;">West-southwest of track</span>									
0900	E 28 ⊕	12.0		10.0	8.0		18	6.2	5/8 Cu
1200	E 18 ⊕ 45 ⊕	10.0		13.0	9.0		23	9.3	6/8 SE 8/8 As

Table 6.3 (cont.)

STANDARD METEOROLOGICAL DATA SHEET

Flight C-379

Date: 17 May 1976

Field Site: Rodby Track

Lat. 54°41' N – Long. 11°08' E – El. 0m

Time GCT	Sky and Ceiling (Hundreds of Feet)	Visibility (Kilometers)	Weather and Obstructions To Vision	Temp. (°C)	Dewpoint (°C)	Rel. Hum. (%)	Wind		Remarks
							Direction (00 – 36)	Speed (mps)	
FEHMARNBELT (100060) 54°36' N 11°09' E Elev. 4 m <span style="float: right;">South of track</span>									
0900	○	20.0		13.0	9.0		11	2.1	
1200	○	20.0		15.0	11.0		13	3.1	
1500	○	20.0		15.0	10.0		00	00	
KEGNAES (061190) 54°51' N 9°59' E Elev. 23m <span style="float: right;">West-southwest of track</span>									
0900	○	15.0		13.0	10.0		14	2.1	
1200	200 ○	15.0		13.0	10.0		11	5.1	1/8 Ci
1500	200 ○	30.0		13.0	8.0		14	6.2	1/8 Ci

Table 6.3 (cont.)

## STANDARD METEOROLOGICAL DATA SHEET

Flight C-381

Date: 25 May 1976

Field Site: Meppen Track

Lat. 53°00' N – Long. 7°37' E – El. 18m

Time GCT	Sky and Ceiling (Hundreds of Feet)	Visibility (Kilometers)	Weather and Obstructions To Vision	Temp. (°C)	Dewpoint (°C)	Rel. Hum. (%)	Wind		Remarks
							Direction (00–36)	Speed (mps)	
MEPPEN			52°51' N 7°23' E Elev. 19m				South of track		
0900	30 ☉	7.0		15.4		58	10	2.5	1/8 Cu
1000	30 ☉	8.0		16.0		54	09	3.0	2/8 Cu
1100	34 ☉	8.0		17.4		48	13	2.5	2/8 Cu
1200	34 ☉	8.0		17.8		48	13	3.0	4/8 Cu
1300	40 ☉	9.0		18.0		45	13	1.5	4/8 Cu
1400	40 ☉	9.0		17.5		47	11	1.5	3/8 Cu
1500	40 ☉	9.0		17.6		44	09	3.0	3/8 Cu

Table 6.3 (cont.)

## STANDARD METEOROLOGICAL DATA SHEET

Flight No. C-382  
Date: 26 May 1976

Field Site: Meppen Track  
Lat. 53°00' N – Long. 7°37' E – El. 18 m

Time GCT	Sky and Ceiling (Hundreds of Feet)	Visibility (Kilometers)	Weather and Obstructions To Vision	Temp. (°C)	Dewpoint (°C)	Rel. Hum. (%)	Wind		Remarks
							Direction (00–36)	Speed (mps)	
IN FLIGHT									
0930	25 ☉ E250 ☉	8.0	HK						1/8 Cu 7/8 Ci
OLDENBURG (EDNO 102150) 53°11' N 8°10' E Elev. 12 m East of track									
1044	30 ☉ E 50 ☉	11.2		15.0	6.0		27	4.6	3/8 Cu 7/8 Sc
1144	30 ☉ E 50 ☉	11.2		16.0	5.0		26	5.6	2/8 Cu 5/8 Sc
1244	20 ☉ E 35 ☉			11.0	8.0		22	3.0	1/8 Cb 7/8 Sc RWB04 E32
AHLHORN (EDNA 10218) 52°53' N 8°14' E Elev. 48 m South of track									
0944	25 ☉ 250–☉	11.2		15.0	7.0		25	5.6	3/8 Cu 4/8 Ci
1044	35 ☉ 50 ☉	11.2		15.0	5.0		25	6.1	2/8 Cu 3/8 Sc
1144	E 30 ☉ 50 ☉	8.0	TRW	15.0	5.0		28	5.6	5/8 Cb 3/8 Sc
1207	18 ☉ E 30 ☉	2.0	TRW				27	9.2	2/8 Cu 7/8 Cb
1223	18 ☉ E 30 ☉	5.0	TRW				27	5.6	1/8 Cu 7/8 Cb
1244	30 ☉			20.0	8.0		27	5.6	2/8 Cb
LINGEN (103050) 52°31' N 7°19' E Elev. 21 m Southeast of track									
0900	25 ☉	16.0		15.0	6.0		23	7.2	4/8 Cu
1000	MSG								
1100	23 ☉ E 27 ☉	5.0	TRW	11.0	8.0		26	8.7	1/8 Cu 7/8 Cb
1200	27 ☉ E 30 ☉	5.0		10.0	8.0		23	4.6	1/8 Cu 6/8 Cb
1300	27 ☉ 30 ☉	20.0		10.0	9.0		22	4.6	2/8 Cu 4/8 Cb

There were intermittent rain showers here during the period.

Table 6.3 (cont.)

## STANDARD METEOROLOGICAL DATA SHEET

Flight No. C-382  
Date: 26 May 1976

Field Site: Meppen Track  
Lat. 53°00' N – Long. 7°37' E – El. 18m

Time GCT	Sky and Ceiling (Hundreds of Feet)		Visibility (Kilometers)	Weather and Obstructions To Vision	Temp. (°C)	Dewpoint (°C)	Rel. Hum. (%)	Wind		Remarks
								Direction (00 – 36)	Speed (mps)	
MEPPEN (10304) 52°5' N 7°23' E Elev. 19m								South of track		
0800	20 ☉	180 ☉	6.0		13.3		71	24	5.0	2/8 Cu 1/8 As
0900	25 ☉		8.0		14.5		60	24	5.0	4/8 Cu
1000	20 ☉	E 50 ☉	8.0		13.6		61	25	4.0	3/8 Cu 6/8 Sc
1100	20 ☉	E 50 ☉	2.5	RW	9.0		86	25	5.0	3/8 Cu 7/8 Sc
1200	20 ☉	E 50 ☉	11.0	RW-	10.5		84	21	4.5	3/8 Cu 6/8 Sc

## 7. DATA PRESENTATION

### 7.1 AIRBORNE DATA AND FLIGHT SUMMARY

Between 7 April and 26 May 1976, thirteen flights were made in northern Germany. Eight of these flights contain useable data profiles. Selected data for these flights are reported herein.

The eight flights were conducted in northern Europe on four flight tracks in Denmark, England, Germany, and Netherlands (see Fig. 1-1). The latitude, longitude, and altitude of each flight track are given in Table 7.1. The terrain beneath three of the flight tracks was low lying and flat, mostly cultivated farmlands. The flight track in Denmark was mostly over water.

The ground station operated from 8 April to 25 May 1976 near the flight tracks in Germany and the Netherlands. Its location and dates of operation are also noted in Table 7.1.

#### PHOTOGRAPHIC DOCUMENTATION

Sky and terrain conditions encountered during the data flights were documented photographically during each straight and level flight sequence, at each of several designated altitudes, in conjunction with the radiometric measurements made in each spectral filter. On sunlit days the documentary photographs were taken simultaneously with the measurements made by the upper hemisphere scanner in the sun mode. On over-

**Table 7.1**

LOCATION AND GROUND ELEVATION OF FLIGHT TRACKS AND GROUND SITES

Field Site	Latitude	Longitude	Approx. Ground Elevation (m)	1976 Dates of Operation	Flight No.
<b>FLIGHT TRACK</b>					
Yeovil, England	50°56' N	2°27' W	60	May 1, 8, 10	C-373, C-376, C-377
Soesterberg, Netherlands	51°56' N	5°35' E	6	April 12	C-372
Meppen, Germany	53°00' N	7°37' E	18	May 25, 26	C-381, C-382
Rodby, Denmark	54°41' N	11°08' E	0	May 12, 17	C-378, C-379
<b>GROUND STATION</b>					
Soesterberg, Netherlands	52°08' N	5°17' E		April 12, 20	
Meppen, Germany	52°52' N	7°23' E		April 8, 9 May 20, 24, 25	

cast days the photographs were taken simultaneously with the measurements of sky and terrain radiance. One should be aware that while the photographs are instantaneous, the data measurements require a four-minute interval for completion. In four minutes the aircraft travels approximately ten miles.

The photographs illustrating sky and terrain conditions during each of the eight flights have been examined and classified with respect to discernible cloud conditions. A summary of these general cloud and terrain descriptions is presented in Table 7.2.

**Table 7.2**

**SUMMARY OF HEMISPHERICAL PICTURES**

**LOWER HEMISPHERE\***

Flight No.	Filter	~ 300 m	~ 1500 m	~ 3000 m	~ 6000 m
C-372	2,3	Broken shadow, brown and green fields	Haze, fields	Haze, broken clouds, fields	Haze, scattered clouds
	4,5	Scattered shadow, fields	Haze, fields	—	Haze, scattered to broken shadow on ground, fields
C-373	2,3	Haze, fields	Haze, fields	Haze, fields	Nearly opaque haze
	4,5	Clear, fields	Haze, fields	Haze, fields	Opaque haze
C-376	2,3	Haze, fields	Haze, fields	Nearly opaque haze	Opaque haze
	4,5	Haze, grass, town	Nearly opaque haze	Nearly opaque haze	Nearly opaque haze, clouds?
C-377	2,3	Haze, patchy vegetation	Haze, patchy vegetation	Haze, scattered clouds	Haze, scattered clouds
	4,5	Haze, fields, woods	Haze, scattered clouds, patchy terrain	Haze, broken to scattered clouds	Haze, broken to scattered clouds
C-378	2,3	Clear, water	Clear except for 1 wisp water	—	
	4,5	Clear, water	Clear, water	—	
C-379	2,3	Clear, water	Clear, water and shore	Clear, water and shore	Clear, water and shore
	4,5	Clear, water	Clear, water and shore	Clear, water and shore	Clear, water and shore
C-381	2,4	Scattered shadows, fields	Nearly opaque haze, some scattered clouds	Nearly opaque haze, scattered clouds	Nearly opaque haze, scattered to broken clouds
	3,5	Scattered to broken shadow, fields and dirt	—	Nearly opaque haze, broken to scattered clouds	Nearly opaque haze, broken clouds
C-382	2,4	Mostly shadow, fields	—	Broken cloud deck and haze	Nearly solid cloud deck

\* In lower hemisphere, the term "clear" means there are no distinct, well-defined cloud shadows.

The cloud conditions for the eight OPAQUE I flights appear to fall into three general categories, one, cloud free at all altitudes; two, clouds at low altitudes only; and three, fully overcast or cloudy at all flight altitudes.

Photographs illustrating typical sky and terrain conditions during four of the flights reported herein are shown in Figs. 7-1 and 7-2. In each instance, the picture on the left represents the sky (upper hemisphere) as seen through a 180-degree lens, and the picture on the right represents the terrain (lower

**Table 7.2**

SUMMARY OF HEMISPHERICAL PICTURES

UPPER HEMISPHERE

Flight No.	Filter	~ 300 m	~ 1500 m	~ 3000 m**	~ 6000 m**
C-372	2,3	Scattered clouds, sun obscured	Scattered clouds, sun partially obscured	Clear	Clear
	4,5	Scattered clouds, sun clear	Scattered clouds, sun clear	—	Clear
C-373	2,3	Thin wispy overcast with blue visible	Thin overcast	Overcast	Overcast
	4,5	Overcast	Overcast	Overcast	Overcast
C-376	2,3	Haze	Haze	Clear	Clear
	4,5	Haze	Haze	Clear	Clear
C-377	2,3	Haze, wispy clouds	Haze, wispy clouds	Haze, wispy clouds on horizon?	Clear?
	4,5	Haze, scattered clouds, sun clear?	Haze, wispy clouds	Thin clouds?	Thin clouds?
C-378	2,3	Thin overcast	Thin overcast to scattered wispy clouds	—	—
	4,5	Thin overcast with wispy transparent clouds	Thin, wispy overcast	—	—
C-379	2,3	Clear	Clear	Clear	Clear
	4,5	Clear	Clear	Clear	Clear
C-381	2,4	Scattered clouds	Clear	Clear	Clear
	3,5	Scattered clouds	—	Clear	Cloud wisps changing to clear, sun clear
C-382	2,4	Broken clouds, sun obscured	—	Clear	Clear

\*\* Camera housing window was unheated and subject to frosting at high altitude making it difficult to distinguish a clear sky from one with wisps of cloud.



**FLIGHT C-372  
Soesterberg Track**

Upper and Lower Hemisphere  
294m AGL 1140 GMT

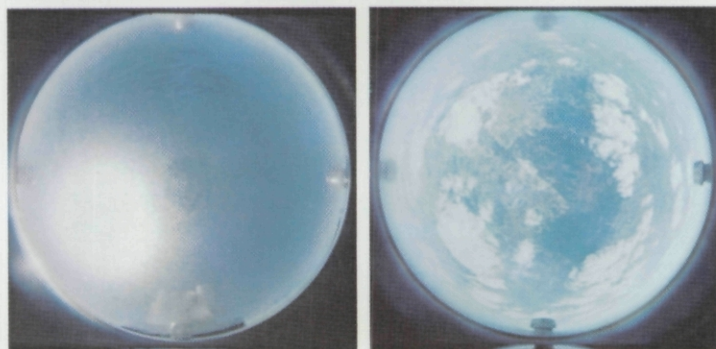

Upper and Lower Hemisphere  
5771 m AGL 1321 GMT

Fig. 7-1. Typical Sky and Terrain Photographs for Flights C-372 and C-373.

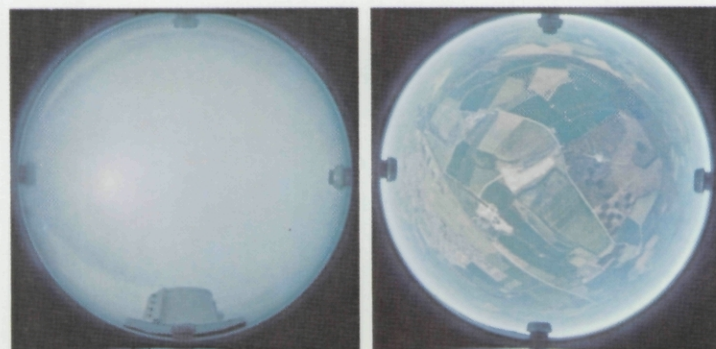

**FLIGHT C-373  
Yeovil Track**

Upper and Lower Hemisphere  
581 m AGL 1254 GMT

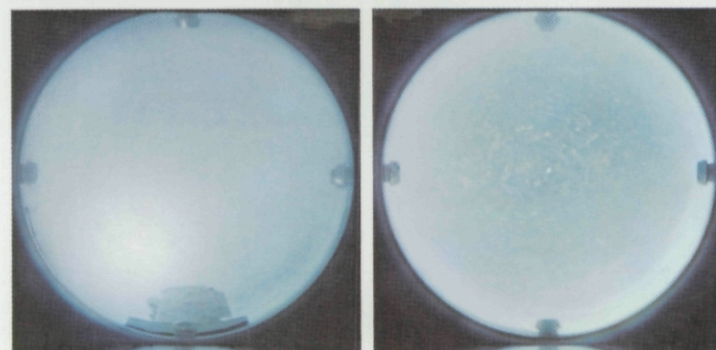

Upper and Lower Hemisphere  
5837m AGL 1420 GMT

**FLIGHT C-379**  
**Rodby Track**

Upper and Lower Hemisphere  
282m AGL 1143 GMT

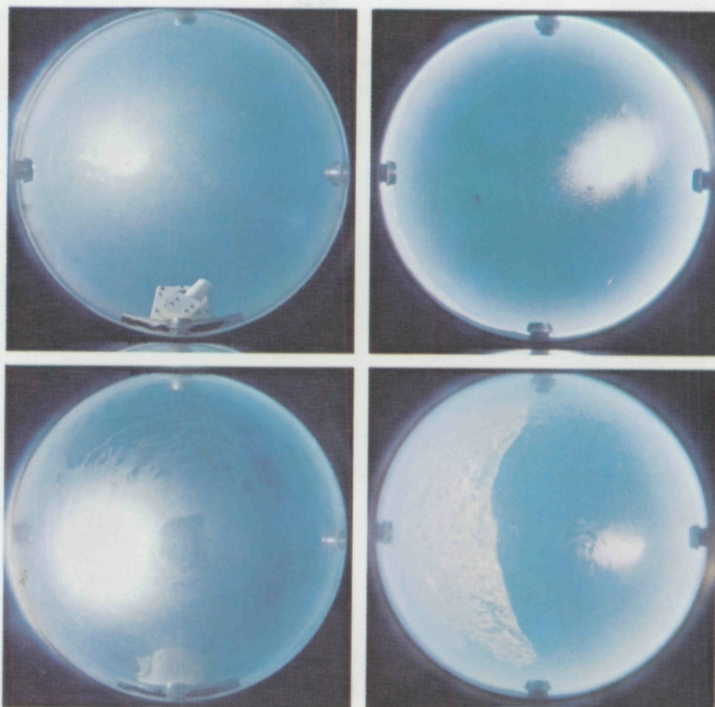

Upper and Lower Hemisphere  
6265m AGL 1304 GMT

Fig. 7-2. Typical Sky and Terrain Photographs for Flights C-379 and C-381.

**FLIGHT C-381**  
**Meppen Track**

Upper and Lower Hemisphere  
266m AGL 1103 GMT

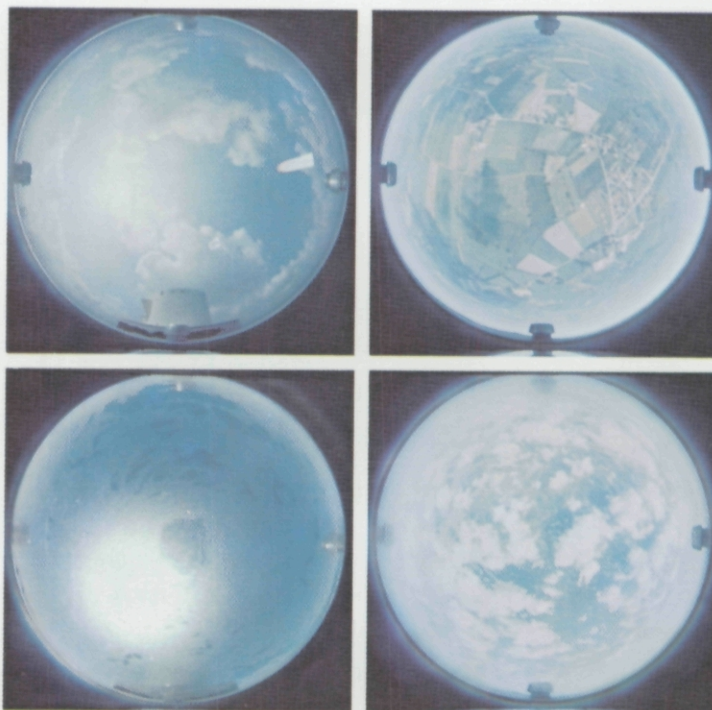

Upper and Lower Hemisphere  
5492m AGL 1223 GMT

hemisphere). The photographs were selected to represent the conditions encountered at both the highest and lowest flight altitudes during each of the four flights.

The pictures representing Flight C-379, Fig. 7-2, illustrate the cloud free conditions of category one, and the Rodby flight track which was mostly over water in the Femer Bay south of Lolland, Denmark.

The pictures representing Flight C-372, Fig. 7-1, and C-381, Fig. 7-2, illustrate the low altitude cloud conditions of category two. Flight C-372 was over the Soesterberg track in the Netherlands and Flight C-381 was over the Meppen track in Germany, however, both tracks are over heavily cultivated flat farmlands.

The pictures representing Flight C-373, Fig. 7-1, illustrate the full overcast conditions of category three. Flight C-373 was over the Yeovil track in southern England. The underlying terrain was again mostly cultivated farmlands.

## RADIOMETRIC DOCUMENTATION

Table 7.3 contains a summary of pertinent descriptive information on the eight flights for which Radiometric data are reported herein. The flight numbers are sequential. The times under the total time of data-taking column are Greenwich Mean Time (GMT) and Local Civil Time (LCT). They are abstracted from program FLTDOC listings for each flight. The LCT is equal to GMT+1. The sun zenith angles are tabulated for the time when sky radiance data-taking began, at the time of sun transit (minimum sun zenith angle), and at the conclusion of the last descent. The maximum and minimum flight altitudes are noted in column 12.

The total volume scattering coefficient, equivalent attenuation length and beam transmittance data are presented both tabularly and graphically in Section 7.3. The downwelling irradiance data are presented graphically only. All of the data are grouped into sets by flight number. A detailed description and report of the existing weather conditions are given as the introductory page to each data set.

## 7.2 DESCRIPTION OF AIRBORNE DATA TABLES AND GRAPHS

### DATA TABLES

Data are presented in tables of:

Total Volume Scattering Coefficient

Equivalent Attenuation Length

Beam Transmittance Between Ground and Altitude

Each optical property is tabulated in the tables as a function of altitude above ground level. The data are further divided by optical filters which are given in order of increasing wavelength.

The tables have been divided into two categories depending upon the meaning of the altitude in the tables. First is the variable tabulated by measurement altitude: total volume scattering coefficient.

Second are the variables tabulated by object or sensor altitude depending on whether the path of sight is upward or downward: equivalent attenuation length, and beam transmittance.

CATEGORY I: MEASUREMENT ALTITUDE

*Total Volume Scattering Coefficient.* The total volume scattering coefficient  $s(z)$  is tabulated by measurement altitude in two to four columns for the optical filters. The altitude is given in meters, above ground level, at 30 meters (98.4 foot) increments. The measurement unit for the total scattering coefficient is "m<sup>-1</sup>." The extrapolated points above or below the actual altitudes of measurement are indicated by parentheses.

At the bottom of the total scattering coefficient table are given the first and last data altitudes. This is the lowest and highest altitude of airborne data measurements.

The total scattering coefficient is used for the calculation of atmospheric beam transmittance and equivalent attenuation length in the ensuing tables using the equations of the Theory, Section 2.

Table 7.3

FLIGHT DATA SUMMARY

Flight No.	Date (1976)	Flight Track	Total Time of Data Taking				Filter	Sun Zenith Angle (degrees)			Max. - Min. Flight Altitude meters (AGL)
			Start of First ST&LV		End of Last VPRO			Start	Transit	End	
			GMT	LCT	GMT	LCT					
C-372	12 Apr.	Soesterberg	1141	1241	1343	1443	2,3	43.1	-	50.2	5760 - 270
			1347	1447	1538	1638	4,5	50.4	-	64.9	5760 - 270
C-373	1 May	Yeovil	1056	1156	1250	1350	2,3	38.5	35.7	36.8	5910 - 570
			1255	1355	1446	1546	4,5	37.0	-	48.1	5880 - 570
C-376	8 May	Yeovil	0900	1000	1047	1147	2,3	50.0	-	37.2	6060 - 540
			1053	1153	1240	1340	4,5	36.8	33.7	34.5	6120 - 510
C-377	10 May	Yeovil	0904	1004	1100	1200	2,3	48.9	-	35.6	6090 - 360
			1109	1209	1253	1353	4,5	35.1	33.2	34.6	6090 - 360
C-378	12 May	Rodby	0944	1044	1025	1125	2,3	40.1	-	37.5	1800 - 270
			1032	1132	1118	1218	4,5	37.2	36.5	36.5	1590 - 270
C-379	17 May	Rodby	0957	1057	1138	1238	2,3	38.0	35.3	35.7	6270 - 300
			1143	1243	1332	1432	4,5	35.8	-	44.3	6270 - 270
C-381	25 May	Meppen	1058	1158	1241	1341	2,4	32.4	32.0	35.1	5490 - 270
			1246	1346	1416	1516	3,5	35.5	-	45.6	5460 - 270
C-382	26 May	Meppen	0925	1025	1056	1156	2,4	39.4	-	32.3	5430 - 330

## CATEGORY II: OBJECT OR SENSOR ALTITUDE

These variables are tabulated by object or sensor altitude depending upon whether the path of sight is upward or downward. For upward paths of sight  $\theta < 90^\circ$  the sensor is at ground level and the altitudes shown in the table are the object altitudes. For the downward paths of sight  $\theta > 90^\circ$ , the object is at ground level and the altitudes in the table are the sensor altitudes.

*Equivalent Attenuation Length.* The equivalent attenuation length  $\bar{L}(z)$  is a pseudo-attenuation length which, when combined with its altitude  $z$ , can be used directly in Eq. 2.6 to compute beam transmittance. The equivalent attenuation length permits easy calculation of the atmospheric beam transmittance between ground level and altitude  $z$  above ground level for any downward path of sight from  $95^\circ$  to  $180^\circ$  in zenith angle or between altitude and ground level for any upward path of sight from  $0^\circ$  to  $85^\circ$  in zenith angle.

The equivalent attenuation length  $\bar{L}(z)$  is tabulated by altitude for the path of sight between ground and the altitude shown in two to four columns for the optical filters. The altitude is given in meters, above ground level, at 300-meter (984 foot) increments. The unit for the equivalent attenuation length is "m."

*Beam Transmittance Between Ground and Altitude.* The atmospheric beam transmittance is tabulated for the vertically upward path of sight  $T_z(0,0^\circ)$  or the vertically downward path of sight  $T_z(z,180^\circ)$  for the path of sight between ground and the altitude shown. The beam transmittance is computed from measurements of total scattering coefficient. The assumption is made that there is no significant atmospheric absorption in the pass bands of the measurements, whence the atmospheric attenuation coefficient  $\alpha(z)$  is assumed equivalent to the scattering coefficient  $s(z)$ .

The vertical beam transmittance is tabulated by altitude for the path of sight between ground and the altitude shown in two to four columns for the optical filters. The altitude is given in meters, above ground level, at 300-meter (984-foot) increments. This property is dimensionless.

## DATA GRAPHS

Data are also presented in graphs of:

- Total Volume Scattering Coefficient
- Equivalent Attenuation Length, Between Ground and Altitude
- Vertical Beam Transmittance, Between Ground and Altitude
- Downwelling Irradiance

*Total Volume Scattering Coefficient.* The total volume scattering coefficient  $s(z)$  in  $m^{-1}$  is graphed using a single average value for each 30-meter altitude interval. Identifying symbols for the spectral filters appear every fifth data point, or at 150-meter intervals. These same data were tabulated in the total scattering coefficient table. The extrapolated values are indicated by a dashed line.

*Equivalent Attenuation Length.* The equivalent attenuation length  $\bar{L}(z)$  in meters, for the path between ground and altitude, is graphed for each 30-meter altitude interval. This represents smaller altitude increments than in the tabular display of equivalent attenuation length. Spectral identifying symbols appear at 150-meter intervals or every fifth data point.

*Vertical Beam Transmittance Between Ground and Altitude.* The vertical beam transmittance  $T_p(0,0^\circ)$  or  $T_p(z,180^\circ)$  between ground and altitude is graphed for each 30-meter altitude interval. This represents smaller altitude increments than in the tabular display of beam transmittance. Spectral identifying symbols appear at 150-meter intervals or every fifth data point.

*Downwelling Irradiance.* The downwelling irradiance  $H(z,d)$  is graphed as a function of altitude above ground level (AGL). These irradiances were measured by the dual irradiator concurrently with the total volume scattering coefficient measurements. The downwelling irradiance during the ascent or descent is graphed using a single average value for each 30-meter altitude interval and the identifying symbol for the spectral filter appears every fifth data point; thus when data are continuous the symbols appear at 150-meter intervals. The second symbol for each filter designates the average value measured during each three-minute straight and level flight element.

### 7.3 PRESENTATION OF AIRBORNE DATA

Tabular listings and graphical displays of the data discussed in Section 7.2 are presented in the pages immediately following. Users should be aware that regardless of the display format, the data values are valid to, at best, only three significant figures. The tables of beam transmittance, in particular, should be rounded off to 2 digits prior to further application.

It should also be remembered that all values in the data tables except scattering coefficient are computed values based upon the measured values of scattering coefficient.

All altitudes presented in the data tables, in the flight description, and in the graphs are given as above ground level (AGL) unless otherwise specified.

FLIGHT C-372 – 12 APRIL 1976 – DESCRIPTION OF FLIGHT AND WEATHER CHARACTERISTICS

Filter Identification	Date Interval			Solar Zenith Angle			Maximum Flight Altitude (meters)	Average Terrain Elevation (meters)
	Start (GMT)	End (GMT)	Elapsed (hrs)	Initial ST & LV (degrees)	Solar Transit (degrees)	Final VPRO (degrees)		
2 and 3	1141	1343	2.0	43.1	—	50.2	5760	6
4 and 5	1347	1538	1.9	50.4	—	64.9	5760	6

Flight C-372 was an afternoon flight. There were scattered low altitude clouds.

The approximate east-west track was located between Deelen and DeBilt, in central Netherlands. Typical terrain features were brown and green fields interspersed with occasional small towns.

The in-flight observer reported significantly heavier haze at the western end of the flight track.

Data from Soesterberg, 30 kilometers northwest of the track center point, indicate varying amounts of stratocumulus clouds at 1500 meters (5000 feet). Sky cover varied from one to three eighths. Visibility of 11 kilometers at 1200 GMT improved to 25 kilometers at 1500 GMT.

Deelen, 24 kilometers northeast of the track center point, also reported cloud amounts varying from one to three eighths with bases of 900 meters (3000 feet) at 1200 GMT raising to 1500 meters (5000 feet) at 1600 GMT. Visibility was reported as 18 to 20 kilometers.

The radiosonde station at DeBilt was 33 kilometers northwest and upstream from the flight track center point.

The surface charts show a dissipating stationary front extending southsouthwest from Scandinavia to central Spain. The center of the Atlantic High was located southwest of the Azores. At 500 millibars the Denmark-Germany area was in a col with light easterly winds. The airmass was stable continental polar.

# FLIGHT NO. C-372

## SOESTERBERG

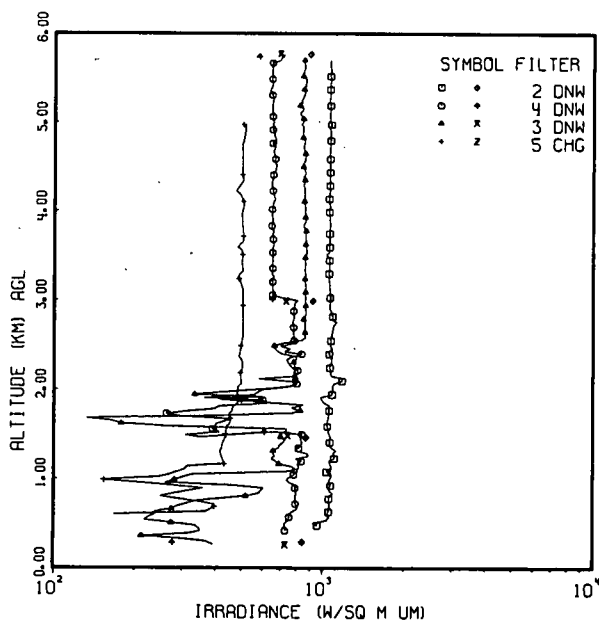
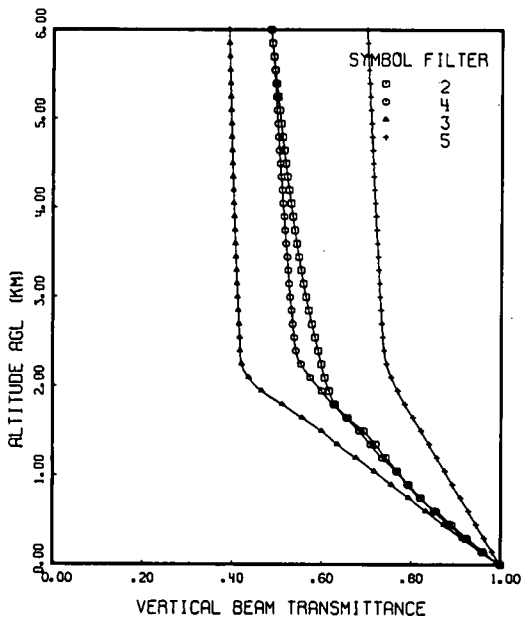
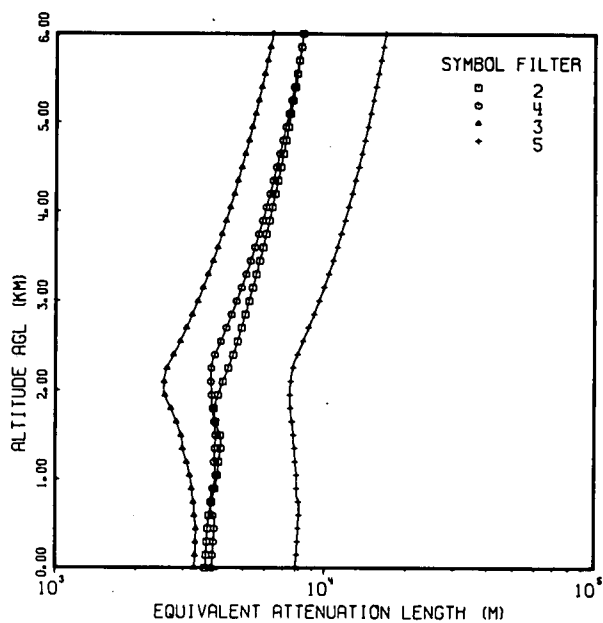
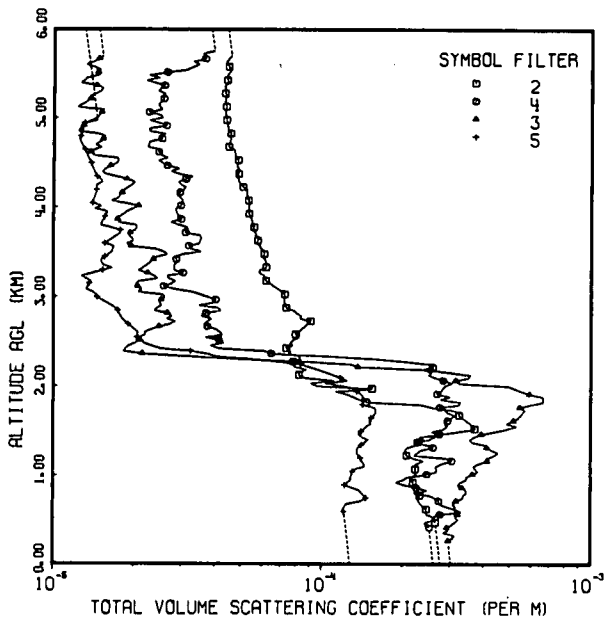

**FLIGHT NO. C-372**  
**TOTAL VOLUME SCATTERING COEFFICIENT**

(JOB 2243 DATE 03/09/77)  
 DATE 41276 FLIGHT NO. C-372 GROUND LEVEL ALTITUDE (M)= 6

ALTITUDE (M)	TOTAL VOLUME SCATTERING COEFFICIENT (PER M)			
	FILTERS	2	4	3
0	(2.77E-04 )	(2.62E-04 )	(3.04E-04 )	(1.28E-04 )
30	(2.75E-04 )	(2.60E-04 )	(3.03E-04 )	(1.27E-04 )
60	(2.75E-04 )	(2.60E-04 )	(3.02E-04 )	(1.27E-04 )
90	(2.74E-04 )	(2.59E-04 )	(3.01E-04 )	(1.27E-04 )
120	(2.73E-04 )	(2.58E-04 )	(3.00E-04 )	(1.26E-04 )
150	(2.73E-04 )	(2.58E-04 )	(3.00E-04 )	(1.26E-04 )
180	(2.72E-04 )	(2.57E-04 )	(2.99E-04 )	(1.26E-04 )
210	(2.71E-04 )	(2.56E-04 )	(2.98E-04 )	(1.25E-04 )
240	(2.71E-04 )	(2.56E-04 )	(2.97E-04 )	(1.25E-04 )
270	(2.70E-04 )	(2.55E-04 )	2.96E-04	(1.25E-04 )
300	(2.69E-04 )	(2.54E-04 )	3.07E-04	(1.24E-04 )
330	(2.68E-04 )	(2.54E-04 )	3.13E-04	(1.24E-04 )
360	(2.68E-04 )	(2.53E-04 )	2.83E-04	(1.24E-04 )
390	(2.67E-04 )	(2.52E-04 )	2.96E-04	(1.23E-04 )
420	(2.66E-04 )	2.52E-04	2.92E-04	(1.23E-04 )
450	(2.66E-04 )	2.43E-04	3.04E-04	(1.23E-04 )
480	2.65E-04	2.42E-04	3.12E-04	(1.22E-04 )
510	2.67E-04	2.67E-04	3.23E-04	(1.22E-04 )
540	2.61E-04	2.59E-04	3.13E-04	(1.22E-04 )
570	2.45E-04	2.76E-04	3.21E-04	(1.21E-04 )
600	2.45E-04	3.31E-04	3.21E-04	1.21E-04
630	2.45E-04	3.13E-04	3.09E-04	1.20E-04
660	2.37E-04	2.88E-04	3.15E-04	1.22E-04
690	2.33E-04	2.73E-04	3.07E-04	1.24E-04
720	2.29E-04	2.72E-04	3.16E-04	1.40E-04
750	2.27E-04	2.65E-04	3.35E-04	1.46E-04
780	2.31E-04	2.51E-04	3.35E-04	1.43E-04
810	2.25E-04	2.20E-04	3.45E-04	1.41E-04
840	2.21E-04	2.47E-04	3.45E-04	1.38E-04
870	2.19E-04	2.25E-04	3.33E-04	1.30E-04
900	2.17E-04	2.03E-04	3.21E-04	1.21E-04
930	2.19E-04	1.88E-04	3.27E-04	1.25E-04
960	2.13E-04	2.00E-04	3.45E-04	1.28E-04
990	2.16E-04	2.09E-04	3.45E-04	1.28E-04
1020	2.25E-04	2.46E-04	3.63E-04	1.29E-04
1050	2.22E-04	2.67E-04	3.81E-04	1.30E-04
1080	2.22E-04	2.67E-04	3.72E-04	1.31E-04
1110	2.23E-04	2.65E-04	3.66E-04	1.45E-04
1140	2.24E-04	2.80E-04	3.84E-04	1.43E-04
1170	2.39E-04	3.04E-04	4.12E-04	1.41E-04
1200	2.17E-04	2.95E-04	4.14E-04	1.39E-04
1230	2.06E-04	2.20E-04	4.36E-04	1.37E-04
1260	2.05E-04	2.27E-04	4.54E-04	1.35E-04
1290	2.03E-04	2.34E-04	4.30E-04	1.35E-04
1320	2.08E-04	2.59E-04	4.10E-04	1.36E-04
1350	2.27E-04	2.44E-04	4.02E-04	1.40E-04
1380	2.27E-04	2.21E-04	3.61E-04	1.45E-04
1410	2.51E-04	2.40E-04	3.55E-04	1.49E-04
1440	2.61E-04	2.31E-04	3.68E-04	1.41E-04
1470	2.72E-04	2.74E-04	3.91E-04	1.37E-04
1500	3.21E-04	2.56E-04	4.40E-04	1.40E-04

**FLIGHT NO. C-372**  
**TOTAL VOLUME SCATTERING COEFFICIENT**

(JOB 2243 DATE 03/C9/77)  
 DATE 41276 FLIGHT NO. C-372 GROUND LEVEL ALTITUDE (M)= 6

ALTITUDE (M)	TOTAL VOLUME SCATTERING COEFFICIENT (PER M)			
	FILTERS	2	4	3
1530	3.70E-04	2.82E-04	4.86E-04	1.43E-04
1560	3.61E-04	2.93E-04	5.30E-04	1.47E-04
1590	3.56E-04	2.85E-04	4.85E-04	1.52E-04
1620	3.45E-04	2.94E-04	5.15E-04	1.49E-04
1650	3.33E-04	3.03E-04	5.36E-04	1.53E-04
1680	3.24E-04	3.12E-04	5.48E-04	1.56E-04
1710	3.26E-04	2.93E-04	5.56E-04	1.59E-04
1740	3.02E-04	2.88E-04	5.70E-04	1.58E-04
1770	2.54E-04	2.74E-04	5.43E-04	1.57E-04
1800	2.33E-04	3.25E-04	5.92E-04	1.41E-04
1830	1.46E-04	3.27E-04	6.65E-04	1.41E-04
1860	1.37E-04	2.76E-04	6.65E-04	1.42E-04
1890	1.30E-04	3.00E-04	6.66E-04	1.42E-04
1920	1.23E-04	2.67E-04	5.92E-04	1.40E-04
1950	1.12E-04	2.77E-04	5.55E-04	1.34E-04
1980	1.54E-04	2.82E-04	5.23E-04	1.35E-04
2010	9.51E-05	2.86E-04	4.92E-04	1.19E-04
2040	9.06E-05	3.06E-04	3.22E-04	1.03E-04
2070	1.10E-04	2.82E-04	3.15E-04	1.24E-04
2100	8.55E-05	2.64E-04	3.52E-04	1.17E-04
2130	8.18E-05	2.49E-04	3.56E-04	1.10E-04
2160	8.24E-05	2.57E-04	2.98E-04	1.03E-04
2190	8.73E-05	2.37E-04	2.44E-04	9.61E-05
2220	7.88E-05	2.58E-04	1.36E-04	8.92E-05
2250	7.71E-05	2.54E-04	1.27E-04	8.29E-05
2280	7.81E-05	2.06E-04	8.77E-05	6.87E-05
2310	8.32E-05	1.58E-04	4.85E-05	5.44E-05
2340	8.15E-05	1.08E-04	3.21E-05	4.02E-05
2370	7.49E-05	6.46E-05	2.15E-05	3.72E-05
2400	7.64E-05	6.11E-05	1.82E-05	3.23E-05
2430	7.34E-05	4.11E-05	1.86E-05	2.48E-05
2460	7.76E-05	3.83E-05	1.90E-05	2.32E-05
2490	7.58E-05	4.31E-05	2.02E-05	2.16E-05
2520	7.81E-05	4.13E-05	2.09E-05	2.14E-05
2550	8.20E-05	3.67E-05	2.08E-05	2.04E-05
2580	7.96E-05	4.24E-05	2.20E-05	2.05E-05
2610	8.18E-05	4.18E-05	2.18E-05	2.07E-05
2640	8.39E-05	4.01E-05	2.32E-05	2.00E-05
2670	8.61E-05	3.73E-05	2.47E-05	1.95E-05
2700	8.83E-05	3.63E-05	2.72E-05	1.90E-05
2730	9.04E-05	3.76E-05	2.85E-05	1.84E-05
2760	8.28E-05	3.88E-05	2.64E-05	1.81E-05
2790	8.35E-05	3.54E-05	2.76E-05	1.78E-05
2820	8.02E-05	3.69E-05	2.66E-05	1.76E-05
2850	7.82E-05	4.20E-05	2.36E-05	1.73E-05
2880	7.33E-05	4.07E-05	2.44E-05	1.71E-05
2910	7.25E-05	3.48E-05	2.52E-05	1.65E-05
2940	7.23E-05	3.97E-05	2.48E-05	1.58E-05
2970	7.21E-05	4.02E-05	2.52E-05	1.52E-05
3000	7.22E-05	3.76E-05	2.61E-05	1.45E-05

**FLIGHT NO. C-372**  
**TOTAL VOLUME SCATTERING COEFFICIENT**

(JOB 2243 DATE 03/09/77)  
 DATE 41276 FLIGHT NO. C-372 GROUND LEVEL ALTITUDE (M)= 6

ALTITUDE (M)	FILTERS	TOTAL VOLUME SCATTERING COEFFICIENT (PER M)			
		2	4	3	5
3030	7.24E-05	3.51E-05	2.54E-05	1.44E-05	
3060	7.02E-05	3.27E-05	2.07E-05	1.40E-05	
3090	6.81E-05	2.82E-05	2.14E-05	1.32E-05	
3120	6.60E-05	2.57E-05	2.06E-05	1.34E-05	
3150	6.38E-05	2.74E-05	2.03E-05	1.36E-05	
3180	6.17E-05	2.85E-05	2.08E-05	1.38E-05	
3210	6.09E-05	2.68E-05	2.44E-05	1.33E-05	
3240	6.08E-05	2.65E-05	2.38E-05	1.26E-05	
3270	5.80E-05	3.04E-05	2.24E-05	1.40E-05	
3300	5.86E-05	2.82E-05	2.07E-05	1.53E-05	
3330	6.18E-05	2.81E-05	2.16E-05	1.66E-05	
3360	6.18E-05	2.81E-05	2.22E-05	1.54E-05	
3390	6.17E-05	2.89E-05	2.29E-05	1.52E-05	
3420	6.12E-05	2.86E-05	2.36E-05	1.50E-05	
3450	6.00E-05	2.83E-05	2.42E-05	1.55E-05	
3480	6.08E-05	3.02E-05	2.66E-05	1.61E-05	
3510	6.12E-05	3.54E-05	2.56E-05	1.66E-05	
3540	5.89E-05	3.23E-05	2.41E-05	1.66E-05	
3570	5.85E-05	3.18E-05	1.95E-05	1.68E-05	
3600	5.69E-05	3.49E-05	1.87E-05	1.55E-05	
3630	5.75E-05	3.51E-05	1.98E-05	1.61E-05	
3660	5.85E-05	3.55E-05	1.96E-05	1.66E-05	
3690	5.61E-05	3.52E-05	1.91E-05	1.72E-05	
3720	5.66E-05	3.09E-05	1.93E-05	1.77E-05	
3750	5.49E-05	3.14E-05	2.01E-05	1.78E-05	
3780	5.56E-05	3.16E-05	2.05E-05	1.64E-05	
3810	5.45E-05	2.94E-05	2.03E-05	1.50E-05	
3840	5.48E-05	2.73E-05	1.75E-05	1.52E-05	
3870	5.43E-05	2.98E-05	1.73E-05	1.54E-05	
3900	5.38E-05	2.94E-05	1.76E-05	1.56E-05	
3930	5.32E-05	2.89E-05	1.83E-05	1.58E-05	
3960	5.32E-05	2.86E-05	1.87E-05	1.59E-05	
3990	5.32E-05	2.84E-05	1.97E-05	1.42E-05	
4020	5.30E-05	2.97E-05	2.08E-05	1.51E-05	
4050	5.41E-05	3.00E-05	1.86E-05	1.40E-05	
4080	5.30E-05	3.03E-05	1.65E-05	1.41E-05	
4110	5.24E-05	2.97E-05	1.74E-05	1.42E-05	
4140	5.24E-05	2.87E-05	1.77E-05	1.43E-05	
4170	5.23E-05	2.96E-05	1.80E-05	1.44E-05	
4200	5.25E-05	3.04E-05	1.83E-05	1.44E-05	
4230	5.05E-05	3.10E-05	1.89E-05	1.45E-05	
4260	5.00E-05	2.96E-05	1.96E-05	1.45E-05	
4290	4.86E-05	2.91E-05	2.01E-05	1.52E-05	
4320	4.88E-05	3.10E-05	1.87E-05	1.50E-05	
4350	4.77E-05	3.29E-05	1.73E-05	1.45E-05	
4380	4.87E-05	2.92E-05	1.56E-05	1.44E-05	
4410	4.77E-05	2.73E-05	1.52E-05	1.42E-05	
4440	4.88E-05	2.93E-05	1.57E-05	1.41E-05	
4470	4.80E-05	2.64E-05	1.63E-05	1.39E-05	
4500	4.83E-05	2.54E-05	1.72E-05	1.38E-05	

# FLIGHT NO. C-372

## TOTAL VOLUME SCATTERING COEFFICIENT

(JOB 2243 DATE 03/C9/77).  
 DATE 41276 FLIGHT NO. C-372 GROUND LEVEL ALTITUDE (M)= 6

ALTITUDE (M)	TOTAL VOLUME SCATTERING COEFFICIENT (PER M)				
	FILTERS	2	4	3	5
4530		4.85E-05	2.45E-05	1.74E-05	1.36E-05
4560		4.73E-05	2.65E-05	1.73E-05	1.35E-05
4590		4.73E-05	2.51E-05	1.41E-05	1.33E-05
4620		4.71E-05	2.45E-05	1.37E-05	1.32E-05
4650		4.68E-05	2.51E-05	1.42E-05	1.31E-05
4680		4.47E-05	2.24E-05	1.51E-05	1.29E-05
4710		4.49E-05	2.26E-05	1.43E-05	1.28E-05
4740		4.51E-05	2.27E-05	1.50E-05	1.26E-05
4770		4.55E-05	2.53E-05	1.53E-05	1.25E-05
4800		4.54E-05	2.45E-05	1.56E-05	1.26E-05
4830		4.55E-05	2.59E-05	1.46E-05	1.27E-05
4860		4.45E-05	2.27E-05	1.23E-05	1.28E-05
4890		4.44E-05	2.26E-05	1.26E-05	1.29E-05
4920		4.43E-05	2.62E-05	1.29E-05	1.29E-05
4950		4.39E-05	2.48E-05	1.32E-05	1.30E-05
4980		4.38E-05	2.27E-05	1.39E-05	1.45E-05
5010		4.38E-05	2.54E-05	1.45E-05	(1.45E-05 )
5040		4.35E-05	2.50E-05	1.48E-05	(1.44E-05 )
5070		4.32E-05	2.26E-05	1.51E-05	(1.44E-05 )
5100		4.36E-05	2.53E-05	1.54E-05	(1.43E-05 )
5130		4.37E-05	2.49E-05	1.22E-05	(1.43E-05 )
5160		4.39E-05	2.45E-05	1.28E-05	(1.42E-05 )
5190		4.32E-05	2.50E-05	1.33E-05	(1.42E-05 )
5220		4.32E-05	2.56E-05	1.37E-05	(1.42E-05 )
5250		4.44E-05	2.57E-05	1.36E-05	(1.41E-05 )
5280		4.32E-05	2.59E-05	1.43E-05	(1.41E-05 )
5310		4.33E-05	2.43E-05	1.49E-05	(1.40E-05 )
5340		4.32E-05	2.51E-05	1.53E-05	(1.40E-05 )
5370		4.32E-05	2.58E-05	1.44E-05	(1.39E-05 )
5400		4.47E-05	2.38E-05	1.26E-05	(1.39E-05 )
5430		4.41E-05	2.20E-05	1.30E-05	(1.39E-05 )
5460		4.47E-05	2.47E-05	1.32E-05	(1.38E-05 )
5490		4.41E-05	2.26E-05	1.47E-05	(1.38E-05 )
5520		4.49E-05	2.64E-05	1.46E-05	(1.37E-05 )
5550		4.59E-05	3.13E-05	1.49E-05	(1.37E-05 )
5580		4.46E-05	3.30E-05	1.40E-05	(1.36E-05 )
5610		4.41E-05	3.47E-05	1.32E-05	(1.36E-05 )
5640		4.37E-05	3.29E-05	1.41E-05	(1.35E-05 )
5670		4.47E-05	3.66E-05	1.47E-05	(1.35E-05 )
5700		4.57E-05	3.65E-05	1.52E-05	(1.35E-05 )
5730		(4.56E-05 )	3.59E-05	(1.51E-05 )	(1.34E-05 )
5760		(4.54E-05 )	3.95E-05	(1.51E-05 )	(1.34E-05 )
5790		(4.53E-05 )	(3.93E-05 )	(1.50E-05 )	(1.33E-05 )
5820		(4.52E-05 )	(3.92E-05 )	(1.50E-05 )	(1.33E-05 )
5850		(4.50E-05 )	(3.91E-05 )	(1.50E-05 )	(1.32E-05 )
5880		(4.49E-05 )	(3.90E-05 )	(1.49E-05 )	(1.32E-05 )
5910		(4.47E-05 )	(3.88E-05 )	(1.49E-05 )	(1.32E-05 )
5940		(4.46E-05 )	(3.87E-05 )	(1.48E-05 )	(1.31E-05 )
5970		(4.44E-05 )	(3.86E-05 )	(1.48E-05 )	(1.31E-05 )
6000		(4.43E-05 )	(3.85E-05 )	(1.47E-05 )	(1.30E-05 )

FIRST DATA ALT      480                      420                      270                      600  
 LAST DATA ALT      5700                      5760                      5700                      4980

**FLIGHT NO. C-372**  
**VERTICAL BEAM TRANSMITTANCE FROM GROUND TO ALTITUDE**

ALTITUDE (M)	VERTICAL BEAM TRANSMITTANCE FROM GROUND TO ALTITUDE			
	FILTERS 2	4	3	5
0	1.00E 00	1.00E 00	1.00E 00	1.00E 00
300	9.21E-01	9.26E-01	9.14E-01	9.63E-01
600	8.52E-01	8.56E-01	8.33E-01	9.28E-01
900	7.95E-01	7.92E-01	7.56E-01	8.92E-01
1200	7.44E-01	7.35E-01	6.77E-01	8.57E-01
1500	6.93E-01	6.83E-01	6.00E-01	8.22E-01
1800	6.29E-01	6.26E-01	5.12E-01	7.85E-01
2100	6.06E-01	5.74E-01	4.37E-01	7.55E-01
2400	5.91E-01	5.41E-01	4.17E-01	7.38E-01
2700	5.77E-01	5.35E-01	4.15E-01	7.33E-01
3000	5.64E-01	5.29E-01	4.12E-01	7.30E-01
3300	5.53E-01	5.24E-01	4.09E-01	7.27E-01
3600	5.43E-01	5.19E-01	4.06E-01	7.23E-01
3900	5.34E-01	5.14E-01	4.04E-01	7.20E-01
4200	5.26E-01	5.10E-01	4.01E-01	7.17E-01
4500	5.18E-01	5.05E-01	3.99E-01	7.13E-01
4800	5.11E-01	5.02E-01	3.98E-01	7.11E-01
5100	5.04E-01	4.98E-01	3.96E-01	7.08E-01
5400	4.98E-01	4.94E-01	3.94E-01	7.05E-01
5700	4.91E-01	4.90E-01	3.93E-01	7.02E-01
6000	4.84E-01	4.84E-01	3.91E-01	6.99E-01

**FLIGHT NO. C-372**  
**EQUIVALENT ATTENUATION LENGTH**

(JOB 2243 DATE 03/09/77)  
 DATE 41276 FLIGHT NO. C-372 GROUND LEVEL ALTITUDE (M)= 6

ALTITUDE (M)	EQUIVALENT ATTENUATION LENGTH (M)			
	FILTERS 2	4	3	5
0	3.61E 03	3.82E 03	3.29E 03	7.82E 03
300	3.67E 03	3.88E 03	3.33E 03	7.94E 03
600	3.73E 03	3.87E 03	3.29E 03	8.04E 03
900	3.92E 03	3.85E 03	3.21E 03	7.87E 03
1200	4.05E 03	3.90E 03	3.08E 03	7.78E 03
1500	4.10E 03	3.94E 03	2.94E 03	7.65E 03
1800	3.88E 03	3.85E 03	2.69E 03	7.46E 03
2100	4.19E 03	3.78E 03	2.54E 03	7.48E 03
2400	4.57E 03	3.91E 03	2.75E 03	7.91E 03
2700	4.91E 03	4.31E 03	3.07E 03	8.71E 03
3000	5.24E 03	4.71E 03	3.38E 03	9.52E 03
3300	5.57E 03	5.11E 03	3.69E 03	1.03E 04
3600	5.90E 03	5.49E 03	3.99E 03	1.11E 04
3900	6.22E 03	5.87E 03	4.30E 03	1.19E 04
4200	6.53E 03	6.23E 03	4.60E 03	1.26E 04
4500	6.84E 03	6.59E 03	4.90E 03	1.33E 04
4800	7.15E 03	6.96E 03	5.20E 03	1.41E 04
5100	7.45E 03	7.32E 03	5.50E 03	1.48E 04
5400	7.74E 03	7.66E 03	5.80E 03	1.54E 04
5700	8.01E 03	7.99E 03	6.10E 03	1.61E 04
6000	8.28E 03	8.27E 03	6.39E 03	1.68E 04

FLIGHT C-373 – 1 MAY 1976 – DESCRIPTION OF FLIGHT AND WEATHER CHARACTERISTICS

Filter Identification	Data Interval			Solar Zenith Angle			Maximum Flight Altitude (meters)	Average Terrain Elevation (meters)
	Start (GMT)	End (GMT)	Elapsed (hrs)	Initial ST&LV (degrees)	Solar Transit (degrees)	Final VPRO (degrees)		
2 and 3	1056	1250	1.9	38.5	35.7	36.8	5910	60
4 and 5	1255	1446	1.9	37.0	—	48.1	5880	60

Flight C-373 was a midday flight, spanning local apparent noon. There were multiple layers of scattered to broken clouds resulting in a general overcast at all flight altitudes.

The approximate east-west track was located between Bournemouth-Hurn and Yeovilton near the south central coast of England. Typical terrain features were rolling green fields and woods interspersed with occasional brown fields and small towns.

The in-flight observer reported overcast cirrostratus clouds at the beginning of the flight with some scattered cumulus forming at 1350 meters (4500 feet) after 1130 GMT. Scattered to broken altostratus at 4200 meters (14000 feet) were present after 1200 GMT. This altostratus layer was broken to overcast at the west end of the track.

Data from Yeovilton, 16 kilometers northwest of the track center point, show 3/8 of altostratus at altitudes varying from 2700 to 4500 meters (9000 to 15000 feet) and 6/8 to 7/8 of cirrostratus at 6000 meters (20000 feet). Near the end of the flight there was also a 5/8 layer of stratocumulus at 1500 meters (5000 feet). Visibility of 8 kilometers in haze improved to 15 kilometers and then decreased to 12 kilometers.

Bournemouth-Hurn, 45 kilometers eastsoutheast of the flight track center point, reported 1/8 cumulus at 1200 meters (4000 feet), altostratus and altocumulus varying from 1/8 to 3/8 in amount and 3000 to 4800 meters (10000 to 16000 feet) in height, 7/8 cirrostratus decreasing from 7500 to 6000 meters (25000 feet) in late afternoon. Visibility of 25 kilometers decreased to 15 kilometers.

The radiosonde station at Crawley was 160 kilometers east and downstream from the flight track center point.

The surface charts show an occluded system passing from Ireland through Britain throughout the day. The warm front part of this system was approaching the track during the flight but was weak. High pressure was centered over Belgium at 0600 GMT and moved to Luxemburg at 1800 GMT. The 500-millibar charts show the area in a col with light and variable winds. The airmass was stable continental polar.

# FLIGHT NO. C-373

YEOVIL

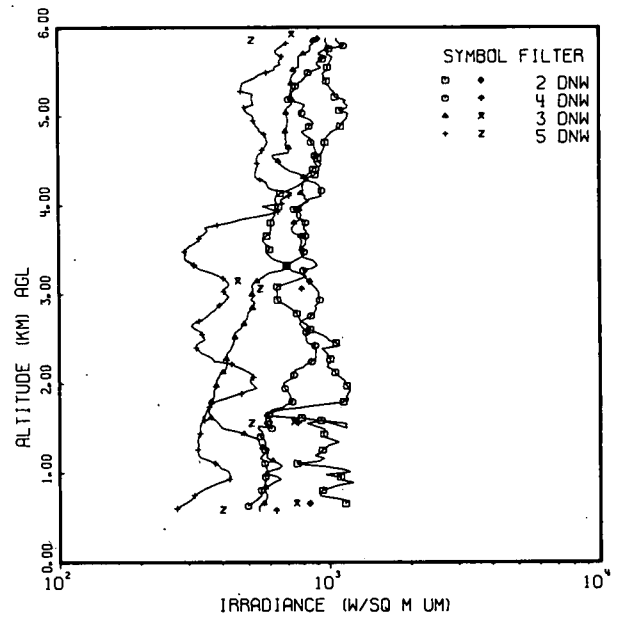
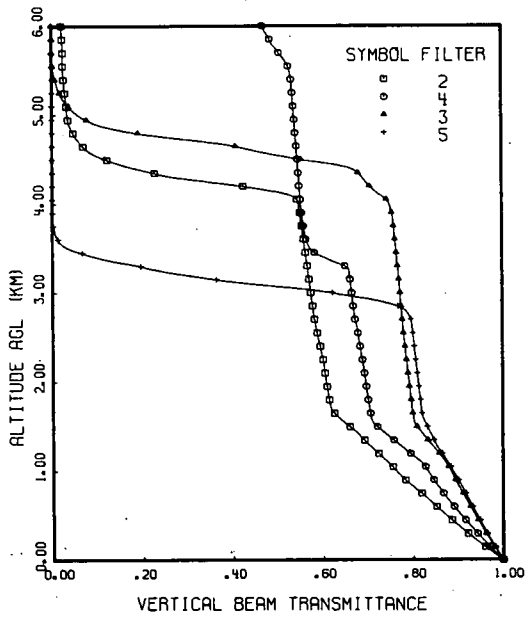
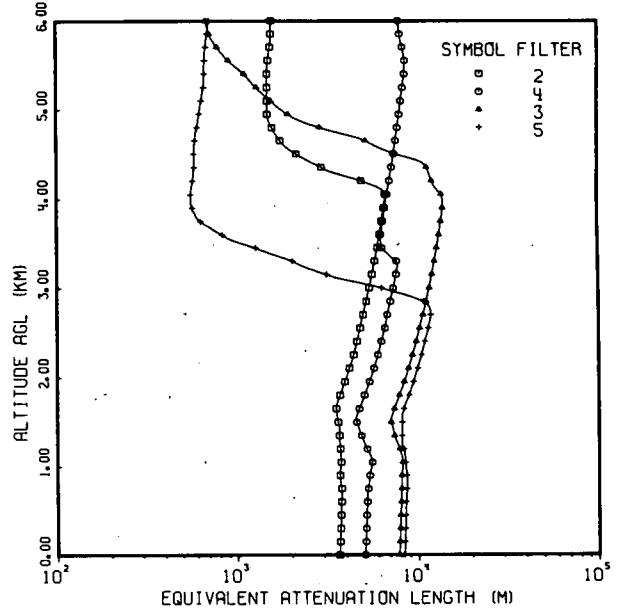
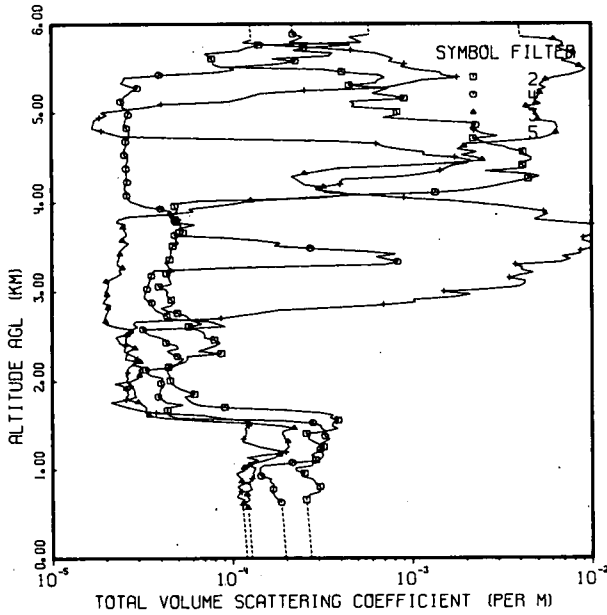

**FLIGHT NO. C-373**  
**TOTAL VOLUME SCATTERING COEFFICIENT**

(JOB 5940 DATE 03/08/77)  
 DATE 50176 FLIGHT NO. C-373 GROUND LEVEL ALTITUDE (M)= 61

ALTITUDE (M)	TOTAL VOLUME SCATTERING COEFFICIENT (PER M)			
	FILTERS	2	4	3
0	(2.74E-04 )	(1.98E-04 )	(1.29E-04 )	(1.20E-04 )
30	(2.73E-04 )	(1.97E-04 )	(1.28E-04 )	(1.20E-04 )
60	(2.72E-04 )	(1.96E-04 )	(1.28E-04 )	(1.17E-04 )
90	(2.72E-04 )	(1.96E-04 )	(1.27E-04 )	(1.19E-04 )
120	(2.71E-04 )	(1.95E-04 )	(1.27E-04 )	(1.19E-04 )
150	(2.70E-04 )	(1.95E-04 )	(1.27E-04 )	(1.19E-04 )
180	(2.69E-04 )	(1.94E-04 )	(1.26E-04 )	(1.18E-04 )
210	(2.69E-04 )	(1.94E-04 )	(1.26E-04 )	(1.18E-04 )
240	(2.68E-04 )	(1.93E-04 )	(1.26E-04 )	(1.18E-04 )
270	(2.67E-04 )	(1.93E-04 )	(1.25E-04 )	(1.17E-04 )
300	(2.67E-04 )	(1.92E-04 )	(1.25E-04 )	(1.17E-04 )
330	(2.66E-04 )	(1.92E-04 )	(1.25E-04 )	(1.17E-04 )
360	(2.65E-04 )	(1.91E-04 )	(1.24E-04 )	(1.16E-04 )
390	(2.65E-04 )	(1.91E-04 )	(1.24E-04 )	(1.16E-04 )
420	(2.64E-04 )	(1.90E-04 )	(1.24E-04 )	(1.16E-04 )
450	(2.63E-04 )	(1.90E-04 )	(1.23E-04 )	(1.15E-04 )
480	(2.62E-04 )	(1.89E-04 )	(1.23E-04 )	(1.15E-04 )
510	(2.62E-04 )	(1.89E-04 )	(1.23E-04 )	(1.15E-04 )
540	(2.61E-04 )	(1.88E-04 )	(1.22E-04 )	(1.14E-04 )
570	(2.60E-04 )	(1.88E-04 )	1.22E-04	(1.14E-04 )
600	(2.59E-04 )	(1.87E-04 )	1.21E-04	1.14E-04
630	(2.59E-04 )	1.87E-04	1.16E-04	1.12E-04
660	2.58E-04	1.81E-04	1.25E-04	1.17E-04
690	2.58E-04	1.73E-04	1.22E-04	1.06E-04
720	2.69E-04	1.70E-04	1.21E-04	1.08E-04
750	3.05E-04	1.67E-04	1.19E-04	1.13E-04
780	3.09E-04	1.69E-04	1.29E-04	1.11E-04
810	3.07E-04	1.71E-04	1.25E-04	1.07E-04
840	2.91E-04	1.69E-04	1.26E-04	1.14E-04
870	2.86E-04	1.61E-04	1.13E-04	1.25E-04
900	2.80E-04	1.65E-04	1.12E-04	1.29E-04
930	2.43E-04	1.44E-04	1.09E-04	1.32E-04
960	2.52E-04	1.42E-04	1.05E-04	1.30E-04
990	2.27E-04	1.43E-04	1.16E-04	1.33E-04
1020	2.23E-04	1.43E-04	1.16E-04	1.35E-04
1050	2.79E-04	1.48E-04	1.25E-04	1.23E-04
1080	2.79E-04	2.16E-04	1.34E-04	1.26E-04
1110	2.91E-04	3.06E-04	1.54E-04	1.39E-04
1140	2.91E-04	3.15E-04	1.72E-04	1.20E-04
1170	2.73E-04	3.20E-04	1.83E-04	1.48E-04
1200	2.96E-04	3.13E-04	1.92E-04	1.99E-04
1230	3.04E-04	3.08E-04	1.98E-04	1.68E-04
1260	3.23E-04	3.08E-04	2.06E-04	1.42E-04
1290	3.03E-04	3.08E-04	2.02E-04	1.28E-04
1320	2.83E-04	3.26E-04	2.04E-04	1.15E-04
1350	2.66E-04	3.48E-04	1.96E-04	1.15E-04
1380	2.66E-04	3.28E-04	1.95E-04	1.19E-04
1410	2.59E-04	3.25E-04	1.90E-04	1.19E-04
1440	3.35E-04	3.29E-04	1.91E-04	1.20E-04
1470	3.86E-04	3.12E-04	2.22E-04	1.18E-04
1500	3.59E-04	3.11E-04	1.85E-04	1.24E-04

**FLIGHT NO. C-373**  
**TOTAL VOLUME SCATTERING COEFFICIENT**

(JOB 5940 DATE 03/CP/77)  
 DATE 50176 FLIGHT NO. C-373 GROUND LEVEL ALTITUDE (M)= 61

ALTITUDE (M)	TOTAL VOLUME SCATTERING COEFFICIENT (PER M)			
	FILTERS	2	4	3
1530	3.63E-04	2.81E-04	1.27E-04	1.30E-04
1560	3.87E-04	1.85E-04	6.89E-05	1.17E-04
1590	3.49E-04	4.97E-05	4.24E-05	8.47E-05
1620	3.66E-04	4.47E-05	3.46E-05	7.04E-05
1650	3.06E-04	4.37E-05	3.32E-05	3.78E-05
1680	1.98E-04	4.37E-05	3.33E-05	3.06E-05
1710	9.10E-05	4.41E-05	3.35E-05	2.67E-05
1740	6.50E-05	5.33E-05	3.20E-05	2.36E-05
1770	5.92E-05	4.26E-05	3.01E-05	2.12E-05
1800	5.70E-05	4.11E-05	2.63E-05	2.58E-05
1830	5.48E-05	3.89E-05	2.61E-05	2.93E-05
1860	6.18E-05	3.98E-05	2.66E-05	2.88E-05
1890	5.65E-05	3.98E-05	2.62E-05	2.87E-05
1920	5.12E-05	4.03E-05	2.59E-05	2.85E-05
1950	4.82E-05	4.16E-05	2.49E-05	2.74E-05
1980	4.62E-05	4.03E-05	2.23E-05	2.67E-05
2010	4.55E-05	4.07E-05	2.77E-05	2.59E-05
2040	4.60E-05	4.12E-05	3.01E-05	2.67E-05
2070	4.51E-05	3.52E-05	3.07E-05	2.58E-05
2100	4.42E-05	3.37E-05	3.15E-05	2.63E-05
2130	4.38E-05	3.31E-05	3.04E-05	2.61E-05
2160	4.44E-05	4.54E-05	3.22E-05	2.69E-05
2190	4.89E-05	5.01E-05	2.79E-05	2.83E-05
2220	5.51E-05	5.11E-05	3.09E-05	2.89E-05
2250	5.70E-05	5.39E-05	2.55E-05	2.99E-05
2280	5.60E-05	4.97E-05	2.59E-05	2.87E-05
2310	8.74E-05	4.66E-05	2.61E-05	2.68E-05
2340	6.49E-05	4.35E-05	2.64E-05	2.52E-05
2370	7.32E-05	5.04E-05	2.90E-05	2.54E-05
2400	8.14E-05	4.94E-05	2.75E-05	2.56E-05
2430	8.62E-05	4.30E-05	2.60E-05	2.38E-05
2460	8.00E-05	4.30E-05	2.57E-05	2.35E-05
2490	7.00E-05	3.98E-05	2.60E-05	2.26E-05
2520	7.08E-05	3.49E-05	2.62E-05	2.50E-05
2550	6.94E-05	3.30E-05	2.83E-05	2.70E-05
2580	6.36E-05	3.20E-05	2.78E-05	2.82E-05
2610	5.76E-05	9.17E-05	2.27E-05	2.99E-05
2640	6.80E-05	8.28E-05	2.01E-05	2.82E-05
2670	6.19E-05	7.40E-05	1.99E-05	2.95E-05
2700	5.79E-05	4.42E-05	1.97E-05	8.71E-05
2730	5.60E-05	4.35E-05	2.00E-05	1.11E-04
2760	4.98E-05	4.09E-05	2.02E-05	1.46E-04
2790	4.36E-05	3.79E-05	2.05E-05	1.80E-04
2820	4.03E-05	3.69E-05	2.05E-05	3.76E-04
2850	4.61E-05	3.58E-05	2.14E-05	6.99E-04
2880	4.78E-05	3.59E-05	1.93E-05	1.05E-03
2910	4.61E-05	3.36E-05	1.97E-05	1.02E-03
2940	4.47E-05	3.26E-05	2.03E-05	1.74E-03
2970	4.33E-05	3.29E-05	2.03E-05	2.12E-03
3000	4.42E-05	3.33E-05	1.98E-05	1.51E-03

**FLIGHT NO. C-373**  
**TOTAL VOLUME SCATTERING COEFFICIENT**

(JOB 594C DATE 03/08/77)  
 DATE 50176 FLIGHT NO. C-373 GROUND LEVEL ALTITUDE (M)= 61

ALTITUDE (M)	FILTERS	TOTAL VOLUME SCATTERING COEFFICIENT (PER M)			
		2	4	3	5
3030	4.30E-05	3.38E-05	2.03E-05	2.72E-03	
3060	3.92E-05	3.42E-05	2.07E-05	4.02E-03	
3090	4.63E-05	3.46E-05	2.06E-05	4.26E-03	
3120	4.56E-05	3.50E-05	2.00E-05	4.29E-03	
3150	4.49E-05	3.54E-05	2.16E-05	3.51E-03	
3180	4.41E-05	3.58E-05	2.32E-05	3.96E-03	
3210	4.34E-05	3.62E-05	2.44E-05	4.76E-03	
3240	4.82E-05	3.69E-05	2.37E-05	4.09E-03	
3270	4.48E-05	1.05E-04	2.48E-05	4.13E-03	
3300	4.43E-05	7.19E-04	2.33E-05	3.78E-03	
3330	4.26E-05	8.37E-04	2.33E-05	6.83E-03	
3360	4.54E-05	7.37E-04	2.35E-05	7.66E-03	
3390	4.61E-05	6.37E-04	2.38E-05	6.88E-03	
3420	4.59E-05	8.14E-04	2.40E-05	8.64E-03	
3450	4.59E-05	5.44E-04	2.38E-05	8.73E-03	
3480	4.59E-05	2.74E-04	2.47E-05	1.16E-02	
3510	4.70E-05	1.73E-04	2.56E-05	1.33E-02	
3540	5.07E-05	1.86E-04	2.68E-05	1.11E-02	
3570	4.91E-05	1.44E-04	2.46E-05	8.88E-03	
3600	4.84E-05	9.60E-05	2.50E-05	9.08E-03	
3630	5.04E-05	4.81E-05	2.61E-05	1.00E-02	
3660	5.37E-05	4.90E-05	2.58E-05	1.02E-02	
3690	5.26E-05	4.91E-05	2.53E-05	1.07E-02	
3720	5.19E-05	5.33E-05	2.49E-05	1.21E-02	
3750	5.24E-05	6.24E-05	2.58E-05	1.14E-02	
3780	4.85E-05	4.88E-05	2.29E-05	6.76E-03	
3810	4.84E-05	5.27E-05	2.38E-05	4.84E-03	
3840	4.62E-05	4.54E-05	2.65E-05	5.24E-03	
3870	4.80E-05	4.55E-05	4.54E-05	5.73E-03	
3900	4.98E-05	4.64E-05	6.15E-05	5.44E-03	
3930	4.92E-05	4.03E-05	5.80E-05	4.26E-03	
3960	4.83E-05	3.25E-05	7.96E-05	3.32E-03	
3990	4.79E-05	2.98E-05	1.04E-04	2.37E-03	
4020	6.47E-05	2.71E-05	1.28E-04	1.63E-03	
4050	3.04E-04	2.67E-05	2.47E-04	9.07E-04	
4080	4.31E-04	2.62E-05	4.58E-04	6.13E-04	
4110	1.36E-03	2.67E-05	4.03E-04	3.30E-04	
4140	2.10E-03	2.55E-05	2.96E-04	3.18E-04	
4170	2.64E-03	2.55E-05	3.25E-04	2.91E-04	
4200	3.17E-03	2.59E-05	2.52E-04	4.03E-04	
4230	3.79E-03	2.64E-05	2.40E-04	4.08E-04	
4260	4.48E-03	2.60E-05	2.29E-04	4.14E-04	
4290	5.17E-03	2.62E-05	2.15E-04	8.91E-04	
4320	4.33E-03	2.61E-05	2.55E-04	1.17E-03	
4350	2.58E-03	2.60E-05	3.11E-04	1.45E-03	
4380	4.35E-03	2.59E-05	3.86E-04	1.56E-03	
4410	4.17E-03	2.59E-05	9.52E-04	1.68E-03	
4440	3.98E-03	2.62E-05	1.72E-03	2.07E-03	
4470	4.65E-03	2.66E-05	2.50E-03	2.14E-03	
4500	4.66E-03	2.65E-05	2.29E-03	1.75E-03	

**FLIGHT NO. C-373**  
**TOTAL VOLUME SCATTERING COEFFICIENT**

(JOB 5940 DATE 03/08/77)  
 DATE 50176 FLIGHT NO. C-373 GROUND LEVEL ALTITUDE (M)= 61

ALTITUDE (M)	TOTAL VOLUME SCATTERING COEFFICIENT (PER M)				
	FILTERS	2	4	3	5
4530		4.21E-03	2.54E-05	1.90E-03	1.16E-03
4560		4.19E-03	2.59E-05	2.32E-03	1.18E-03
4590		3.55E-03	2.52E-05	1.81E-03	8.76E-04
4620		3.29E-03	2.59E-05	1.97E-03	7.05E-04
4650		2.70E-03	2.60E-05	2.05E-03	6.39E-04
4680		2.46E-03	2.58E-05	3.43E-03	3.73E-04
4710		2.22E-03	2.68E-05	5.25E-03	8.03E-05
4740		3.03E-03	2.70E-05	5.90E-03	2.41E-05
4770		2.46E-03	2.70E-05	6.40E-03	2.15E-05
4800		2.30E-03	2.70E-05	6.46E-03	1.89E-05
4830		2.14E-03	2.62E-05	6.52E-03	1.68E-05
4860		2.29E-03	2.53E-05	6.42E-03	1.69E-05
4890		2.13E-03	2.57E-05	6.33E-03	1.72E-05
4920		1.14E-03	2.57E-05	5.07E-03	1.72E-05
4950		6.96E-04	2.63E-05	5.11E-03	1.85E-05
4980		8.42E-04	2.68E-05	5.02E-03	2.03E-05
5010		8.36E-04	2.72E-05	4.83E-03	1.88E-05
5040		8.30E-04	2.65E-05	4.65E-03	2.53E-05
5070		4.68E-04	2.47E-05	4.37E-03	3.38E-05
5100		4.84E-04	2.52E-05	5.28E-03	4.10E-05
5130		4.55E-04	2.43E-05	4.87E-03	9.88E-05
5160		9.18E-04	2.51E-05	5.04E-03	1.14E-04
5190		8.00E-04	2.56E-05	5.12E-03	1.29E-04
5220		6.10E-04	2.69E-05	5.23E-03	1.47E-04
5250		6.78E-04	2.80E-05	5.09E-03	2.56E-04
5280		7.47E-04	3.01E-05	5.61E-03	6.87E-04
5310		4.52E-04	2.67E-05	5.17E-03	8.41E-04
5340		6.39E-04	2.44E-05	5.39E-03	9.94E-04
5370		6.53E-04	2.53E-05	5.62E-03	1.15E-03
5400		7.15E-04	2.54E-05	6.36E-03	1.80E-03
5430		6.60E-04	3.98E-05	7.79E-03	1.48E-03
5460		4.13E-04	8.15E-05	8.86E-03	1.45E-03
5490		3.28E-04	1.04E-04	9.35E-03	1.05E-03
5520		8.60E-05	9.67E-05	8.61E-03	8.81E-04
5550		7.98E-05	1.79E-04	8.00E-03	9.19E-04
5580		7.89E-05	2.28E-04	6.89E-03	7.53E-04
5610		7.81E-05	1.70E-04	7.81E-03	7.94E-04
5640		7.47E-05	3.53E-04	7.90E-03	7.16E-04
5670		7.14E-05	3.68E-04	7.98E-03	6.38E-04
5700		1.11E-04	2.21E-04	6.90E-03	4.64E-04
5730		1.22E-04	2.54E-04	6.53E-03	3.05E-04
5760		1.43E-04	4.57E-04	6.97E-03	1.75E-04
5790		5.31E-04	2.11E-04	6.95E-03	1.16E-04
5820		4.94E-04	2.31E-04	6.20E-03	1.30E-04
5850		4.56E-04	2.51E-04	4.05E-03	(1.29E-04 )
5880		5.88E-04	2.21E-04	(4.04E-03 )	(1.29E-04 )
5910	(5.86E-04 )	(2.20E-04 )	(4.02E-03 )	(1.29E-04 )	
5940	(5.84E-04 )	(2.20E-04 )	(4.01E-03 )	(1.28E-04 )	
5970	(5.82E-04 )	(2.19E-04 )	(4.00E-03 )	(1.28E-04 )	
6000	(5.80E-04 )	(2.18E-04 )	(3.98E-03 )	(1.27E-04 )	
FIRST DATA ALT	660	630	570	600	
LAST DATA ALT	5880	5880	5850	5820	

**FLIGHT NO. C-373**  
**VERTICAL BEAM TRANSMITTANCE FROM GROUND TO ALTITUDE**

ALTITUDE (M)	VERTICAL BEAM TRANSMITTANCE FROM GROUND TO ALTITUDE			
	FILTERS 2	4	3	5
0	1.00E 00	1.00E 00	1.00E 00	1.00E 00
300	9.22E-01	9.43E-01	9.63E-01	9.65E-01
600	8.52E-01	8.91E-01	9.28E-01	9.32E-01
900	7.83E-01	8.46E-01	8.95E-01	9.01E-01
1200	7.23E-01	7.94E-01	8.59E-01	8.65E-01
1500	6.60E-01	7.21E-01	8.09E-01	8.32E-01
1800	6.14E-01	7.01E-01	7.96E-01	8.17E-01
2100	6.05E-01	6.92E-01	7.89E-01	8.10E-01
2400	5.95E-01	6.83E-01	7.83E-01	8.03E-01
2700	5.82E-01	6.72E-01	7.77E-01	7.96E-01
3000	5.74E-01	6.65E-01	7.72E-01	6.22E-01
3300	5.67E-01	6.50E-01	7.67E-01	1.97E-01
3600	5.59E-01	5.63E-01	7.62E-01	1.32E-02
3900	5.50E-01	5.55E-01	7.55E-01	1.05E-03
4200	4.25E-01	5.50E-01	7.06E-01	6.32E-04
4500	1.23E-01	5.45E-01	5.54E-01	4.30E-04
4800	4.75E-02	5.41E-01	1.91E-01	3.60E-04
5100	3.24E-02	5.37E-01	3.77E-02	3.57E-04
5400	2.66E-02	5.33E-01	7.69E-03	3.04E-04
5700	2.48E-02	5.06E-01	7.02E-04	2.27E-04
6000	2.18E-02	4.69E-01	1.47E-04	2.16E-04

**FLIGHT NO. C-373**  
**EQUIVALENT ATTENUATION LENGTH**

(JOB 5940 DATE 03/08/77)  
 DATE 50176 FLIGHT NO. C-373 GROUND LEVEL ALTITUDE (M)= 61

ALTITUDE (M)	EQUIVALENT ATTENUATION LENGTH (M)			
	FILTERS 2	4	3	5
0	3.65E 03	5.05E 03	7.78E 03	8.31E 03
300	3.70E 03	5.13E 03	7.89E 03	8.43E 03
600	3.75E 03	5.20E 03	8.00E 03	8.55E 03
900	3.68E 03	5.38E 03	8.08E 03	8.63E 03
1200	3.71E 03	5.20E 03	7.88E 03	8.29E 03
1500	3.61E 03	4.59E 03	7.07E 03	8.16E 03
1800	3.70E 03	5.06E 03	7.88E 03	8.89E 03
2100	4.18E 03	5.71E 03	8.88E 03	9.97E 03
2400	4.62E 03	6.29E 03	9.80E 03	1.10E 04
2700	4.99E 03	6.80E 03	1.07E 04	1.19E 04
3000	5.41E 03	7.35E 03	1.16E 04	6.32E 03
3300	5.81E 03	7.65E 03	1.25E 04	2.03E 03
3600	6.18E 03	6.27E 03	1.32E 04	8.31E 02
3900	6.53E 03	6.62E 03	1.39E 04	5.69E 02
4200	4.90E 03	7.02E 03	1.20E 04	5.70E 02
4500	2.14E 03	7.42E 03	7.61E 03	5.80E 02
4800	1.58E 03	7.82E 03	2.90E 03	6.05E 02
5100	1.49E 03	8.20E 03	1.56E 03	6.43E 02
5400	1.49E 03	8.57E 03	1.11E 03	6.67E 02
5700	1.54E 03	8.36E 03	7.85E 02	6.79E 02
6000	1.57E 03	7.92E 03	6.80E 02	7.11E 02

FLIGHT C-376 – 8 MAY 1976 – DESCRIPTION OF FLIGHT AND WEATHER CHARACTERISTICS

Filter Identification	Date Interval			Solar Zenith Angle			Maximum Flight Altitude (meters)	Average Terrain Elevation (meters)
	Start (GMT)	End (GMT)	Elapsed (hrs)	Initial ST&LV (degrees)	Solar Transit (degrees)	Final VPRO (degrees)		
2 and 3	0900	1047	1.8	50.0	–	37.2	6060	60
4 and 5	1053	1240	1.8	36.8	33.7	34.5	6120	60

Flight C-376 was a morning flight extending through local apparent noon. There was widespread haze with thin scattered clouds reported in nearby areas, although the in-flight pictures indicated clear skies along the track.

The approximate east-west track was located between Bournemouth-Hurn and Yeovilton near the south central coast of England. Typical terrain features were rolling green fields and woods interspersed with occasional brown fields and small towns.

The in-flight observer reported 2/8 thin cirrus early in the flight decreasing to 1/8 cover by 1055 GMT. Isolated cumulus clouds began forming at 1150 GMT and increased to 1/8 coverage at 600 meters (2000 feet) by 1220 GMT.

Data reported at Yeovilton, 16 kilometers northwest of the track center point, show 3/8 thin cirrus at 7500 meters (25000 feet) at 0900 GMT disappearing by 1200 GMT. A thin layer of haze decreased surface visibility to 2.5 kilometers at 0900 and gradually improved to 7 kilometers by 1400 GMT.

Bournemouth-Hurn, 45 kilometers eastsoutheast of the flight track center point, reported clear skies during the morning with 1/8 cumulus at 1500 meters (5000 feet) and 2/8 cirrus at 7500 meters (25000 feet) after 1300 GMT. Surface visibility was 4 to 5 kilometers with haze.

The radiosonde station at Crawley was 160 kilometers east and downstream from the flight track center point.

The surface charts show an occluded front passing through Mildenhall about 0600 GMT moving into the North Sea and weakening at 1200 GMT. Another cold front was approaching the west coast of Ireland. At 500 millibars there was a blocking stationary high over western Germany with light southwesterly flow over Britain. The airmass was unstable maritime polar.

# FLIGHT NO. C-376

YEOVIL

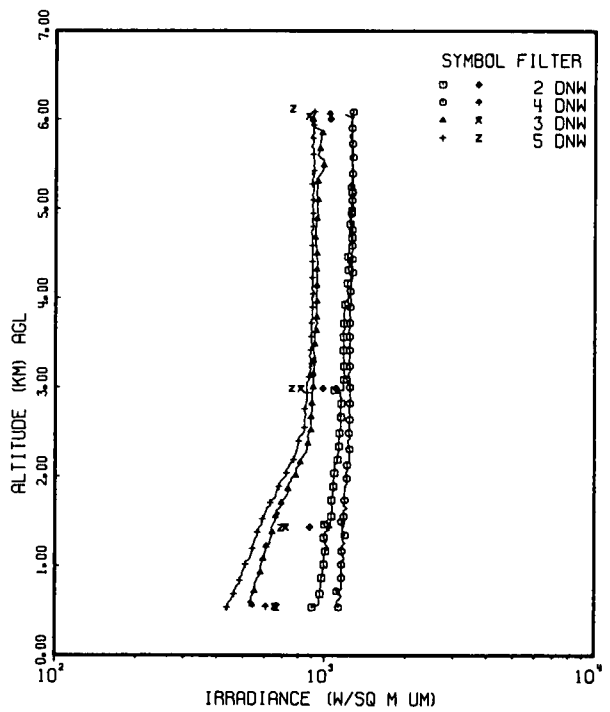
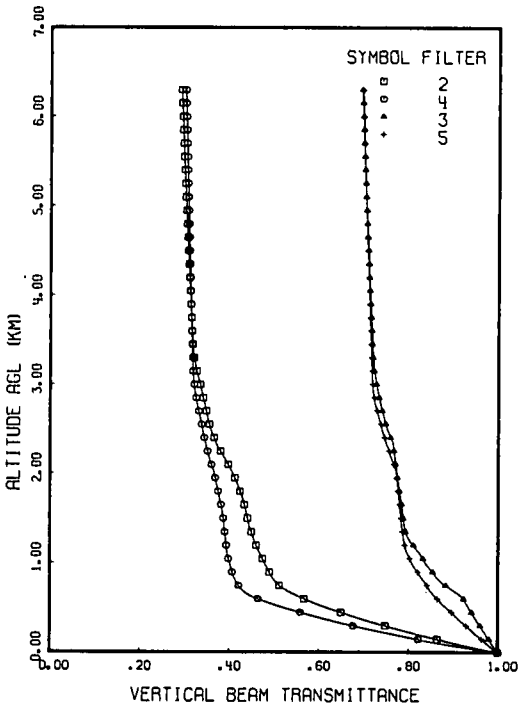
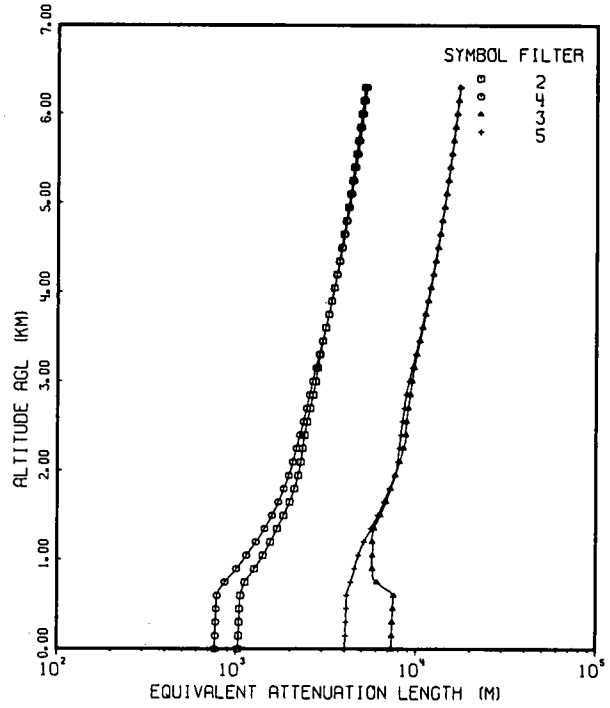
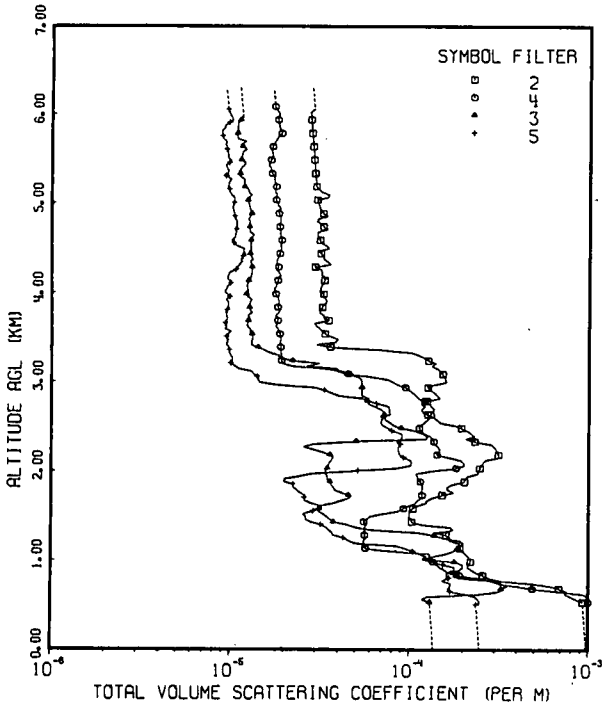

# FLIGHT NO. C-376

## TOTAL VOLUME SCATTERING COEFFICIENT

(JOB 2240 DATE 03/C9/77)  
 DATE 50876 FLIGHT NO. C-376 GROUND LEVEL ALTITUDE (M)= 61

ALTITUDE (M)	TOTAL VOLUME SCATTERING COEFFICIENT (PER M)			
	FILTERS	2	4	3
0	(9.78E-04 )	(1.32E-03 )	(1.37E-04 )	(2.48E-04 )
30	(9.73E-04 )	(1.31E-03 )	(1.36E-04 )	(2.47E-04 )
60	(9.70E-04 )	(1.31E-03 )	(1.36E-04 )	(2.46E-04 )
90	(9.68E-04 )	(1.31E-03 )	(1.36E-04 )	(2.46E-04 )
120	(9.66E-04 )	(1.30E-03 )	(1.35E-04 )	(2.45E-04 )
150	(9.63E-04 )	(1.30E-03 )	(1.35E-04 )	(2.45E-04 )
180	(9.61E-04 )	(1.30E-03 )	(1.35E-04 )	(2.44E-04 )
210	(9.58E-04 )	(1.29E-03 )	(1.34E-04 )	(2.43E-04 )
240	(9.56E-04 )	(1.29E-03 )	(1.34E-04 )	(2.43E-04 )
270	(9.53E-04 )	(1.29E-03 )	(1.34E-04 )	(2.42E-04 )
300	(9.51E-04 )	(1.28E-03 )	(1.33E-04 )	(2.41E-04 )
330	(9.48E-04 )	(1.28E-03 )	(1.33E-04 )	(2.41E-04 )
360	(9.46E-04 )	(1.28E-03 )	(1.33E-04 )	(2.40E-04 )
390	(9.43E-04 )	(1.27E-03 )	(1.32E-04 )	(2.40E-04 )
420	(9.41E-04 )	(1.27E-03 )	(1.32E-04 )	(2.39E-04 )
450	(9.38E-04 )	(1.27E-03 )	(1.32E-04 )	(2.38E-04 )
480	(9.35E-04 )	(1.26E-03 )	(1.31E-04 )	(2.38E-04 )
510	(9.33E-04 )	(1.26E-03 )	(1.31E-04 )	2.37E-04
540	9.30E-04	1.26E-03	1.31E-04	2.49E-04
570	8.59E-04	1.21E-03	1.17E-04	2.43E-04
600	8.00E-04	1.17E-03	1.26E-04	2.32E-04
630	7.39E-04	9.31E-04	2.48E-04	2.06E-04
660	7.56E-04	6.91E-04	3.21E-04	1.69E-04
690	6.86E-04	4.86E-04	3.26E-04	1.63E-04
720	6.16E-04	4.03E-04	3.51E-04	1.70E-04
750	4.95E-04	3.17E-04	3.28E-04	1.71E-04
780	3.22E-04	2.86E-04	3.06E-04	1.52E-04
810	2.78E-04	2.42E-04	1.96E-04	1.66E-04
840	2.57E-04	1.91E-04	1.83E-04	1.61E-04
870	2.35E-04	1.64E-04	1.71E-04	1.63E-04
900	2.22E-04	1.57E-04	1.90E-04	1.78E-04
930	2.11E-04	1.48E-04	1.99E-04	1.79E-04
960	2.12E-04	1.42E-04	1.98E-04	1.54E-04
990	2.19E-04	1.36E-04	1.79E-04	1.36E-04
1020	2.20E-04	1.34E-04	1.22E-04	1.18E-04
1050	2.13E-04	1.29E-04	1.36E-04	1.25E-04
1080	2.06E-04	1.30E-04	1.60E-04	1.13E-04
1110	1.98E-04	7.75E-05	1.77E-04	1.04E-04
1140	1.92E-04	5.69E-05	1.86E-04	9.43E-05
1170	1.91E-04	5.51E-05	1.95E-04	8.41E-05
1200	1.90E-04	5.55E-05	2.00E-04	4.92E-05
1230	1.68E-04	5.58E-05	1.90E-04	4.60E-05
1260	1.69E-04	5.74E-05	1.54E-04	4.28E-05
1290	1.60E-04	5.64E-05	1.38E-04	3.77E-05
1320	1.40E-04	5.65E-05	1.12E-04	3.69E-05
1350	1.75E-04	5.65E-05	6.05E-05	3.55E-05
1380	1.70E-04	5.64E-05	4.97E-05	3.43E-05
1410	1.16E-04	5.75E-05	4.47E-05	3.19E-05
1440	1.03E-04	5.58E-05	3.78E-05	2.82E-05
1470	1.03E-04	5.82E-05	3.62E-05	2.64E-05
1500	9.92E-05	6.02E-05	3.46E-05	2.64E-05

**FLIGHT NO. C-376**  
**TOTAL VOLUME SCATTERING COEFFICIENT**

(JOB 2240 DATE 03/09/77)  
 DATE 50876 FLIGHT NO. C-376 GROUND LEVEL ALTITUDE (M)= 61

ALTITUDE (M)	TOTAL VOLUME SCATTERING COEFFICIENT (PER M)				
	FILTERS	2	4	3	5
1530		9.97E-05	7.14E-05	3.29E-05	2.54E-05
1560		9.93E-05	8.67E-05	3.10E-05	2.90E-05
1590		1.05E-04	9.28E-05	3.16E-05	3.05E-05
1620		1.10E-04	9.90E-05	3.11E-05	3.21E-05
1650		1.24E-04	1.08E-04	3.78E-05	2.83E-05
1680		1.25E-04	1.11E-04	4.22E-05	2.59E-05
1710		1.34E-04	1.17E-04	4.68E-05	2.59E-05
1740		1.52E-04	1.17E-04	4.57E-05	2.62E-05
1770		1.76E-04	1.18E-04	4.12E-05	2.43E-05
1800		1.63E-04	1.18E-04	3.82E-05	2.34E-05
1830		1.61E-04	1.18E-04	3.75E-05	2.24E-05
1860		1.72E-04	1.18E-04	3.64E-05	2.23E-05
1890		2.03E-04	1.15E-04	3.60E-05	1.99E-05
1920		2.05E-04	1.11E-04	3.45E-05	2.01E-05
1950		2.11E-04	1.10E-04	3.49E-05	2.44E-05
1980		2.41E-04	1.09E-04	3.38E-05	2.90E-05
2010		2.43E-04	1.33E-04	3.39E-05	5.18E-05
2040		2.47E-04	1.82E-04	3.47E-05	8.52E-05
2070		2.52E-04	2.02E-04	3.53E-05	1.01E-04
2100		2.56E-04	2.00E-04	3.58E-05	1.03E-04
2130		2.63E-04	1.92E-04	3.66E-05	1.01E-04
2160		3.15E-04	1.66E-04	3.75E-05	9.22E-05
2190		3.13E-04	1.42E-04	3.59E-05	8.77E-05
2220		3.09E-04	1.45E-04	3.24E-05	8.72E-05
2250		3.03E-04	1.48E-04	2.89E-05	8.67E-05
2280		2.97E-04	1.44E-04	2.54E-05	8.62E-05
2310		2.85E-04	1.37E-04	2.94E-05	8.89E-05
2340		2.31E-04	1.37E-04	5.04E-05	8.45E-05
2370		2.06E-04	1.34E-04	1.25E-04	9.04E-05
2400		2.30E-04	1.31E-04	1.26E-04	9.10E-05
2430		2.20E-04	1.21E-04	1.17E-04	8.98E-05
2460		2.10E-04	1.15E-04	1.07E-04	7.92E-05
2490		1.95E-04	1.13E-04	8.97E-05	7.52E-05
2520		1.79E-04	1.16E-04	8.06E-05	7.06E-05
2550		1.47E-04	1.20E-04	7.77E-05	6.88E-05
2580		1.41E-04	1.26E-04	7.30E-05	6.98E-05
2610		1.36E-04	1.30E-04	7.23E-05	7.08E-05
2640		1.26E-04	1.31E-04	7.23E-05	7.79E-05
2670		1.18E-04	1.34E-04	7.24E-05	7.73E-05
2700		1.16E-04	1.37E-04	6.84E-05	7.67E-05
2730		1.23E-04	1.32E-04	6.32E-05	7.67E-05
2760		1.15E-04	1.28E-04	5.86E-05	6.53E-05
2790		1.25E-04	1.21E-04	5.80E-05	5.89E-05
2820		1.48E-04	1.11E-04	5.93E-05	5.40E-05
2850		1.43E-04	1.08E-04	5.39E-05	3.97E-05
2880		1.39E-04	1.04E-04	5.41E-05	3.65E-05
2910		1.31E-04	9.95E-05	5.41E-05	3.33E-05
2940		1.26E-04	9.46E-05	5.42E-05	2.95E-05
2970		1.35E-04	8.56E-05	5.40E-05	1.80E-05
3000		1.60E-04	8.06E-05	5.40E-05	1.44E-05

**FLIGHT NO. C-376**  
**TOTAL VOLUME SCATTERING COEFFICIENT**

(JOB 2240 DATE 03/09/77)  
 DATE 50876 FLIGHT NO. C-376 GROUND LEVEL ALTITUDE (M)= 61

ALTITUDE (M)	FILTERS	TOTAL VOLUME SCATTERING COEFFICIENT (PER M)			
		2	4	3	5
3030	1.58E-04	7.51E-05	5.36E-05	1.42E-05	
3060	1.56E-04	6.01E-05	5.09E-05	1.41E-05	
3090	1.53E-04	4.54E-05	4.48E-05	1.34E-05	
3120	1.49E-04	4.21E-05	3.91E-05	1.31E-05	
3150	1.42E-04	3.38E-05	3.96E-05	1.11E-05	
3180	1.33E-04	2.20E-05	2.66E-05	1.05E-05	
3210	1.40E-04	1.96E-05	3.15E-05	9.98E-06	
3240	1.27E-04	1.92E-05	2.22E-05	1.02E-05	
3270	1.22E-04	1.93E-05	1.86E-05	1.03E-05	
3300	1.13E-04	1.91E-05	1.86E-05	1.00E-05	
3330	1.02E-04	1.91E-05	1.65E-05	9.77E-06	
3360	6.93E-05	1.90E-05	1.54E-05	9.82E-06	
3390	3.61E-05	1.90E-05	1.42E-05	9.76E-06	
3420	3.01E-05	1.93E-05	1.30E-05	9.52E-06	
3450	3.87E-05	1.88E-05	1.31E-05	9.54E-06	
3480	4.01E-05	1.90E-05	1.32E-05	9.72E-06	
3510	3.63E-05	1.89E-05	1.32E-05	9.44E-06	
3540	3.36E-05	1.88E-05	1.32E-05	9.65E-06	
3570	3.24E-05	1.84E-05	1.29E-05	1.01E-05	
3600	3.12E-05	1.84E-05	1.28E-05	9.27E-06	
3630	3.02E-05	1.78E-05	1.23E-05	9.58E-06	
3660	2.92E-05	1.81E-05	1.24E-05	9.30E-06	
3690	3.51E-05	1.83E-05	1.26E-05	9.50E-06	
3720	3.29E-05	1.84E-05	1.28E-05	9.61E-06	
3750	3.32E-05	1.78E-05	1.25E-05	9.47E-06	
3780	3.12E-05	1.85E-05	1.32E-05	9.39E-06	
3810	3.14E-05	1.88E-05	1.28E-05	9.55E-06	
3840	3.23E-05	1.83E-05	1.27E-05	9.71E-06	
3870	3.33E-05	1.84E-05	1.27E-05	9.71E-06	
3900	3.42E-05	1.85E-05	1.28E-05	9.72E-06	
3930	3.40E-05	1.84E-05	1.31E-05	9.39E-06	
3960	3.27E-05	1.82E-05	1.24E-05	9.92E-06	
3990	3.29E-05	1.78E-05	1.22E-05	9.54E-06	
4020	3.12E-05	1.76E-05	1.26E-05	9.26E-06	
4050	3.17E-05	1.74E-05	1.25E-05	9.54E-06	
4080	3.22E-05	1.79E-05	1.23E-05	9.62E-06	
4110	3.28E-05	1.81E-05	1.24E-05	1.00E-05	
4140	3.33E-05	1.83E-05	1.26E-05	9.81E-06	
4170	3.39E-05	1.85E-05	1.30E-05	9.58E-06	
4200	3.20E-05	1.89E-05	1.31E-05	9.76E-06	
4230	3.22E-05	1.85E-05	1.31E-05	9.85E-06	
4260	3.19E-05	1.80E-05	1.31E-05	1.07E-05	
4290	2.94E-05	1.84E-05	1.32E-05	1.09E-05	
4320	3.61E-05	1.82E-05	1.32E-05	1.12E-05	
4350	3.42E-05	1.79E-05	1.28E-05	1.16E-05	
4380	3.27E-05	1.82E-05	1.33E-05	1.13E-05	
4410	3.33E-05	1.85E-05	1.30E-05	1.17E-05	
4440	3.17E-05	1.87E-05	1.28E-05	1.21E-05	
4470	3.08E-05	1.89E-05	1.27E-05	1.17E-05	
4500	3.53E-05	1.91E-05	1.30E-05	1.18E-05	

# FLIGHT NO. C-376

## TOTAL VOLUME SCATTERING COEFFICIENT

(JOB 2240 DATE 03/09/77)  
 DATE 50876 FLIGHT NO. C-376 GROUND LEVEL ALTITUDE (M)= 61

ALTITUDE (M)	FILTERS	TOTAL VOLUME SCATTERING COEFFICIENT (PER M)			
		2	4	3	5
4530	3.37E-05	1.89E-05	1.28E-05	1.07E-05	
4560	3.2CE-05	1.90E-05	1.29E-05	1.04E-05	
4590	3.14E-05	1.92E-05	1.30E-05	1.01E-05	
4620	3.07E-05	1.92E-05	1.30E-05	1.06E-05	
4650	3.05E-05	1.89E-05	1.34E-05	1.06E-05	
4680	3.02E-05	1.88E-05	1.27E-05	1.07E-05	
4710	3.46E-05	1.88E-05	1.28E-05	1.07E-05	
4740	3.27E-05	1.87E-05	1.27E-05	1.08E-05	
4770	3.21E-05	1.87E-05	1.26E-05	1.07E-05	
4800	3.02E-05	1.88E-05	1.28E-05	1.08E-05	
4830	3.06E-05	1.88E-05	1.25E-05	1.06E-05	
4860	3.47E-05	1.88E-05	1.28E-05	1.05E-05	
4890	3.27E-05	1.85E-05	1.31E-05	1.04E-05	
4920	3.19E-05	1.84E-05	1.29E-05	1.04E-05	
4950	3.11E-05	1.89E-05	1.27E-05	1.02E-05	
4980	3.10E-05	1.81E-05	1.26E-05	1.02E-05	
5010	3.06E-05	1.82E-05	1.25E-05	1.04E-05	
5040	3.02E-05	1.78E-05	1.24E-05	1.04E-05	
5070	3.47E-05	1.77E-05	1.27E-05	1.04E-05	
5100	3.52E-05	1.80E-05	1.30E-05	1.00E-05	
5130	3.19E-05	1.76E-05	1.24E-05	9.80E-06	
5160	3.08E-05	1.75E-05	1.25E-05	9.81E-06	
5190	2.97E-05	1.78E-05	1.18E-05	9.58E-06	
5220	2.97E-05	1.79E-05	1.18E-05	9.71E-06	
5250	2.96E-05	1.74E-05	1.18E-05	9.84E-06	
5280	2.95E-05	1.74E-05	1.18E-05	1.00E-05	
5310	2.94E-05	1.75E-05	1.11E-05	9.31E-06	
5340	2.94E-05	1.68E-05	1.12E-05	9.54E-06	
5370	2.93E-05	1.66E-05	1.11E-05	9.69E-06	
5400	2.92E-05	1.65E-05	1.14E-05	9.47E-06	
5430	2.91E-05	1.62E-05	1.17E-05	9.25E-06	
5460	2.90E-05	1.62E-05	1.20E-05	9.77E-06	
5490	2.90E-05	1.66E-05	1.14E-05	9.94E-06	
5520	2.89E-05	1.71E-05	1.14E-05	9.60E-06	
5550	2.88E-05	1.70E-05	1.15E-05	9.60E-06	
5580	2.87E-05	1.68E-05	1.15E-05	9.60E-06	
5610	2.86E-05	1.66E-05	1.22E-05	9.39E-06	
5640	2.86E-05	1.70E-05	1.15E-05	9.40E-06	
5670	2.85E-05	1.73E-05	1.13E-05	9.29E-06	
5700	2.84E-05	1.76E-05	1.21E-05	9.42E-06	
5730	2.83E-05	1.80E-05	1.08E-05	8.94E-06	
5760	2.83E-05	1.83E-05	1.08E-05	8.90E-06	
5790	2.82E-05	1.91E-05	1.08E-05	8.86E-06	
5820	2.81E-05	1.92E-05	1.09E-05	8.85E-06	
5850	2.80E-05	1.85E-05	1.09E-05	9.21E-06	
5880	2.79E-05	1.84E-05	1.08E-05	9.20E-06	
5910	2.79E-05	1.83E-05	1.09E-05	9.76E-06	
5940	2.78E-05	1.82E-05	1.13E-05	1.02E-05	
5970	2.77E-05	1.80E-05	1.16E-05	1.01E-05	
6000	2.76E-05	1.85E-05	1.16E-05	9.82E-06	
6030	2.76E-05	1.83E-05	(1.15E-05 )	9.73E-06	
6060	2.90E-05	1.77E-05	(1.15E-05 )	9.58E-06	
6090	(2.89E-05 )	1.75E-05	(1.14E-05 )	9.55E-06	
6120	(2.88E-05 )	(1.74E-05 )	(1.14E-05 )	(9.52E-06 )	
6150	(2.87E-05 )	(1.74E-05 )	(1.14E-05 )	(9.49E-06 )	
6180	(2.86E-05 )	(1.73E-05 )	(1.13E-05 )	(9.46E-06 )	
6210	(2.85E-05 )	(1.72E-05 )	(1.13E-05 )	(9.43E-06 )	
6240	(2.84E-05 )	(1.72E-05 )	(1.13E-05 )	(9.40E-06 )	
6270	(2.83E-05 )	(1.71E-05 )	(1.12E-05 )	(9.37E-06 )	
6300	(2.82E-05 )	(1.71E-05 )	(1.12E-05 )	(9.34E-06 )	

FIRST DATA ALT      540                      540                      540                      510  
 LAST DATA ALT      6060                      6090                      6000                      6090

**FLIGHT NO. C-376**  
**VERTICAL BEAM TRANSMITTANCE FROM GROUND TO ALTITUDE**

ALTITUDE (M)	VERTICAL BEAM FILTERS	2	4	3	TC	ALTITUDE	5
0		1.00E 00	1.00E 00	1.00E 00		0	1.00E 00
300		7.49E-01	6.77E-01	7.60E-01		300	9.29E-01
600		5.68E-01	4.64E-01	9.24E-01		600	8.65E-01
900		4.90E-01	4.07E-01	8.54E-01		900	8.21E-01
1200		4.61E-01	3.94E-01	8.11E-01		1200	7.92E-01
1500		4.41E-01	3.87E-01	7.88E-01		1500	7.83E-01
1800		4.25E-01	3.76E-01	7.79E-01		1800	7.77E-01
2100		3.98E-01	3.61E-01	7.71E-01		2100	7.67E-01
2400		3.67E-01	3.45E-01	7.60E-01		2400	7.46E-01
2700		3.49E-01	3.32E-01	7.41E-01		2700	7.29E-01
3000		3.35E-01	3.21E-01	7.28E-01		3000	7.19E-01
3300		3.21E-01	3.18E-01	7.20E-01		3300	7.17E-01
3600		3.17E-01	3.16E-01	7.17E-01		3600	7.15E-01
3900		3.14E-01	3.14E-01	7.15E-01		3900	7.13E-01
4200		3.11E-01	3.12E-01	7.12E-01		4200	7.10E-01
4500		3.08E-01	3.11E-01	7.09E-01		4500	7.08E-01
4800		3.05E-01	3.09E-01	7.06E-01		4800	7.06E-01
5100		3.02E-01	3.07E-01	7.04E-01		5100	7.04E-01
5400		2.99E-01	3.06E-01	7.01E-01		5400	7.02E-01
5700		2.96E-01	3.04E-01	6.99E-01		5700	7.00E-01
6000		2.94E-01	3.02E-01	6.96E-01		6000	6.98E-01
6300		2.91E-01	3.01E-01	6.94E-01		6300	6.96E-01

**FLIGHT NO. C-376**  
**EQUIVALENT ATTENUATION LENGTH**

(JOB 2240 DATE 03/C9/77)  
 DATE 50876 FLIGHT NO. C-376 GROUND LEVEL ALTITUDE (M)= 61

ALTITUDE (M)	FILTERS	2	4	3	5
0		1.02E 03	7.58E 02	7.29E 03	4.03E 03
300		1.04E 03	7.69E 02	7.40E 03	4.09E 03
600		1.06E 03	7.82E 02	7.54E 03	4.13E 03
900		1.26E 03	1.00E 03	5.72E 03	4.56E 03
1200		1.55E 03	1.29E 03	5.72E 03	5.13E 03
1500		1.83E 03	1.58E 03	6.31E 03	6.13E 03
1800		2.10E 03	1.84E 03	7.22E 03	7.12E 03
2100		2.28E 03	2.06E 03	8.08E 03	7.90E 03
2400		2.39E 03	2.25E 03	8.75E 03	8.19E 03
2700		2.56E 03	2.45E 03	9.00E 03	8.55E 03
3000		2.75E 03	2.64E 03	9.46E 03	9.10E 03
3300		2.91E 03	2.88E 03	1.01E 04	9.91E 03
3600		3.13E 03	3.12E 03	1.08E 04	1.07E 04
3900		3.36E 03	3.37E 03	1.16E 04	1.15E 04
4200		3.59E 03	3.61E 03	1.24E 04	1.23E 04
4500		3.82E 03	3.85E 03	1.31E 04	1.30E 04
4800		4.04E 03	4.09E 03	1.38E 04	1.38E 04
5100		4.26E 03	4.32E 03	1.45E 04	1.45E 04
5400		4.47E 03	4.56E 03	1.52E 04	1.52E 04
5700		4.69E 03	4.79E 03	1.59E 04	1.60E 04
6000		4.90E 03	5.02E 03	1.66E 04	1.67E 04
6300		5.11E 03	5.24E 03	1.72E 04	1.74E 04

FLIGHT C-377 – 10 MAY 1976 – DESCRIPTION OF FLIGHT AND WEATHER CHARACTERISTICS

Filter Identification	Data Interval			Solar Zenith Angle			Maximum Flight Altitude (meters)	Average Terrain Elevation (meters)
	Start (GMT)	End (GMT)	Elapsed (hrs)	Initial ST & LV (degrees)	Solar Transit (degrees)	Final VPRO (degrees)		
2 and 3	0904	1100	1.9	48.9	—	35.6	6090	60
4 and 5	1109	1253	1.8	35.1	33.2	34.6	6090	60

Flight C-377 was a morning flight extending through local apparent noon. There were multiple cloud layers extending above the maximum flight altitude and widespread haze. The in-flight pictures indicate relatively clear upper hemispheres at the maximum flight altitudes.

The approximate east-west track was located between Bournemouth-Hurn and Yeovilton near the south central coast of England. Typical terrain features were rolling green fields and woods interspersed with occasional brown fields and small towns.

The in-flight observer reported thin overcast cirrus at 7500 meters (25000 feet) early in the flight with scattered cumulus forming at 600 meters (2000 feet) after 0930 GMT. Thin scattered altocumulus at 3600 meters (12000 feet) were present from 0910 to 1110 GMT. The cumulus layer increased after noon and varied from 2/8 to 5/8 coverage with some towering cumulus.

Data reported at Yeovilton, 16 kilometers northwest of the track center point, show 3/8 to 4/8 cirrus at 7500 meters (25000 feet), 1/8 to 2/8 altocumulus at 3600 meters (12000 feet) before noon. In the afternoon there was 1/8 cumulus at 750 meters (2500 feet). Visibility of 7 kilometers in haze gradually improved to 15 kilometers.

Bournemouth-Hurn, 45 kilometers eastsoutheast of the flight track center point, reported scattered cumulus at 1050 meters (3500 feet) throughout the period. At 1300 GMT 5/8 cirrus at 7500 meters (25000 feet) was reported, the layer decreased to 3/8 by 1400 GMT and was not present at 1500 GMT. Visibility was 9 to 14 kilometers.

The radiosonde station at Crawley was 160 kilometers east and downstream from the flight track center point.

The surface charts show that a cold front passed through the southern part of England shortly after 0600 GMT. At 1200 GMT a cold front extended from central Germany southwestward to Gibraltar and into the Atlantic. At 500 millibars there was a trough through Ireland and the Irish Sea at 1200 GMT. This trough produced southsouthwesterly flow over southern England. The airmass was unstable maritime polar.

# FLIGHT NO. C-377

YEOVIL

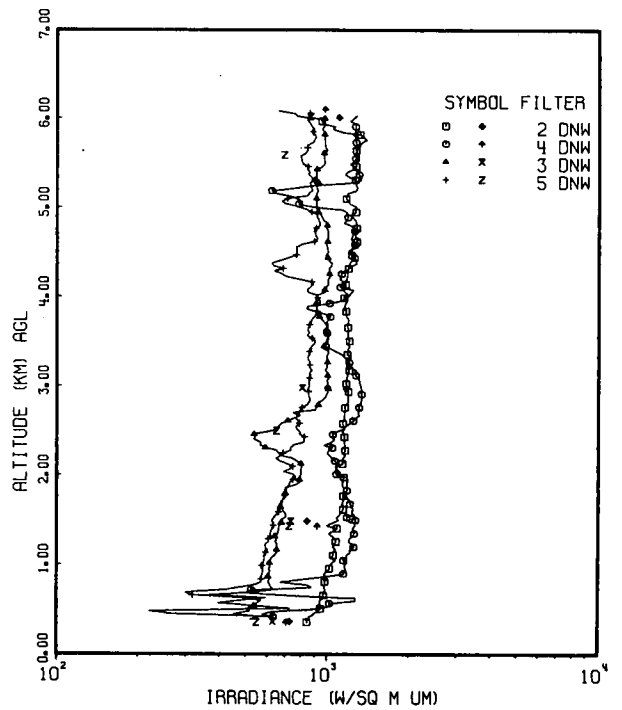
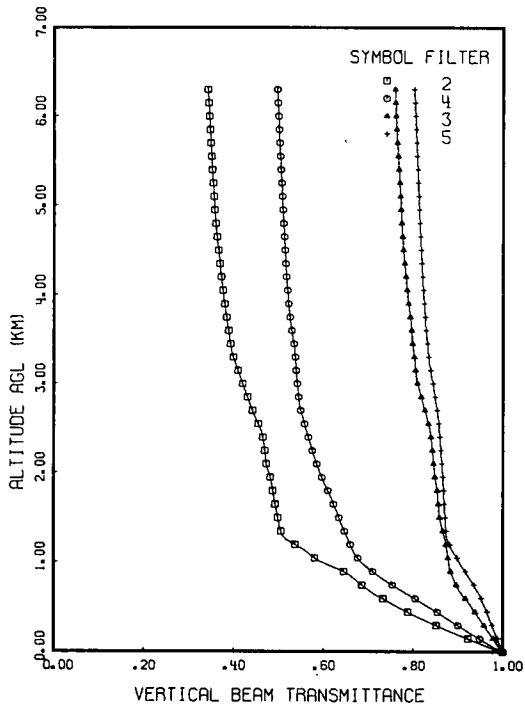
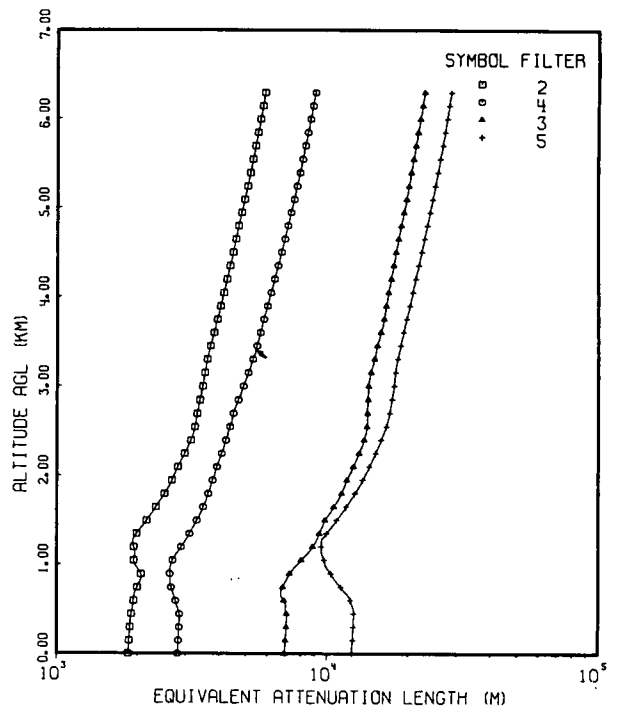
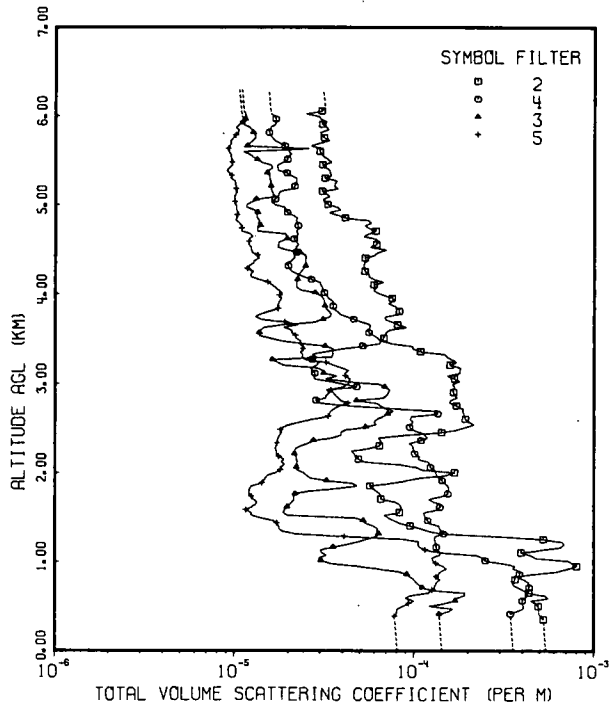

**FLIGHT NO. C-377**  
**TOTAL VOLUME SCATTERING COEFFICIENT**

(JOB 2675 DATE 03/C9/77)  
 DATE 51076 FLIGHT NO. C-377 GROUND LEVEL ALTITUDE (M)= 61

ALTITUDE (M)	TOTAL VOLUME SCATTERING COEFFICIENT (PER M)			
	FILTERS	2	4	3
0	(5.42E-04 )	(3.57E-04 )	(1.43E-04 )	(8.10E-05 )
30	(5.40E-04 )	(3.55E-04 )	(1.43E-04 )	(8.06E-05 )
60	(5.38E-04 )	(3.55E-04 )	(1.42E-04 )	(8.04E-05 )
90	(5.37E-04 )	(3.54E-04 )	(1.42E-04 )	(8.02E-05 )
120	(5.36E-04 )	(3.53E-04 )	(1.42E-04 )	(8.00E-05 )
150	(5.34E-04 )	(3.52E-04 )	(1.41E-04 )	(7.98E-05 )
180	(5.33E-04 )	(3.51E-04 )	(1.41E-04 )	(7.96E-05 )
210	(5.32E-04 )	(3.50E-04 )	(1.41E-04 )	(7.94E-05 )
240	(5.30E-04 )	(3.49E-04 )	(1.40E-04 )	(7.92E-05 )
270	(5.29E-04 )	(3.48E-04 )	(1.40E-04 )	(7.90E-05 )
300	(5.27E-04 )	(3.47E-04 )	(1.39E-04 )	(7.88E-05 )
330	(5.26E-04 )	(3.46E-04 )	(1.39E-04 )	(7.86E-05 )
360	5.25E-04	(3.45E-04 )	(1.39E-04 )	(7.84E-05 )
390	5.14E-04	(3.45E-04 )	(1.38E-04 )	7.82E-05
420	4.96E-04	3.44E-04	1.38E-04	8.00E-05
450	4.93E-04	3.70E-04	1.57E-04	8.04E-05
480	4.95E-04	4.03E-04	1.64E-04	8.11E-05
510	4.92E-04	4.09E-04	1.21E-04	8.68E-05
540	4.77E-04	3.98E-04	1.48E-04	9.35E-05
570	4.44E-04	4.01E-04	1.70E-04	1.00E-04
600	5.58E-04	4.12E-04	1.74E-04	8.97E-05
630	5.32E-04	4.26E-04	1.90E-04	9.63E-05
660	4.35E-04	4.28E-04	1.92E-04	1.21E-04
690	4.04E-04	4.34E-04	1.25E-04	1.26E-04
720	3.81E-04	4.37E-04	1.11E-04	1.30E-04
750	3.56E-04	4.37E-04	1.07E-04	1.32E-04
780	3.52E-04	4.33E-04	1.02E-04	1.34E-04
810	3.64E-04	4.06E-04	9.97E-05	1.39E-04
840	3.62E-04	3.78E-04	9.47E-05	1.32E-04
870	4.56E-04	3.85E-04	9.11E-05	1.37E-04
900	6.27E-04	3.93E-04	8.10E-05	1.41E-04
930	7.15E-04	3.55E-04	6.21E-05	1.51E-04
960	8.02E-04	3.66E-04	4.83E-05	1.45E-04
990	7.63E-04	3.14E-04	3.41E-05	1.32E-04
1020	7.17E-04	2.49E-04	3.03E-05	1.27E-04
1050	4.71E-04	2.42E-04	2.95E-05	1.26E-04
1080	4.45E-04	2.23E-04	3.26E-05	1.38E-04
1110	3.93E-04	1.40E-04	3.05E-05	1.40E-04
1140	5.12E-04	1.32E-04	3.02E-05	1.15E-04
1170	6.55E-04	1.33E-04	3.54E-05	1.07E-04
1200	6.87E-04	1.33E-04	4.24E-05	1.05E-04
1230	6.66E-04	1.31E-04	4.89E-05	1.06E-04
1260	5.23E-04	1.29E-04	5.50E-05	8.76E-05
1290	3.00E-04	1.31E-04	6.19E-05	4.07E-05
1320	1.47E-04	1.46E-04	6.34E-05	2.15E-05
1350	1.19E-04	1.41E-04	6.22E-05	1.83E-05
1380	1.08E-04	1.39E-04	6.26E-05	1.77E-05
1410	9.50E-05	1.37E-04	5.91E-05	1.76E-05
1440	8.25E-05	1.21E-04	5.38E-05	1.72E-05
1470	7.70E-05	1.19E-04	5.21E-05	1.63E-05
1500	7.16E-05	1.15E-04	4.67E-05	1.39E-05

**FLIGHT NO. C-377**  
**TOTAL VOLUME SCATTERING COEFFICIENT**

(JOB 2675 DATE 03/C9/77)  
 DATE 51076 FLIGHT NO. C-377 GROUND LEVEL ALTITUDE (M)= 61

ALTITUDE (M)	FILTERS	TOTAL VOLUME SCATTERING COEFFICIENT (PER M)			
		2	4	3	5
1530	6.83E-05	1.14E-04	1.94E-05	1.24E-05	
1560	8.30E-05	1.13E-04	1.86E-05	1.24E-05	
1590	8.39E-05	1.35E-04	1.90E-05	1.16E-05	
1620	8.48E-05	1.39E-04	1.96E-05	1.23E-05	
1650	8.29E-05	1.43E-04	2.02E-05	1.31E-05	
1680	7.80E-05	1.27E-04	2.10E-05	1.33E-05	
1710	6.54E-05	1.20E-04	2.14E-05	1.27E-05	
1740	6.61E-05	1.42E-04	2.12E-05	1.24E-05	
1770	6.45E-05	1.54E-04	2.18E-05	1.20E-05	
1800	6.15E-05	1.54E-04	2.58E-05	1.21E-05	
1830	5.85E-05	1.56E-04	3.71E-05	1.21E-05	
1860	5.68E-05	1.54E-04	4.80E-05	1.25E-05	
1890	7.45E-05	1.47E-04	4.48E-05	1.43E-05	
1920	9.09E-05	1.43E-04	3.26E-05	1.46E-05	
1950	1.07E-04	1.38E-04	2.61E-05	1.49E-05	
1980	1.51E-04	1.33E-04	2.51E-05	1.53E-05	
2010	1.68E-04	1.32E-04	2.41E-05	1.71E-05	
2040	1.10E-04	1.30E-04	2.23E-05	1.80E-05	
2070	1.03E-04	1.23E-04	2.21E-05	1.81E-05	
2100	8.37E-05	1.24E-04	2.24E-05	1.89E-05	
2130	5.28E-05	1.20E-04	2.23E-05	1.83E-05	
2160	4.89E-05	1.05E-04	2.21E-05	1.89E-05	
2190	4.70E-05	1.07E-04	2.19E-05	1.76E-05	
2220	4.62E-05	1.01E-04	2.16E-05	1.70E-05	
2250	4.48E-05	1.01E-04	2.17E-05	1.71E-05	
2280	5.57E-05	9.82E-05	2.18E-05	1.69E-05	
2310	6.41E-05	9.80E-05	2.34E-05	1.70E-05	
2340	6.59E-05	9.33E-05	2.58E-05	1.72E-05	
2370	6.49E-05	1.09E-04	2.74E-05	1.73E-05	
2400	6.29E-05	1.18E-04	3.49E-05	1.76E-05	
2430	8.73E-05	1.15E-04	3.90E-05	1.78E-05	
2460	1.42E-04	1.09E-04	3.91E-05	1.83E-05	
2490	1.74E-04	9.76E-05	4.11E-05	1.80E-05	
2520	1.94E-04	9.41E-05	5.35E-05	1.86E-05	
2550	2.14E-04	9.57E-05	6.13E-05	2.03E-05	
2580	2.01E-04	9.79E-05	5.97E-05	2.34E-05	
2610	1.92E-04	9.44E-05	6.21E-05	2.72E-05	
2640	1.91E-04	9.66E-05	6.69E-05	3.32E-05	
2670	1.89E-04	1.35E-04	7.12E-05	3.37E-05	
2700	1.86E-04	1.33E-04	7.63E-05	3.42E-05	
2730	1.87E-04	7.73E-05	6.95E-05	3.61E-05	
2760	1.71E-04	4.39E-05	6.54E-05	3.82E-05	
2790	1.58E-04	2.99E-05	6.13E-05	4.26E-05	
2820	1.58E-04	2.83E-05	4.77E-05	3.88E-05	
2850	1.73E-04	3.20E-05	6.76E-05	3.77E-05	
2880	1.66E-04	3.23E-05	7.07E-05	3.62E-05	
2910	1.65E-04	3.39E-05	7.18E-05	3.53E-05	
2940	1.64E-04	3.23E-05	7.29E-05	3.44E-05	
2970	1.67E-04	4.77E-05	6.84E-05	3.98E-05	
3000	1.62E-04	4.10E-05	6.40E-05	4.24E-05	

**FLIGHT NO. C-377**  
**TOTAL VOLUME SCATTERING COEFFICIENT**

(JOB 2675 DATE 03/C9/77)  
 DATE 51076 FLIGHT NO. C-377 GROUND LEVEL ALTITUDE (M)= 61

ALTITUDE (M)	FILTERS	TOTAL VOLUME SCATTERING COEFFICIENT (PER M)			
		2	4	3	5
3030	1.78E-04	3.44E-05	4.26E-05	4.35E-05	
3060	1.67E-04	2.77E-05	3.21E-05	4.39E-05	
3090	1.52E-04	2.78E-05	3.69E-05	4.13E-05	
3120	1.79E-04	2.78E-05	3.13E-05	4.09E-05	
3150	1.80E-04	2.71E-05	3.10E-05	4.32E-05	
3180	1.81E-04	2.66E-05	2.84E-05	3.92E-05	
3210	1.58E-04	2.87E-05	1.85E-05	3.55E-05	
3240	1.71E-04	2.93E-05	1.73E-05	3.21E-05	
3270	1.62E-04	2.69E-05	1.62E-05	2.49E-05	
3300	1.52E-04	2.85E-05	3.48E-05	2.36E-05	
3330	1.47E-04	2.69E-05	3.51E-05	2.39E-05	
3360	1.08E-04	3.23E-05	3.52E-05	2.33E-05	
3390	9.78E-05	3.89E-05	3.53E-05	2.40E-05	
3420	9.76E-05	5.16E-05	3.18E-05	2.38E-05	
3450	7.41E-05	6.42E-05	2.37E-05	2.29E-05	
3480	6.54E-05	6.48E-05	1.81E-05	2.33E-05	
3510	6.74E-05	6.25E-05	1.56E-05	2.19E-05	
3540	6.86E-05	5.95E-05	1.37E-05	2.18E-05	
3570	6.93E-05	5.58E-05	1.37E-05	2.07E-05	
3600	7.24E-05	5.48E-05	1.40E-05	2.08E-05	
3630	8.98E-05	5.65E-05	1.45E-05	1.87E-05	
3660	8.03E-05	5.66E-05	1.84E-05	2.24E-05	
3690	7.48E-05	5.06E-05	2.81E-05	1.89E-05	
3720	6.87E-05	4.58E-05	3.10E-05	1.40E-05	
3750	6.88E-05	4.20E-05	3.39E-05	1.30E-05	
3780	8.28E-05	3.82E-05	3.44E-05	1.39E-05	
3810	8.22E-05	3.70E-05	3.35E-05	1.54E-05	
3840	8.15E-05	3.51E-05	3.23E-05	1.75E-05	
3870	7.73E-05	3.52E-05	3.18E-05	1.72E-05	
3900	7.14E-05	3.55E-05	3.15E-05	1.75E-05	
3930	7.74E-05	3.49E-05	3.14E-05	1.78E-05	
3960	7.49E-05	3.30E-05	3.09E-05	1.83E-05	
3990	6.79E-05	3.24E-05	2.99E-05	1.77E-05	
4020	6.20E-05	3.14E-05	2.81E-05	1.83E-05	
4050	5.90E-05	3.10E-05	2.34E-05	1.76E-05	
4080	6.09E-05	3.06E-05	2.20E-05	1.69E-05	
4110	5.94E-05	3.00E-05	2.20E-05	1.60E-05	
4140	6.71E-05	2.98E-05	2.20E-05	1.52E-05	
4170	5.98E-05	2.66E-05	2.23E-05	1.36E-05	
4200	5.57E-05	2.42E-05	2.26E-05	1.23E-05	
4230	5.57E-05	2.23E-05	2.29E-05	1.22E-05	
4260	5.28E-05	2.07E-05	2.33E-05	1.27E-05	
4290	5.24E-05	2.01E-05	2.40E-05	1.17E-05	
4320	5.21E-05	1.98E-05	2.48E-05	1.20E-05	
4350	5.25E-05	1.94E-05	2.50E-05	1.27E-05	
4380	5.43E-05	2.06E-05	2.47E-05	1.28E-05	
4410	5.31E-05	2.14E-05	2.47E-05	1.36E-05	
4440	5.99E-05	2.13E-05	2.49E-05	1.34E-05	
4470	6.28E-05	2.20E-05	2.30E-05	1.25E-05	
4500	6.96E-05	2.24E-05	1.92E-05	1.24E-05	

**FLIGHT NO. C-377**  
**TOTAL VOLUME SCATTERING COEFFICIENT**

(JOB 2675 DATE 03/C9/77)  
 DATE 51076 FLIGHT NO. C-377 GROUND LEVEL ALTITUDE (M)= 61

ALTITUDE (M)	FILTERS	TOTAL VOLUME SCATTERING COEFFICIENT (PER M)			
		2	4	3	5
4530		5.69E-05	2.17E-05	1.73E-05	1.23E-05
4560		6.12E-05	2.26E-05	1.75E-05	1.19E-05
4590		6.35E-05	2.20E-05	1.77E-05	1.20E-05
4620		6.11E-05	2.13E-05	1.96E-05	1.20E-05
4650		5.18E-05	2.20E-05	1.94E-05	1.26E-05
4680		5.57E-05	2.24E-05	1.92E-05	1.22E-05
4710		6.08E-05	2.19E-05	1.33E-05	1.09E-05
4740		5.57E-05	2.27E-05	1.33E-05	1.09E-05
4770		5.26E-05	2.25E-05	1.39E-05	1.09E-05
4800		5.75E-05	2.21E-05	1.35E-05	1.06E-05
4830		5.50E-05	2.19E-05	1.36E-05	1.01E-05
4860		4.10E-05	2.22E-05	1.33E-05	1.02E-05
4890		3.71E-05	2.09E-05	1.31E-05	1.03E-05
4920		3.32E-05	1.95E-05	1.34E-05	1.05E-05
4950		3.86E-05	1.88E-05	1.28E-05	1.02E-05
4980		3.71E-05	1.88E-05	1.15E-05	1.02E-05
5010		3.28E-05	1.66E-05	1.17E-05	1.01E-05
5040		3.13E-05	1.59E-05	1.25E-05	9.98E-06
5070		3.09E-05	1.67E-05	1.31E-05	1.00E-05
5100		3.36E-05	1.73E-05	1.66E-05	9.90E-06
5130		3.21E-05	1.75E-05	1.63E-05	1.01E-05
5160		3.06E-05	1.77E-05	1.61E-05	1.03E-05
5190		3.72E-05	2.10E-05	1.59E-05	1.01E-05
5220		3.55E-05	2.15E-05	1.58E-05	1.01E-05
5250		3.62E-05	2.20E-05	1.58E-05	1.01E-05
5280		3.69E-05	2.20E-05	1.58E-05	1.00E-05
5310		3.16E-05	2.19E-05	1.55E-05	9.44E-06
5340		3.44E-05	2.04E-05	1.55E-05	9.61E-06
5370		3.37E-05	1.94E-05	1.51E-05	9.22E-06
5400		3.35E-05	1.74E-05	1.54E-05	9.02E-06
5430		3.20E-05	1.73E-05	1.62E-05	9.37E-06
5460		3.06E-05	1.72E-05	1.59E-05	9.72E-06
5490		3.44E-05	1.84E-05	1.41E-05	9.62E-06
5520		3.28E-05	1.96E-05	1.33E-05	9.58E-06
5550		3.13E-05	1.97E-05	1.25E-05	9.53E-06
5580		3.03E-05	2.05E-05	1.20E-05	9.49E-06
5610		2.96E-05	2.00E-05	1.11E-05	9.25E-06
5640		3.02E-05	1.96E-05	2.58E-05	9.16E-06
5670		2.65E-05	1.89E-05	1.17E-05	9.36E-06
5700		2.95E-05	1.78E-05	1.21E-05	9.56E-06
5730		3.36E-05	1.67E-05	1.25E-05	9.46E-06
5760		3.13E-05	1.62E-05	1.29E-05	9.77E-06
5790		3.05E-05	1.57E-05	1.29E-05	1.01E-05
5820		2.97E-05	1.55E-05	1.26E-05	1.04E-05
5850		3.31E-05	1.55E-05	1.25E-05	1.06E-05
5880		3.24E-05	1.58E-05	1.20E-05	1.01E-05
5910		3.05E-05	1.67E-05	1.12E-05	1.06E-05
5940		3.24E-05	1.70E-05	1.13E-05	1.10E-05
5970		2.98E-05	1.68E-05	1.14E-05	1.14E-05
6000		2.96E-05	1.67E-05	1.09E-05	1.16E-05
6030		2.47E-05	1.58E-05	(1.09E-05 )	1.14E-05
6060		3.03E-05	(1.58E-05 )	(1.08E-05 )	1.12E-05
6090		3.17E-05	(1.57E-05 )	(1.08E-05 )	(1.12E-05 )
6120	(3.16E-05 )	(1.57E-05 )	(1.08E-05 )	(1.11E-05 )	(1.11E-05 )
6150	(3.15E-05 )	(1.56E-05 )	(1.07E-05 )	(1.11E-05 )	(1.11E-05 )
6180	(3.14E-05 )	(1.56E-05 )	(1.07E-05 )	(1.11E-05 )	(1.11E-05 )
6210	(3.13E-05 )	(1.55E-05 )	(1.07E-05 )	(1.10E-05 )	(1.10E-05 )
6240	(3.12E-05 )	(1.55E-05 )	(1.06E-05 )	(1.10E-05 )	(1.10E-05 )
6270	(3.11E-05 )	(1.54E-05 )	(1.06E-05 )	(1.10E-05 )	(1.10E-05 )
6300	(3.10E-05 )	(1.54E-05 )	(1.06E-05 )	(1.09E-05 )	(1.09E-05 )
FIRST DATA ALT	360	420	420	390	
LAST DATA ALT	6090	6030	6000	6060	

**FLIGHT NO. C-377**  
**VERTICAL BEAM TRANSMITTANCE FROM GROUND TO ALTITUDE**

ALTITUDE (M)	VERTICAL BEAM FILTERS	2	4	3	5
0		1.00E 00	1.00E 00	1.00E 00	1.00E 00
300		8.52E-01	5.00E-01	9.58E-01	9.76E-01
600		7.33E-01	8.04E-01	9.17E-01	9.52E-01
900		6.46E-01	7.10E-01	8.84E-01	9.17E-01
1200		5.37E-01	6.60E-01	8.73E-01	8.81E-01
1500		4.98E-01	6.35E-01	8.59E-01	8.71E-01
1800		4.87E-01	6.10E-01	8.53E-01	8.68E-01
2100		4.73E-01	5.85E-01	8.45E-01	8.64E-01
2400		4.65E-01	5.67E-01	8.39E-01	8.59E-01
2700		4.42E-01	5.49E-01	8.25E-01	8.53E-01
3000		4.20E-01	5.42E-01	8.09E-01	8.43E-01
3300		4.00E-01	5.37E-01	8.02E-01	8.34E-01
3600		3.89E-01	5.29E-01	7.96E-01	8.28E-01
3900		3.80E-01	5.22E-01	7.89E-01	8.24E-01
4200		3.72E-01	5.17E-01	7.83E-01	8.20E-01
4500		3.66E-01	5.14E-01	7.78E-01	8.17E-01
4800		3.60E-01	5.11E-01	7.74E-01	8.14E-01
5100		3.56E-01	5.08E-01	7.71E-01	8.11E-01
5400		3.52E-01	5.05E-01	7.67E-01	8.09E-01
5700		3.49E-01	5.02E-01	7.64E-01	8.07E-01
6000		3.46E-01	4.99E-01	7.61E-01	8.04E-01
6300		3.43E-01	4.97E-01	7.58E-01	8.02E-01

**FLIGHT NO. C-377**  
**EQUIVALENT ATTENUATION LENGTH**

(JOB 2675 DATE 03/C9/77)  
 DATE 51076 FLIGHT NO. C-377 GROUND LEVEL ALTITUDE (M)= 61

ALTITUDE (M)	FILTERS	2	4	3	5
0		1.84E 03	2.80E 03	6.97E 03	1.23E 04
300		1.87E 03	2.84E 03	7.08E 03	1.25E 04
600		1.93E 03	2.76E 03	6.93E 03	1.22E 04
900		2.06E 03	2.63E 03	7.27E 03	1.03E 04
1200		1.93E 03	2.89E 03	8.85E 03	9.51E 03
1500		2.15E 03	3.30E 03	9.84E 03	1.08E 04
1800		2.51E 03	3.64E 03	1.13E 04	1.27E 04
2100		2.81E 03	3.92E 03	1.25E 04	1.43E 04
2400		3.14E 03	4.23E 03	1.37E 04	1.58E 04
2700		3.31E 03	4.50E 03	1.41E 04	1.70E 04
3000		3.46E 03	4.89E 03	1.42E 04	1.76E 04
3300		3.60E 03	5.31E 03	1.49E 04	1.82E 04
3600		3.81E 03	5.65E 03	1.58E 04	1.91E 04
3900		4.03E 03	6.00E 03	1.65E 04	2.01E 04
4200		4.25E 03	6.37E 03	1.72E 04	2.12E 04
4500		4.48E 03	6.76E 03	1.79E 04	2.22E 04
4800		4.70E 03	7.14E 03	1.87E 04	2.33E 04
5100		4.94E 03	7.52E 03	1.96E 04	2.44E 04
5400		5.17E 03	7.89E 03	2.04E 04	2.55E 04
5700		5.41E 03	8.27E 03	2.11E 04	2.65E 04
6000		5.65E 03	8.64E 03	2.20E 04	2.75E 04
6300		5.88E 03	9.01E 03	2.28E 04	2.85E 04

FLIGHT C-378 – 12 MAY 1976 – DESCRIPTION OF FLIGHT AND WEATHER CHARACTERISTICS

Filter Identification	Data Interval			Solar Zenith Angle			Maximum Flight Altitude (meters)	Average Terrain Elevation (meters)
	Start (GMT)	End (GMT)	Elapsed (hrs)	Initial ST&LV (degrees)	Solar Transit (degrees)	Final VPRO (degrees)		
2 and 3	0944	1025	0.7	40.1	—	37.5		0
4 and 5	1032	1118	0.8	37.2	36.5	36.5	1590	0

Flight C-378 was a morning flight extending slightly beyond local apparent noon. It was thinly overcast with multiple cloud layers.

The approximate southeast to northwest track was located south of Lolland Island, Denmark. Typical terrain features along the nearby coast north of the track were flat cultivated farmlands interspersed with occasional woods and small towns. Directly beneath the track and to the south were the relatively shallow waters of Femer Bay.

The in-flight observer reported 6/8 to 7/8 altocumulus clouds at 1800 meters (6000 feet), another layer at 2700 meters (9000 feet) and cirrus clouds at 7500 meters (25 000 feet).

At Fehrmanbelt, 10 kilometers south of the track center point, no clouds were reported on the three-hourly observations at 0900 and 1200 GMT.

Kegnaes, 80 kilometers westnorthwest of the track center point, reported 5/8 cumulus at 840 meters (2800 feet) at 0900 GMT and 6/8 stratus at 540 meters (1800 feet) and overcast altostratus at 1350 meters (4500 feet) at 1200 GMT. This station also reported visibility of 10 to 12 kilometers.

The radiosonde station at Schleswig was 106 kilometers west and upstream from the flight track center point.

The surface chart for 1200 GMT shows a low in the North Sea. A cold front, part of this system, extended southwestward through the English channel. At 500 millibars the flight area was in transitional area from ridge to trough with moderate southwesterly winds. The airmass was stable maritime polar.

# FLIGHT NO. C-378

RODBY

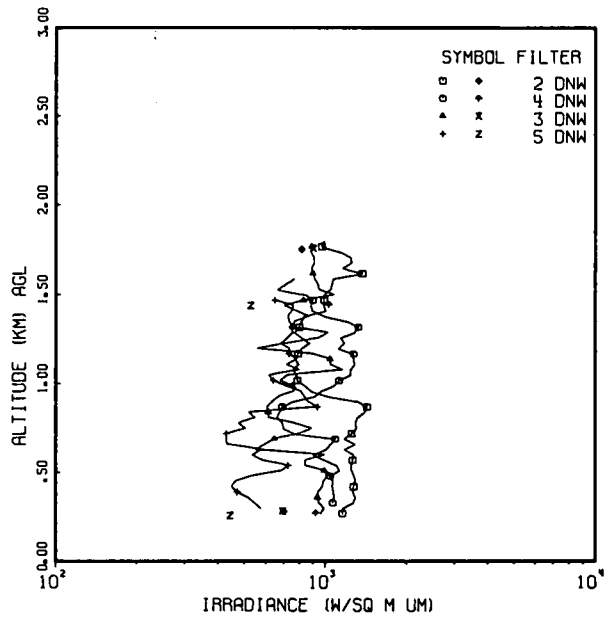
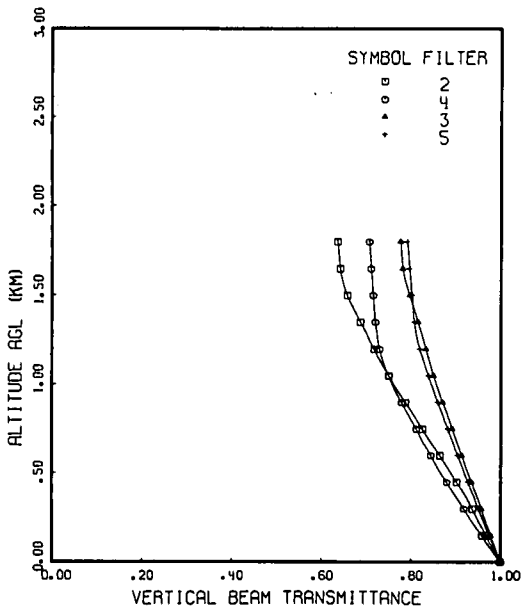
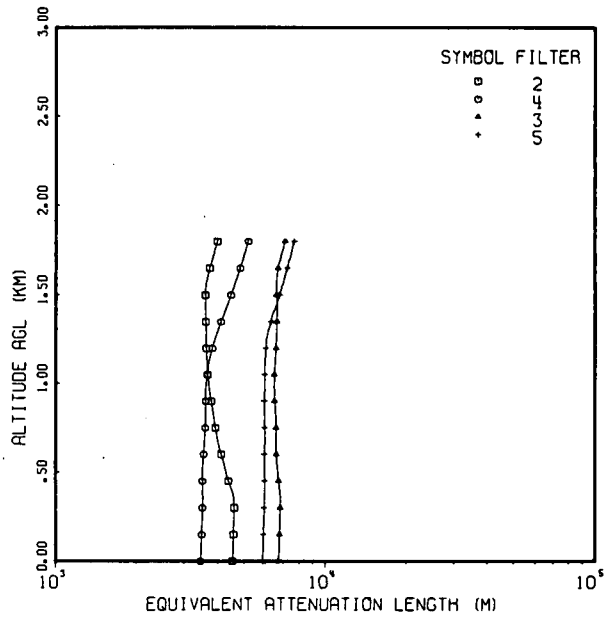
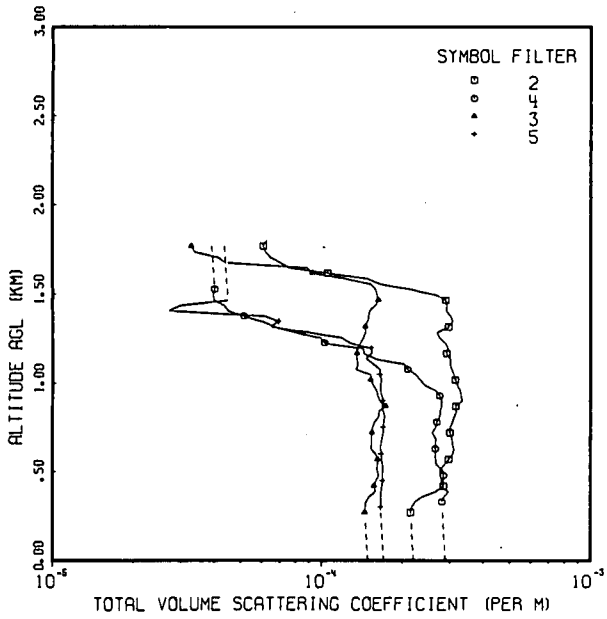

# FLIGHT NO. C-378

## TOTAL VOLUME SCATTERING COEFFICIENT

(JOB 2679 DATE 03/C9/77)  
 DATE 51276 FLIGHT NO. C-378 GROUND LEVEL ALTITUDE (M)= 0

ALTITUDE (M)	TOTAL VOLUME SCATTERING COEFFICIENT (PER M)			
	FILTERS	2	4	3
0	(2.20E-04 )	(2.89E-04 )	(1.49E-04 )	(1.71E-04 )
30	(2.19E-04 )	(2.88E-04 )	(1.48E-04 )	(1.70E-04 )
60	(2.19E-04 )	(2.87E-04 )	(1.48E-04 )	(1.69E-04 )
90	(2.18E-04 )	(2.87E-04 )	(1.47E-04 )	(1.69E-04 )
120	(2.18E-04 )	(2.86E-04 )	(1.47E-04 )	(1.68E-04 )
150	(2.17E-04 )	(2.85E-04 )	(1.47E-04 )	(1.68E-04 )
180	(2.16E-04 )	(2.84E-04 )	(1.46E-04 )	(1.68E-04 )
210	(2.16E-04 )	(2.84E-04 )	(1.46E-04 )	(1.67E-04 )
240	(2.15E-04 )	(2.83E-04 )	(1.46E-04 )	(1.67E-04 )
270	2.15E-04	(2.82E-04 )	1.45E-04	(1.66E-04 )
300	2.17E-04	(2.81E-04 )	1.45E-04	1.66E-04
330	2.23E-04	2.81E-04	1.46E-04	1.66E-04
360	2.37E-04	2.87E-04	1.50E-04	1.66E-04
390	2.67E-04	2.98E-04	1.59E-04	1.67E-04
420	2.85E-04	2.75E-04	1.57E-04	1.68E-04
450	2.81E-04	2.84E-04	1.60E-04	1.69E-04
480	2.76E-04	2.85E-04	1.63E-04	1.69E-04
510	2.76E-04	2.82E-04	1.61E-04	1.69E-04
540	2.86E-04	2.67E-04	1.62E-04	1.68E-04
570	2.98E-04	2.66E-04	1.62E-04	1.67E-04
600	3.08E-04	2.64E-04	1.59E-04	1.67E-04
630	3.11E-04	2.65E-04	1.53E-04	1.66E-04
660	3.07E-04	2.66E-04	1.53E-04	1.66E-04
690	3.05E-04	2.66E-04	1.53E-04	1.68E-04
720	3.00E-04	2.58E-04	1.54E-04	1.70E-04
750	3.02E-04	2.66E-04	1.55E-04	1.70E-04
780	3.07E-04	2.69E-04	1.57E-04	1.71E-04
810	3.12E-04	2.75E-04	1.63E-04	1.72E-04
840	3.18E-04	2.77E-04	1.63E-04	1.70E-04
870	3.16E-04	2.79E-04	1.73E-04	1.67E-04
900	3.34E-04	2.81E-04	1.65E-04	1.69E-04
930	3.31E-04	2.75E-04	1.62E-04	1.67E-04
960	3.28E-04	2.66E-04	1.60E-04	1.65E-04
990	3.20E-04	2.42E-04	1.56E-04	1.65E-04
1020	3.15E-04	2.33E-04	1.52E-04	1.67E-04
1050	3.11E-04	2.24E-04	1.52E-04	1.65E-04
1080	3.05E-04	2.09E-04	1.34E-04	1.65E-04
1110	3.01E-04	2.03E-04	1.36E-04	1.56E-04
1140	3.01E-04	1.58E-04	1.35E-04	1.47E-04
1170	2.92E-04	1.44E-04	1.35E-04	1.54E-04
1200	2.96E-04	1.42E-04	1.36E-04	1.53E-04
1230	2.89E-04	1.03E-04	1.39E-04	1.27E-04
1260	2.74E-04	9.90E-05	1.43E-04	1.18E-04
1290	2.69E-04	8.00E-05	1.46E-04	9.00E-05
1320	2.97E-04	6.72E-05	1.45E-04	6.50E-05
1350	3.07E-04	6.04E-05	1.49E-04	6.91E-05
1380	3.01E-04	5.15E-05	1.50E-04	6.15E-05
1410	2.91E-04	4.49E-05	1.51E-04	2.71E-05
1440	2.92E-04	4.35E-05	1.59E-04	3.00E-05
1470	2.89E-04	3.99E-05	1.63E-04	4.48E-05
1500	2.67E-04	3.95E-05	1.60E-04	(4.47E-05 )
1530	2.18E-04	4.00E-05	1.59E-04	(4.45E-05 )
1560	1.64E-04	(3.99E-05 )	1.52E-04	(4.44E-05 )
1590	1.47E-04	(3.98E-05 )	1.23E-04	(4.43E-05 )
1620	1.05E-04	(3.96E-05 )	9.25E-05	(4.41E-05 )
1650	7.56E-05	(3.95E-05 )	8.84E-05	(4.40E-05 )
1680	7.00E-05	(3.94E-05 )	4.37E-05	(4.39E-05 )
1710	6.42E-05	(3.93E-05 )	4.09E-05	(4.37E-05 )
1740	6.16E-05	(3.92E-05 )	3.37E-05	(4.36E-05 )
1770	6.07E-05	(3.90E-05 )	3.28E-05	(4.35E-05 )
1800	6.26E-05	(3.89E-05 )	(3.27E-05 )	(4.33E-05 )

FIRST DATA ALT      270                      330                      270                      300  
 LAST DATA ALT      1800                      1530                      1770                      1470

**FLIGHT NO. C-378**  
**VERTICAL BEAM TRANSMITTANCE FROM GROUND TO ALTITUDE**

ALTITUDE (M)	VERTICAL BEAM TRANSMITTANCE FROM GROUND TO ALTITUDE			
	FILTERS	2	4	3
0	1.00E 00	1.00E 00	1.00E 00	1.00E 00
300	9.37E-01	9.18E-01	9.57E-01	9.51E-01
600	8.64E-01	8.44E-01	9.13E-01	9.04E-01
900	7.88E-01	7.79E-01	8.70E-01	8.60E-01
1200	7.17E-01	7.30E-01	8.33E-01	8.19E-01
1500	6.58E-01	7.15E-01	7.96E-01	8.01E-01
1800	6.36E-01	7.06E-01	7.76E-01	7.91E-01

**FLIGHT NO. C-378**  
**EQUIVALENT ATTENUATION LENGTH**

(JOB 2679 DATE 03/09/77).  
 DATE 51276 FLIGHT NO. C-378 GROUND LEVEL ALTITUDE (M)= 0

ALTITUDE (M)	EQUIVALENT ATTENUATION LENGTH (M)			
	FILTERS	2	4	3
0	4.54E 03	3.45E 03	6.72E 03	5.86E 03
300	4.61E 03	3.51E 03	6.82E 03	5.95E 03
600	4.11E 03	3.54E 03	6.58E 03	5.96E 03
900	3.77E 03	3.60E 03	6.49E 03	5.95E 03
1200	3.61E 03	3.81E 03	6.56E 03	6.01E 03
1500	3.58E 03	4.47E 03	6.59E 03	6.77E 03
1800	3.97E 03	5.18E 03	7.10E 03	7.67E 03

FLIGHT C-379 – 17 MAY 1976 – DESCRIPTION OF FLIGHT AND WEATHER CHARACTERISTICS

Identification	Start (GMT)	End (GMT)	Elapsed (hrs)	Initial ST&LV (degrees)	Solar Transit (degrees)	Final VPRO (degrees)	Maximum Flight Altitude (meters)	Average Terrain Elevation (meters)
2 and 3	0957	1138	1.7	38.0	35.3	35.7	6270	0
4 and 5	1143	1332	1.8	35.8	–	44.3	6270	0

Flight C-379 was a midday flight spanning local apparent noon. Nearby areas reported clear skies during the morning, with thin cirrus and scattered cumulus developing in the afternoon, although the in-flight pictures indicated clear skies along the track throughout the flight.

The approximate southeast to northwest track was located south of Lolland Island, Denmark. Typical terrain features along the nearby coast to the north of the track was flat cultivated farmlands interspersed with occasional woods and small towns. Directly beneath the track and to the south were the relatively shallow waters of Femer Bay.

The in-flight observer reported clear skies early in the flight with some scattered high thin cirrus beginning at 1045 GMT and increasing to 4/8 at 7500 meters (25 000 feet) by 1145 GMT. Scattered cumulus (1/8) formed at 1200 meters (4000 feet) after 1200 GMT.

At Fehrmanbelt, 10 kilometers south of the track center point, no clouds were reported on the three-hourly observations. Visibility was reported as 20 kilometers.

Kegnaes, 80 kilometers westnorthwest of the track center point, reported 1/8 of cirrus at 6000 meters (20 000 feet) on the 1200 and 1500 GMT observations. Visibility was reported from 15 to 30 kilometers.

The radiosonde station at Schleswig was 106 kilometers west and downstream from the flight track center point.

The surface chart for 1200 GMT shows a closed high cell centered near Kiel Bay. A cold front was moving from Ireland to Britain through the Irish Sea. At 500 millibars there was weak ridging from Sardinia to Sweden with light northwesterly winds. The airmass was stable maritime polar.

# FLIGHT NO. C-379

RODBY

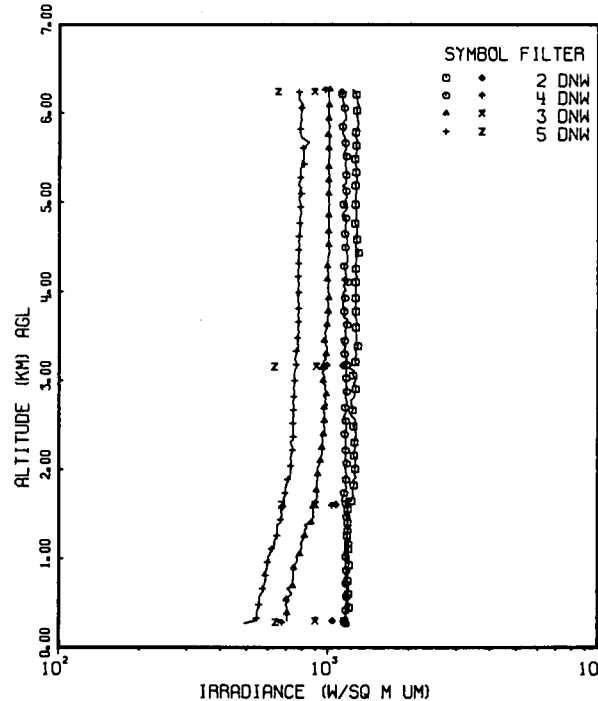
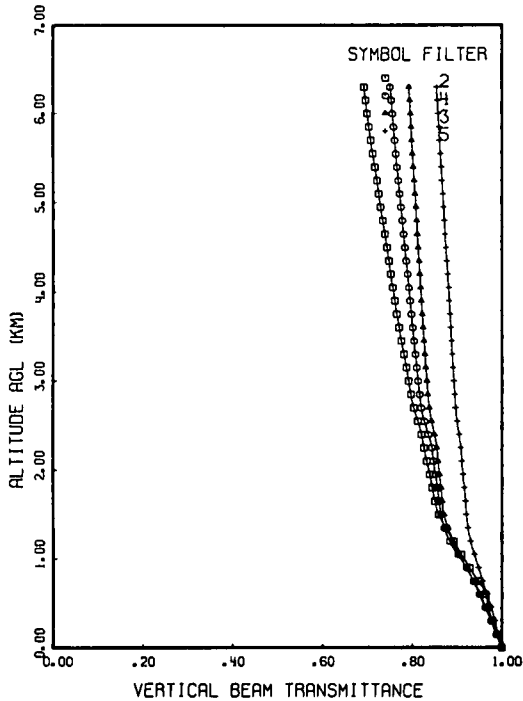
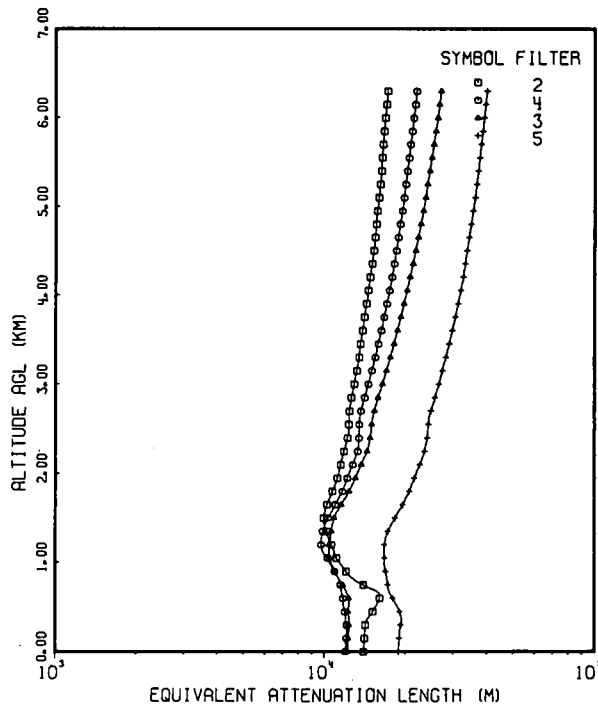
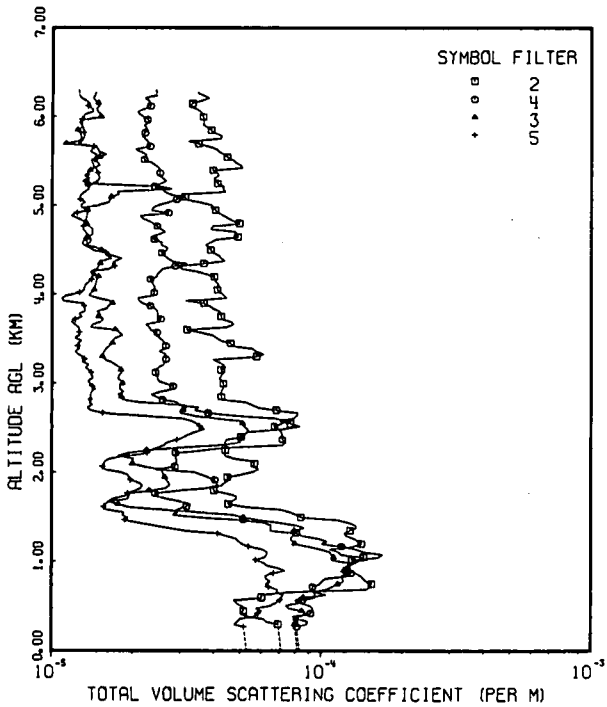

**FLIGHT NO. C-379**  
**TOTAL VOLUME SCATTERING COEFFICIENT**

(JOB 2678 DATE 03/09/77)  
 DATE 51776 FLIGHT NO. C-379 GROUND LEVEL ALTITUDE (M)= 0

ALTITUDE (M)	TOTAL VOLUME SCATTERING COEFFICIENT (PER M)			
	FILTERS	2	4	3
0	(7.14E-05 )	(8.35E-05 )	(8.21E-05 )	(5.31E-05 )
30	(7.10E-05 )	(8.30E-05 )	(8.17E-05 )	(5.28E-05 )
60	(7.09E-05 )	(8.28E-05 )	(8.15E-05 )	(5.27E-05 )
90	(7.07E-05 )	(8.26E-05 )	(8.13E-05 )	(5.26E-05 )
120	(7.05E-05 )	(8.24E-05 )	(8.11E-05 )	(5.24E-05 )
150	(7.03E-05 )	(8.22E-05 )	(8.09E-05 )	(5.23E-05 )
180	(7.02E-05 )	(8.20E-05 )	(8.07E-05 )	(5.22E-05 )
210	(7.00E-05 )	(8.18E-05 )	(8.05E-05 )	(5.20E-05 )
240	(6.98E-05 )	(8.16E-05 )	(8.03E-05 )	(5.19E-05 )
270	(6.96E-05 )	8.14E-05	(8.01E-05 )	5.18E-05
300	6.94E-05	8.84E-05	7.99E-05	4.77E-05
330	6.25E-05	8.96E-05	8.26E-05	4.90E-05
360	6.14E-05	8.21E-05	7.86E-05	5.00E-05
390	5.29E-05	7.85E-05	8.39E-05	5.68E-05
420	5.02E-05	9.17E-05	8.80E-05	5.83E-05
450	5.16E-05	9.39E-05	8.49E-05	6.04E-05
480	5.21E-05	9.31E-05	7.59E-05	5.73E-05
510	5.07E-05	9.07E-05	7.39E-05	6.51E-05
540	4.87E-05	8.37E-05	8.28E-05	6.78E-05
570	4.74E-05	8.53E-05	8.02E-05	7.05E-05
600	6.02E-05	9.52E-05	8.59E-05	7.13E-05
630	6.04E-05	9.53E-05	1.05E-04	7.24E-05
660	7.56E-05	9.45E-05	9.40E-05	6.85E-05
690	1.48E-04	9.28E-05	1.05E-04	6.92E-05
720	1.53E-04	9.33E-05	1.10E-04	6.38E-05
750	1.54E-04	9.91E-05	1.15E-04	6.24E-05
780	1.47E-04	1.01E-04	1.21E-04	6.52E-05
810	1.44E-04	1.04E-04	1.20E-04	6.25E-05
840	1.41E-04	1.25E-04	1.19E-04	6.19E-05
870	1.34E-04	1.29E-04	1.26E-04	6.66E-05
900	1.25E-04	1.28E-04	1.22E-04	7.35E-05
930	1.24E-04	1.26E-04	1.21E-04	6.91E-05
960	1.25E-04	1.28E-04	1.27E-04	6.29E-05
990	1.34E-04	1.34E-04	1.27E-04	6.13E-05
1020	1.39E-04	1.30E-04	1.10E-04	5.73E-05
1050	1.44E-04	1.64E-04	1.12E-04	6.19E-05
1080	1.19E-04	1.69E-04	1.10E-04	6.29E-05
1110	1.16E-04	1.44E-04	1.08E-04	6.32E-05
1140	1.08E-04	1.34E-04	9.97E-05	6.06E-05
1170	1.32E-04	1.19E-04	8.98E-05	5.38E-05
1200	1.41E-04	1.01E-04	8.00E-05	5.09E-05
1230	1.38E-04	1.05E-04	7.85E-05	4.94E-05
1260	1.32E-04	9.76E-05	7.71E-05	4.83E-05
1290	1.24E-04	8.49E-05	7.87E-05	4.48E-05
1320	1.22E-04	8.12E-05	8.04E-05	4.13E-05
1350	1.28E-04	6.45E-05	7.96E-05	3.14E-05
1380	1.35E-04	6.50E-05	8.67E-05	2.72E-05
1410	1.34E-04	6.51E-05	8.04E-05	2.41E-05
1440	1.27E-04	6.13E-05	6.97E-05	2.12E-05
1470	1.15E-04	5.14E-05	5.91E-05	1.87E-05
1500	8.41E-05	3.58E-05	5.15E-05	1.92E-05

**FLIGHT NO. C-379**  
**TOTAL VOLUME SCATTERING COEFFICIENT**

(JOB 2678 DATE 03/09/77)  
 DATE 51776 FLIGHT NO. C-379 GROUND LEVEL ALTITUDE (M)= 0

ALTITUDE (M)	FILTERS	TOTAL VOLUME SCATTERING COEFFICIENT (PER M)			
		2	4	3	5
1530	8.12E-05	2.81E-05	4.70E-05	1.82E-05	
1560	7.67E-05	2.93E-05	3.53E-05	1.85E-05	
1590	7.03E-05	2.91E-05	2.55E-05	1.59E-05	
1620	5.19E-05	3.17E-05	1.91E-05	1.56E-05	
1650	4.53E-05	3.29E-05	1.77E-05	1.58E-05	
1680	4.66E-05	2.99E-05	1.62E-05	1.64E-05	
1710	4.84E-05	2.67E-05	1.92E-05	1.68E-05	
1740	4.85E-05	2.43E-05	1.94E-05	1.88E-05	
1770	4.42E-05	2.42E-05	1.94E-05	1.91E-05	
1800	4.00E-05	2.93E-05	2.30E-05	2.03E-05	
1830	4.02E-05	3.79E-05	2.66E-05	2.14E-05	
1860	4.28E-05	4.14E-05	2.75E-05	2.18E-05	
1890	4.40E-05	4.09E-05	2.73E-05	2.12E-05	
1920	4.54E-05	4.03E-05	2.67E-05	1.96E-05	
1950	4.49E-05	3.83E-05	2.63E-05	1.93E-05	
1980	5.05E-05	3.60E-05	2.61E-05	1.92E-05	
2010	5.61E-05	3.38E-05	2.58E-05	1.80E-05	
2040	5.88E-05	2.43E-05	2.56E-05	1.58E-05	
2070	5.63E-05	2.88E-05	2.21E-05	1.55E-05	
2100	5.67E-05	2.89E-05	1.99E-05	1.56E-05	
2130	5.62E-05	2.92E-05	2.01E-05	1.58E-05	
2160	4.72E-05	2.90E-05	2.01E-05	1.65E-05	
2190	4.4CE-05	2.88E-05	1.77E-05	1.89E-05	
2220	4.39E-05	2.88E-05	1.90E-05	2.26E-05	
2250	4.42E-05	3.60E-05	2.25E-05	2.32E-05	
2280	4.43E-05	4.32E-05	2.93E-05	2.47E-05	
2310	4.45E-05	7.21E-05	4.26E-05	2.63E-05	
2340	4.39E-05	7.41E-05	5.01E-05	2.69E-05	
2370	4.46E-05	7.20E-05	4.92E-05	2.92E-05	
2400	5.05E-05	7.14E-05	5.07E-05	3.09E-05	
2430	5.21E-05	7.19E-05	5.23E-05	3.21E-05	
2460	5.37E-05	7.12E-05	5.33E-05	3.41E-05	
2490	7.17E-05	6.98E-05	5.34E-05	3.70E-05	
2520	8.35E-05	6.72E-05	5.17E-05	3.54E-05	
2550	7.69E-05	7.13E-05	5.11E-05	3.45E-05	
2580	7.02E-05	7.41E-05	5.01E-05	3.32E-05	
2610	7.93E-05	6.72E-05	4.08E-05	3.06E-05	
2640	8.16E-05	4.82E-05	3.38E-05	2.17E-05	
2670	8.20E-05	3.81E-05	3.00E-05	1.55E-05	
2700	6.83E-05	3.40E-05	3.07E-05	1.39E-05	
2730	5.79E-05	3.52E-05	3.17E-05	1.35E-05	
2760	5.52E-05	2.97E-05	3.08E-05	1.42E-05	
2790	5.24E-05	2.90E-05	2.12E-05	1.37E-05	
2820	4.26E-05	2.57E-05	1.83E-05	1.39E-05	
2850	4.26E-05	2.45E-05	1.81E-05	1.39E-05	
2880	4.26E-05	2.33E-05	1.77E-05	1.39E-05	
2910	4.26E-05	2.55E-05	1.86E-05	1.41E-05	
2940	4.31E-05	2.84E-05	1.78E-05	1.45E-05	
2970	4.37E-05	2.82E-05	1.78E-05	1.41E-05	
3000	4.33E-05	2.66E-05	1.83E-05	1.38E-05	

**FLIGHT NO. C-379**  
**TOTAL VOLUME SCATTERING COEFFICIENT**

(JOB 2678 DATE 03/09/77)  
 DATE 51776 FLIGHT NO. C-379 GROUND LEVEL ALTITUDE (M)= 0

ALTITUDE (M)	FILTERS	TOTAL VOLUME SCATTERING COEFFICIENT (PER M)			
		2	4	3	5
3030	4.30E-05	2.49E-05	1.81E-05	1.36E-05	
3060	4.19E-05	2.46E-05	1.76E-05	1.42E-05	
3090	4.27E-05	2.48E-05	1.78E-05	1.41E-05	
3120	4.35E-05	2.42E-05	1.82E-05	1.40E-05	
3150	4.25E-05	2.42E-05	1.81E-05	1.36E-05	
3180	4.41E-05	2.50E-05	1.79E-05	1.33E-05	
3210	4.33E-05	2.59E-05	1.72E-05	1.38E-05	
3240	4.15E-05	2.63E-05	1.66E-05	1.29E-05	
3270	3.97E-05	2.65E-05	1.57E-05	1.33E-05	
3300	5.76E-05	2.67E-05	1.54E-05	1.29E-05	
3330	6.13E-05	2.64E-05	1.54E-05	1.25E-05	
3360	5.74E-05	2.50E-05	1.57E-05	1.22E-05	
3390	5.54E-05	2.64E-05	1.59E-05	1.27E-05	
3420	4.70E-05	2.65E-05	1.63E-05	1.25E-05	
3450	4.60E-05	2.64E-05	1.68E-05	1.25E-05	
3480	4.23E-05	2.58E-05	1.68E-05	1.29E-05	
3510	4.09E-05	2.51E-05	1.72E-05	1.22E-05	
3540	3.95E-05	2.44E-05	1.83E-05	1.27E-05	
3570	3.56E-05	2.46E-05	1.78E-05	1.26E-05	
3600	3.17E-05	2.32E-05	1.72E-05	1.26E-05	
3630	4.47E-05	2.30E-05	1.39E-05	1.25E-05	
3660	4.74E-05	2.23E-05	1.41E-05	1.22E-05	
3690	4.64E-05	2.48E-05	1.51E-05	1.18E-05	
3720	4.28E-05	2.54E-05	1.55E-05	1.22E-05	
3750	4.25E-05	2.46E-05	1.49E-05	1.29E-05	
3780	4.22E-05	2.47E-05	1.51E-05	1.25E-05	
3810	4.19E-05	2.47E-05	1.47E-05	1.33E-05	
3840	3.96E-05	2.42E-05	1.60E-05	1.33E-05	
3870	3.84E-05	2.32E-05	1.61E-05	1.32E-05	
3900	3.67E-05	2.17E-05	1.68E-05	1.30E-05	
3930	3.14E-05	2.11E-05	1.63E-05	1.10E-05	
3960	4.46E-05	2.08E-05	1.48E-05	1.08E-05	
3990	4.34E-05	2.38E-05	1.37E-05	1.14E-05	
4020	4.26E-05	2.40E-05	1.40E-05	1.26E-05	
4050	4.11E-05	2.40E-05	1.43E-05	1.32E-05	
4080	4.14E-05	2.41E-05	1.44E-05	1.32E-05	
4110	4.16E-05	2.38E-05	1.45E-05	1.33E-05	
4140	4.06E-05	2.36E-05	1.46E-05	1.37E-05	
4170	4.02E-05	2.32E-05	1.47E-05	1.40E-05	
4200	4.00E-05	2.45E-05	1.49E-05	1.40E-05	
4230	3.73E-05	2.46E-05	1.41E-05	1.46E-05	
4260	3.45E-05	2.52E-05	1.39E-05	1.40E-05	
4290	3.04E-05	2.58E-05	1.47E-05	1.63E-05	
4320	2.95E-05	2.87E-05	1.49E-05	1.71E-05	
4350	3.67E-05	3.17E-05	1.51E-05	1.68E-05	
4380	4.38E-05	2.78E-05	1.54E-05	1.73E-05	
4410	4.25E-05	2.69E-05	1.67E-05	1.82E-05	
4440	4.18E-05	2.61E-05	1.61E-05	1.68E-05	
4470	4.00E-05	2.55E-05	1.58E-05	1.58E-05	
4500	3.89E-05	2.66E-05	1.52E-05	1.43E-05	

# FLIGHT NO. C-379

## TOTAL VOLUME SCATTERING COEFFICIENT

(JOB 2678 DATE 03/C9/77)  
 DATE 51776 FLIGHT NO. C-379 GROUND LEVEL ALTITUDE (M)= 0

ALTITUDE (M)	FILTERS	TOTAL VOLUME SCATTERING COEFFICIENT (PER M)			
		2	4	3	5
4530	3.84E-05	2.69E-05	1.47E-05	1.38E-05	
4560	3.72E-05	2.54E-05	1.33E-05	1.31E-05	
4590	3.89E-05	2.57E-05	1.38E-05	1.29E-05	
4620	4.05E-05	2.40E-05	1.40E-05	1.34E-05	
4650	4.90E-05	2.33E-05	1.35E-05	1.34E-05	
4680	4.84E-05	2.48E-05	1.42E-05	1.35E-05	
4710	4.79E-05	2.64E-05	1.41E-05	1.33E-05	
4740	3.88E-05	2.54E-05	1.42E-05	1.30E-05	
4770	3.95E-05	2.45E-05	1.38E-05	1.31E-05	
4800	4.97E-05	2.39E-05	1.34E-05	1.33E-05	
4830	4.68E-05	2.29E-05	1.32E-05	1.32E-05	
4860	4.51E-05	2.17E-05	1.35E-05	1.25E-05	
4890	4.33E-05	2.13E-05	1.35E-05	1.18E-05	
4920	4.15E-05	2.71E-05	1.35E-05	1.24E-05	
4950	4.04E-05	2.34E-05	1.36E-05	1.36E-05	
4980	3.89E-05	2.37E-05	1.30E-05	1.29E-05	
5010	3.93E-05	2.49E-05	1.50E-05	1.28E-05	
5040	3.54E-05	2.70E-05	1.62E-05	1.33E-05	
5070	3.15E-05	2.90E-05	1.64E-05	1.27E-05	
5100	3.12E-05	3.11E-05	1.66E-05	1.27E-05	
5130	3.09E-05	2.74E-05	1.77E-05	1.29E-05	
5160	4.40E-05	2.61E-05	1.74E-05	1.33E-05	
5190	4.32E-05	2.57E-05	2.78E-05	1.37E-05	
5220	4.34E-05	2.40E-05	2.51E-05	1.36E-05	
5250	4.11E-05	2.52E-05	1.36E-05	1.42E-05	
5280	4.07E-05	2.65E-05	1.29E-05	1.47E-05	
5310	3.98E-05	2.57E-05	1.38E-05	1.50E-05	
5340	4.15E-05	2.49E-05	1.31E-05	1.49E-05	
5370	4.11E-05	2.51E-05	1.37E-05	1.48E-05	
5400	3.95E-05	2.51E-05	1.39E-05	1.46E-05	
5430	5.07E-05	2.50E-05	1.43E-05	1.44E-05	
5460	5.02E-05	2.41E-05	1.42E-05	1.51E-05	
5490	4.78E-05	2.33E-05	1.41E-05	1.47E-05	
5520	4.70E-05	2.20E-05	1.39E-05	1.44E-05	
5550	4.46E-05	2.21E-05	1.50E-05	1.45E-05	
5580	4.37E-05	2.24E-05	1.59E-05	1.46E-05	
5610	4.16E-05	2.13E-05	1.49E-05	1.39E-05	
5640	4.08E-05	2.03E-05	1.49E-05	1.41E-05	
5670	3.80E-05	2.31E-05	1.44E-05	1.43E-05	
5700	3.49E-05	2.27E-05	1.12E-05	1.25E-05	
5730	3.21E-05	2.26E-05	1.26E-05	1.29E-05	
5760	4.22E-05	2.21E-05	1.29E-05	1.30E-05	
5790	4.27E-05	2.16E-05	1.28E-05	1.32E-05	
5820	4.02E-05	2.21E-05	1.26E-05	1.31E-05	
5850	3.89E-05	2.26E-05	1.24E-05	1.30E-05	
5880	3.77E-05	2.23E-05	1.29E-05	1.30E-05	
5910	3.64E-05	2.19E-05	1.29E-05	1.28E-05	
5940	3.65E-05	2.30E-05	1.25E-05	1.28E-05	
5970	3.67E-05	2.26E-05	1.32E-05	1.28E-05	
6000	3.63E-05	2.18E-05	1.52E-05	1.30E-05	
6030	3.59E-05	2.11E-05	1.52E-05	1.32E-05	
6060	3.57E-05	2.07E-05	1.47E-05	1.41E-05	
6090	3.43E-05	2.19E-05	1.46E-05	1.41E-05	
6120	3.21E-05	2.32E-05	1.50E-05	1.35E-05	
6150	3.31E-05	2.28E-05	1.48E-05	1.38E-05	
6180	3.57E-05	2.29E-05	1.45E-05	1.33E-05	
6210	3.83E-05	2.20E-05	1.41E-05	1.27E-05	
6240	3.64E-05	2.44E-05	1.44E-05	1.26E-05	
6270	3.46E-05	( 2.43E-05 )	1.45E-05	( 1.25E-05 )	
6300	( 3.45E-05 )	( 2.42E-05 )	( 1.45E-05 )	( 1.25E-05 )	
FIRST DATA ALT	300	270	300	270	
LAST DATA ALT	6270	6240	6270	6240	

**FLIGHT NO. C-379**  
**VERTICAL BEAM TRANSMITTANCE FROM GROUND TO ALTITUDE**

ALTITUDE (M)	VERTICAL BEAM TRANSMITTANCE FROM GROUND TO ALTITUDE			
	FILTERS 2	4	3	5
0	1.00E 00	1.00E 00	1.00E 00	1.00E 00
300	9.79E-01	9.76E-01	9.76E-01	9.84E-01
600	9.63E-01	9.50E-01	9.52E-01	9.67E-01
900	9.28E-01	9.21E-01	9.21E-01	9.48E-01
1200	8.93E-01	8.84E-01	8.91E-01	9.31E-01
1500	8.60E-01	8.64E-01	8.71E-01	9.21E-01
1800	8.45E-01	8.57E-01	8.64E-01	9.16E-01
2100	8.33E-01	8.48E-01	8.58E-01	9.11E-01
2400	8.21E-01	8.36E-01	8.50E-01	9.05E-01
2700	8.04E-01	8.21E-01	8.38E-01	8.97E-01
3000	7.92E-01	8.14E-01	8.33E-01	8.93E-01
3300	7.82E-01	8.07E-01	8.29E-01	8.90E-01
3600	7.71E-01	8.01E-01	8.24E-01	8.86E-01
3900	7.62E-01	7.96E-01	8.21E-01	8.83E-01
4200	7.52E-01	7.90E-01	8.17E-01	8.80E-01
4500	7.44E-01	7.84E-01	8.13E-01	8.75E-01
4800	7.35E-01	7.78E-01	8.10E-01	8.72E-01
5100	7.26E-01	7.72E-01	8.06E-01	8.68E-01
5400	7.17E-01	7.66E-01	8.02E-01	8.65E-01
5700	7.08E-01	7.61E-01	7.99E-01	8.61E-01
6000	7.00E-01	7.56E-01	7.96E-01	8.58E-01
6300	6.92E-01	7.51E-01	7.92E-01	8.54E-01

**FLIGHT NO. C-379**  
**EQUIVALENT ATTENUATION LENGTH**

(JOB 2678 DATE 03/09/77)  
 DATE 51776 FLIGHT NO. C-379 GROUND LEVEL ALTITUDE (M)= 0

ALTITUDE (M)	EQUIVALENT ATTENUATION LENGTH (M)			
	FILTERS 2	4	3	5
0	1.40E 04	1.20E 04	1.22E 04	1.88E 04
300	1.42E 04	1.21E 04	1.24E 04	1.92E 04
600	1.61E 04	1.17E 04	1.23E 04	1.79E 04
900	1.20E 04	1.09E 04	1.09E 04	1.68E 04
1200	1.06E 04	9.72E 03	1.04E 04	1.67E 04
1500	9.92E 03	1.03E 04	1.09E 04	1.83E 04
1800	1.07E 04	1.17E 04	1.23E 04	2.06E 04
2100	1.15E 04	1.27E 04	1.37E 04	2.26E 04
2400	1.22E 04	1.34E 04	1.48E 04	2.40E 04
2700	1.24E 04	1.36E 04	1.53E 04	2.48E 04
3000	1.29E 04	1.45E 04	1.64E 04	2.66E 04
3300	1.34E 04	1.54E 04	1.75E 04	2.82E 04
3600	1.39E 04	1.63E 04	1.87E 04	2.98E 04
3900	1.43E 04	1.71E 04	1.97E 04	3.13E 04
4200	1.48E 04	1.78E 04	2.08E 04	3.27E 04
4500	1.52E 04	1.85E 04	2.18E 04	3.38E 04
4800	1.56E 04	1.91E 04	2.28E 04	3.50E 04
5100	1.59E 04	1.97E 04	2.37E 04	3.62E 04
5400	1.62E 04	2.03E 04	2.45E 04	3.72E 04
5700	1.65E 04	2.09E 04	2.54E 04	3.81E 04
6000	1.68E 04	2.14E 04	2.63E 04	3.91E 04
6300	1.71E 04	2.20E 04	2.71E 04	4.00E 04

FLIGHT C-381 – 25 MAY 1976 – DESCRIPTION OF FLIGHT AND WEATHER CHARACTERISTICS

Filter Identification	Data Interval			Solar Zenith Angle			Maximum Flight Altitude (meters)	Average Terrain Elevation (meters)
	Start (GMT)	End (GMT)	Elapsed (hrs)	Initial ST & LV (degrees)	Solar Transit (degrees)	Final VPRO (degrees)		
2 and 4	1058	1241	1.7	32.4	32.0	35.1	5490	18
3 and 5	1246	1416	1.5	35.5	—	45.6	5460	18

Flight C-381 was a midday flight spanning local apparent noon. It was partly cloudy throughout the flight with scattered low altitude cumulus and scattered cirrus above the highest flight altitude. The in-flight pictures indicate relatively clear upper hemispheres at the maximum flight altitudes along most of the track.

The approximate northeast to southwest track was located between Oldenberg and Lathen in northwestern Germany. Typical terrain features were heavily cultivated low lying flat farmlands interspersed with occasional dark woods and small towns.

The in-flight observer reported 3/8 cumulus at 900 meters (3000 feet) with tops at 2100 meters (7000 feet) early in the flight. Scattered cirrus varied from 1/8 to 3/8 coverage at 7500 meters (25000 feet).

At Oldenberg, 40 kilometers eastnortheast of the track center point, 6/8 cumulus at 300 meters (1000 feet) were reported at 0944 GMT. The cloud layer decreased to scattered 3/8 to 4/8 and the bases lifted to 900 meters (3000 feet) by 1200 GMT. Visibility was reported as 5 to 11.2 kilometers.

Ahlhorn, 43 kilometers eastsoutheast of the track center point, reported similar conditions.

Meppen, 42 kilometers southwest of the track center point, reported 1/8 cumulus at 900 meters (3000 feet) at 1000 GMT increasing to 4/8 at 1020 meters (3400 feet) by 1200 GMT. Visibility was 7 to 9 kilometers.

The radiosonde station at Rheine/Waldhugel was 81 kilometers south of the flight track center point and located in a prevailing airflow that was parallel with the track.

The surface charts show a weak pressure gradient over Germany. A weakening cold front extended along a line from Edinburgh to Calais to Valencia. At 500 millibars there was a closed low over northwestern Germany at 0000 GMT. By 1200 GMT this low had filled and there was a trough from the British Isles to northwestern Germany. Winds were moderate westerly. The airmass was stable maritime polar.

# FLIGHT NO. C-381

MEPPEN

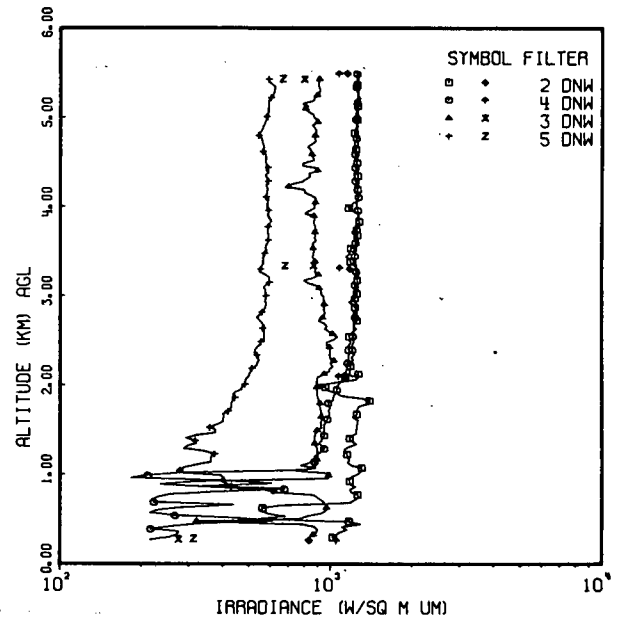
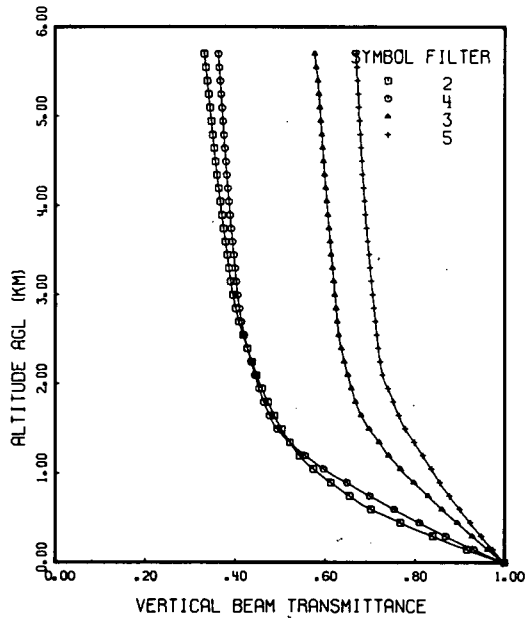
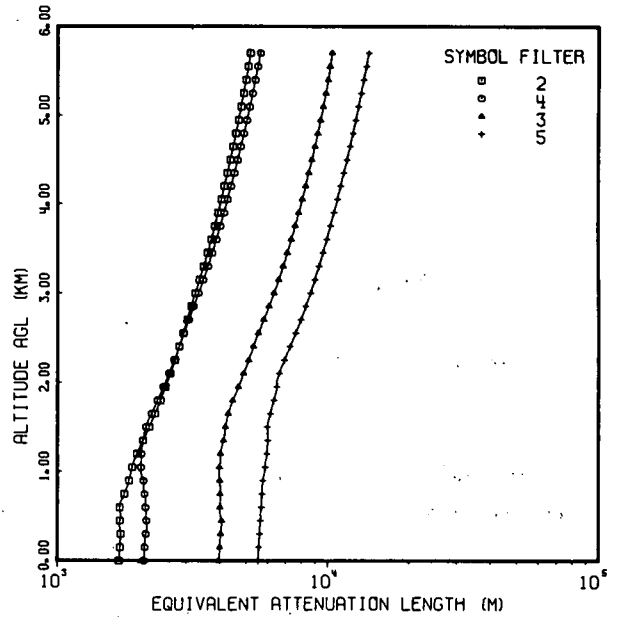
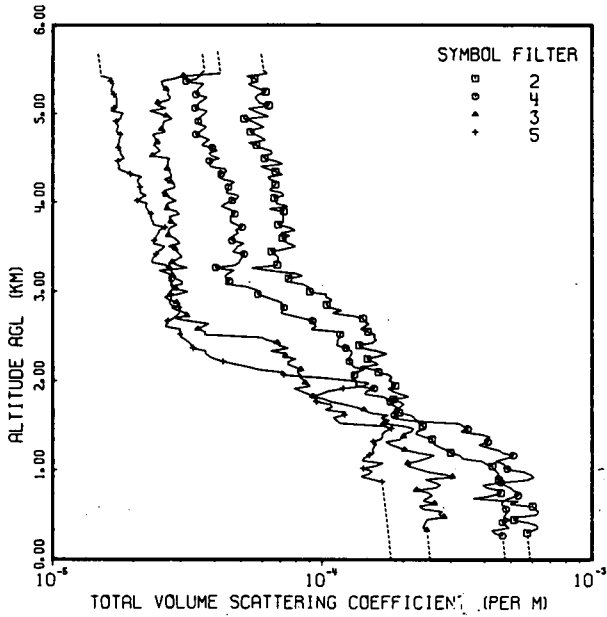

**FLIGHT NO. C-381**  
**TOTAL VOLUME SCATTERING COEFFICIENT**

(JOB 2677 DATE 03/09/77)  
 DATE 52576 FLIGHT NO. C-381 GROUND LEVEL ALTITUDE (M)= 18

ALTITUDE (M)	TOTAL VOLUME SCATTERING COEFFICIENT (PER M)			
	FILTERS	2	4	3
0	(5.91E-04 )	(4.78E-04 )	(2.52E-04 )	(1.81E-04 )
30	(5.88E-04 )	(4.76E-04 )	(2.51E-04 )	(1.80E-04 )
60	(5.87E-04 )	(4.75E-04 )	(2.50E-04 )	(1.80E-04 )
90	(5.85E-04 )	(4.74E-04 )	(2.50E-04 )	(1.79E-04 )
120	(5.84E-04 )	(4.72E-04 )	(2.49E-04 )	(1.79E-04 )
150	(5.82E-04 )	(4.71E-04 )	(2.49E-04 )	(1.78E-04 )
180	(5.81E-04 )	(4.70E-04 )	(2.48E-04 )	(1.78E-04 )
210	(5.79E-04 )	(4.69E-04 )	(2.47E-04 )	(1.77E-04 )
240	(5.78E-04 )	(4.68E-04 )	(2.47E-04 )	(1.77E-04 )
270	(5.76E-04 )	4.66E-04	(2.46E-04 )	(1.76E-04 )
300	5.75E-04	4.34E-04	(2.45E-04 )	(1.76E-04 )
330	6.02E-04	4.27E-04	2.45E-04	(1.75E-04 )
360	6.29E-04	4.92E-04	2.36E-04	(1.75E-04 )
390	6.24E-04	4.75E-04	2.40E-04	(1.75E-04 )
420	5.81E-04	4.65E-04	2.43E-04	(1.74E-04 )
450	5.13E-04	4.96E-04	2.45E-04	(1.74E-04 )
480	5.22E-04	4.69E-04	2.83E-04	(1.73E-04 )
510	6.25E-04	4.79E-04	2.70E-04	(1.73E-04 )
540	6.34E-04	4.85E-04	2.80E-04	(1.72E-04 )
570	6.19E-04	4.80E-04	2.36E-04	(1.72E-04 )
600	6.02E-04	4.74E-04	2.29E-04	(1.71E-04 )
630	4.98E-04	4.62E-04	2.61E-04	(1.71E-04 )
660	5.31E-04	4.70E-04	2.37E-04	(1.70E-04 )
690	3.62E-04	4.89E-04	2.46E-04	(1.70E-04 )
720	4.22E-04	5.32E-04	2.56E-04	(1.69E-04 )
750	4.60E-04	5.46E-04	2.48E-04	(1.69E-04 )
780	4.53E-04	5.09E-04	2.23E-04	(1.68E-04 )
810	4.07E-04	5.00E-04	2.67E-04	(1.68E-04 )
840	3.92E-04	4.74E-04	2.76E-04	(1.67E-04 )
870	4.63E-04	4.60E-04	2.58E-04	1.67E-04
900	4.50E-04	5.81E-04	2.41E-04	1.53E-04
930	4.40E-04	6.11E-04	3.04E-04	1.40E-04
960	4.52E-04	5.88E-04	2.82E-04	1.49E-04
990	4.45E-04	5.57E-04	2.43E-04	1.54E-04
1020	4.30E-04	4.84E-04	2.25E-04	1.42E-04
1050	4.26E-04	4.77E-04	2.08E-04	1.59E-04
1080	4.04E-04	4.70E-04	2.07E-04	1.68E-04
1110	3.89E-04	4.40E-04	2.30E-04	1.41E-04
1140	3.29E-04	4.81E-04	2.45E-04	1.44E-04
1170	3.25E-04	5.11E-04	2.61E-04	1.50E-04
1200	2.99E-04	4.67E-04	2.25E-04	1.56E-04
1230	2.89E-04	4.52E-04	2.02E-04	1.54E-04
1260	2.75E-04	4.11E-04	1.90E-04	1.56E-04
1290	2.62E-04	3.81E-04	1.78E-04	1.59E-04
1320	2.57E-04	4.11E-04	1.72E-04	1.54E-04
1350	2.55E-04	4.02E-04	1.95E-04	1.66E-04
1380	2.38E-04	4.21E-04	2.00E-04	1.68E-04
1410	2.23E-04	3.86E-04	2.02E-04	1.67E-04
1440	2.24E-04	3.28E-04	2.14E-04	1.72E-04
1470	2.41E-04	3.47E-04	2.19E-04	1.80E-04
1500	2.35E-04	3.33E-04	2.00E-04	1.69E-04

**FLIGHT NO. C-381**  
**TOTAL VOLUME SCATTERING COEFFICIENT**

(JOB 2677 DATE 03/C9/77)  
 DATE 52576 FLIGHT NO. C-381 GROUND LEVEL ALTITUDE (M)= 18

ALTITUDE (M)	TOTAL VOLUME SCATTERING COEFFICIENT (PER M)				
	FILTERS	2	4	3	5
1530		2.30E-04	3.20E-04	1.69E-04	1.16E-04
1560		2.25E-04	2.15E-04	1.78E-04	1.13E-04
1590		2.19E-04	1.84E-04	1.65E-04	1.10E-04
1620		2.14E-04	1.85E-04	1.76E-04	1.21E-04
1650		1.93E-04	1.86E-04	1.49E-04	1.22E-04
1680		1.88E-04	1.85E-04	1.43E-04	1.03E-04
1710		1.94E-04	1.89E-04	1.33E-04	1.09E-04
1740		2.01E-04	1.81E-04	1.21E-04	1.07E-04
1770		1.95E-04	1.78E-04	1.08E-04	9.54E-05
1800		1.84E-04	1.76E-04	1.02E-04	9.42E-05
1830		2.09E-04	1.67E-04	9.27E-05	9.41E-05
1860		1.95E-04	1.44E-04	8.83E-05	9.92E-05
1890		1.83E-04	1.46E-04	8.38E-05	1.06E-04
1920		1.76E-04	1.56E-04	7.88E-05	1.20E-04
1950		1.87E-04	1.34E-04	9.04E-05	1.43E-04
1980		1.84E-04	1.34E-04	8.67E-05	1.49E-04
2010		1.77E-04	1.34E-04	8.64E-05	1.28E-04
2040		1.82E-04	1.28E-04	8.29E-05	9.98E-05
2070		1.79E-04	1.32E-04	8.37E-05	7.22E-05
2100		1.62E-04	1.33E-04	8.08E-05	7.15E-05
2130		1.56E-04	1.43E-04	8.35E-05	5.80E-05
2160		1.39E-04	1.31E-04	7.88E-05	5.28E-05
2190		1.61E-04	1.28E-04	7.44E-05	4.76E-05
2220		1.54E-04	1.26E-04	7.51E-05	4.29E-05
2250		1.47E-04	1.26E-04	7.99E-05	3.99E-05
2280		1.60E-04	1.27E-04	7.31E-05	3.82E-05
2310		1.74E-04	1.29E-04	7.42E-05	3.69E-05
2340		1.59E-04	1.29E-04	6.45E-05	3.70E-05
2370		1.42E-04	1.22E-04	7.46E-05	3.32E-05
2400		1.37E-04	1.13E-04	6.89E-05	3.28E-05
2430		1.55E-04	1.14E-04	6.82E-05	3.22E-05
2460		1.59E-04	1.14E-04	6.21E-05	3.12E-05
2490		1.55E-04	1.16E-04	5.93E-05	3.01E-05
2520		1.57E-04	1.17E-04	3.65E-05	2.98E-05
2550		1.48E-04	1.20E-04	3.69E-05	2.96E-05
2580		1.39E-04	9.10E-05	3.46E-05	2.99E-05
2610		1.44E-04	9.50E-05	3.63E-05	2.63E-05
2640		1.49E-04	9.36E-05	3.79E-05	2.64E-05
2670		1.43E-04	9.23E-05	3.26E-05	2.68E-05
2700		1.42E-04	8.53E-05	2.86E-05	2.81E-05
2730		1.29E-04	7.78E-05	3.16E-05	2.88E-05
2760		1.09E-04	7.04E-05	3.11E-05	2.95E-05
2790		1.18E-04	7.13E-05	2.91E-05	2.97E-05
2820		1.08E-04	7.23E-05	2.76E-05	2.95E-05
2850		1.04E-04	7.08E-05	2.95E-05	2.75E-05
2880		1.04E-04	7.07E-05	2.88E-05	2.71E-05
2910		1.09E-04	6.62E-05	2.69E-05	2.76E-05
2940		1.04E-04	6.19E-05	2.60E-05	2.76E-05
2970		1.04E-04	5.76E-05	2.89E-05	2.74E-05
3000		8.99E-05	5.93E-05	3.18E-05	2.71E-05

**FLIGHT NO. C-381**  
**TOTAL VOLUME SCATTERING COEFFICIENT**

(JOB 2677 DATE 03/09/77)  
 DATE 52576 FLIGHT NO. C-381 GROUND LEVEL ALTITUDE (M)= 18

ALTITUDE (M)	FILTERS	TOTAL VOLUME SCATTERING COEFFICIENT (PER M)			
		2	4	3	5
3030	9.04E-05	5.57E-05	2.87E-05	2.83E-05	
3060	8.86E-05	5.25E-05	2.74E-05	2.79E-05	
3090	8.43E-05	4.37E-05	3.04E-05	2.73E-05	
3120	7.36E-05	4.53E-05	3.02E-05	2.76E-05	
3150	7.50E-05	4.43E-05	2.83E-05	2.70E-05	
3180	8.45E-05	4.36E-05	2.79E-05	2.73E-05	
3210	7.90E-05	4.53E-05	2.67E-05	2.79E-05	
3240	6.41E-05	4.72E-05	2.48E-05	2.76E-05	
3270	5.48E-05	4.03E-05	3.15E-05	2.71E-05	
3300	6.81E-05	4.78E-05	2.88E-05	2.62E-05	
3330	6.83E-05	4.93E-05	2.77E-05	2.33E-05	
3360	6.85E-05	4.99E-05	2.90E-05	2.34E-05	
3390	6.88E-05	5.05E-05	3.01E-05	2.38E-05	
3420	6.68E-05	5.14E-05	2.97E-05	2.42E-05	
3450	6.48E-05	4.65E-05	2.89E-05	2.45E-05	
3480	7.29E-05	4.81E-05	2.85E-05	2.56E-05	
3510	7.98E-05	4.88E-05	2.69E-05	2.60E-05	
3540	7.52E-05	5.14E-05	2.97E-05	2.36E-05	
3570	7.20E-05	4.63E-05	2.90E-05	2.38E-05	
3600	7.12E-05	4.60E-05	2.84E-05	2.41E-05	
3630	7.59E-05	4.73E-05	2.69E-05	2.44E-05	
3660	7.04E-05	4.90E-05	2.72E-05	2.48E-05	
3690	7.95E-05	4.77E-05	2.70E-05	2.49E-05	
3720	7.55E-05	5.05E-05	2.74E-05	2.61E-05	
3750	6.87E-05	4.83E-05	2.90E-05	2.36E-05	
3780	7.19E-05	4.58E-05	2.75E-05	2.35E-05	
3810	7.15E-05	4.57E-05	2.72E-05	2.32E-05	
3840	7.15E-05	4.56E-05	2.70E-05	2.30E-05	
3870	7.16E-05	4.75E-05	2.95E-05	2.32E-05	
3900	7.20E-05	4.73E-05	2.88E-05	2.26E-05	
3930	6.38E-05	4.47E-05	2.66E-05	2.23E-05	
3960	7.45E-05	4.22E-05	2.63E-05	2.21E-05	
3990	6.76E-05	4.41E-05	2.68E-05	2.25E-05	
4020	6.70E-05	4.64E-05	2.87E-05	2.06E-05	
4050	6.64E-05	4.88E-05	2.73E-05	2.13E-05	
4080	7.22E-05	4.89E-05	2.63E-05	2.23E-05	
4110	7.09E-05	4.39E-05	2.54E-05	2.11E-05	
4140	6.38E-05	4.49E-05	2.64E-05	2.12E-05	
4170	6.55E-05	4.50E-05	2.84E-05	2.11E-05	
4200	6.71E-05	4.50E-05	2.83E-05	2.10E-05	
4230	6.81E-05	4.74E-05	2.74E-05	2.07E-05	
4260	6.41E-05	4.29E-05	2.59E-05	2.08E-05	
4290	6.28E-05	4.11E-05	2.76E-05	2.15E-05	
4320	7.10E-05	4.22E-05	2.74E-05	1.94E-05	
4350	6.71E-05	4.41E-05	2.71E-05	1.85E-05	
4380	6.30E-05	4.36E-05	2.65E-05	1.75E-05	
4410	5.92E-05	3.83E-05	2.68E-05	1.77E-05	
4440	7.12E-05	3.80E-05	2.67E-05	1.74E-05	
4470	6.72E-05	3.81E-05	2.67E-05	1.74E-05	
4500	6.10E-05	4.16E-05	2.71E-05	1.84E-05	

**FLIGHT NO. C-381**  
**TOTAL VOLUME SCATTERING COEFFICIENT**

(JOB 2677 DATE 03/09/77)  
 DATE 52576 FLIGHT NO. C-381 GROUND LEVEL ALTITUDE (M)= 18

ALTITUDE (M)	TOTAL VOLUME SCATTERING COEFFICIENT (PER M)				
	FILTERS	2	4	3	5
4530		6.05E-05	3.88E-05	2.34E-05	1.81E-05
4560		6.51E-05	3.80E-05	2.42E-05	1.78E-05
4590		6.45E-05	4.07E-05	2.51E-05	1.78E-05
4620		5.95E-05	3.92E-05	2.44E-05	1.75E-05
4650		5.68E-05	3.57E-05	2.37E-05	1.73E-05
4680		5.33E-05	3.70E-05	2.44E-05	1.77E-05
4710		6.13E-05	3.82E-05	2.41E-05	1.78E-05
4740		5.90E-05	3.60E-05	2.38E-05	1.78E-05
4770		5.66E-05	3.39E-05	2.35E-05	1.78E-05
4800		5.40E-05	3.51E-05	2.61E-05	1.72E-05
4830		5.58E-05	3.61E-05	2.53E-05	1.74E-05
4860		6.08E-05	3.71E-05	2.55E-05	1.76E-05
4890		5.75E-05	3.46E-05	2.57E-05	1.73E-05
4920		5.54E-05	3.46E-05	2.57E-05	1.71E-05
4950		5.12E-05	3.45E-05	2.77E-05	1.79E-05
4980		6.30E-05	3.56E-05	2.64E-05	1.79E-05
5010		5.89E-05	3.66E-05	2.47E-05	1.83E-05
5040		5.64E-05	3.73E-05	2.28E-05	1.64E-05
5070		5.32E-05	3.37E-05	2.61E-05	1.69E-05
5100		6.34E-05	3.43E-05	2.44E-05	1.74E-05
5130		5.84E-05	3.50E-05	2.45E-05	1.72E-05
5160		5.74E-05	3.61E-05	2.69E-05	1.72E-05
5190		5.64E-05	3.74E-05	2.73E-05	1.72E-05
5220		5.79E-05	3.39E-05	2.66E-05	1.68E-05
5250		6.17E-05	3.44E-05	2.69E-05	1.65E-05
5280		5.88E-05	3.46E-05	2.63E-05	1.66E-05
5310		5.60E-05	3.55E-05	2.57E-05	1.67E-05
5340		5.31E-05	3.63E-05	2.53E-05	1.69E-05
5370		5.77E-05	3.12E-05	2.52E-05	1.64E-05
5400		5.61E-05	3.42E-05	2.83E-05	1.65E-05
5430		5.24E-05	3.53E-05	3.05E-05	1.51E-05
5460		6.24E-05	3.56E-05	4.19E-05	(1.50E-05 )
5490		6.05E-05	3.65E-05	(4.18E-05 )	(1.50E-05 )
5520	(6.03E-05 )	(3.64E-05 )	(4.16E-05 )	(1.49E-05 )	
5550	(6.01E-05 )	(3.63E-05 )	(4.15E-05 )	(1.49E-05 )	
5580	(5.99E-05 )	(3.62E-05 )	(4.14E-05 )	(1.49E-05 )	
5610	(5.97E-05 )	(3.60E-05 )	(4.13E-05 )	(1.48E-05 )	
5640	(5.95E-05 )	(3.59E-05 )	(4.11E-05 )	(1.48E-05 )	
5670	(5.93E-05 )	(3.58E-05 )	(4.10E-05 )	(1.47E-05 )	
5700	(5.91E-05 )	(3.57E-05 )	(4.09E-05 )	(1.47E-05 )	
FIRST DATA ALT	300	270	330	870	
LAST DATA ALT	5490	5490	5460	5430	

**FLIGHT NO. C-381**  
**VERTICAL BEAM TRANSMITTANCE FROM GROUND TO ALTITUDE**

ALTITUDE (M)	VERTICAL BEAM TRANSMITTANCE FROM GROUND TO ALTITUDE			
	FILTERS	2	4	3
0	1.00E 00	1.00E 00	1.00E 00	1.00E 00
300	8.40E-01	8.69E-01	9.28E-01	9.48E-01
600	7.03E-01	7.54E-01	8.61E-01	9.00E-01
900	6.14E-01	6.49E-01	7.98E-01	8.56E-01
1200	5.44E-01	5.57E-01	7.42E-01	8.18E-01
1500	5.04E-01	4.95E-01	6.99E-01	7.79E-01
1800	4.74E-01	4.65E-01	6.68E-01	7.53E-01
2100	4.48E-01	4.45E-01	6.51E-01	7.28E-01
2400	4.28E-01	4.28E-01	6.37E-01	7.19E-01
2700	4.09E-01	4.15E-01	6.28E-01	7.13E-01
3000	3.96E-01	4.06E-01	6.23E-01	7.07E-01
3300	3.87E-01	4.01E-01	6.17E-01	7.01E-01
3600	3.79E-01	3.95E-01	6.12E-01	6.96E-01
3900	3.71E-01	3.89E-01	6.07E-01	6.91E-01
4200	3.63E-01	3.84E-01	6.02E-01	6.86E-01
4500	3.56E-01	3.79E-01	5.97E-01	6.82E-01
4800	3.50E-01	3.75E-01	5.93E-01	6.79E-01
5100	3.44E-01	3.71E-01	5.88E-01	6.75E-01
5400	3.38E-01	3.67E-01	5.84E-01	6.72E-01
5700	3.32E-01	3.63E-01	5.77E-01	6.69E-01

**FLIGHT NO. C-381**  
**EQUIVALENT ATTENUATION LENGTH**

(JOB 2677 DATE 03/09/77)  
 DATE 52576 FLIGHT NO. C-381 GROUND LEVEL ALTITUDE (M)= 18

ALTITUDE (M)	EQUIVALENT ATTENUATION LENGTH (M)			
	FILTERS	2	4	3
0	1.69E 03	2.09E 03	3.96E 03	5.53E 03
300	1.72E 03	2.13E 03	4.02E 03	5.61E 03
600	1.70E 03	2.12E 03	4.00E 03	5.68E 03
900	1.84E 03	2.09E 03	4.00E 03	5.77E 03
1200	1.97E 03	2.05E 03	4.02E 03	5.97E 03
1500	2.19E 03	2.13E 03	4.19E 03	6.00E 03
1800	2.41E 03	2.35E 03	4.47E 03	6.34E 03
2100	2.62E 03	2.59E 03	4.90E 03	6.63E 03
2400	2.83E 03	2.83E 03	5.32E 03	7.27E 03
2700	3.02E 03	3.07E 03	5.81E 03	7.97E 03
3000	3.24E 03	3.33E 03	6.33E 03	8.64E 03
3300	3.48E 03	3.61E 03	6.84E 03	9.28E 03
3600	3.71E 03	3.88E 03	7.33E 03	9.92E 03
3900	3.93E 03	4.13E 03	7.81E 03	1.05E 04
4200	4.15E 03	4.39E 03	8.28E 03	1.12E 04
4500	4.36E 03	4.64E 03	8.73E 03	1.18E 04
4800	4.57E 03	4.89E 03	9.18E 03	1.24E 04
5100	4.78E 03	5.14E 03	9.62E 03	1.30E 04
5400	4.98E 03	5.39E 03	1.00E 04	1.36E 04
5700	5.17E 03	5.63E 03	1.04E 04	1.42E 04

FLIGHT C-382 – 26 MAY 1976 – DESCRIPTION OF FLIGHT AND WEATHER CHARACTERISTICS

Filter Identification	Data Interval			Solar Zenith Angle			Maximum Flight Altitude (meters)	Average Terrain Elevation (meters)
	Start (GMT)	End (GMT)	Elapsed (hrs)	Initial ST & LV (degrees)	Solar Transit (degrees)	Final VPRO (degrees)		
2 and 4	0925	1056	1.5	39.4	–	32.3	5430	18

Flight C-382 was a morning flight. There were scattered to broken clouds with multiple layers and deteriorating weather conditions throughout the shortened flight interval. The in-flight pictures indicate clear upper hemispheres at flight levels above 3000 meters (10 000 feet).

The approximate northeast to southwest track was located between Oldenberg and Lathen in north-western Germany. Typical terrain features were heavily cultivated low lying flat farmlands interspersed with occasional dark woods and small towns.

The in-flight observer reported 3/8 stratocumulus with bases at 750 meters (2500 feet) and tops 1200 meters (4000 feet) and 7/8 cirrus at 7500 meters (25000 feet) at take off. By 0930 GMT the lower layer varied from 3/8 to 5/8 along the track and included cumulus, stratocumulus, and altocumulus clouds. At 1005 GMT there was overcast cumulus with cumulonimbus in several quadrants. During the descent at 1053 GMT scattered light rain showers were observed and weather aborted the remainder of the mission.

At Oldenberg, 40 kilometers eastnortheast of the track center point, 3/8 cumulus at 900 meters (3000 feet) and 7/8 stratocumulus at 1500 meters (5000 feet) decreased to 1/8 cumulonimbus at 600 meters (2000 feet) and 7/8 stratocumulus at 1050 meters (3500 feet) by 1244 GMT. Visibility was reported as 11.2 kilometers and a rain shower occurred shortly after noon.

Ahlhorn, 43 kilometers eastsoutheast of the track center point, reported similar cloud conditions with thunderstorm activity from 1144 to 1223 GMT.

Meppen, 42 kilometers southwest of the track center point, reported scattered cumulus at 600 meters (2000 feet) and broken to overcast stratocumulus at 1500 meters (5000 feet). Visibility from 6 to 11 kilometers was occasionally lowered to 2.5 kilometers in rain shower activity.

The radiosonde station at Rheine/Waldhugel was 81 kilometers south and up-stream from the flight track center point.

The surface chart for 1200 GMT shows a cold front extended from near Oslo through eastern Poland and central Italy into the Mediterranean. At 500 millibars there was an open low in the North Sea with northwestern Germany on the leading edge of a trough with moderate southwesterly flow. The airmass was unstable maritime polar.

# FLIGHT NO. C-382

MEPPEN

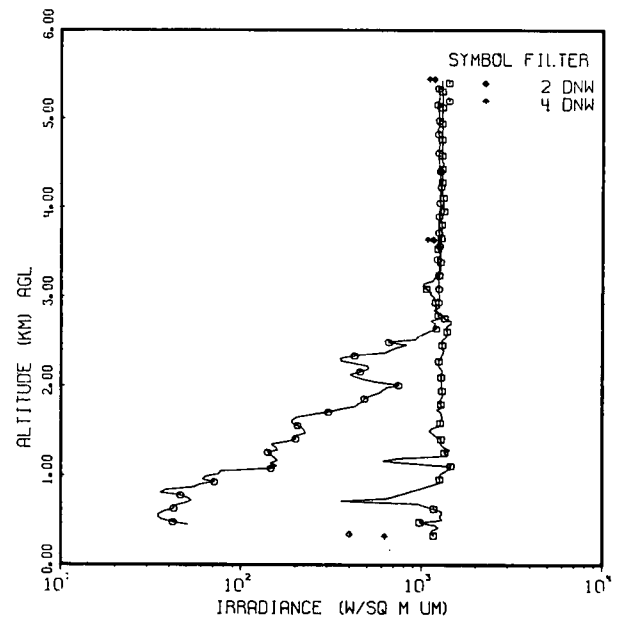
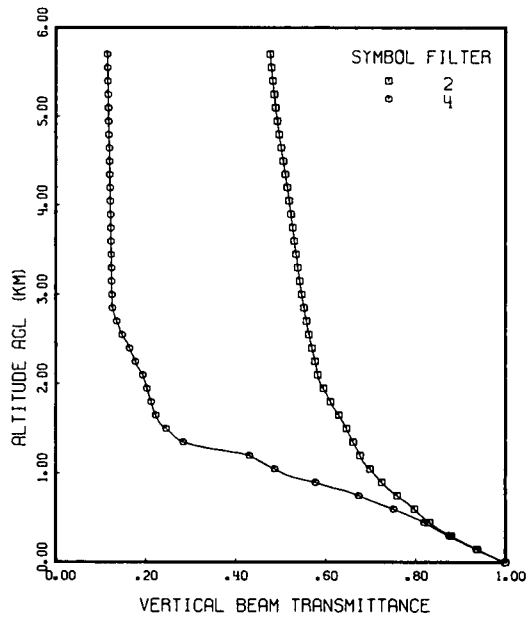
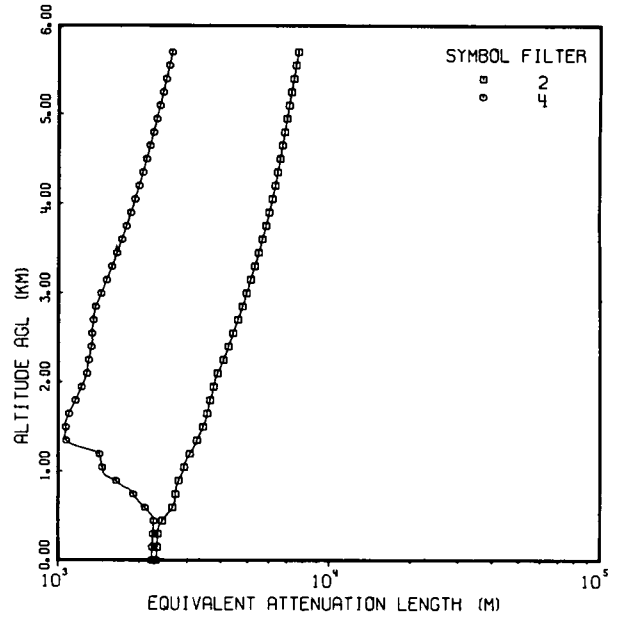
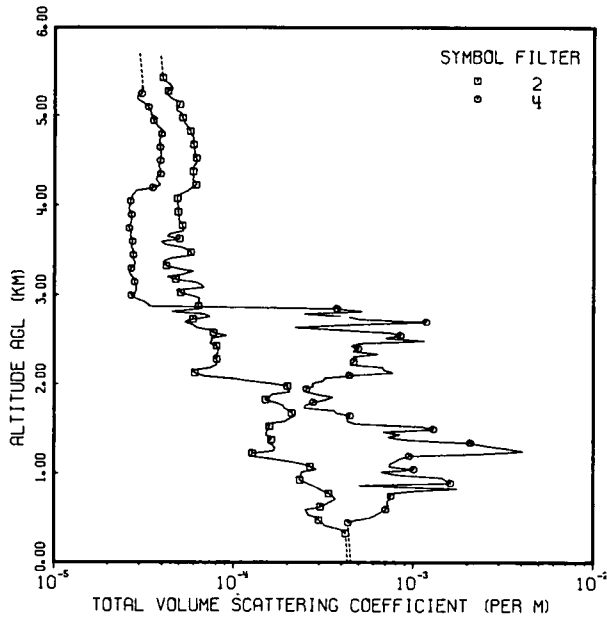

**FLIGHT NO. C-382**  
**TOTAL VOLUME SCATTERING COEFFICIENT**

(JOB 2676 DATE 03/09/77)  
 DATE 52676 FLIGHT NO. C-382 GROUND LEVEL ALTITUDE (M)= 18

ALTITUDE (M)	TOTAL VOLUME SCATTERING COEFFICIENT (PER M)	
	FILTERS 2	4
0	(4.34E-04 )	(4.52E-04 )
30	(4.32E-04 )	(4.50E-04 )
60	(4.31E-04 )	(4.49E-04 )
90	(4.30E-04 )	(4.48E-04 )
120	(4.28E-04 )	(4.47E-04 )
150	(4.27E-04 )	(4.45E-04 )
180	(4.26E-04 )	(4.44E-04 )
210	(4.25E-04 )	(4.43E-04 )
240	(4.24E-04 )	(4.42E-04 )
270	(4.23E-04 )	(4.41E-04 )
300	(4.22E-04 )	(4.40E-04 )
330	4.21E-04	(4.39E-04 )
360	4.13E-04	(4.37E-04 )
390	3.70E-04	(4.36E-04 )
420	3.21E-04	(4.35E-04 )
450	3.13E-04	4.34E-04
480	2.98E-04	4.76E-04
510	2.90E-04	5.79E-04
540	2.60E-04	6.18E-04
570	2.57E-04	6.57E-04
600	2.50E-04	7.02E-04
630	3.04E-04	7.26E-04
660	3.25E-04	7.21E-04
690	3.46E-04	7.09E-04
720	3.70E-04	7.41E-04
750	3.58E-04	7.50E-04
780	3.38E-04	7.21E-04
810	3.17E-04	5.81E-04
840	2.96E-04	1.75E-03
870	2.75E-04	4.99E-04
900	2.54E-04	1.61E-03
930	2.33E-04	1.52E-03
960	2.36E-04	1.44E-03
990	2.36E-04	8.08E-04
1020	2.40E-04	6.58E-04
1050	2.89E-04	1.01E-03
1080	2.65E-04	7.32E-04
1110	2.40E-04	7.39E-04
1140	2.02E-04	7.94E-04
1170	1.60E-04	8.40E-04
1200	1.24E-04	9.47E-04
1230	1.27E-04	2.51E-03
1260	1.67E-04	4.07E-03
1290	1.70E-04	3.30E-03
1320	1.66E-04	2.51E-03
1350	1.55E-04	2.07E-03
1380	1.62E-04	9.36E-04
1410	1.59E-04	7.19E-04
1440	1.50E-04	8.39E-04
1470	1.53E-04	6.77E-04
1500	1.55E-04	1.29E-03

**FLIGHT NO. C-382**  
**TOTAL VOLUME SCATTERING COEFFICIENT**

(JOB 2676 DATE 03/09/77)  
 DATE 52676 FLIGHT NO. C-382 GROUND LEVEL ALTITUDE (M)= 18

ALTITUDE (M)	TOTAL VOLUME SCATTERING COEFFICIENT (PER M)	
	FILTERS 2	4
1530	1.58E-04	1.11E-03
1560	1.53E-04	4.68E-04
1590	1.93E-04	4.28E-04
1620	2.05E-04	4.26E-04
1650	2.17E-04	4.42E-04
1680	2.10E-04	3.71E-04
1710	2.04E-04	3.59E-04
1740	1.91E-04	2.46E-04
1770	1.88E-04	2.51E-04
1800	1.71E-04	2.76E-04
1830	1.50E-04	3.25E-04
1860	1.58E-04	3.55E-04
1890	1.62E-04	2.88E-04
1920	2.04E-04	2.51E-04
1950	2.02E-04	2.54E-04
1980	1.98E-04	2.76E-04
2010	1.66E-04	2.72E-04
2040	1.24E-04	3.15E-04
2070	9.85E-05	3.20E-04
2100	6.69E-05	4.38E-04
2130	6.05E-05	7.65E-04
2160	5.89E-05	6.80E-04
2190	7.47E-05	6.73E-04
2220	8.04E-05	4.44E-04
2250	8.03E-05	4.64E-04
2280	8.02E-05	4.83E-04
2310	7.75E-05	4.61E-04
2340	8.14E-05	6.31E-04
2370	8.18E-05	4.59E-04
2400	8.21E-05	4.92E-04
2430	7.98E-05	4.48E-04
2460	7.31E-05	5.03E-04
2490	7.61E-05	1.15E-03
2520	7.52E-05	7.00E-04
2550	9.08E-05	8.47E-04
2580	7.68E-05	7.40E-04
2610	7.47E-05	4.01E-04
2640	6.18E-05	2.19E-04
2670	5.89E-05	4.53E-04
2700	5.30E-05	1.18E-03
2730	5.90E-05	4.97E-04
2760	7.32E-05	4.28E-04
2790	6.77E-05	2.46E-04
2820	4.49E-05	5.14E-04
2850	6.39E-05	3.74E-04
2880	6.33E-05	3.38E-05
2910	6.34E-05	3.29E-05
2940	6.35E-05	3.11E-05
2970	6.41E-05	2.83E-05
3000	5.77E-05	2.67E-05

**FLIGHT NO. C-382**  
**TOTAL VOLUME SCATTERING COEFFICIENT**

(JOB 2676 DATE 03/C9/77)  
 DATE 52676 FLIGHT NO. C-382 GROUND LEVEL ALTITUDE (M)= 18

ALTITUDE (M)	TOTAL VOLUME SCATTERING COEFFICIENT (PER M)	
	FILTERS 2	4
3030	5.04E-05	2.82E-05
3060	4.78E-05	2.85E-05
3090	6.79E-05	2.85E-05
3120	6.59E-05	2.84E-05
3150	6.08E-05	2.80E-05
3180	4.73E-05	2.82E-05
3210	4.22E-05	2.71E-05
3240	5.30E-05	2.64E-05
3270	5.93E-05	2.61E-05
3300	4.87E-05	2.67E-05
3330	4.18E-05	2.78E-05
3360	4.03E-05	2.81E-05
3390	4.09E-05	2.77E-05
3420	4.51E-05	2.73E-05
3450	5.84E-05	2.74E-05
3480	5.74E-05	2.76E-05
3510	5.52E-05	2.74E-05
3540	5.08E-05	2.68E-05
3570	4.12E-05	2.68E-05
3600	3.91E-05	2.72E-05
3630	4.96E-05	2.73E-05
3660	4.24E-05	2.65E-05
3690	4.47E-05	2.66E-05
3720	5.24E-05	2.66E-05
3750	5.24E-05	2.60E-05
3780	5.15E-05	2.63E-05
3810	5.09E-05	2.67E-05
3840	4.92E-05	2.68E-05
3870	4.94E-05	2.68E-05
3900	4.85E-05	2.68E-05
3930	4.86E-05	2.64E-05
3960	4.93E-05	2.60E-05
3990	4.87E-05	2.61E-05
4020	4.84E-05	2.64E-05
4050	4.83E-05	2.65E-05
4080	4.81E-05	2.69E-05
4110	4.82E-05	2.71E-05
4140	5.17E-05	2.79E-05
4170	5.52E-05	2.86E-05
4200	5.82E-05	3.53E-05
4230	6.12E-05	3.88E-05
4260	6.09E-05	3.78E-05
4290	5.86E-05	3.67E-05
4320	5.93E-05	3.70E-05
4350	5.89E-05	3.89E-05
4380	5.90E-05	3.85E-05
4410	5.88E-05	3.87E-05
4440	5.94E-05	3.79E-05
4470	6.10E-05	3.83E-05
4500	6.17E-05	3.88E-05

**FLIGHT NO. C-382**  
**TOTAL VOLUME SCATTERING COEFFICIENT**

(JOB 2676 DATE 03/C9/77)  
 DATE 52676 FLIGHT NO. C-382 GROUND LEVEL ALTITUDE (M)= 18

ALTITUDE (M)	TOTAL VOLUME SCATTERING COEFFICIENT (PER M)	
	FILTERS 2	4
4530	6.14E-05	3.90E-05
4560	6.00E-05	3.93E-05
4590	6.03E-05	3.91E-05
4620	5.99E-05	3.89E-05
4650	5.96E-05	3.85E-05
4680	5.93E-05	3.85E-05
4710	5.85E-05	3.84E-05
4740	5.89E-05	3.83E-05
4770	5.91E-05	3.88E-05
4800	5.71E-05	3.93E-05
4830	5.68E-05	4.03E-05
4860	5.64E-05	3.86E-05
4890	5.47E-05	3.73E-05
4920	5.30E-05	3.63E-05
4950	5.26E-05	3.54E-05
4980	5.15E-05	3.72E-05
5010	5.10E-05	3.44E-05
5040	5.05E-05	3.46E-05
5070	4.71E-05	3.41E-05
5100	4.83E-05	3.32E-05
5130	4.95E-05	3.23E-05
5160	4.97E-05	3.06E-05
5190	4.52E-05	2.89E-05
5220	4.35E-05	2.86E-05
5250	4.17E-05	3.05E-05
5280	4.27E-05	3.09E-05
5310	4.55E-05	3.08E-05
5340	4.43E-05	3.08E-05
5370	4.30E-05	(3.07E-05 )
5400	4.01E-05	(3.06E-05 )
5430	3.98E-05	(3.05E-05 )
5460	(3.96E-05 )	(3.04E-05 )
5490	(3.95E-05 )	(3.03E-05 )
5520	(3.94E-05 )	(3.02E-05 )
5550	(3.93E-05 )	(3.01E-05 )
5580	(3.91E-05 )	(3.00E-05 )
5610	(3.90E-05 )	(2.99E-05 )
5640	(3.89E-05 )	(2.98E-05 )
5670	(3.88E-05 )	(2.97E-05 )
5700	(3.86E-05 )	(2.96E-05 )
FIRST DATA ALT	330	450
LAST DATA ALT	5430	5340

**FLIGHT NO. C-382**  
**VERTICAL BEAM TRANSMITTANCE FROM GROUND TO ALTITUDE**

ALTITUDE (M)	VERTICAL BEAM TRANSMITTANCE FROM GROUND TO ALTITUDE	
	FILTERS 2	4
0	1.00E 00	1.00E 00
300	8.80E-01	8.75E-01
600	7.97E-01	7.51E-01
900	7.25E-01	5.78E-01
1200	6.77E-01	4.30E-01
1500	6.46E-01	2.45E-01
1800	6.10E-01	2.12E-01
2100	5.82E-01	1.94E-01
2400	5.69E-01	1.64E-01
2700	5.57E-01	1.36E-01
3000	5.47E-01	1.25E-01
3300	5.38E-01	1.24E-01
3600	5.30E-01	1.23E-01
3900	5.22E-01	1.22E-01
4200	5.15E-01	1.21E-01
4500	5.05E-01	1.19E-01
4800	4.96E-01	1.18E-01
5100	4.89E-01	1.17E-01
5400	4.82E-01	1.16E-01
5700	4.77E-01	1.15E-01

**FLIGHT NO. C-382**  
**EQUIVALENT ATTENUATION LENGTH**

(JOB 2676 DATE 03/09/77)  
 DATE 52676 FLIGHT NO. C-382 GROUND LEVEL ALTITUDE (M)= 18

ALTITUDE (M)	EQUIVALENT ATTENUATION LENGTH (M)	
	FILTERS 2	4
0	2.31E 03	2.21E 03
300	2.34E 03	2.24E 03
600	2.65E 03	2.10E 03
900	2.80E 03	1.64E 03
1200	3.07E 03	1.42E 03
1500	3.43E 03	1.07E 03
1800	3.65E 03	1.16E 03
2100	3.88E 03	1.28E 03
2400	4.26E 03	1.33E 03
2700	4.61E 03	1.35E 03
3000	4.97E 03	1.44E 03
3300	5.32E 03	1.58E 03
3600	5.67E 03	1.72E 03
3900	6.01E 03	1.85E 03
4200	6.32E 03	1.99E 03
4500	6.60E 03	2.12E 03
4800	6.85E 03	2.25E 03
5100	7.12E 03	2.38E 03
5400	7.40E 03	2.50E 03
5700	7.69E 03	2.63E 03

## 8. DATA INTERPRETATION AND EVALUATION

### 8.1 METEOROLOGICAL DATA

The basic discussion of meteorological conditions, as presented in Section 6 and summarized with each flight description, is based upon meteorological data from a number of sources. There are hourly observations from two or more weather stations for every flight. There are in-flight observations by an on-board meteorologist for all but one flight. In addition, there are in-flight hemispherical pictures of the sky. In cases of discrepancy between the various cloud descriptions, the pictures were considered primary since they were concurrent with the actual data taking.

#### CLOUD CONDITIONS

The airborne pictures which documented the cloud conditions during each flight were described in Table 7.2. Their general features are summarized in Table 8.1. The upper sky descriptions are divided into three categories.

**Table 8.1**  
Airborne Hemispherical Picture Summary

Category	Description	Flights
1	Cloud free at all altitudes	C-376 C-379
2	Scattered clouds low altitude, clear high altitude	C-372 C-377 (Filters 2 & 3) C-381 C-382
3	Partial clouds or overcast at all altitudes	C-373 C-377 (Filters 4 & 5) C-378

## TEMPERATURE

The temperature measurements were made using the AN/AMQ-17 aerograph set. The graphs of temperature in Fig. 6-2 indicate reasonable agreement between the airborne temperatures and the radiosonde temperatures in view of the time and spatial differences between the two measurements. Flight C-372 is the only case where the radiosonde station is fairly close, upwind of the track, and its data are contemporary with the flight. On all the other flights the RAOB launching was either distant from the flight track, and/or downwind, and/or not concurrent with the flight. Therefore the differences between these airborne and radiosonde temperatures may be due to differences in the bodies of air.

For most of the flights the graphs in Fig. 6-2 show a relatively stable temperature function with altitude over the flight time interval. This is indicated by the general repeatability of the temperatures during each profile time interval. The exception is Flight C-373 where the temperatures are more variable with time in the altitude interval 2.5 to 4 kilometers.

There were eight project flights, listed in Table 8.1, accomplished during April and May 1976 at tracks from 50.93°N to 58.68°N latitude. Temperature data measured during these flights can be profitably compared to data from U.S. Standard Atmosphere Supplements. To facilitate this comparison, the average temperature profile measured during each of the eight flights has been superimposed on a graph of the temperatures appropriate for 45° and 60°N latitudes in Fig. 8-1. The anticipated spring temperature profile should lie between the 60°N latitude, January and July profiles, and near the profile for 45°N latitude in spring/fall as specified in the U.S. Standard Atmosphere Supplements (1966). The altitude scale in Fig. 8-1 is kilometers above mean sea level (MSL), and the ground elevation at the test sites range from 0 meters in Denmark to 60 meters in England.

The temperatures for all but one of the flights lie between the curves for 60°N, January and July, and above and below the temperatures for 45°N spring/fall. This is reasonable for late spring at latitudes intermediate to the 45°N and 60°N latitudes.

## RELATIVE HUMIDITY

Relative humidity was computed from the measured values of ambient temperature and dewpoint temperature. The dewpoint temperatures were measured using the modified Cambridge hygrometer system [Duntley, *et al.* (1972c)] and are the second set of data reported since the modification was completed.

No relative humidities were given in the hourly reports for the local weather stations. Therefore the only comparison that can be made is to the radiosonde data on relative humidity. Again, on all the flights but C-372, the radiosonde launching station was either distant from the flight track, and/or downwind, and/or not concurrent with the flight. Therefore any differences depicted in Fig. 6-3 between these airborne and radiosonde relative humidities may be due to real differences in the two bodies of air. The airborne relative humidity measurements for C-372 span the radiosonde values at 6 of the 9 altitudes for which both measurements are available. Two of the remaining are at altitudes where the relative humidity is changing rapidly and the differences are small. The only real difference is for the one radio-

sonde point at 5.5 kilometers and it compares as well to the relative humidity measured during the filter 4 profile, as do the humidities measured during the filter 4 and filter 2 profiles. Thus, we can conclude the airborne and radiosonde relative humidity measurements are reasonably comparable. Any differences are probably real differences in time and space.

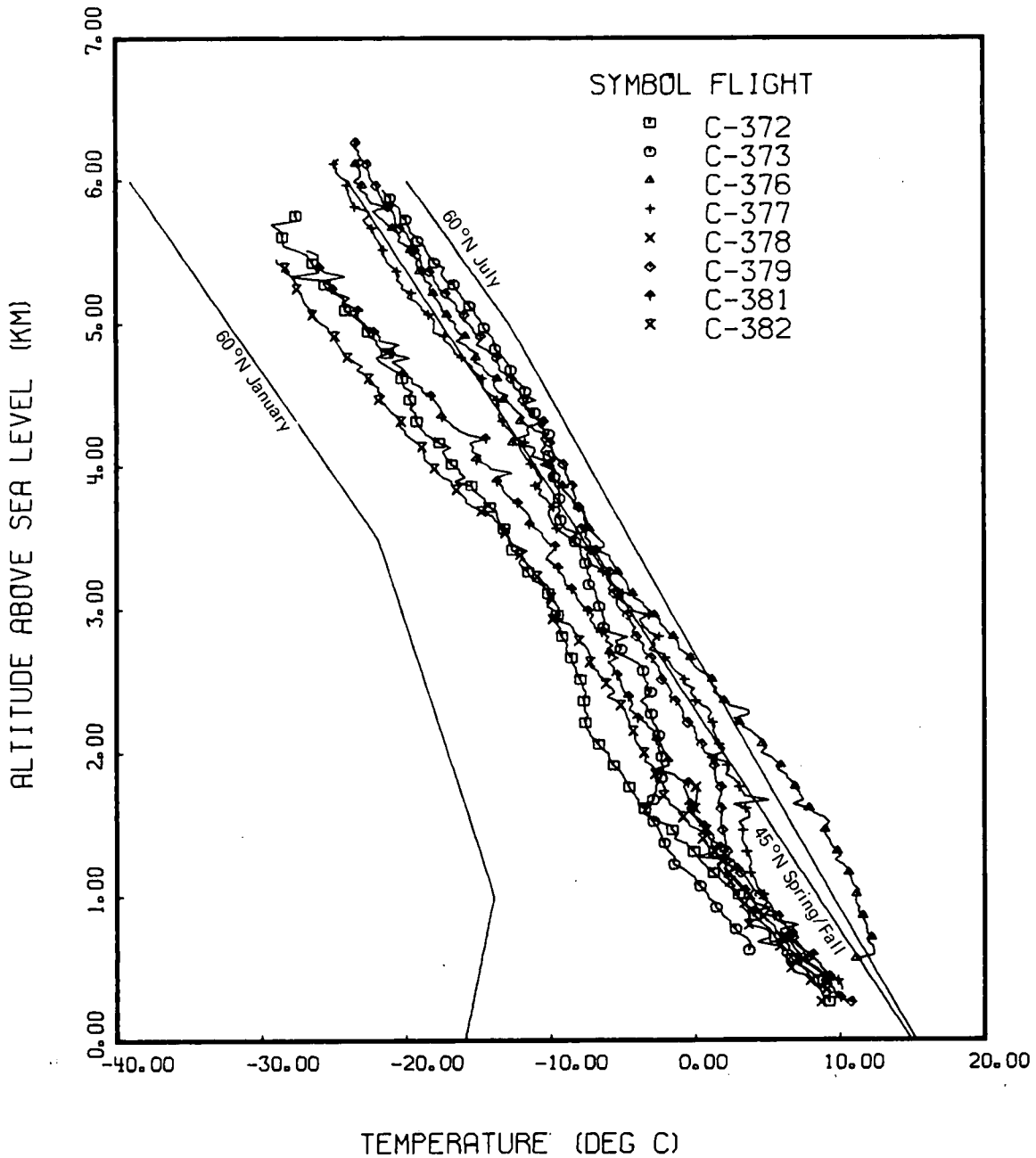

Fig. 8-1. Temperature for OPAQUE I Flights 12 April to 26 May 1976 Compared to Temperature from U.S. Standard Atmosphere Supplements.

The graphs in Fig. 6-3 indicate that relative humidity is less stable over the time interval of the flight than is temperature. The general structure with altitude is usually repeated for the four filter profiles, but the range of values at any one altitude is often quite large. Particularly noticeable are the wide range of relative humidity values for Flight C-373 from 3 to 4.5 kilometers, Flight C-379 from 4.2 to 5.8 kilometers, and Flight C-377 from 1.2 to 3.4 kilometers.

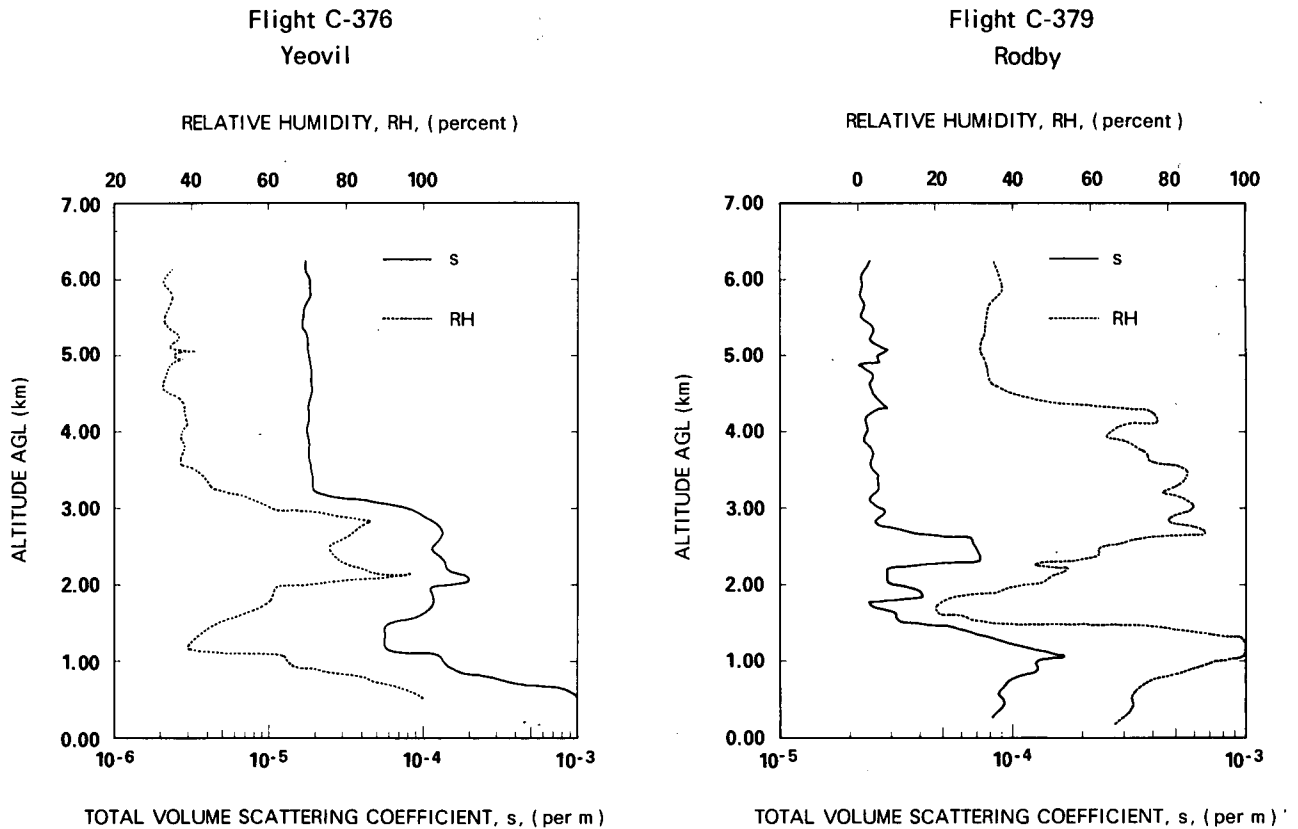

Fig. 8-2. Comparison of the photopic scattering coefficient and relative humidity profiles as measured during flights C-376 and C-379.

In order to more conveniently assess the degree of similarity, or the lack thereof, between the relative humidity profiles presented in Fig. 6-3 and the total volume scattering coefficient profiles presented in Section 7, one might prefer the composite plots illustrated in Fig. 8-2. In these manually generated overlays one can readily determine the degree to which the two plots exhibit the same or similar structural characteristics. These paired plots of simultaneously recorded data sets represent an optional display form currently under development and should prove useful in guiding the analyst toward the goal of determining a more clearly defined relationship between the measured optical and meteorological properties of the atmosphere. It is anticipated that the increased use of these displays will accelerate our ability to select flights whose optical and meteorological characteristics are thoroughly enough documented to enable their use in firmly establishing their linking relationships.

The examples shown in Fig. 8-2 were selected from the thirty two pairs, i.e., eight flight profiles in each of four spectral bands generated during OPAQUE I. They were chosen to illustrate two contrasting situations: One, where the structural similarities between the scattering coefficient and relative humidity profiles were high throughout the entire altitude interval, and two where the similarities were high at the lower altitudes but were inconsistent at altitudes above the primary haze layers.

## 8.2 AIRBORNE RADIOMETRIC DATA

### TOTAL VOLUME SCATTERING COEFFICIENT

During the Project OPAQUE I deployment, the volume scattering function  $\sigma(z,\beta)$  measurements at 150 degrees at high altitude were often greater than volume scattering function measurements at 30 degrees. Subsequent to the deployment, it was determined visually that the problem was stray light entering the telescope at 150 degrees. Modifications to the light trap at  $\beta=150^\circ$  and addition of a baffle near the light exit port essentially eliminated the problem. The question remained, did the stray light near the 150-degree scattering angle affect the total volume scattering coefficient measurements during OPAQUE I, and if so, could the data be corrected?

*Evidence of Stray Light in Total Volume Scattering Coefficient Data.* There was no reason to question the validity of the volume scattering function data for 30 degrees scattering angle. Therefore one means of evaluating the total volume scattering coefficient was to establish an expected relationship between the total volume scattering coefficient and the volume scattering function.

Ground level photopic volume scattering function data for a large range of total volume scattering coefficients were classified by Barteneva (1960) into ten major classes. She presented values of proportional volume scattering function  $\sigma(\beta)/s$  for each of these classes and a range of total volume scattering coefficients applicable to each class. Table 8.2 presents the median values of total volume scattering coefficient for each of the gradual classes (the steep classes included the fog cases which are less applicable to the airborne data). Also included in Table 8.2 are the proportional volume scattering function values for 30 and 150 degrees. These values are depicted as curves labeled Barteneva in Fig. 8-3 which is a graph of proportional volume scattering function versus total volume scattering coefficient.

Measurements of proportional volume scattering function for 30 to 150 degrees and total volume scattering coefficient were made during various deployments from 1970 through 1974. In order to compare these data to the Barteneva values it is first necessary to compute an equivalent ground-based total volume scattering coefficient by multiplying by the density ratio  $\rho(0)/\rho(z)$ ,

$$s(0) = s(z) \rho(0)/\rho(z) \quad (8.1)$$

The density affects the total volume scattering coefficient and the volume scattering function equally so the proportional volume scattering function is applicable to ground level as well as at altitude. Values of proportional volume scattering function for 30 and 150 degrees are graphed as a function of equivalent ground level total volume scattering coefficient in Fig. 8-3 for the pseudo-photopic filter mean wavelength 557 nanometers for five deployments. In chronological order of deployment they are HAVEN VIEW I

Table 8.2

Values of Median Total Volume Scattering Coefficient and Proportional Scattering at 30 and 150 degrees from Barteneva (1960)

Scattering Function Class	Median Total Volume Scattering Coefficient $s(0)$ per meter	Proportional Volume Scattering Function $\sigma(0, \beta) / s(0)$	
		30 degrees	150 degrees
Rayleigh	1.15E-5	0.105	0.105
1	1.36E-5	0.105	0.104
2	2.15E-5	0.162	0.094
3	3.00E-5	0.196	0.0663
4	5.02E-5	0.234	0.0467
5	1.00E-4	0.269	0.0317
6	2.51E-4	0.295	0.0206
7	5.02E-4	0.299	0.0159
8	1.31E-3	0.302	0.0115

in southern Germany, April through June, 1970, reported in Duntley, *et al.* (1972a); ATOM in central New Mexico, October and November, 1970, reported in Duntley, *et al.* (1972b); METRO in southern Illinois, August 1971, reported in Duntley, *et al.* (1973 and 1974); HAVEN VIEW II in northern Germany, May and June, 1973, reported in Duntley, *et al.* (1976); and SEEKVAL in western Washington, July 1974, reported in Duntley, *et al.* (1975a). These data are for the straight and level elements of each flight since that is when the volume scattering function data are measured. These data were not included in the cited reports although they were used in the derivation of the path radiance data which were reported.

The data measured on the five deployments for the 150-degree scattering angle compare extremely well to the Barteneva curve. The data for the 30-degree scattering angle do not compare as well, but except for the SEEKVAL and ATOM data, are always above 0.1.

A similar graph of the OPAQUE I data for the pseudo-photopic filter 4 mean wavelength 557 nanometers is given in Fig. 8-4. The equivalent total volume scattering coefficient for ground level  $s(0)$  was first computed using Eq. 8.1 as before. The Barteneva curves have also been superimposed on Fig. 8-4 to simplify the analysis. The data in Fig. 8-4 illustrate the stray light error in the volume scattering function data at 150 degrees for OPAQUE I. They show the crossover of the data for 30 degrees and 150 degrees for the low values of total volume scattering coefficient which were encountered at high altitude.

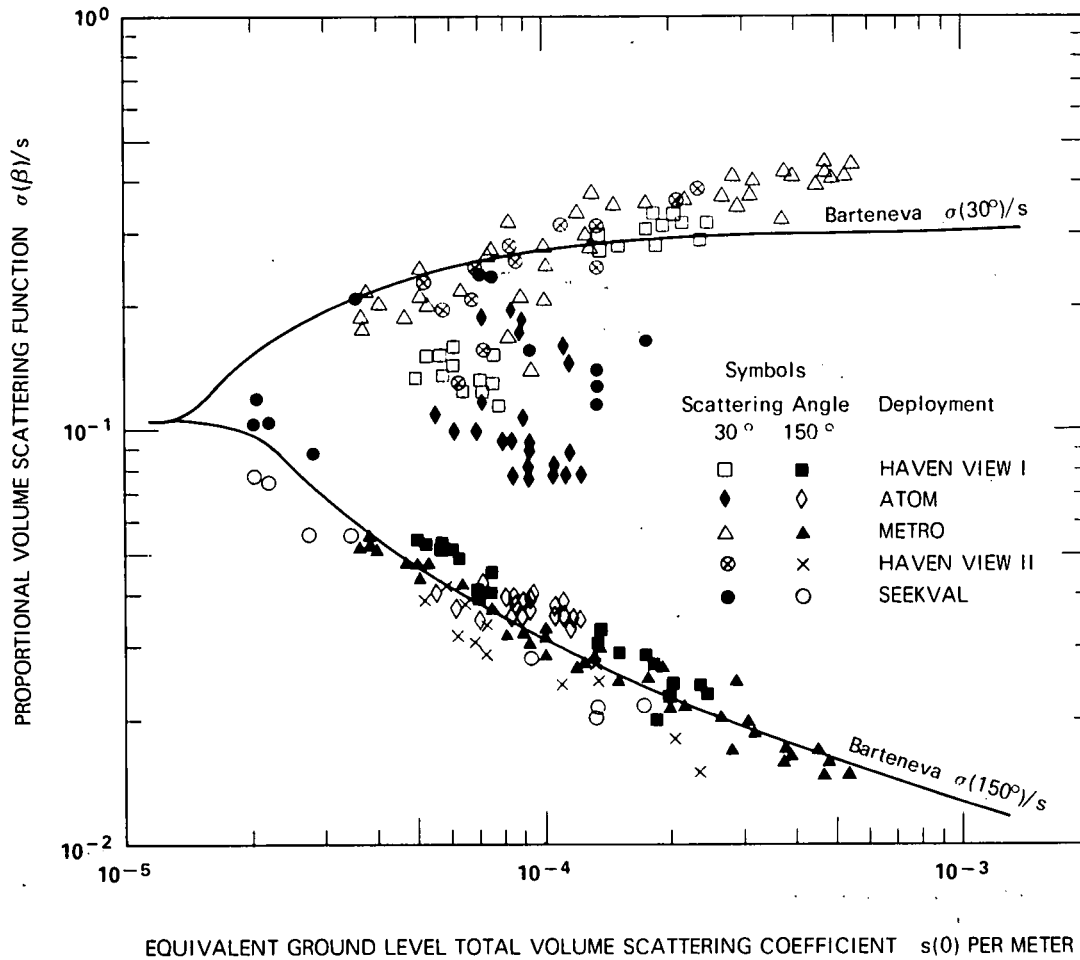

Fig. 8-3. Proportional Volume Scattering Function Related to Equivalent Ground Level Total Volume Scattering Coefficient for the Photopic Barteneva Classes and for the Pseudo-Photopic Filter Mean Wavelength 557 Nanometers for Five Deployments.

In Fig. 8-4 the proportional volume scattering values for 30 degrees compare well to the Barteneva curve at high values of total volume scattering coefficient but depart markedly at low values and the relationship is a fairly clear function not as random as in Fig. 8-3. Since the directional scattering at 30 degrees is considered not in error, then the function can best be explained by an added stray light component to the total volume scattering coefficient measurement.

*Derivation of the Correction to the Total Volume Scattering Coefficient.* Any stray light component in the measurements at large scattering angles would be expected to add a component to the measurement of irradiance of the scattered light  $_s H$  but not add significantly to the measurement of the calibration target  $_r H$ . The measured scattered light  $_s H_m$  might be expressed thus as

$$_s H_m = _s H + P_r H, \quad (8.2)$$

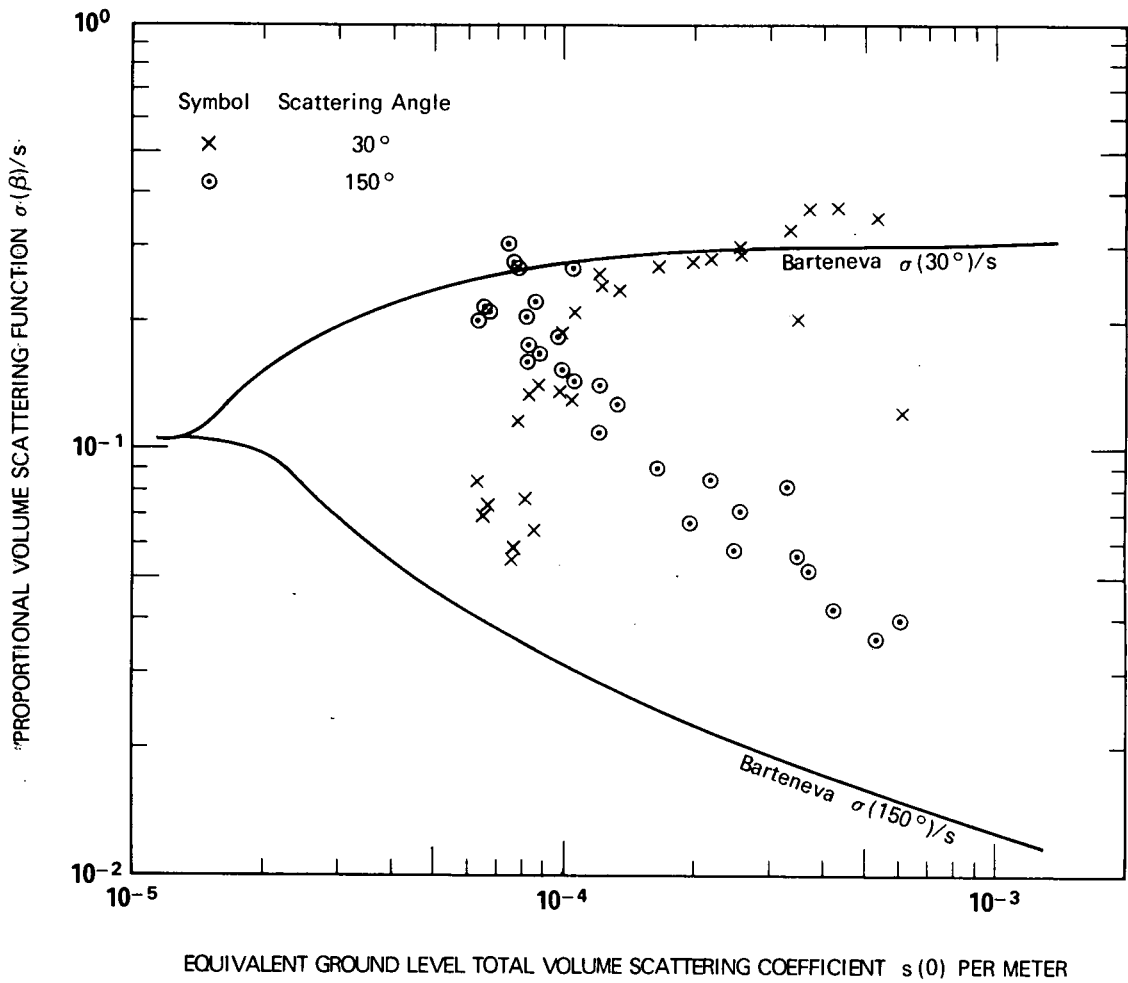

Fig. 8-4. Measured Proportional Volume Scattering Function and Equivalent Ground Level Total Volume Scattering Coefficient for Filter 4 Pseudo-Photopic Filter Mean Wavelength 557 Nanometers for OPAQUE I.

where  $rH$  is a measure of the intensity of the projector light and the constant  $P$  indicates that some constant proportion of that light is reflected toward the irradiator and added to the scattered light  $sH$ . The total volume scattering coefficient  $s(z)$  is computed from the ratio of the irradiance of the scattered light to the irradiance from the calibration target times a calibration constant  $K$ ,

$$s(z) = \frac{sH}{rH} K \quad (8.3)$$

Then, combining Eqs. 8.2 and 8.3 and rearranging we have

$$s(z) = \frac{sH_m}{rH} K - PK = s_m(z) - C \quad (8.4)$$

where  $C$  is equal to  $PK$ . The  $C$  is the constant error due to stray light which has been added to the measured total volume scattering coefficient  $s_m(z)$ . Thus, by subtracting a constant  $C$  from the measurements, the true value can be recovered or conversely the correction  $C$  may be obtained from

$$C = s_m(z) - s(z) \quad (8.5)$$

To get a clearer picture of this relationship, the total volume scattering coefficient measurement  $s(z)$  was graphed as a function of volume scattering function at 30 degrees in Fig. 8.5 for the OPAQUE I Filter 4 (pseudo-photopic). The data are given as the symbol  $+$ . Although there is some dispersion at the higher values, the relationship is fairly clear cut at the lower values, where the constant has the most effect. The curve for the Barteneva data is superimposed on Fig. 8-5. The values for the volume scattering function at 30 degrees for the Barteneva curve were obtained by multiplying the proportional values by the total volume scattering coefficients in Table 8.2. The most accurate value for the constant  $C$  would be derived from the lowest values of total volume scattering coefficient. The lowest values are from Flights C-376 and C-377 at the highest straight and level altitude. The average constant based on these two data is  $2.37E-5$ . The second curve in Fig. 8-5 designated by the symbol  $\odot$  illustrates the fit

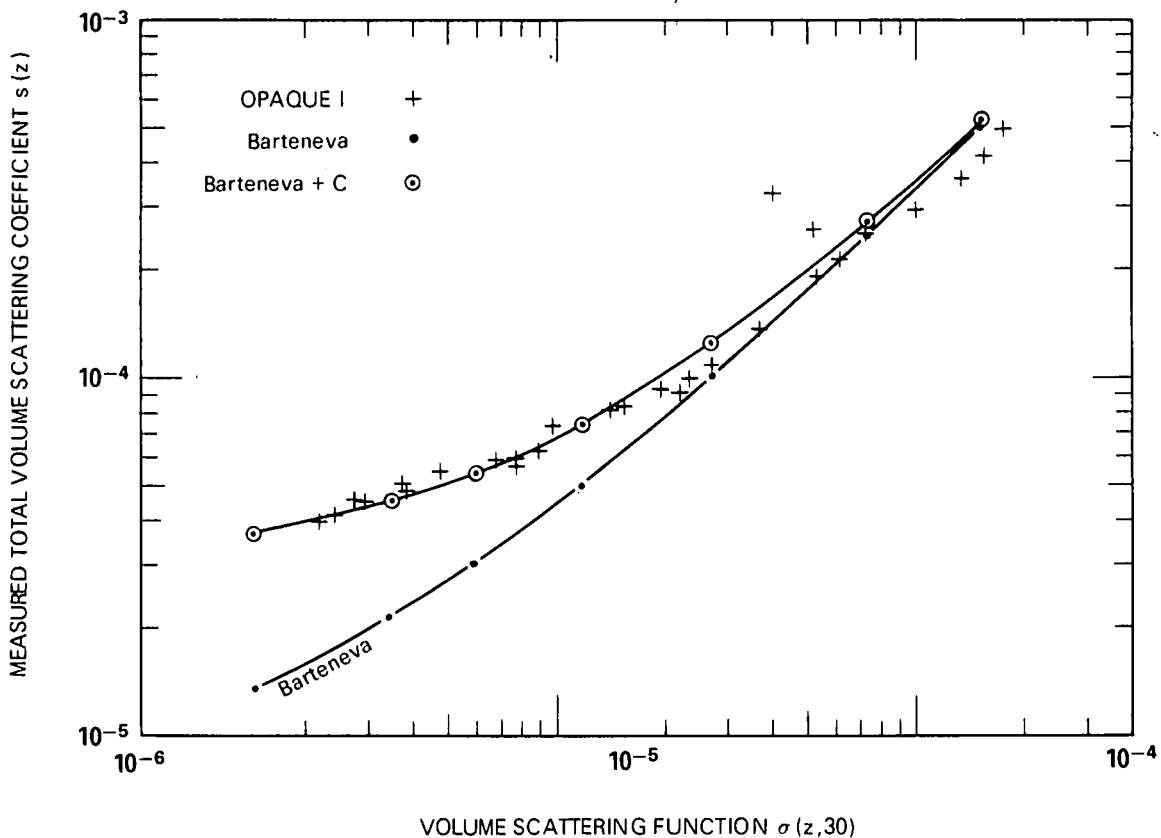

Fig. 8-5. Total Volume Scattering Coefficient as a Function of Volume Scattering Function at 30 Degrees for OPAQUE I Filter 4 Pseudo-Photopic Mean Wavelength 557 Nanometers.

of all the data to the equation  $s(z)_m = s_B s(0) + C$  where  $s_B s(0)$  is the Barteneva total volume scattering coefficient from Table 8.2. This curve fits the measured data quite well at low values.

The derivation of the constant  $C$  was deliberately based on the relationship of the measured  $s(z)$  versus  $\sigma(z, 30^\circ)$  rather than the computed equivalent ground level values because this latter relationship shows more dispersion at the low values making it harder to obtain a correction constant. In addition, the described method resulted in a smaller value for the corrective constant which is advantageous, since it is more dangerous to over-correct using a subtractive correction than to under-correct.

To further illustrate the effect of using this subtractive constant, the corrected values of total volume scattering coefficient were computed using Eq. 8.4, then the corrected equivalent ground level values and the corrected proportional scattering function for 30 degrees were computed. These values are graphed in Fig. 8-6 which can be compared to the uncorrected values in Fig. 8-4. The higher values do not change much but at the lower end of the curve, all proportional values now exceed 0.1 and the dispersion looks similar to the historical data graphed in Fig. 8-3.

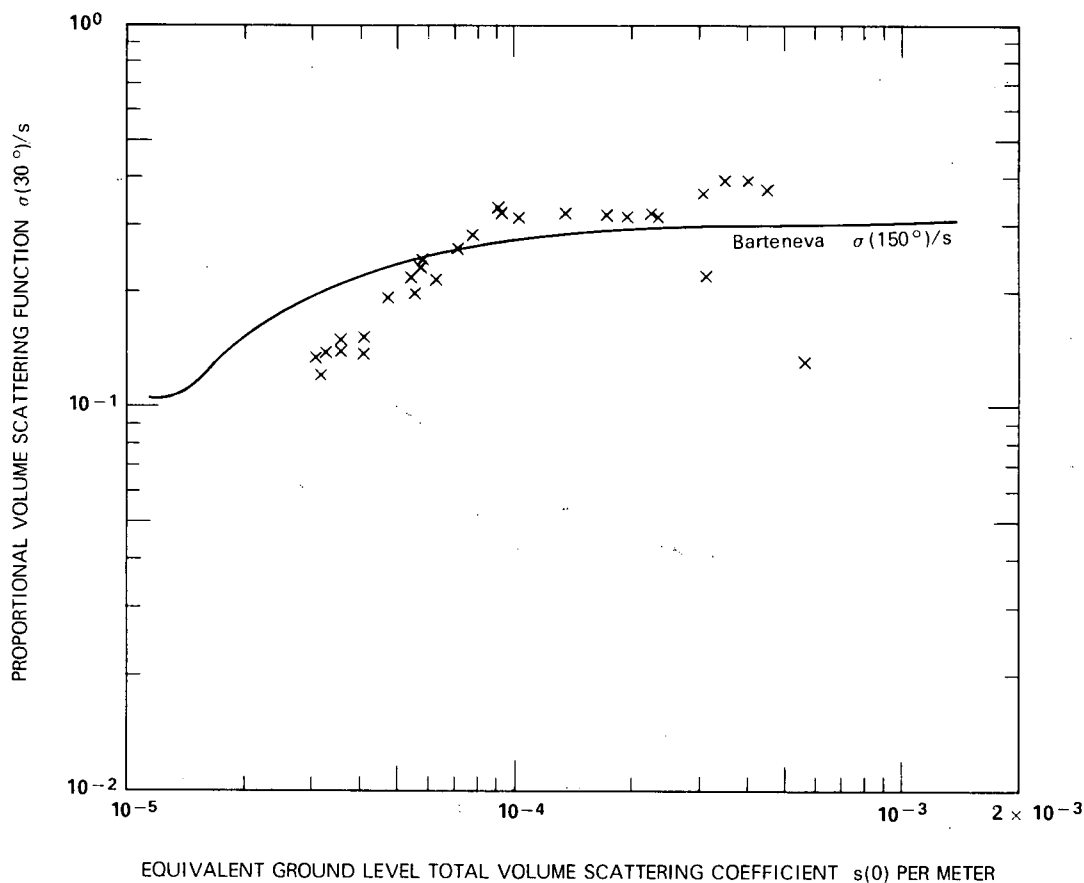

Fig. 8-6. Corrected Proportional Volume Scattering Function and Corrected Equivalent Ground Level Total Volume Scattering Coefficient for Filter 4 Pseudo-Photopic OPAQUE I.

*Application of Corrective Method to Nonphotopic Filters.* During OPAQUE I, nephelometer measurements were made in four spectral filters. The three filters in addition to Filter 4 were Filter 2 mean wavelength 478 nanometers, Filter 3 mean wavelength 664 nanometers, and Filter 5 mean wavelength 765 nanometers. Measurements of proportional volume scattering function for 30 and 150 degrees and total volume scattering coefficient in these spectral bands are available from four deployments: HAVEN VIEW I, ATOM, METRO, and HAVEN VIEW II. Values of equivalent ground level total volume scattering coefficient were computed using Eq. 8.1 for these three filters and graphed in a form similar to Fig. 8-3. The graph of proportional volume scattering function versus equivalent ground level total volume scattering coefficient for Filter 2 mean wavelength 478 nanometers is given in Fig. 8-7. The similarity between the graphs for the different filters is striking, in fact, they can all be superimposed on one graph by adjusting the horizontal scales. If each of the sets of data were graphed as a function of the ratio of the total volume scattering coefficient divided by the Rayleigh total volume scattering coefficient  $s(0)/_R s(0)$  rather than  $s(0)$ , they would all lie on one curve. Thus the Barteneva curve could be superimposed on each graph by first computing the ratio  $s(0)/_R s(0)$  for the photopic Barteneva data and then multiplying by the Rayleigh total volume scattering coefficient  $_R s(0)$  for each filter. These values are given in Table 8.3 and graphed for Filter 2 in Fig. 8-7.

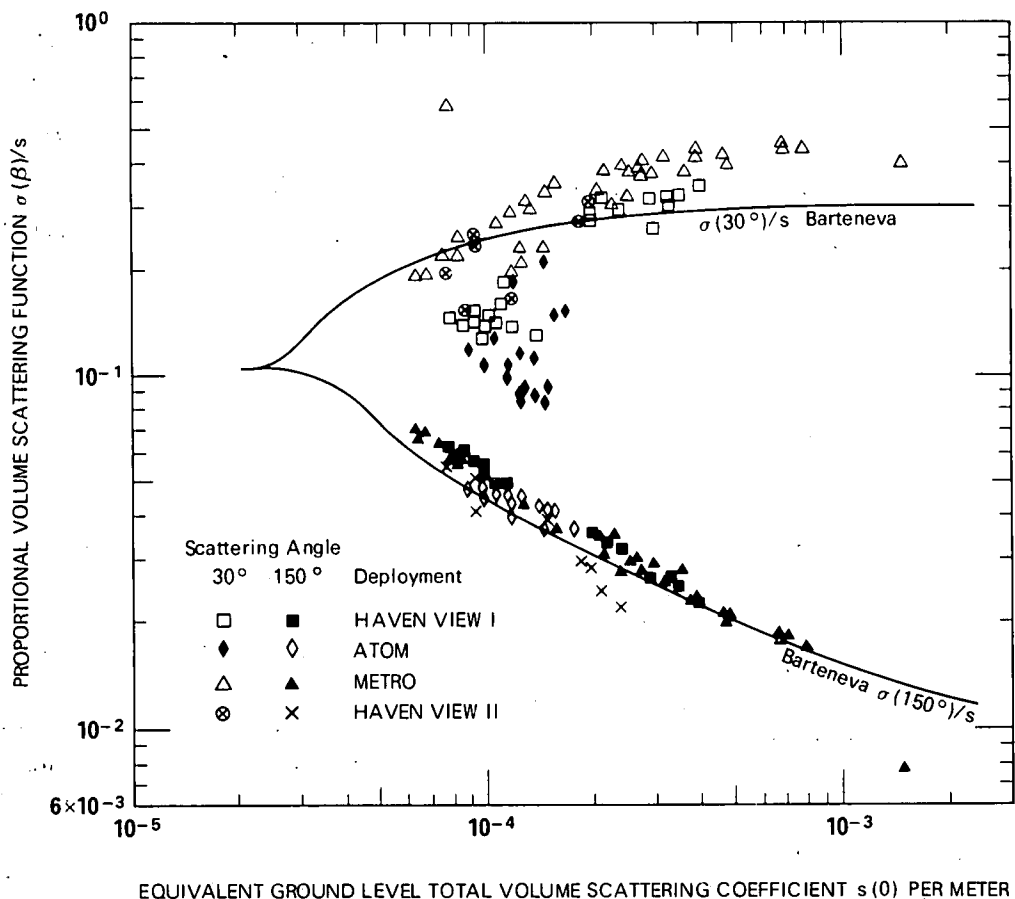

Fig. 8-7. Proportional Volume Scattering Function Related to Equivalent Ground Level Total Volume Scattering Coefficient for Filter 2 Mean Wavelength 478 Nanometers for Four Deployments.

Thus, a procedure directly analogous to the procedure described above for obtaining the corrective constant for Filter 4, could be applied to the OPAQUE I data for each of the other three filters. The corrective constants so derived were 2.99E-5 for Filter 2 mean wavelength 478 nanometers, 1.79E-5 for Filter 3 mean wavelength 664 nanometers, and 1.40E-5 for Filter 5 mean wavelength 765 nanometers. The total volume scattering coefficient data reported herein have been corrected by these constants.

**Table 8.3**

Values of the Ratio of Total Volume Scattering Coefficient to Rayleigh Scattering, and Total Volume Scattering Coefficient for Filters 2, 3, and 5, Based on the Barteneva (1960) Data

Scattering Function Class	Ratio $s(0)/_R s(0)$	Total Volume Scattering Coefficient $s(0)$ Per Meter		
		Filter 2 Mean Wavelength 478	Filter 3 Mean Wavelength 664	Filter 5 Mean Wavelength 765
Rayleigh	1.0	2.07E-5	5.41E-6	3.08E-6
1	1.18	2.44E-5	6.38E-6	3.63E-6
2	1.87	3.87E-5	1.01E-5	5.76E-6
3	2.61	5.40E-5	1.41E-5	8.04E-6
4	4.37	9.05E-5	2.36E-5	1.35E-5
5	8.70	1.80E-4	4.71E-5	2.68E-5
6	21.8	4.51E-4	1.18E-4	6.71E-5
7	43.7	9.05E-4	2.36E-4	1.35E-4
8	114.0	2.36E-3	6.17E-4	3.51E-4

*General Evaluation.* The data reported for total volume scattering coefficient were measured during the vertical profile flight elements. The flight pattern most generally followed was a (2+4) profile, two filters at four straight and level altitudes, with the vertical profile during ascent for the first filter, and during descent in the second filter. This flight pattern was illustrated in Fig. 4-1. For this pattern the average elapsed time between start of the first measurement and end of final measurement during ascent was 76 minutes, and average time during descent was 13 minutes. Five of the flights had two such profiles. These were Flights C-372, C-373, C-376, C-377, and C-379. The first profile for Flight C-381 also followed this pattern. The second profile for Flight C-381 and the only profile for Flight C-382 followed a (2+3) pattern, two filters at three straight and level altitudes with an average elapsed time during ascent of 58 minutes and 13 minutes during descent. Flight C-378 had two profiles following a (2+2) pattern, two filters at two altitudes with an average elapsed time during ascent of 20 minutes and during descent of 5 minutes.

On all flights, it was possible to take the airborne VPRO data down to at least 870 meters and occasionally as low as 270 meters. No ground-level measurements of total volume scattering coefficient were made so the data have been extrapolated downward to ground level. The data have also been extrapolated upward to the nearest 300-meter altitude increment. These extrapolations upward and downward are based upon the density ratios of the U.S. Standard Atmosphere, 1962 (equivalent to the 45°N Spring/Fall). The extrapolations appear on the graphs of total volume scattering coefficient as a slightly slanting dashed line. No upward extrapolations are visible on the graphs for Flight C-378, filters 2 and 3, and Flight C-379, filters 2 and 3, since for these cases there is either no upward extrapolation or the extrapolation is for no more than 30 meters.

The extrapolations both upward and downward follow the general trend of the data in about half of the cases. The extrapolations downward are particularly questionable for Flights C-376, C-379, and C-382 where the low altitude data are varying erratically with altitude and not in the usual order by filter. It should be noted that even though the low altitude data and the extrapolation downward for filter 4, flight C-376 exceed the maximum plottable values as shown in Section 7.3, the tabular entries for these data points are complete down to ground level. The extrapolations upward for flights C-373 and C-378 are particularly questionable due to the marked atmospheric instability at the top VPRO altitude.

For simultaneous data, the order of the scattering coefficient data by filter generally should be the inverse of the mean wavelength of the filters, i.e.,  $s(\text{filter } 2) > s(4) > s(3) > s(5)$ . Although the data were not simultaneous, the data above 3 kilometers for all the flights but Flight C-373 tend to follow this order. The high altitude data for Flight C-373 and all the low altitude data are much less consistent by filter, indicating a less homogeneous aerosol layer and a lack of aerosol stability with time.

To more easily compare the scattering characteristics of the flights, the filter 4 (pseudo-photopic) total volume scattering coefficient profiles for each flight have been graphed in Fig. 8-8. Except for Flight C-373, the flights with high altitude data tend to show a fairly clear layer above 3 kilometers in the total volume scattering coefficient range of  $1.5$  to  $6.5E-5$  per meter and one or more haze layers at the lower altitudes. Similar graphs of data for April through June, 1970 (HAVEN VIEW I) at the flight track near Memmingen in southern Germany and for May-June, 1973 (HAVEN VIEW II) at the flight track near Meppen in northern Germany are available in Duntley, *et al.* (1976), Figs. 8-2 and 8-4. The HAVEN VIEW I graph showed the haze layer ending at 2 kilometers and the range of the upper altitude data to be narrower,  $3.5$  to  $6.5E-5$  per meter. Also, the low altitude haze for HAVEN VIEW I seemed to have only one layer, and the range was narrower with a maximum value of  $5E-4$  per meter compared to  $4E-3$  for OPAQUE I. The HAVEN VIEW II graph was for low altitude data below clouds; that composite graph indicated a fairly uniform haze layer below 1.2 kilometers for each flight in the  $5E-5$  to  $2.5E-4$  per meter range. Flight C-378 was also at low altitude below clouds. In Fig. 8-8 the low altitude data below 1.2 kilometers for Flight C-378 are within that same range and also in a relatively uniform layer.

*Comparison to Visibility.* The meteorological estimates of horizontal visibility VV have been related to the attenuation coefficient  $\alpha$  by Douglas and Young (1945), and hence may be related to the scattering coefficient in the absence of absorption by

$$VV = \ln 18/\alpha \approx 3/s \quad (8.6)$$

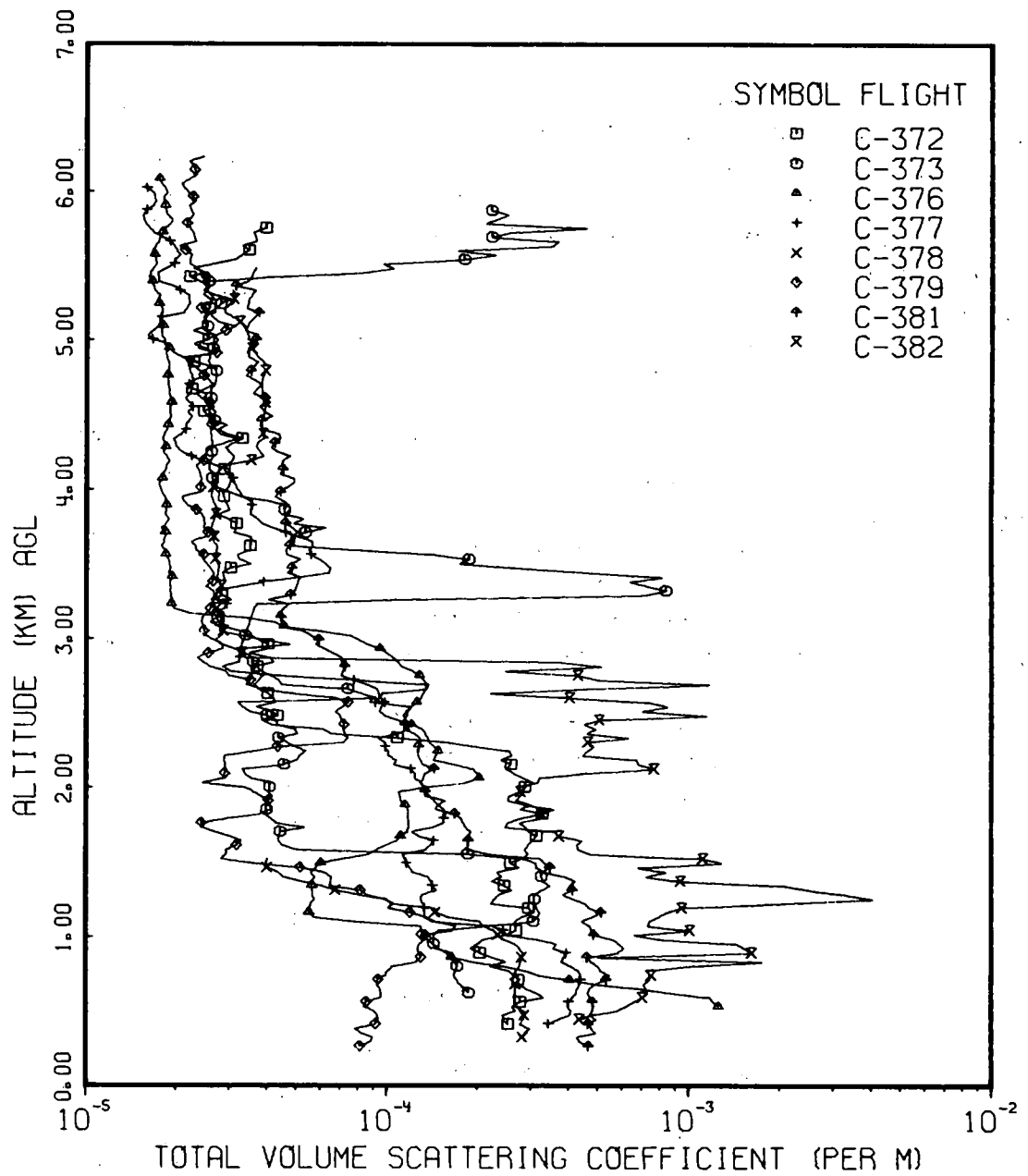

Fig. 8-8. Total Volume Scattering Coefficient for Filter 4 Pseudo-Photopic for Eight OPAQUE I Flights.

An additional discussion of this relationship is presented by Middleton (1952). Visibility values for the low altitude straight and level flight elements based on Eq. 8.6 are given in column 3 of Table 8.4. The visibilities from nearby weather stations as presented in the tables in Section 6.3 for the times just before and after the airborne measurement are given in column 4 of Table 8.4. The airborne visibilities lie close to or within the span of the weather station visibilities except for Flights C-376 and C-379.

In both these cases the measured nephelometer values indicate clearer air at low altitude (550 and 282 meters, respectively) than at ground level at the weather stations.

*Correlation with Relative Humidity.* An attempt was made to correlate the total volume scattering

**Table 8.4**

Low Altitude Visibility Based on Nephelometer Compared to Meteorological Estimates from Weather Stations

Flight No.	Time (GMT)	Visibility (kilometers)		Station
		Airborne Nephelometer	Meteorological Estimate Range	
C-372	1347	15.5	12 – 15	Soesterberg Deelen
			18	
C-373	1254	17.8	12 – 15	Yeovilton Bournemouth-Hurn
			25	
C-376	1052	7.0	2.5 – 3.0	Yeovilton Bournemouth-Hurn
			4.7	
C-377	1108	8.9	8.0	Yeovilton Bournemouth-Hurn
			10 – 14	
C-378	1032	13.1	20	Fehmarnbelt Kegnaes
			10 – 12	
C-379	1143	51.8	20	Fehmarnbelt Kegnaes
			15	
C-381	1103	7.6	8	Meppen Oldenberg Ahlhorn Lingen
			8	
			8	
			18	
C-382	0930	13.5	8	Meppen Oldenburg Ahlhorn Lingen
			11.2	
			11.2	
			5 – 16	

coefficient for filter 4 (pseudo-photopic) with the relative humidity for the SEEKVAL data (Duntley, *et al.* (1975a). These data indicated an approximately linear relationship between the log of the ratio of the total volume scattering coefficient to the Rayleigh total volume scattering coefficient,  $\log [s(z)/_R s(z)]$ , and the relative humidity RH

$$\log [s(z)/_R s(z)] = 1.28 \frac{RH}{100} . \quad (8.7)$$

This was for a flight track in western Washington over forest near an agricultural area, removed from major sources of industrial pollution and auto emissions.

In an attempt to see if this relationship was equally valid for the OPAQUE I data, the nephelometer data from the straight and level flight elements have been put into ratio form and graphed as a function of relative humidity in Fig. 8-9. The superimposed line is for the relationship indicated by Eq. 8.7. Although there is a rough correlation between the ratio of total to Rayleigh volume scattering coefficient and the relative humidity, there is also a great deal of scatter. The relationship for the OPAQUE I data is far less clear cut than it was for the SEEKVAL data.

The correlation for the SEEKVAL data was based upon data taken during the vertical profile elements. It would be useful to see if the rougher correlation for the OPAQUE data which were averaged over a larger time and space interval during the straight and level flight elements remains similar for the shorter time interval vertical profile data. The volume of the vertical profile data and the wish to facilitate the availability of the data herein reported have precluded this quantitative analysis of the OPAQUE I vertical profile data, since the computation and graphing have not yet been automated.

A qualitative though informative comparison of the relative humidity and the total volume scattering coefficient measurements taken during the vertical profile flight elements may be made by examining the graphical displays of relative humidity in Section 6.1 and total volume scattering coefficient in Section 7.3. An illustration of these comparisons was given in Fig. 8-2.

On several flights the comparison of the profile structures is quite close at all altitudes. For example, on flight C-376, there are two primary haze layers, and these show up quite clearly on both profiles, with the changes in each occurring at the same altitudes, and even much of the fine structure showing similarly on both profiles. The only significant difference between the two profiles is the thin layer structure appearing at the higher altitudes on the relative humidity profile which does not appear in the scattering coefficient data.

On many of the flights, the low altitude haze layers show up quite well on both the relative humidity and the scattering coefficient plots, but the profile structures do not compare well at the higher altitudes. For example, on flight C-377, the relative humidity profile indicates a thick layer with very high relative humidities at about 4 to 5 kilometers AGL in addition to the typical low altitude structure. However, the scattering coefficient profile, even though it shows the lower structure clearly, gives little if any indi-

cation of the upper layer. Conversely, on flight C-379, the relative humidity drops to quite low values around 4000 meters AGL, yet the scattering coefficient profile shows no change. In all of these cases the scattering coefficient profiles compare excellently with the profiles of measured path function. These corroborative measurements of path function are not included in this report, but are undergoing further evaluation for presentation at a later date.

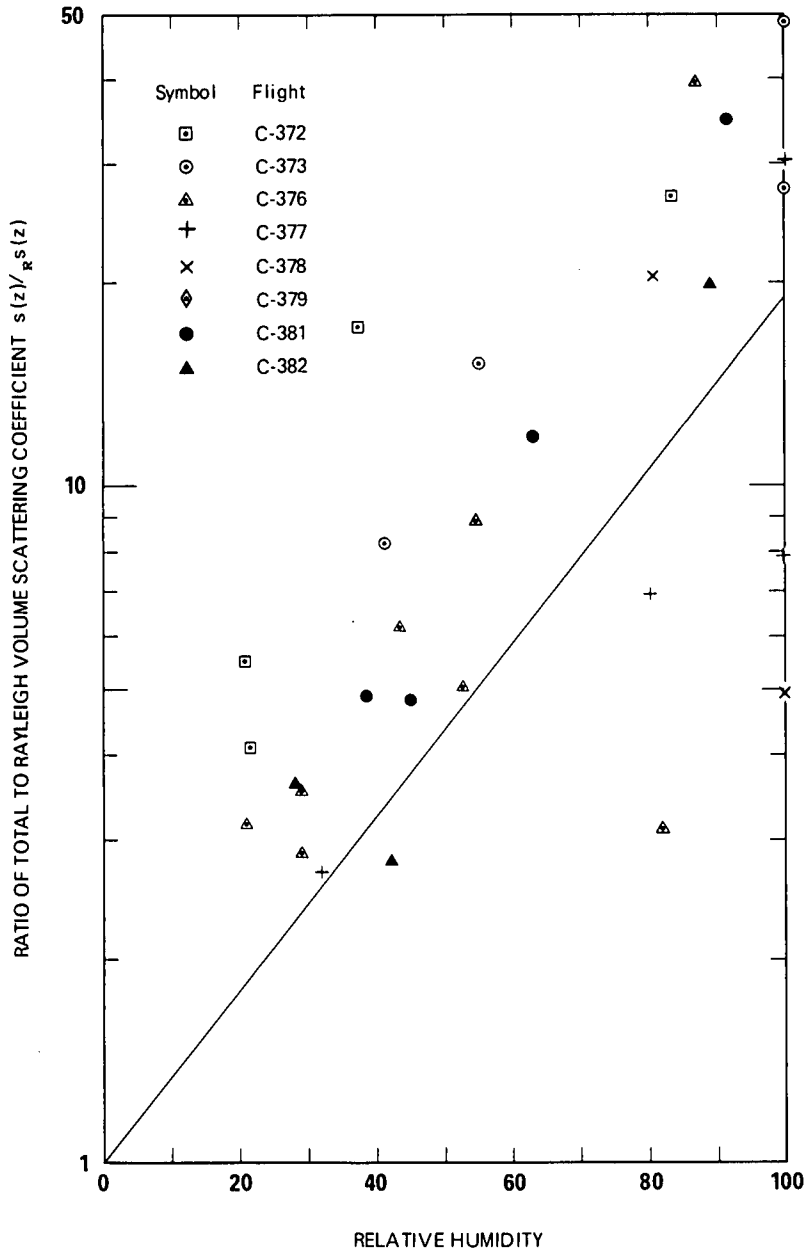

Fig. 8-9. Total Volume Scattering Coefficient for Filter 4 Pseudo-Photopic from Straight and Level Flight Elements as a Function of Relative Humidity.

Flight C-373 is particularly interesting. The onboard meteorologist reported flying through clouds. Both the relative humidity and scattering coefficient measurements swing through large excursions, but the changes do not always come at the same altitudes. It is interesting that in these data the layered structure of the relative humidity and scattering coefficient profiles generally correspond well at the lower altitudes, but often do not at the upper altitudes. Some lag could be attributable to a slowing in the response time of the dewpoint temperature measurements at the colder altitudes, however, comparisons of ascent versus descent data do not indicate discernible differences.

## EQUIVALENT ATTENUATION LENGTH AND BEAM TRANSMITTANCE

Equivalent attenuation length is presented for the path between ground level and altitude. At ground level the equivalent attenuation length is the reciprocal of the total scattering coefficient  $s(z)$ . As altitude increases, the equivalent attenuation length shows the cumulative effect of summing  $s(z)$  from ground level to altitude  $z$ .

The vertical beam transmittance starts at 1.0 at ground level and shows the cumulative effect of the summation of the total scattering coefficient with altitude.

For simultaneous data, or even for sequentially sampled data under reasonably stable and uniform aerosol conditions, the order by filter of the equivalent attenuation length  $\bar{L}$  and the beam transmittance should vary directly as the mean wavelength of the filters, i.e.,  $\bar{L}(\text{Filter 2}) < \bar{L}(4) < \bar{L}(3) < \bar{L}(5)$ . Much of the flight data do not follow this order, primarily because the low altitude total scattering coefficients are not generally in order by filter. The flights with some regularity of attenuation length with filter are Flight C-373 at low altitude, Flight C-377 at all altitudes, Flight C-379 at high altitude, and Flight C-381, except for filters 2 and 4, at midaltitudes.

*Equivalent Attenuation Length and Beam Transmittance Examples.* The equivalent attenuation length table can easily be used in Eq. 2.6 to obtain beam transmittance for various zenith angles for the upward path of sight and for various zenith angles for the downward path of sight.

## EXAMPLES

- A. For an upward path of sight at 60-degree zenith angle, with an object altitude  $z_t$  at 1800 meters, Eq. 2.6 would be written

$$T_{3600}(0,60^\circ) = \exp \left\{ \left[ -1800 / \bar{L}(1800) \right] \sec 60^\circ \right\} .$$

Using the equivalent attenuation length for Flight C-381 filter 4, Eq. 2.6 becomes

$$T_{3600}(0,60^\circ) = \exp \left\{ \left[ -1800\text{m} / 2350\text{m} \right] 2 \right\} = 0.216 .$$

- B. For a downward path of sight at a zenith angle of 135 degrees from a sensor altitude of 900 meters, Eq. 2.6 would become

$$T_{1273}(900, 135^\circ) = \exp \left\{ \left[ -900\text{m} / \bar{L}(900) \right] | \sec 135^\circ | \right\}$$

Again using the values from Flight C-381 filter 4, Eq. 2.6 becomes

$$T_{1273}(900, 135^\circ) = \exp \left\{ \left[ -900\text{m} / 2090\text{m} \right] 1.414 \right\} = 0.544$$

## IRRADIANCE

*Downwelling.* The downwelling irradiance was measured during the straight and level flight elements and during the vertical profiles on each flight. During the straight and level flight elements the intended aircraft flight altitude was 2½ degrees nose high and the dual irradiator was oriented so as to be horizontal during a +2½-degree pitch. The pitch and roll measurements during the straight and level flight elements indicated that average aircraft attitude was such that the dual irradiator was ±1 degree of true horizontal during most of the flights. Downwelling irradiance values for the straight and level flight elements for each flight are presented in columns 7 through 10 in Table 8.5. The corresponding sun zenith angle for each filter and altitude are also presented in columns 3 through 6.

The low-altitude downwelling irradiance values for pseudo-photopic filter 4 for all the OPAQUE I flights are graphed in Fig. 8-10.

The symbols indicate the cloud categories described in Table 8.1. Since the altitudes for the lowest straight and level sequences ranged between 266 and 581 meters above ground level, they can be compared to the ground-level values of Brown (1952). The illuminance values of Brown for unobscured sun, partial cloud, and storm cloud, have been converted to irradiance units and depicted as solid curves in Fig. 8-10.

All of the low altitude OPAQUE I irradiances are less than the clear day irradiances of Brown. The Brown clear day irradiance may be considered appropriate for a space-to-earth transmittance of about 0.7, which is generally used as the average clear day photopic transmittance. The tables in Section 7.3 indicate that six of the flights have vertical 6-kilometer to earth transmittances of 0.11 to 0.50 which are consistent with irradiances less than the Brown clear day standard. These flights are C-372, C-373, C-376, C-377, C-381, and C-382. Flight C-378 did not have measurements above 1800 meters and its 1.8-kilometer to ground transmittance of 0.71 coupled with the presence of clouds above 1.8 kilometers is also consistent with an irradiance less than the clear day standard. Flight C-379, however, is in the no cloud category and has a 6-kilometer to earth transmittance of 0.75. Therefore the C-379 downwelling irradiance was a bit low compared to the Brown clear day standard.

The average pitch of the aircraft during the vertical profile sequences was approximately +8 degrees during ascent and -2 degrees during descent so that the dual irradiator was roughly +5.5 degrees from horizontal during ascent and -4.5 degrees from horizontal during descent. The aircraft heading was generally cross sun to minimize this effect. Generally, however, the orientation of the dual irradiator

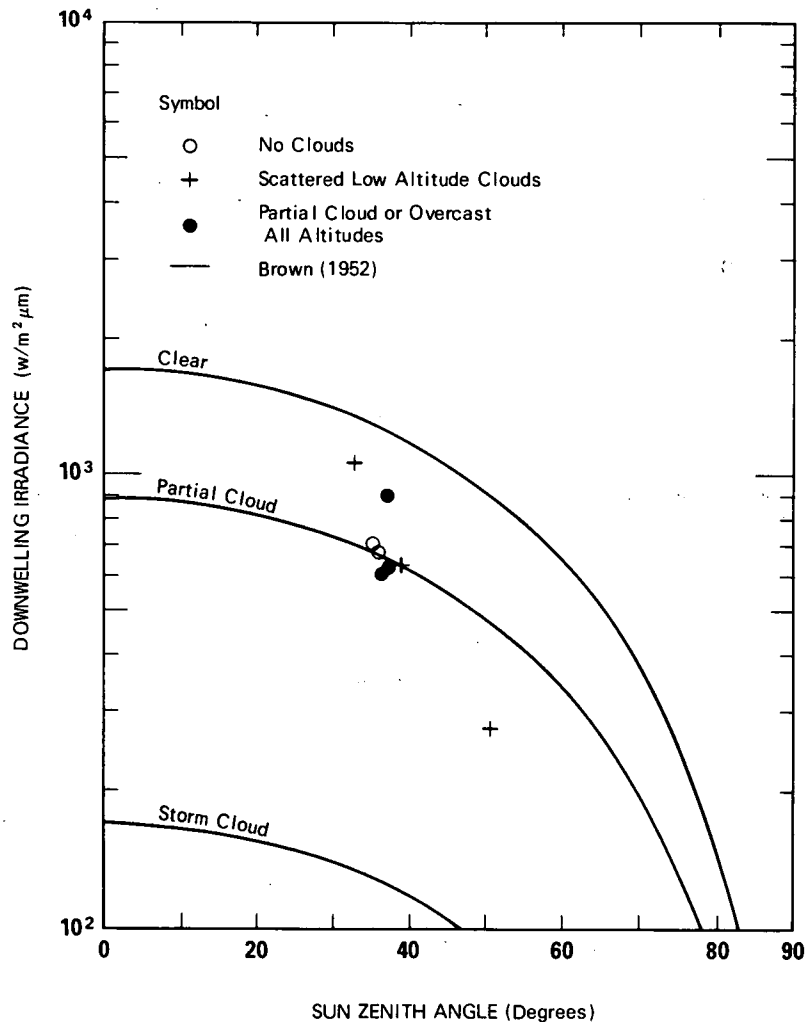

Fig. 8-10. Project OPAQUE I Low Altitude Downwelling Irradiance for Filter 4 Pseudo-Photopic Compared to Brown (1952).

during the vertical profile could not be kept within as close an angular tolerance as during the straight and level flight elements. Therefore it is preferable to use the values from the straight and level sequences in Table 8.5 for the absolute values of downwelling irradiance and to use the vertical profile graphs in Section 7.3 to indicate the variability of downwelling irradiance with space and time during the flight.

The graphs of downwelling irradiance versus altitude in Section 7.3 for the OPAQUE I flights C-376 and C-379 in cloud category 1 are very regular due to the absence of clouds. They show nearly constant irradiances above the level of the haze layers which were measured by the nephelometer. Below the haze, the irradiances in filters 3 and 5 (red and near infrared) decrease steadily with decreasing altitude, while the filter 2 and 4 (blue and pseudo-photopic) show little change. This decrease does not appear to be instrumental, yet its cause has not been determined. The graphs of downwelling irradiance for Flights C-372 and C-377, filters 2 and 3, C-381 and C-382 in category 2, are regular at high altitude

above the clouds and irregular at the lower altitudes among the clouds. The exception is the graph for filter 2, Flight C-372, which is very regular at all altitudes. Apparently the sun was unobscured during

**Table 8.5**

Downwelling Irradiance Measured by the Dual Irradiometer During  
the Straight and Level Flight Elements

Flight No.	Average Altitude (meters)	Sun Zenith Angle (degrees)				Downwelling Irradiance (w/m <sup>2</sup> μm)			
		Filter 2	Filter 4	Filter 3	Filter 5	Filter 2	Filter 4	Filter 3	Filter 5
C-372	5754	47.4	61.6	47.9	62.4	8.91E2	5.73E2	6.89E2	3.99E2
	3000	44.6	57.5	44.9	58.2	9.18E2	6.47E2	7.29E2	4.31E2
	1498	43.6	53.5	43.7	54.2	8.68E2	6.06E2	7.43E2	5.03E2
	279	43.1	50.4	43.1	51.0	8.43E2	2.77E2	7.27E2	3.25E2
C-373	5879	35.9	44.7	36.0	45.3	9.16E2	8.80E2	7.35E2	5.21E2
	3108	35.8	41.4	35.8	42.0	8.48E2	7.92E2	4.61E2	5.57E2
	1568	36.8	38.7	36.6	39.1	5.99E2	7.64E2	7.40E2	5.15E2
	622	38.5	37.0	38.1	37.3	8.45E2	6.32E2	7.54E2	4.01E2
C-376	6058	39.8	33.8	39.3	33.9	1.04E3	1.04E3	8.69E2	7.55E2
	2987	43.2	34.0	42.6	33.9	9.86E2	1.10E3	8.18E2	7.56E2
	1434	46.8	35.1	46.1	34.8	8.84E2	1.04E3	7.19E2	6.92E2
	545	-	36.8	50.0	36.4	-	6.07E2	6.55E2	6.65E2
C-377	6055	38.4	33.5	37.8	33.6	1.10E3	9.78E2	8.59E2	6.91E2
	2982	42.0	33.2	41.3	33.2	1.00E3	-	8.07E2	6.47E2
	1462	45.4	33.8	44.7	33.6	8.43E2	9.19E2	7.35E2	7.24E2
	363	48.9	35.1	48.2	34.8	7.29E2	7.06E2	6.30E2	5.47E2
C-378	1601	38.6	36.5	38.2	36.5	8.14E2	1.03E3	9.00E2	5.28E2
	271	40.1	37.2	39.7	37.0	6.99E2	9.20E2	6.95E2	4.43E2
C-379	5808	35.3	41.2	35.3	41.8	1.12E3	9.70E2	8.85E2	6.49E2
	3167	35.6	38.8	35.5	39.2	1.13E3	9.88E2	9.03E2	6.31E2
	1609	36.5	37.0	36.3	37.3	1.07E3	1.03E3	8.96E2	6.72E2
	293	38.0	35.8	37.7	35.9	1.04E3	6.74E2	8.96E2	6.38E2
C-381	5463	33.5	33.8	41.8	42.4	1.15E3	1.07E3	7.97E2	6.64E2
	3325	32.4	32.6	38.3	39.4	1.17E3	1.08E3	8.63E2	6.77E2
	2107	32.0	32.0	-	-	1.12E3	1.07E3	-	-
	276	32.4	32.3	35.5	35.9	8.31E2	1.05E3	2.75E2	3.11E2
C-382	5444	33.6	33.3	-	-	1.17E3	1.10E3	-	-
	3639	35.4	35.0	-	-	1.16E3	1.08E3	-	-
	335	39.4	38.8	-	-	4.01E2	6.27E2	-	-

the entire vertical profile even though there were clouds at the lower altitudes. The graphs of downwelling irradiance for the flights in category 3, C-373 and C-377, filters 4 and 5, and C-378 are generally irregular at all altitudes which is consistent for generally overcast or clouds at all altitudes.

*Albedo.* The albedo is the ratio of the upwelling to downwelling irradiance. The albedos for the OPAQUE I airborne data are summarized in Table 8.6. The albedos for the flights over land are presented first, and then the flights over water. The low altitude albedos for filters 2, 4, 3, and 5 lie in a reasonable range for cultivated fields with growing crops. Filter 4 values are expected to be slightly higher than the values for filters 2 and 3. The filter 5 values also show the expected high reflectance in the near infrared.

The low altitude albedos over water are also in a reasonable range for the low wind speeds. The over-the-water albedos are relatively neutral spectrally as is reasonable since most of the upwelling irradiance is from reflected sky and sunlight and water reflectance is essentially neutral in this region of the spectrum.

The albedos generally increase as expected with altitude except for filter 5 over the cultivated fields which shows little change with altitude. The large albedos at high altitude for Flight C-382 show the effect of clouds beneath. The filter 5 albedo over cultivated fields is nearly constant with altitude. This may indicate that the inherent terrain radiances are relatively close to the downward path equilibrium radiances for filter 5, thus path length would have little effect on the apparent terrain radiances.

### 8.3 SUMMARY

An accelerated schedule for reporting only selected optical properties has allowed this report to be completed less than a year after the end of the OPAQUE I deployment. This schedule was completed in a relatively short time in spite of the need to devise and implement a method to correct the nephelometer data for the error due to stray light in the system. Now that the system for selected data evaluation has been established, it is expected that ensuing reports of these same selected optical properties should follow swiftly upon completion of each deployment.

The total volume scattering coefficient data were considered of primary interest, hence these have received the closest scrutiny and been reported in the greatest detail. Data on downwelling irradiance and meteorological information were added to make the total scattering coefficient data more useful and to aid in the selection of those flights for which additional optical properties such as path radiance and terrain reflectance might be reported.

The OPAQUE I flights included a wider range of meteorological conditions than previous flights. Some portions of the flights were in clouds, heavy haze, and/or rain. Some of the data also indicate a rapidly changing aerosol so that data taken at the beginning of a two-hour flight do not apply to the same aerosol as the data at the end.

**Table 8.6**

Albedo as Measured by the Dual Irradiometer During the Straight and Level Flight Elements

Flight No.	Average Altitude (meters)	Albedo				Track	Terrain Description
		Filter 2	Filter 4	Filter 3	Filter 5		
C-372	5754	.31	.39	.30	.46	Soesterberg Netherlands	Cultivated fields
	3000	.28	.32	.15	.41		
	1498	.17	.16	.11	.33		
	279	.080	.10	.086	.35		
C-373	5879	.25	.39	.44	.40	Yeovil England	Cultivated fields
	3108	.14	.15	.12	.39		
	1568	.14	.14	.099	.39		
	622	.093	.11	.071	.41		
C-376	6058	.18	.18	.16	.34	Yeovil England	Cultivated fields
	2987	.17	.15	.14	.36		
	1434	.16	.14	.14	.40		
	545	–	.12	.14	.39		
C-377	6055	.19	.18	.15	.46	Yeovil England	Cultivated fields
	2982	.17	–	.12	.50		
	1461	.13	.12	.11	.52		
	363	.070	.095	.077	.49		
C-381	5463	.30	.30	.48	.49	Meppen Germany	Cultivated fields
	3325	.31	.21	.36	.49		
	2107	.21	.31	–	–		
	276	.073	.084	.068	.45		
C-382	5444	.73	.74	–	–	Meppen Germany	Cultivated fields
	3639	.85	.76	–	–		
	335	.069	.083	–	–		
C-378	1601	.14	.14	.088	.10	Rodby Denmark	Water, windspeed 6.2–9.3 mps
	271	.075	.070	.064	.058		
C-379	5808	.14	.14	.091	.11	Rodby Denmark	Water, windspeed 0–6.2 mps
	3167	.11	.12	.064	.11		
	1609	.095	.094	.052	.077		
	293	.059	.054	.039	.040		

## 9. ACKNOWLEDGEMENTS

To be conducted successfully, Project OPAQUE I required the active support of many organizations and individuals. To all of those who so willingly contributed their skills, talents, and inspiration, the authors gratefully acknowledge their debt.

Dr. Robert W. Fenn, Chief, Atmospheric Optics Branch, AFGL  
Scientific Counsel and Technical Monitor

Maj. Robert W. Endlich, USAF, Project Organization and Coordination

Mr. Raymond S. Silva, Operational Services Division, AFGL, for  
continuing logistical support and advice.

4950th Test Wing (DOC & MAOP) Wright-Patterson Air Force Base, for all aircrew assignments

Capt. Norman A. Rice, Aircraft Commander

Capt. James E. Rodgers, Pilot

SSgt. Ronald Stewart, Flight Engineer

Sgt. Gary Faubus, Scanner

Sgt. Anthony Martin, Crew Chief

TSgt. Henry Brown, Maintenance Specialist

TSgt. Donald Johnson, Maintenance Specialist

SSgt. Frank Duckworth, Maintenance Specialist

Sgt. Stevan Wood, Maintenance Specialist

Sgt. Daniel Aguilar, Maintenance Specialist

Sgt. John Appleby, Maintenance Specialist

Visibility Laboratory, Technical Field Team

Mr. Nils R. Persson, Jr., Ground Station Crew

Mr. George F. Simas, Ground Station Crew

Mr. Robert L. Stapleford, Technical Flight Crew

Visibility Laboratory, Data Processing and Analysis Team

Mr. Nils R. Persson, Jr.

Ms. Janet E. Shields

Ms. Catharine F. Edgerton

Mr. Steven J. Bettinger

**Visibility Laboratory, Editorial and Reproduction Team**

**Mr. John C. Brown**

**Ms. Arlene C. Streed**

**Mr. James Rodriguez**

**Ms. Alicia G. Enriquez**

**Physics Laboratory of the National Defense Research Organization (TNO)**

**The Hague, Netherlands**

**Ir T. Bakker**

**Ir J. Van Schie**

**Ir J. Winters**

**Erprobungsstelle 91 der Bundes Wehr**

**Meppen, Germany**

**Mr. Lichtenberg**

**Mr. Husemann**

**Institute for Physics of the Atmosphere**

**Oberpfaffenhofen, Germany**

**Dr. Von Redwitz**

**Dr. Volkmar Wilkins**

## 10. REFERENCES

Barteneva, O. D. (1960), "Scattering Functions of Light in the Atmospheric Boundary Layer," Bull. Acad. Sci. U.S.S.R., Geophysics Series, 1237 – 1244.

Beutell, R. G. and A. W. Brewer (1949), "Instruments for the Measurement of the Visual Range," J. Sci. Instr. 26, 357 – 359.

Boileau, A. R. (1964), "VI. Atmospheric Properties," Appl. Opt. 3, 570 – 581.

Brown, D. R. E. (1952), Natural Illumination Charts, Report 374-1, Project Ns-714-100, Department of the Navy, Bureau of Ships, Washington, D. C.

Douglas, C. A. and L. L. Young (1945), "Development of Transmissometer for Determining Visual Range," U. S. Department of Commerce, Civil Aeronautics Administration, Washington, D. C., Technical Development Report No. 47.

Duntley, S. Q., A. R. Boileau, and R. W. Preisendorfer (1957), "Image Transmission by the Troposphere I," J. Opt. Soc. Am. 47, 499 – 506.

Duntley, S. Q., R. W. Johnson, and J. I. Gordon (1964), "Ground-Based Measurements of Earth-to-Space Beam Transmittance, Path Radiance, and Contrast Transmittance," University of California, San Diego, Scripps Institution of Oceanography, Visibility Laboratory, Tech. Doc. Report No. AL-TDR-64-245.

Duntley, S. Q. (1969), "Directional Reflectance of Atmospheric Paths of Sight," Duntley Rep. No. 69-1.

Duntley, S. Q., R. W. Johnson, J. I. Gordon, and A. R. Boileau (1970a), "Airborne Measurements of Optical Atmospheric Properties at Night," University of California, San Diego, Scripps Institution of Oceanography, Visibility Laboratory, SIO Ref. 70-7, AFCRL-70-0137.

Duntley, S. Q., C. F. Edgerton, and T. J. Petzold (1970b), "Atmospheric Limitations on Remote Sensing of Sea Surface Roughness by Means of Reflected Daylight," University of California at San Diego, Scripps Institution of Oceanography, Visibility Laboratory, SIO Ref. 70-27.

Duntley, S. Q., R. W. Johnson, and J. I. Gordon (1972a), "Airborne Measurements of Optical Atmospheric Properties in Southern Germany," University of California, San Diego, Scripps Institution of Oceanography, Visibility Laboratory, SIO Ref. 72-64, AFCRL-72-0255.

- Duntley, S. Q., R. W. Johnson, and J. I. Gordon (1972b), "Airborne and Ground-Based Measurements of Optical Atmospheric Properties in Central New Mexico," University of California, San Diego, Scripps Institution of Oceanography, Visibility Laboratory, SIO Ref. 72-71, AFCRL-72-0461.
- Duntley, S. Q., R. W. Johnson, and J. I. Gordon (1972c), "Airborne Measurements of Optical Atmospheric Properties, Summary and Review," University of California, San Diego, Scripps Institution of Oceanography, Visibility Laboratory, SIO Ref. 72-82, AFCRL-72-0593.
- Duntley, S. Q., R. W. Johnson, and J. I. Gordon (1973), "Airborne Measurements of Optical Atmospheric Properties in Southern Illinois," University of California, San Diego, Scripps Institution of Oceanography, Visibility Laboratory, SIO Ref. 73-24, AFCRL-TR-73-0422.
- Duntley, S. Q., R. W. Johnson, and J. I. Gordon (1974), "Airborne and Ground-Based Measurements of Atmospheric Properties in Southern Illinois," University of California, San Diego, Scripps Institution of Oceanography, Visibility Laboratory, SIO Ref. 74-25, AFCRL-TR-74-0298.
- Duntley, S. Q., R. W. Johnson, and J. I. Gordon (1975a), "Airborne Measurements of Optical Atmospheric Properties in Western Washington," University of California, San Diego, Scripps Institution of Oceanography, Visibility Laboratory, SIO Ref. 75-24, AFCRL-TR-75-0414.
- Duntley, S. Q., R. W. Johnson, and J. I. Gordon (1975b), "Airborne Measurements of Optical Atmospheric Properties, Summary and Review II," University of California, San Diego, Scripps Institution of Oceanography, Visibility Laboratory, SIO Ref. 75-26, AFCRL-TR-75-0457.
- Duntley, S. Q., R. W. Johnson, and J. I. Gordon (1976), "Airborne Measurements of Optical Atmospheric Properties in Northern Germany," University of California, San Diego, Scripps Institution of Oceanography, Visibility Laboratory, SIO Ref. 76-17, AFGL-TR-76-0188.
- Edgerton, C. F. (1967), "Relationship Between Meteorological Conditions and Optical Properties of the Atmosphere," University of California, San Diego, Scripps Institution of Oceanography, Visibility Laboratory, SIO Ref. 67-27.
- Gordon, J. I., J. L. Harris, and S. Q. Duntley (1963), "Earth-to-Space Contrast Transmittance Measurements from Ground Stations," University of California, San Diego, Scripps Institution of Oceanography, Visibility Laboratory, SIO Ref. 63-2.
- Gordon, J. I. (1969), "Model for a Clear Atmosphere," *J. Opt. Soc. Am.* **59**, 14–18.
- Gordon, J. I., J. L. Harris, Sr., and S. Q. Duntley (1973), "Measuring Earth-to-Space Contrast Transmittance from Ground Stations," *Appl. Opt.* **12**, 1317–1323.
- Middleton, W.E.K. (1952), *Vision Through the Atmosphere*, University of Toronto Press, Chap. 10.
- Smithsonian Meteorological Tables* (1951), Smithsonian Institution, Washington, D. C.
- USNAF TP-133, U.S. Naval Avionics Facility (1962), "Handbook, Operation and Service Instructions Aerograph Sets AN/AMQ-17 and AN/AMQ-18," Indianapolis 18, Indiana.
- U.S. Standard Atmosphere (1962), U.S. Government Printing Office, Washington, D.C. 20402.
- U.S. Standard Atmosphere Supplements (1966), U.S. Government Printing Office, Washington, D.C. 20402.