

SECURITY CLASSIFICATION OF THIS PAGE (When Data Entered)

REPORT DOCUMENTATION PAGE		READ INSTRUCTIONS BEFORE COMPLETING FORM								
1 REPORT NUMBER AFGL-TR-77-0239	2 GOVT ACCESSION NO	3 RECIPIENT'S CATALOG NUMBER								
4 TITLE (and Subtitle) AIRBORNE MEASUREMENTS OF ATMOSPHERIC VOLUME SCATTERING COEFFICIENTS IN NORTHERN EUROPE, FALL 1976		5 TYPE OF REPORT & PERIOD COVERED Scientific - Interim Scientific Report No 8								
		6 PERFORMING ORG REPORT NUMBER SIO Ref. 78-3								
7 AUTHOR(s) Seibert Q Duntley Richard W Johnson Jacqueline I Gordon		8 CONTRACT OR GRANT NUMBER(s) F19628-76-C-0004								
9 PERFORMING ORGANIZATION NAME AND ADDRESS University of California, San Diego Visibility Laboratory La Jolla, California 92093		10 PROGRAM ELEMENT PROJECT TASK AREA & WORK UNIT NUMBERS DoD Element 62101F Project, Task, Work Unit No 7621 11 01								
11 CONTROLLING OFFICE NAME AND ADDRESS Air Force Geophysics Laboratory Hanscom AFB, Massachusetts 01731 Contract Monitor Major Cress/OPA		12 REPORT DATE January 1978								
		13 NUMBER OF PAGES 184								
14 MONITORING AGENCY NAME & ADDRESS (if different from Controlling Office)		15 SECURITY CLASS (of this report) UNCLASSIFIED								
		15a DECLASSIFICATION/DOWNGRADING SCHEDULE								
16 DISTRIBUTION STATEMENT (of this Report) Approved for public release, distribution unlimited										
17 DISTRIBUTION STATEMENT (of the abstract entered in Block 20, if different from Report)										
18 SUPPLEMENTARY NOTES										
19 KEY WORDS (Continue on reverse side if necessary and identify by block number)										
<table border="0"> <tr> <td>Albedos</td> <td>Natural Daytime Irradiance</td> </tr> <tr> <td>Atmospheric Optical Properties</td> <td>Temperature Profile</td> </tr> <tr> <td>Atmospheric Scattering Coefficient</td> <td>Relative Humidity Profile</td> </tr> <tr> <td>Atmospheric Beam Transmittance</td> <td></td> </tr> </table>			Albedos	Natural Daytime Irradiance	Atmospheric Optical Properties	Temperature Profile	Atmospheric Scattering Coefficient	Relative Humidity Profile	Atmospheric Beam Transmittance	
Albedos	Natural Daytime Irradiance									
Atmospheric Optical Properties	Temperature Profile									
Atmospheric Scattering Coefficient	Relative Humidity Profile									
Atmospheric Beam Transmittance										
20 ABSTRACT (Continue on reverse side if necessary and identify by block number)										
<p>This report presents daytime atmospheric optical data collected chiefly with airborne instruments during a field expedition to northern Europe in the fall of 1976. Results from 12 flights are presented. The data include the natural irradiance upon horizontal plane surfaces, total volume scattering coefficients, atmospheric beam transmittances. Data for daytime conditions ranging from scattered clouds to completely overcast are presented. Data were measured in four spectral regions, as follows: Three narrow band optical filters with mean wavelengths of 478, 664, and 765 nanometers, and one broad band sensitivity representing a pseudo-photopic response with a mean wavelength of 557 nanometers.</p>										

20. ABSTRACT continued:

Selected meteorological properties, measured concurrently with the radiometric data are also included.

AIRBORNE MEASUREMENTS OF ATMOSPHERIC VOLUME SCATTERING
COEFFICIENTS IN NORTHERN EUROPE, FALL 1976

Seibert Q. Duntley, Richard W. Johnson, and Jacqueline I. Gordon

Visibility Laboratory
University of California, San Diego
Scripps Institution of Oceanography
La Jolla, California 92093

Approved:

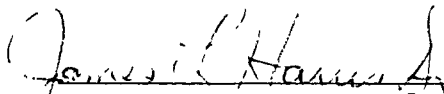

James L. Harris, Sr., Director
Visibility Laboratory

Approved:

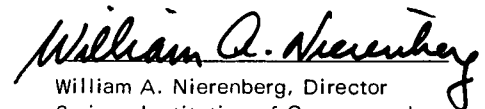

William A. Nierenberg, Director
Scripps Institution of Oceanography

CONTRACT NO. F19628-76-C-0004

Project No. 7621

Task No. 7621-11

Work Unit No. 7621-11-01

Scientific Report No. 8

January 1978

Contract Monitor

Major Ted S. Cress, Atmospheric Optics Branch, Optical Physics Division

Approved for public release; distribution unlimited.

Prepared for
AIR FORCE GEOPHYSICS LABORATORY
AIR FORCE SYSTEMS COMMAND
UNITED STATES AIR FORCE
HANSCOM AFB, MASSACHUSETTS 01731

SUMMARY

This report, which describes portions of the Visibility Laboratory's Project OPAQUE II* effort, was prepared under AFGL Contract F19628-76-C-0004. The principal project task was to take daytime atmospheric optical measurements in northern Europe and, from these measurements, to determine optical properties for various upward- and downward-inclined paths of sight. These properties include the natural irradiance upon horizontal plane surfaces, scalar irradiances, total volume scattering coefficients, atmospheric beam transmittances, path radiances, directional path reflectances, and directional sky and terrain reflectances. This report does not contain all of these optical properties, but in an effort to accelerate the availability of selected values, we have restricted the data to total volume scattering coefficients, atmospheric beam transmittances, and natural irradiances upon horizontal plane surfaces. The data base for the derivation of the additional, more directional optical properties is available on tape and can be exploited upon demand. Selected meteorological properties measured concurrently with the radiometric data are also included.

The OPAQUE II field trip was made to northern Europe during October, November, and December 1976. Data were recorded in three separate geographical regions – namely, off the southern coast of Denmark, over northern Germany, and over western France. The daytime flight conditions for the 12 flights reported herein ranged from scattered clouds at low altitude and clear at high altitude to fully overcast.

The airborne radiometric instrumentation, developed at the Visibility Laboratory and mounted in Air Force C-130A Aircraft No. 50022, consisted of a total scattering meter (or integrating nephelometer) for determining the total volume scattering coefficient, two sky scanning radiometers for measuring upper and lower hemisphere (sky and terrain) radiances, a dual irradiator for measuring alternately the downwelling and upwelling irradiances, an equilibrium radiance telephotometer, and a variable direction path function meter. The meteorological instrumentation included an absolute pressure transducer, a dewpoint hygrometer, and an AN/AMQ-17 aerograph for measuring ambient temperature and pressure.

* The project title OPAQUE II has been assigned to this activity by the Air Force Geophysics Laboratory as a nickname for procedural identification only. It is not necessarily utilized or recognized by agencies or organizations outside of the participating USAF organizations and the Visibility Laboratory. The relationship between this activity and other similar activities conducted by the Visibility Laboratory is well-illustrated in AFCRL-TR-75-0457, Duntley, *et al.* (1975b).

A Visibility Laboratory ground-based data station equipped with a contrast reduction meter for determining earth-to-space beam transmittance was located near the flight track during the flights in Germany and France. It was not utilized during the flights in Denmark.

Each optical instrument was fitted with five optical filters causing it to measure at three narrow wavelength bands of the spectrum and two broad pass bands. The measurements were made using three narrow band filters at mean wavelengths of 478, 664, and 765 nanometers and a pseudo-photopic filter with a mean wavelength of 557 nanometers.

All primary data were recorded on magnetic tapes which were returned to the Visibility Laboratory for processing at the computer facilities of the University of California, San Diego.

TABLE OF CONTENTS

SUMMARY	v
LIST OF ILLUSTRATIONS	ix
RELATED CONTRACTS AND PUBLICATIONS	xi
GLOSSARY AND NOTATION	xiii
1. INTRODUCTION	1-1
2. THEORY AND COMPUTATIONS	2-1
3. INSTRUMENTATION	3-1
3.1 Radiometric Systems	3-1
3.2 Meteorological Systems	3-4
3.3 Control and Communication Systems	3-5
3.4 Photographic Systems	3-5
3.5 Radiometric Calibration Procedures	3-5
3.6 Standard Response Characteristics for Broad Band Sensors	3-7
4. DATA COLLECTION METHODS	4-1
4.1 Airborne System	4-1
4.2 Ground-Based System	4-4
5. DATA PROCESSING	5-1
5.1 Airborne Data	5-1
5.2 Ground-Based Data	5-4
5.3 Calibration Data	5-4
5.4 Data Tapes	5-4
6. WEATHER SUMMARY	6-1
6.1 Introduction and Graphics	6-1
6.2 Synoptic Conditions	6-12
6.3 Tabular Summary and Glossary	6-14

7.	DATA PRESENTATION	7-1
7.1	Airborne Data and Flight Summary	7-1
7.2	Description of Airborne Data Tables and Graphs	7-8
7.3	Presentation of Airborne Data	7-10
8.	DATA INTERPRETATION AND EVALUATION	8-1
8.1	Meteorological Data	8-1
8.2	Airborne Radiometric Data	8-5
8.3	Summary	8-31
9.	ACKNOWLEDGEMENTS	9-1
10.	REFERENCES	10-1

LIST OF ILLUSTRATIONS

Figure		Page
1-1a	Typical OPAQUE II Flight Tracks	1-2
1-1b	Typical OPAQUE II Data Sites, Detail Maps. Latitude and Longitude References are to Flight Track Center Point	1-2
1-1c	Typical OPAQUE II Data Sites, Detail Maps. Latitude and Longitude References are to Flight Track Center Point	1-3
1-1d	Typical OPAQUE II Data Sites, Detail Maps. Latitude and Longitude References are to Flight Track Center Point	1-3
1-2	Standard Spectral Responses – Project OPAQUE II	1-4
2-1	Path Length Geometry for Steeply Inclined Paths of Sight	2-3
3-1	C-130 Airborne Instrument System	3-2
3-2	Ground-Based Instrument System	3-2
3-3	Artist's Rendition of Modified Integrating Nephelometer	3-3
3-4	Typical Absolute Calibration Form	3-6
4-1	Typical Visibility Laboratory Flight Profile	4-2
5-1	Atmospheric Visibility Program Airborne Data Processing Schedule	5-2
5-2	Atmospheric Visibility Program Ground Data Processing Schedule	5-3
6-1	Synoptic Charts of European Area During Project OPAQUE II	6-2, 6-3, 6-4
6-2	Temperature Versus Altitude for Twelve Project OPAQUE II Flights	6-5, 6-6, 6-7
6-3	Relative Humidity Versus Altitude for Eleven Project OPAQUE II Flights	6-8, 6-9, 6-10
7-1	Typical Sky and Terrain Photographs for Flights C-391 and C-392	7-6
7-2	Typical Sky and Terrain Photographs for Flights C-397 and C-401	7-7
8-1	Temperature for OPAQUE II Flights From 26 October to 23 November 1976, Latitudes 53°N to 54.68°N Compared to Temperature From U.S. Standard Atmosphere Supplements (1966).	8-3

8-2	Temperature for OPAQUE II Flights From 2 December to 6 December 1976, Latitude 48.02°N Compared to Temperature from U.S. Standard Atmosphere Supplements (1966).	8-4
8-3	Measured Proportional Volume Scattering Function Versus the Ratio of Total to Rayleigh Volume Scattering Coefficient for OPAQUE II Pseudo-Photopic Filter 4 Mean Wavelength 557 Nanometers	8-6
8-4	Total Volume Scattering Coefficient Versus Volume Scattering Function at 30 Degrees for OPAQUE II Filter 4 Pseudo-Photopic Mean Wavelength 557 Nanometers, $C = 2.37 \times 10^{-5}$	8-7
8-5	Total Volume Scattering Coefficient for Filter 4 Pseudo-Photopic for Seven OPAQUE II Flights, 25 October Through 23 November 1976	8-9
8-6	Total Volume Scattering Coefficient for Filter 4 Pseudo-Photopic for Five OPAQUE II Flights, 2 December Through 6 December 1976	8-10
8-7	Low Altitude Total Volume Scattering Coefficients for Type I and Type II Profiles	8-12
8-8	Low Altitude Total Volume Scattering Coefficients for Type II and Type III Profiles	8-13
8-9	Low Altitude Total Volume Scattering Coefficients for Type III and Type IV Profiles	8-14
8-10	Total Volume Scattering Coefficient for Filter 4 Pseudo-Photopic From Straight and Level Flight Elements as a Function of Relative Humidity for OPAQUE II	8-21
8-11	Comparison of the Photopic Scattering Coefficient and Relative Humidity Profiles as Measured During Flights C-391 and C-395	8-22
8-12	Project OPAQUE II Low Altitude Downwelling Irradiance for Filter 4 Pseudo-Photopic Compared to Brown (1952)	8-25
8-13	Downwelling Irradiance for Filter 4 Pseudo-Photopic for Seven OPAQUE II Flights, 25 October Through 23 November 1976	8-27
8-14	Downwelling Irradiance for Filter 4 Pseudo-Photopic for Five OPAQUE II Flights, 2 December Through 6 December 1976	8-28

RELATED CONTRACTS AND PUBLICATIONS

Related Contracts: None

Publications:

Duntley, S. Q., R. W. Johnson, and J. I. Gordon, "Airborne Measurements of Optical Atmospheric Properties in Southern Germany," AFCRL-72-0255, SIO Ref. 72-64 (July 1972).

Duntley, S. Q., R. W. Johnson, and J. I. Gordon, "Airborne and Ground-Based Measurements of Optical Atmospheric Properties in Central New Mexico," AFCRL-72-0461, SIO Ref. 72-71 (September 1972).

Duntley, S. Q., R. W. Johnson, and J. I. Gordon, "Airborne Measurements of Optical Atmospheric Properties, Summary and Review," AFCRL-72-0593, SIO Ref. 72-82 (November 1972).

Duntley, S. Q., R. W. Johnson, and J. I. Gordon, "Airborne Measurements of Optical Atmospheric Properties in Southern Illinois," AFCRL-TR-73-0422, SIO Ref. 73-24 (July 1973).

Duntley, S. Q., R. W. Johnson, and J. I. Gordon, "Airborne and Ground-Based Measurements of Optical Atmospheric Properties in Southern Illinois," AFCRL-TR-74-0298, SIO Ref. 74-25 (June 1974).

Duntley, S. Q., R. W. Johnson, and J. I. Gordon, "Airborne Measurements of Optical Atmospheric Properties in Western Washington," AFCRL-TR-75-0414, SIO Ref. 75-24 (September 1975).

Duntley, S. Q., R. W. Johnson, and J. I. Gordon, "Airborne Measurements of Optical Atmospheric Properties, Summary and Review II," AFCRL-TR-75-0457, SIO Ref. 75-26 (September 1975).

Duntley, S. Q., R. W. Johnson, and J. I. Gordon, "Airborne Measurements of Optical Atmospheric Properties in Northern Germany," AFGL-TR-76-0188, SIO Ref. 76-17 (September 1976).

Duntley, S. Q., R. W. Johnson, and J. I. Gordon, "Airborne Measurements of Atmospheric Volume Scattering Coefficients in Northern Europe, Spring 1976," AFGL-TR-77-0078, SIO Ref. 77-8 (March 1977).

Gordon, J. I., J. L. Harris, Sr., and S. Q. Duntley, "Measuring Earth-to-Space Contrast Transmittance from Ground Stations," *Appl. Opt.* **12**, 1317-1324 (1973).

Gordon, J. I., C. F. Edgerton, and S. Q. Duntley, "Signal-Light Nomogram," *J. Opt. Soc. Am.* **65**, 111-118 (1975).

GLOSSARY AND NOTATION

The notation used in reports and journal articles produced by the Visibility Laboratory staff follows, in general, the rules set forth in pages 499 and 500, Duntley *et al.* (1957). These rules are:

Each optical property is indicated by a basic (parent) symbol.

A presubscript may be used with the parent symbol as an identifier, e.g., b indicates background while t denotes an object.

A postsubscript may be used to indicate the length of a path of sight, e.g., r denotes an *apparent* property as measured at the end of a path of sight of length r , while o denotes an *inherent* property based upon the hypothetical concept of a photometer located at zero distance from an object.

A postsuperscript*, or a postsubscript*, is employed as a mnemonic symbol signifying that the radiometric quantity has been generated by the scattering of ambient light reaching the path from all directions.

The parenthetical attachments to the parent symbol denote altitude and direction. The letter z indicates altitude in general; z_t is used to specify the altitude of an object. The direction of a path of sight is specified by the zenith angle θ and the azimuth ϕ . In the case of irradiances, the downwelling irradiance is designated by d , the upwelling by u .

The glossary for meteorological symbols is presented in Section 6.

$A(z)$	Albedo at altitude z , defined by the equation $A(z) \equiv H(z,u)/H(z,d)$.
AGL	Above ground level.
e_v	Saturated vapor pressure at dewpoint or frostpoint temperature.
e_s	Saturated vapor pressure at ambient temperature.

$H(z,d)$ Irradiance produced by downwelling flux as determined on a horizontal flat plate at altitude z . In this report d is used in place of the minus sign in the notation $H(z,-)$ which appears in Duntley (1969). This property may be defined by the equation

$$H(z,d) \equiv \int_{2\pi} N(z,\theta',\phi') \cos\theta' d\Omega .$$

$H(z,u)$ Irradiance produced by upwelling flux as determined on a horizontal flat plate at altitude z . Here u is substituted for the plus sign formerly used in the notation $H(z,+)$.

$L(z)$ Attenuation length at altitude z . This property is the reciprocal of the attenuation coefficient, that is,

$$L(z) \equiv \alpha(z)^{-1} .$$

$\bar{L}(z)$ Equivalent attenuation length is defined as

$$\bar{L}(z) = \frac{-z}{\ln T_z(0,0)} .$$

$N(z,\theta,\phi)$ Radiance as determined from altitude z in the direction specified by zenith angle θ and azimuth ϕ .

RH Relative humidity in percent $RH = (e_v/e_s) 100$.

$R/M(0)$ Universal gas constant.

$\overline{S_\lambda T_\lambda}$ Standardized relative spectral response of filter/cathode combination where S_λ is spectral sensitivity of the multiplier phototube cathode and T_λ is spectral transmittance of optical filter.

$s(z)$ Total volume scattering coefficient as determined at altitude z . This property may be defined by the equation

$$s(z) \equiv \int_{4\pi} \sigma(z,\beta) d\Omega .$$

In the absence of atmospheric absorption, the total volume scattering coefficient is numerically equal to the attenuation coefficient.

$R_s(z)$ Total volume scattering coefficient for Rayleigh scattering at altitude z .

$T_r(z, \theta)$	Beam transmittance as determined at altitude z for a path of sight of length r at zenith angle θ . This property is independent of azimuth in atmospheres having horizontal uniformity. It is always the same for the designated path of sight or its reciprocal.
VV	Visibility as estimated by the meteorologists $VV \approx 3/s(z)$.
z	Altitude, usually used as above ground level.
z_i	Altitude of an object.
$\alpha(z)$	Volume attenuation coefficient as determined at altitude z . In the absence of atmospheric absorption, the attenuation coefficient is numerically equal to the volume scattering coefficient.
β	Symbol for scattering angle of flux from a light source. It is equal to the angle between the line from the source to the observer and the path of sight.
Δ	Symbol to indicate incremental quantity and used with r and z to indicate small, discrete increments in path length r and altitude z .
δ_λ	Response area is defined as $\delta_\lambda = \overline{(S_\lambda T_\lambda)} \Delta \lambda$.
θ	Symbol for zenith angle. This symbol is usually used as one of two coordinates to specify the direction of a path of sight.
θ'	Symbol for zenith angle usually used as one of two coordinates to specify the direction of a discrete portion of the sky.
λ	Symbol for wavelength.
$\bar{\lambda}$	Mean wavelength is defined as $\bar{\lambda} \equiv \Sigma \lambda (\overline{S_\lambda T_\lambda}) \Delta \lambda / \delta_\lambda$.
$\rho(z)$	Density at altitude z .
σ	Symbol for volume scattering function. Parenthetical symbols may be added; for example, β may be used to designate the scattering angle from a source. In Gordon (1969) the parenthetical symbols are z and β for altitude and scattering angle.
$\sigma(z, \beta) / s(z)$	Proportional directional volume scattering function. This may be defined by the equation

$$\int_{4\pi} [\sigma(z, \beta) / s(z)] d\Omega \equiv 1 .$$

ϕ Symbol for azimuth. The azimuth is the angle in the horizontal plane of the observer between a fixed point and the path of sight. The fixed point may be, for example, true north, the bearing of the sun, or the bearing of the moon. This symbol is usually used as one of two coordinates to specify the direction of a path of sight.

ϕ' This symbol for azimuth is usually used as one of two coordinates to specify the direction of a discrete portion of the sky.

Ω Symbol for solid angle. For a hemisphere

$$\Omega = 2\pi \text{ steradians;}$$

for a sphere $\Omega = 4\pi \text{ steradians}$

1. INTRODUCTION

The field measurement program described in this report was organized under the project title OPAQUE II (Optical Atmospheric Quantities in Europe). It was conducted during October, November, and December 1976, to obtain data for case studies of the fall season atmospheric optical properties over northern Europe.

The OPAQUE II deployment was the second in a series that is planned to provide atmospheric optical data in several regions of northern Europe. These deployments are organized as a cooperative but independent effort associated with the NATO Research Study Group 8 of Panel IV, AC243. The OPAQUE II deployment plan was specified in Air Force Geophysics Laboratory OPLAN for OPAQUE II, dated 10 April 1977.

The Visibility Laboratory maintains a continuing program of improved techniques for predicting, by calculation from physical data, the probabilities that any object can be visually detected and recognized. The program is multifaceted in that it involves the development of techniques and expertise in several different technical areas, each related to the visual detection and recognition task. Several of the major areas are, for example, measurement and analysis of typical terrain characteristics and scene reflectances, studies in the restoration of atmospherically distorted images, measurement and analysis of the optical properties of the atmosphere, and studies into the perceptual capabilities of the human visual system and its electro-optical counterparts. The joint application of the techniques perfected in each of these specialty areas results in the determination of detection probabilities. Inclusion of allowances for *a priori* information and reasoning processes of the brain enable the probabilities of recognition, classification, and identification of real-world objects to be predicted.

The instrumental and computational organization for implementing the continuing improvement of those techniques related to the documentation of optical atmospheric properties is documented in several preceding reports. The most recent of these reports is AFGL-TR-77-0078, Duntley, *et al.* (1977).

This report, Scientific Report No. 8, has been prepared under Contract No. F19628-76-C-0004. It contains measured profiles of atmospheric volume scattering coefficient and downwelling irradiances between ground level and altitudes up to 6 kilometers. Computed values for vertical atmospheric beam transmittance and equivalent attenuation length are also presented for the same altitude interval. The measurements were made along the flight tracks illustrated in Figs. 1-1a, 1-1b, 1-1c, and 1-1d. Selected meteorological properties measured concurrently with the radiometric data are also included.

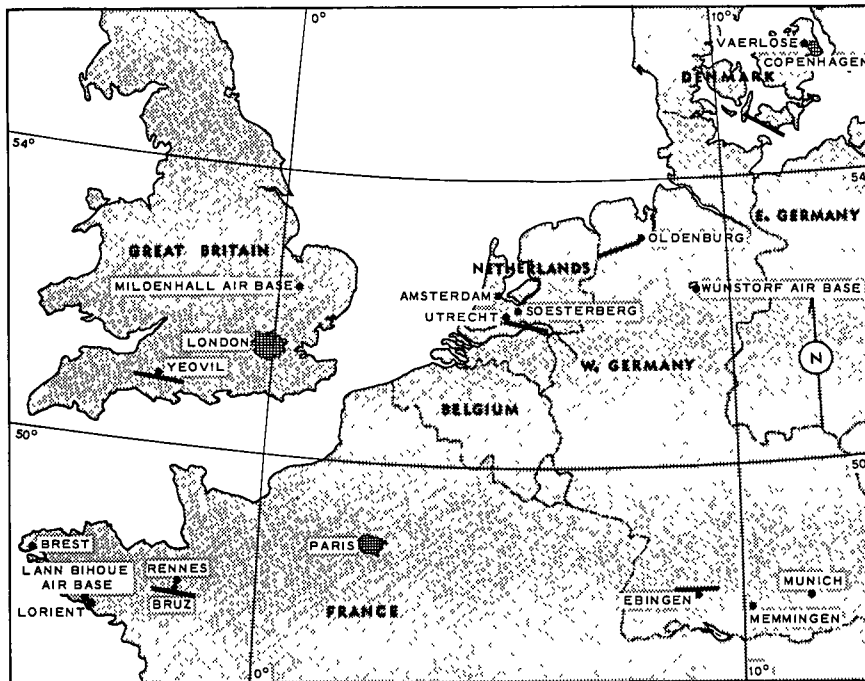

Fig. 1-1a. Typical OPAQUE II Flight Tracks.

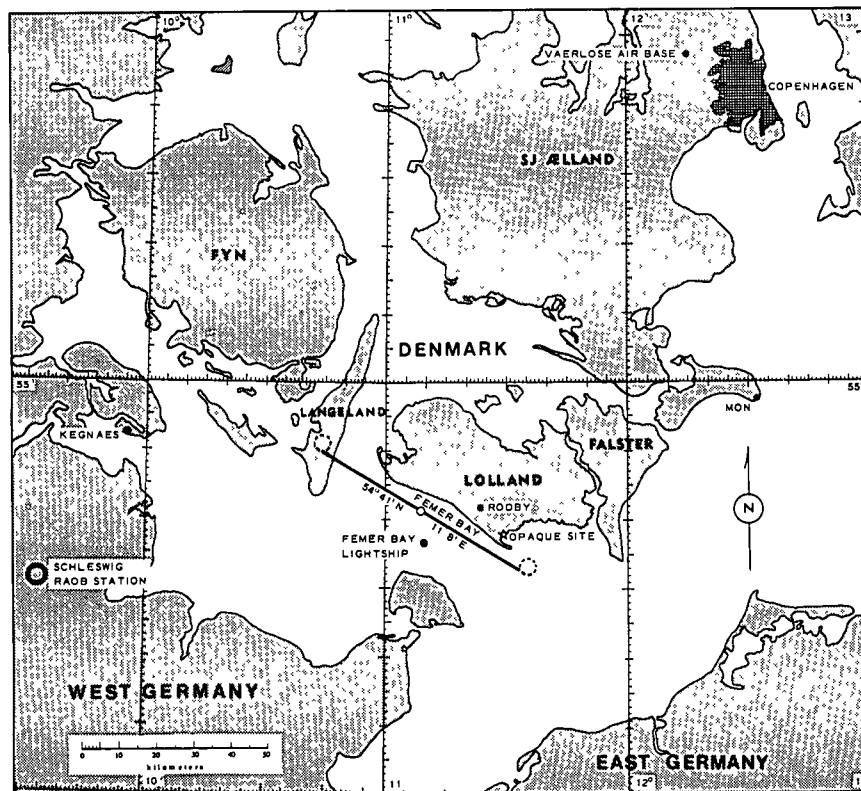

Fig. 1-1b. OPAQUE 11 Flight Track in the Area of the Lolland OPAQUE Station. Latitude and Longitude References are to Flight Track Center Point.

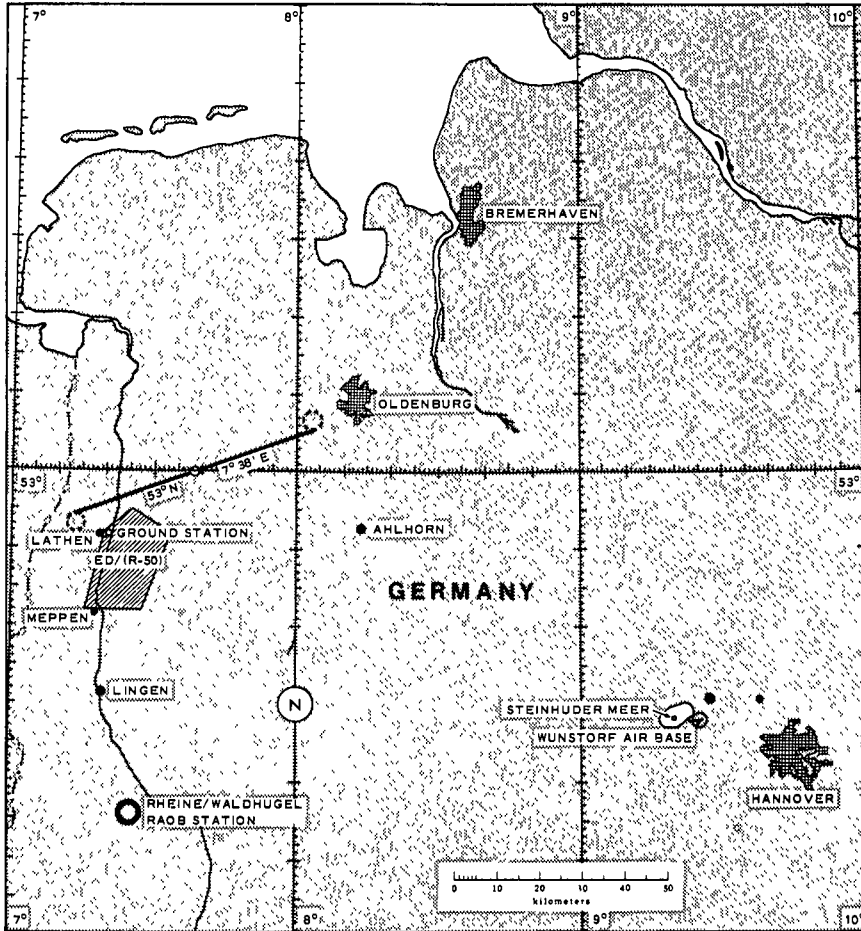

Fig. 1-1c. OPAQUE 11 Flight Track in the Area of the Meppen OPAQUE Station. Latitude and Longitude References are to Flight Track Center Point.

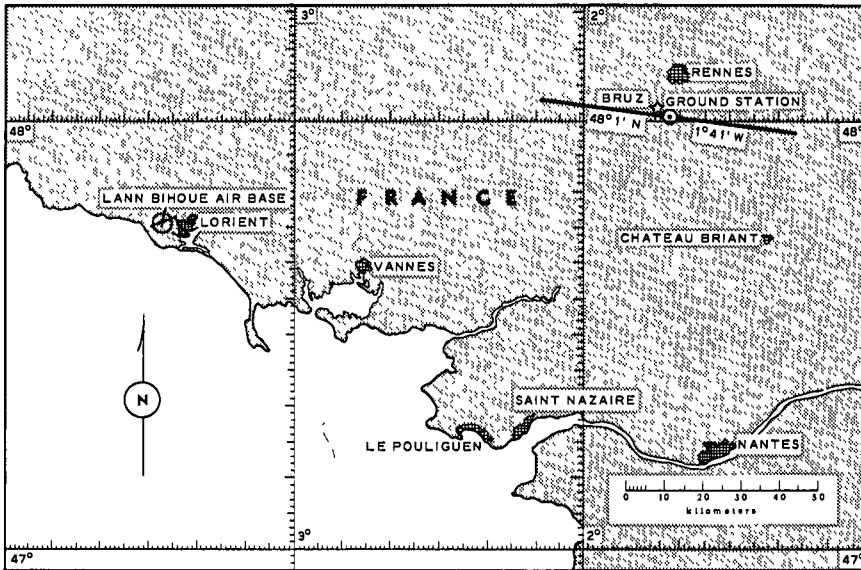

Fig. 1-1d. OPAQUE 11 Flight Track in the Area of the Bruz OPAQUE Station. Latitude and Longitude References are to Flight Track Center Point.

The methods used in the derivation and computation of the included optical properties are summarized in Section 2, and are similar to those presented in AFGL-TR-77-0078, Duntley, *et al.* (1977).

The instrumentation, developed at the Visibility Laboratory and installed in Air Force C-130A Aircraft No. 50022, is reported in detail in AFCRL-70-0137, Duntley, *et al.* (1970a), AFCRL-72-0593, Duntley, *et al.* (1972c), and AFCRL-TR-75-0457, Duntley, *et al.* (1975b). A brief review of the instrumentation as used during the OPAQUE II deployment is presented in Section 3.

The instrumentation used to generate the raw data upon which the reported properties are based consisted of an integrating nephelometer and a dual irradiator. Corroborative data were obtained using a ground-based contrast reduction meter to determine earth-to-space beam transmittances when weather permitted.

The radiometer spectral responses were standardized for the OPAQUE II deployment in the manner illustrated in Fig. 1-2.

Data collection methods were similar to those reported in AFCRL-TR-74-0298, Duntley, *et al.* (1974). The highest straight and level altitude was approximately 6000 meters above ground level (AGL). The basic features of these stylized daytime flight profiles are summarized in Section 4.

The computer techniques used for processing the data included in this report are summarized in Section 5. They are, in general, the same as the techniques reported in AFCRL-TR-75-0457, Duntley, *et al.* (1975b).

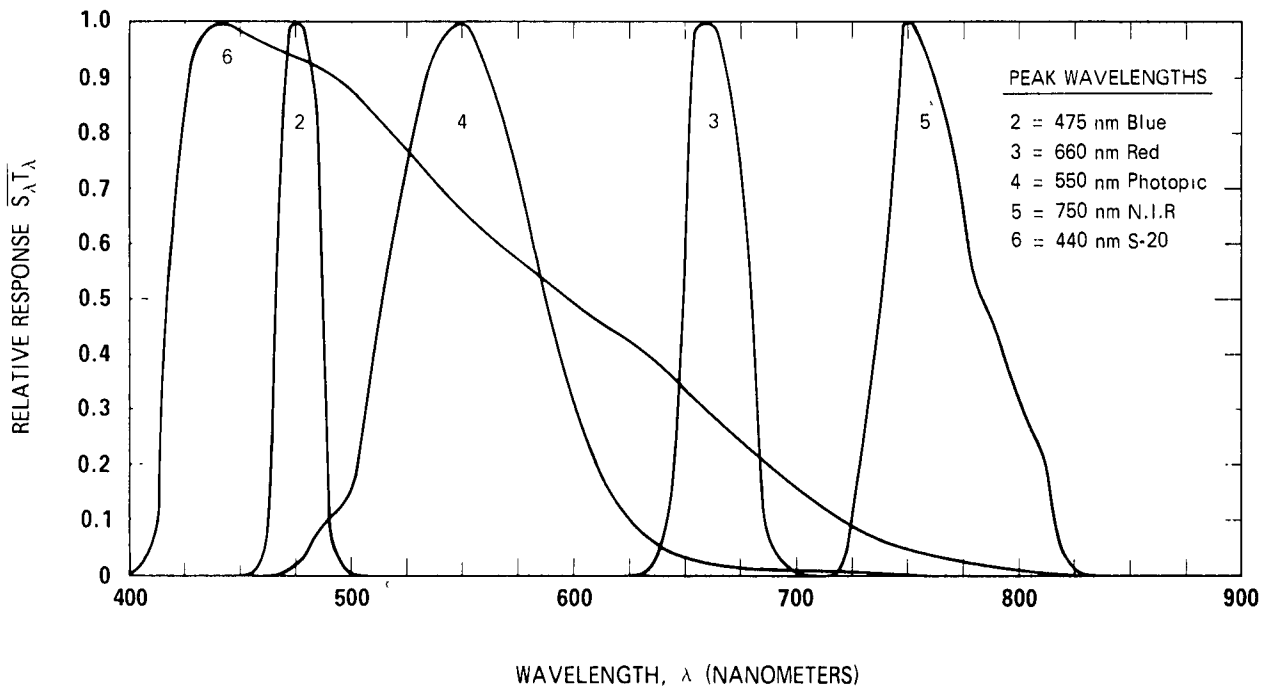

Fig. 1-2. Standard Spectral Responses – Project OPAQUE II.

A general discussion of the weather patterns that predominated in the northern European area during the data collection interval is presented in Section 6. This section, in conjunction with the flight track photographs shown in Section 7, is intended as an aid to the data user's generalized interpretation and evaluation. The inclusion of the graphical presentations is intended to further facilitate the user's rapid orientation with the overall weather situation.

The radiometric data representing 12 separate flights are also presented in Section 7. The presentation format is similar to that used in AFCRL-TR-77-0078, Duntley, *et al.* (1977) since only scattering coefficient and irradiance data are included.

Discussion related to the interpretation and evaluation of the data collected is found in Section 8.

2. THEORY AND COMPUTATIONS

The underlying theoretical concepts and the subsequent computational procedures upon which the Visibility Laboratory bases its determinations of contrast transmission through the troposphere are well documented in our preceding reports. A recent report, AFGL-TR-76-0188, "Airborne Measurements of Optical Atmospheric Properties in Northern Germany," Duntley, *et al.* (1976) is an appropriate reference and contains a substantial set of sample applications and references.

The format included in the following paragraphs has been extracted from the more complete description contained in the reference above. It is designed to support only the selected data appearing in Section 7 herein, and is not complete enough to develop contrast transmittance or any of the other more directional atmospheric optical properties normally associated with the reports in this series.

TOTAL VOLUME SCATTERING COEFFICIENT

A direct measure of air clarity is the atmospheric attenuation coefficient $\alpha(z)$. The parenthetical modifier indicates the altitude z . The attenuation coefficient is the sum of the total volume scattering coefficient and the absorption coefficient. If there is no absorption, the attenuation coefficient is numerically equal to the total volume scattering coefficient $s(z)$.

The total volume scattering coefficient may be defined by the equation

$$s(z) \equiv \int_{4\pi} \sigma(z, \beta) d\Omega \quad (2.1)$$

where $\sigma(z, \beta)$ is the volume scattering function at altitude z and scattering angle β . The integrating nephelometer used to make the total volume scattering coefficient measurements performs the integral in Eq. 2.1 optically. It utilizes a parallel light beam and a cosine-law collector viewing the scattered flux. The instrument is similar in principle to one of four instruments for measuring total volume scattering coefficient described by Beuttell and Brewer (1949).

BEAM TRANSMITTANCE

The beam transmittance $T_p(z, \theta)$ at altitude z , zenith angle θ , and over path length r is obtained

directly from the total scattering coefficient $s(z)$ by means of Eq. 2.2. (Refer also to Boileau (1964), p. 570.) When there is no significant atmospheric absorption in the passbands of the measurements, e.g., from smoke, dust, or smog, the attenuation coefficient $\alpha(z)$ is equivalent to the total volume scattering coefficient $s(z)$. Therefore,

$$T_r(z, \theta) = \exp \left[- \sum_{i=1}^n \alpha(z_i) \Delta r \right] = \exp \left[- \sum_{i=1}^n s(z_i) \Delta r \right] \quad (2.2)$$

where Δr is the incremental path length. The summations are made using the trapezoidal rule. The measured total volume scattering coefficient data are extrapolated to ground level when no ground-based measurements are available. The extrapolation assumes that the scattering particles are the same at all altitudes, but decrease or increase according to the density at each altitude $\rho(z)$:

$$s(0) = \frac{s(z) \rho(0)}{\rho(z)} \quad (2.3)$$

Similarly, upward extrapolations are made to the highest reported altitude above ground level when the highest flight altitude is less. Extrapolation in this case is based on the scattering coefficient measured at highest flight altitude. The densities used for the extrapolations are from the U.S. Standard Atmosphere (1962). The density at each altitude is obtained by truncated Chebyshev expansion using the coefficients for the atmosphere between 0 and 80 kilometers [U.S. Standard Atmosphere Supplements (1966), p. 69].

All altitudes reported are between ground level and 6.3 kilometers maximum. For all paths of sight at zenith angles less than 85 degrees or greater than 95 degrees, Δr equals $\Delta z \sec \theta$ for these altitudes. The Δr is always nonnegative since Δz is defined as $z_1 - z_2$ (the subscripts increase with the flux direction). See Fig. 2-1. The $|\Delta z|$ used is 30 meters (98.4 feet). For zenith angles greater than 95 degrees, the beam transmittance can also be expressed as a function of the vertical beam transmittance $T_r(z, 180^\circ)$ as follows:

$$T_r(z, \theta) = T_r(z, 180^\circ)^{|\sec \theta|} \quad (2.4)$$

for upward paths of sight for zenith angles less than 85 degrees, the beam transmittance can similarly be expressed as a function of the vertical upward transmittance $T_r(0, 0^\circ)$ which equals $T_r(z, 180^\circ)$. The computations described above are useful in determining T_r for a variety of zenith angles, however, the data included in Section 7 of this summary report are restricted to the vertical path only.

ATTENUATION LENGTH

The attenuation length $L(z)$ is defined as the reciprocal of the atmospheric attenuation coefficient

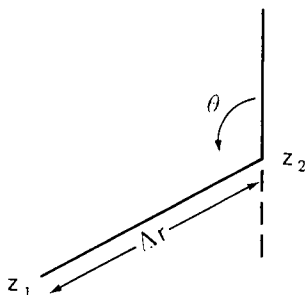

Fig. 2-1. Path Length Geometry for Steeply Inclined Paths of Sight.

$\alpha(z)$. Therefore, when there is no significant absorption, it is also equivalent to the reciprocal of the atmospheric total volume scattering coefficient:

$$L \equiv \frac{1}{\alpha(z)} = \frac{1}{s(z)} \quad (2.5)$$

The equivalent attenuation length $\bar{L}(z)$ is a pseudo-attenuation length which, when combined with its altitude z , can be used directly in the equation [Boileau (1964), Eq. 6.1]

$$T_r(z, \theta) = \exp[-z/\bar{L}(z)] |\sec \theta| \quad (2.6)$$

where $\theta > 95^\circ$ and path length r is between ground level and altitude z . Combining Eqs. 2.6 and 2.2 and appropriately rearranging, the following expression may be obtained for equivalent attenuation length,

$$\bar{L}(z_n) = \frac{z_n}{\sum_{i=1}^n s(z_i) \Delta z} \quad (2.7)$$

For $\theta < 85^\circ$, the $\bar{L}(z)$ values should be interpreted as applying to the object altitude with the sensor at ground level.

EARTH CURVATURE AND REFRACTION

For the paths of sight at zenith angles from 90 to 95 degrees, the Δr for $|\Delta z| = 30$ meters (98.4 feet) is significantly longer at ground level than at 6 kilometers due to the curvature of the earth. Also for upward-looking paths of sight from 85 to 90 degrees, the Δr for $\Delta z = 30$ meters (98.4 feet) is significantly shorter at 6 kilometers than at ground level due to the curvature of the earth. Thus for paths of sight between 85 and 95 degrees in zenith angle, Eqs. 2.4 and 2.6 should not be used. Instead, Eq. 2.2 should be used with the appropriate Δr values.

DOWNWELLING IRRADIANCE

The downwelling irradiance on a horizontal flat plate may be defined by the equation

$$H(z,d) \equiv \int_{2\pi} N(z,\theta',\phi') \cos\theta' d\Omega , \quad (2.8)$$

where $N(z,\theta',\phi')$ is the radiance at altitude z in the direction of zenith angle θ' and azimuth ϕ' . The downwelling irradiance was measured by a dual irradiator which performed the integration in Eq. 2.8 optically with a cosine-law collector. During the ascents and descents of the aircraft when total volume scattering coefficient was being measured, the dual irradiator was simultaneously measuring downwelling irradiance. The downwelling irradiance provides a quantitative measure of the ambient flux levels during the flight.

UPWELLING IRRADIANCE

The upwelling irradiance on a horizontal flat plate is designated by $H(z,u)$. The dual irradiator alternately measured upwelling and downwelling irradiance at low, intermediate, and high altitude during intervals of straight and level flight which preceded or followed the ascents and descents.

ALBEDO

Albedo $A(z)$ is defined as

$$A(z) \equiv H(z,u)/H(z,d) . \quad (2.9)$$

Albedos were determined from the upwelling and downwelling irradiance measurements made with the dual irradiator during the straight and level flight intervals for each flight.

RELATIVE HUMIDITY

The relative humidity is computed using the measured ambient temperature, the measured dewpoint temperature, and their associated partial pressures of water vapor. The relative humidity in percent is computed from the equation

$$RH = (e_v/e_s)100 , \quad (2.10)$$

where e_v is the saturated vapor pressure at dewpoint or frostpoint temperature, and e_s is the saturated vapor pressure at ambient temperature. The saturated vapor pressures over water and over ice are obtained from List (1966).

3. INSTRUMENTATION

The scientific instrumentation utilized for the Project OPAQUE II task was basically the same as that reported in AFCRL-TR-75-0457, Duntley, *et al.* (1975b) and AFGL-TR-76-0188, Duntley, *et al.* (1976). Consequently, the descriptions contained herein have been edited to include only those systems directly related to the scattering coefficient and irradiance data. The total instrumentation package utilized during the Project OPAQUE II deployment is illustrated in Fig. 3-1 and Fig. 3-2.

3.1 RADIOMETRIC SYSTEMS

Of the seven different types of radiometric collector assemblies mounted on board the aircraft, only two have their descriptive summaries included in this report, the integrating nephelometer and the dual irradiator.

INTEGRATING NEPHELOMETER (NEPH) ASSEMBLY

In order to measure and evaluate the total volume scattering coefficient for typical real aerosols, the Visibility Laboratory has devised and built an instrument referred to as an integrating nephelometer. The basic structure of the device consists of the subassembly illustrated in Fig. 3-3 and an enclosing light tight box. In the airborne version, ram air driven by the aircraft's forward velocity is routed through the box via four one-inch diameter inlet tubes and four one and one-half-inch diameter exhaust tubes.

In its operational mode, the integrating nephelometer measures the radiant flux scattered by the transient aerosol as it passes through the geometrically well defined flux beam from a high intensity projector. The scattered flux is sequentially collected through one of three different optical channels: two telescopes, each having 2-degree circular fields of view oriented to collect the flux scattered in the $\beta=30^\circ$ and $\beta=150^\circ$ directions, and one 2π irradiator assembly oriented to collect the flux scattered in all scattering angles between $\beta = 5^\circ$ and $\beta = 172.5^\circ$. From these measurements plus the measurement of a well defined calibration flux level, the directional scattering functions $\sigma(30^\circ)$ and $\sigma(150^\circ)$ and the total volume scattering coefficient s may be derived.

In its simplest form, the equation which is used to compute the total volume scattering coefficient is

$$s = \frac{s_H K}{r_H F}, \quad (3.1)$$

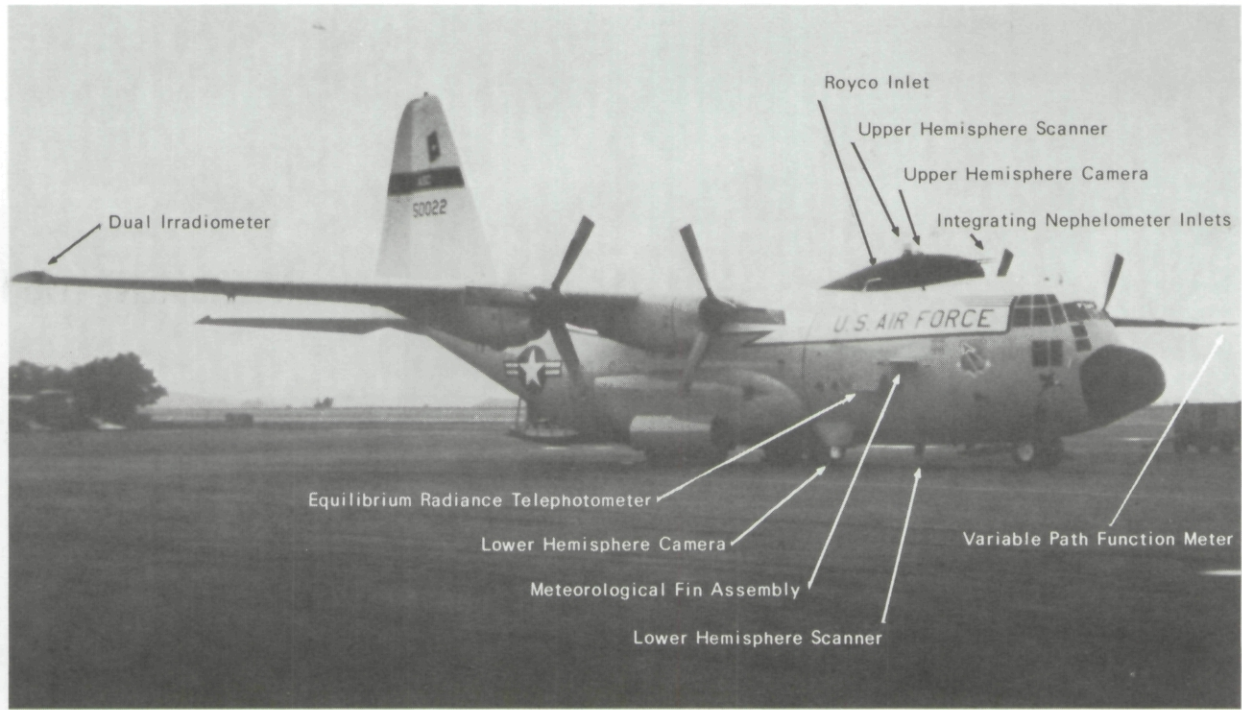

Fig. 3-1. C-130 Airborne Instrument System.



Fig. 3-2. Ground-Based Instrument System.

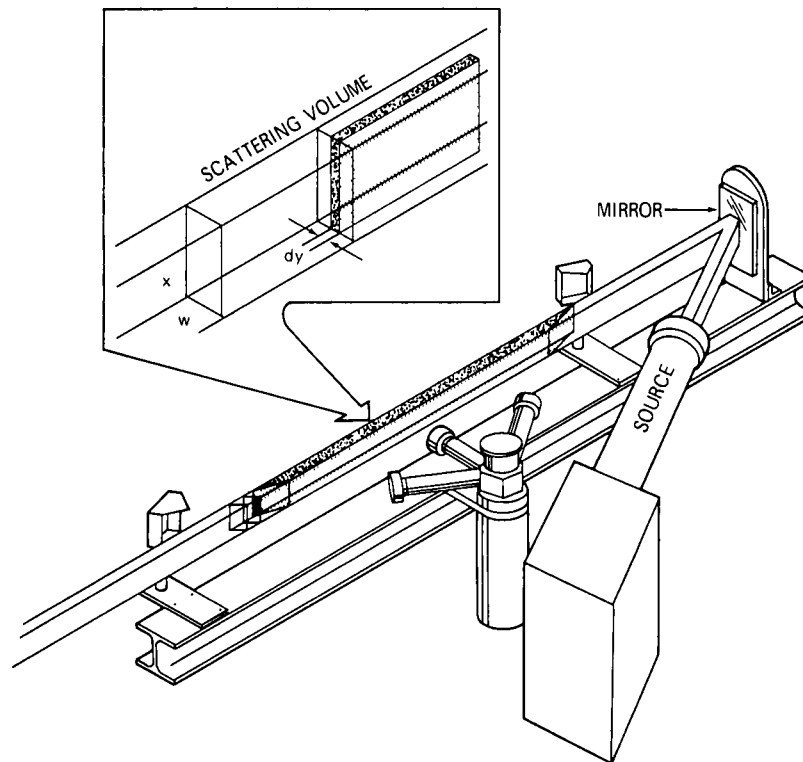

Fig. 3-3. Artist's Rendition of Modified Integrating Nephelometer.

where

I_s is the flux scattered from the beam and collected by the instrument's irradiometer channel while in the operational mode, and

I_c is the flux reflected from a diffusely reflecting calibration plaque and collected by the irradiometer channel while the instrument is in the calibration mode.

The constants K and F are rather extensive integral expressions which relate the geometry of the scattering volume with respect to the irradiometer cap location, the irradiance distribution in the flux beam, the transmittance and reflectance characteristics of the collector cap and calibration plaque, and the most probable shape of the scattering function associated with the sample aerosol.

The ratio K/F for the airborne integrating nephelometer has been computed using the Rayleigh volume scattering function and a set of ten additional volume scattering functions representative of a broad range of real atmospheres as determined from Barteneva (1960). Using the in-flight measured values of $\sigma(30^\circ)$ and $\sigma(150^\circ)$ from the nephelometer, the most probable scattering function for the sample aerosol can be selected, and the appropriate K/F factor applied. It is the application of this procedure for determining the most probable scattering function from measured data, and applying this supplementary knowledge of the character of the sample aerosol as a correction to the measurement for total scattering coefficient which makes this instrument unique and potentially superior for research applications.

The mechanical and optical configurations of the integrating nephelometer utilized on the OPAQUE II deployment have changed from those reported in AFCRL-70-0137, Duntley, *et al.* (1970a). The basic change is that the projector beam has been optically folded by inserting a plane mirror into the beam between the projector and the beginning of the scattering volume. This optical folding has enabled the shortening of the mechanical frame and housing such that the entire assembly can be enclosed in an aerodynamic shroud. The modified nephelometer is illustrated in AFCRL-TR-75-0457, Duntley, *et al.* (1975b). The operating characteristics of the revised nephelometer were discovered to suffer from stray light problems during the post deployment analysis of the OPAQUE II data, and further modification was accomplished subsequent to its return to the Laboratory. No further evidence of stray light contamination has been observed.

The modified nephelometer is enclosed in the modified radome shown on top of the aircraft in Fig. 3-1, and an artist's rendition of the modified arrangement of the internal subassemblies is illustrated in Fig. 3-3.

DUAL IRRADIOMETER (DI) ASSEMBLY

The dual irradiator assembly is a two-channel irradiator. It has two optical input channels but only one optical output. A rotating prism subassembly allows the system operator to select either input channel for optical coupling with the output channel, while simultaneously occulting the other. The resultant time-sharing of a single detector assembly yields a device optimized for ratio type measurements.

The flat plate diffuse collector surfaces used in this assembly are mechanically corrected to yield cosine collection characteristics between 0 and 90 degrees which are within ± 2 percent of true cosine for all angles of incidence between 0 and 80 degrees.

The dual irradiator assembly is mounted on the aircraft wingtip so that the flat plate collectors are horizontal during normal straight and level (ST&LV) flight elements. In this configuration the upper channel receives radiant flux from the entire hemisphere above the aircraft, and the lower channel receives radiant flux from the entire hemisphere below the aircraft. These measurements of downwelling and upwelling irradiance can be used both in the calculation of directional terrain reflectances and in intersystem data validation checks.

3.2 METEOROLOGICAL SYSTEMS

All of the meteorological systems utilized in this project were purchased items; the operating characteristics of each are available in the appropriate manufacturer's brochures. For use in Project OPAQUE II, the meteorological systems were unchanged from the configurations reported in AFCRL-72-0593, Duntley, *et al.* (1972c).

The airborne meteorological package consisted of one Royco Model 220 particle counter, one Cambridge Model 137-C3 aircraft hygrometer system, one AN/AMQ-17 aerograph set, and two Bourns aneroid pressure transducers.

Since all of the meteorological systems were described in AFCRL-72-0255, Duntley, *et al.* (1972a) and AFCRL-72-0593, Duntley, *et al.* (1972c), no further discussion is included in this report.

3.3 CONTROL AND COMMUNICATION SYSTEMS

The basic control panels, consoles, and other support facilities associated with the airborne instrument system are described fully in AFCRL-70-0137, Duntley, *et al.* (1970a) and the updated configurations are reported in AFCRL-72-0593, Duntley, *et al.* (1972c).

3.4 PHOTOGRAPHIC SYSTEMS

Photographic documentation of the test environment performed simultaneously with the radiometric and meteorological measurements has always been a highly desirable adjunct to any field activity. For Project OPAQUE II, this photographic capability was accomplished by the Visibility Laboratory through the use of two camera systems.

AIRBORNE AUTOMAX G-1 CAMERA SYSTEM

Two 35-millimeter Automax G-1 cameras, modified to accept Traid 735 Periphoto (180-degree) lenses, were mounted on the project aircraft (Fig. 3-1). One camera was oriented to photograph the 2π upper hemisphere and the other covered the 2π lower hemisphere. Either or both cameras may be run in either cine or single-frame modes at the discretion of the operator.

The photographs from these cameras are used only as general background for the interpretation of the radiometric measurements. Thus, no special controls are placed upon the film or its processing. For this general-purpose application, the cameras are normally loaded with Kodak Ektacolor Professional S, No. 5026 film. Typical photographs from this system are used as illustrations in Section 7 of this report and were shot with a fixed f6.3 aperture in the single-frame mode.

GROUND-BASED SOLIGOR SYSTEM

The ground-site documentation photographs have historically been limited to 35-millimeter color snapshots, taken on a casual basis during lulls in the experimental sequences. For Project OPAQUE II this procedure was supplemented with a scheduled routine of site photographs using a Soligor Conversion Fisheye lens. This lens possesses almost universal adaptability to a wide variety of cameras and prime lenses. During Project OPAQUE II it was used on a Yashica, Lynx 1000.

3.5 RADIOMETRIC CALIBRATION PROCEDURES

All the radiometers used in this project are calibrated in essentially the same manner. In each case, the system is calibrated first by determining its relative flux versus high voltage characteristics over the anticipated operating span and second by establishing known absolute flux levels on this voltage curve. The entire calibration procedure is conducted by using standard photometric practices, a 3-meter optical bench, and incandescent standards of luminous intensity traceable to the National Bureau of Standards.

A detailed discussion of these calibration procedures is contained in AFCRL-70-0137, Duntley, *et al.* (1970a), AFGL-TR-76-0188, Duntley, *et al.* (1976), and most of the intervening reports in this series. The discussion therefore will not be repeated herein.

A typical data sheet for the absolute calibration of a Project OPAQUE II radiometer is shown in Fig. 3-4. Five different levels of input radiance are used in the determination of the calibration constant for the system. The calibration constant is referred to as the zero scale value and is labeled ZSV on the calibration forms.

CALIBRATION CORRECTION FACTORS

Several calibration correction factors are used with the calibration data illustrated in Fig. 3-4 to generate the calibration constants listed in Table 3.1. In general, the factors are used at will to convert radiometric units into photometric units and reconvert them, and to adjust the value of measurements taken with an instrument having a nearly standard spectral response to the value that would have been obtained using the exact standard spectral response specified in Section 3.6.

ABSOLUTE CALIBRATION FORM

(30) NEPH-1 SIGMA (21253 NS) (IRRADIOMETER) TAKEN ON 9/21/76 (PREOQUE) DEPLOYMENT

FILTER NO. 4 (XENON) 5500 DEGREES KELVIN

SPAN ID	DI CM	TOTAL DIST. CM	TOTAL DIST. SQ. CM.	CALC. TARGET BR *	DETEC. RAW OUTPUT	LOG OF (K0/K)	RAW ZSV	PERCENT DIFF OF RAW AVG	AVG RAW ZSV	F1 LUM. TO RAD. WATTS/LUM.	F2 COLOR MATCH	CORRECTED ZSV
1	40	116.300	1.353E 04	7.580E-05	493	0	0	0	5.138E-05	1.050E-03	1.017E 00	5.487E-08
2	70	146.300	2.140E 04	4.794E-05	471	-.133	4.935E-05	4.0				
3	120	196.300	3.853E 04	2.663E-05	432	-.285	5.133E-05	1.1				
4	200	276.300	7.634E 04	1.344E-05	339	-.563	4.940E-05	3.8				
5	300	376.300	1.416E 05	7.240E-06	343	-.551	5.136E-05	0				
3	120	196.300	3.853E 04	2.663E-05	427	-.313	5.479E-05	-6.6				
2	70	146.300	2.140E 04	4.794E-05	466	-.147	5.337E-05	-3.9				
1	40	116.300	1.353E 04	7.580E-05	493	0	0	0				

LINEARITY MAXIMUM = (473) APPLIED CUTOFF = (-A39)
 LINEARITY CALIB. END = (-B39) FULL DARK = (-958) CUTOFF = (-B39)
 * CALCULATED ILLUMINANCE IN LUMENS/SQ. CM.

RAW ZSV STD = (1.9011E-06) FRACT. STD = (3.70) PERCENT 75V IN WATTS/SQ. CM. IS 5.487E-08
 WITH UNIT CONVERSION FACTOR OF (127300.00000), TO CHANNEL UNITS FROM (W/ SQ. CM)
 IT (W/ SQ. CM MICRO M) THE NEW ZSV IN WATTS(SQ. M MICRO M) IS 6.98461E-03

THIS FILTER IS PSEUDO-PHOTOPL. TO CONVERT TO TRUE PHOTOPIC STANDARD (SEE TECHNICAL MEMORANDUM AV71-0037)
 FOR DAYLIGHT DATA MULTIPLY BY 72.000LJMN-UM / WATT. PHOTOPIC ZSV IS 5.02892E-01 LUMEN/ SQ M.
 FOR NIGHT TIME LIGHTING MULTIPLY BY 69.340LJMN-UM / WATT. PHOTOPIC ZSV IS 4.77128E-01 LUMEN/ SQ M.
 FOR NEPHELOMETER ONLY MULTIPLY BY 72.216LJMN-UM / WATT. PHOTOPIC ZSV IS 5.04100E-01 LUMEN/ SQ M.

MV FLUCTUATION DATA DURING EACH CALIB MEASUREMENT			CALIBRATION LAMP IDENTIFICATION		CALIBRATION TARGET DATA	
SPAN ID	STD. DEV. IN MV	FRACT STD DEV IN PERCENT	SERIAL NUMBER =	VLA0201	REFLECTANCE OF PATH ATTENUATOR(PERCENT) =	5.0
1	0	0	LAMP INTENSITY =	20.52	REFLECTANCE OF CALIBRATION TARGET(PERCENT) =	100.0
2	5.000E-01	1.062E-01	DISTRIBUTION TEMPERATURE =	2854	TOTAL = LAMP DISTANCE = D1 + D2. C2(CM) =	70.3
3	5.000E-01	1.159E-01	MONITOR CURRENT CHANNEL =	/	PHOTOMETER DATA CHANNEL =	1
4	4.425E-01	1.137E-01				
5	0	0				
3	3.416E-01	8.900E-02				
2	5.123E-01	1.199E-01				
1	5.171E-01	1.329E-01				

Fig. 3-4. Typical Absolute Calibration Form.

These correction factors are discussed at length in AFCRL-70-0137 and AFCRL-72-0461, Duntley, *et al.* (1970a and 1972b). Thus, they are not discussed further at this time.

3.6 STANDARD RESPONSE CHARACTERISTICS FOR BROAD BAND SENSORS

All the radiometric instruments both ground-based and airborne used by the atmospheric visibility branch are equipped with automatic filter changing assemblies. Thus, any one of five different spectral filters can be interposed into each instrument's optical path. The combination of the sensor sensitivity S_λ and the filter transmittance T_λ is the resultant sensitivity of the filtered phototube $S_\lambda T_\lambda$. The standard responses which each optical system attempts to duplicate are indicated as $\overline{S_\lambda T_\lambda}$, and are illustrated in Table 3.3. No system has true photopic response, Filter Code 9, but this ideal response is included for comparative purposes only.

A summary of the response characteristics of the standards for Project OPAQUE II is presented in Table 3.2. The first four columns give filter code, peak wavelength, and response area, terms which are fully defined in preceding reports such as AFGL-TR-76-0188, Duntley, *et al.* (1976). The values for inherent solar properties are in columns 5, 6, and 7, and the Rayleigh limits are in columns 8, 9, and 10. The table was produced by Program RAYLIMIT.

Table 3.1

Project OPAQUE II

Radiometer Calibration Constants (ZSV) and Related Fractional Standard Deviations (δ) For Daylight Flights

Radiometer Identification		Calib Mode	Calib Units	Filter 2		Filter 4		Filter 3		Filter 5		Average Percent for System
System	MPT SN			ZSV	$\delta\%$	ZSV	$\delta\%$	ZSV	$\delta\%$	ZSV	$\delta\%$	
NEPH1 Σ	21253	Out	w/m ² μ m	2.00E-02	2	6.98E-03	4	3.88E-02	1	4.30E-01	2	2
NEPH1 β 30	21253	Out	w/ Ω m ² μ m	1.76E-02	1	7.25E-03	1	4.38E-02	2	6.09E-01	2	2
DI	9861	In	w/m ² μ m	3.41E+04	7	8.73E+03	3	2.24E+04	4	1.60E+04	3	4

Table 3.2

Spectral Characteristics Summary for Project OPAQUE II

Spectral Characteristics for Project OPAQUE II				Inherent Sun Properties (Johnson)			Rayleigh Atmosphere Properties (15°C)		
Filter Code No.	Peak Wavelength (nm)	Mean Wavelength (nm)	Response Area (nm)	Irradiance (w/m ² μ m)	Radiance (w/ Ω m ² μ m)		Attenuation Length (m)	Total Scattering Coefficient (per m)	Vertical Beam Transmittance
					Average	Center			
2	475	478	19.9	2.14E+03	3.13E+07	4.07E+07	4.84E+04	2.07E-05	0.839
3	660	664	30.2	1.57E+03	2.30E+07	2.75E+07	1.86E+05	5.41E-06	0.955
4	550	557	78.5	1.90E+03	2.78E+07	3.47E+07	8.93E+04	1.15E-05	0.907
5	750	765	50.4	1.23E+03	1.80E+07	2.10E+07	3.28E+05	3.08E-06	0.974
6	440	532	183.5	1.91E+03	2.80E+07	3.55E+07	7.22E+04	1.64E-05	0.867
9	555	560	106.9	1.89E+03	2.77E+07	3.45E+07	9.22E+04	1.15E-05	0.907

Table 3.3

Relative Spectral Response of Standards for Project OPAQUE II

Filter Identification and Mean Wavelength							Filter Identification and Mean Wavelength						
Wave-length (nm)	No 2 Blue 478nm	No 3 Red 664nm	No 4 Pseudo- Photopic 557nm	No 5 NIR 765nm	No 6 S-20 532nm	No 9 True Photopic 560nm	Wave length (nm)	No 2 Blue 478nm	No 3 Red 664nm	No 4 Pseudo- Photopic 557nm	No 5 NIR 765nm	No 6 S-20 532nm	No 9 True Photopic 560nm
400	0	0	0	0	0	0 0004	615	0	0	0 1680	0	0 4500	0 4412
405	0	0	0	0	0 0 0129	0 0006	620	0	0	0 1300	0	0 4390	0 3810
410	0	0	0	0	0 0 0258	0 0012	625	0	0	0 1055	0	0 4260	0 3210
415	0	0	0	0	0 0 2969	0 0022	630	0	0	0 0810	0	0 4130	0 2650
420	0	0	0	0	0 0 5680	0 0040	635	0	0 0020	0 0657	0	0 3935	0 2170
425	0	0	0	0	0 0 7605	0 0073	640	0	0 0486	0 0504	0	0 3740	0 1750
430	0	0	0	0	0 0 9530	0 0116	645	0	0 1798	0 0411	0	0 3545	0 1382
435	0	0	0	0	0 0 9765	0 0168	650	0	0 5531	0 0318	0	0 3350	0 1070
440	0	0	0	0	0 1 0000	0 0230	655	0	0 9948	0 0268	0	0 3190	0 0816
445	0	0	0	0	0 0 9920	0 0298	660	0	1 0000	0 0218	0	0 3030	0 0610
450	0	0	0	0	0 0 9840	0 0380	665	0	0 9421	0 0188	0	0 2845	0 0446
455	0	0	0	0	0 0 9720	0 0480	670	0	0 8625	0 0157	0	0 2660	0 0320
460	0 0070	0	0	0	0 0 9600	0 0600	675	0	0 7482	0 0139	0	0 2480	0 0232
465	0 1487	0	0	0	0 0 9510	0 0739	680	0	0 4774	0 0120	0	0 2300	0 0170
470	0 8481	0	0	0	0 0 9420	0 0910	685	0	0 1585	0 0105	0	0 2105	0 0119
475	1 0000	0	0 0172	0	0 0 9355	0 1126	690	0	0 0495	0 0090	0	0 1910	0 0082
480	0 9329	0	0 0343	0	0 0 9290	0 1390	695	0	0 0166	0 0080	0	0 1755	0 0057
485	0 8304	0	0 0677	0	0 0 9175	0 1693	700	0	0	0 0070	0	0 1600	0 0041
490	0 1790	0	0 1010	0	0 0 9060	0 2080	705	0	0	0 0061	0	0 1445	0 0029
495	0 0292	0	0 1185	0	0 0 8920	0 2586	710	0	0	0 0053	0	0 1290	0 0021
500	0	0	0 1360	0	0 0 8780	0 3230	715	0	0	0 0048	0	0 1170	0 0015
505	0	0	0 2635	0	0 0 8560	0 4073	720	0	0	0 0042	0	0 1050	0 0010
510	0	0	0 3910	0	0 0 8340	0 5030	725	0	0	0 0038	0 1005	0 0938	0 0007
515	0	0	0 5085	0	0 0 8135	0 6082	730	0	0	0 0033	0 2010	0 0826	0 0005
520	0	0	0 6260	0	0 0 7930	0 7100	735	0	0	0 0030	0 4155	0 0723	0 0004
525	0	0	0 7345	0	0 0 7715	0 7932	740	0	0	0 0026	0 6300	0 0619	0 0003
530	0	0	0 8430	0	0 0 7500	0 8620	745	0	0	0 0025	0 8150	0 0558	0 0002
535	0	0	0 9065	0	0 0 7250	0 9149	750	0	0	0 0023	1 0000	0 0497	0 0001
540	0	0	0 9700	0	0 0 7000	0 9540	755	0	0	0 0020	0 9595	0 0416	0 0001
545	0	0	0 9850	0	0 0 6785	0 9803	760	0	0	0 0018	0 9190	0 0335	0 0001
550	0	0	1 0000	0	0 0 6570	0 9950	765	0	0	0 0017	0 8495	0 0292	0
555	0	0	0 9665	0	0 0 6385	1 0002	770	0	0	0 0016	0 7800	0 0249	0
560	0	0	0 9330	0	0 0 6200	0 9950	775	0	0	0 0014	0 6620	0 0206	0
565	0	0	0 8685	0	0 0 6030	0 9786	780	0	0	0 0013	0 5440	0 0162	0
570	0	0	0 8040	0	0 0 5860	0 9520	785	0	0	0 0012	0 4890	0 0144	0
575	0	0	0 7195	0	0 0 5700	0 9154	790	0	0	0 0012	0 4340	0 0125	0
580	0	0	0 6350	0	0 0 5540	0 8700	795	0	0	0 0012	0 3720	0 0107	0
585	0	0	0 5525	0	0 0 5385	0 8163	800	0	0	0 0011	0 3100	0 0088	0
590	0	0	0 4700	0	0 0 5230	0 7570	805	0	0	0 0005	0 2675	0 0075	0
595	0	0	0 3950	0	0 0 5060	0 6949	810	0	0	0	0 2250	0 0062	0
600	0	0	0 3200	0	0 0 4890	0 6310	815	0	0	0	0 1125	0 0031	0
605	0	0	0 2630	0	0 0 4750	0 5668	820	0	0	0	0	0	0
610	0	0	0 2060	0	0 0 4610	0 5030							

4. DATA COLLECTION METHODS

During Project OPAQUE II, two independent activities were maintained simultaneously. The operation of the airborne instrument system was one activity and that of the ground-based instrument system was the other. The procedural routine was for each system to run full data collection sequences at every opportunity, on a daily schedule, as weather permitted.

4.1 AIRBORNE SYSTEM

The data collection sequence for the airborne system was broken into five standardized elements: (1) preflight warmup and calibration check, (2) straight and level sequences, (3) vertical profile sequences, (4) in-flight calibration checks, and (5) post-flight calibration check.

An illustration of our typical flight pattern which was used for most OPAQUE II flights, is shown in Fig. 4-1. In this stylized pattern, two basic elements, the straight and level (ST&LV) and the vertical profile (V-PRO), are combined to yield the total mission flight plan. A description of these two pattern elements and the calibration elements is detailed in AFCRL-72-0255, Duntley, *et al.* (1972a), modified in AFCRL-TR-75-0457, Duntley, *et al.* (1975b), and summarized with the exception of the pre- and post-flight checks in the following paragraphs.

1. Straight and Level runs (ST&LV), Mode 03 – The ST&LV runs are primarily 2π scanner runs. The measurement of upper and lower hemisphere radiance distributions has top priority. One sky mode scanner pattern (192 seconds) plus one sun mode scanner pattern (64 seconds) are run at each altitude with each of the two optical filters.

During ST&LV runs the aircraft should maintain a fixed heading, a constant indicated air-speed of 150 knots or less, and a $2\frac{1}{2}$ -degree nose-high flight attitude.

2. Vertical Profile runs (V-PRO), Mode 07 – The V-PRO runs are primarily integrating nephelometer and variable path function meter runs. The measurement of the total scattering coefficient profile has top priority. Second priority is measurement of the vertical path function profile. Each V-PRO ascent or descent is made using a single filter.

During the V-PRO runs the aircraft should maintain a fixed heading, with the sun off the left wingtip, and a flight attitude not exceeding 4 degrees nose down or 8 degrees nose up.

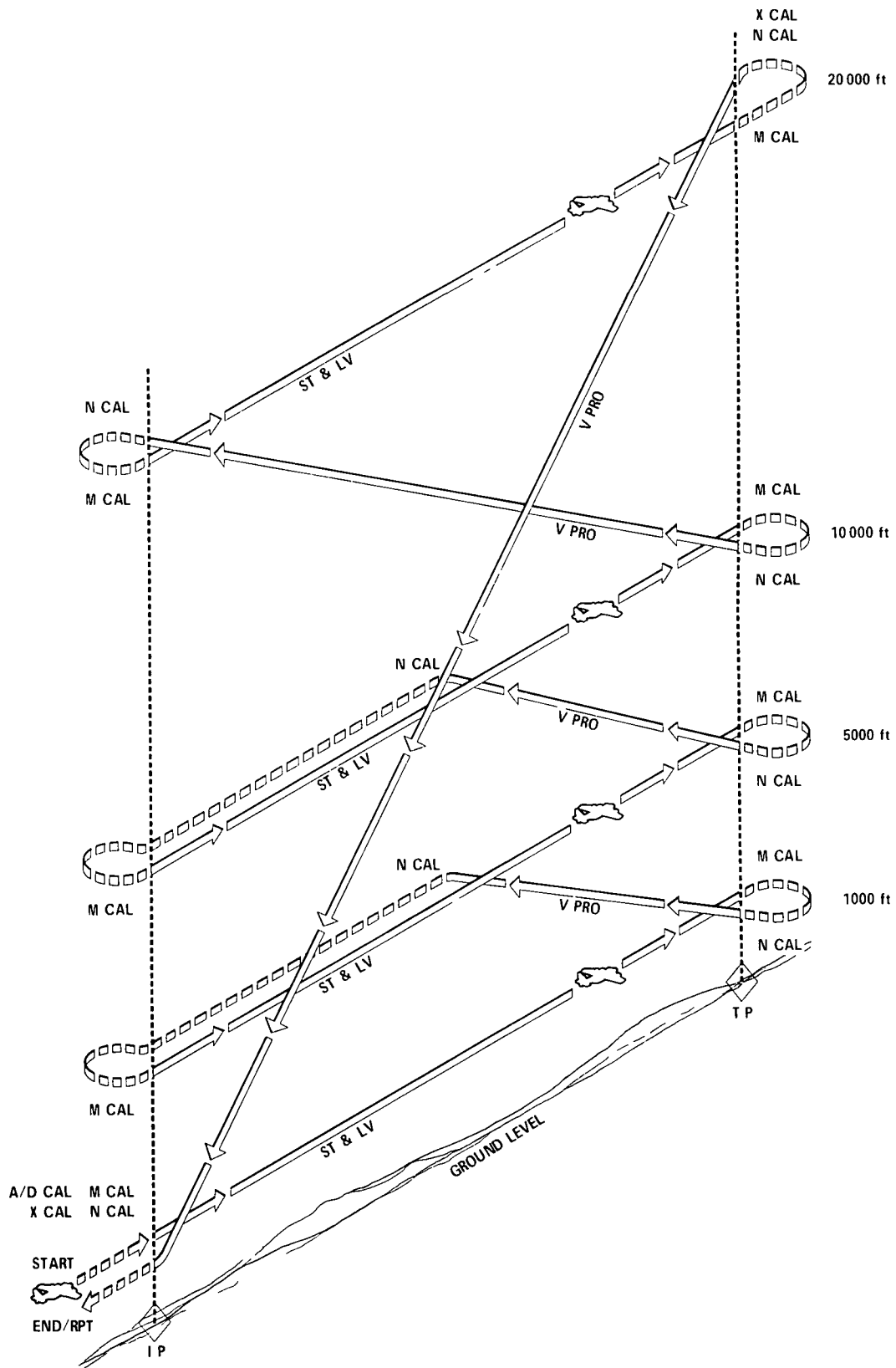

Fig 4-1 Typical Visibility Laboratory Flight Profile

An average rate of climb or descent of 1200 feet/minute is optimum, and airspeed is not critical, but should remain constant once established

- 3 Cross-Calibration Climbs (X-CAL), Mode 08 – The X-CAL climbs are specifically designed to validate the performance of the UHS LHS, and ERT radiometer systems. The simultaneous measurement of a common uniform segment of sky by these three radiometers has top priority. Two X-CAL climbs are associated with each standard profile, one preceding the first ST&LV run and the second following the last ST&LV run. Both sky mode and sun mode measurements are made with the UHS system.

During the 4-minute X-CAL climb the aircraft should maintain a fixed heading, with the sun in the aft hemisphere, and a 5-degree nose-high flight attitude. The aircraft should be flown directly toward the clearest and most uniform portion of the sky as practical.

- 4 Calibration Blocks (A/D CAL), Mode 00, M-CAL, Mode 01, N-CAL Mode 09 – The 32-second blocks of calibration data are inserted periodically throughout the entire data mission. They are designed to provide calibration update information to the post-flight computer processing sequences. There are 21 assorted calibration blocks associated with each (2+4) profile.

During these calibration blocks there are no project-imposed requirements upon aircraft speed or attitude.

GENERAL FLIGHT PATTERN

The standard (2+4) profile is illustrated in Fig. 4-1. In this profile, ST&LV data runs are made using two different spectral filters at each of four altitudes. The ascent V-PRO is made using the first of the two filters, and the descent V-PRO is made using the second. After the descent V-PRO, the entire sequence is repeated using a second pair of filters.

The idealized flight profile would result in all ground tracks falling on a single line running between the Initial Point (I P) and the Turning Point (T P). See Fig. 4-1. In practice, the ST&LV elements are actually stacked in a slab of atmosphere approximately 30 miles long, 0.5 mile wide, and 4 miles high.

Periodically, in response to specialized data requirements or weather conditions, supplementary flight patterns are added to the mission profile. For OPAQUE II, many different patterns were used in addition to the standard (2+4) profile. A pattern made up of a (2+3) profile, i.e., two spectral filters at each of three altitudes, was used, as was a (2+2) profile, i.e., two spectral filters at each of two altitudes. In addition a (1+4) and a (1+2) profile were used, i.e., one spectral filter at four and two altitudes, respectively. Two of the 12 flights had complete V-PRO data runs, but only partial ST & LV data sets.

At the conclusion of each mission, the radiometric data which were recorded and stored on magnetic tape were returned to the Visibility Laboratory for computer reduction and analysis.

4.2 GROUND-BASED SYSTEM

The ground-based data collection sequence was designed to supplement the airborne data whenever the aircraft was operating in the immediate vicinity. However, it is also complete enough to stand alone when the aircraft mission is diverted or aborted.

During the OPAQUE II deployment, only the fly-away Contrast Reduction Meter (CRM) kit was available as a ground station. The primary function of the CRM system is to determine the earth-to-space beam transmittance for comparison with the data from the airborne systems. The basis for the measurement techniques utilizing the CRM was first presented by Gordon, *et al.* (1963) and validated by Duntley, *et al.* (1964). It is also discussed in Edgerton (1967) and summarized in Gordon, *et al.* (1973). A similar configuration of the device is described in Duntley, *et al.* (1970b).

The operational and computational procedures related to the CRM system are described in detail in Duntley, *et al.* (1972b), and briefly summarized in the following paragraph.

Four basic measurements using the CRM are required in order to provide proper inputs to the computation of earth-to-space universal contrast transmittance. They are:

1. Apparent Solar Radiance.
2. Path Radiance, i.e., Sky Radiance, at an appropriate scattering angle from the sun.
3. Total Downwelling Irradiance.
4. Inherent Background Radiance, i.e., generally a selected terrain radiance.

Since the CRM is conceived as a clear day system, requiring clear skies, its daily data collection schedule was often cut short, or aborted by poor weather during the OPAQUE II deployment. Under highly variable weather conditions, priority is assigned to measurements of apparent solar radiance in order to retrieve a maximum number of determinations for atmospheric beam transmittance. These measurements are recorded manually for subsequent insertion into the automatic data processing and evaluation procedure.

5. DATA PROCESSING

As in any reasonably complex, multi-input sampled data system, there is a large amount of data handling required before the scientific analyst ever sees the package. The degree of data processing sophistication utilized during this contract interval is illustrated in Fig. 5-1 and 5-2. In these generalized flow charts, the basic functional steps used in the data processing of the raw field data are clearly specified. They do not illustrate, however, all of the miscellaneous routines used for data base management and special diagnostic purposes. A more complete description of each phase of the processing sequence is contained in AFCRL-72-0255, AFCRL-72-0593, Duntley, *et al.* (1972a and c), and AFCRL-TR-75-0457, Duntley, *et al.* (1975b).

5.1 AIRBORNE DATA

As described in AFCRL-72-0255, Duntley, *et al.* (1972a), several classes of data are recorded during an airborne data set: (1) radiometer outputs, (2) selector control codes, (3) transducer orientation and flight attitude signals, and (4) calibration voltages, etc. All systems, regardless of type, have been designed for an electrical output between 0 and ± 1 volt dc for full scale. The 42-channel data logger has a least count of ± 1 millivolt and records in digital format at a multiplex rate of 240 samples per second and a tape rate of 3.56 inches per second at a recording density of 200 bits per inch.

Several major improvements to the airborne data processing procedure have been implemented during the interval since AFCRL-72-0593, Duntley, *et al.* (1972c) and AFCRL-TR-75-0457, Duntley, *et al.* (1975b). The insertion of these programs is summarized in AFGL-TR-76-0188, Duntley, *et al.* (1976) and is illustrated in Fig. 5-1. These programs, and the increased diagnostic capabilities that their usage has enabled, have materially improved the quality of the upper hemisphere radiance maps, and thus the quality of all subsequently computed optical atmospheric properties.

In order to produce the data included in this short form report, it was not necessary to run the programs illustrated in the upper portion of Fig. 5-1. That is, those programs related to the processing of automatic scanner data, MIRESCAN, SCANTSUM, etc., were bypassed. In this manner the AVIZC130 runs were shortened to only the first overlay for the production of scattering coefficient and beam transmittance profiles.

AIRBORNE DATA PROCESSING:

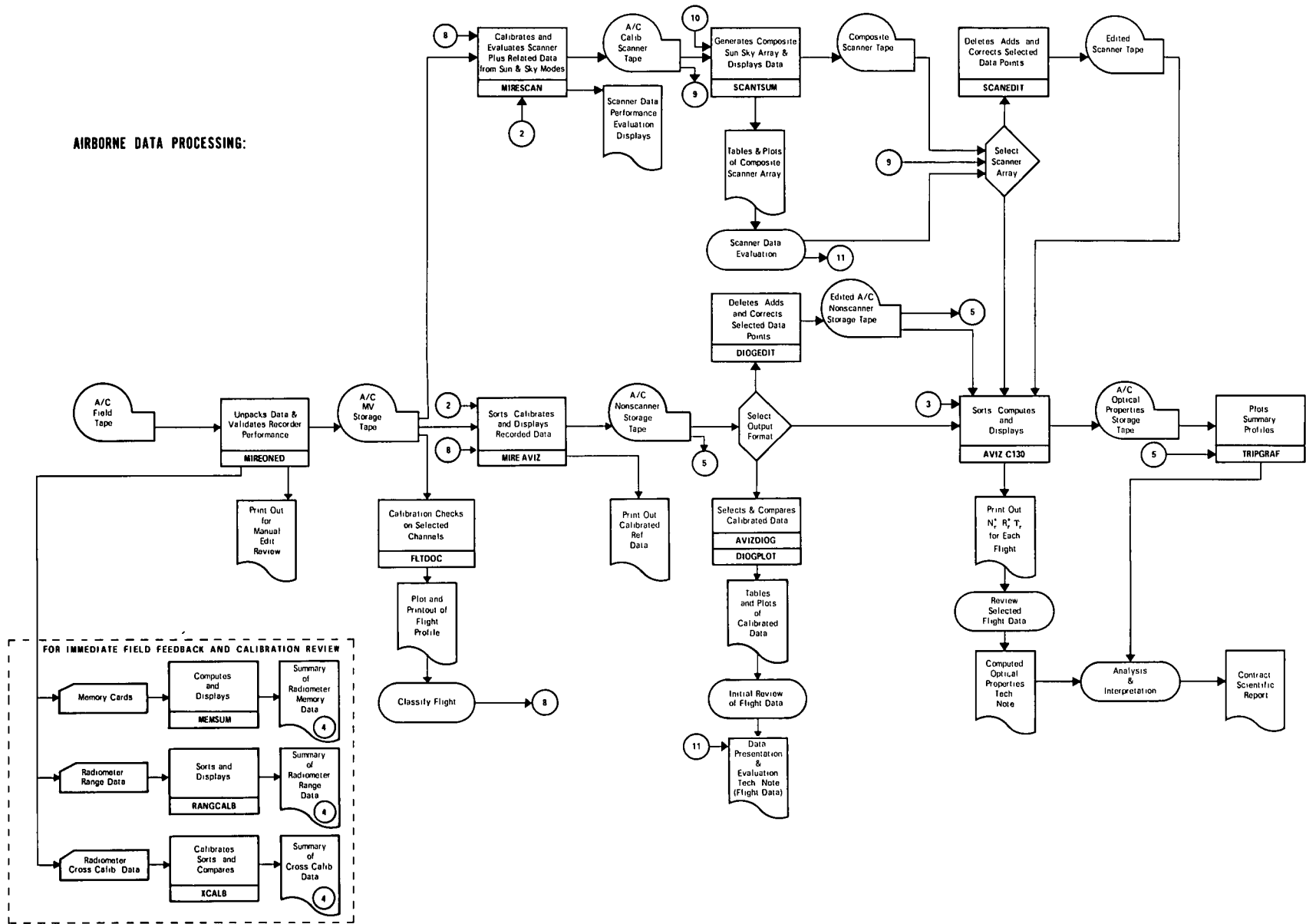
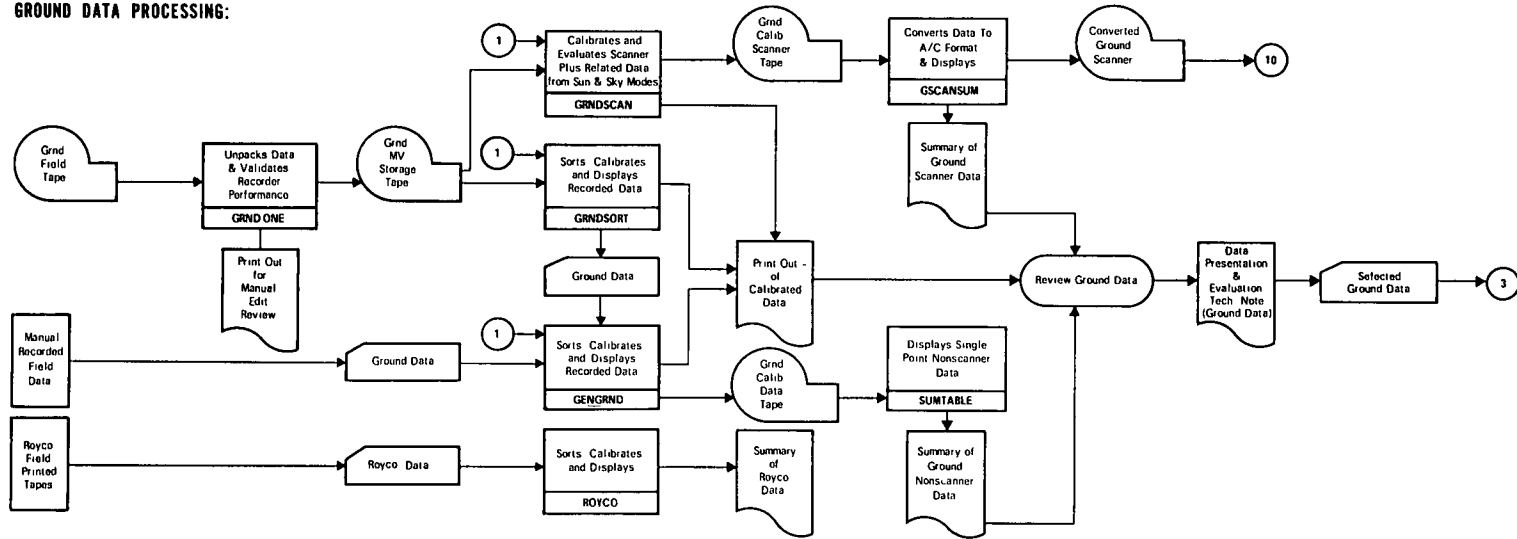

Fig. 5-1. Atmospheric Visibility Program Airborne Data Processing Schedule.

GROUND DATA PROCESSING:



CALIBRATION DATA PROCESSING:

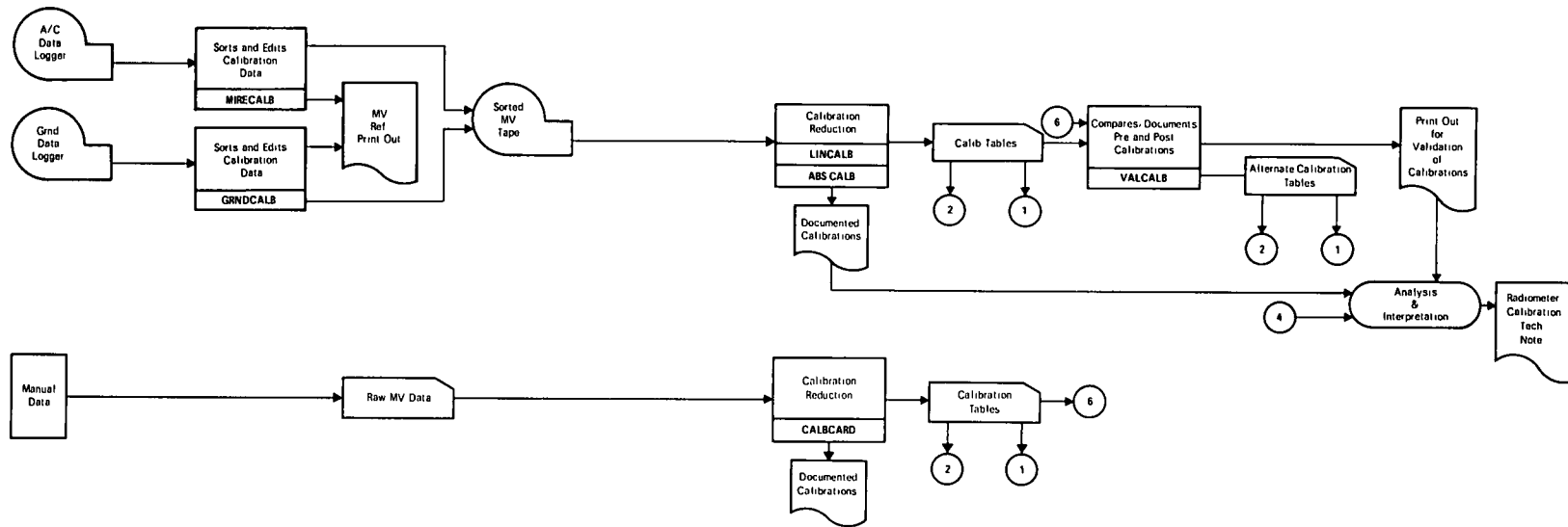

Fig. 5-2. Atmospheric Visibility Program Ground Data Processing Schedule.

5.2 GROUND-BASED DATA

Only the CRM system was used for the collection of ground-based data and its output was manually recorded. Due to the relatively small quantities of ground data acquired during OPAQUE II no automatic processing has been required.

5.3 CALIBRATION DATA

The calibration data are the heart of the data processing system in that any data processed are only as good as the calibrations applied to them. The pre- and post-deployment calibration data are recorded on tape in an effort to eliminate the human bias and are handled in a phased procedure similar to that used in the general data processing technique. The data can be recorded on either the airborne or the ground data logging system. In an initial procedure, these data go through Program MIRECALB or GRNDCALB, according to the recording system used, to verify the electrical quality of the radiometer data and associated monitored parameters. For final processing, the data are sorted and stored in set fashion.

The details of processing the calibration data according to the procedure illustrated in Fig. 5-2 are described in our preceding reports, AFCRL-72-0593, Duntley, *et al.* (1972c), AFCRL-TR-75-0457, Duntley, *et al.* (1975a) and AFCRL-TR-75-0414, Duntley, *et al.* (1975b), and will not therefore be discussed further herein.

5.4 DATA TAPES

The data processing sequences referenced in the previous paragraphs produce output tapes containing a broad catalog of calibrated data. These tapes are useable as data inputs to a multiplicity of diverse problems requiring a knowledge of atmospheric optical properties. To simplify future retrieval, the data tape numbers, the in-house descriptions of the data, and the computed properties reported herein have been summarized in Table 5.1.

Table 5.1

Processed Data Library Tapes

OPAQUE II Flight No.	DIOGEDIT Tape No. VL-363H File No.	Data Presentation No.	Computed Properties No.
C-390	1	142	143
C-391	2	142	143
C-392	3	142	143
C-393	4	142	143
C-394	5	142	143
C-395	6	142	143
C-397	8	142	143
C-398	9	142	143
C-399	10	142	143
C-400	11	142	143
C-401	12	142	143
C-402	13	142	143

6. WEATHER SUMMARY

6.1 INTRODUCTION AND GRAPHICS

Meteorological data available for analysis included daily surface and 500-millibar charts obtained from the Environmental Technical Applications Center (ETAC) at Scott Air Force Base. The surface and the 500-millibar charts were for 1200 GMT and covered the Northern Atlantic and western Europe. Northern hemisphere surface charts for 1200 GMT prepared by the National Oceanographic Atmospheric Administration were obtained from the National Climatic Center in Asheville. Portions of these charts have been reproduced as Fig. 6-1. The approximate flight track locations were indicated in Fig. 6-1 with the symbol ★. Also utilized were radiosonde data from locations near each of the flight tracks, and tabular data for the hourly observations from nearby weather stations.

Section 6.2 includes a discussion of the surface and 500-millibar charts for each flight. Tabular data for stations near each flight track are presented in Section 6.3.

The measurements of temperature taken on the aircraft, and the computed relative humidity are presented in Figs. 6-2 and 6-3. The temperatures were measured continuously by an AN/AMQ-17 aerograph system described briefly in AFCRL-70-0137, Duntley, *et al.* (1970a) and more completely in USNAF TP-133. The corresponding dewpoint/frostpoint temperatures were measured using a Cambridge 137-C3 Aircraft Hygrometer System which is described briefly in AFCRL-72-0593, Duntley, *et al.* (1972c). Unfortunately a faulty amplifier in this system interposed intermittent spurious signals on the dewpoint temperature data. The deletion of data points affected by this fault has resulted in several apparent anomalies in the computed relative humidity plots, particularly on those plots representing Flights C-398, C-400, and C-401. More detailed comment related to this problem is presented in Section 8.1. Dewpoint temperature was not measured during Flight C-402 due to the failure of the CAM-137 system.

The profile identification symbols used in Figs. 6-2 and 6-3 are related to the spectral filter sequence during which the data were measured, i.e., the temperature profile identified with the Filter 2 symbol was taken during the same time interval as the Filter 2 radiometric measurements, the temperatures coded as Filter 3 were taken simultaneously with the Filter 3 radiometric measurements, etc. Table 6.1, abstracted from program FLTDOC listings, summarizes the beginning and ending times associated with each flight element during which these meteorological and radiometric measurements were made. The time separations between profiles are substantial and should be carefully considered when assessing the temporal stability of the subject airmass.

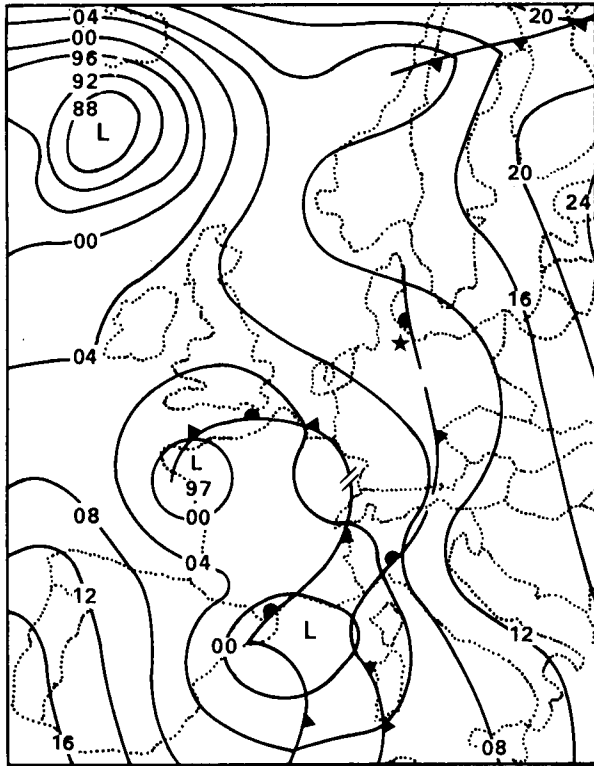

25 OCTOBER 1976 1200 GMT

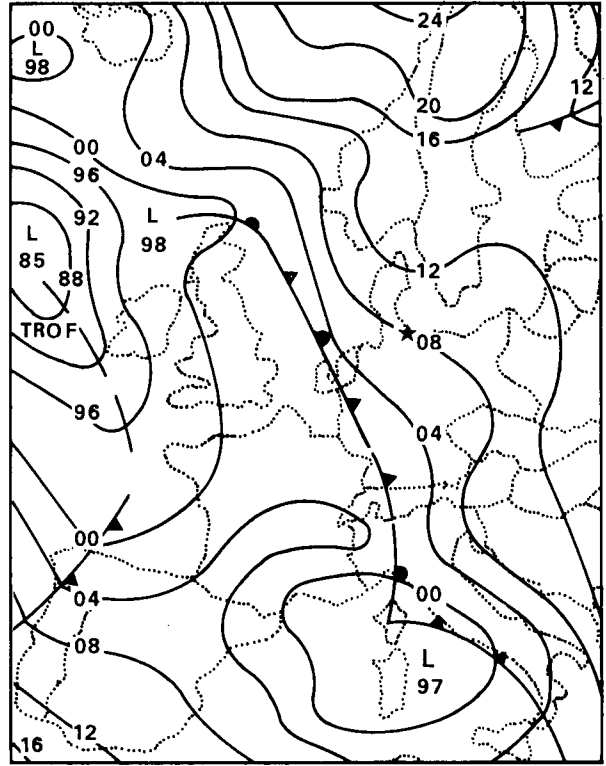

26 OCTOBER 1976 1200 GMT

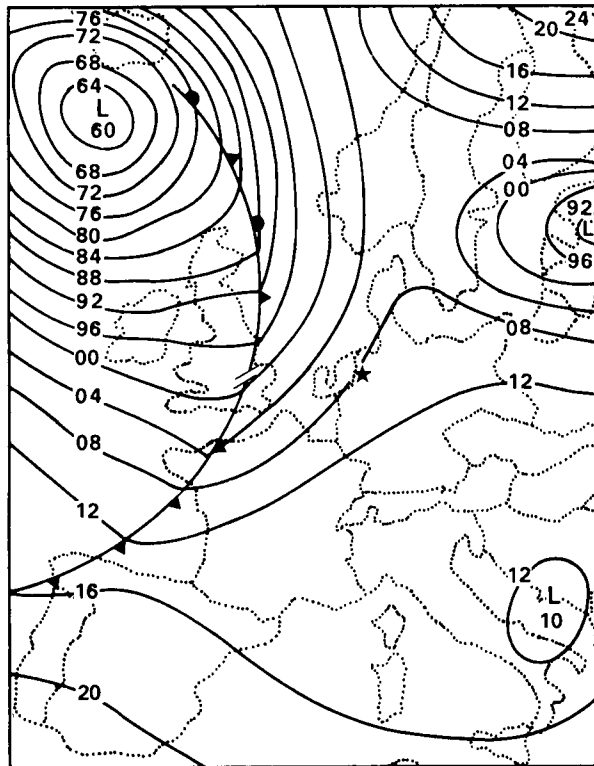

1 NOVEMBER 1976 1200 GMT

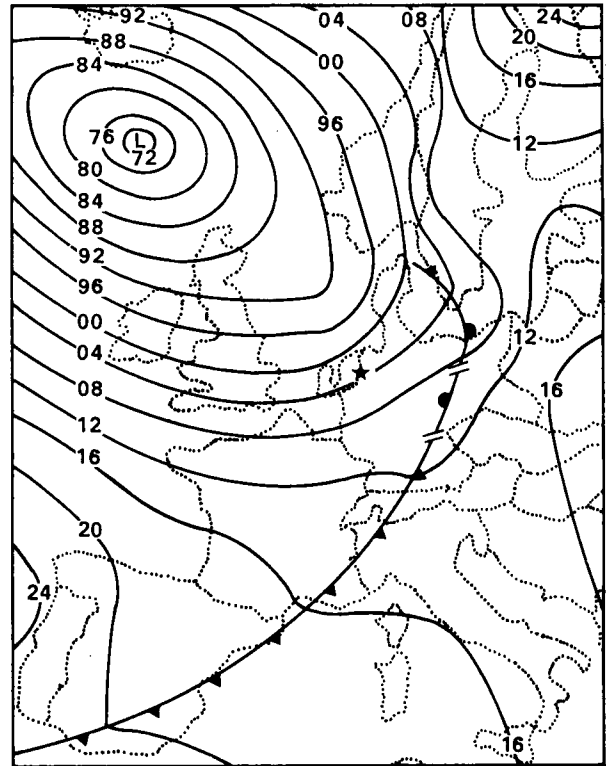

2 NOVEMBER 1976 1200 GMT

Fig. 6-1. Synoptic Charts of European Area During Project OPAQUE II.

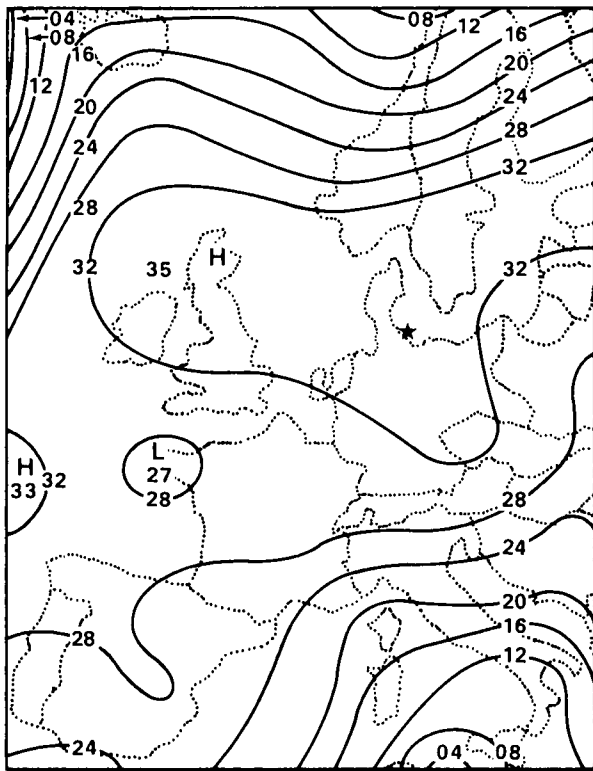

18 NOVEMBER 1976 1200 GMT

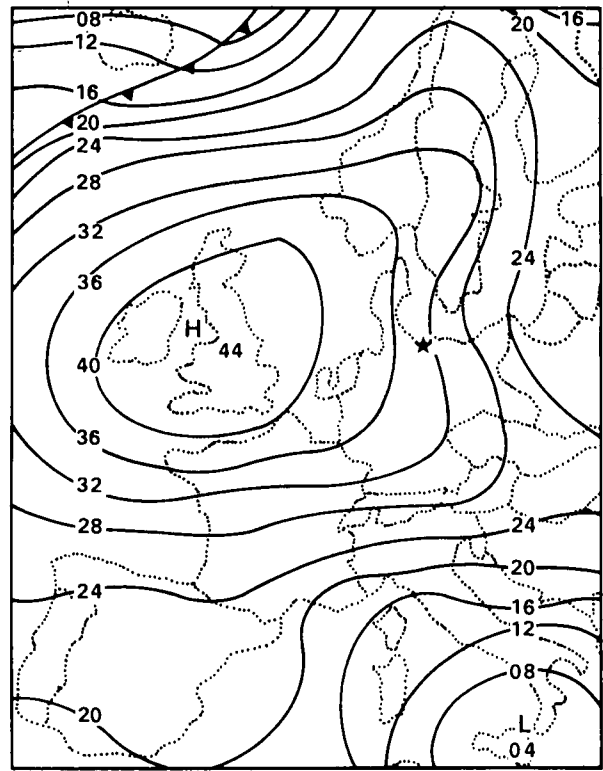

19 NOVEMBER 1976 1200 GMT

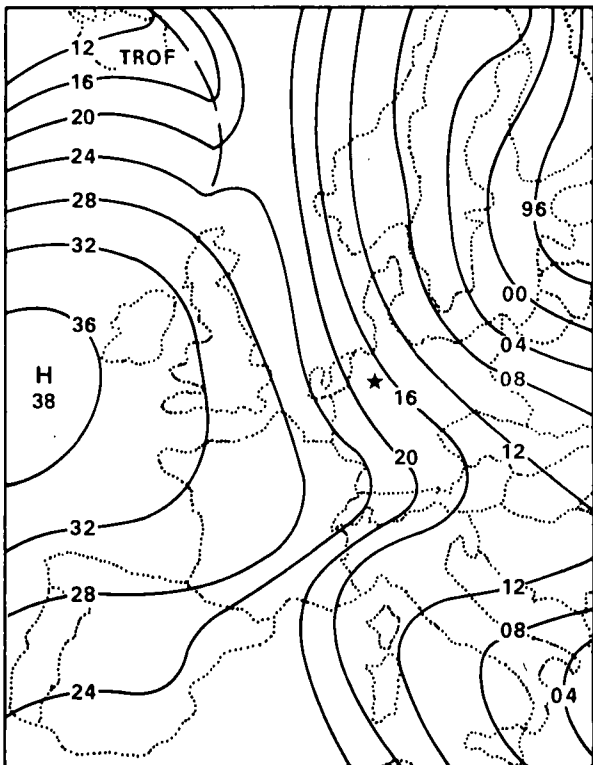

23 NOVEMBER 1976 1200 GMT

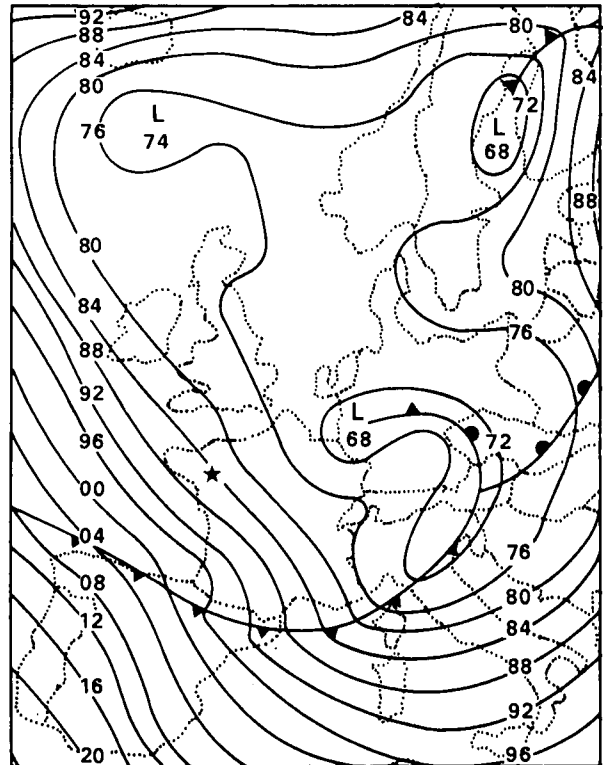

2 DECEMBER 1976 1200 GMT

Fig. 6-1 cont. Synoptic Charts of European Area During Project OPAQUE II.

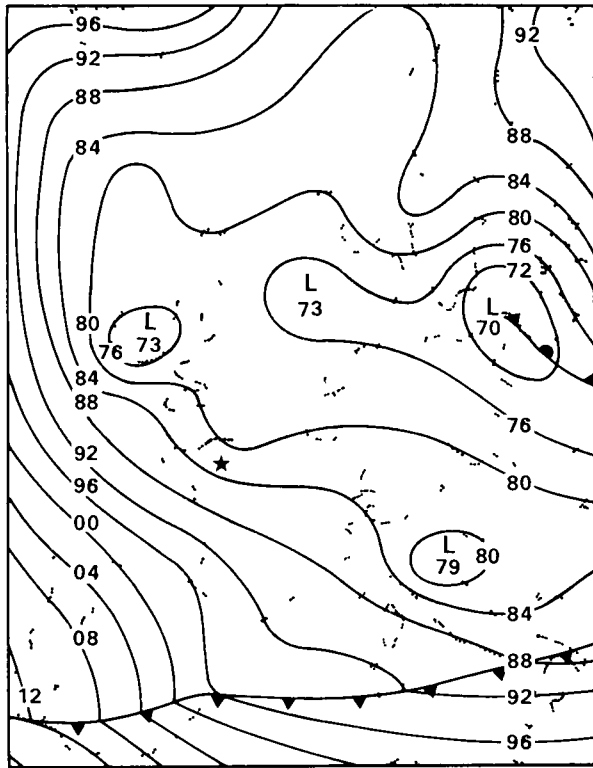

3 DECEMBER 1976 1200 GMT

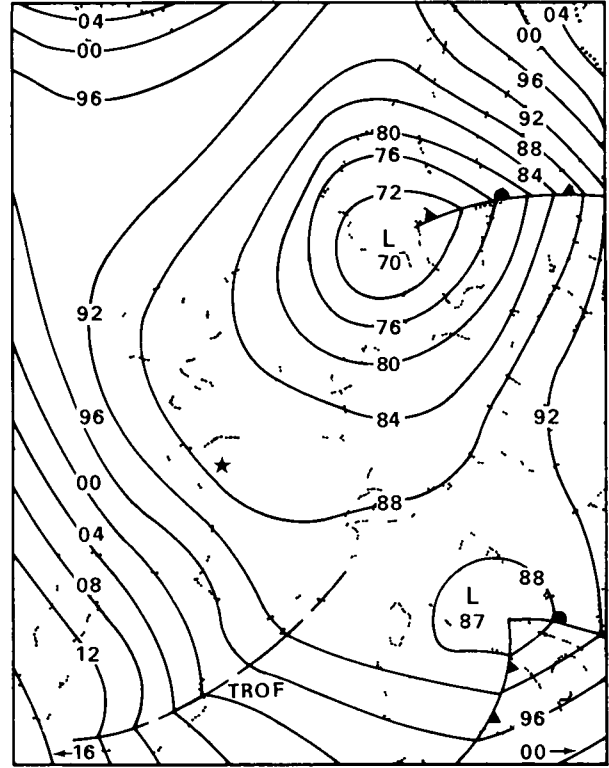

4 DECEMBER 1976 1200 GMT

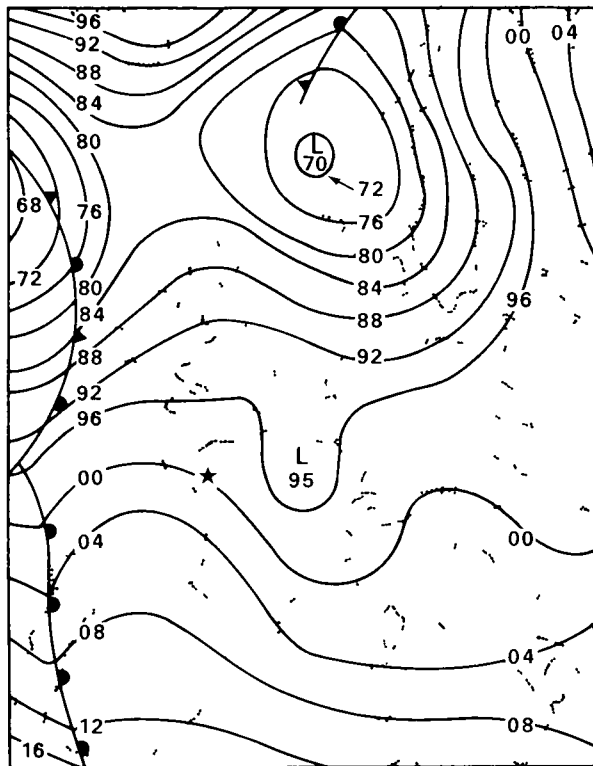

5 DECEMBER 1976 1200 GMT

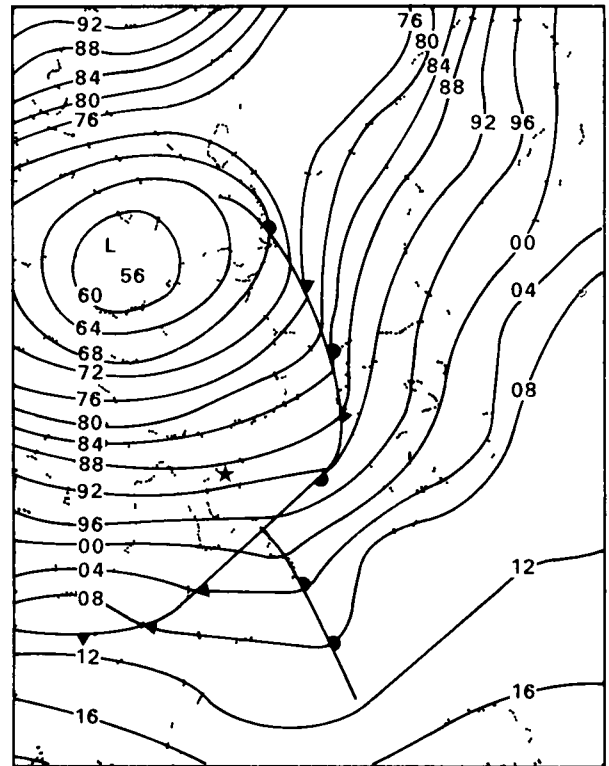

6 DECEMBER 1976 1200 GMT

Fig 6-1 cont Synoptic Charts of European Area During Project OPAQUE II

FLIGHT C-390

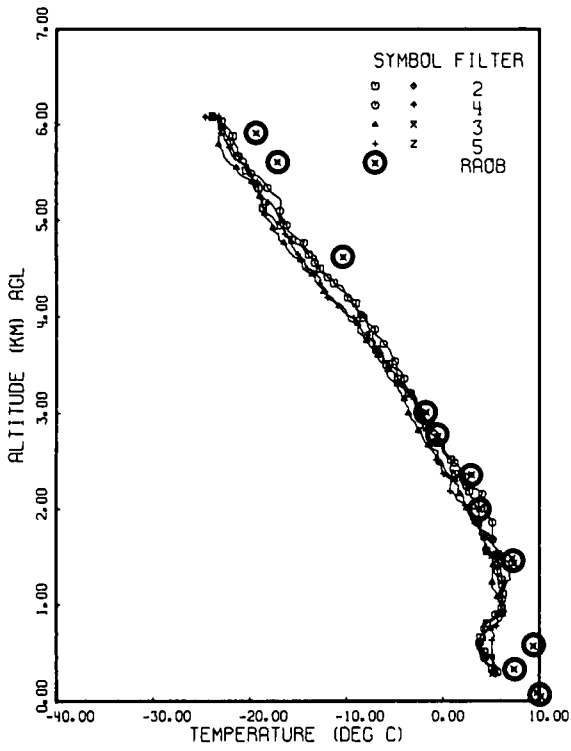

FLIGHT C-391

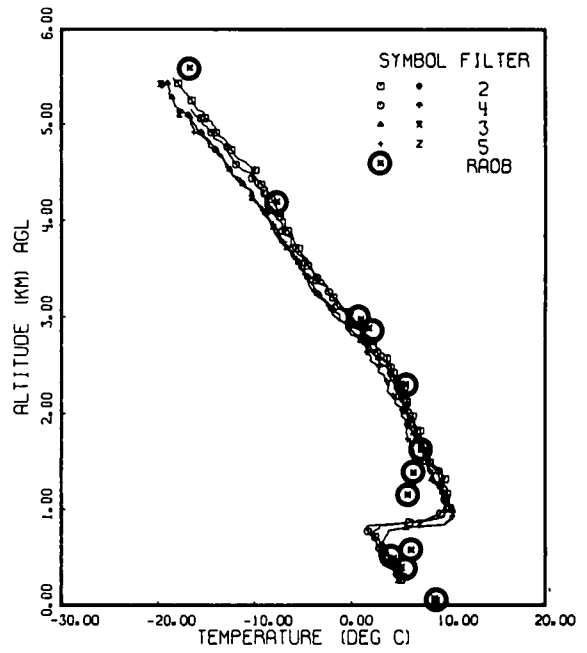

FLIGHT C-392

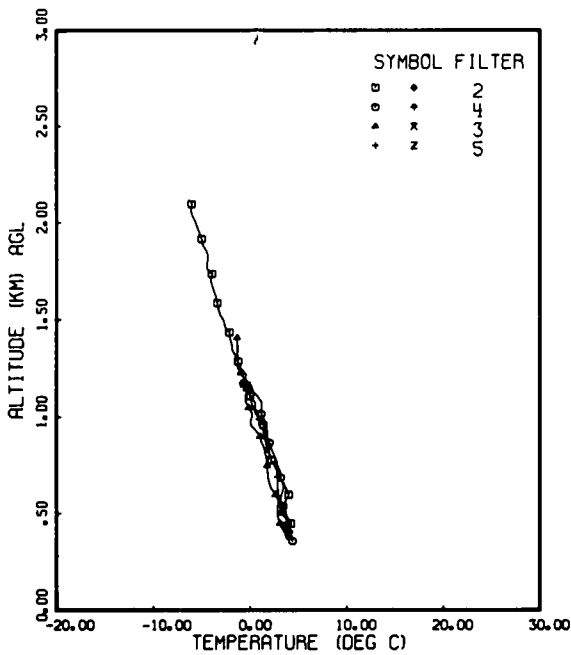

FLIGHT C-393

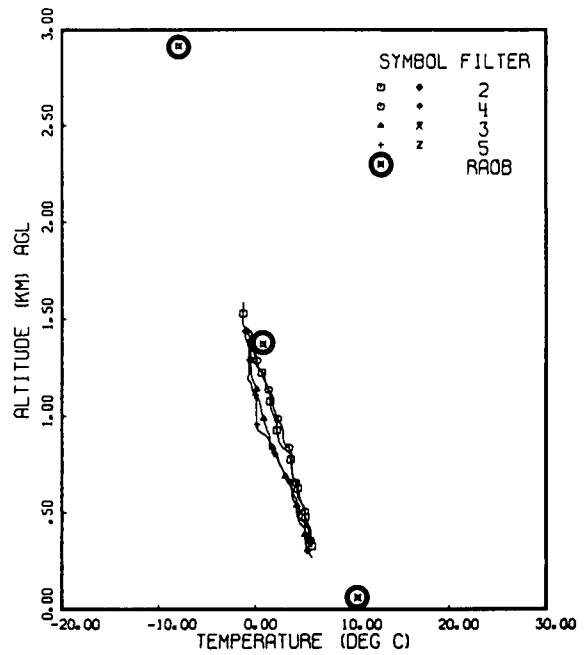
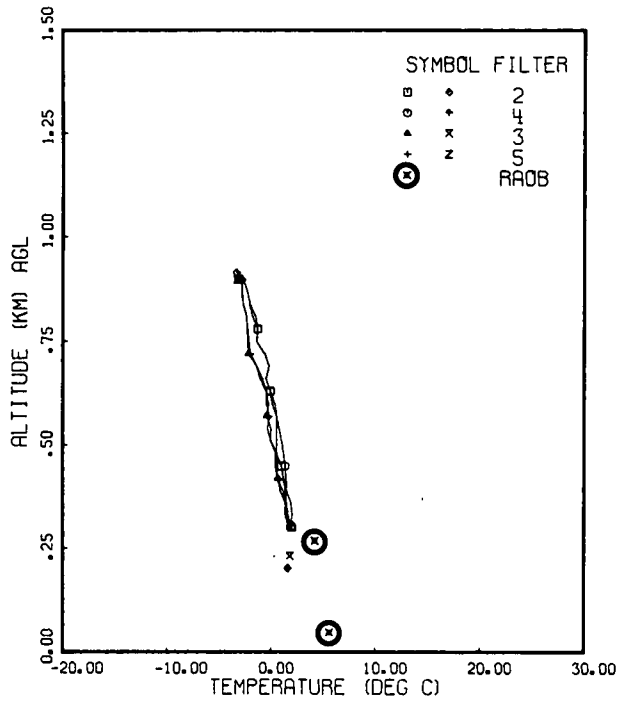
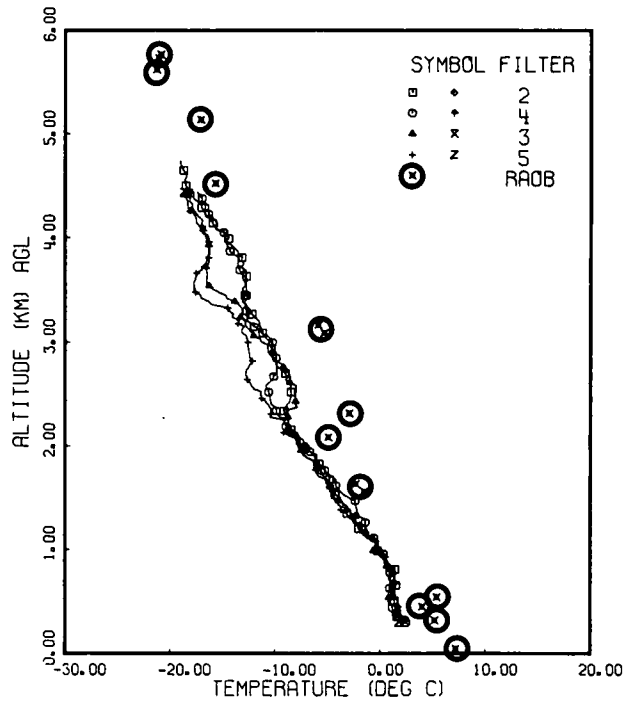

Fig. 6-2. Temperature Versus Altitude for Twelve Project OPAQUE II Flights.

FLIGHT C-394



FLIGHT C-395



FLIGHT C-397

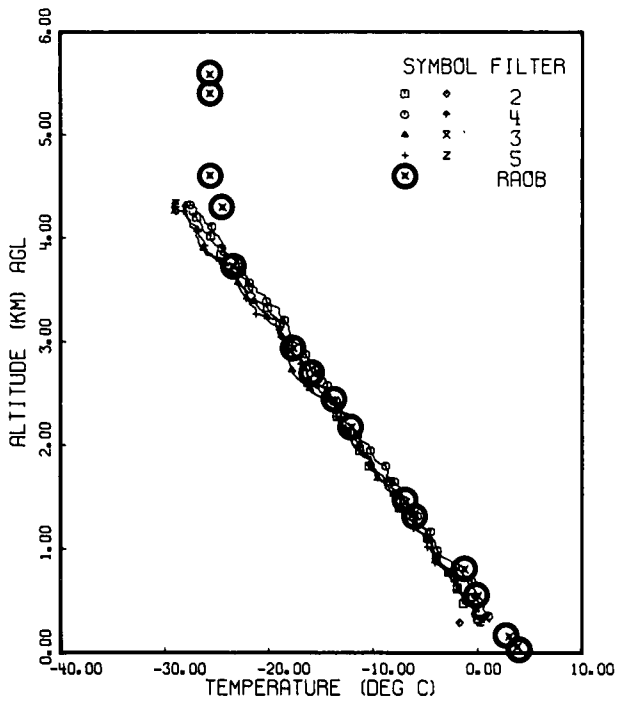

FLIGHT C-398

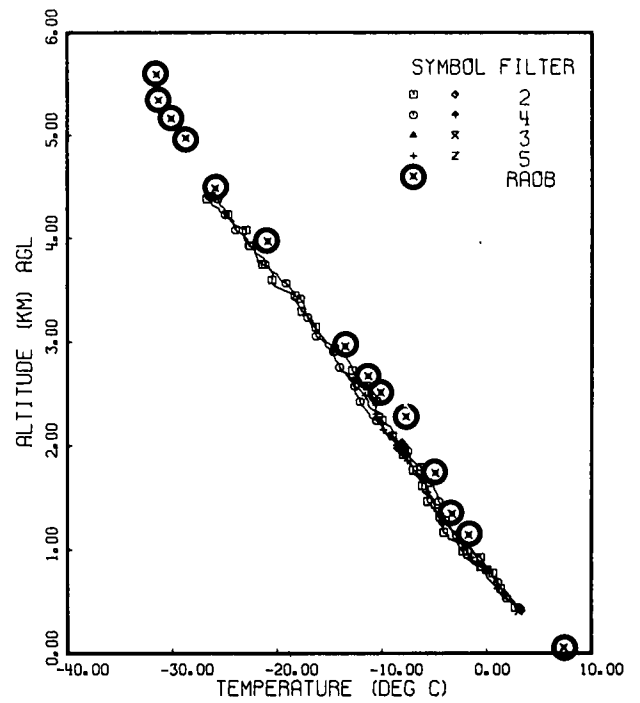
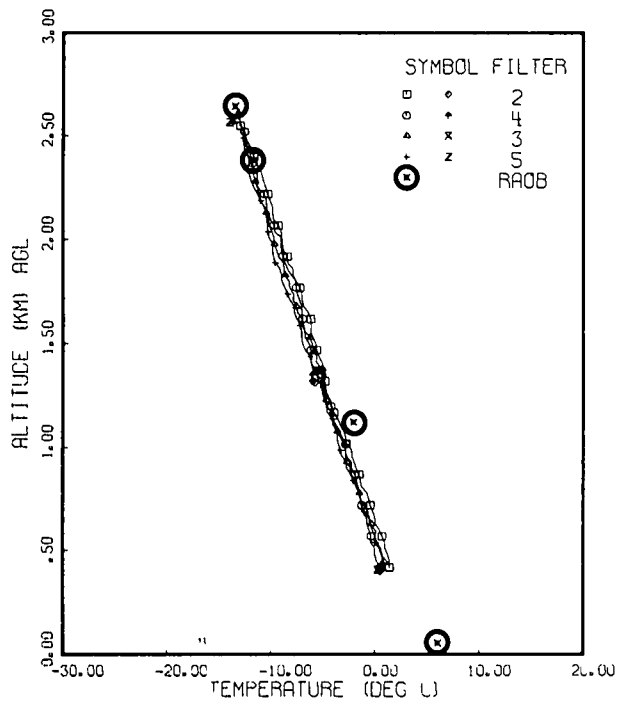
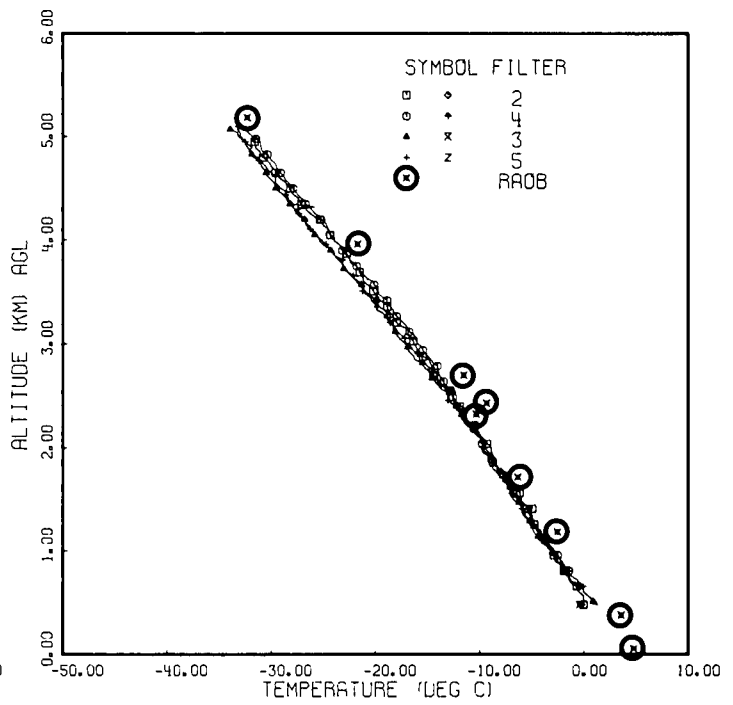

Fig. 6-2 cont. Temperature Versus Altitude for Twelve Project OPAQUE II Flights.

FLIGHT C-399



FLIGHT C-400



FLIGHT C-401

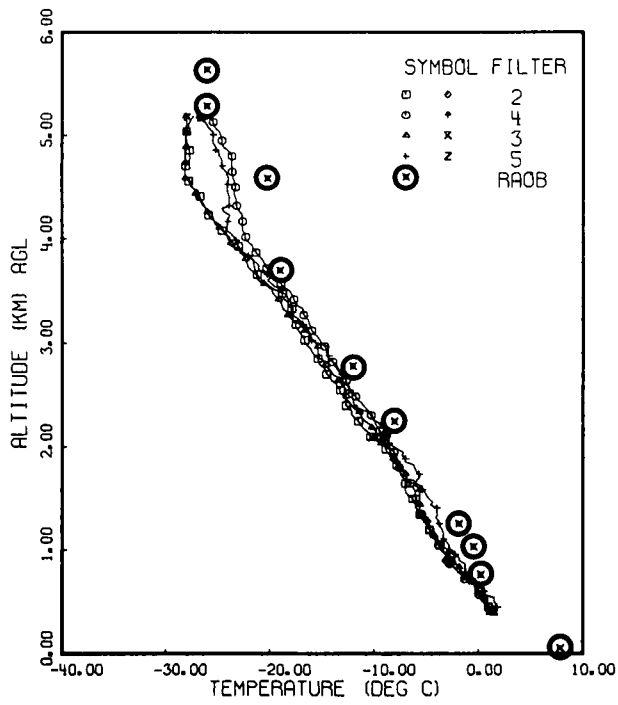

FLIGHT C-402

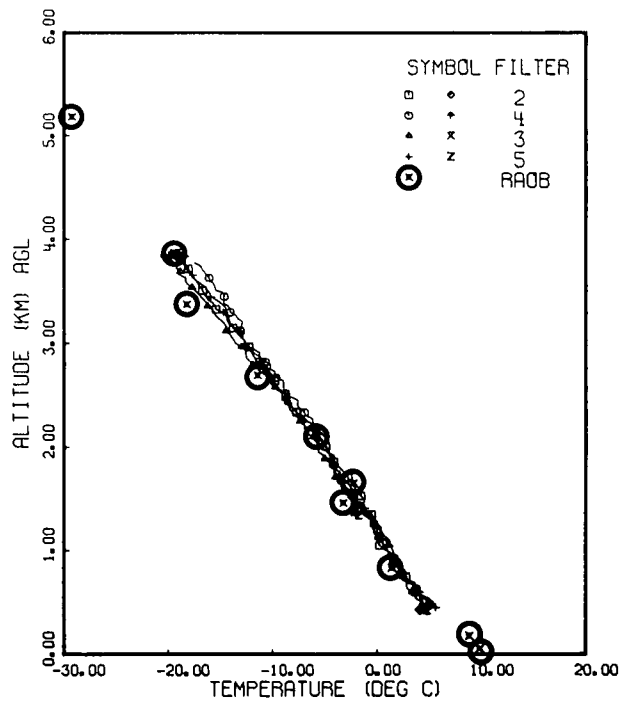
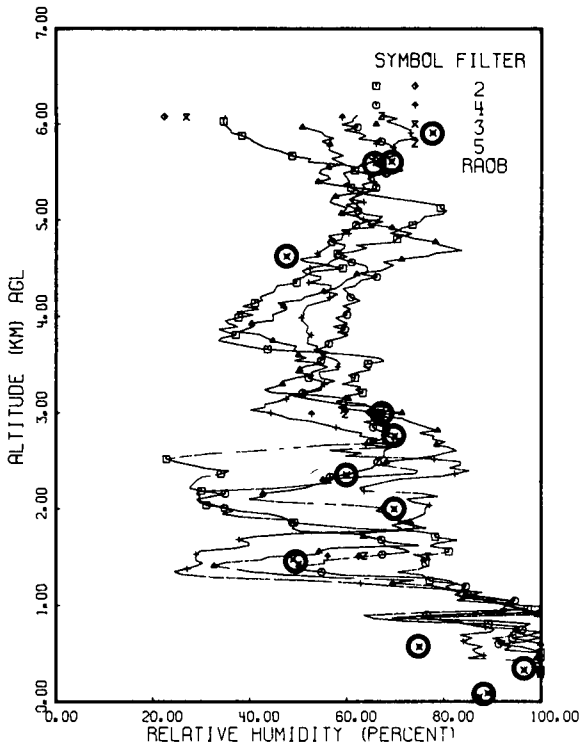
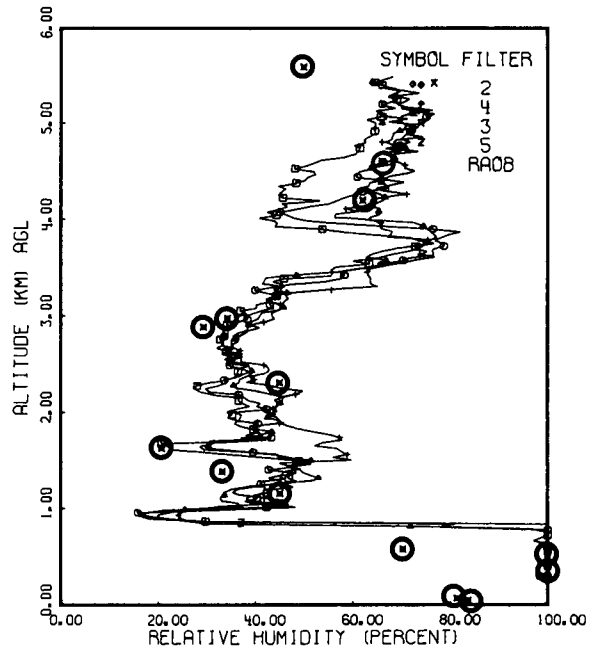

Fig. 6-2 cont. Temperature Versus Altitude for Twelve Project OPAQUE II Flights.

FLIGHT C-390



FLIGHT C-391



FLIGHT C-392

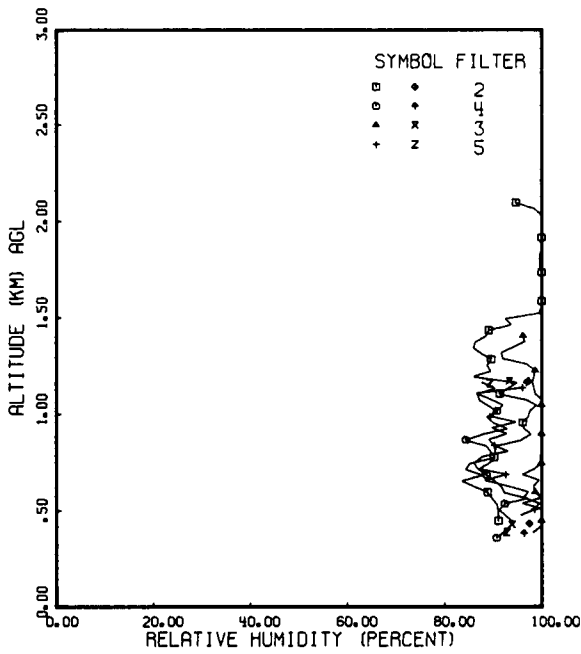

FLIGHT C-393

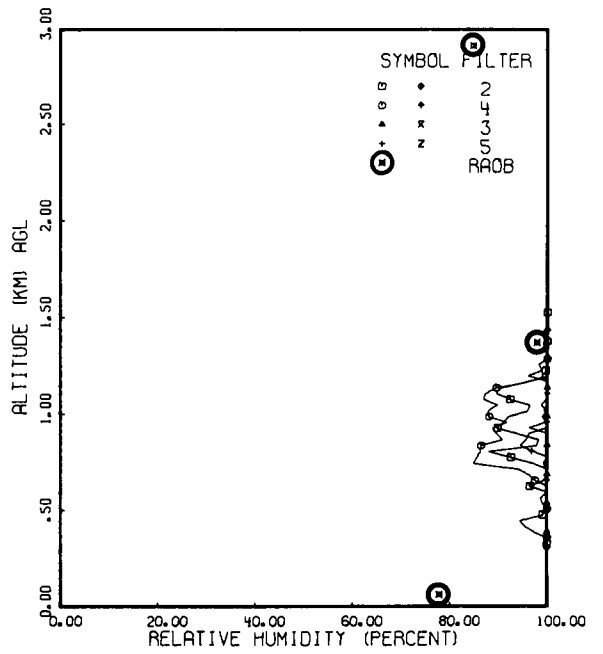
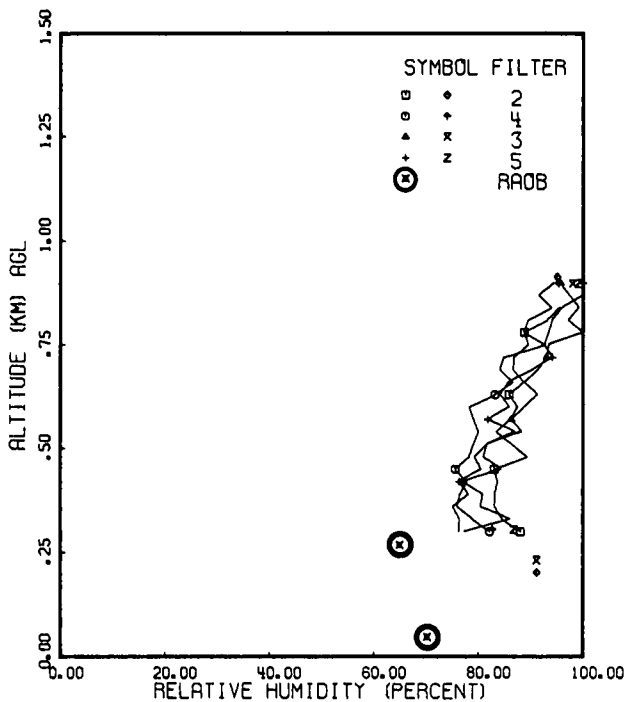
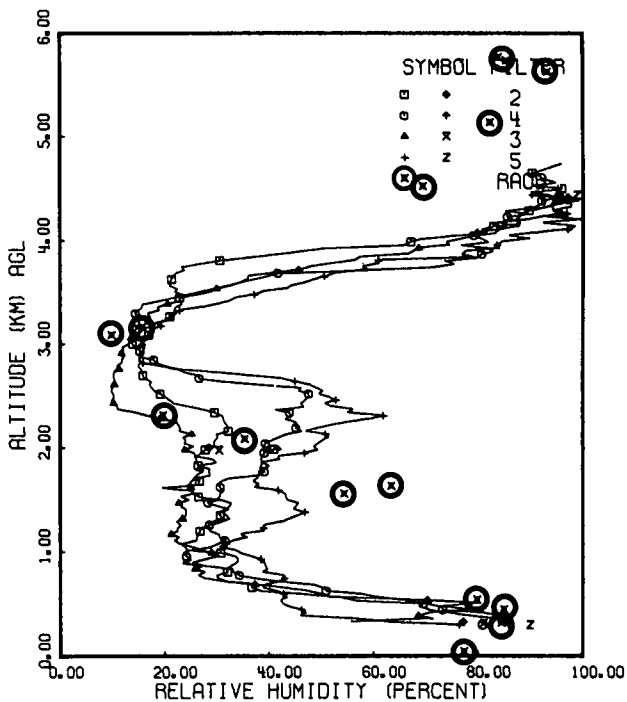

Fig. 6-3. Relative Humidity Versus Altitude for Eleven Project OPAQUE II Flights.

FLIGHT C-394



FLIGHT C-395



FLIGHT C-397

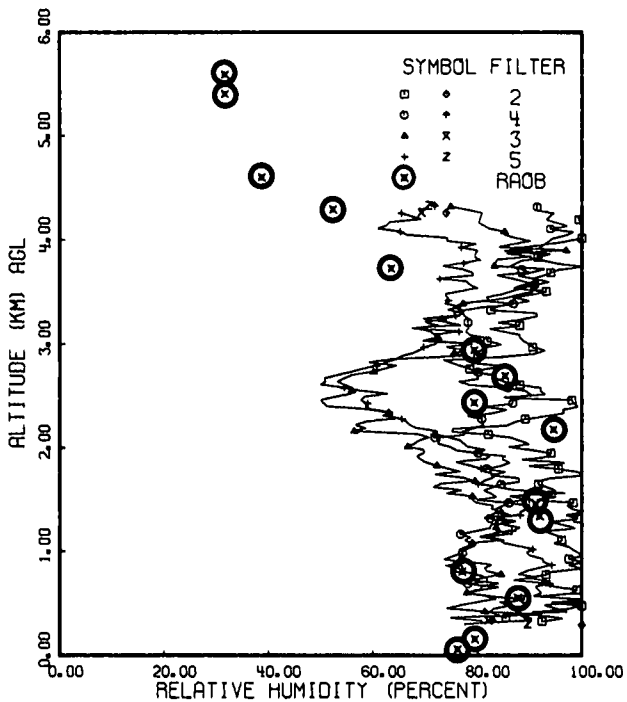

FLIGHT C-398

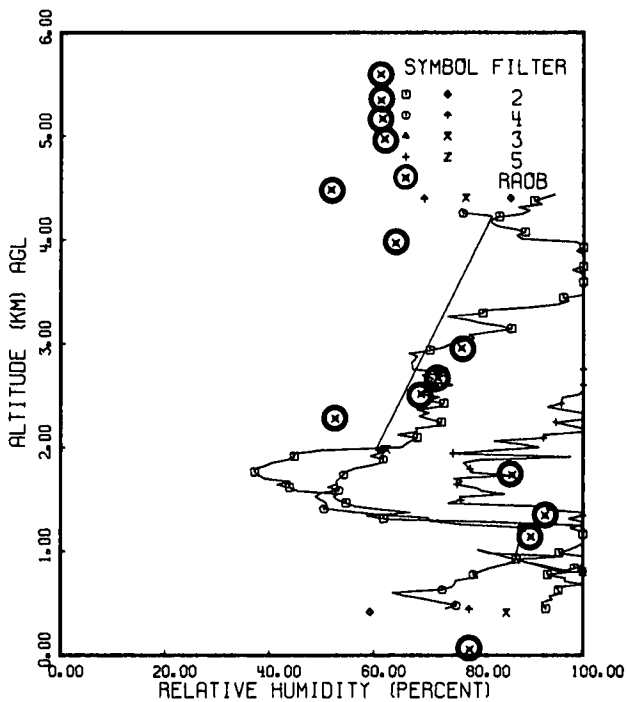
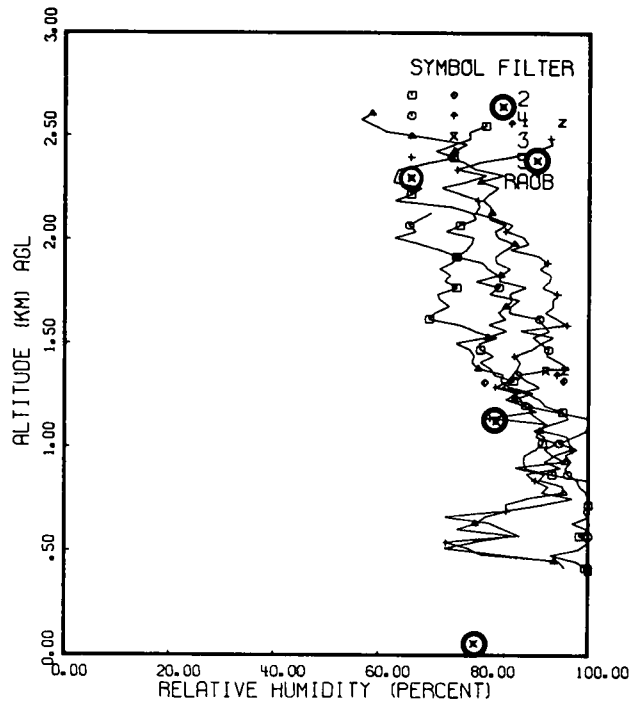
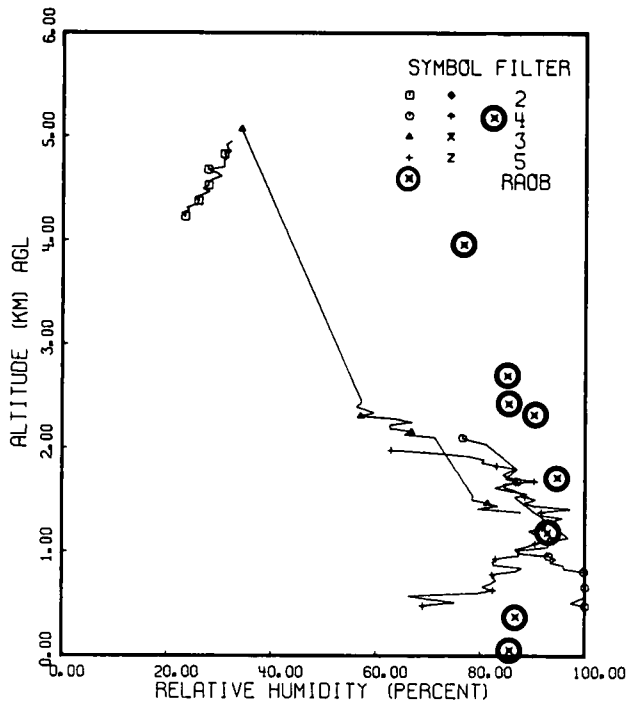

Fig. 6-3 cont. Relative Humidity Versus Altitude for Eleven Project OPAQUE II Flights.

FLIGHT C-399



FLIGHT C-400



FLIGHT C-401

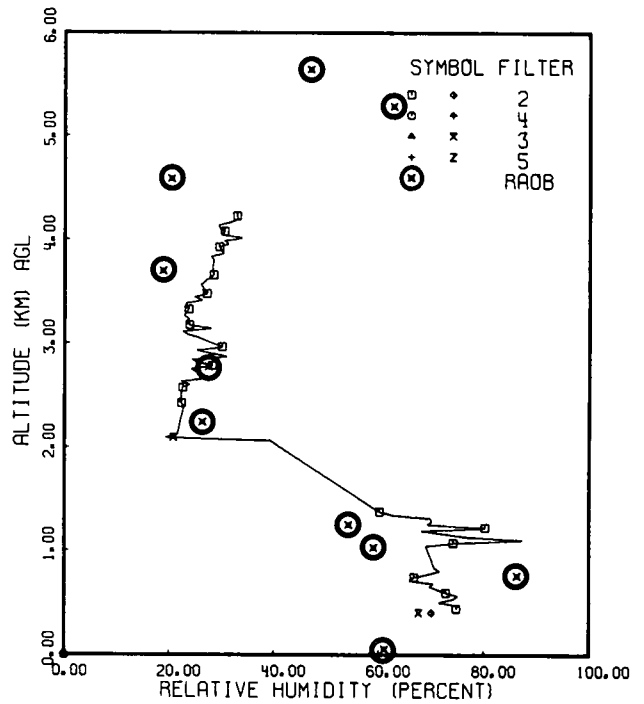

Fig. 6-3 cont. Relative Humidity Versus Altitude for Eleven Project OPAQUE II Flights.

Radiosonde observations for 1200 GMT were available from sites near each of the flight tracks except for Flight C-392 on 1 November 1976. The temperatures from the radiosonde station closest to each flight track have been plotted on the temperature plots in Fig. 6-2. The relative humidities, computed from RAOB temperature and dewpoint depression measurements are shown on the plots in Fig. 6-3. The locations of the radiosonde stations are shown on the maps in Section 1. More detailed location information as well as the station identification code used in Figs. 6-2 and 6-3 is included in Table 6.2. Although the RAOB data are graphed with the C-130 data, it should be remembered that the two data sets are often remote in either space or time. The geographical separations are also noted in the flight descriptions in Section 7.3, and the time separations may be determined by comparing the flight times noted in Tables 6.1 and 7.3 with the RAOB time of 1200 GMT.

During each of the flights except C-391 an on-board meteorologist made and recorded observations concerning the cloud and haze conditions, shadows, visibility of the solar disc, and slant path visibilities from various altitudes. Some of these observations are included in the tables in Section 6.3 and the flight descriptions in Section 7.3. These in-flight observations have been very useful in evaluating and confirming the data recorded by the airborne instrument systems.

Table 6.1

Flight Profile Elapsed Time Summary

Flight No.	1976 Date	Profile Flight Times (GMT)								Total Time Elapsed (V-Pro Only)	
		Filter 2		Filter 4		Filter 3		Filter 5		Hours	Minutes
		Start	Stop	Start	Stop	Start	Stop	Start	Stop		
C-390	25 Oct	1246	1353	1443	1543	1411	1425	1602	1615	3	29
C-391	26 Oct	1122	1140	1215	1232	1151	1206	1241	1253	1	31
C-392	1 Nov	1128	1200	1224	1227	1206	1208	1251	1253	1	25
C-393	2 Nov	1042	1046	1108	1111	1050	1053	1114	1117	0	35
C-394	18 Nov	1157	1159	1235	1239	1218	1221	1255	1259	1	02
C-395	19 Nov	1150	1226	1321	1354	1243	1253	1411	1422	2	32
C-397	23 Nov	1206	1217	1240	1252	1222	1233	1302	1317	1	11
C-398	2 Dec	1155	1257	1321	1359	—	—	1415	1420	2	25
C-399	3 Dec	1234	1241	1129	1202	1245	1250	1225	1230	1	21
C-400	4 Dec	1115	1132	1219	1233	1146	1204	1250	1305	1	50
C-401	5 Dec	1052	1154	1247	1355	1212	1227	1414	1428	3	36
C-402	6 Dec	1213	1249	1337	1410	1308	1318	1435	1445	2	32

6.2 SYNOPTIC CONDITIONS

FLIGHT C-390 ON 25 OCTOBER 1976

The surface chart for 1200 GMT had a stationary front dissipating east of the flight area along the Göteborg-Schwerin-Schweinfurt line. Another stronger frontal system paralleled and followed 3 degrees west of this front. Widespread fog is shown in advance of both frontal regions. At 500 millibars a high was located over eastern Poland and a trough of low pressure over Great Britain. Moderate southwesterly flow was over the region. The airmass was stable maritime polar.

FLIGHT C-391 ON 26 OCTOBER 1976

The surface chart for 1200 GMT had an occluded front extending from a low centered at 58.5N 8.0W. This front extended east and southeast through the North Sea and central Netherlands then as a stationary front through western Germany and Switzerland. Stratus and ground fog are prevalent in advance of the system. At 500 millibars a high was centered over southern Sweden with light southerly winds over Denmark. The airmass was stable maritime polar.

FLIGHT C-392 ON 1 NOVEMBER 1976

The surface chart for 1200 GMT had a weak ridge with its axis through eastern Germany. From a 960-millibar low centered south of Iceland an occlusion extended east and southsoutheast through the western part of the North Sea then as a cold front south and southsouthwest through western France and northwestern Spain and Portugal into the Atlantic. At 500 millibars there was a low over western Finland. A weak gradient prevailed over western Europe with light to moderate westerly winds. The airmass was stable maritime polar.

Table 6.2

Radiosonde Station Identification

Flight Nos.	Track Identification	Radiosonde Station	Range and Direction from Track Center	Figs. 6-2 and 6-3 Identification Code
C-390, C-391	Rodby	Schleswig	106 km W	RAOB S
C-392, C-393	Meppen	Rheine/Waldhufe	81 km S	RAOB R
C-394, C-395	Rodby	Schleswig	106 km W	RAOB S
C-397	Meppen	Rheine/Waldhufe	81 km S	RAOB R
C-398, C-399, C-400, C-401, C-402	Bruz	Brest	200 km WNW	RAOB B

FLIGHT C-393 ON 2 NOVEMBER 1976

On the 1200 GMT surface chart a 972-millibar low southeast of Iceland was filling and moving slowly eastward. A rapidly moving occlusion was along the Göteborg-Szczelin-Bayreuth-Turin-Cordoba line and southwesterly to the Atlantic. A trough line paralleled the front from the North Sea to the Haarlem-Gent-Paris line. At 500 millibars there was weak ridging over Poland and troughing over Ireland with moderate westsouthwesterly flow. The airmass was unstable maritime polar.

FLIGHT C-394 ON 18 NOVEMBER 1976

At 1200 GMT the surface chart showed a high centered over Scotland that covered Britain and the Scandinavian peninsula. Widespread ground fog and cumulus with stratocumulus were charted over Scandinavia and eastern Europe. There was also a filling low in Sicily with a cold front extending into Libya. At 500 millibars there was a low over eastern Poland with a weak gradient over western Europe. Light to moderate northwest to north flow was over the flight region. The airmass was stable maritime polar.

FLIGHT C-395 ON 19 NOVEMBER 1976

The surface chart for 1200 GMT had a 1044-millibar high centered in the Irish Sea which had strengthened in the past 24 hours and was dominating all of Europe. At 500 millibars there was a trough from Finland through Latvia and a high moving from the Atlantic towards Ireland. Moderate to strong northerly flow was over the region of the flight. The airmass was unstable maritime polar.

FLIGHT C-397 ON 23 NOVEMBER 1976

The surface chart for 1200 GMT showed that a secondary low had formed near Leningrad with a pressure of 992 millibars. From this low a cold front extended south and southwest to another low centered near Athens. This low was partially blocking the 1038-millibar high located at 49N 16W from moving into Ireland and was shunting it towards France. At 500 millibars there was a trough over eastern Latvia with ridging west of Ireland that produced moderate to strong northwesterly flow. The airmass was unstable maritime polar.

FLIGHT C-398 ON 2 DECEMBER 1976

The surface chart for 1200 GMT had an extensive frontal system over Europe with a 970-millibar low centered near Cologne. The cold front portion of this system extended from western Austria southwest to northwestern Italy and west through the northernmost parts of Spain. This deep low system in conjunction with a 1035-millibar high located at 34N 32W produced a strong surface pressure gradient with resulting strong winds. At 500 millibars there was a low off Bergen, Norway with a trough extending southward to Sardinia. The flow over the region of the flight was strong northwesterly. The airmass was unstable maritime polar.

FLIGHT C-399 ON 3 DECEMBER 1976

The surface chart for 1200 GMT had a complex low over Europe and the eastern Atlantic with a

973-millibar low over Ireland and another in the North Sea. A cold front, part of this system, extended from the Black Sea through the heel of Italy then westsouthwest to southern Spain then southwest into the Atlantic. At 500 millibars there was a low in the North Sea with the trough axis southeast to Romania. Moderate westerly flow was over the flight area. The airmass was unstable maritime polar.

FLIGHT C-400 ON 4 DECEMBER 1976

At 1200 GMT the surface chart had a 970-millibar low centered between Norway and Denmark with a frontal system southeast into Russia. A secondary low of 987 millibars was centered in the Adriatic and had a cold front extending southwest into Algeria. A trough extended from Marseille to Valencia and Gibraltar. Another deepening storm center with accompanying fronts caused all of the area north of 40N to be affected by low pressures. At 500 millibars there was a low over Denmark with a trough southsouthwestward to Algeria. There was moderate westnorthwest flow over the flight region. The airmass was unstable maritime polar.

FLIGHT C-401 ON 5 DECEMBER 1976

The surface chart for 1200 GMT showed that a complex low dominated northern Europe and the northern Atlantic. A 960-millibar low had an occlusion oriented 4 degrees west of the Irish coast and 8 degrees from western France. There was an open 995-millibar low located near Paris. Some weak ridging between the two lows occurred over the area of Rennes. At 500 millibars there was a low north of Bergen together with weak ridging off France and into southeastern Ireland and Great Britain. This pressure combination produced moderate northwesterly flow over the flight region. The airmass was unstable maritime polar.

FLIGHT C-402 ON 6 DECEMBER 1976

The surface chart for 1200 GMT had an extensive storm with a 956-millibar low at 56N 12W and a 970-millibar low at 52N 31W. An occlusion that had passed through France was now along a line through the North Sea-Luxemburg-Bordeaux then as a cold front into the Atlantic. At 500 millibars there was a low off northern Ireland associated with the surface low that produced a strong westsouthwesterly gradient and winds over western Europe. The airmass was unstable maritime polar.

6.3 TABULAR SUMMARY AND GLOSSARY

A summary of the daily meteorological observations taken at the weather stations nearest each flight track on the days during which data flights were made is presented in Table 6.3. A glossary of the most often used symbols is also included. All data were reported in Greenwich Civil Time.(GCT) which is equivalent to Greenwich Mean Time (GMT), which is the terminology used in Table 6.1.

METEOROLOGICAL GLOSSARY AND ABBREVIATIONS

<p style="text-align: center;">SKY AND CEILING</p> <p>Sky cover symbols are in ascending order. Figures preceding symbols are heights in hundreds of feet above station. Sky cover symbols are:</p> <ul style="list-style-type: none"> ○ Clear: less than 0.1 sky cover ⊙ Scattered: 0.1 to less than 0.6 sky cover ⊖ Broken: 0.6 to 0.9 sky cover ⊕ Overcast: more than 0.9 sky cover <li style="padding-left: 20px;">- Thin (when prefixed); light (when suffixed) <li style="padding-left: 20px;">-- Very light (when suffixed) <li style="padding-left: 20px;">-X Partial obscuration: 0.1 to less than 1.0 sky hidden by precipitation or obstruction to vision (bases at surface) <li style="padding-left: 20px;">X Obscuration: 1.0 sky hidden by precipitation or obstruction to vision (bases at surface) <p>Letter preceding height of layer identifies ceiling layer and indicates how ceiling height was obtained. Thus:</p> <ul style="list-style-type: none"> A Aircraft B Balloon (pilot or ceiling) D Estimated height of cirriform clouds on basis of persistency E Estimated height of noncirriform clouds M Measured R Radiosonde balloon or radar U Height of cirriform ceiling layer unknown V Immediately following numerical value indicates a varying ceiling (also used with varying visibility) W Indefinite, sky obscured by surface base phenomenon. e.g. fog, blowing dust, snow 	<p style="text-align: center;">VISIBILITY (VV)</p> <p>Reported in kilometers.</p> <hr/> <p style="text-align: center;">WEATHER AND OBSTRUCTION TO VISION SYMBOLS</p> <table style="width: 100%; border: none;"> <tr> <td style="width: 50%;">A Hail</td> <td style="width: 50%;">IF Ice fog</td> </tr> <tr> <td>AP Small hail</td> <td>K Smoke</td> </tr> <tr> <td>BD Blowing dust</td> <td>L Drizzle</td> </tr> <tr> <td>BN Blowing sand</td> <td>R Rain</td> </tr> <tr> <td>BS Blowing snow</td> <td>RW Rain showers</td> </tr> <tr> <td>D Dust</td> <td>S Snow</td> </tr> <tr> <td>E Sleet</td> <td>SG Snow grains</td> </tr> <tr> <td>EW Sleet showers</td> <td>SP Snow pellets</td> </tr> <tr> <td>F Fog</td> <td>SW Snow showers</td> </tr> <tr> <td>GF Ground fog</td> <td>T Thunderstorms</td> </tr> <tr> <td>H Haze</td> <td>ZL Freezing drizzle</td> </tr> <tr> <td>IC Ice crystals</td> <td>ZR Freezing rain</td> </tr> </table> <hr/> <p style="text-align: center;">CLOUD ABBREVIATIONS</p> <table style="width: 100%; border: none;"> <tr> <td style="width: 50%;">Ac Altocumulus</td> <td style="width: 50%;">Cs Cirrostratus</td> </tr> <tr> <td>As Altostratus</td> <td>Cu Cumulus</td> </tr> <tr> <td>Cb Cumulonimbus</td> <td>Ns Nimbostratus</td> </tr> <tr> <td>Cc Cirrocumulus</td> <td>Sc Stratocumulus</td> </tr> <tr> <td>Ci Cirrus</td> <td>St Stratus</td> </tr> </table> <hr/> <p style="text-align: center;">WIND</p> <p>Direction in ten's of degrees from true north, speed in meters per second (mps). A "0000" indicates calm. A "G" indicates gusty. A "Q" indicates squall. Peak speed of gusts, when reported, follows G or Q. The contraction WSHFT in remarks followed by time group (GMT) indicates wind shift and its time of occurrence.</p> <p style="text-align: center;">Examples: 0109 is 010 degrees, 9 mps. 3607G11 is 360 degrees, 7 mps, peak speed in gusts of 11 mps.</p>	A Hail	IF Ice fog	AP Small hail	K Smoke	BD Blowing dust	L Drizzle	BN Blowing sand	R Rain	BS Blowing snow	RW Rain showers	D Dust	S Snow	E Sleet	SG Snow grains	EW Sleet showers	SP Snow pellets	F Fog	SW Snow showers	GF Ground fog	T Thunderstorms	H Haze	ZL Freezing drizzle	IC Ice crystals	ZR Freezing rain	Ac Altocumulus	Cs Cirrostratus	As Altostratus	Cu Cumulus	Cb Cumulonimbus	Ns Nimbostratus	Cc Cirrocumulus	Sc Stratocumulus	Ci Cirrus	St Stratus
A Hail	IF Ice fog																																		
AP Small hail	K Smoke																																		
BD Blowing dust	L Drizzle																																		
BN Blowing sand	R Rain																																		
BS Blowing snow	RW Rain showers																																		
D Dust	S Snow																																		
E Sleet	SG Snow grains																																		
EW Sleet showers	SP Snow pellets																																		
F Fog	SW Snow showers																																		
GF Ground fog	T Thunderstorms																																		
H Haze	ZL Freezing drizzle																																		
IC Ice crystals	ZR Freezing rain																																		
Ac Altocumulus	Cs Cirrostratus																																		
As Altostratus	Cu Cumulus																																		
Cb Cumulonimbus	Ns Nimbostratus																																		
Cc Cirrocumulus	Sc Stratocumulus																																		
Ci Cirrus	St Stratus																																		
<p style="text-align: center;">RELATIVE HUMIDITY (RH)</p> <p>Reported in percent and computed from temperature and dewpoint.</p>																																			

Table 6.3

STANDARD METEOROLOGICAL DATA SHEET

Flight No C-390
Date 25 October 1976

Field Site Rodby Track
Lat 54 41 N - Long 11 08 E - El 0m

Time GMT	Sky and Ceiling (Hundreds of Feet)	Visibility (Kilometers)	Weather and Obstructions To Vision	Temp (°C)	Dewpoint (°C)	Wind		Remarks Remarks
						Direction (00 - 36)	Speed (mps)	
KEGNAES (06119) 54°51'N 10°0'E Elev 23m West of Track								
1200	E 9 ⊕	2.4	F-	9.0	8.0	MSG		8/8 St
1500	E 12 ⊕ 120 ⊕	2.6	F-	9.0	8.0	12	3.1	5/8 St 4/8 Ac
FEHMARNBELT (10006) 54°57'N 12°34'E Elev 4m South of Track Center								
1200	○	4.0	F-	10.0	7.0	11	1.5	
1500	250 ⊕	4.0	F-	MSG	MSG	09	4.1	2/8 Ci
MON (06179) 54°57'N 12°34'E Elev 15m Northeast of Track								
1200	E 20 ⊕	5.0	F-	MSG	MSG	09	1.0	8/8 Sc
1500	E 20 ⊕	5.0	F-	MSG	MSG	09	1.0	8/8 Sc
HAMBURG (10147) 53°38'N 10°0'E Elev 16m Southwest of Track								
1020	MSG	3.0	F-	10.0	8.0	09	1.0	
1120	MSG	3.0	F-	11.0	7.0	12	2.0	
1200	E230 ⊕	3.0	F-	11.0	7.0	11	2.6	5/8 Ci
1220	230 ⊕	5.0	H	12.0	6.0	11	3.0	4/8 Ci
1500	E250 ⊕	4.5	GF	11.0	7.0	09	2.1	5/8 Ci
1520	E250 ⊕	3.0	GF	10.0	6.0	08	3.0	6/8 Ci
1620	E250 ⊕	2.8	GF	9.0	6.0	07	2.5	6/8 Ci

Table 6.3 (cont.)

STANDARD METEOROLOGICAL DATA SHEET

Flight No C-391
Date 26 October 1976

Field Site Rodby Track
Lat 54°41'N – Long 11°08'E – El 0m

Time GMT	Sky and Ceiling (Hundreds of Feet)	Visibility (Kilometers)	Weather and Obstructions To Vision	Temp (°C)	Dewpoint (°C)	Direction (00–36)	Speed (mps)	Remarks
KEGNAES (06119) 54°51'N 10°0'E Elev 23m								West of Track
0900	E 18 ⊕	4.5	F–	9.0	7.0	11	9.3	8/8 St
1200	E 16 ⊕	3.0	F–	9.0	7.0	08	9.3	8/8 Sc
1500	E 14 ⊕	4.0	F–	9.0	7.0	11	12.4	8/8 Sc
FEHMARNBELT (10006) 54°36'N 11°09'E Elev 4m								South of Track Center
0900	E 7 ☉	4.0	F–	8.0	7.0	11	9.3	7/8 Cu & Sc
1200	E 15 ☉	2.0	F–	9.0	7.0	11	9.3	5/8 Cu & Sc
1500	E 15 ⊕	4.0	F–	10.0	7.0	11	9.3	8/8 Sc
MON (06179) 54°57'N 12°34'E Elev 15m								Northeast of Track
0900	E 5 ⊕	6.0	F–	MSG	–	09	4.1	8/8 St
1200	E 2 ⊕	6.0	F–	MSG	–	07	6.2	8/8 St
1500	E 2 ⊕	6.0	F–	MSG	–	07	8.2	8/8 St
HAMBURG (10147) 53°38'N 10°0'E Elev 16m								Southwest of Track
1020	E 3 ⊕	3.0	F–	5.0	4.0	08	4.6	8/8 St
1120	E 5 ⊕	3.0	F–	6.0	5.0	09	5.6	8/8 St
1200	E 8 ⊕	3.5	F–	6.0	5.0	10	5.1	8/8 St
1320	10 ☉	2.5	F–	8.0	6.0	10	5.1	3/8 Sc
1420	250–☉	3.0	F–	7.0	6.0	09	4.6	2/8 Ci
1500	250–☉	3.0	F–	7.0	6.0	09	4.1	3/8 Ci

Table 6.3 (cont.)

STANDARD METEOROLOGICAL DATA SHEET

Flight No. C-392
1 November 1976Field Site: Meppen Track
Lat. 53°00' N – Long. 7°38' E – El. 18 m

Time GMT	Sky and Ceiling (Hundreds of Feet)	Visibility (Kilometers)	Weather and Obstructions To Vision	Temp. (°C)	Dewpoint (°C)	Direction (00–36)	Speed (mps)	Remarks
EELDE (06280) 53°08' N 6°36' E Elev. 5m								Northwest of Track
1000	80 ☉ 200 ☉	7.0	H	7.0	5.0	17	4.1	1/8 Ac 3/8 Ci
1100	E 10 ☉ 80 ☉ 200 ☉	6.0	H	8.0	6.0	19	5.7	6/8 St 7/8 Ac 7/8 Ci
1200	10 ☉ E 90 ☉	8.0	H	9.0	6.0	18	4.6	1/8 St 7/8 Ac
1225	E 13 ☉	5.0	H	9.0	6.0	18	6.1	5/8 St
1300	E 15 ☉	6.0	H	9.0	5.0	18	6.7	8/8 St
1325	E 90 ☉	6.0	RW-	9.0	6.0	18	6.1	5/8 Ac
1400	10 ☉ E 90 ☉	5.0	RW-	9.0	5.0	18	6.2	3/8 Sc 5/8 Ac
1500	E 28 ☉ 90 ☉	4.6	R-	9.0	6.0	18	5.1	5/8 Sc 7/8 Ac
1600	E 15 ☉ 90 ☉	4.5	R-			17	5.7	5/8 Sc 7/8 Ac
LINGEN (10305) 52°31' N 7°20' E Elev. 21 m								South of Track
1000	40 ☉ E 90 ☉	4.2	F-	8.0	5.0	19	4.1	2/8 Sc 5/8 Ac
1100	E 40 ☉ 90 ☉	7.0	H	9.0	4.0	20	5.1	5/8 Sc 6/8 Ac
1200	15 ☉ E 100 ☉	7.0	H	10.0	5.0	21	5.7	3/8 Cu & Sc 5/8 Ac
1300	15 ☉ E 90 ☉	8.0		10.0	5.0	21	4.1	3/8 Cu & Sc 5/8 Ac
1400	15 ☉ E 90 ☉	8.0		10.0	5.0	21	5.6	2/8 Cu & Sc 5/8 Ac
1500	E 25 ☉ 90 ☉	10.0		10.0	5.0	22	6.7	5/8 Sc 8/8 Ac
TWENTE (06290) 52°16' N 6°55' E Elev. 35 m								West of Track
1000	50 ☉ E 80 ☉	6.0	H	8.0	5.0	20	6.2	1/8 Sc 7/8 Ac
1100	50 ☉ E 80 ☉	7.0	H	8.0	5.0	20	6.2	1/8 Sc 7/8 Ac
1200	25 ☉ E 120 ☉ 250 ☉	8.0	H	9.0	5.0	21	6.7	1/8 Sc 5/8 Ac 2/8 Ci
1229	E 21 ☉ 120 ☉ 250 ☉	8.0	H	9.0	5.0	20	7.2	6/8 Sc 7/8 Ac 7/8 Ci
1300	E 20 ☉ 120 ☉	8.0	H	9.0	6.0	20	6.7	7/8 Sc 8/8 Ac
1400	E 18 ☉ 90 ☉	7.0	R-	9.0	6.0	20	7.2	7/8 Sc 8/8 Ac

Table 6.3 (cont.)

STANDARD METEOROLOGICAL DATA SHEET

Flight No C-393
Date 2 November 1976

Field Site Meppen Track
Lat 53°00'N – Long 7°38'E – El 18 m

Time GMT	Sky and Ceiling (Hundreds of Feet)	Visibility (Kilometers)	Weather and Obstructions To Vision	Temp (°C)	Dewpoint (°C)	Wind		Remarks
						Direction (00 – 36)	Speed (mps)	
EELDE (06280) 53°08'N 6°36'E Elev 5m Northwest of Track								
0900	15 ☉ E 35 ☉ 200 ☉	6.0	H	9.0	7.0	17	6.2	3/8 Cu & Sc 6/8 Ac 6/8 Ci
1000	15 ☉ E 100 ☉ 200 ☉	8.0	H	9.0	7.0	18	7.7	2/8 Cu & Sc 5/8 Ac 7/8 Ci
1025	E 40 ☉ 80 ☉ 200 ☉	9.0	H	10.0	8.0	19	8.2	4/8 Cu & Sc 6/8 Ac 7/8 Ci
1100	E 30 ☉ 80 ☉ 200 ☉	10.0		10.0	8.0	20	8.8	4/8 Cu & Sc 6/8 Ac 7/8 Ci
1200	E 25 ☉	4.5	R-	10.0	8.0	22	7.7	8/8 Cu & Sc
1300	E 40 ☉ 80 ☉ 200 ☉	5.0	RW-	9.0	8.0	22	6.2	5/8 Cb 6/8 Ac 7/8 Ci
LINGEN (10305) 54°31'N 7°20'E Elev 21m South of Track								
0900	E 15 ☉	12.0		10.0	7.0	21	5.1	6/8 Cu
1000	E 20 ☉	18.0		12.0	9.0	20	5.1	6/8 Cu
1100	E 38 ☉	18.0		11.0	7.0	22	7.2	6/8 Cu
1200	35 ☉ E 110 ☉	18.0	R-	11.0	6.0	22	7.2	4/8 Cu & Sc 7/8 Ac
1300	35 ☉ E 60 ☉	20.0	R-	11.0	6.0	22	6.6	4/8 Cu & Sc 6/8 Ac
TWENTE (06290) 52°16'N 6°55'E Elev 35m West of Track								
0900	8 ☉ 120-☉	8.0	F-	10.0	8.0	20	6.7	3/8 Cu & Sc 6/8 Ac
1000	15 ☉ 120-☉	10.0	F-	10.0	7.0	21	7.2	4/8 Cu 7/8 Ac
1100	15 ☉ 120-☉	10.0	R-	10.0	7.0	22	7.2	4/8 Cu & Sc 8/8 Ac
1200	15 ☉ E 90 ☉	10.0	R-	10.0	8.0	20	5.7	4/8 Cu & Sc 7/8 Ac

Table 6.3 (cont.)

STANDARD METEOROLOGICAL DATA SHEET

Flight No. C-394
Date: 18 November 1976

Field Site: Rodby Track
Lat. 54°41' N – Long. 11°08' E – El. 0 m

Time GMT	Sky and Ceiling (Hundreds of Feet)	Visibility (Kilometers)	Weather and Obstructions To Vision	Temp. (°C)	Dewpoint (°C)	Wind		Remarks
						Direction (00 – 36)	Speed (mps)	
KEGNAES (06119) 54°51' N 10°0' E Elev. 23 m								West of Track
0900	E 22 ☉	7.0	F-	6.0	3.0	20	3.1	8/8 Cu & Sc
1200	E 25 ☉	6.0	F-	6.0	2.0	23	2.1	8/8 Cu & Sc
1500	E200 ☉	8.0	F-	6.0	2.0	21	1.0	5/8 Ci
FEHMARNBELT (10006) 54°36' N 11°10' E Elev. 4 m								Southeast of Track
0900	E 33 ☉	20.0		7.0	2.0	00	00	8/8 Sc
1200	E 33 ☉	10.0		7.0	3.0	27	2.1	8/8 Sc
1500	E 33 ☉	10.0		6.0	3.0	34	3.1	8/8 Sc

Table 6.3 (cont.)

STANDARD METEOROLOGICAL DATA SHEET

Flight No. C-395
Date: 19 November 1976

Field Site: Rodby Track
Lat. 54°41'N – Long. 11°08'E – El. 0m

Time GMT	Sky and Ceiling (Hundreds of Feet)	Visibility (Kilometers)	Weather and Obstructions	Temp. (°C)	Dewpoint (°C)	Wind		Remarks
						Direction (00–36)	Speed (mps)	
KEGNAES (06119) 54°51'N 10°0'E Elev. 23m West of Track								
0900	250 ☉	8.0	F-	5.0	4.0	36	5.1	3/8 Cs
1200	180 ☉ 250- ☉	15.0		6.0	4.0	01	9.3	3/8 Ac 5/8 Ci
1500	180 ☉ 250- ☉	20.0		6.0	3.0	36	6.2	3/8 Ac 5/8 Cc
FEHMARNBELT (10006) 54°36'N 11°1'E Elev. 4m South of Track								
0900	E 18 ☉	10.0		6.0	5.0	34	6.2	8/8 Sc
1200	250-☉	10.0		7.0	4.0	01	10.8	2/8 Ci
1500	E 50 ☉	20.0		6.0	3.0	36	11.3	7/8 Sc
HAMBURG (10147) 53°38'N 10°0'E Elev. 16m Southwest of Track								
1200	E 12 ☉ 100 ☉	9.0		6.0	4.0	35	7.2	6/8 Sc 7/8 Ac
1220	12 ☉ 100-☉	8.0		7.0	4.0	35	8.2	2/8 Sc 7/8 Ac
1250	12 ☉ E 90 ☉	8.0		7.0	5.0	35	6.1	1/8 Cu 7/8 Ac
1350	12 ☉ 90 ☉	11.2		7.0	5.0	35	4.1	1/8 Cu 4/8 Ac
1500	12 ☉ E110 ☉ 200 ☉	20.0		7.0	3.0	36	5.7	1/8 Cu 5/8 Ac 7/8 Ci

Table 6.3 (cont.)

STANDARD METEOROLOGICAL DATA SHEET

Flight No. C-397
Date: 23 November 1976

Field Site: Meppen Track
Lat. 53°00' N – Long. 7°38' E – El. 18 m

Time GMT	Sky and Ceiling (Hundreds of Feet)	Visibility (Kilometers)	Weather and Obstructions To Vision	Temp. (°C)	Dewpoint (°C)	Wind		Remarks
						Direction (00–36)	Speed (mps)	
EELDE (06280) 53°81' N 6°36' E Elev. 5 m								Northwest of Track
1100	15 ☉ E220 ☉	40.0		5.0	1.0	30	7.2	4/8 Cb 5/8 Ci RW Distant
1200	15 ☉ E220 ☉	30.0		4.0	1.0	27	8.8	5/8 Cb 6/8 Ci RW Distant
1300	15 ☉ 220 ☉	30.0		4.0	1.0	29	4.1	3/8 Cb 4/8 Ci RW Distant
1400	15 ☉ E220 ☉	30.0		4.0	0.0	29	7.2	3/8 Cb 5/8 Ci
1500	15 ☉ E220 ☉	30.0		4.0	0.0	28	4.6	3/8 Cb 6/8 Ci
LINGEN (10305) 52°31' N 7°20' E Elev. 21 m								South of Track
1100	15 ☉	35.0		3.0	0.0	29	5.1	3/8
1200	MSG							
1300	15 ☉ E200 ☉	30.0		4.0	0.0	28	5.6	5/8 RW Distant
1400	15 ☉ E200 ☉	20.0		3.0	0.0	30	4.6	6/8 RW Distant
1500	15 ☉ E230 ☉	20.0		3.0	1.0	28	3.6	4/8 Cb 6/8 Cs RW Distant
OLDENBURG (10215) 53°18' N 8°18' E Elev. 12 m								East of Track
0944	E 15 ☉	11.2		1.0	1.0	27	4.6	RWE 0923
1044	E 15 ☉	6.0	RW	1.0	1.0	30	5.6	RWB 1000
1144	15 ☉	11.2		1.0	1.0	30	5.6	RW Distant
1244	15 ☉	7.0	F-	4.0	2.0	29	5.1	
1344	E 15 ☉	8.0		3.0	2.0	36	3.0	
1444	25 ☉	11.2		3.0	1.0	30	4.1	
1544	25 ☉	11.2		1.0	0.0	32	4.6	

Table 6.3 (cont.)

STANDARD METEOROLOGICAL DATA SHEET

Flight No C-398
Date 2 December 1976

Field Site Bruz Track
Lat 48°01'N – Long 1°41'W – El 46m

Time GMT	Sky and Ceiling (Hundreds of Feet)	Visibility (Kilometers)	Weather and Obstructions To Vision	Temp (C)	Dewpoint (°C)	Wind		Remarks
						Direction (00 – 36)	Speed (mps)	
RENNES-ST JACQUES (07130) 48°4'N 1°44'W Elev 37m North of Center of Track								
1100	MSG	11.2		8.0	3.0	28	9.2	
1200	30 ☉ 100 ☉	25.0		9.0	3.0	28	7.7	1/8 Cu 1/8 Ac
1300	MSG							
1400	250 ☉	11.2		8.0	3.0	30	2.0	2/8 Ci
1500	30 ☉ E100 ☉	8.0	R	6.0	3.0	26	7.2	3/8 Cu & Sc 5/8 Ac
1600	E 50 ☉ 100 ☉	11.2		6.0	4.0	00	0.0	5/8 Cu & Sc 7/8 Ac
ST NAZAIRE-MONTOIR (07217) 47°19'N 2°10'W Elev 3m South of Track								
1100	MSG	11.2		9.0	8.0	30	8.2	
1200	20 ☉ 100 ☉	30.0		10.0	3.0	30	6.2	1/8 Cb 2/8 Ac
1300	MSG							
1400	E 26 ☉ 100 ☉	8.0	RW-	7.0	4.0	28	7.2	5/8 Cb 7/8 Ac
1500	E 26 ☉	6.0	RW	8.0	5.0	28	8.2	8/8 Cb
1600	MSG	11.2	RW	8.0	5.0	28	7.7	
NANTES-CHATEAU BOUGON (07223) 47°19'N 1°36'W Elev 27m South of Track								
1100	150 ☉	11.2		9.0	4.0	28	9.2 G	Gusts to 14.4 1/8 Ac
1200	30 ☉ 150 ☉	25.0		10.0	2.0	26	8.2	1/8 Cb 2/8 Ac
1300	MSG							
1400	250 ☉	11.2		9.0	5.0	26	5.1	2/8 Ci
1500	30 ☉ 150 ☉ E250 ☉	20.0		6.0	5.0	22	3.1	1/8 Cb 2/8 Ac 5/8 Ci
1600	MSG	11.2		6.0	5.0	24	4.1	
ANBERS/AVRILLE (07230) 47°30'N 0°34'W Elev 57m Southeast of Track								
1100	MSG	11.2		8.0	6.0	28	7.2	
1200	E 16 ☉	15.0		8.0	3.0	30	6.2	5/8 Cu
1500	20 ☉ E100 ☉	15.0		8.0	3.0	28	5.1	5/8 Cu & Sc 5/8 Ac

Table 6.3 (cont.)

STANDARD METEOROLOGICAL DATA SHEET

Flight No C-399
Date 3 December 1976

Field Site Bruz Track
Lat 48°01'N – Long 1°41'W – El 46m

Time GMT	Sky and Ceiling (Hundreds of Feet)	Visibility (Kilometers)	Weather and Obstructions To Vision	Temp (°C)	Dewpoint (°C)	Wind		Remarks
						Direction (00 – 36)	Speed (mps)	
RENNES-ST JACQUES (07130) 48°4'N 1°44'W Elev 37m North of Center of Track								
1000	E 23 ☉ 230 ☉	11 2		5 0	3 0	22	1 5	5/8 Cb 7/8 Ci
1100	23 ☉ E230 ☉	11 2		6 0	3 0	26	4 1	3/8 Cb 7/8 Ci
1200	E 20 ☉ 230 ☉	25 0		7 0	3 0	24	3 6	6/8 Cu & Sc 7/8 Ci
1300	MSG							
1400	20 ☉ E230 ☉	11 2		7 0	3 0	22	4 1	3/8 Cb 7/8 Ci
ST NAZAIRE-MONTOIR (07217) 47°10'N 2°10'W Elev 3m South of Track								
1000	20 ☉ E230 ☉	11 2		7 0	3 0	30	2 0	2/8 Cb 6/8 Ci
1100	20 ☉ E230 ☉	11 2	RW-	6 0	3 0	24	4 6	2/8 Cb 6/8 Ci
1200	20 ☉ E230 ☉	15 0	RW-	6 0	3 0	26	4 1	3/8 Cb 7/8 Ci
1300	MSG							
1400	20 ☉ E230 ☉	11 2		6 0	3 0	24	2 5	1/8 Cb 3/8 Ci
NANTES-CHATEAU BOUGON (07222) 47°19'N 1°36'W Elev 27m South of Track								
1000	20 ☉ E250 ☉	11 2		6 0	4 0	18	3 0	3/8 Cb 7/8 Ci
1100	20 ☉ E100 ☉	11 2		7 0	5 0	20	2 0	2/8 Cb 6/8 Ac
1200	20 ☉ E100 ☉	30 0		6 0	4 0	24	3 1	2/8 Cb 7/8 Ac
1300	MSG							
1400	E 20 ☉ 200 ☉	11 2		5 0	3 0	26	2 0	5/8 Cb 7/8 Ac
ANBERS'AVRILLE (07230) 47°30'N 0°34'W Elev 57m Southeast of Track								
1100	20 ☉ E210 ☉	11 2		MSG		26	3 0	2/8 Cu & Sc
1200	20 ☉ E100 ☉	15 0		7 0	3 0	26	6 2	2/8 Cu & Sc 7/8 As
1400	20 ☉ E230 ☉	11 2		7 0	3 0	26	5 1	2/8 Cb 5/8 Ci

Table 6.3 (cont.)

STANDARD METEOROLOGICAL DATA SHEET

Flight No. C-400
Date: 4 December 1976

Field Site: Bruz Track
Lat. 48°01'N – Long. 1°41'W – El. 46m

Time GMT	Sky and Ceiling (Hundreds of Feet)	Visibility (Kilometers)	Weather and Obstructions	Temp. (°C)	Dewpoint (°C)	Wind		Remarks
						Direction (00–36)	Speed (mps)	
RENNES-ST. JACQUES (07130) 48°4'N 1°44'W Elev. 37m			North of Center of Track					
1000	15 ☉ E 90 ☉	11.2		3.0	2.0	28	3.6	2/8 Cb 7/8 Ci
1100	15 ☉ E250 ☉	11.2		5.0	4.0	28	4.6	1/8 Cb 4/8 Ci
1200	15 ☉ 250 ☉	35.0		6.0	4.0	28	3.1	1/8 Cb 3/8 Ci
1300	15 ☉ 230 ☉	11.2		6.0	3.0	24	3.0	2/8 Cb 4/8 Ci
1400	15 ☉ E230 ☉	11.2		7.0	3.0	24	3.0	2/8 Cb 5/8 Ci
ST. NAZAIRE-MONTOIR (07217) 47°19'N 2°10'W Elev. 3m			South of Track					
1000	15 ☉ 230 ☉	11.2		6.0	3.0	32	6.6	1/8 Cb 3/8 Ci
1100	15 ☉ 230 ☉	11.2		7.0	3.0	32	6.1	1/8 Cb 3/8 Ci
NANTES-CHATEAU BOUGON (07222) 47°19'N 1°36'W Elev. 27m			South of Track					
1000	25 ☉ 230 ☉	11.2		5.0	3.0	28	5.1	2/8 Cb 4/8 Ci
1100	25 ☉ 230 ☉	11.2		6.0	3.0	28	5.1	2/8 Cb 4/8 Ci
1200	25 ☉ 230 ☉	30.0		7.0	4.0	28	6.2	2/8 Cb 4/8 Ci
1300	25 ☉ 230 ☉	11.2		8.0	3.0	28	4.1	2/8 Cb 4/8 Ci
1400	25 ☉ E230 ☉	11.2		7.0	3.0	26	4.1	2/8 Cb 5/8 Ci
ANBERS/AVRILLE (07230) 47°30'N 0°34'W Elev. 57m			Southeast of Track					
1100	30 ☉ E250 ☉	11.2		4.0	3.0	30	7.2	3/8 Cb 5/8 Ci
1200	E 30 ☉	15.0		4.0	3.0	30	5.1	7/8 Cb
1500	30 ☉ 250 ☉	20.0		6.0	3.0	28	5.1	1/8 Cu 3/8 Ci

Table 6.3 (cont.)

STANDARD METEOROLOGICAL DATA SHEET

Flight No. C-401
Date: 5 December 1976

Field Site: Bruz Track
Lat. 48°01' N – Long. 1°41' W – El. 46 m

Time GMT	Sky and Ceiling (Hundreds of Feet)	Visibility (Kilometers)	Weather and Obstructions To Vision	Temp. (°C)	Dewpoint (°C)	Wind		Remarks
						Direction (00–36)	Speed (mps)	
RENNES-ST. JACQUES (07130) 48°41' N 1°44' W Elev. 37 m								North of Center of Track
1000	20 ☉ 250-☉	11.2		4.0	2.0	24	2.0	1/8 Cu & Sc 2/8 Ci
1100	20 ☉ 250-☉	11.2		6.0	3.0	26	2.0	1/8 Cu & Sc 2/8 Ci
1200	20 ☉ 250-☉	30.0		7.0	3.0	24	3.1	1/8 Cu 1/8 Ci
1300	20 ☉ 250-☉	11.2		8.0	2.0	24	3.0	1/8 Cu 1/8 Ci
1400	20 ☉ 250-☉	11.2		8.0	2.0	22	1.5	1/8 Sc 2/8 Ci
1500	20 ☉ 250-☉	35.0		8.0	1.0	18	3.1	1/8 Sc 2/8 Ci
ST. NAZAIRE-MONTOIR (07217) 47°19' N 2°10' W Elev. 3 m								South of Track
0900	20 ☉	30.0		4.0	2.0	30	2.6	2/8 Cu & Sc
NANTES-CHATEAU BOUGON (07222) 47°19' N 1°36' W Elev. 27 m								South of Track
1000	25 ☉	11.2		4.0	3.0	26	2.0	1/8 Cu & Sc
1100	25 ☉	11.2		6.0	3.0	28	2.0	1/8 Cu
1200	25 ☉ -150 ☉	30.0		8.0	3.0	26	3.1	1/8 Cu 1/8 Ac
1300	25 ☉ 250-☉	11.2		8.0	3.0	20	2.0	1/8 Cu 1/8 Ci
1400	25 ☉ 250-☉	11.2		9.0	3.0	22	2.0	1/8 Cu 1/8 Ci
1500	25 ☉ 250-☉	30.0		9.0	3.0	20	3.1	1/8 Cu 1/8 Ci
ANBERS/AVRILLE (07230) 47°30' N 0°34' W Elev. 57 m								Southeast of Track
1100	25 ☉	11.2		6.0	3.0	28	5.1	1/8 Sc
1200	☉	20.0		7.0	3.0	28	4.1	
1500	25 ☉ 250-☉	20.0		8.0	2.0	24	4.1	1/8 Cu 1/8 Ci

Table 6.3 (cont.)

STANDARD METEOROLOGICAL DATA SHEET

Flight No C-402
Date 6 December 1976

Field Site Bruz Track
Lat 48°01'N - Long 1°41'W - El 46m

Time GMT	Sky and Ceiling (Hundreds of Feet)	Visibility (Kilometers)	Weather and Obstructions To Vision	Temp (°C)	Dewpoint (°C)	Wind		Remarks
						Direction (00-36)	Speed (mps)	
RENNES-ST JACQUES (07130) 48°4'N 1°44'W Elev 37m						North of Center of Track		
1000	25 ☉	11.2		9.0	6.0	20	6.1	1/8 Cu & Sc
1100	25 ☉	11.2		10.0	6.0	22	9.7G	3/8 Cu & Sc Gusts to 16.9
1200	20 ☉ 150 ☉ 220-☉	20.0		9.0	6.0	20	6.2	3/8 Cb 4/8 Ac 5/8 Ci
1300	20 ☉ 150 ☉ 220-☉	11.2		10.0	6.0	22	7.2	3/8 Cb 4/8 Ac 5/8 Ci
1400	20 ☉ 150 ☉ 200-☉	11.2		11.0	6.0	20	8.2	3/8 Cb 6/8 Ac 7/8 Ci
1500	20 ☉ 200-☉	18.0		11.0	5.0	20	8.2	3/8 Cb 7/8 Ci
1600	20 ☉ 200-☉	11.2		10.0	6.0	20	9.7	3/8 Cu 7/8 Ci
ST NAIZAIRE-MONTOIR (07217) 47°19'N 2°10'W Elev 3m						South of Track		
1000	E 20 ☉ 150 ☉	11.2		11.0	6.0	24	9.7	5/8 Cu 6/8 Ac
1100	E 18 ☉ 150 ☉	11.2		9.0	6.0	24	14.4	5/8 Cb 6/8 Ac
1200	E 20 ☉ 150 ☉ 220 ☉	20.0		12.0	7.0	22	9.3	5/8 Cb 6/8 Ac 7/8 Ci
1300	E 20 ☉ 220 ☉	11.2		11.0	7.0	22	9.7	5/8 Cu & Sc 7/8 Ci
1400	E 25 ☉ 220 ☉	11.2		12.0	7.0	22	10.8	5/8 Cu 7/8 Ci
1500	E 23 ☉ 200 ☉	20.0		12.0	7.0	22	9.8	5/8 Cu & Sc 7/8 Ci
1600	E 23 ☉ 200 ☉	11.2		11.0	8.0	22	11.3G	6/8 Sc 7/8 Ci Gusts to 18.5
NANTES-CHATEAU BOUGON (07222) 47°19'N 1°36'W Elev 27m						South of Track		
1000	20 ☉ 150 ☉ E250 ☉	11.2		11.0	7.0	22	6.1	2/8 Cb 3/8 Ac 6/8 Ci
1100	25 ☉ E100 ☉ 250 ☉	11.2		11.0	7.0	22	7.2G	2/8 Cu 5/8 Ac 6/8 Ci Gusts to 12.3
1200	25 ☉ E 90 ☉ 250 ☉	20.0		11.0	7.0	22	6.2	2/8 Cu 5/8 Ac 6/8 Ci
1300	25 ☉ 150 ☉ 250-☉	12.0		12.0	7.0	20	7.2G	2/8 Cu 3/8 Ac 6/8 Ci Gusts to 14.4
1400	25 ☉ 150 ☉ 250-☉	12.0		12.0	8.0	20	7.2	2/8 Cu 3/8 Ac 6/8 Ci
1500	35 ☉ 150 ☉ 250-☉	20.0		11.0	8.0	18	6.2	3/8 Cu & Sc 4/8 Ac 6/8 Ci
1600	35 ☉ 150 ☉ E250 ☉	11.2		11.0	7.0	20	8.2	3/8 Cu & Ac 4/8 Ac 7/8 Ci

Table 6.3 (cont.)

STANDARD METEOROLOGICAL DATA SHEET

Flight No C-402

Date 6 December 1976

Field Site Bruz Track

Lat 48°01' N – Long 1°41' W – El 46m

Time GMT	Sky and Ceiling (Hundreds of Feet)	Visibility (Kilometers)	Weather and Obstructions To Vision	Temp (°C)	Dewpoint (°C)	Wind		Remarks
						Direction (00–36)	Speed (mps)	
ANBERS/AVRILLE (07230) 47°30' N 0°34' W Elev 57m				Southeast of Track				
0900	25 ☉ 250-☉	10 0		9 0	7 0	24	6 2	4/8 Cb 7/8 Ci
1100	25 ☉ 150-☉	11 2		11 0	7 0	22	6 1	3/8 Cb 6/8 Ac
1200	25 ☉ 150-☉	10 0		11 0	7 0	22	9 3	3/8 Cb 6/8 Ac
1400	25 ☉ 150-☉ 250-☉	11 2		12 0	6 0	22	9 2	3/8 Cu 4/8 Ac 5/8 Ci
1500	25 ☉ 250-☉	20 0		11 0	7 0	22	9 3	4/8 Cu 5/8 Ci

7. DATA PRESENTATION

7.1 AIRBORNE DATA AND FLIGHT SUMMARY

Between 25 October and 6 December 1976, thirteen flights were made in northern Germany. Twelve of these flights contain useable data profiles. Selected data for these flights are reported herein.

The 12 flights were conducted in northern Europe on three flight tracks in Denmark, France, and Germany (see Fig. 1-1). The latitude, longitude, and altitude of each flight track are given in Table 7.1. The terrain beneath two of the flight tracks, those in Germany and France, was low lying and flat, mostly cultivated farmlands. The flight track in Denmark was mostly over water.

The ground station operated from 1 November to 6 December 1976 near the flight tracks in Germany and France, but was not utilized during the flights in Denmark. Its location and dates of operation are also noted in Table 7.1.

Table 7.1

Location and Ground Elevation of Flight Tracks and Ground Sites

Field Site	Latitude	Longitude	Approximate Ground Elevation (meters)	Dates of Operation (1976)	Flight No.
Flight Track Bruz, France	48°01' N	1°41' W	46	Dec 2, 3, 4, 5, 6	C-398, C-399, C-400, C-401, C-402
Meppen, Germany	53°00' N	7°38' E	18	Nov 1, 2, 23	C-392, C-393, C-397
Rodby, Denmark	54°41' N	11°08' E	0	Oct 25, 26 Nov 18, 19	C-390, C-391, C-394, C-395
Ground Station Bruz, France (CELAR)	48°01' N	1°45' W		Dec 2, 3, 4, 5, 6	
Meppen, Germany (Erprobungsstelle 91)	52°52' N	7°23' E		Nov 1, 2, 8, 22, 23	

PHOTOGRAPHIC DOCUMENTATION

Sky and terrain conditions encountered during the data flights were documented photographically during each straight and level flight sequence, at each of several designated altitudes, in conjunction with the radiometric measurements made in each spectral filter. On sunlit days the documentary photographs were taken simultaneously with the measurements made by the upper hemisphere scanner in the sun mode. On overcast days the photographs were taken simultaneously with the measurements of sky and terrain radiance. One should be aware that while the photographs are instantaneous, the data measurements require a four-minute interval for completion. In four minutes the aircraft travels approximately ten miles.

The photographs illustrating sky and terrain conditions during each of the 12 flights have been examined and classified with respect to discernible cloud conditions. A summary of these general cloud and terrain descriptions, augmented by the descriptions given by the on-board meteorologist, is presented in Table 7.2.

The upper hemisphere cloud conditions appear to fall into three general categories: (1) scattered to broken clouds at low altitude, but clear at the highest altitude; (2) scattered to broken clouds all altitudes; (3) overcast.

Photographs illustrating typical sky and terrain conditions during four of the flights reported herein are shown in Figs. 7-1 and 7-2. In each instance, the picture on the left represents the sky (upper hemisphere) as seen through a 180-degree lens, and the picture on the right represents the terrain (lower hemisphere). The photographs were selected to represent the conditions encountered at both the highest and lowest flight altitudes during each of the four flights.

The pictures representing Flight C-397 (Fig. 7-2) illustrate the scattered to broken clouds at low altitudes and cloud free at high altitude conditions of category one, and the Meppen flight track in Germany. The underlying terrain was mostly cultivated farmlands.

The pictures representing Flight C-391 (Fig. 7-1) and C-401 (Fig. 7-2) illustrate the cloud conditions of category two. Flight C-391 was over the Rodby track in Denmark which was mostly over water in the Femer Bay. Flight C-401 was over the Bruz track in France, which was over heavily cultivated flat farmlands.

The pictures representing Flight C-392 (Fig. 7-1) illustrate the full overcast conditions of category three. Flight C-372 was over the Meppen track in Germany. The underlying terrain was again mostly cultivated farmlands.

RADIOMETRIC DOCUMENTATION

Table 7.3 contains a summary of pertinent descriptive information on the 12 flights for which radiometric data are reported herein. The flight numbers are sequential. The times under the total time of data-taking column are Greenwich Mean Time (GMT) and Local Civil Time (LCT). The LCT is equal to GMT+1. The sun zenith angles are tabulated for the time when data-taking began, at the time of sun transit (minimum sun zenith angle), and at the conclusion of the last data-taking. The maximum and minimum flight altitudes are noted in columns 12 and 13.

Table 7.2

Summary of Hemispherical Pictures and In-flight Meteorologists Descriptions

LOWER HEMISPHERE

Flight No	Filter No	~ 300 Meters	~ 1500 Meters	~ 3000 Meters	~ 6000 Meters
		(210 – 480 Meters)	(810 – 1530 Meters)	(1980 – 3840 Meters)	(4410 – 6090 Meters)
C-390	2,3	Heavy haze, water	Heavy haze, scattered clouds, water	Heavy haze, scattered clouds	Heavy haze, scattered clouds
	4,5	Heavy haze, water	Very heavy haze	Very heavy haze	Very heavy haze
C-391*	2	Thick haze or clouds	–	–	Thick haze or clouds
	3	Haze, water	–	–	Thick haze or clouds
	4	Haze, water	–	–	Thick clouds, almost solid deck
	5	–	Thick haze or clouds	–	Thick clouds, almost solid deck
C-392	2,3	Moderate haze, fields	Moderate haze fields	–	–
	4,5	Moderate haze, fields	Scattered clouds, moderate haze, fields	–	
C-393**	2	Scattered clouds, shadows, haze, fields	Scattered to broken clouds shadows, haze, fields	–	–
	3	Shadows, haze, fields	Scattered to broken clouds, shadows, haze, fields	–	–
	4	Shadows, haze, fields	Scattered to broken clouds, shadows, haze, fields	–	–
	5	Shadows, haze, fields	Scattered clouds, shadows, haze, fields	–	–
C-394	2,3	Light haze, water	Light haze, water	–	–
	4,5	Light haze, water	Light haze, water	–	–
C-395	2,3	Very light haze, water	–	Very light haze, water	Very light haze, water below, land horizon
	4,5	Very light haze, water	–	Very light haze, water	Very light haze, water below, land horizon
C-397**	2,3	Haze, scattered clouds, fields	–	–	Haze, scattered to broken clouds, fields
	4	Haze, fields	–	–	Haze, broken clouds, fields
	5	Haze, fields	–	–	Haze, broken clouds, fields
C-398	2	Very light haze, fields	Very light haze, occasional shadow, fields	Scattered clouds, very light haze, fields	Scattered clouds, light haze, fields
	4	Light haze, fields	Light haze, fields	Light haze, fields	Scattered clouds, light haze, fields
C-399	2,3	Light haze, fields	Scattered clouds, light haze, fields	Broken clouds, light haze, fields	–
	4,5	Light haze, fields	Scattered clouds, light haze, fields	Scattered clouds, light haze, fields	–
C-400**	2,3	Scattered clouds, light to moderate haze, fields	–	–	Nearly solid clouds
	4	Scattered clouds, haze, fields	–	–	Scattered clouds, haze, fields
	5	Scattered clouds, haze, fields	–	–	Scattered clouds, haze, fields
C-401	2,3	Very light haze, fields	Very light haze, fields	Very light haze, fields	Light haze, fields
	4,5	Shadows, light haze,	Light to moderate haze, fields	Some scattered clouds, light to moderate haze, fields	Scattered clouds, light to moderate haze, fields
C-402	2,3	Moderate haze, fields	Scattered clouds, moderate haze, fields, shadow	Scattered clouds, shadows, haze, fields	–
	4,5	Moderate haze, fields, shadows	Scattered clouds, moderate haze, shadows	Scattered clouds, light haze, shadow, field	–

* No in-flight meteorologist's descriptions to offset uncertainty in photographs.

** Most pictures are from V-Pro flight elements and thus altitudes are approximate.

Table 7.2 (cont.)

Summary of Hemispherical Pictures and In-flight Meteorologists Descriptions

UPPER HEMISPHERE

Flight No	Filter No	~ 300 Meters	~ 1500 Meters	~ 3000 Meters	~ 6000 Meters
		(210 – 480 Meters)	(810 – 1530 Meters)	(1980 – 3840 Meters)	(4260 – 6090 Meters)
C-390	2,3	Haze, no clouds	Scattered clouds on horizon	Scattered wispy clouds	Scattered thin clouds
	4,5	Scattered thin clouds	Scattered to broken thin clouds	Scattered to broken thin clouds	Scattered to broken thin clouds
C-391*	2	Clear ?	–	–	Clear ?
	3	Broken clouds	–	–	Clear ?
	4	Broken clouds	–	–	Scattered wisps ?
	5	Scattered wisps ?	–	–	Scattered wisps ?
C-392	2,3	Low broken, high overcast	Low broken, high overcast	–	–
	4,5	Low broken, high overcast	Thick overcast	–	–
C-393**	2	Thick overcast	Thick overcast	–	–
	3	Thick overcast	Thick overcast	–	–
	4	Thick overcast	Thick overcast	–	–
	5	Thick overcast	Thick overcast	–	–
C-394	2,3	Thick overcast	Thick overcast	–	–
	4,5	Thick overcast	Thick overcast	–	–
C-395	2,3	Broken clouds	–	Broken clouds	Broken to overcast
	4,5	Broken clouds	–	Broken clouds	Broken clouds "
C-397**	2,3	Scattered to broken thin clouds	–	–	Clear
	4	Scattered thin clouds	–	–	Clear
	5	Scattered clouds	–	–	Clear
C-398	2	Scattered clouds	Scattered clouds	Scattered clouds	Scattered clouds
	4	Scattered clouds	Scattered clouds	Scattered clouds	Scattered clouds
C-399	2,3	Overcast	Thin overcast	Thin overcast	–
	4,5	Thin overcast	Low scattered, high overcast	Thin overcast	–
C-400**	2,3	Scattered low clouds plus broken high clouds	–	–	Broken clouds
	4	Scattered low clouds plus broken high clouds	–	–	Broken clouds
	5	Scattered low clouds plus broken high clouds	–	–	Broken clouds
C-401	2,3	Scattered very thin clouds	Scattered very thin clouds	Scattered very thin clouds	Clear
	4,5	Scattered thin clouds	Scattered thin clouds	Scattered thin clouds	Scattered thin clouds
C-402	2,3	Scattered clouds	Broken clouds	Broken clouds	–
	4,5	Broken clouds	Broken clouds	Scattered thin clouds	–

* No in-flight meteorologist's descriptions to offset uncertainty in photographs

** Most pictures are from V-Pro flight elements and thus altitudes are approximate

Table 7.3

Flight Data Summary, Including ST & LV and V-PRO Flight Elements

Flight No.	Date (1976)	Flight Track	Total Time of Data Taking				Filter	Sun Zenith Angle (degrees)			Flight Altitude meters (AGL)	
			Start		End			Start	Transit	End	Min	Max
			GMT	LCT	GMT	LCT						
C-390	25 Oct	Rodby	1230	1330	1425	1525	2,3	69.6	—	79.7	270	6090
			1429	1529	1615	1715	4,5	80.1	—	93.7	300	6090
C-391	26 Oct	Rodby	1119	1219	1144	1244	2	67.4	—	67.9	270	5490
			1147	1247	1208	1308	3	68.0	—	68.8	270	5430
			1209	1309	1235	1335	4	68.9	—	70.2	300	5160
			1236	1336	1257	1357	5	70.3	—	71.6	840	5100
C-392	1 Nov	Meppen	1115	1215	1208	1308	2,3	67.6	—	68.6	420	1410
			1212	1312	1253	1353	4,5	68.7	—	71.0	360	1170
C-393	2 Nov	Meppen	1036	1136	1046	1146	2	68.3	—	68.1	300	1590
			1050	1150	1053	1153	3	68.0	—	68.0	270	1440
			1108	1208	1111	1211	4	67.9	—	67.9	360	1380
			1114	1214	1117	1217	5	67.9	—	67.9	330	1440
C-394	18 Nov	Rodby	1147	1247	1221	1321	2,3	74.7	—	76.0	210	900
			1225	1325	1259	1359	4,5	76.2	—	78.3	300	900
C-395	19 Nov	Rodby	1150	1250	1319	1419	2,3	75.0	—	79.9	300	4440
			1256	1356	1422	1522	4,5	78.2	—	85.8	300	4440
C-397	23 Nov	Meppen	1202	1302	1257	1357	2,3	74.1	—	76.7	300	4320
			1238	1338	1259	1359	4	75.5	—	76.8	330	4320
			1259	1359	1317	1417	5	76.8	—	78.0	300	4320
C-398	2 Dec	Bruz	1143	1243	1306	1406	2	70.1	70.0	71.8	420	4440
			1315	1415	1411	1511	4	72.2	—	76.3	450	4410
C-399	3 Dec	Bruz	1013	1113	1250	1350	2,3	73.9	70.2	71.2	390	2610
			1116	1216	1230	1330	4,5	70.8	70.2	70.6	420	2580
C-400	4 Dec	Bruz	1029	1129	1204	1304	2,3	73.0	70.3	70.3	480	5100
			1219	1319	1233	1333	4	70.5	—	70.8	480	5070
			1250	1350	1305	1405	5	71.3	—	72.0	480	5100
C-401	5 Dec	Bruz	1040	1140	1227	1337	2,3	72.5	70.4	70.8	390	5190
			1233	1333	1428	1528	4,5	70.9	—	78.2	420	5190
C-402	6 Dec	Bruz	1201	1301	1318	1418	2,3	70.6	—	72.9	390	3900
			1324	1424	1445	1545	4,5	73.2	—	79.9	420	3840

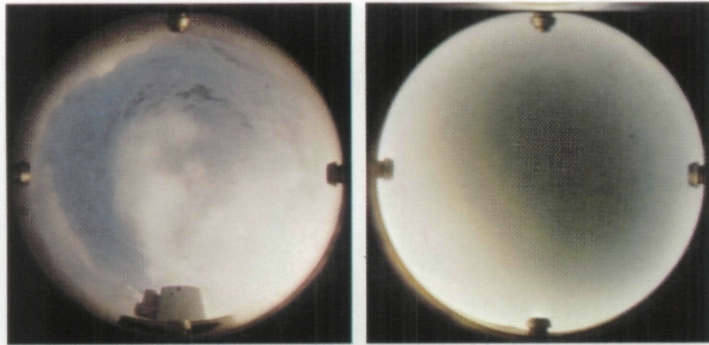

FLIGHT C-391
Rodby Track

Upper and Lower Hemisphere
270m AGL 1208 GMT

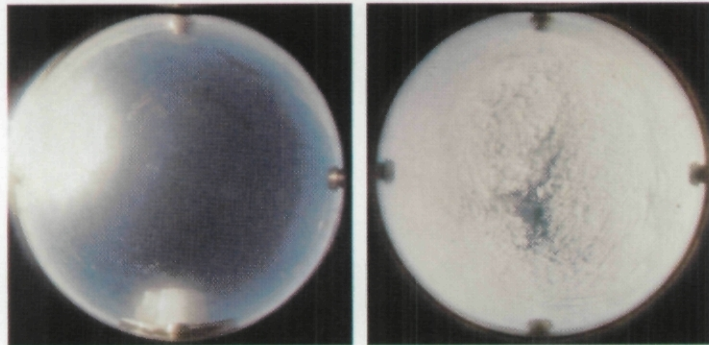

Upper and Lower Hemisphere
5130m AGL 1234 GMT

Fig. 7-1. Typical Sky and Terrain Photographs for Flights C-391 and C-392.

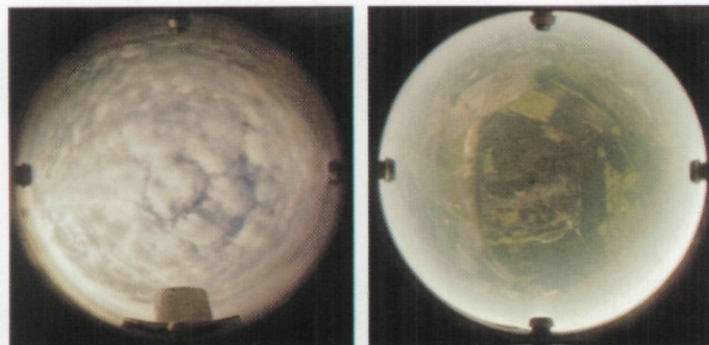

FLIGHT C-392
Meppen Track

Upper and Lower Hemisphere
390m AGL 1212 GMT

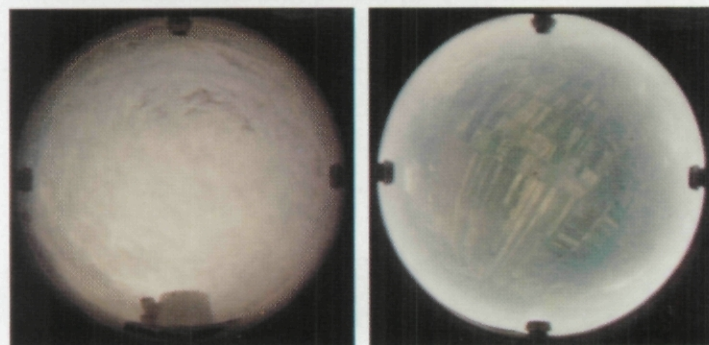

Upper and Lower Hemisphere
1170m AGL 1238 GMT

**FLIGHT C-397
Meppen Track**

Upper and Lower Hemisphere
600m AGL 1239 GMT

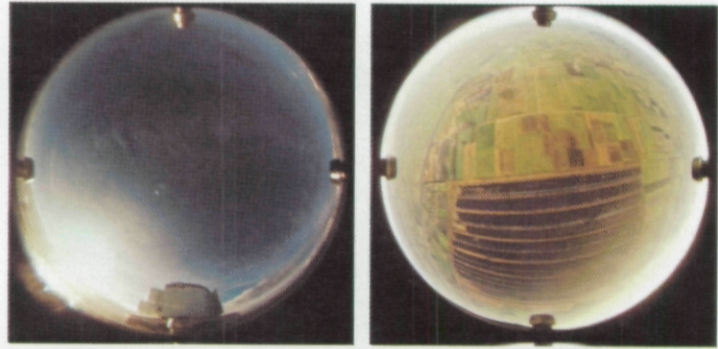

Upper and Lower Hemisphere
3900m AGL 1250 GMT

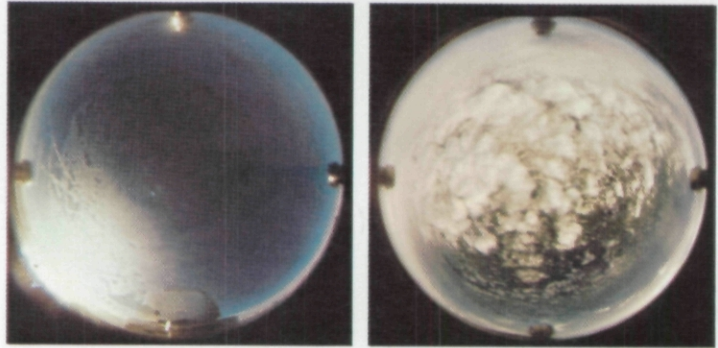
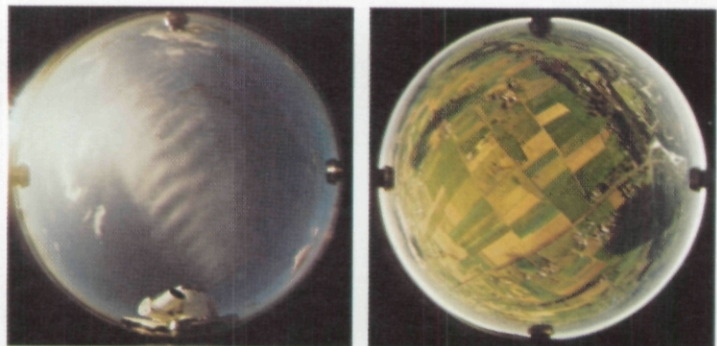

Fig. 7-2. Typical Sky and Terrain Photographs for Flights C-397 and C-401.

**FLIGHT C-401
Bruz Track**

Upper and Lower Hemisphere
420m AGL 1233 GMT



Upper and Lower Hemisphere
5160m AGL 1401 GMT

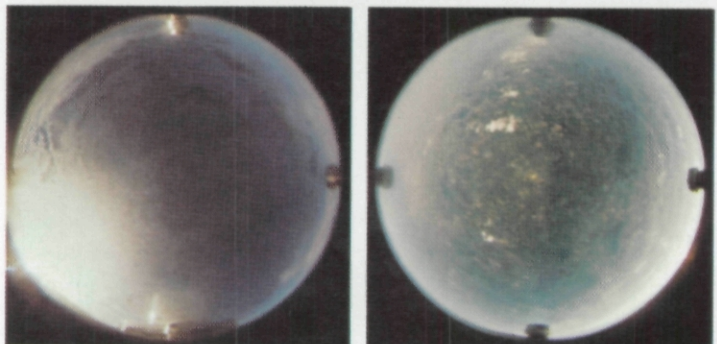

The total volume scattering coefficient, equivalent attenuation length and beam transmittance data are presented both tabularly and graphically in Section 7.3. The downwelling irradiance data are presented graphically only. All of the data are grouped into sets by flight number. A detailed description and report of the existing weather conditions are given as the introductory page to each data set.

Users should be alert to the fact that the data collected on ascents is taken in two or three segments separated in time by the straight and level flight elements. Thus the consecutive segments of these VPROS may be separated by as much as 10 to 15 minutes in time. At large solar zenith angles, this time gap can cause apparently anomalous profile appearances as in the filter 4 irradiance plot for Flight C-390. For more specific discussion of these and other profile characteristics, the user is referred to Section 8.2.

7.2 DESCRIPTION OF AIRBORNE DATA TABLES AND GRAPHS

DATA TABLES

Data are presented in tables of:

- Total Volume Scattering Coefficient
- Equivalent Attenuation Length
- Beam Transmittance Between Ground and Altitude

Each optical property is tabulated in the tables as a function of altitude above ground level. The data are further divided by optical filters which are given in order of increasing wavelength.

The tables have been divided into two categories depending upon the meaning of the altitude in the tables, (1) the variable tabulated by measurement altitude: total volume scattering coefficient, and (2) the variables tabulated by object or sensor altitude depending on whether the path of sight is upward or downward: equivalent attenuation length, and beam transmittance.

CATEGORY I: MEASUREMENT ALTITUDE

Total Volume Scattering Coefficient. The total volume scattering coefficient $s(z)$ is tabulated by measurement altitude in two to four columns for the optical filters. The altitude is given in meters, above ground level, at 30 meter (98.4-foot) increments. The measurement unit for the total scattering coefficient is " m^{-1} ." The extrapolated points above or below the actual altitudes of measurement are indicated by parentheses.

The first and last data altitudes are given at the bottom of the total scattering coefficient table. These are the lowest and highest altitudes of airborne data measurements.

The total scattering coefficient is used for the calculation of atmospheric beam transmittance and equivalent attenuation length in the ensuing tables using the equations of the Theory, Section 2.

CATEGORY II OBJECT OR SENSOR ALTITUDE

These variables are tabulated by object or sensor altitude depending upon whether the path of sight is upward or downward. For upward paths of sight $\theta < 90^\circ$ the sensor is at ground level and the altitudes shown in the table are the object altitudes. For the downward paths of sight $\theta > 90^\circ$, the object is at ground level and the altitudes in the table are the sensor altitudes.

Equivalent Attenuation Length The equivalent attenuation length $\bar{L}(z)$ is a pseudo-attenuation length which, when combined with its altitude z , can be used directly in Eq. 2.6 to compute beam transmittance. The equivalent attenuation length permits easy calculation of the atmospheric beam transmittance between ground level and altitude z above ground level for any downward path of sight from 95 degrees to 180 degrees in zenith angle or between altitude and ground level for any upward path of sight from 0 degrees to 85 degrees in zenith angle.

The equivalent attenuation length $\bar{L}(z)$ is tabulated by altitude for the path of sight between ground and the altitude shown in two to four columns for the optical filters. The altitude is given in meters, above ground level, at 300-meter (984-foot) increments. The unit for the equivalent attenuation length is "m".

Beam Transmittance Between Ground and Altitude The atmospheric beam transmittance is tabulated for the vertically upward path of sight $T_z(0,0^\circ)$ or the vertically downward path of sight $T_z(z,180^\circ)$ for the path of sight between ground and the altitude shown. The beam transmittance is computed from measurements of total scattering coefficient. The assumption is made that there is no significant atmospheric absorption in the pass bands of the measurements, whence the atmospheric attenuation coefficient $\alpha(z)$ is assumed equivalent to the scattering coefficient $s(z)$.

The vertical beam transmittance is tabulated by altitude for the path of sight between ground and the altitude shown in two to four columns for the optical filters. The altitude is given in meters, above ground level, at 300-meter (984-foot) increments. This property is dimensionless.

DATA GRAPHS

Data are also presented in graphs of

- Total Volume Scattering Coefficient
- Equivalent Attenuation Length, Between Ground and Altitude
- Vertical Beam Transmittance, Between Ground and Altitude
- Downwelling Irradiance

Total Volume Scattering Coefficient The total volume scattering coefficient $s(z)$ in m^{-1} is graphed using a single average value for each 30-meter altitude interval. Identifying symbols for the spectral filters appear every fifth data point, or at 150-meter intervals. These same data were tabulated in the total scattering coefficient table. The extrapolated values are indicated by a dashed line.

Equivalent Attenuation Length. The equivalent attenuation length $\bar{L}(z)$ in meters, for the path between ground and altitude, is graphed for each 30-meter altitude interval. This represents smaller altitude increments than in the tabular display of equivalent attenuation length. Spectral identifying symbols appear at 150-meter intervals or every fifth data point.

Vertical Beam Transmittance Between Ground and Altitude. The vertical beam transmittance $T_p(0,0^\circ)$ or $T_p(z,180^\circ)$ between ground and altitude is graphed for each 30-meter altitude interval. This represents smaller altitude increments than in the tabular display of beam transmittance. Spectral identifying symbols appear at 150-meter intervals or every fifth data point.

Downwelling Irradiance. The downwelling irradiance $H(z,d)$ is graphed as a function of altitude above ground level (AGL). These irradiances were measured by the dual irradiator concurrently with the total volume scattering coefficient measurements. The downwelling irradiance during the ascent or descent is graphed using a single average value for each 30-meter altitude interval and the identifying symbol for the spectral filter appears every fifth data point; thus when data are continuous the symbols appear at 150-meter intervals. The second symbol for each filter designates the average value measured during each three-minute straight and level flight element.

7.3 PRESENTATION OF AIRBORNE DATA

Tabular listings and graphical displays of the data discussed in Section 7.2 are presented in the pages immediately following. Users should be aware that regardless of the display format, the data values are valid to, at best, only three significant figures. The tables of beam transmittance, in particular, should be rounded off to 2 digits prior to further application.

It should also be remembered that all values in the data tables except scattering coefficient are computed values based upon the measured values of scattering coefficient.

All altitudes presented in the data tables, in the flight description, and in the graphs are given as above ground level (AGL) unless otherwise specified.

FLIGHT C-390 – 25 OCTOBER 1976 – DESCRIPTION OF FLIGHT AND WEATHER CHARACTERISTICS

Filter Ident	Data Interval			Solar Zenith Angle			Flight Altitude (meters)		Average Terrain Elevation (meters)
	Start (GMT)	End (GMT)	Elapsed (hrs) (min)	Initial (degrees)	Solar Transit (degrees)	Final (degrees)	(min)	(max)	
2,3	1230	1425	1 55	69.6	–	79.7	270	6090	0
4,5	1429	1615	1 46	80.1	–	93.7	300	6090	0

Flight C-390 was an afternoon flight. Scattered thin cirrus clouds gradually increased to a broken layer through the afternoon over the water with broken clouds at low levels over nearby land areas.

The approximate southeast to northwest Rodby track was located south of Lolland Island, Denmark. Typical terrain features along the nearby coast to the north of the track were flat cultivated farmlands interspersed with occasional woods and small towns. Directly beneath the track and to the south were the relatively shallow waters of Femer Bay.

The in-flight observer reported scattered stratocumulus clouds over land and scattered cirrus increasing to broken over the water. Heavy haze was present throughout the flight with tops about 1050 meters (3500 feet).

At Fehmarnbelt, south of the track, the sky was clear at 1200 GMT and 2/8 cirrus at 7500 meters (25000 feet) were present at 1500 GMT. Visibility was reported at 4.0 kilometers with light fog for both observations.

Kegnaes, located west of the western end of the track, reported stratus overcast at 270 meters (900 feet) at 1200 GMT becoming 5/8 stratus at 360 meters (1200 feet) and 4/8 altocumulus at 3600 meters (12000 feet) by 1500 GMT. Visibility was reported from 2.4 to 2.6 kilometers with light fog.

The radiosonde station at Schleswig was approximately 106 kilometers west and upstream from the flight track center point.

The surface chart for 1200 GMT had a stationary front dissipating east of the flight area along the Göteborg-Schwerin-Schweinfurt line. Another stronger frontal system paralleled and followed 3 degrees west of this front. Widespread fog is shown in advance of both frontal regions. At 500 millibars a high was located over eastern Poland and a trough of low pressure over Great Britain. Moderate southwesterly flow was over the region. The airmass was stable maritime polar.

FLIGHT NO. C-390

RODBY

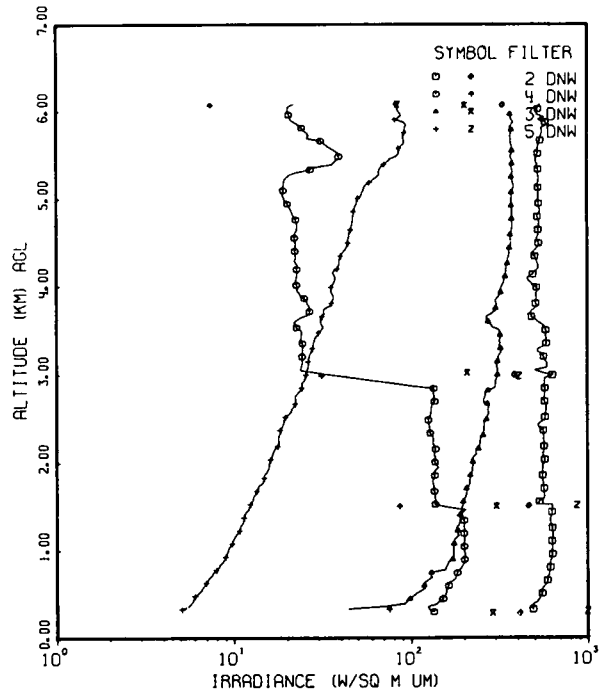
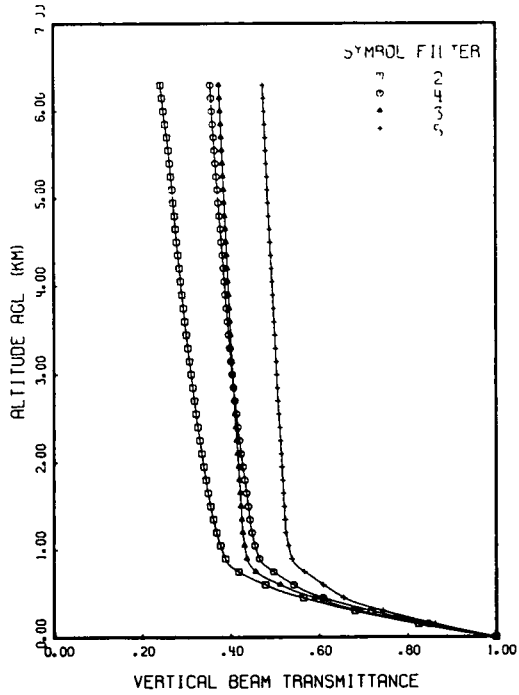
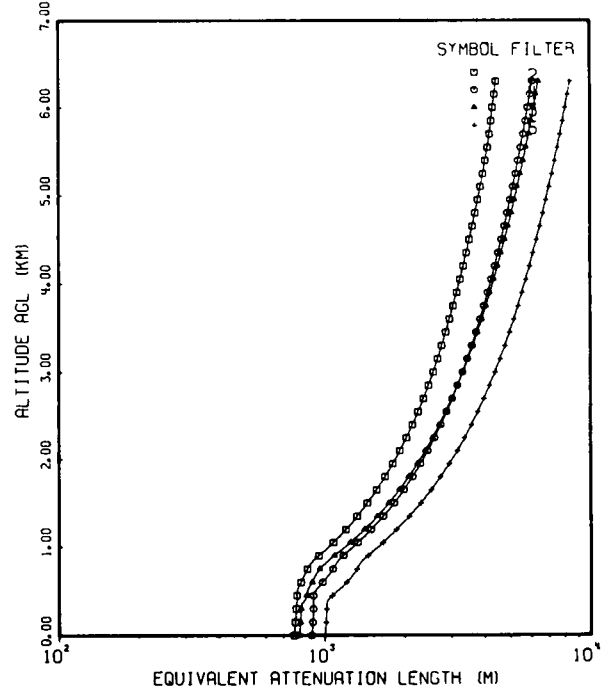
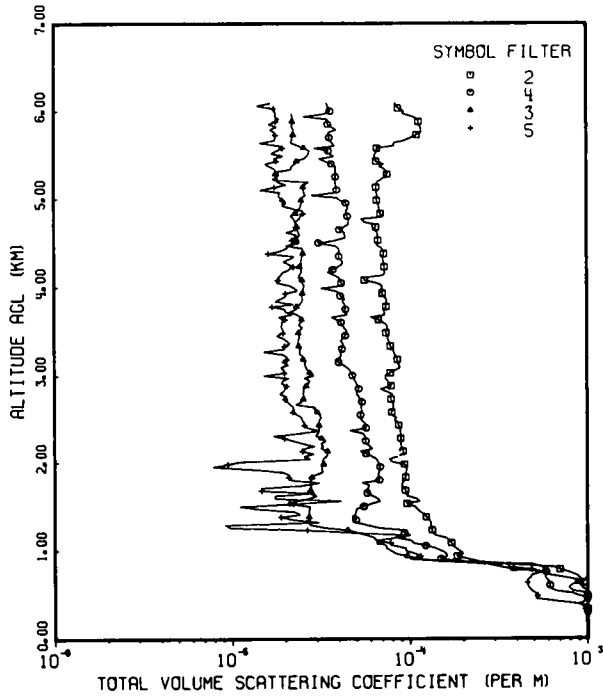

FLIGHT NO. C-390
TOTAL VOLUME SCATTERING COEFFICIENT

(JOB 4349 DATE 06/23/77)
 DATE 102576 FLIGHT NO. C-390 GROUND LEVEL ALTITUDE (M)= 0

ALTITUDE (M)	TOTAL VOLUME SCATTERING COEFFICIENT (PER M)			
	FILTERS	2	4	3
0	(1.30E-03)	(1.12E-03)	(1.25E-03)	(1.00E-03)
30	(1.30E-03)	(1.12E-03)	(1.24E-03)	(9.95E-04)
60	(1.29E-03)	(1.11E-03)	(1.24E-03)	(9.92E-04)
90	(1.29E-03)	(1.11E-03)	(1.24E-03)	(9.90E-04)
120	(1.29E-03)	(1.11E-03)	(1.23E-03)	(9.87E-04)
150	(1.28E-03)	(1.10E-03)	(1.23E-03)	(9.85E-04)
180	(1.28E-03)	(1.10E-03)	(1.23E-03)	(9.82E-04)
210	(1.28E-03)	(1.10E-03)	(1.22E-03)	(9.80E-04)
240	(1.27E-03)	(1.10E-03)	(1.22E-03)	(9.77E-04)
270	(1.27E-03)	(1.09E-03)	(1.22E-03)	(9.75E-04)
300	(1.27E-03)	1.09E-03	(1.21E-03)	(9.72E-04)
330	1.26E-03	1.12E-03	1.21E-03	9.70E-04
360	1.21E-03	1.11E-03	1.01E-03	9.57E-04
390	1.22E-03	1.11E-03	8.97E-04	8.83E-04
420	1.31E-03	1.10E-03	9.77E-04	6.70E-04
450	1.29E-03	1.05E-03	1.08E-03	5.10E-04
480	1.27E-03	9.05E-04	1.12E-03	5.22E-04
510	1.17E-03	8.17E-04	1.10E-03	5.09E-04
540	1.00E-03	6.51E-04	8.25E-04	4.85E-04
570	9.36E-04	6.06E-04	7.84E-04	4.68E-04
600	9.40E-04	6.13E-04	8.07E-04	4.62E-04
630	9.50E-04	6.13E-04	8.78E-04	4.58E-04
660	7.20E-04	5.96E-04	8.83E-04	4.57E-04
690	7.05E-04	5.77E-04	7.44E-04	4.80E-04
720	8.59E-04	5.82E-04	6.06E-04	4.90E-04
750	7.83E-04	5.83E-04	5.81E-04	5.55E-04
780	5.98E-04	5.73E-04	3.83E-04	4.85E-04
810	6.45E-04	5.52E-04	3.24E-04	3.58E-04
840	3.76E-04	4.88E-04	2.74E-04	3.55E-04
870	2.47E-04	2.13E-04	1.76E-04	1.59E-04
900	2.15E-04	1.49E-04	1.13E-04	9.97E-05
930	1.84E-04	1.62E-04	9.63E-05	1.14E-04
960	2.00E-04	1.60E-04	8.27E-05	1.06E-04
990	1.90E-04	1.50E-04	7.82E-05	9.48E-05
1020	1.82E-04	1.40E-04	7.38E-05	9.50E-05
1050	1.75E-04	1.22E-04	7.33E-05	7.95E-05
1080	1.71E-04	1.04E-04	6.73E-05	7.77E-05
1110	1.66E-04	1.01E-04	6.43E-05	6.45E-05
1140	1.61E-04	8.48E-05	6.28E-05	8.19E-05
1170	1.39E-04	1.00E-04	5.68E-05	9.27E-05
1200	1.33E-04	9.29E-05	5.02E-05	4.82E-05
1230	1.33E-04	9.31E-05	4.45E-05	2.63E-05
1260	1.31E-04	6.56E-05	3.27E-05	9.57E-06
1290	1.31E-04	5.70E-05	2.73E-05	9.13E-06
1320	1.31E-04	4.89E-05	2.74E-05	3.09E-05
1350	1.29E-04	4.95E-05	2.69E-05	2.19E-05
1380	1.23E-04	4.70E-05	2.70E-05	1.87E-05
1410	1.21E-04	4.92E-05	2.72E-05	2.41E-05
1440	1.14E-04	4.98E-05	2.69E-05	2.23E-05
1470	1.10E-04	4.96E-05	2.72E-05	1.44E-05
1500	1.06E-04	5.50E-05	2.73E-05	1.10E-05

FLIGHT NO. C-390
TOTAL VOLUME SCATTERING COEFFICIENT

(JOB 4349 DATE 06/23/77)
 DATE 102576 FLIGHT NO. C-390 GROUND LEVEL ALTITUDE (M)= 0

ALTITUDE (M)	TOTAL VOLUME SCATTERING COEFFICIENT (PER M)				
	FILTERS	2	4	3	5
1530		9.60E-05	6.04E-05	2.11E-05	2.21E-05
1560		1.14E-04	6.79E-05	2.26E-05	4.11E-05
1590		1.09E-04	6.55E-05	2.73E-05	1.72E-05
1620		9.59E-05	6.17E-05	3.00E-05	1.74E-05
1650		9.60E-05	5.74E-05	2.71E-05	2.88E-05
1680		9.41E-05	5.67E-05	2.75E-05	1.46E-05
1710		9.35E-05	5.80E-05	2.78E-05	1.46E-05
1740		8.97E-05	5.93E-05	2.77E-05	2.48E-05
1770		9.12E-05	5.40E-05	2.81E-05	3.09E-05
1800		9.28E-05	6.74E-05	2.76E-05	2.15E-05
1830		9.46E-05	6.70E-05	2.80E-05	2.07E-05
1860		9.40E-05	6.65E-05	2.95E-05	2.09E-05
1890		9.52E-05	6.72E-05	3.24E-05	1.92E-05
1920		9.64E-05	6.78E-05	3.19E-05	1.35E-05
1950		9.62E-05	6.81E-05	3.19E-05	7.76E-06
1980		9.30E-05	6.70E-05	3.27E-05	9.45E-06
2010		7.92E-05	6.63E-05	3.24E-05	1.11E-05
2040		7.68E-05	6.50E-05	3.24E-05	2.75E-05
2070		8.51E-05	6.16E-05	3.39E-05	2.53E-05
2100		9.28E-05	5.66E-05	3.43E-05	2.88E-05
2130		9.18E-05	5.27E-05	3.43E-05	2.48E-05
2160		7.10E-05	6.17E-05	3.17E-05	2.55E-05
2190		8.94E-05	5.95E-05	3.24E-05	2.92E-05
2220		8.90E-05	5.66E-05	3.17E-05	2.49E-05
2250		8.90E-05	5.64E-05	3.38E-05	2.23E-05
2280		8.90E-05	5.62E-05	3.18E-05	1.97E-05
2310		8.90E-05	5.58E-05	2.96E-05	1.71E-05
2340		8.90E-05	5.44E-05	3.06E-05	2.40E-05
2370		8.82E-05	4.60E-05	3.08E-05	3.09E-05
2400		8.82E-05	5.66E-05	3.08E-05	2.64E-05
2430		8.65E-05	5.70E-05	3.08E-05	2.55E-05
2460		8.68E-05	5.57E-05	3.08E-05	2.56E-05
2490		8.22E-05	5.35E-05	3.10E-05	2.49E-05
2520		8.47E-05	5.32E-05	3.16E-05	2.47E-05
2550		7.89E-05	5.30E-05	3.13E-05	2.33E-05
2580		7.92E-05	5.33E-05	3.02E-05	2.19E-05
2610		8.09E-05	5.37E-05	2.92E-05	2.23E-05
2640		8.09E-05	5.33E-05	2.94E-05	2.22E-05
2670		8.09E-05	5.33E-05	2.29E-05	2.12E-05
2700		7.99E-05	5.39E-05	2.46E-05	2.05E-05
2730		7.85E-05	5.24E-05	2.52E-05	1.99E-05
2760		7.91E-05	5.17E-05	2.55E-05	2.03E-05
2790		8.00E-05	5.03E-05	2.51E-05	1.85E-05
2820		7.37E-05	5.09E-05	2.53E-05	1.96E-05
2850		6.85E-05	5.17E-05	2.53E-05	1.98E-05
2880		7.87E-05	5.09E-05	2.62E-05	2.03E-05
2910		7.67E-05	5.01E-05	2.70E-05	1.92E-05
2940		7.53E-05	4.93E-05	2.75E-05	1.94E-05
2970		7.31E-05	4.84E-05	2.55E-05	2.09E-05
3000		7.30E-05	4.76E-05	2.88E-05	1.51E-05

FLIGHT NO. C-390
TOTAL VOLUME SCATTERING COEFFICIENT

(JOB 4349 DATE 06/23/77)
 DATE 102576 FLIGHT NO. C-390 GROUND LEVEL ALTITUDE (M)= 0

ALTITUDE (M)	FILTERS	TOTAL VOLUME SCATTERING COEFFICIENT (PER M)			
		2	4	3	5
3030	7.81E-05	4.68E-05	2.75E-05	1.97E-05	
3060	8.32E-05	4.59E-05	2.66E-05	1.95E-05	
3090	8.82E-05	4.44E-05	2.62E-05	1.89E-05	
3120	8.71E-05	4.21E-05	2.58E-05	2.08E-05	
3150	8.59E-05	3.98E-05	2.60E-05	1.92E-05	
3180	8.53E-05	3.81E-05	2.52E-05	2.04E-05	
3210	8.46E-05	4.10E-05	2.55E-05	2.04E-05	
3240	8.21E-05	4.08E-05	2.41E-05	1.94E-05	
3270	8.15E-05	4.08E-05	2.41E-05	1.51E-05	
3300	8.01E-05	4.17E-05	2.44E-05	1.96E-05	
3330	7.81E-05	4.26E-05	2.38E-05	1.98E-05	
3360	7.71E-05	4.21E-05	2.35E-05	2.13E-05	
3390	7.63E-05	4.09E-05	2.37E-05	2.03E-05	
3420	7.55E-05	4.26E-05	2.39E-05	1.94E-05	
3450	7.49E-05	4.36E-05	2.41E-05	1.79E-05	
3480	7.37E-05	4.45E-05	2.37E-05	1.94E-05	
3510	7.50E-05	4.42E-05	2.43E-05	1.94E-05	
3540	7.49E-05	4.28E-05	2.50E-05	1.91E-05	
3570	7.46E-05	4.18E-05	2.37E-05	1.92E-05	
3600	7.09E-05	4.13E-05	2.48E-05	1.92E-05	
3630	6.67E-05	3.88E-05	2.48E-05	1.99E-05	
3660	6.05E-05	3.64E-05	2.44E-05	1.83E-05	
3690	7.32E-05	4.47E-05	2.31E-05	2.18E-05	
3720	7.20E-05	4.26E-05	2.12E-05	2.01E-05	
3750	7.27E-05	4.37E-05	2.32E-05	2.00E-05	
3780	7.38E-05	4.31E-05	2.32E-05	1.68E-05	
3810	7.39E-05	4.32E-05	2.44E-05	2.22E-05	
3840	7.40E-05	4.20E-05	2.49E-05	1.76E-05	
3870	7.42E-05	4.33E-05	2.49E-05	1.89E-05	
3900	7.10E-05	4.09E-05	2.49E-05	2.02E-05	
3930	7.03E-05	4.10E-05	2.50E-05	2.00E-05	
3960	6.79E-05	3.81E-05	2.52E-05	2.35E-05	
3990	7.06E-05	3.19E-05	2.53E-05	2.26E-05	
4020	7.02E-05	4.28E-05	2.55E-05	2.11E-05	
4050	6.51E-05	4.13E-05	2.49E-05	1.79E-05	
4080	5.58E-05	4.04E-05	2.48E-05	1.82E-05	
4110	5.50E-05	4.01E-05	2.38E-05	1.85E-05	
4140	7.21E-05	3.73E-05	2.42E-05	1.90E-05	
4170	7.26E-05	3.44E-05	2.47E-05	1.95E-05	
4200	7.26E-05	3.72E-05	2.45E-05	2.11E-05	
4230	7.23E-05	3.94E-05	2.41E-05	2.22E-05	
4260	7.19E-05	4.17E-05	2.49E-05	2.10E-05	
4290	7.15E-05	4.25E-05	2.44E-05	1.95E-05	
4320	7.10E-05	4.02E-05	2.47E-05	2.13E-05	
4350	7.04E-05	4.01E-05	2.49E-05	2.26E-05	
4380	7.18E-05	4.00E-05	2.52E-05	1.60E-05	
4410	7.06E-05	4.02E-05	2.51E-05	1.88E-05	
4440	7.04E-05	4.01E-05	2.49E-05	2.05E-05	
4470	6.61E-05	3.79E-05	2.01E-05	2.07E-05	
4500	6.63E-05	3.08E-05	2.39E-05	2.28E-05	

FLIGHT NO. C-390

TOTAL VOLUME SCATTERING COEFFICIENT

(JOB 4349 DATE 06/23/77)
 DATE 102576 FLIGHT NO. C-390 GROUND LEVEL ALTITUDE (M)= 0

ALTITUDE (M)	FILTERS	TOTAL VOLUME SCATTERING COEFFICIENT (PER M)			
		2	4	3	5
4530	6.66E-05	3.83E-05	2.32E-05	2.19E-05	
4560	6.68E-05	4.36E-05	2.35E-05	2.27E-05	
4590	6.63E-05	4.33E-05	2.41E-05	2.33E-05	
4620	6.61E-05	4.30E-05	2.38E-05	2.04E-05	
4650	6.32E-05	4.04E-05	2.34E-05	2.31E-05	
4680	6.48E-05	4.29E-05	2.33E-05	2.31E-05	
4710	6.47E-05	4.54E-05	2.30E-05	2.30E-05	
4740	5.55E-05	4.55E-05	2.27E-05	2.30E-05	
4770	5.36E-05	4.55E-05	2.24E-05	2.43E-05	
4800	7.12E-05	4.50E-05	2.14E-05	2.43E-05	
4830	6.88E-05	4.42E-05	2.28E-05	2.53E-05	
4860	6.78E-05	4.41E-05	2.37E-05	2.49E-05	
4890	6.78E-05	4.54E-05	2.42E-05	2.20E-05	
4920	6.72E-05	4.47E-05	2.45E-05	1.91E-05	
4950	6.65E-05	4.40E-05	2.49E-05	2.04E-05	
4980	6.58E-05	4.08E-05	2.47E-05	1.94E-05	
5010	6.58E-05	3.95E-05	2.51E-05	1.86E-05	
5040	6.59E-05	2.81E-05	2.61E-05	1.84E-05	
5070	6.57E-05	3.89E-05	2.56E-05	1.90E-05	
5100	6.52E-05	3.92E-05	2.54E-05	1.45E-05	
5130	6.52E-05	3.89E-05	2.53E-05	1.74E-05	
5160	6.61E-05	3.86E-05	2.58E-05	2.04E-05	
5190	6.59E-05	3.84E-05	2.72E-05	1.83E-05	
5220	6.96E-05	3.83E-05	1.69E-05	1.82E-05	
5250	7.33E-05	3.86E-05	1.81E-05	1.80E-05	
5280	7.55E-05	3.89E-05	1.77E-05	1.79E-05	
5310	7.44E-05	3.85E-05	1.79E-05	1.77E-05	
5340	7.34E-05	3.84E-05	2.17E-05	1.76E-05	
5370	6.82E-05	3.89E-05	2.18E-05	1.64E-05	
5400	7.24E-05	3.66E-05	2.29E-05	1.54E-05	
5430	6.53E-05	3.37E-05	2.34E-05	1.79E-05	
5460	6.45E-05	3.12E-05	2.57E-05	1.73E-05	
5490	6.38E-05	3.79E-05	2.67E-05	1.96E-05	
5520	6.50E-05	3.52E-05	2.73E-05	1.68E-05	
5550	6.62E-05	3.52E-05	2.76E-05	1.81E-05	
5580	6.61E-05	2.94E-05	2.56E-05	1.94E-05	
5610	8.26E-05	3.82E-05	2.36E-05	1.85E-05	
5640	8.23E-05	3.70E-05	2.16E-05	1.45E-05	
5670	9.58E-05	3.58E-05	2.19E-05	1.75E-05	
5700	1.03E-04	3.56E-05	2.21E-05	1.76E-05	
5730	1.11E-04	3.55E-05	2.23E-05	1.77E-05	
5760	1.18E-04	3.51E-05	2.24E-05	1.74E-05	
5790	1.17E-04	3.91E-05	2.24E-05	1.66E-05	
5820	1.16E-04	3.68E-05	2.20E-05	1.81E-05	
5850	1.14E-04	3.49E-05	2.20E-05	1.63E-05	
5880	1.14E-04	3.52E-05	2.21E-05	1.78E-05	
5910	1.12E-04	3.47E-05	2.23E-05	1.86E-05	
5940	1.05E-04	2.54E-05	2.21E-05	1.76E-05	
5970	9.23E-05	3.37E-05	2.18E-05	1.79E-05	
6000	9.38E-05	3.61E-05	(2.18E-05)	1.76E-05	

FLIGHT NO. C-390
TOTAL VOLUME SCATTERING COEFFICIENT

(JOB 4349 DATE 06/23/77)
 DATE 102576 FLIGHT O. C-390 GROUND LEVEL ALTITUDE (M)- 0

ALTITUDE (M)	FILTERS	TOTAL VOLUME SCATTERING COEFFICIENT (PER M)			
		2	4	3	5
6030		8.68E-05	3.53E-05	(2.17E-05)	1.73E-05
6060		8.53E-05	3.49E-05	(2.16E-05)	1.79E-05
6090		8.37E-05	3.44E-05	(2.15E-05)	1.66E-05
6120	(8.34E-05)	(3.43E-05)	(2.15E-05)	(1.65E-05)	
6150	(8.32E-05)	(3.42E-05)	(2.14E-05)	(1.65E-05)	
6180	(8.27E-05)	(3.41E-05)	(2.13E-05)	(1.64E-05)	
6210	(8.26E-05)	(3.40E-05)	(2.13E-05)	(1.64E-05)	
6240	(8.23E-05)	(3.39E-05)	(2.12E-05)	(1.63E-05)	
6270	(8.21E-05)	(3.38E-05)	(2.11E-05)	(1.63E-05)	
6300	(8.19E-05)	(3.37E-05)	(2.11E-05)	(1.62E-05)	
FIRST DATA ALT		330	300	330	330
LAST DATA ALT		6090	6090	5970	6090

FLIGHT NO. C-390 EQUIVALENT ATTENUATION LENGTH

(JOB 4349 DATE 06/23/77)
DATE 102576 FLIGHT NO. C-390 GROUND LEVEL ALTITUDE (M)= 0

ALTITUDE (M)	EQUIVALENT ATTENUATION LENGTH (M)			
	FILTERS	2	4	3
0	7.67E 02	8.92E 02	8.01E 02	1.00E 03
300	7.79E 02	9.05E 02	8.13E 02	1.02E 03
600	8.12E 02	9.82E 02	8.96E 02	1.21E 03
900	9.50E 02	1.18E 03	1.09E 03	1.46E 03
1200	1.20E 03	1.49E 03	1.41E 03	1.86E 03
1500	1.45E 03	1.83E 03	1.74E 03	2.30E 03
1800	1.69E 03	2.15E 03	2.07E 03	2.74E 03
2100	1.92E 03	2.45E 03	2.39E 03	3.17E 03
2400	2.14E 03	2.74E 03	2.71E 03	3.58E 03
2700	2.36E 03	3.03E 03	3.01E 03	3.98E 03
3000	2.57E 03	3.31E 03	3.32E 03	4.39E 03
3300	2.77E 03	3.59E 03	3.62E 03	4.79E 03
3600	2.96E 03	3.86E 03	3.92E 03	5.18E 03
3900	3.15E 03	4.13E 03	4.21E 03	5.56E 03
4200	3.34E 03	4.39E 03	4.50E 03	5.94E 03
4500	3.52E 03	4.65E 03	4.78E 03	6.31E 03
4800	3.70E 03	4.89E 03	5.07E 03	6.67E 03
5100	3.87E 03	5.13E 03	5.34E 03	7.02E 03
5400	4.04E 03	5.37E 03	5.62E 03	7.38E 03
5700	4.19E 03	5.61E 03	5.88E 03	7.73E 03
6000	4.31E 03	5.85E 03	6.15E 03	8.08E 03
6300	4.44E 03	6.08E 03	6.42E 03	8.43E 03

FLIGHT NO. C-390 VERTICAL BEAM TRANSMITTANCE FROM GROUND TO ALTITUDE

ALTITUDE (M)	VERTICAL BEAM TRANSMITTANCE FROM GROUND TO ALTITUDE			
	FILTERS	2	4	3
0	1.00E 00	1.00E 00	1.00E 00	1.00E 00
300	6.80E-01	7.18E-01	6.91E-01	7.44E-01
600	4.78E-01	5.43E-01	5.12E-01	6.09E-01
900	3.88E-01	4.65E-01	4.37E-01	5.39E-01
1200	3.68E-01	4.48E-01	4.27E-01	5.25E-01
1500	3.55E-01	4.40E-01	4.23E-01	5.21E-01
1800	3.44E-01	4.32E-01	4.20E-01	5.18E-01
2100	3.35E-01	4.24E-01	4.16E-01	5.15E-01
2400	3.26E-01	4.17E-01	4.12E-01	5.11E-01
2700	3.18E-01	4.10E-01	4.08E-01	5.08E-01
3000	3.11E-01	4.04E-01	4.05E-01	5.05E-01
3300	3.03E-01	3.99E-01	4.02E-01	5.02E-01
3600	2.97E-01	3.94E-01	3.99E-01	4.99E-01
3900	2.90E-01	3.89E-01	3.96E-01	4.96E-01
4200	2.85E-01	3.84E-01	3.93E-01	4.93E-01
4500	2.79E-01	3.80E-01	3.90E-01	4.90E-01
4800	2.73E-01	3.75E-01	3.88E-01	4.87E-01
5100	2.68E-01	3.70E-01	3.85E-01	4.84E-01
5400	2.62E-01	3.66E-01	3.82E-01	4.81E-01
5700	2.57E-01	3.62E-01	3.80E-01	4.79E-01
6000	2.48E-01	3.58E-01	3.77E-01	4.76E-01
6300	2.42E-01	3.55E-01	3.75E-01	4.74E-01

FLIGHT C-391 – 26 OCTOBER 1976 – DESCRIPTION OF FLIGHT AND WEATHER CHARACTERISTICS

Filter Ident	Data Interval			Solar Zenith Angle			Flight Altitude (meters)		Average Terrain Elevation (meters)
	Start (GMT)	End (GMT)	Elapsed (hrs) (min)	Initial (degrees)	Solar Transit (degrees)	Final (degrees)	(min)	(max)	
2	1119	1144	0 25	67.4	–	67.9	270	5490	0
3	1147	1208	0 21	68.0	–	68.8	270	5430	0
4	1209	1235	0 26	68.9	–	70.2	300	5160	0
5	1236	1257	0 21	70.3	–	71.6	840	5100	0

Flight C-391 was an afternoon flight. There was a solid deck of low clouds along the flight track.

The approximate southeast to northwest Rodby track was located south of Lolland Island, Denmark. Typical terrain features along the nearby coast to the north of the track were flat cultivated farmlands interspersed with occasional woods and small towns. Directly beneath the track and to the south were the relatively shallow waters of Femer Bay.

An in-flight lay observer reported a solid cloud deck along the track with cloud tops approximately 900 meters (3000 feet). There was no on-board meteorologist during this flight.

Fehmarnbelt, south of the track, reported 5/8 cumulus and stratocumulus at 450 meters (1500 feet) at 1200 GMT increasing to 8/8 stratocumulus by 1500 GMT. Visibility reported at 2.0 kilometers in fog at 1200 GMT improved to 4.0 kilometers in light fog at 1500 GMT.

Kegnaes, located west of the western end of the track, reported overcast stratocumulus at 480 meters (1600 feet) at 1200 GMT lowering to 420 meters (1400 feet) at 1500 GMT. Visibility was reported as 3.0 to 4.0 kilometers in light fog.

The radiosonde station at Schleswig was approximately 106 kilometers west of the flight track center point on a line that ran crosswind to the prevailing airflow.

The surface chart for 1200 GMT had an occluded front extending from a low centered at 58.5N, 8.0W. This front extended east and southeast through the North Sea and central Netherlands then as a stationary front through western Germany and Switzerland. Stratus and ground fog are prevalent in advance of the system. At 500 millibars a high was centered over southern Sweden with light southerly winds over Denmark. The airmass was stable maritime polar.

FLIGHT NO. C-391

RODBY

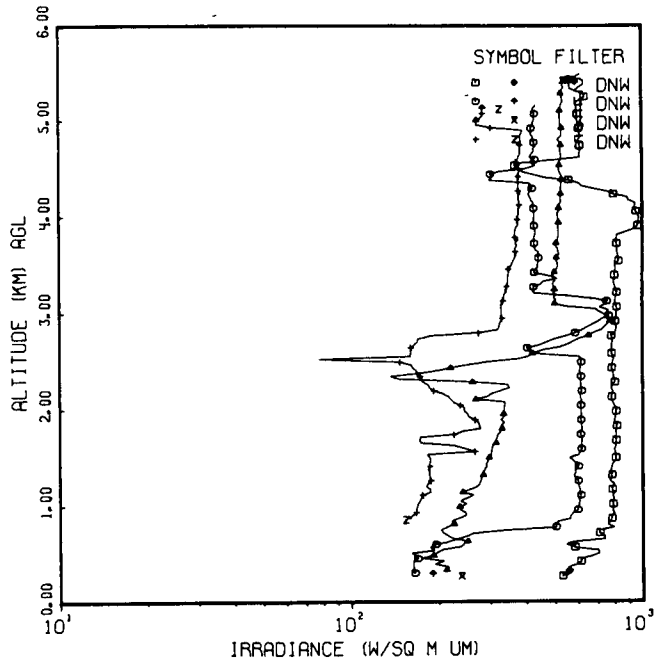
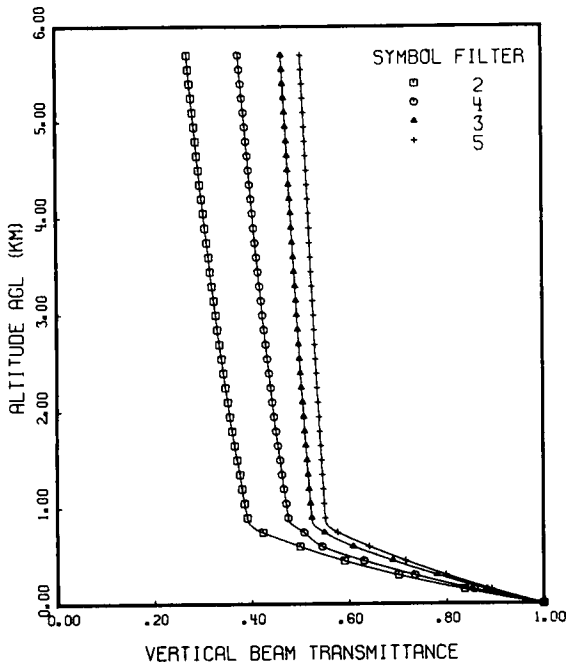
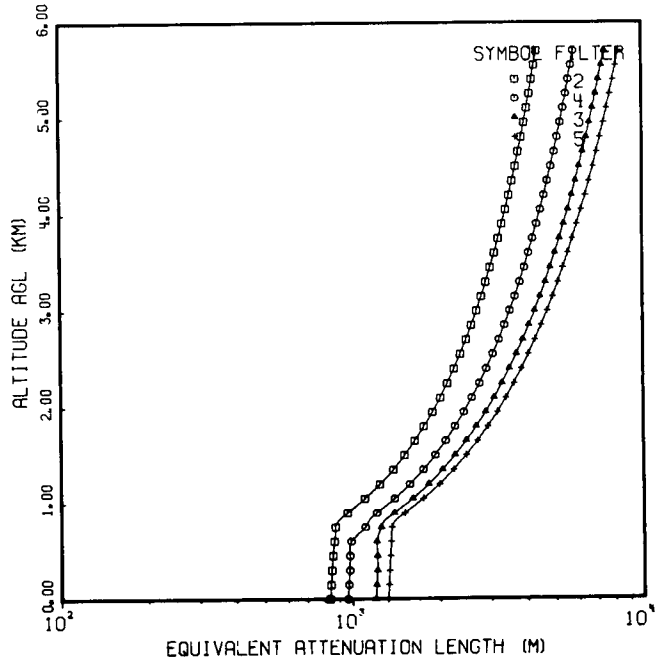
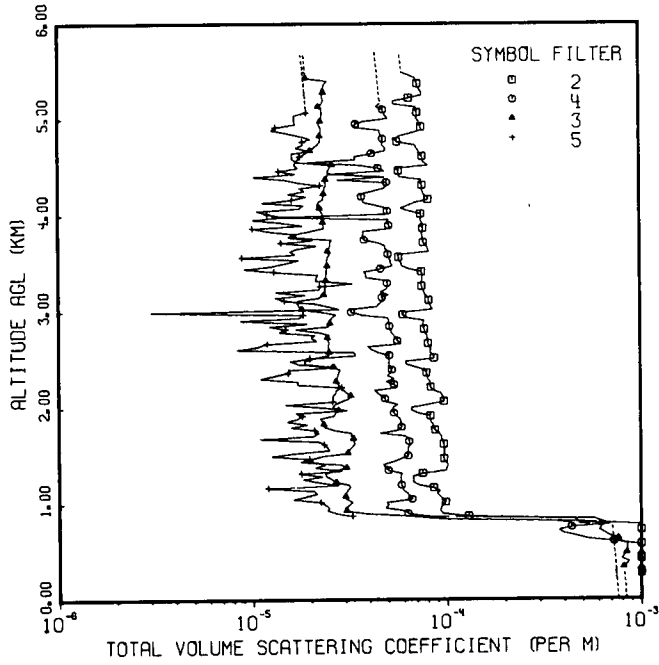

FLIGHT NO. C-391
TOTAL VOLUME SCATTERING COEFFICIENT

(JOB 4389 DATE 09/30/77)
 DATE 102676 FLIGHT NO. C-391 GROUND LEVEL ALTITUDE (M)= 0

ALTITUDE (M)	TOTAL VOLUME SCATTERING COEFFICIENT (PER M)			
	FILTERS	2	4	3
0	(1.20E-03)	(1.04E-03)	(8.37E-04)	(7.59E-04)
30	(1.19E-03)	(1.04E-03)	(8.32E-04)	(7.55E-04)
60	(1.19E-03)	(1.03E-03)	(8.30E-04)	(7.53E-04)
90	(1.19E-03)	(1.03E-03)	(8.28E-04)	(7.52E-04)
120	(1.19E-03)	(1.03E-03)	(8.26E-04)	(7.50E-04)
150	(1.18E-03)	(1.03E-03)	(8.24E-04)	(7.48E-04)
180	(1.18E-03)	(1.02E-03)	(8.22E-04)	(7.46E-04)
210	(1.18E-03)	(1.02E-03)	(8.20E-04)	(7.44E-04)
240	(1.17E-03)	(1.02E-03)	(8.18E-04)	(7.42E-04)
270	1.17E-03	(1.02E-03)	(8.16E-04)	(7.40E-04)
300	1.15E-03	1.01E-03	(8.13E-04)	(7.38E-04)
330	1.14E-03	1.04E-03	8.11E-04	(7.36E-04)
360	1.15E-03	9.99E-04	8.41E-04	(7.34E-04)
390	1.14E-03	1.00E-03	8.64E-04	(7.32E-04)
420	1.14E-03	1.04E-03	7.89E-04	(7.30E-04)
450	1.14E-03	1.02E-03	8.15E-04	(7.28E-04)
480	1.14E-03	1.03E-03	8.42E-04	(7.26E-04)
510	1.14E-03	1.02E-03	8.51E-04	(7.24E-04)
540	1.11E-03	1.01E-03	8.46E-04	(7.22E-04)
570	1.08E-03	9.53E-04	8.48E-04	(7.20E-04)
600	1.07E-03	7.21E-04	7.77E-04	(7.18E-04)
630	1.02E-03	5.25E-04	7.60E-04	(7.16E-04)
660	1.15E-03	4.60E-04	6.83E-04	(7.14E-04)
690	1.13E-03	3.94E-04	6.44E-04	(7.12E-04)
720	1.11E-03	3.75E-04	6.06E-04	(7.10E-04)
750	1.13E-03	4.37E-04	6.22E-04	(7.08E-04)
780	9.69E-04	6.89E-04	6.19E-04	(5.39E-04)
810	4.71E-04	6.28E-04	5.03E-04	(3.70E-04)
840	4.53E-04	5.67E-04	9.64E-05	(2.01E-04)
870	1.29E-04	7.86E-05	6.73E-05	3.27E-05
900	9.49E-05	6.29E-05	3.81E-05	2.69E-05
930	9.24E-05	6.03E-05	3.03E-05	2.41E-05
960	9.32E-05	4.84E-05	2.99E-05	2.48E-05
990	9.50E-05	5.01E-05	3.16E-05	2.36E-05
1020	9.84E-05	4.89E-05	3.26E-05	2.24E-05
1050	9.51E-05	6.61E-05	3.04E-05	1.62E-05
1080	9.21E-05	6.37E-05	3.01E-05	1.88E-05
1110	8.88E-05	6.31E-05	2.99E-05	2.15E-05
1140	9.22E-05	5.99E-05	3.07E-05	2.06E-05
1170	8.53E-05	5.93E-05	3.17E-05	1.20E-05
1200	7.17E-05	5.84E-05	3.15E-05	2.76E-05
1230	6.72E-05	5.83E-05	2.70E-05	2.20E-05
1260	6.74E-05	5.79E-05	2.55E-05	1.82E-05
1290	6.69E-05	5.79E-05	2.40E-05	2.28E-05
1320	7.50E-05	5.88E-05	2.37E-05	1.78E-05
1350	9.92E-05	4.99E-05	2.67E-05	2.87E-05
1380	1.00E-04	4.84E-05	3.04E-05	2.10E-05
1410	1.02E-04	4.70E-05	2.85E-05	2.37E-05
1440	9.82E-05	5.28E-05	1.77E-05	2.03E-05
1470	9.66E-05	5.81E-05	2.04E-05	1.97E-05
1500	9.64E-05	6.33E-05	2.31E-05	1.25E-05

FLIGHT NO. C-391
TOTAL VOLUME SCATTERING COEFFICIENT

(JOB 4389 DATE 09/30/77)
 DATE 102676 FLIGHT NO. C-391 GROUND LEVEL ALTITUDE (M)= 0

ALTITUDE (M)	TOTAL VOLUME SCATTERING COEFFICIENT (PER M)				
	FILTERS	2	4	3	5
1530		9.73E-05	6.32E-05	3.10E-05	1.66E-05
1560		9.72E-05	6.34E-05	3.14E-05	2.50E-05
1590		9.71E-05	6.34E-05	3.26E-05	2.42E-05
1620		9.65E-05	6.52E-05	3.36E-05	2.34E-05
1650		9.61E-05	6.41E-05	3.34E-05	2.18E-05
1680		9.42E-05	6.37E-05	3.31E-05	1.09E-05
1710		9.34E-05	6.09E-05	3.24E-05	2.08E-05
1740		9.16E-05	4.54E-05	3.23E-05	2.20E-05
1770		8.69E-05	5.58E-05	2.62E-05	2.09E-05
1800		8.52E-05	5.85E-05	2.35E-05	1.59E-05
1830		8.52E-05	5.83E-05	2.32E-05	1.91E-05
1860		8.27E-05	5.83E-05	2.31E-05	1.51E-05
1890		8.17E-05	5.74E-05	2.22E-05	1.71E-05
1920		8.22E-05	5.47E-05	2.63E-05	1.80E-05
1950		7.07E-05	5.35E-05	2.68E-05	1.68E-05
1980		6.59E-05	5.25E-05	2.77E-05	3.07E-05
2010		6.62E-05	5.31E-05	2.59E-05	2.29E-05
2040		8.07E-05	5.62E-05	2.66E-05	1.48E-05
2070		9.69E-05	4.86E-05	2.89E-05	2.60E-05
2100		9.67E-05	4.81E-05	3.14E-05	2.61E-05
2130		9.51E-05	4.62E-05	3.22E-05	2.61E-05
2160		9.30E-05	4.42E-05	3.05E-05	2.70E-05
2190		8.48E-05	4.27E-05	2.95E-05	2.70E-05
2220		8.27E-05	5.55E-05	2.85E-05	2.88E-05
2250		8.18E-05	5.37E-05	2.78E-05	1.71E-05
2280		8.22E-05	4.91E-05	2.70E-05	1.72E-05
2310		7.98E-05	5.39E-05	2.72E-05	1.10E-05
2340		7.94E-05	4.97E-05	2.76E-05	1.29E-05
2370		7.87E-05	5.18E-05	2.78E-05	1.53E-05
2400		7.73E-05	5.25E-05	2.84E-05	1.56E-05
2430		6.92E-05	5.08E-05	2.62E-05	2.70E-05
2460		6.20E-05	5.07E-05	1.88E-05	1.72E-05
2490		6.16E-05	5.08E-05	1.86E-05	1.57E-05
2520		8.63E-05	5.05E-05	2.09E-05	1.98E-05
2550		8.57E-05	5.09E-05	2.47E-05	3.43E-05
2580		8.22E-05	4.42E-05	2.49E-05	3.36E-05
2610		8.32E-05	4.11E-05	2.48E-05	8.34E-06
2640		8.23E-05	3.95E-05	2.47E-05	1.07E-05
2670		8.04E-05	5.85E-05	2.49E-05	1.20E-05
2700		8.05E-05	5.61E-05	2.47E-05	2.16E-05
2730		7.99E-05	5.50E-05	2.45E-05	2.02E-05
2760		7.93E-05	5.34E-05	2.50E-05	2.12E-05
2790		7.73E-05	5.22E-05	2.19E-05	1.38E-05
2820		7.67E-05	5.14E-05	1.68E-05	1.49E-05
2850		7.66E-05	5.09E-05	2.48E-05	1.24E-05
2880		7.56E-05	5.05E-05	2.52E-05	1.93E-05
2910		7.72E-05	5.07E-05	2.51E-05	8.74E-06
2940		6.33E-05	4.99E-05	2.58E-05	1.77E-05
2970		5.96E-05	3.66E-05	2.72E-05	1.84E-05
3000		6.14E-05	3.24E-05	2.26E-05	2.99E-06

FLIGHT NO. C-391
TOTAL VOLUME SCATTERING COEFFICIENT

(JOB 4389 DATE 09/30/77)
 DATE 102676 FLIGHT NO. C-391 GROUND LEVEL ALTITUDE (M)= 0

ALTITUDE (M)	FILTERS	TOTAL VOLUME SCATTERING COEFFICIENT (PER M)			
		2	4	3	5
3030	8.55E-05	3.20E-05	1.81E-05	2.81E-05	
3060	8.28E-05	4.43E-05	1.75E-05	2.44E-05	
3090	8.23E-05	4.54E-05	1.71E-05	2.07E-05	
3120	8.12E-05	4.83E-05	1.73E-05	1.47E-05	
3150	8.13E-05	4.68E-05	2.23E-05	1.32E-05	
3180	7.78E-05	5.05E-05	2.35E-05	1.87E-05	
3210	7.70E-05	4.61E-05	2.38E-05	1.33E-05	
3240	7.56E-05	4.94E-05	2.38E-05	2.23E-05	
3270	7.47E-05	5.05E-05	2.40E-05	2.25E-05	
3300	7.50E-05	4.98E-05	2.38E-05	3.30E-05	
3330	7.52E-05	5.04E-05	2.41E-05	2.13E-05	
3360	7.56E-05	3.89E-05	2.41E-05	2.16E-05	
3390	7.56E-05	3.89E-05	2.42E-05	2.19E-05	
3420	7.47E-05	3.79E-05	2.42E-05	1.30E-05	
3450	6.41E-05	4.61E-05	2.43E-05	9.16E-06	
3480	5.92E-05	5.33E-05	2.45E-05	1.28E-05	
3510	5.91E-05	5.20E-05	2.43E-05	1.51E-05	
3540	5.75E-05	5.16E-05	2.44E-05	1.75E-05	
3570	5.71E-05	5.06E-05	2.46E-05	8.88E-06	
3600	5.76E-05	5.04E-05	2.52E-05	1.68E-05	
3630	8.19E-05	5.07E-05	2.46E-05	1.58E-05	
3660	8.07E-05	4.88E-05	2.50E-05	1.74E-05	
3690	7.96E-05	4.86E-05	2.54E-05	2.16E-05	
3720	7.65E-05	4.48E-05	2.53E-05	1.42E-05	
3750	7.63E-05	3.80E-05	2.58E-05	2.05E-05	
3780	7.59E-05	3.76E-05	1.66E-05	1.54E-05	
3810	7.51E-05	3.76E-05	1.64E-05	1.70E-05	
3840	7.58E-05	3.75E-05	2.00E-05	1.23E-05	
3870	7.64E-05	5.23E-05	2.35E-05	1.01E-05	
3900	7.47E-05	5.10E-05	2.34E-05	1.83E-05	
3930	7.55E-05	5.00E-05	2.33E-05	1.42E-05	
3960	7.42E-05	5.07E-05	2.31E-05	1.02E-05	
3990	7.50E-05	1.29E-05	2.34E-05	1.44E-05	
4020	7.44E-05	5.05E-05	2.33E-05	1.20E-05	
4050	6.50E-05	5.03E-05	2.27E-05	1.07E-05	
4080	5.87E-05	5.01E-05	2.25E-05	1.78E-05	
4110	6.42E-05	4.40E-05	2.18E-05	1.86E-05	
4140	6.97E-05	3.79E-05	2.22E-05	1.13E-05	
4170	8.12E-05	3.74E-05	2.34E-05	1.62E-05	
4200	8.03E-05	3.70E-05	2.35E-05	1.91E-05	
4230	7.65E-05	3.66E-05	2.36E-05	1.55E-05	
4260	7.60E-05	4.24E-05	2.36E-05	1.87E-05	
4290	7.54E-05	4.83E-05	2.38E-05	1.77E-05	
4320	7.56E-05	5.05E-05	2.42E-05	2.26E-05	
4350	7.43E-05	4.98E-05	2.40E-05	1.73E-05	
4380	7.48E-05	2.78E-05	2.41E-05	1.48E-05	
4410	5.79E-05	4.84E-05	2.44E-05	1.03E-05	
4440	5.74E-05	2.47E-05	2.51E-05	1.68E-05	
4470	5.72E-05	4.86E-05	2.48E-05	1.38E-05	
4500	5.59E-05	4.50E-05	2.52E-05	1.74E-05	

FLIGHT NO. C-391
TOTAL VOLUME SCATTERING COEFFICIENT

(JOB 4389 DATE 09/30/77)
 DATE 102676 FLIGHT NO. C-391 GROUND LEVEL ALTITUDE (M)= 0

ALTITUDE (M)	FILTERS	TOTAL VOLUME SCATTERING COEFFICIENT (PER M)			
		2	4	3	5
4530	8.14E-05	3.60E-05	2.60E-05	1.65E-05	
4560	7.71E-05	1.96E-05	1.73E-05	1.70E-05	
4590	7.64E-05	3.46E-05	1.62E-05	1.74E-05	
4620	7.58E-05	3.42E-05	1.62E-05	1.78E-05	
4650	7.29E-05	4.17E-05	1.61E-05	1.91E-05	
4680	7.27E-05	4.92E-05	2.01E-05	1.96E-05	
4710	7.11E-05	4.90E-05	2.11E-05	1.70E-05	
4740	6.95E-05	4.72E-05	2.20E-05	1.84E-05	
4770	5.62E-05	4.78E-05	2.26E-05	1.83E-05	
4800	5.51E-05	4.77E-05	2.26E-05	2.03E-05	
4830	5.81E-05	4.72E-05	2.26E-05	1.78E-05	
4860	6.69E-05	4.61E-05	2.27E-05	1.52E-05	
4890	7.56E-05	4.57E-05	2.29E-05	1.27E-05	
4920	7.50E-05	3.40E-05	2.27E-05	1.34E-05	
4950	7.29E-05	3.45E-05	2.23E-05	1.69E-05	
4980	7.30E-05	3.82E-05	2.27E-05	1.67E-05	
5010	7.10E-05	5.07E-05	2.30E-05	1.67E-05	
5040	7.15E-05	4.90E-05	2.31E-05	1.67E-05	
5070	7.15E-05	4.81E-05	2.32E-05	1.92E-05	
5100	7.02E-05	4.79E-05	2.31E-05	(1.92E-05)	
5130	7.07E-05	4.42E-05	2.22E-05	(1.91E-05)	
5160	5.42E-05	4.61E-05	2.32E-05	(1.90E-05)	
5190	5.42E-05	(4.59E-05)	2.36E-05	(1.90E-05)	
5220	6.49E-05	(4.58E-05)	2.34E-05	(1.89E-05)	
5250	7.56E-05	(4.56E-05)	2.32E-05	(1.89E-05)	
5280	7.54E-05	(4.55E-05)	2.36E-05	(1.88E-05)	
5310	7.40E-05	(4.53E-05)	2.32E-05	(1.88E-05)	
5340	7.25E-05	(4.52E-05)	2.37E-05	(1.87E-05)	
5370	7.18E-05	(4.51E-05)	2.39E-05	(1.86E-05)	
5400	7.08E-05	(4.49E-05)	2.47E-05	(1.86E-05)	
5430	7.02E-05	(4.48E-05)	1.91E-05	(1.85E-05)	
5460	6.49E-05	(4.46E-05)	(1.91E-05)	(1.85E-05)	
5490	5.96E-05	(4.45E-05)	(1.90E-05)	(1.84E-05)	
5520	(5.94E-05)	(4.44E-05)	(1.90E-05)	(1.83E-05)	
5550	(5.92E-05)	(4.42E-05)	(1.89E-05)	(1.83E-05)	
5580	(5.90E-05)	(4.41E-05)	(1.88E-05)	(1.82E-05)	
5610	(5.88E-05)	(4.39E-05)	(1.88E-05)	(1.82E-05)	
5640	(5.86E-05)	(4.38E-05)	(1.87E-05)	(1.81E-05)	
5670	(5.84E-05)	(4.37E-05)	(1.87E-05)	(1.81E-05)	
5700	(5.82E-05)	(4.35E-05)	(1.86E-05)	(1.80E-05)	
FIRST DATA ALT	270	300	330	870	
LAST DATA ALT	5490	5160	5430	5070	

FLIGHT NO. C-391 EQUIVALENT ATTENUATION LENGTH

(JOB 4389 DATE 09/30/77)
DATE 102676 FLIGHT NO. C-391 GROUND LEVEL ALTITUDE (M)= 0

ALTITUDE (M)	EQUIVALENT ATTENUATION LENGTH (M)			
	FILTERS	2	4	3
0	8.33E 02	9.60E 02	1.20E 03	1.32E 03
300	8.46E 02	9.75E 02	1.21E 03	1.34E 03
600	8.65E 02	9.88E 02	1.21E 03	1.35E 03
900	9.60E 02	1.21E 03	1.39E 03	1.51E 03
1200	1.24E 03	1.58E 03	1.83E 03	2.00E 03
1500	1.51E 03	1.93E 03	2.26E 03	2.47E 03
1800	1.77E 03	2.26E 03	2.68E 03	2.93E 03
2100	2.01E 03	2.59E 03	3.09E 03	3.39E 03
2400	2.25E 03	2.90E 03	3.48E 03	3.83E 03
2700	2.47E 03	3.21E 03	3.88E 03	4.27E 03
3000	2.69E 03	3.50E 03	4.27E 03	4.71E 03
3300	2.90E 03	3.79E 03	4.65E 03	5.14E 03
3600	3.11E 03	4.07E 03	5.02E 03	5.56E 03
3900	3.30E 03	4.35E 03	5.39E 03	5.98E 03
4200	3.49E 03	4.61E 03	5.75E 03	6.39E 03
4500	3.68E 03	4.88E 03	6.10E 03	6.80E 03
4800	3.86E 03	5.13E 03	6.45E 03	7.19E 03
5100	4.03E 03	5.38E 03	6.79E 03	7.59E 03
5400	4.20E 03	5.61E 03	7.13E 03	7.97E 03
5700	4.37E 03	5.84E 03	7.47E 03	8.34E 03

FLIGHT NO. C-391 VERTICAL BEAM TRANSMITTANCE FROM GROUND TO ALTITUDE

ALTITUDE (M)	VERTICAL BEAM TRANSMITTANCE FROM GROUND TO ALTITUDE			
	FILTERS	2	4	3
0	1.00E 00	1.00E 00	1.00E 00	1.00E 00
300	7.01E-01	7.35E-01	7.81E-01	7.99E-01
600	5.00E-01	5.45E-01	6.09E-01	6.42E-01
900	3.91E-01	4.75E-01	5.24E-01	5.51E-01
1200	3.81E-01	4.67E-01	5.19E-01	5.48E-01
1500	3.71E-01	4.60E-01	5.15E-01	5.44E-01
1800	3.61E-01	4.51E-01	5.10E-01	5.41E-01
2100	3.52E-01	4.44E-01	5.06E-01	5.38E-01
2400	3.43E-01	4.37E-01	5.02E-01	5.35E-01
2700	3.36E-01	4.31E-01	4.99E-01	5.32E-01
3000	3.28E-01	4.25E-01	4.95E-01	5.29E-01
3300	3.21E-01	4.19E-01	4.92E-01	5.26E-01
3600	3.14E-01	4.13E-01	4.88E-01	5.23E-01
3900	3.07E-01	4.08E-01	4.85E-01	5.21E-01
4200	3.01E-01	4.02E-01	4.82E-01	5.19E-01
4500	2.94E-01	3.97E-01	4.78E-01	5.16E-01
4800	2.88E-01	3.93E-01	4.75E-01	5.13E-01
5100	2.82E-01	3.87E-01	4.72E-01	5.11E-01
5400	2.77E-01	3.82E-01	4.69E-01	5.08E-01
5700	2.72E-01	3.77E-01	4.66E-01	5.05E-01

FLIGHT C-392 – 1 NOVEMBER 1976 – DESCRIPTION OF FLIGHT AND WEATHER CHARACTERISTICS

Filter Ident	Data Interval			Solar Zenith Angle			Flight Altitude (meters)		Average Terrain Elevation (meters)
	Start (GMT)	End (GMT)	Elapsed (hrs) (min)	Initial (degrees)	Solar Transit (degrees)	Final (degrees)	(min)	(max)	
2,3	1115	1208	0 53	67.6	–	68.6	420	1410	18
4,5	1212	1253	0 41	68.7	–	71.0	360	1170	18

Flight C-392 was an afternoon flight. Multiple cloud layers varied from broken to overcast.

The approximate northeast to southwest Meppen track was located between Oldenburg and Lathen in northwestern Germany. Typical terrain features were heavily cultivated low lying flat farmlands interspersed with occasional dark woods and small towns.

The inflight observer reported scattered clouds at 1500 meters (5000 feet), 7/8 altocumulus at 5400 meters (18000 feet), 7/8 cirrus at 6000 meters (20000 feet). By 1345 GMT the lower clouds were scattered to broken at 2100 meters (7000 feet), the altocumulus was unchanged and the cirrus had increased to overcast. Conditions worsened at the east end with the lower broken layer having tops of 2400 meters (8000 feet) and increasing to overcast by 1412 GMT. Moderate haze was observed throughout the track and the period.

Twente, west of the track, reported 1/8 stratocumulus at 1500 meters (5000 feet) and 7/8 altocumulus at 2400 meters (8000 feet) at 1000 and 1100 GMT. The stratocumulus lowered to 750 meters (2500 feet) by 1200 GMT and the altocumulus raised to 3600 meters (12000 feet). By 1229 GMT the stratocumulus increased to 6/8 coverage at 630 meters (2100 feet) and gradually lowered to 540 meters (1800 feet) by 1400 GMT. The altocumulus layer increased to overcast and gradually lowered to 2700 meters (9000 feet) through the afternoon. Visibility was 6 to 8 kilometers in haze.

Lingen, south of the track, reported 5/8 stratocumulus at 1200 meters (4000 feet) and 6/8 altocumulus at 2700 meters (9000 feet) with visibility 4.2 kilometers in light fog at 1100 GMT. Conditions improved to 3/8 cumulus and stratocumulus at 450 meters (1500 feet), 5/8 altocumulus at 3000 meters (10000 feet), visibility 7 to 8 kilometers in haze. At 1500 GMT there was 5/8 stratocumulus at 750 meters (2500 feet), overcast altocumulus at 2700 meters (9000 feet) and visibility 10 kilometers.

Oldenburg and Ahlhorn, east of the track, include ceiling and visibility data in their reports but no cloud types or amounts. At Oldenburg the ceilings were reported from 1200 to 1500 meters (4000 to 5000 feet) and visibility 5 to 7 kilometers with haze. Ahlhorn reported ceilings 1500 to 2700 meters (5000 to 9000 feet) and visibility 6 to 7 kilometers in haze.

The radiosonde station at Rheine/Waldhugel was approximately 81 kilometers south of the flight track center point, but no data were taken on this date.

The surface chart for 1200 GMT had a weak ridge with its axis through eastern Germany. From a 960-millibar low centered south of Iceland an occlusion extended east and south-southeast through the western part of the North Sea then as a cold front south and south-southwest through western France and northwestern Spain and Portugal into the Atlantic. At 500 millibars there was a low over western Finland. A weak gradient prevailed over western Europe with light to moderate westerly winds. The airmass was stable maritime polar.

FLIGHT NO. C-392

MEPPEN

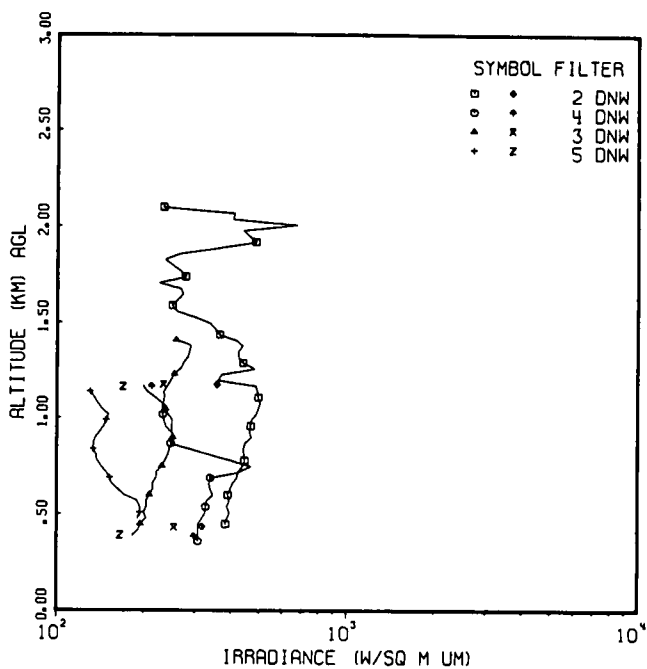
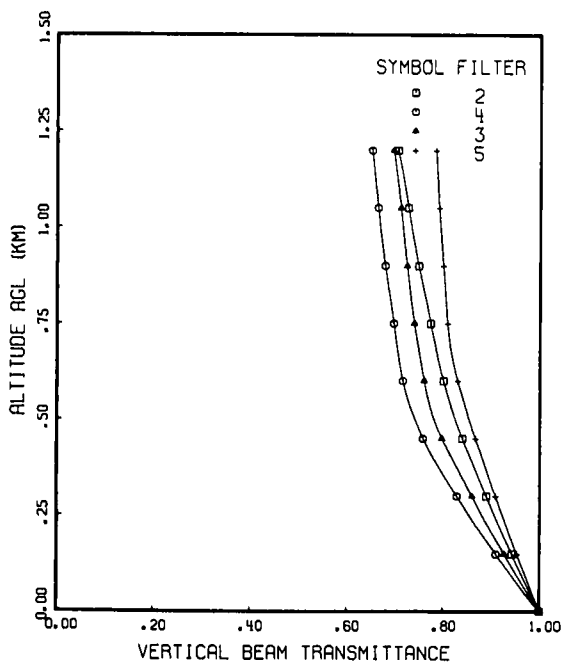
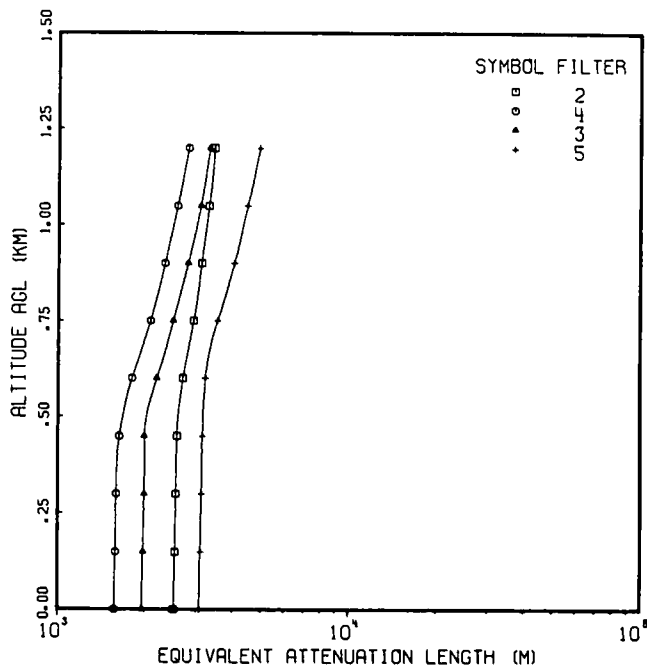
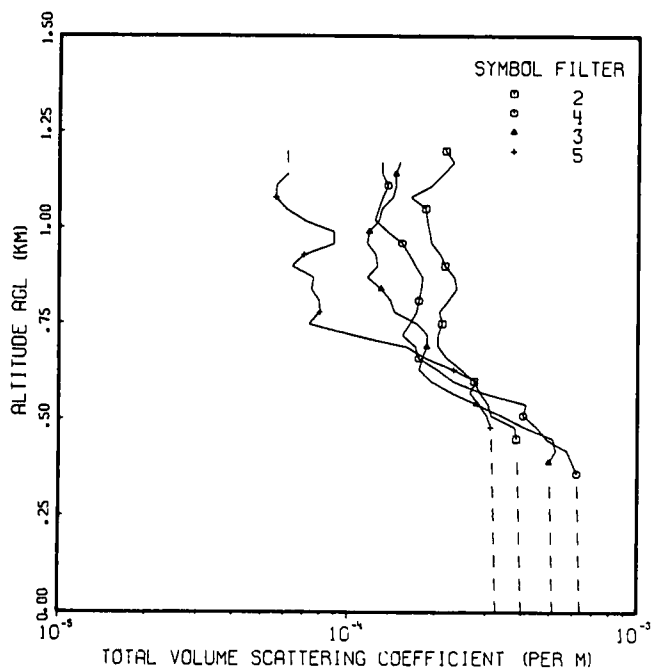

FLIGHT NO. C-392
TOTAL VOLUME SCATTERING COEFFICIENT

(JOB 4341 DATE 06/23/77)
 DATE 110176 FLIGHT NO. C-392 GROUND LEVEL ALTITUDE (M)= 18

ALTITUDE (M)	TOTAL VOLUME SCATTERING COEFFICIENT (PER M)			
	FILTERS	2	4	3
0	(3.98E-04)	(6.38E-04)	(5.12E-04)	(3.25E-04)
30	(3.96E-04)	(6.35E-04)	(5.09E-04)	(3.23E-04)
60	(3.95E-04)	(6.33E-04)	(5.08E-04)	(3.23E-04)
90	(3.94E-04)	(6.32E-04)	(5.07E-04)	(3.22E-04)
120	(3.93E-04)	(6.30E-04)	(5.06E-04)	(3.21E-04)
150	(3.92E-04)	(6.28E-04)	(5.04E-04)	(3.20E-04)
180	(3.91E-04)	(6.27E-04)	(5.03E-04)	(3.19E-04)
210	(3.90E-04)	(6.25E-04)	(5.02E-04)	(3.19E-04)
240	(3.89E-04)	(6.23E-04)	(5.00E-04)	(3.18E-04)
270	(3.88E-04)	(6.22E-04)	(4.99E-04)	(3.17E-04)
300	(3.87E-04)	(6.20E-04)	(4.98E-04)	(3.16E-04)
330	(3.86E-04)	(6.19E-04)	(4.96E-04)	(3.15E-04)
360	(3.85E-04)	6.17E-04	(4.95E-04)	(3.14E-04)
390	(3.84E-04)	5.93E-04	4.94E-04	(3.14E-04)
420	(3.83E-04)	5.70E-04	5.22E-04	(3.13E-04)
450	3.82E-04	4.83E-04	5.11E-04	(3.12E-04)
480	3.76E-04	4.48E-04	4.07E-04	3.11E-04
510	3.11E-04	4.02E-04	3.38E-04	3.01E-04
540	3.04E-04	4.12E-04	2.77E-04	2.81E-04
570	2.85E-04	2.90E-04	2.27E-04	2.63E-04
600	2.72E-04	2.29E-04	1.92E-04	2.77E-04
630	2.45E-04	2.03E-04	1.76E-04	2.31E-04
660	2.19E-04	1.75E-04	1.80E-04	1.85E-04
690	2.04E-04	1.70E-04	1.86E-04	1.58E-04
720	2.04E-04	1.54E-04	1.87E-04	1.04E-04
750	2.10E-04	1.63E-04	1.72E-04	7.31E-05
780	2.06E-04	1.71E-04	1.43E-04	7.94E-05
810	2.21E-04	1.75E-04	1.39E-04	7.86E-05
840	2.36E-04	1.78E-04	1.29E-04	7.41E-05
870	2.32E-04	1.80E-04	1.16E-04	7.52E-05
900	2.15E-04	1.70E-04	1.26E-04	6.37E-05
930	2.07E-04	1.62E-04	1.24E-04	7.00E-05
960	1.92E-04	1.53E-04	1.15E-04	8.89E-05
990	1.89E-04	1.36E-04	1.17E-04	8.88E-05
1020	1.86E-04	1.23E-04	1.27E-04	7.00E-05
1050	1.84E-04	1.27E-04	1.30E-04	6.06E-05
1080	1.64E-04	1.31E-04	1.42E-04	5.58E-05
1110	1.94E-04	1.36E-04	1.45E-04	5.60E-05
1140	2.12E-04	1.30E-04	1.45E-04	6.15E-05
1170	2.30E-04	1.30E-04	1.50E-04	(6.13E-05)
1200	2.16E-04	(1.30E-04)	(1.50E-04)	(6.11E-05)
FIRST DATA ALT	450	360	390	480
LAST DATA ALT	1200	1170	1170	1140

FLIGHT NO. C-392
EQUIVALENT ATTENUATION LENGTH

(JOB 4341 DATE 06/23/77)
 DATE 110176 FLIGHT NO. C-392 GROUND LEVEL ALTITUDE (M)= 18

ALTITUDE (M)	EQUIVALENT ATTENUATION LENGTH (M)			
	FILTERS 2	4	3	5
0	2.51E 03	1.57E 03	1.95E 03	3.08E 03
300	2.55E 03	1.59E 03	1.98E 03	3.12E 03
600	2.69E 03	1.80E 03	2.18E 03	3.21E 03
900	3.11E 03	2.32E 03	2.79E 03	4.03E 03
1200	3.44E 03	2.80E 03	3.31E 03	4.92E 03

FLIGHT NO. C-392
VERTICAL BEAM TRANSMITTANCE FROM GROUND TO ALTITUDE

ALTITUDE (M)	VERTICAL BEAM TRANSMITTANCE FROM GROUND TO ALTITUDE			
	FILTERS 2	4	3	5
0	1.00E 00	1.00E 00	1.00E 00	1.00E 00
300	8.89E-01	9.28E-01	8.60E-01	9.08E-01
600	8.00E-01	7.16E-01	7.60E-01	8.30E-01
900	7.48E-01	6.79E-01	7.24E-01	8.00E-01
1200	7.05E-01	6.51E-01	6.96E-01	7.84E-01

FLIGHT C-393 – 2 NOVEMBER 1976 – DESCRIPTION OF FLIGHT AND WEATHER CHARACTERISTICS

Filter Ident	Data Interval			Solar Zenith Angle			Flight Altitude (meters)		Average Terrain Elevation (meters)
	Start (GMT)	End (GMT)	Elapsed (hrs) (min)	Initial (degrees)	Solar Transit (degrees)	Final (degrees)	(min)	(max)	
2	1036	1046	0 10	68 3	—	68 1	300	1590	18
3	1050	1053	0 3	68 0	—	68 0	270	1440	18
4	1108	1111	0 3	67 9	—	67 9	360	1380	18
5	1114	1117	0 3	67 9	—	67 9	330	1440	18

Flight C-393 was a midday flight spanning local apparent noon. Multiple cloud layers varied from broken to overcast. Light rain occurred after 1200 GMT.

The approximate northeast to southwest Meppen track was located between Oldenburg and Lathen in northwestern Germany. Typical terrain features were heavily cultivated low lying flat farmlands interspersed with occasional dark woods and small towns.

The in-flight observer reported initial conditions of 450 meters (1500 feet) scattered stratocumulus, 2400 meters (8000 feet) broken altostratus and overcast cirrus at the east end of the track. At the west end there were 450 meters (1500 feet) scattered stratocumulus and 1500 meters (5000 feet) overcast altostratus. At the end of the period the east end had 450 meters (1500 feet) scattered, 1500 meters (5000 feet) overcast, the west end was scattered variable broken stratocumulus at 450 meters (1500 feet) and overcast altostratus at 1500 meters (5000 feet). Along the track the 450-meter (1500 foot) deck was variably scattered to broken.

Lingen, south of the track, reported 6/8 cumulus at 450 meters (1500 feet) at 0900 GMT. The ceiling gradually improved to 1140 meters (3800 feet) by 1100 GMT and the low layer of clouds decreased to 4/8 at 1050 meters (3500 feet) at 1200 GMT. A 7/8 layer of altocumulus at 3300 meters (11000 feet) was reported at 1200 GMT and 6/8 altocumulus at 1800 meters (6000 feet) was observed at 1300 GMT. Visibilities ranged from 12 to 18 kilometers with very light rain after 1200 GMT.

Twente west of the track, reported 4/8 cumulus and stratocumulus at 450 meters (1500 feet), 6/8 to 8/8 thin altocumulus at 3600 meters (12000 feet) through the morning. At 1200 GMT the altocumulus layer had thickened and was at 2700 meters (9000 feet). Visibilities were 8 to 10 kilometers with light fog and light rain.

Oldenburg and Ahlhorn, east of the track, include ceiling and visibility data in their reports but no cloud types or amounts. At Oldenburg the ceiling data indicated variable amounts of lower clouds at 600 to 1200 meters (2000 to 4000 feet) and visibility 8 to 11.2 kilometers. At Ahlhorn the low layer was 1200 to 1350 meters (4000 to 4500 feet) with visibility 11.2 km.

The radiosonde station at Rheine/Waldhugel was approximately 81 kilometers south and upstream of the flight track center point.

On the 1200 GMT surface chart a 972-millibar low southeast of Iceland was filling and moving slowly eastward. A rapidly moving occlusion was along Göteborg-Szczecin-Bayreuth-Turin-Cordoba line and southwesterly to the Atlantic. A trough line paralleled the front from the North Sea to Haarlem-Gent-Paris line. At 500 millibars there was weak ridging over Poland and troughing over Ireland with moderate west-southwesterly flow. The airmass was unstable maritime polar.

FLIGHT NO. C-393

MEPPEN

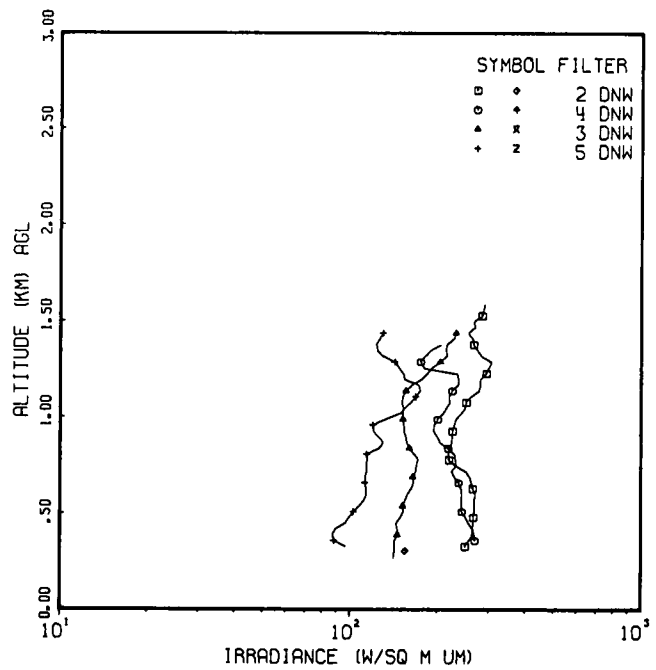
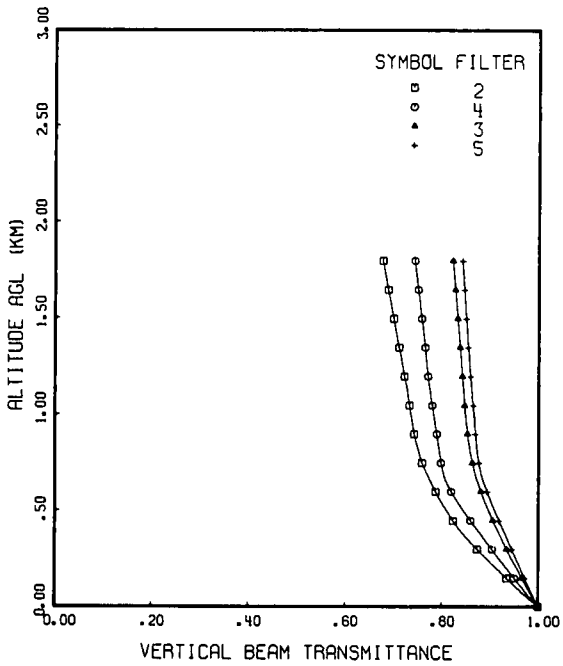
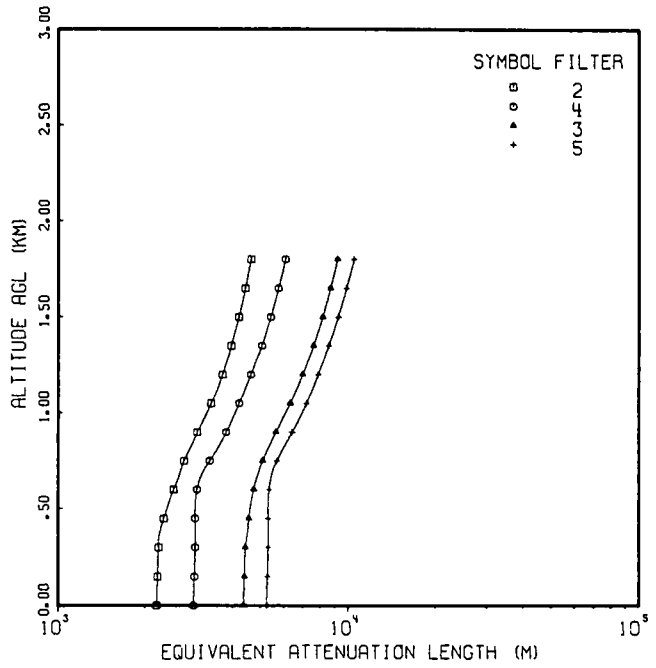
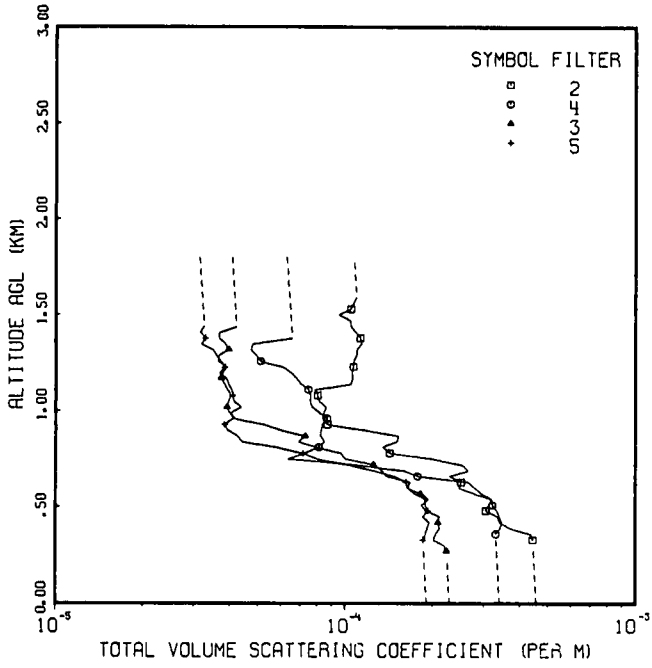

FLIGHT NO. C-393

TOTAL VOLUME SCATTERING COEFFICIENT

{JOB 4340 DATE 06/24/77}
 DATE 110276 FLIGHT NO. C-393 GROUND LEVEL ALTITUDE (M)= 18

ALTITUDE (M)	TOTAL VOLUME SCATTERING COEFFICIENT (PER M)			
	FILTERS	2	4	3
0	(4.57E-04)	(3.42E-04)	(2.30E-04)	(1.91E-04)
30	(4.55E-04)	(3.40E-04)	(2.29E-04)	(1.90E-04)
60	(4.54E-04)	(3.39E-04)	(2.28E-04)	(1.90E-04)
90	(4.53E-04)	(3.38E-04)	(2.27E-04)	(1.89E-04)
120	(4.51E-04)	(3.37E-04)	(2.27E-04)	(1.89E-04)
150	(4.50E-04)	(3.37E-04)	(2.26E-04)	(1.88E-04)
180	(4.49E-04)	(3.36E-04)	(2.26E-04)	(1.88E-04)
210	(4.48E-04)	(3.35E-04)	(2.25E-04)	(1.87E-04)
240	(4.47E-04)	(3.34E-04)	(2.24E-04)	(1.87E-04)
270	(4.46E-04)	(3.33E-04)	2.24E-04	(1.86E-04)
300	(4.44E-04)	(3.32E-04)	2.19E-04	(1.86E-04)
330	4.43E-04	(3.31E-04)	2.01E-04	1.85E-04
360	4.37E-04	3.30E-04	2.05E-04	1.90E-04
390	3.69E-04	3.42E-04	2.11E-04	1.91E-04
420	3.41E-04	3.48E-04	2.08E-04	1.95E-04
450	3.34E-04	3.40E-04	2.11E-04	1.85E-04
480	3.06E-04	3.33E-04	1.90E-04	1.93E-04
510	3.13E-04	3.22E-04	1.83E-04	1.89E-04
540	3.20E-04	3.20E-04	1.93E-04	1.88E-04
570	2.78E-04	2.94E-04	1.82E-04	1.73E-04
600	2.46E-04	2.79E-04	1.64E-04	1.63E-04
630	2.51E-04	2.64E-04	1.67E-04	1.62E-04
660	2.28E-04	1.77E-04	1.39E-04	1.47E-04
690	2.66E-04	1.58E-04	1.33E-04	1.25E-04
720	2.52E-04	1.09E-04	1.25E-04	1.01E-04
750	1.99E-04	6.32E-05	9.96E-05	7.95E-05
780	1.42E-04	7.20E-05	9.65E-05	7.13E-05
810	1.34E-04	8.09E-05	7.93E-05	5.83E-05
840	1.51E-04	8.46E-05	6.88E-05	4.39E-05
870	1.52E-04	8.21E-05	7.26E-05	4.24E-05
900	1.16E-04	8.26E-05	6.00E-05	3.91E-05
930	8.65E-05	8.31E-05	5.22E-05	3.82E-05
960	8.33E-05	8.65E-05	4.15E-05	4.10E-05
990	8.41E-05	8.11E-05	3.97E-05	4.03E-05
1020	8.57E-05	7.67E-05	3.90E-05	4.37E-05
1050	8.13E-05	7.56E-05	3.95E-05	4.12E-05
1080	8.03E-05	7.59E-05	4.03E-05	4.08E-05
1110	7.84E-05	7.44E-05	3.91E-05	4.05E-05
1140	1.04E-04	7.03E-05	3.82E-05	3.94E-05
1170	1.06E-04	6.77E-05	3.72E-05	3.88E-05
1200	1.06E-04	6.47E-05	3.77E-05	3.67E-05
1230	1.07E-04	6.07E-05	3.88E-05	3.83E-05
1260	1.07E-04	5.09E-05	3.63E-05	3.71E-05
1290	1.09E-04	4.91E-05	3.66E-05	3.58E-05
1320	1.09E-04	4.72E-05	3.95E-05	3.48E-05
1350	1.13E-04	4.78E-05	3.84E-05	3.18E-05
1380	1.13E-04	6.54E-05	3.66E-05	3.29E-05
1410	1.08E-04	(6.52E-05)	3.67E-05	3.15E-05
1440	1.04E-04	(6.50E-05)	4.20E-05	3.25E-05
1470	1.04E-04	(6.48E-05)	(4.19E-05)	(3.24E-05)
1500	9.47E-05	(6.46E-05)	(4.18E-05)	(3.23E-05)
1530	1.04E-04	(6.44E-05)	(4.16E-05)	(3.22E-05)
1560	1.07E-04	(6.42E-05)	(4.15E-05)	(3.21E-05)
1590	1.09E-04	(6.40E-05)	(4.14E-05)	(3.20E-05)
1620	(1.09E-04)	(6.38E-05)	(4.12E-05)	(3.19E-05)
1650	(1.08E-04)	(6.36E-05)	(4.11E-05)	(3.18E-05)
1680	(1.08E-04)	(6.34E-05)	(4.10E-05)	(3.17E-05)
1710	(1.08E-04)	(6.32E-05)	(4.09E-05)	(3.16E-05)
1740	(1.07E-04)	(6.30E-05)	(4.07E-05)	(3.15E-05)
1770	(1.07E-04)	(6.28E-05)	(4.06E-05)	(3.14E-05)
1800	(1.07E-04)	(6.26E-05)	(4.05E-05)	(3.13E-05)

FIRST DATA ALT 330 360 270 330
 LAST DATA ALT 1590 1380 1440 1440

FLIGHT NO. C-393
EQUIVALENT ATTENUATION LENGTH

(JOB 4340 DATE 06/24/77)
 DATE 110276 FLIGHT NO. C-393 GROUND LEVEL ALTITUDE (M)= 18

ALTITUDE (M)	EQUIVALENT ATTENUATION LENGTH (M)			
	FILTERS 2	4	3	5
0	2.19E 03	2.93E 03	4.35E 03	5.23E 03
300	2.22E 03	2.97E 03	4.42E 03	5.31E 03
600	2.50E 03	3.01E 03	4.72E 03	5.34E 03
900	3.02E 03	3.79E 03	5.63E 03	6.41E 03
1200	3.69E 03	4.61E 03	6.96E 03	7.87E 03
1500	4.19E 03	5.40E 03	8.16E 03	9.22E 03
1800	4.62E 03	6.07E 03	9.17E 03	1.05E 04

FLIGHT NO. C-393
VERTICAL BEAM TRANSMITTANCE FROM GROUND TO ALTITUDE

ALTITUDE (M)	VERTICAL BEAM TRANSMITTANCE FROM GROUND TO ALTITUDE			
	FILTERS 2	4	3	5
0	1.00E 00	1.00E 00	1.00E 00	1.00E 00
300	8.74E-01	9.04E-01	9.34E-01	9.45E-01
600	7.87E-01	8.20E-01	8.81E-01	8.94E-01
900	7.42E-01	7.89E-01	8.52E-01	8.69E-01
1200	7.22E-01	7.71E-01	8.42E-01	8.59E-01
1500	6.99E-01	7.58E-01	8.32E-01	8.50E-01
1800	6.77E-01	7.43E-01	8.22E-01	8.42E-01

FLIGHT C-394 – 18 NOVEMBER 1976 – DESCRIPTION OF FLIGHT AND WEATHER CHARACTERISTICS

Filter Ident	Data Interval			Solar Zenith Angle			Flight Altitude (meters)		Average Terrain Elevation (meters)
	Start (GMT)	End (GMT)	Elapsed (hrs) (min)	Initial (degrees)	Solar Transit (degrees)	Final (degrees)	(min)	(max)	
2,3	1147	1221	0 34	74.7	–	76.0	210	900	0
4,5	1225	1259	0 34	76.2	–	76.2	300	900	0

Flight C-394 was an afternoon flight commencing slightly after local noon. There was a solid deck of low clouds along the flight path.

The approximate north to south Rodby track was located along the east shore of Langeland Island, Denmark. Typical terrain features along the nearby coast west of the track were flat cultivated farmlands interspersed with occasional woods and small towns. Directly beneath the track and to the east were the relatively shallow waters of Langeland Bay.

The in-flight observer reported overcast stratocumulus with bases 1050 to 1200 meters (3500 to 4000 feet) and overcast cirrostratus at 6600 meters (22 000 feet). The visibility was 5 miles in haze. The haze thickened at the extreme southern end of the track and the flight line was moved 10 miles farther north. The observer reported overcast stratocumulus with bases at 1050 meters (3500 feet) on this alternate flight track.

At Fehmarnbelt, southeast of the track, overcast stratocumulus were reported at 990 meters (3300 feet) and visibility of 20 kilometers at 0900 GMT decreased to 10 kilometers by 1200 GMT.

Kegnaes, west of the track, reported overcast cumulus and stratocumulus at 660 meters (2200 feet) at 0900 GMT and at 750 meters (2500 feet) at 1200 GMT. By 1500 GMT the lower layer was absent and there was 5/8 cirrus at 6000 meters (20 000 feet). Visibility varied from 6 to 8 kilometers in light fog.

The radiosonde station at Schleswig was approximately 106 kilometers west of the flight track center point on a line that ran crosswind to the prevailing airflow.

At 1200 GMT the surface chart showed a high centered over Scotland that covered Britain and the Scandinavian peninsula. Widespread ground fog and cumulus with stratocumulus were charted over Scandinavia and eastern Europe. There was also a filling low in Sicily with a cold front extending into Libya. At 500 millibars there was a low over eastern Poland with a weak gradient over western Europe. Light to moderate northwest to north flow was over the flight region. The airmass was stable maritime polar.

FLIGHT NO. C-394

RODBY

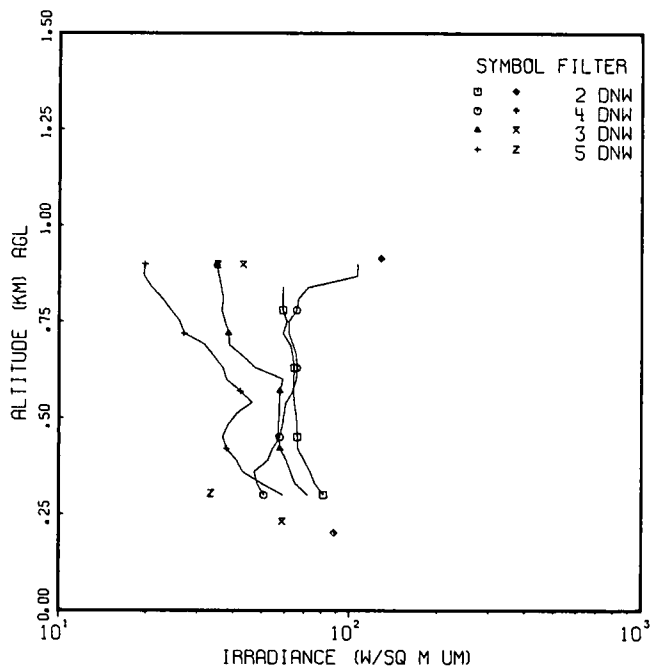
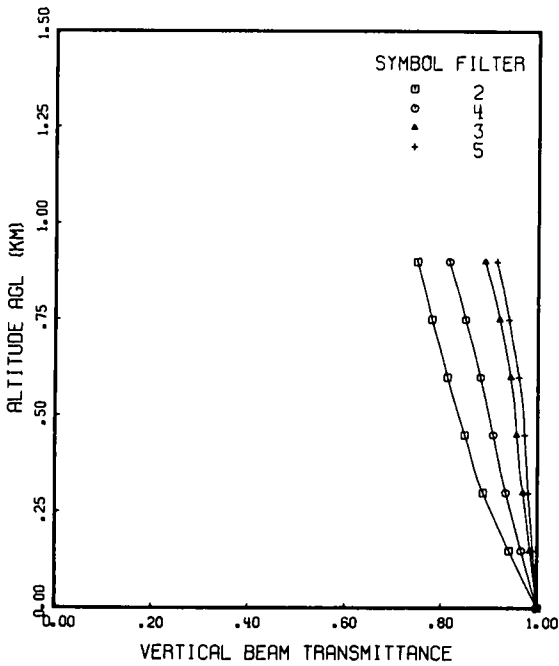
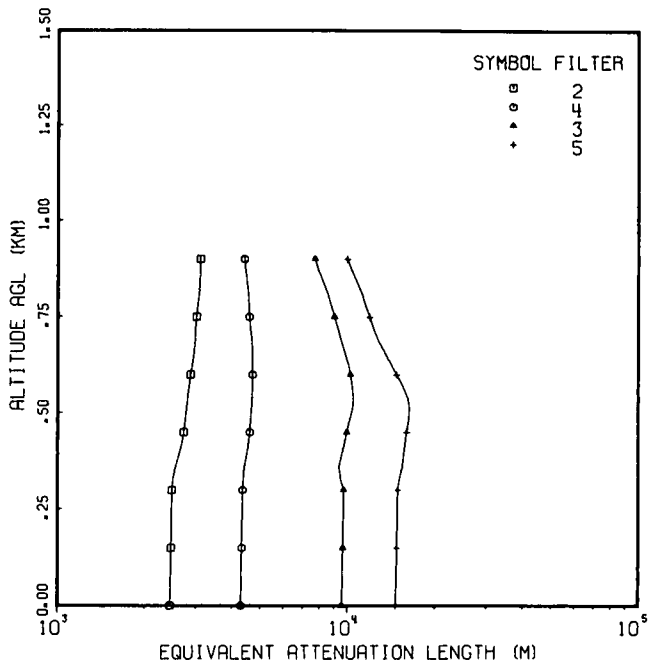
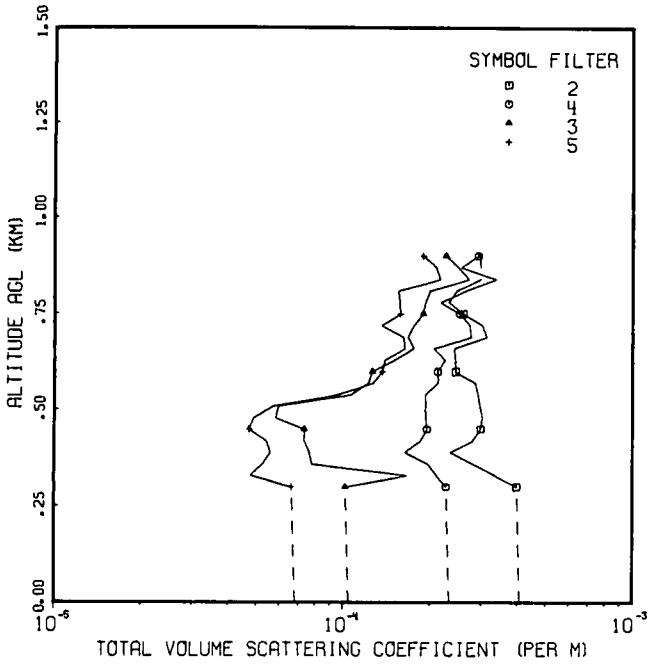

FLIGHT NO. C-394
TOTAL VOLUME SCATTERING COEFFICIENT

(JOB 5506 DATE 09/23/77)
 DATE 111876 FLIGHT NO. C-394 GROUND LEVEL ALTITUDE (M)= 0

ALTITUDE (M)	FILTERS	TOTAL VOLUME SCATTERING COEFFICIENT (PER M)			
		2	4	3	5
0		(4.08E-04)	(2.33E-04)	(1.04E-04)	(6.81E-05)
30		(4.06E-04)	(2.32E-04)	(1.04E-04)	(6.78E-05)
60		(4.05E-04)	(2.31E-04)	(1.04E-04)	(6.76E-05)
90		(4.04E-04)	(2.31E-04)	(1.03E-04)	(6.74E-05)
120		(4.03E-04)	(2.30E-04)	(1.03E-04)	(6.73E-05)
150		(4.02E-04)	(2.29E-04)	(1.03E-04)	(6.71E-05)
180		(4.01E-04)	(2.29E-04)	(1.03E-04)	(6.69E-05)
210		(4.00E-04)	(2.28E-04)	(1.02E-04)	(6.68E-05)
240		(3.99E-04)	(2.28E-04)	(1.02E-04)	(6.66E-05)
270		(3.98E-04)	(2.27E-04)	(1.02E-04)	(6.64E-05)
300		3.97E-04	2.26E-04	1.02E-04	6.62E-05
330		3.34E-04	2.09E-04	1.66E-04	4.79E-05
360		2.80E-04	1.96E-04	7.76E-05	5.27E-05
390		2.35E-04	1.63E-04	7.63E-05	5.60E-05
420		2.79E-04	1.85E-04	7.31E-05	5.41E-05
450		2.98E-04	1.95E-04	7.34E-05	4.72E-05
480		3.02E-04	1.92E-04	5.85E-05	4.91E-05
510		2.97E-04	1.92E-04	5.96E-05	5.72E-05
540		2.92E-04	1.92E-04	1.06E-04	9.49E-05
570		2.86E-04	2.12E-04	1.22E-04	1.27E-04
600		2.44E-04	2.12E-04	1.26E-04	1.36E-04
630		2.43E-04	2.24E-04	1.50E-04	1.39E-04
660		2.41E-04	2.06E-04	1.75E-04	1.63E-04
690		3.13E-04	2.76E-04	1.67E-04	1.61E-04
720		3.02E-04	2.73E-04	1.75E-04	1.35E-04
750		2.59E-04	2.52E-04	1.89E-04	1.57E-04
780		2.31E-04	2.16E-04	1.92E-04	1.56E-04
810		2.46E-04	2.63E-04	1.99E-04	1.55E-04
840		2.97E-04	3.36E-04	2.71E-04	2.15E-04
870		(2.97E-04)	2.56E-04	2.48E-04	2.09E-04
900		(2.96E-04)	2.92E-04	2.26E-04	1.88E-04
FIRST DATA ALT		300	300	300	300
LAST DATA ALT		840	900	900	900

FLIGHT NO. C-394
EQUIVALENT ATTENUATION LENGTH

(JOB 5506 DATE 09/23/77)
 DATE 111876 FLIGHT NO. C-394 GROUND LEVEL ALTITUDE (M)= 0

ALTITUDE (M)	FILTERS	EQUIVALENT ATTENUATION LENGTH (M)			
		2	4	3	5
0	2.45E 03	4.29E 03	9.57E 03	1.47E 04	
300	2.49E 03	4.36E 03	9.72E 03	1.49E 04	
600	2.88E 03	4.71E 03	1.02E 04	1.47E 04	
900	3.11E 03	4.41E 03	7.70E 03	9.96E 03	

FLIGHT NO. C-394
VERTICAL BEAM TRANSMITTANCE FROM GROUND TO ALTITUDE

ALTITUDE (M)	FILTERS	VERTICAL BEAM TRANSMITTANCE FROM GROUND TO ALTITUDE			
		2	4	3	5
0	1.00E 00	1.00E 00	1.00E 00	1.00E 00	
300	8.86E-01	9.33E-01	9.70E-01	9.80E-01	
600	8.12E-01	8.80E-01	9.43E-01	9.60E-01	
900	7.49E-01	8.15E-01	8.90E-01	9.14E-01	

FLIGHT C-395 – 19 NOVEMBER 1976 – DESCRIPTION OF FLIGHT AND WEATHER CHARACTERISTICS

Filter Ident	Data Interval			Solar Zenith Angle			Flight Altitude (meters)		Average Terrain Elevation (meters)
	Start (GMT)	End (GMT)	Elapsed (hrs) (min)	Initial (degrees)	Solar Transit (degrees)	Final (degrees)	(min)	(max)	
2,3	1150	1319	1 29	75 0	–	79 9	300	4440	0
4,5	1256	1422	1 26	78 2	–	85 8	300	4440	0

Flight C-395 was an afternoon flight commencing shortly after local apparent noon. Thin broken and high clouds gradually increased in amount and opacity through the afternoon.

The approximate southeast to northwest Rodby track was located south of Lolland Island, Denmark. Typical terrain features along the nearby coast to the north of the track were flat cultivated farmlands interspersed with occasional woods and small towns. Directly beneath the track and to the south were the relatively shallow waters of Femer Bay.

The in-flight observer reported thin broken altostratus at 5400 meters (18000 feet) and 3/8 thin cirrus with the altostratus deck increasing in extent and density occasionally breaking up for short periods. Visibility was noted as 6 to 10 miles with light haze. At times there was no discernible haze over the eastern portion of the track while brown/gray haze was observed in the western portion.

At Fehmarnbelt, south of the track, 2/8 thin cirrus was observed at 7500 meters (25000 feet) at 1200 GMT and 7/8 stratocumulus at 1500 meters (5000 feet) was reported at 1500 GMT. Visibility was reported as 10 kilometers at 1200 GMT and 20 kilometers at 1500 GMT.

Kegnaes, located west of the western end of the track, reported 3/8 altocumulus at 5400 meters (18000 feet) and 5/8 thin cirrus at 7500 meters (25000 feet). Visibility ranged from 15 to 20 kilometers.

The radiosonde station at Schleswig was approximately 106 kilometers west of the flight track center point on a line that ran crosswind to the prevailing airflow.

The surface chart for 1200 GMT had a 1044-millibar high centered in the Irish Sea which had strengthened in the past 24 hours and was dominating all of Europe. At 500 millibars there was a trough from Finland through Latvia and a high moving from the Atlantic towards Ireland. Moderate to strong northerly flow was over the region of the flight. The airmass was unstable maritime polar.

FLIGHT NO. C-395

ROBBY

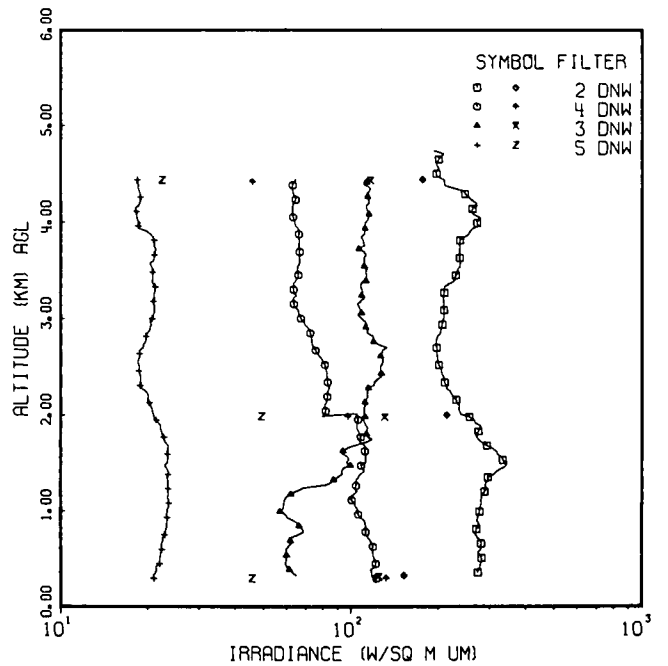
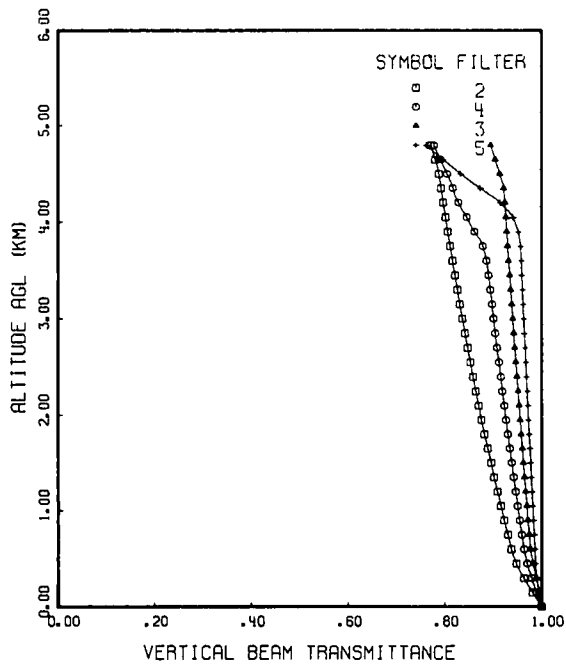
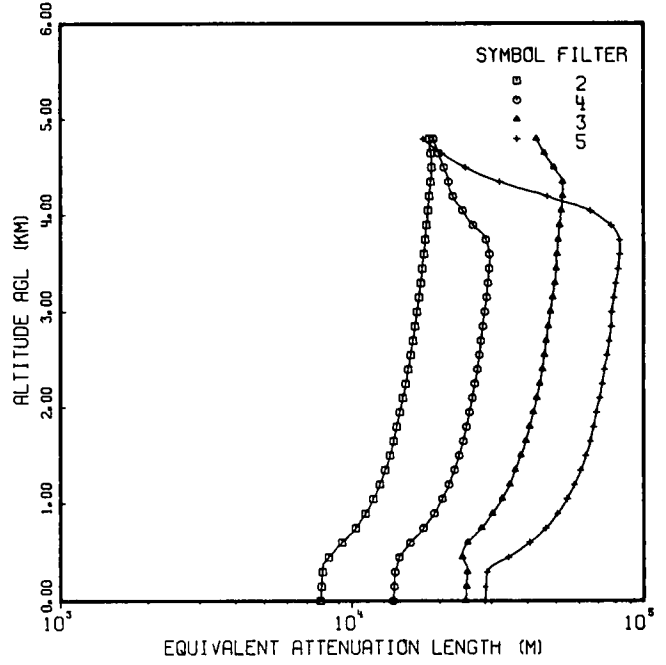
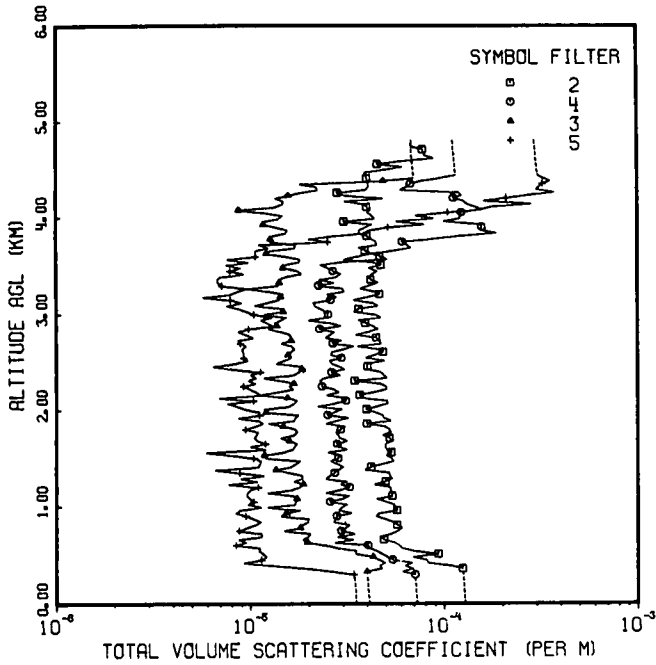

FLIGHT NO. C-395
TOTAL VOLUME SCATTERING COEFFICIENT

(JOB 4338 DATE 06/24/77)
 DATE 111976 FLIGHT NO. C-395 GROUND LEVEL ALTITUDE (M)= 0

ALTITUDE (M)	FILTERS	TOTAL VOLUME SCATTERING COEFFICIENT (PER M)			
		2	4	3	5
0		(1.28E-04)	(7.24E-05)	(4.09E-05)	(3.51E-05)
30		(1.28E-04)	(7.20E-05)	(4.07E-05)	(3.49E-05)
60		(1.27E-04)	(7.18E-05)	(4.06E-05)	(3.48E-05)
90		(1.27E-04)	(7.17E-05)	(4.05E-05)	(3.47E-05)
120		(1.27E-04)	(7.15E-05)	(4.04E-05)	(3.46E-05)
150		(1.26E-04)	(7.13E-05)	(4.03E-05)	(3.46E-05)
180		(1.26E-04)	(7.11E-05)	(4.02E-05)	(3.45E-05)
210		(1.26E-04)	(7.09E-05)	(4.01E-05)	(3.44E-05)
240		(1.26E-04)	(7.07E-05)	(4.00E-05)	(3.43E-05)
270		(1.25E-04)	(7.06E-05)	(3.99E-05)	(3.42E-05)
300		(1.25E-04)	7.04E-05	(3.98E-05)	3.41E-05
330		(1.25E-04)	6.07E-05	3.97E-05	2.61E-05
360		1.24E-04	6.89E-05	4.74E-05	1.99E-05
390		1.08E-04	6.23E-05	4.64E-05	1.30E-05
420		8.19E-05	6.81E-05	4.93E-05	9.17E-06
450		8.06E-05	5.40E-05	4.55E-05	1.14E-05
480		6.88E-05	5.05E-05	4.28E-05	1.20E-05
510		9.29E-05	4.74E-05	3.47E-05	1.15E-05
540		6.88E-05	4.43E-05	3.48E-05	1.10E-05
570		6.01E-05	4.08E-05	2.78E-05	1.12E-05
600		5.83E-05	4.02E-05	2.40E-05	8.42E-06
630		5.49E-05	2.72E-05	1.96E-05	9.52E-06
660		4.86E-05	3.38E-05	1.85E-05	8.70E-06
690		4.66E-05	2.81E-05	1.99E-05	1.14E-05
720		5.32E-05	3.44E-05	2.03E-05	1.14E-05
750		5.75E-05	2.93E-05	1.49E-05	8.73E-06
780		6.06E-05	3.10E-05	1.80E-05	9.55E-06
810		5.68E-05	3.24E-05	1.86E-05	1.05E-05
840		5.47E-05	2.68E-05	1.97E-05	1.13E-05
870		4.94E-05	2.73E-05	1.99E-05	1.04E-05
900		4.41E-05	2.78E-05	1.43E-05	9.47E-06
930		4.63E-05	3.31E-05	1.53E-05	8.39E-06
960		5.68E-05	2.85E-05	1.80E-05	8.90E-06
990		5.51E-05	2.95E-05	1.22E-05	1.13E-05
1020		5.50E-05	3.14E-05	1.69E-05	9.69E-06
1050		4.99E-05	2.57E-05	1.71E-05	1.04E-05
1080		4.47E-05	2.97E-05	1.73E-05	9.92E-06
1110		5.37E-05	3.22E-05	1.66E-05	9.59E-06
1140		5.33E-05	2.43E-05	1.23E-05	9.66E-06
1170		5.29E-05	2.90E-05	1.63E-05	9.91E-06
1200		5.24E-05	3.24E-05	1.80E-05	1.10E-05
1230		4.36E-05	2.91E-05	1.87E-05	7.69E-06
1260		4.97E-05	3.12E-05	1.68E-05	1.08E-05
1290		5.36E-05	2.43E-05	1.86E-05	8.90E-06
1320		5.22E-05	2.58E-05	1.84E-05	1.17E-05
1350		5.19E-05	2.71E-05	1.57E-05	8.78E-06
1380		3.89E-05	2.84E-05	1.35E-05	6.55E-06
1410		4.18E-05	3.01E-05	1.62E-05	1.10E-05
1440		4.83E-05	2.79E-05	1.72E-05	1.12E-05
1470		5.47E-05	2.58E-05	1.81E-05	1.14E-05
1500		5.33E-05	2.84E-05	1.20E-05	1.04E-05

FLIGHT NO. C-395
TOTAL VOLUME SCATTERING COEFFICIENT

(JOB 4338 DATE 06/24/77)
 DATE 111976 FLIGHT NO. C-395 GROUND LEVEL ALTITUDE (M)= 0

ALTITUDE (M)	TOTAL VOLUME SCATTERING COEFFICIENT (PER M)				
	FILTERS	2	4	3	5
1530		5.01E-05	2.94E-05	1.18E-05	8.14E-06
1560		5.33E-05	2.51E-05	1.49E-05	5.89E-06
1590		5.03E-05	3.15E-05	1.66E-05	1.20E-05
1620		4.95E-05	2.81E-05	1.69E-05	9.97E-06
1650		4.98E-05	2.80E-05	1.74E-05	1.19E-05
1680		5.39E-05	3.15E-05	1.58E-05	1.09E-05
1710		5.22E-05	2.89E-05	1.43E-05	1.05E-05
1740		4.80E-05	2.85E-05	1.68E-05	1.07E-05
1770		5.30E-05	2.75E-05	1.74E-05	1.10E-05
1800		5.18E-05	2.92E-05	1.71E-05	9.44E-06
1830		4.95E-05	3.07E-05	1.47E-05	1.05E-05
1860		3.98E-05	2.45E-05	1.24E-05	1.16E-05
1890		5.32E-05	2.81E-05	1.69E-05	1.10E-05
1920		4.85E-05	3.18E-05	1.70E-05	8.61E-06
1950		4.81E-05	2.50E-05	1.76E-05	1.11E-05
1980		4.36E-05	2.71E-05	1.21E-05	1.10E-05
2010		3.96E-05	2.95E-05	1.18E-05	9.28E-06
2040		4.54E-05	2.74E-05	1.59E-05	8.44E-06
2070		5.12E-05	2.72E-05	1.69E-05	7.60E-06
2100		5.07E-05	3.10E-05	1.73E-05	1.04E-05
2130		3.74E-05	3.12E-05	1.55E-05	6.91E-06
2160		3.66E-05	2.48E-05	1.12E-05	1.13E-05
2190		4.36E-05	2.87E-05	1.35E-05	1.07E-05
2220		5.06E-05	2.69E-05	1.67E-05	9.98E-06
2250		5.02E-05	2.34E-05	1.58E-05	9.21E-06
2280		4.62E-05	2.36E-05	1.67E-05	1.06E-05
2310		3.45E-05	2.28E-05	1.44E-05	9.75E-06
2340		5.07E-05	2.42E-05	1.18E-05	1.07E-05
2370		4.85E-05	2.91E-05	1.68E-05	1.00E-05
2400		4.69E-05	2.62E-05	1.79E-05	1.13E-05
2430		3.98E-05	3.06E-05	1.84E-05	8.20E-06
2460		4.02E-05	2.84E-05	1.84E-05	6.42E-06
2490		4.06E-05	2.62E-05	1.36E-05	8.34E-06
2520		4.95E-05	2.56E-05	1.49E-05	9.68E-06
2550		3.94E-05	2.94E-05	1.63E-05	9.24E-06
2580		4.39E-05	2.60E-05	1.56E-05	9.22E-06
2610		4.84E-05	2.63E-05	1.62E-05	9.19E-06
2640		4.58E-05	3.05E-05	1.69E-05	9.06E-06
2670		3.59E-05	3.40E-05	1.63E-05	9.56E-06
2700		4.75E-05	2.66E-05	1.44E-05	8.89E-06
2730		4.61E-05	2.94E-05	1.63E-05	8.61E-06
2760		4.47E-05	2.45E-05	1.61E-05	1.04E-05
2790		3.50E-05	2.58E-05	1.60E-05	9.50E-06
2820		4.10E-05	2.71E-05	1.43E-05	8.62E-06
2850		4.55E-05	2.27E-05	1.24E-05	9.84E-06
2880		4.24E-05	2.93E-05	1.37E-05	1.31E-05
2910		3.92E-05	2.56E-05	1.34E-05	1.22E-05
2940		3.61E-05	2.00E-05	1.44E-05	1.13E-05
2970		4.73E-05	2.50E-05	1.53E-05	1.29E-05
3000		4.38E-05	2.53E-05	1.18E-05	1.05E-05

FLIGHT NO. C-395
TOTAL VOLUME SCATTERING COEFFICIENT

(JOB 4338 DATE 06/24/77)
 DATE 111976 FLIGHT NO. C-395 GROUND LEVEL ALTITUDE (M)= 0

ALTITUDE (M)	FILTERS	TOTAL VOLUME SCATTERING COEFFICIENT (PER M)			
		2	4	3	5
3030		3.42E-05	2.44E-05	1.48E-05	9.56E-06
3060		3.63E-05	2.27E-05	1.49E-05	8.65E-06
3090		4.55E-05	2.15E-05	1.06E-05	7.57E-06
3120		4.24E-05	2.11E-05	1.23E-05	9.04E-06
3150		3.41E-05	2.60E-05	1.41E-05	7.92E-06
3180		4.03E-05	2.80E-05	1.44E-05	5.69E-06
3210		4.65E-05	2.49E-05	1.49E-05	7.92E-06
3240		4.34E-05	3.06E-05	1.25E-05	8.59E-06
3270		3.70E-05	2.99E-05	9.74E-06	9.65E-06
3300		4.13E-05	2.26E-05	1.39E-05	7.15E-06
3330		4.56E-05	2.72E-05	1.42E-05	6.80E-06
3360		4.20E-05	2.28E-05	1.40E-05	6.76E-06
3390		4.08E-05	2.79E-05	1.53E-05	7.01E-06
3420		4.30E-05	2.94E-05	1.85E-05	9.27E-06
3450		4.52E-05	2.68E-05	1.75E-05	7.91E-06
3480		4.08E-05	2.49E-05	1.48E-05	8.95E-06
3510		4.74E-05	2.31E-05	1.51E-05	7.55E-06
3540		4.21E-05	2.93E-05	1.79E-05	9.82E-06
3570		3.06E-05	5.09E-05	1.81E-05	7.62E-06
3600		3.63E-05	4.66E-05	1.51E-05	1.07E-05
3630		4.21E-05	4.24E-05	1.22E-05	1.07E-05
3660		3.93E-05	5.50E-05	1.28E-05	1.07E-05
3690		3.64E-05	6.77E-05	1.71E-05	1.24E-05
3720		4.52E-05	6.43E-05	1.72E-05	1.11E-05
3750		4.47E-05	6.09E-05	1.28E-05	2.53E-05
3780		4.23E-05	8.87E-05	1.28E-05	2.01E-05
3810		4.01E-05	1.21E-04	1.28E-05	2.61E-05
3840		3.64E-05	1.88E-04	1.53E-05	3.92E-05
3870		3.67E-05	1.54E-04	1.57E-05	4.12E-05
3900		3.96E-05	1.57E-04	1.37E-05	5.17E-05
3930		4.25E-05	1.51E-04	1.17E-05	7.94E-05
3960		3.05E-05	9.99E-05	1.17E-05	5.71E-05
3990		4.40E-05	1.21E-04	1.41E-05	8.89E-05
4020		4.26E-05	1.22E-04	1.48E-05	7.16E-05
4050		4.02E-05	1.24E-04	1.19E-05	1.05E-04
4080		4.15E-05	1.57E-04	8.76E-06	1.55E-04
4110		4.00E-05	1.44E-04	1.36E-05	1.78E-04
4140		3.88E-05	1.31E-04	1.48E-05	2.85E-04
4170		3.08E-05	1.27E-04	1.50E-05	1.61E-04
4200		4.86E-05	1.12E-04	1.35E-05	2.11E-04
4230		3.09E-05	1.24E-04	1.58E-05	2.73E-04
4260		2.82E-05	1.19E-04	1.81E-05	3.75E-04
4290		3.97E-05	5.95E-05	2.25E-05	3.01E-04
4320		4.10E-05	6.47E-05	2.21E-05	3.13E-04
4350		4.07E-05	6.73E-05	1.82E-05	3.24E-04
4380		4.05E-05	7.66E-05	4.87E-05	3.56E-04
4410		4.01E-05	9.61E-05	7.02E-05	3.22E-04
4440		3.96E-05	1.16E-04	(6.99E-05)	3.05E-04
4470		3.91E-05	(1.15E-04)	(6.97E-05)	(3.04E-04)
4500		4.91E-05	(1.15E-04)	(6.95E-05)	(3.03E-04)

FLIGHT NO. C-395
TOTAL VOLUME SCATTERING COEFFICIENT

(JOB 4338 DATE 06/24/77)
 DATE 111976 FLIGHT NO. C-395 GROUND LEVEL ALTITUDE (M)= 0

ALTITUDE (M)	TOTAL VOLUME SCATTERING COEFFICIENT (PER M)				
	FILTERS	2	4	3	5
4530	6.15E-05	(1.14E-04)	(6.93E-05)	(3.03E-04)	
4560	4.54E-05	(1.14E-04)	(6.91E-05)	(3.02E-04)	
4590	6.04E-05	(1.14E-04)	(6.89E-05)	(3.01E-04)	
4620	8.89E-05	(1.13E-04)	(6.86E-05)	(3.00E-04)	
4650	7.94E-05	(1.13E-04)	(6.84E-05)	(2.99E-04)	
4680	7.87E-05	(1.13E-04)	(6.82E-05)	(2.98E-04)	
4710	7.79E-05	(1.12E-04)	(6.80E-05)	(2.97E-04)	
4740	6.86E-05	(1.12E-04)	(6.78E-05)	(2.96E-04)	
4770	(6.84E-05)	(1.12E-04)	(6.76E-05)	(2.95E-04)	
4800	(6.82E-05)	(1.11E-04)	(6.74E-05)	(2.94E-04)	
FIRST DATA ALT	360	300	330	300	
LAST DATA ALT	4740	4440	4410	4440	

FLIGHT NO. C-395
EQUIVALENT ATTENUATION LENGTH

(JOB 4338 DATE 06/24/77)
 DATE 111976 FLIGHT NO. C-395 GROUND LEVEL ALTITUDE (M)= 0

ALTITUDE (M)	EQUIVALENT ATTENUATION LENGTH (M)			
	FILTERS 2	4	3	5
0	7.79E 03	1.38E 04	2.44E 04	2.85E 04
300	7.91E 03	1.40E 04	2.48E 04	2.89E 04
600	9.23E 03	1.58E 04	2.49E 04	4.06E 04
900	1.11E 04	1.91E 04	3.02E 04	5.06E 04
1200	1.24E 04	2.15E 04	3.48E 04	5.79E 04
1500	1.35E 04	2.33E 04	3.79E 04	6.33E 04
1800	1.42E 04	2.47E 04	4.07E 04	6.74E 04
2100	1.49E 04	2.59E 04	4.30E 04	7.07E 04
2400	1.56E 04	2.69E 04	4.50E 04	7.34E 04
2700	1.62E 04	2.77E 04	4.64E 04	7.64E 04
3000	1.67E 04	2.85E 04	4.79E 04	7.78E 04
3300	1.72E 04	2.92E 04	4.96E 04	8.04E 04
3600	1.76E 04	2.96E 04	5.05E 04	8.28E 04
3900	1.80E 04	2.60E 04	5.16E 04	7.75E 04
4200	1.84E 04	2.22E 04	5.28E 04	4.68E 04
4500	1.88E 04	2.06E 04	4.92E 04	2.45E 04
4800	1.84E 04	1.91E 04	4.29E 04	1.76E 04

FLIGHT NO. C-395
VERTICAL BEAM TRANSMITTANCE FROM GROUND TO ALTITUDE

ALTITUDE (M)	VERTICAL BEAM TRANSMITTANCE FROM GROUND TO ALTITUDE			
	FILTERS 2	4	3	5
0	1.00E 00	1.00E 00	1.00E 00	1.00E 00
300	9.63E-01	9.79E-01	9.88E-01	9.90E-01
600	9.37E-01	9.63E-01	9.76E-01	9.85E-01
900	9.22E-01	9.54E-01	9.71E-01	9.82E-01
1200	9.08E-01	9.46E-01	9.66E-01	9.79E-01
1500	8.95E-01	9.38E-01	9.61E-01	9.77E-01
1800	8.81E-01	9.30E-01	9.57E-01	9.74E-01
2100	8.69E-01	9.22E-01	9.52E-01	9.71E-01
2400	8.57E-01	9.15E-01	9.48E-01	9.68E-01
2700	8.46E-01	9.07E-01	9.43E-01	9.65E-01
3000	8.36E-01	9.00E-01	9.39E-01	9.62E-01
3300	8.26E-01	8.93E-01	9.36E-01	9.60E-01
3600	8.15E-01	8.85E-01	9.31E-01	9.57E-01
3900	8.06E-01	8.61E-01	9.27E-01	9.51E-01
4200	7.96E-01	8.27E-01	9.24E-01	9.14E-01
4500	7.87E-01	8.04E-01	9.13E-01	8.32E-01
4800	7.71E-01	7.77E-01	8.94E-01	7.61E-01

FLIGHT C-397 – 23 NOVEMBER 1976 – DESCRIPTION OF FLIGHT AND WEATHER CHARACTERISTICS

Filter Ident	Data Interval			Solar Zenith Angle			Flight Altitude (meters)		Average Terrain Elevation (meters)
	Start (GMT)	End (GMT)	Elapsed (hrs) (min)	Initial (degrees)	Solar Transit (degrees)	Final (degrees)	(min)	(max)	
2,3	1202	1257	0 55	74 1	–	76 7	300	4320	18
4	1238	1259	0 21	75 5	–	76 8	330	4320	18
5	1259	1317	0 18	76 8	–	78 0	300	4320	18

Flight C-397 was an afternoon flight. Low and high cloud layers were present with snow and rain showers in the area.

The approximate northeast to southwest Meppen track was located between Oldenburg and Lathen in northwestern Germany. Typical terrain features were heavily cultivated low lying flat farmlands interspersed with occasional dark woods and small towns.

The in-flight observer noted patches of thin water clouds from 1500 to 1800 feet, light haze and snow showers throughout the area. By 1300 GMT clouds were moving into the track with bases 2000 feet and tops 10000 feet. There were some clear areas.

Lingen, south of the track, reported 3/8 cumulonimbus at 450 meters (1500 feet) at 1100 GMT, visibility was 35 kilometers. The 1200 GMT report was missing. At 1300 GMT and thereafter 6/8 cirrostratus at 6000 meters (20000 feet) were present in addition to the low clouds. Visibility of 30 kilometers at 1300 GMT reduced to 20 kilometers at 1400 and 1500 GMT. The observations noted distant rain showers.

Oldenburg, west of the track, included ceiling and visibility data in the hourly reports but no cloud types or amounts. Scattered variable broken low clouds at 450 meters (1500 feet) were reported with occasional rain and snow showers. Visibility ranged from 7.0 to 11.2 km.

The radiosonde station at Rheine/Waldhugel was approximately 81 kilometers south and downstream from the flight track center point.

The surface chart for 1200 GMT showed that a secondary low had formed near Leningrad with a pressure of 992 millibars. From this low a cold front extended south and southwest to another low centered near Athens. This low was partially blocking the 1038-millibar high located at 49N 16W from moving into Ireland and was shunting it towards France. At 500 millibars there was a trough over eastern Latvia with ridging west of Ireland that produced moderate to strong northwesterly flow. The airmass was unstable maritime polar.

FLIGHT NO. C-397

MEPPEN

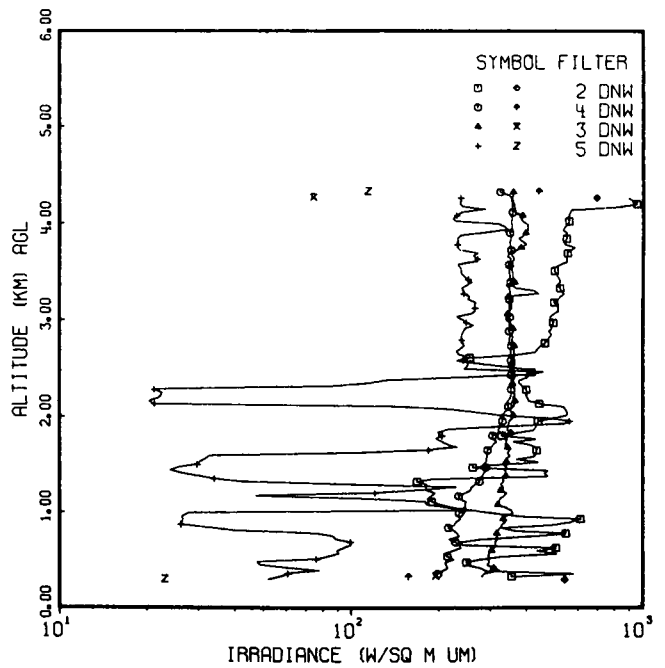
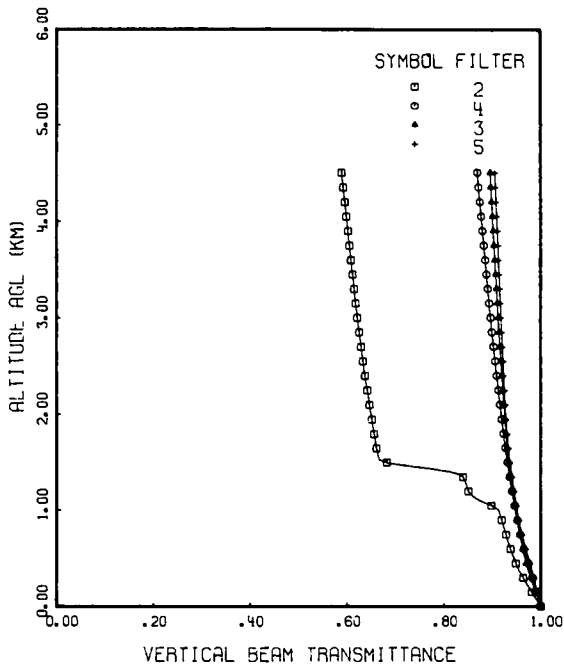
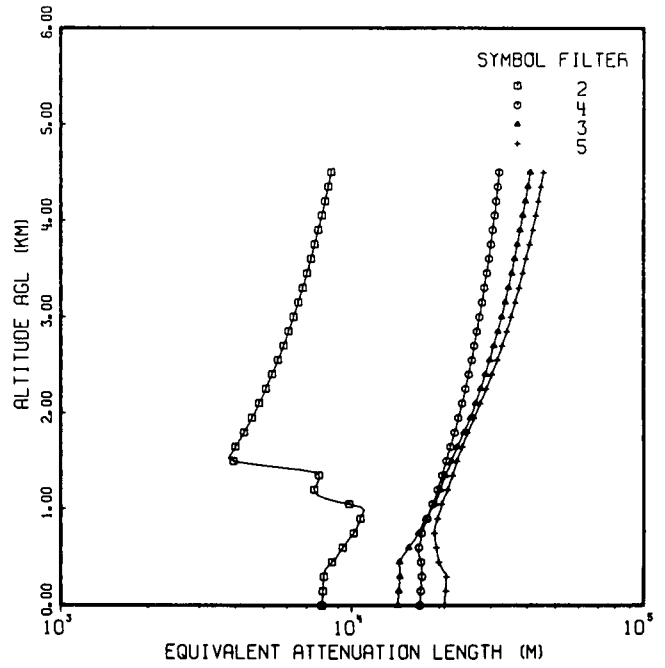
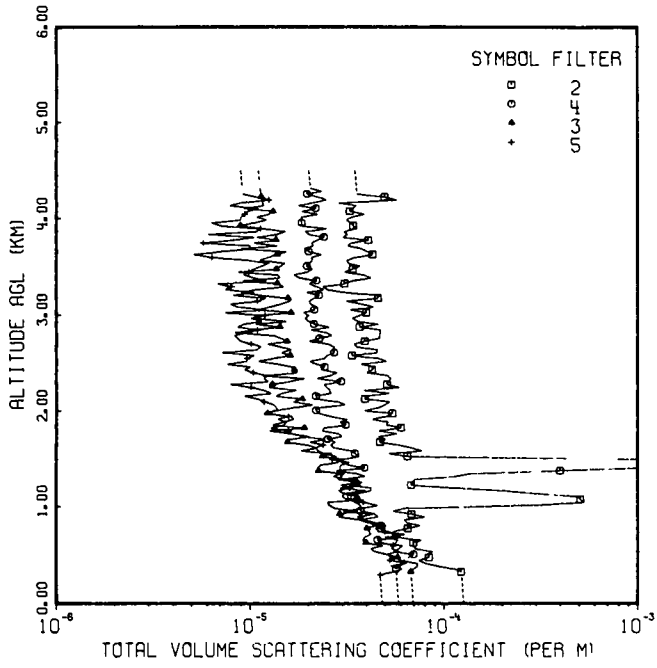

FLIGHT NO. C-397
TOTAL VOLUME SCATTERING COEFFICIENT

(JOB 4336 DATE 06/24/77)
 DATE 112376 FLIGHT NO. C-397 GROUND LEVEL ALTITUDE (M)= 18

ALTITUDE (M)	TOTAL VOLUME SCATTERING COEFFICIENT (PER M)			
	FILTERS	2	4	3
0	(1.27E-04)	(5.84E-05)	(6.96E-05)	(4.81E-05)
30	(1.26E-04)	(5.81E-05)	(6.92E-05)	(4.79E-05)
60	(1.26E-04)	(5.80E-05)	(6.91E-05)	(4.77E-05)
90	(1.25E-04)	(5.79E-05)	(6.89E-05)	(4.76E-05)
120	(1.25E-04)	(5.77E-05)	(6.87E-05)	(4.75E-05)
150	(1.25E-04)	(5.76E-05)	(6.85E-05)	(4.74E-05)
180	(1.24E-04)	(5.74E-05)	(6.84E-05)	(4.73E-05)
210	(1.24E-04)	(5.73E-05)	(6.82E-05)	(4.71E-05)
240	(1.24E-04)	(5.71E-05)	(6.80E-05)	(4.70E-05)
270	(1.23E-04)	(5.70E-05)	(6.78E-05)	(4.69E-05)
300	(1.23E-04)	(5.68E-05)	(6.76E-05)	4.68E-05
330	1.23E-04	(5.67E-05)	6.75E-05	5.49E-05
360	1.13E-04	5.65E-05	6.97E-05	6.09E-05
390	4.30E-05	5.92E-05	7.31E-05	5.29E-05
420	7.94E-05	6.20E-05	7.26E-05	6.40E-05
450	7.36E-05	6.19E-05	5.88E-05	5.26E-05
480	8.34E-05	6.59E-05	5.75E-05	5.54E-05
510	8.22E-05	6.96E-05	5.05E-05	5.02E-05
540	8.72E-05	5.50E-05	4.35E-05	5.84E-05
570	7.08E-05	5.88E-05	4.17E-05	5.36E-05
600	6.95E-05	6.12E-05	4.82E-05	5.46E-05
630	6.95E-05	4.68E-05	3.95E-05	5.62E-05
660	7.65E-05	4.54E-05	3.80E-05	5.78E-05
690	5.63E-05	5.92E-05	3.89E-05	4.96E-05
720	5.45E-05	5.89E-05	4.20E-05	6.29E-05
750	5.49E-05	4.56E-05	4.10E-05	4.95E-05
780	6.50E-05	4.43E-05	3.99E-05	4.61E-05
810	7.54E-05	4.71E-05	4.45E-05	5.05E-05
840	6.42E-05	4.04E-05	4.09E-05	4.42E-05
870	6.22E-05	3.66E-05	3.74E-05	3.80E-05
900	7.94E-05	4.57E-05	2.87E-05	3.70E-05
930	6.78E-05	4.40E-05	2.89E-05	4.36E-05
960	5.44E-05	3.71E-05	3.53E-05	3.03E-05
990	6.27E-05	3.76E-05	2.72E-05	3.78E-05
1020	2.93E-04	3.67E-05	2.54E-05	4.54E-05
1050	5.23E-04	3.48E-05	2.50E-05	3.83E-05
1080	5.05E-04	3.27E-05	3.61E-05	3.12E-05
1110	4.77E-04	3.32E-05	3.66E-05	2.97E-05
1140	3.02E-04	3.57E-05	3.02E-05	3.04E-05
1170	2.08E-04	4.19E-05	3.93E-05	2.84E-05
1200	1.14E-04	4.20E-05	2.92E-05	3.27E-05
1230	6.77E-05	3.28E-05	3.57E-05	2.93E-05
1260	6.90E-05	3.47E-05	3.75E-05	3.79E-05
1290	7.04E-05	2.91E-05	2.83E-05	3.00E-05
1320	1.14E-04	3.91E-05	2.97E-05	2.67E-05
1350	1.37E-04	3.52E-05	3.00E-05	2.94E-05
1380	3.97E-04	2.78E-05	2.24E-05	2.90E-05
1410	1.57E-03	3.88E-05	2.23E-05	2.90E-05
1440	1.89E-03	3.22E-05	2.30E-05	2.93E-05
1470	2.24E-03	2.94E-05	2.84E-05	3.25E-05
1500	1.52E-03	2.96E-05	2.95E-05	2.65E-05

FLIGHT NO. C-397
TOTAL VOLUME SCATTERING COEFFICIENT

(JOB 4336 DATE 06/24/77)
 DATE 112376 FLIGHT NO. C-397 GROUND LEVEL ALTITUDE (M)= 18

ALTITUDE (M)	TOTAL VOLUME SCATTERING COEFFICIENT (PFR M)				
	FILTERS	2	4	3	5
1530		6.48E-05	3.63E-05	2.35E-05	2.79E-05
1560		5.17E-05	3.46E-05	2.64E-05	2.35E-05
1590		7.70E-05	3.30E-05	1.82E-05	2.24E-05
1620		6.76E-05	2.69E-05	2.20E-05	2.17E-05
1650		5.83E-05	2.60E-05	1.96E-05	2.38E-05
1680		4.66E-05	2.75E-05	1.55E-05	2.02E-05
1710		5.00E-05	2.51E-05	1.60E-05	2.43E-05
1740		4.57E-05	2.97E-05	2.02E-05	1.90E-05
1770		5.72E-05	2.85E-05	1.62E-05	1.62E-05
1800		4.60E-05	2.35E-05	1.26E-05	1.58E-05
1830		6.00E-05	2.40E-05	1.91E-05	1.28E-05
1860		5.01E-05	3.11E-05	1.30E-05	1.49E-05
1890		5.16E-05	2.91E-05	1.49E-05	1.54E-05
1920		4.24E-05	3.16E-05	1.68E-05	1.38E-05
1950		5.08E-05	2.59E-05	1.63E-05	1.58E-05
1980		5.42E-05	2.25E-05	1.23E-05	1.17E-05
2010		3.88E-05	2.19E-05	1.34E-05	1.40E-05
2040		4.64E-05	2.28E-05	1.68E-05	1.36E-05
2070		4.95E-05	3.08E-05	2.11E-05	1.32E-05
2100		5.26E-05	2.85E-05	1.67E-05	1.18E-05
2130		3.92E-05	2.22E-05	1.86E-05	1.10E-05
2160		4.05E-05	2.18E-05	1.36E-05	9.31E-06
2190		5.20E-05	2.61E-05	1.47E-05	1.29E-05
2220		3.86E-05	2.57E-05	1.73E-05	1.17E-05
2250		5.89E-05	2.49E-05	1.26E-05	1.01E-05
2280		5.09E-05	2.40E-05	1.30E-05	7.87E-06
2310		5.20E-05	2.95E-05	1.60E-05	1.24E-05
2340		5.31E-05	2.22E-05	1.90E-05	1.18E-05
2370		5.09E-05	2.60E-05	1.16E-05	1.22E-05
2400		4.00E-05	2.81E-05	1.74E-05	1.04E-05
2430		4.26E-05	2.32E-05	1.69E-05	9.32E-06
2460		4.41E-05	2.42E-05	1.65E-05	1.00E-05
2490		3.73E-05	2.19E-05	1.38E-05	7.59E-06
2520		5.06E-05	2.02E-05	1.10E-05	9.63E-06
2550		4.54E-05	2.42E-05	1.33E-05	9.64E-06
2580		3.35E-05	2.50E-05	1.61E-05	1.05E-05
2610		4.52E-05	2.70E-05	1.45E-05	7.17E-06
2640		4.54E-05	2.66E-05	1.63E-05	1.09E-05
2670		3.53E-05	2.72E-05	1.43E-05	1.14E-05
2700		3.44E-05	2.52E-05	1.23E-05	1.02E-05
2730		3.91E-05	2.02E-05	1.55E-05	8.91E-06
2760		4.65E-05	2.28E-05	1.44E-05	8.59E-06
2790		4.67E-05	2.65E-05	1.32E-05	8.28E-06
2820		4.68E-05	2.47E-05	8.32E-06	9.61E-06
2850		4.70E-05	2.07E-05	1.05E-05	1.09E-05
2880		3.68E-05	2.56E-05	1.42E-05	8.60E-06
2910		4.59E-05	2.13E-05	1.67E-05	9.34E-06
2940		3.57E-05	1.98E-05	1.55E-05	1.14E-05
2970		3.35E-05	1.92E-05	1.07E-05	1.01E-05
3000		3.66E-05	2.01E-05	1.06E-05	1.19E-05

FLIGHT NO. C-397

TOTAL VOLUME SCATTERING COEFFICIENT

(JOB 4336 DATE 06/24/77)
 DATE 112376 FLIGHT NO. C-397 GROUND LEVEL ALTITUDE (M)= 18

ALTITUDE (M)	TOTAL VOLUME SCATTERING COEFFICIENT (PER M)				
	FILTERS	2	4	3	5
3030		3.97E-05	1.88E-05	1.63E-05	7.43E-06
3060		3.28E-05	2.14E-05	1.10E-05	1.21E-05
3090		4.34E-05	2.19E-05	1.27E-05	8.50E-06
3120		3.74E-05	2.05E-05	1.45E-05	7.88E-06
3150		3.13E-05	2.02E-05	1.61E-05	1.09E-05
3180		4.57E-05	2.14E-05	1.57E-05	1.21E-05
3210		4.67E-05	2.27E-05	1.13E-05	8.18E-06
3240		3.11E-05	1.97E-05	9.05E-06	1.05E-05
3270		2.48E-05	2.39E-05	1.08E-05	7.42E-06
3300		2.37E-05	2.20E-05	1.49E-05	7.99E-06
3330		3.06E-05	2.01E-05	1.38E-05	6.78E-06
3360		3.43E-05	2.20E-05	9.21E-06	1.21E-05
3390		4.21E-05	1.79E-05	1.43E-05	1.04E-05
3420		3.83E-05	1.68E-05	1.38E-05	9.25E-06
3450		3.08E-05	1.98E-05	8.69E-06	9.87E-06
3480		3.39E-05	2.09E-05	1.36E-05	1.05E-05
3510		3.70E-05	1.96E-05	1.44E-05	1.15E-05
3540		3.21E-05	2.02E-05	1.51E-05	1.25E-05
3570		3.15E-05	2.09E-05	1.12E-05	9.70E-06
3600		3.49E-05	2.07E-05	1.25E-05	6.36E-06
3630		4.27E-05	2.34E-05	1.38E-05	5.11E-06
3660		4.02E-05	2.01E-05	1.53E-05	7.06E-06
3690		3.76E-05	1.90E-05	8.98E-06	1.01E-05
3720		3.20E-05	2.12E-05	1.38E-05	9.98E-06
3750		3.34E-05	2.07E-05	1.05E-05	5.73E-06
3780		4.08E-05	2.24E-05	1.36E-05	8.20E-06
3810		3.02E-05	2.41E-05	1.09E-05	1.05E-05
3840		3.18E-05	2.00E-05	1.38E-05	6.06E-06
3870		3.03E-05	1.93E-05	1.52E-05	1.08E-05
3900		3.53E-05	2.47E-05	1.16E-05	1.13E-05
3930		3.40E-05	1.85E-05	8.91E-06	7.03E-06
3960		3.26E-05	1.85E-05	1.06E-05	6.31E-06
3990		3.12E-05	1.85E-05	1.22E-05	8.95E-06
4020		3.37E-05	1.85E-05	1.08E-05	9.02E-06
4050		3.89E-05	2.23E-05	1.26E-05	9.39E-06
4080		3.27E-05	1.85E-05	1.41E-05	9.77E-06
4110		3.40E-05	2.18E-05	9.29E-06	1.10E-05
4140		3.53E-05	1.78E-05	1.18E-05	7.84E-06
4170		2.86E-05	2.13E-05	1.16E-05	9.04E-06
4200		5.73E-05	2.48E-05	1.16E-05	1.26E-05
4230		4.94E-05	2.22E-05	1.15E-05	1.09E-05
4260		3.56E-05	1.97E-05	1.14E-05	9.15E-06
4290	(3.55E-05)		2.34E-05	1.13E-05	(9.12E-06)
4320	(3.54E-05)		2.05E-05	1.12E-05	(9.09E-06)
4350	(3.53E-05)	(2.04E-05)		(1.12E-05)	(9.06E-06)
4380	(3.52E-05)	(2.03E-05)		(1.12E-05)	(9.04E-06)
4410	(3.51E-05)	(2.03E-05)		(1.11E-05)	(9.01E-06)
4440	(3.49E-05)	(2.02E-05)		(1.11E-05)	(8.98E-06)
4470	(3.48E-05)	(2.01E-05)		(1.11E-05)	(8.95E-06)
4500	(3.47E-05)	(2.01E-05)		(1.10E-05)	(8.92E-06)
FIRST DATA ALT	330	360	330	300	
LAST DATA ALT	4260	4320	4320	4260	

FLIGHT NO. C-397
EQUIVALENT ATTENUATION LENGTH

(JOB 4336 DATE 06/24/77)
 DATE 112376 FLIGHT NO. C-397 GROUND LEVEL ALTITUDE (M)= 18

ALTITUDE (M)	FILTERS	EQUIVALENT ATTENUATION LENGTH (M)			
		2	4	3	5
0	7.90E 03	1.71E 04	1.44E 04	2.08E 04	
300	8.01E 03	1.74E 04	1.46E 04	2.11E 04	
600	9.30E 03	1.69E 04	1.56E 04	1.95E 04	
900	1.07E 04	1.81E 04	1.79E 04	1.96E 04	
1200	7.42E 03	1.96E 04	2.01E 04	2.13E 04	
1500	3.92E 03	2.11E 04	2.19E 04	2.29E 04	
1800	4.27E 03	2.25E 04	2.42E 04	2.50E 04	
2100	4.81E 03	2.39E 04	2.66E 04	2.76E 04	
2400	5.32E 03	2.51E 04	2.87E 04	3.02E 04	
2700	5.82E 03	2.63E 04	3.06E 04	3.28E 04	
3000	6.30E 03	2.74E 04	3.27E 04	3.52E 04	
3300	6.78E 03	2.85E 04	3.45E 04	3.74E 04	
3600	7.24E 03	2.95E 04	3.62E 04	3.95E 04	
3900	7.68E 03	3.04E 04	3.77E 04	4.17E 04	
4200	8.10E 03	3.13E 04	3.93E 04	4.36E 04	
4500	8.50E 03	3.20E 04	4.09E 04	4.54E 04	

FLIGHT NO. C-397
VERTICAL BEAM TRANSMITTANCE FROM GROUND TO ALTITUDE

ALTITUDE (M)	FILTERS	VERTICAL BEAM TRANSMITTANCE FROM GROUND TO ALTITUDE			
		2	4	3	5
0	1.00E 00	1.00E 00	1.00E 00	1.00E 00	
300	9.63E-01	9.83E-01	9.80E-01	9.86E-01	
600	9.38E-01	9.65E-01	9.62E-01	9.70E-01	
900	9.19E-01	9.51E-01	9.51E-01	9.55E-01	
1200	8.51E-01	9.41E-01	9.42E-01	9.45E-01	
1500	6.82E-01	9.31E-01	9.34E-01	9.37E-01	
1800	6.56E-01	9.23E-01	9.28E-01	9.31E-01	
2100	6.46E-01	9.16E-01	9.24E-01	9.27E-01	
2400	6.37E-01	9.09E-01	9.20E-01	9.24E-01	
2700	6.29E-01	9.02E-01	9.16E-01	9.21E-01	
3000	6.21E-01	8.96E-01	9.12E-01	9.18E-01	
3300	6.14E-01	8.91E-01	9.09E-01	9.16E-01	
3600	6.08E-01	8.85E-01	9.05E-01	9.13E-01	
3900	6.02E-01	8.80E-01	9.02E-01	9.11E-01	
4200	5.96E-01	8.74E-01	8.99E-01	9.08E-01	
4500	5.89E-01	8.69E-01	8.96E-01	9.06E-01	

FLIGHT C-398 – 2 DECEMBER 1976 – DESCRIPTION OF FLIGHT AND WEATHER CHARACTERISTICS

Filter Ident	Data Interval			Solar Zenith Angle			Flight Altitude (meters)		Average Terrain Elevation (meters)
	Start (GMT)	End (GMT)	Elapsed (hrs) (min)	Initial (degrees)	Solar Transit (degrees)	Final (degrees)	(min)	(max)	
2	1143	1306	1 23	70.1	70.0	71.8	420	4440	46
4	1315	1411	0 56	72.2	—	76.3	450	4410	46

Flight C-398 was a midday to afternoon flight. Multiple cloud layers were present with some clear areas in scattered to broken layers.

The approximate east to west Bruz track was centered south of Rennes in northwestern France. Typical terrain features were green fields interspersed with some brown areas and dark green trees.

The in-flight observer reported 1/8 to 2/8 cumulus and stratocumulus at 1200 meters (4000 feet), 3/8 to 4/8 altostratus at 4500 meters (15000 feet), and light to very light haze. At times the flight stayed low to stay below the clouds in the haze.

At Rennes/St. Jacques, north of the center of the track, 1/8 to 3/8 cumulus and stratocumulus were observed at 900 meters (3000 feet), 1/8 altocumulus at 3000 meters (10000 feet) gradually increased to 5/8 coverage. Visibility of 11.2 kilometers decreased to 8.0 kilometers in rain at 1500 GMT.

St. Nazaire-Montoir, south of the track, reported 1/8 cumulonimbus at 600 meters (2000 feet) at 1200 GMT increasing to overcast at 780 meters (2600 feet) by 1500 GMT. Altocumulus at 3000 meters (10000 feet) increased in coverage from 2/8 at 1200 GMT to 7/8 at 1400 GMT. Visibility of 30 kilometers decreased to 6.0 to 8.0 with light rain showers after 1400 GMT.

Nantes-Chateau Bougon, south of the track center, reported scattered 1/8 cumulonimbus at 900 meters (1500 feet), 2/8 altocumulus at 4500 meters (15000 feet) and 2/8 to 5/8 cirrus at 7500 meters (25000 feet). Visibility varied from 11.2 to 25 kilometers.

Anbers/Avrille, southeast of the track, had 5/8 cumulus and stratocumulus at 460 to 600 meters (1600 to 2000 feet) and 5/8 altocumulus at 3000 meters (10000 feet). Visibility was 11.2 to 15 kilometers.

The radiosonde station at Brest was approximately 200 kilometers westnorthwest and generally upstream from the flight track center point.

The surface chart for 1200 GMT had an extensive frontal system over Europe with a 970-millibar low centered near Cologne. The cold front portion of this system extended from western Austria southwest to northwestern Italy and west through the northernmost parts of Spain. This deep low system in conjunction with a 1035-millibar high located at 34N 32W produced a strong surface pressure gradient with resulting strong winds. At 500 millibars there was a low off Bergen, Norway with a trough extending southward to Sardinia. The flow over the region of the flight was strong northwesterly. The airmass was unstable maritime polar.

FLIGHT NO. C-398

BRUZ

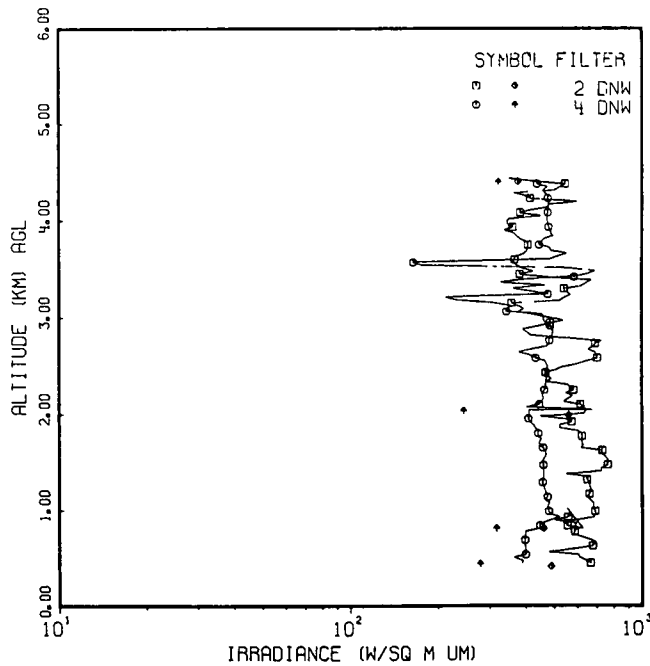
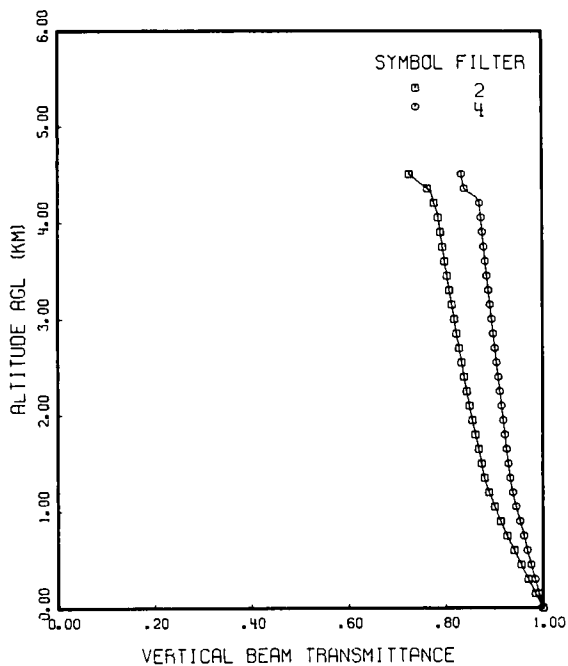
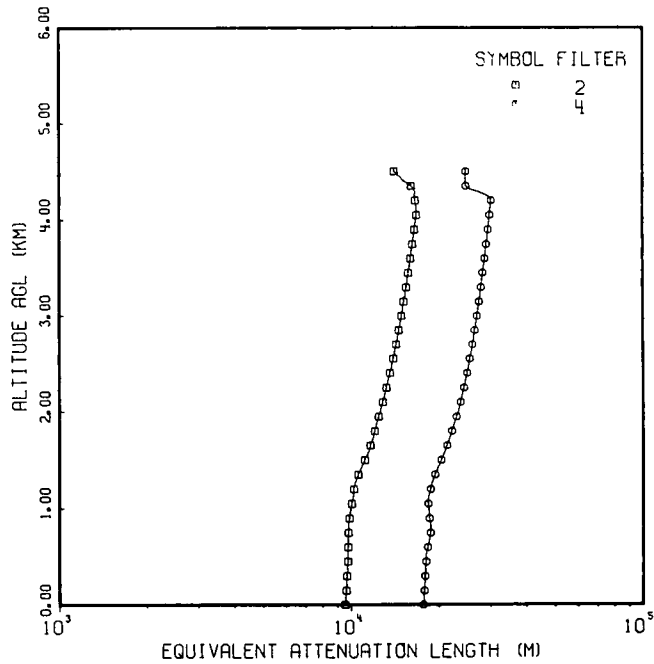
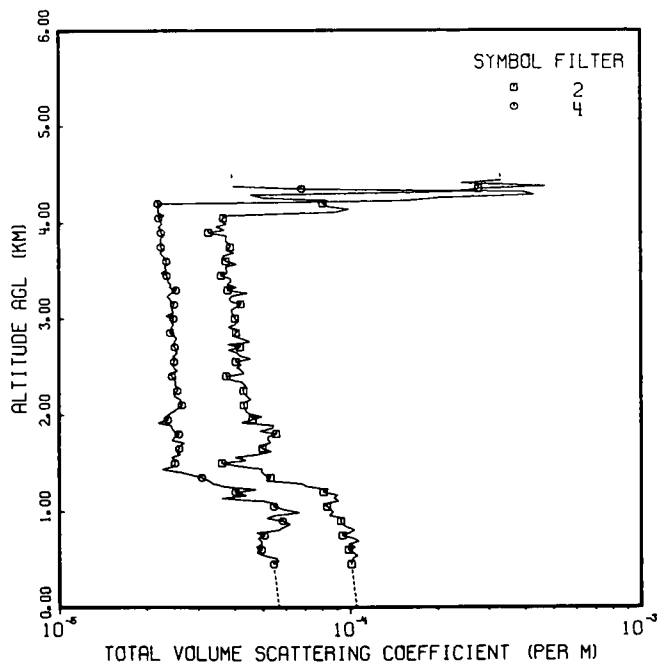

FLIGHT NO. C-398
TOTAL VOLUME SCATTERING COEFFICIENT

(JOB 4335 DATE 06/24/77)
 DATE 120276 FLIGHT NO. C-398 GROUND LEVEL ALTITUDE (M)= 46

ALTITUDE (M)	TOTAL VOLUME SCATTERING COEFFICIENT (PER M)	
	FILTERS 2	4
0	(1.05E-04)	(5.67E-05)
30	(1.05E-04)	(5.64E-05)
60	(1.04E-04)	(5.63E-05)
90	(1.04E-04)	(5.62E-05)
120	(1.04E-04)	(5.60E-05)
150	(1.03E-04)	(5.59E-05)
180	(1.03E-04)	(5.57E-05)
210	(1.03E-04)	(5.56E-05)
240	(1.03E-04)	(5.55E-05)
270	(1.02E-04)	(5.53E-05)
300	(1.02E-04)	(5.52E-05)
330	(1.02E-04)	(5.50E-05)
360	(1.02E-04)	(5.49E-05)
390	(1.01E-04)	(5.47E-05)
420	(1.01E-04)	(5.46E-05)
450	1.01E-04	5.44E-05
480	1.01E-04	5.65E-05
510	1.02E-04	5.58E-05
540	1.05E-04	5.04E-05
570	1.02E-04	4.75E-05
600	9.84E-05	4.95E-05
630	1.04E-04	4.74E-05
660	9.84E-05	4.95E-05
690	1.07E-04	4.94E-05
720	1.02E-04	4.81E-05
750	9.39E-05	5.06E-05
780	9.96E-05	4.75E-05
810	1.03E-04	5.69E-05
840	9.68E-05	5.92E-05
870	9.33E-05	6.20E-05
900	9.27E-05	5.84E-05
930	7.36E-05	5.15E-05
960	8.44E-05	5.53E-05
990	8.71E-05	6.69E-05
1020	8.58E-05	5.88E-05
1050	8.31E-05	5.45E-05
1080	8.04E-05	5.58E-05
1110	9.12E-05	5.01E-05
1140	8.78E-05	3.61E-05
1170	9.06E-05	4.40E-05
1200	8.08E-05	4.02E-05
1230	8.36E-05	4.73E-05
1260	7.04E-05	3.68E-05
1290	6.76E-05	3.35E-05
1320	5.13E-05	3.25E-05
1350	5.31E-05	3.08E-05
1380	5.08E-05	2.84E-05
1410	4.94E-05	2.60E-05
1440	4.48E-05	2.25E-05
1470	4.17E-05	2.47E-05
1500	3.62E-05	2.49E-05

FLIGHT NO. C-398
TOTAL VOLUME SCATTERING COEFFICIENT

(JOB 4335 DATE 06/24/77)
 DATE 120276 FLIGHT NO. C-398 GROUND LEVEL ALTITUDE (M)= 46

ALTITUDE (M)	TOTAL VOLUME SCATTERING COEFFICIENT (PER M)	
	FILTERS 2	4
1530	4.39E-05	2.51E-05
1560	4.02E-05	2.43E-05
1590	4.80E-05	2.60E-05
1620	5.36E-05	2.51E-05
1650	4.99E-05	2.58E-05
1680	4.85E-05	2.58E-05
1710	5.31E-05	2.69E-05
1740	5.22E-05	2.43E-05
1770	5.19E-05	2.49E-05
1800	5.56E-05	2.57E-05
1830	4.89E-05	2.47E-05
1860	5.41E-05	2.44E-05
1890	5.46E-05	2.42E-05
1920	4.23E-05	2.18E-05
1950	4.62E-05	2.36E-05
1980	4.97E-05	2.30E-05
2010	4.48E-05	2.39E-05
2040	4.36E-05	2.48E-05
2070	4.34E-05	2.57E-05
2100	4.31E-05	2.64E-05
2130	4.33E-05	2.58E-05
2160	4.56E-05	2.61E-05
2190	4.42E-05	2.50E-05
2220	4.31E-05	2.47E-05
2250	4.30E-05	2.54E-05
2280	4.33E-05	2.56E-05
2310	4.36E-05	2.50E-05
2340	4.24E-05	2.50E-05
2370	3.80E-05	2.51E-05
2400	3.75E-05	2.44E-05
2430	4.32E-05	2.40E-05
2460	4.23E-05	2.55E-05
2490	4.07E-05	2.47E-05
2520	4.23E-05	2.46E-05
2550	4.04E-05	2.48E-05
2580	4.55E-05	2.50E-05
2610	4.16E-05	2.46E-05
2640	4.10E-05	2.54E-05
2670	3.81E-05	2.52E-05
2700	4.18E-05	2.49E-05
2730	3.80E-05	2.45E-05
2760	4.52E-05	2.49E-05
2790	4.24E-05	2.53E-05
2820	3.96E-05	2.49E-05
2850	4.05E-05	2.40E-05
2880	4.14E-05	2.48E-05
2910	3.81E-05	2.42E-05
2940	4.02E-05	2.48E-05
2970	4.12E-05	2.43E-05
3000	4.02E-05	2.47E-05

FLIGHT NO. C-398
TOTAL VOLUME SCATTERING COEFFICIENT

(JOB 4335 DATE 06/24/77)
 DATE 120276 FLIGHT NO. C-398 GROUND LEVEL ALTITUDE (M)= 46

ALTITUDE (M)	TOTAL VOLUME SCATTERING COEFFICIENT (PER M)	
	FILTERS 2	4
3030	3.97E-05	2.33E-05
3060	3.93E-05	2.46E-05
3090	3.91E-05	2.44E-05
3120	4.05E-05	2.42E-05
3150	4.21E-05	2.48E-05
3180	3.90E-05	2.42E-05
3210	3.85E-05	2.40E-05
3240	3.93E-05	2.35E-05
3270	4.43E-05	2.44E-05
3300	3.80E-05	2.52E-05
3330	4.06E-05	2.40E-05
3360	3.77E-05	2.42E-05
3390	3.90E-05	2.36E-05
3420	3.87E-05	2.38E-05
3450	3.60E-05	2.34E-05
3480	3.79E-05	2.24E-05
3510	3.76E-05	2.34E-05
3540	3.73E-05	2.31E-05
3570	4.07E-05	2.34E-05
3600	3.75E-05	2.34E-05
3630	3.61E-05	2.31E-05
3660	3.68E-05	2.27E-05
3690	3.99E-05	2.22E-05
3720	3.74E-05	2.29E-05
3750	3.87E-05	2.24E-05
3780	3.84E-05	2.24E-05
3810	3.74E-05	2.24E-05
3840	3.75E-05	2.24E-05
3870	3.76E-05	2.30E-05
3900	3.26E-05	2.24E-05
3930	3.70E-05	2.24E-05
3960	3.46E-05	2.20E-05
3990	3.77E-05	2.26E-05
4020	3.60E-05	2.24E-05
4050	3.67E-05	2.20E-05
4080	3.85E-05	2.30E-05
4110	8.96E-05	2.19E-05
4140	9.93E-05	2.20E-05
4170	8.37E-05	2.20E-05
4200	8.07E-05	2.19E-05
4230	8.38E-05	1.56E-04
4260	5.01E-05	2.02E-04
4290	4.57E-05	4.31E-04
4320	2.18E-04	3.91E-04
4350	2.77E-04	6.83E-05
4380	4.72E-04	3.96E-05
4410	2.41E-04	(3.95E-05)
4440	3.31E-04	(3.94E-05)
4470	(3.30E-04)	(3.93E-05)
4500	(3.29E-04)	(3.92E-05)

FIRST DATA ALT 450 450

LAST DATA ALT 4440 4380

FLIGHT NO. C-398
EQUIVALENT ATTENUATION LENGTH

(JOB 4335 DATE 06/24/77)
 DATE 120276 FLIGHT NO. C-398 GROUND LEVEL ALTITUDE (M)= 46

ALTITUDE (M)	EQUIVALENT ATTENUATION LENGTH (M)	
	FILTERS 2	4
0	9.52E 03	1.76E 04
300	9.66E 03	1.79E 04
600	9.75E 03	1.83E 04
900	9.85E 03	1.85E 04
1200	1.02E 04	1.87E 04
1500	1.11E 04	2.03E 04
1800	1.20E 04	2.21E 04
2100	1.28E 04	2.37E 04
2400	1.36E 04	2.50E 04
2700	1.43E 04	2.61E 04
3000	1.49E 04	2.70E 04
3300	1.55E 04	2.79E 04
3600	1.60E 04	2.87E 04
3900	1.65E 04	2.95E 04
4200	1.66E 04	3.03E 04
4500	1.41E 04	2.47E 04

FLIGHT NO. C-398
VERTICAL BEAM TRANSMITTANCE FROM GROUND TO ALTITUDE

ALTITUDE (M)	VERTICAL BEAM TRANSMITTANCE FROM GROUND TO ALTITUDE	
	FILTERS 2	4
0	1.00E 00	1.00E 00
300	9.69E-01	9.83E-01
600	9.40E-01	9.68E-01
900	9.13E-01	9.53E-01
1200	8.89E-01	9.38E-01
1500	8.74E-01	9.29E-01
1800	8.61E-01	9.22E-01
2100	8.49E-01	9.15E-01
2400	8.38E-01	9.08E-01
2700	8.28E-01	9.02E-01
3000	8.18E-01	8.95E-01
3300	8.08E-01	8.88E-01
3600	7.99E-01	8.82E-01
3900	7.90E-01	8.76E-01
4200	7.77E-01	8.70E-01
4500	7.26E-01	8.34E-01

FLIGHT C-399 – 3 DECEMBER 1976 – DESCRIPTION OF FLIGHT AND WEATHER CHARACTERISTICS

Filter Ident	Data Interval			Solar Zenith Angle			Flight Altitude (meters)		Average Terrain Elevation (meters)
	Start (GMT)	End (GMT)	Elapsed (hrs) (min)	Initial (degrees)	Solar Transit (degrees)	Final (degrees)	(min)	(max)	
2,3	1013	1250	2 37	73.9	70.2	71.2	390	2610	46
4,5	1116	1230	1 14	70.8	70.2	70.6	420	2580	46

Flight C-399 was a midday flight spanning local apparent noon. Scattered low clouds and high overcast were present throughout.

The approximate east to west Bruz track was centered south of Rennes in northwestern France. Typical terrain features were green fields interspersed with brown areas and dark green trees.

The in-flight observer reported stratocumulus varying from 1/8 to 3/8 at 690 meters (2300 feet) and overcast cirrus at 6900 meters (23000 feet). The cirrus layer was sometimes thin and the east end of the track had better conditions than the west end. At 1205 GMT at the west end of the track the 690-meter deck was a heavy overcast. There was light haze, with no marked haze tops below 2850 meters (9500 feet), the maximum aircraft altitude.

Rennes/St. Jacques, north of the center of the track, had observations of cumulonimbus varying from 3/8 to 6/8 coverage and altitudes of 600 to 690 meters (2000 to 2300 feet), 7/8 cirrus at 6900 meters (23000 feet) and visibility 11.2 to 25 kilometers.

St. Nazaire-Montoir, south of the track, reported 2/8 to 3/8 cumulonimbus at 600 meters (2000 feet) and 6/8 to 7/8 cirrus at 6900 meters (23000 feet). Visibility was 11.2 to 15 kilometers with light rain showers reported at 1100 and 1200 GMT.

Nantès-Chateau Bougon, south of the track center, reported 2/8 to 3/8 cumulonimbus at 600 meters (2000 feet), 6/8 to 7/8 altocumulus at 3000 meters (10000 feet), 7/8 cirrus at 7500 meters (25000 feet) and visibility 11.2 to 30 kilometers.

Anbers/Avrille, southeast of the track, reported 2/8 of cumulus and stratocumulus at 600 meters (2000 feet) becoming cumulonimbus at 1400 GMT. There were also 7/8 altostratus at 3000 meters (10000 feet) and 5/8 cirrus at 6900 meters (23000 feet). Visibility was 11.2 to 15 kilometers.

The radiosonde station at Brest was approximately 200 kilometers westnorthwest of the center of the track. The radiosonde station was upstream from the track.

The surface chart for 1200 GMT had a complex low over Europe and the eastern Atlantic with a 973-millibar low over Ireland and another in the North Sea. A cold front, part of this system, extended from the Black Sea through the heel of Italy then westsouthwest to southern Spain then southwest into the Atlantic. At 500 millibars there was a low in the North Sea with the trough axis southeast to Romania. Moderate westerly flow was over the flight area. The airmass was unstable maritime polar.

FLIGHT NO. C-399

BRUZ

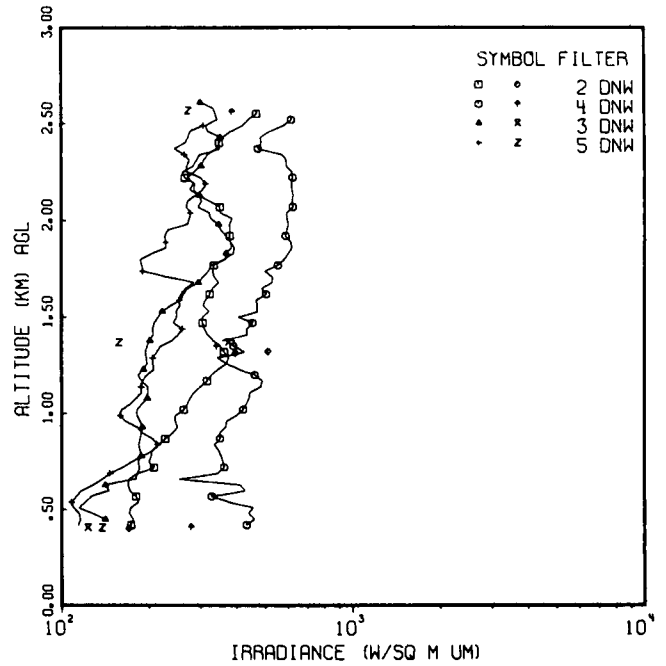
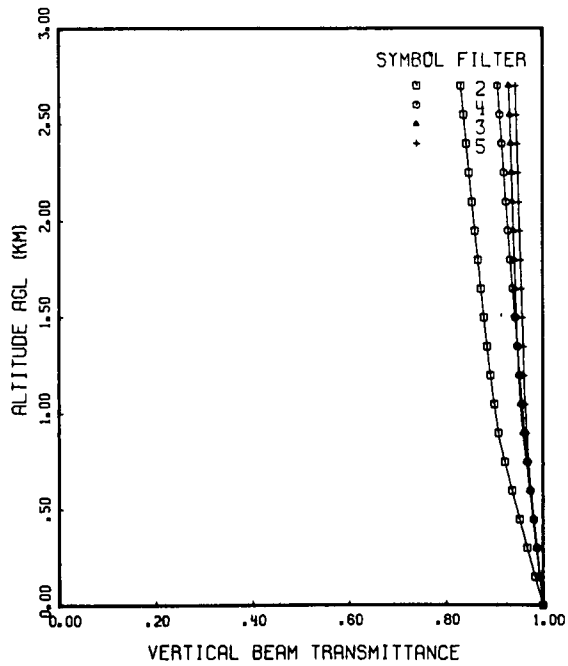
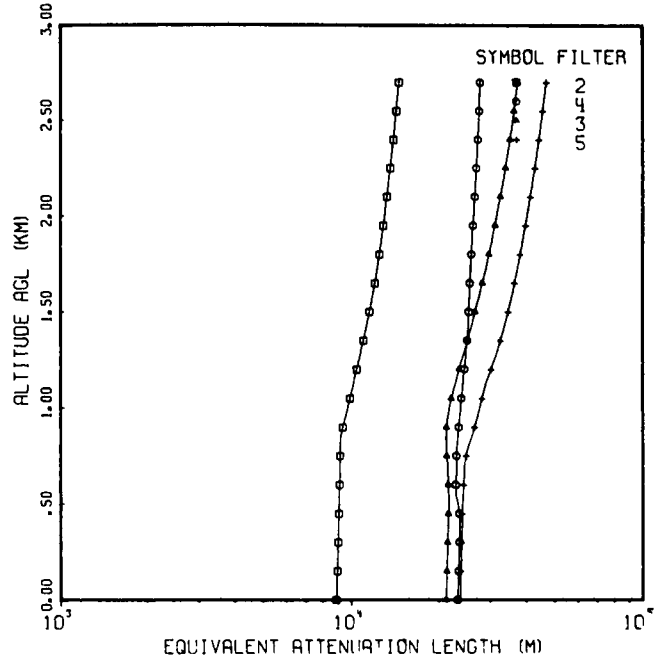
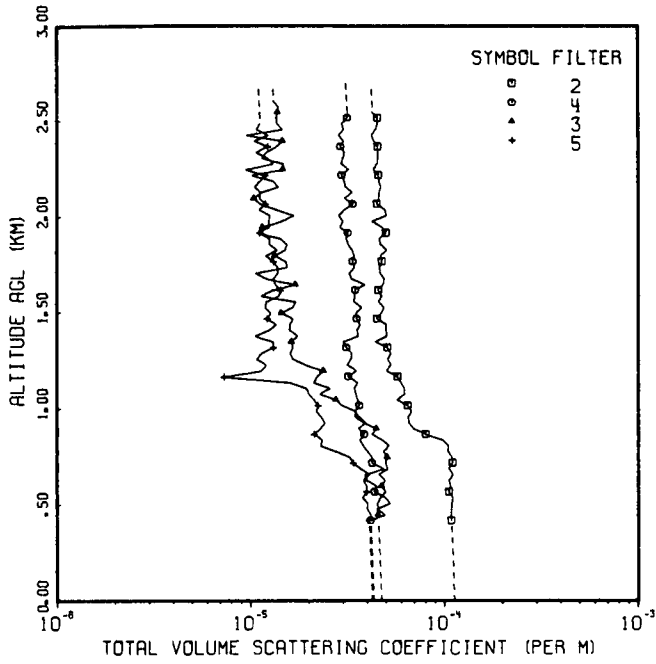

FLIGHT NO. C-399

TOTAL VOLUME SCATTERING COEFFICIENT

(JOB 2366 DATE 10/03/77)
 DATE 120376 FLIGHT NO. C-399 GROUND LEVEL ALTITUDE (M)= 46

ALTITUDE (M)	TOTAL VOLUME SCATTERING COEFFICIENT (PER M)			
	FILTERS	2	4	3
0	(1.13E-04)	(4.32E-05)	(4.74E-05)	(4.24E-05)
30	(1.12E-04)	(4.30E-05)	(4.72E-05)	(4.22E-05)
60	(1.12E-04)	(4.29E-05)	(4.71E-05)	(4.21E-05)
90	(1.12E-04)	(4.28E-05)	(4.70E-05)	(4.20E-05)
120	(1.11E-04)	(4.27E-05)	(4.69E-05)	(4.19E-05)
150	(1.11E-04)	(4.26E-05)	(4.67E-05)	(4.18E-05)
180	(1.11E-04)	(4.25E-05)	(4.66E-05)	(4.17E-05)
210	(1.11E-04)	(4.24E-05)	(4.65E-05)	(4.16E-05)
240	(1.10E-04)	(4.23E-05)	(4.64E-05)	(4.15E-05)
270	(1.10E-04)	(4.21E-05)	(4.63E-05)	(4.14E-05)
300	(1.10E-04)	(4.20E-05)	(4.61E-05)	(4.13E-05)
330	(1.09E-04)	(4.19E-05)	(4.60E-05)	(4.12E-05)
360	(1.09E-04)	(4.18E-05)	(4.59E-05)	(4.10E-05)
390	(1.09E-04)	(4.17E-05)	(4.58E-05)	(4.09E-05)
420	1.08E-04	4.16E-05	(4.56E-05)	4.08E-05
450	1.08E-04	4.95E-05	4.55E-05	4.19E-05
480	1.08E-04	4.46E-05	4.54E-05	4.00E-05
510	1.09E-04	5.25E-05	4.52E-05	4.03E-05
540	1.11E-04	4.95E-05	4.68E-05	3.79E-05
570	1.05E-04	4.35E-05	5.00E-05	3.97E-05
600	1.08E-04	4.48E-05	4.75E-05	3.77E-05
630	1.05E-04	3.96E-05	4.96E-05	3.82E-05
660	1.11E-04	3.89E-05	4.58E-05	4.11E-05
690	1.05E-04	4.86E-05	5.10E-05	3.69E-05
720	1.10E-04	4.23E-05	4.97E-05	3.38E-05
750	1.09E-04	4.24E-05	5.07E-05	3.26E-05
780	1.04E-04	4.00E-05	4.86E-05	2.76E-05
810	1.05E-04	3.82E-05	5.19E-05	2.30E-05
840	4.76E-05	3.66E-05	4.76E-05	2.34E-05
870	7.99E-05	3.85E-05	4.25E-05	2.12E-05
900	6.91E-05	3.61E-05	4.45E-05	2.29E-05
930	6.55E-05	3.92E-05	3.83E-05	2.42E-05
960	6.49E-05	3.64E-05	3.46E-05	2.32E-05
990	6.77E-05	3.47E-05	3.49E-05	2.18E-05
1020	6.46E-05	3.64E-05	2.96E-05	2.23E-05
1050	5.70E-05	3.56E-05	2.75E-05	2.13E-05
1080	6.25E-05	3.48E-05	2.27E-05	2.00E-05
1110	6.19E-05	3.43E-05	2.57E-05	1.95E-05
1140	5.98E-05	3.57E-05	2.12E-05	1.60E-05
1170	5.72E-05	3.19E-05	2.21E-05	7.29E-06
1200	5.03E-05	3.53E-05	2.37E-05	1.14E-05
1230	5.30E-05	3.16E-05	1.92E-05	1.21E-05
1260	5.10E-05	3.30E-05	1.65E-05	1.08E-05
1290	5.31E-05	3.34E-05	1.60E-05	1.14E-05
1320	5.07E-05	3.12E-05	1.65E-05	1.31E-05
1350	4.40E-05	3.01E-05	1.63E-05	1.31E-05
1380	5.04E-05	3.60E-05	1.75E-05	1.06E-05
1410	5.02E-05	3.55E-05	1.59E-05	1.24E-05
1440	5.01E-05	3.69E-05	1.60E-05	1.36E-05
1470	4.49E-05	3.52E-05	1.66E-05	1.22E-05
1500	4.73E-05	3.50E-05	1.44E-05	1.28E-05

FLIGHT NO. C-399
TOTAL VOLUME SCATTERING COEFFICIENT

(JOB 2366 DATE 10/03/77)
 DATE 120376 FLIGHT NO. C-399 GROUND LEVEL ALTITUDE (M)= 46

ALTITUDE (M)	TOTAL VOLUME SCATTERING COEFFICIENT (PER M)				
	FILTERS	2	4	3	5
1530		4.90E-05	3.75E-05	1.65E-05	1.19E-05
1560		4.57E-05	3.42E-05	1.71E-05	1.21E-05
1590		4.77E-05	3.46E-05	1.14E-05	1.40E-05
1620		4.56E-05	3.47E-05	1.30E-05	1.43E-05
1650		4.84E-05	3.89E-05	1.70E-05	1.35E-05
1680		4.91E-05	3.32E-05	1.21E-05	1.32E-05
1710		4.67E-05	3.25E-05	1.06E-05	1.38E-05
1740		4.63E-05	3.45E-05	1.55E-05	1.39E-05
1770		4.76E-05	3.37E-05	1.52E-05	1.31E-05
1800		4.69E-05	3.44E-05	1.33E-05	1.20E-05
1830		5.06E-05	3.35E-05	1.51E-05	1.37E-05
1860		4.68E-05	3.20E-05	1.55E-05	1.25E-05
1890		4.64E-05	3.13E-05	1.42E-05	1.26E-05
1920		4.99E-05	3.18E-05	1.11E-05	1.11E-05
1950		4.77E-05	2.89E-05	1.15E-05	1.25E-05
1980		4.24E-05	3.01E-05	1.45E-05	1.24E-05
2010		5.03E-05	2.86E-05	1.68E-05	1.27E-05
2040		4.95E-05	3.06E-05	1.37E-05	1.11E-05
2070		4.49E-05	3.38E-05	1.12E-05	1.20E-05
2100		4.61E-05	3.07E-05	1.04E-05	1.12E-05
2130		4.61E-05	3.36E-05	1.15E-05	1.13E-05
2160		4.72E-05	3.10E-05	1.40E-05	1.05E-05
2190		4.61E-05	3.05E-05	1.31E-05	1.13E-05
2220		4.58E-05	2.96E-05	1.01E-05	1.19E-05
2250		4.32E-05	3.22E-05	1.48E-05	9.49E-06
2280		4.52E-05	2.94E-05	1.48E-05	1.32E-05
2310		4.54E-05	3.01E-05	1.14E-05	1.23E-05
2340		4.54E-05	3.08E-05	1.21E-05	1.07E-05
2370		4.54E-05	2.92E-05	1.36E-05	1.23E-05
2400		4.33E-05	3.03E-05	1.47E-05	1.05E-05
2430		4.22E-05	2.85E-05	9.54E-06	1.24E-05
2460		4.43E-05	3.03E-05	1.47E-05	1.08E-05
2490		4.53E-05	2.96E-05	1.37E-05	1.12E-05
2520		4.51E-05	3.16E-05	1.37E-05	(1.12E-05)
2550		4.26E-05	(3.15E-05)	1.38E-05	(1.11E-05)
2580	(4.24E-05)		(3.14E-05)	1.40E-05	(1.11E-05)
2610	(4.23E-05)		(3.13E-05)	1.31E-05	(1.11E-05)
2640	(4.22E-05)		(3.12E-05)	(1.31E-05)	(1.10E-05)
2670	(4.20E-05)		(3.11E-05)	(1.31E-05)	(1.10E-05)
2700	(4.19E-05)		(3.10E-05)	(1.30E-05)	(1.10E-05)
FIRST DATA ALT		420	420	450	420
LAST DATA ALT		2550	2520	2610	2490

FLIGHT NO. C-399
EQUIVALENT ATTENUATION LENGTH

(JOB 2366 DATE 10/03/77)
 DATE 120376 FLIGHT NO. C-399 GROUND LEVEL ALTITUDE (M)= 46

ALTITUDE (M)	EQUIVALENT ATTENUATION LENGTH (M)				
	FILTERS	2	4	3	5
0	8.87E 03	2.31E 04	2.11E 04	2.36E 04	
300	9.00E 03	2.35E 04	2.14E 04	2.39E 04	
600	9.10E 03	2.28E 04	2.15E 04	2.43E 04	
900	9.34E 03	2.34E 04	2.12E 04	2.65E 04	
1200	1.04E 04	2.44E 04	2.35E 04	3.02E 04	
1500	1.15E 04	2.53E 04	2.67E 04	3.46E 04	
1800	1.25E 04	2.59E 04	2.98E 04	3.80E 04	
2100	1.33E 04	2.66E 04	3.25E 04	4.12E 04	
2400	1.40E 04	2.72E 04	3.51E 04	4.41E 04	
2700	1.46E 04	2.77E 04	3.73E 04	4.67E 04	

FLIGHT NO. C-399
VERTICAL BEAM TRANSMITTANCE FROM GROUND TO ALTITUDE

ALTITUDE (M)	VERTICAL BEAM TRANSMITTANCE FROM GROUND TO ALTITUDE				
	FILTERS	2	4	3	5
0	1.00E 00	1.00E 00	1.00E 00	1.00E 00	
300	9.67E-01	9.87E-01	9.86E-01	9.88E-01	
600	9.36E-01	9.74E-01	9.72E-01	9.76E-01	
900	9.08E-01	9.62E-01	9.58E-01	9.67E-01	
1200	8.91E-01	9.52E-01	9.50E-01	9.61E-01	
1500	8.78E-01	9.42E-01	9.45E-01	9.58E-01	
1800	8.66E-01	9.33E-01	9.41E-01	9.54E-01	
2100	8.54E-01	9.24E-01	9.37E-01	9.50E-01	
2400	8.42E-01	9.16E-01	9.34E-01	9.47E-01	
2700	8.31E-01	9.07E-01	9.30E-01	9.44E-01	

FLIGHT C-400 – 4 DECEMBER 1976 – DESCRIPTION OF FLIGHT AND WEATHER CHARACTERISTICS

Filter Ident	Data Interval			Solar Zenith Angle			Flight Altitude (meters)		Average Terrain Elevation (meters)
	Start (GMT)	End (GMT)	Elapsed (hrs) (min)	Initial (degrees)	Solar Transit (degrees)	Final (degrees)	(min)	(max)	
2,3	1029	1204	1 35	73.0	70.3	70.3	480	5100	46
4	1219	1233	0 14	70.5	–	70.8	480	5070	46
5	1250	1305	0 15	71.3	–	72.0	480	5100	46

Flight C-400 was a midday flight. Multiple cloud layers with nonuniform obscuration restricted the flight to V-Pro's.

The approximate east to west Bruz track was centered south of Rennes in northwestern France. Typical terrain features were green fields interspersed with brown areas and dark green trees.

The in-flight observer reported overcast cirrus with sun disc obscured. Scattered scud at 300 meters (1000 feet) and light to moderate haze were also present.

Rennes/St. Jacques, north of the center of the track, reported 1/8 to 2/8 cumulonimbus at 450 meters (1500 feet) and 3/8 to 5/8 cirrus at 6900 to 7500 meters (23 000 to 25 000 feet). Visibility was mostly 11.2 kilometers but was reported at 1200 GMT as 35 kilometers.

St. Nazaire-Montoir, south of the track, reported conditions similar to Rennes/St. Jacques.

Nantes-Chateau Bougon, south of the track center, had 2/8 cumulonimbus at 750 meters (2500 feet) and 4/8 to 5/8 cirrus at 6900 meters (23 000 feet). Visibility was 11.2 kilometers but improved to 30.0 kilometers at the 1200 GMT observation.

Anbers/Avrille, southeast of the track, reported 3/8 to 7/8 cumulonimbus at 900 meters (3000 feet) and 3/8 to 5/8 cirrus at 7500 meters (25 000 feet). Visibility varied from 11.2 to 20 kilometers.

The radiosonde station at Brest was approximately 200 kilometers westnorthwest of the center of the track. The radiosonde station was upstream from the track.

At 1200 GMT the surface chart had a 970-millibar low centered between Norway and Denmark with a frontal system southeast into Russia. A secondary low of 987 millibars was centered in the Adriatic and had a cold front extending southwest into Algeria. A trough extended from Marseille to Valencia and Gibraltar. Another deepening storm center with accompanying fronts caused all of the area north of 40N to be affected by low pressures. At 500 millibars there was a low over Denmark with a trough southsouthwestward to Algeria. There was moderate westnorthwest flow over the flight region. The airmass was unstable maritime polar.

FLIGHT NO. C-400

BRUZ

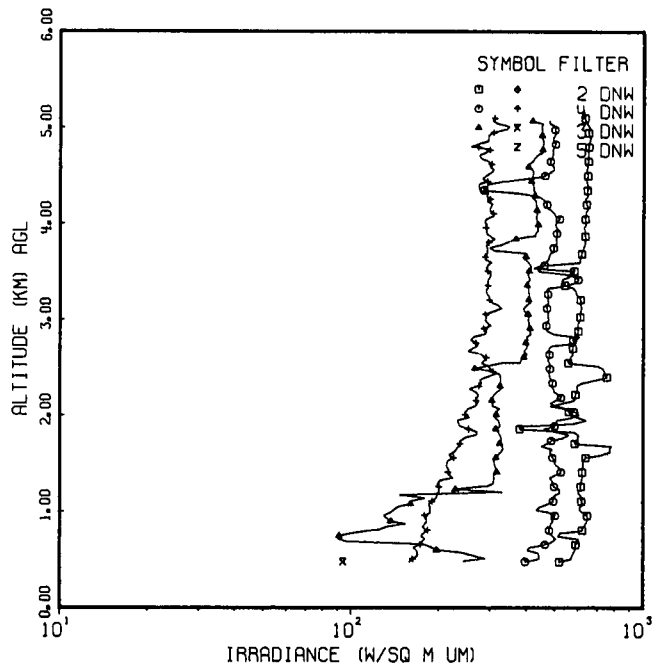
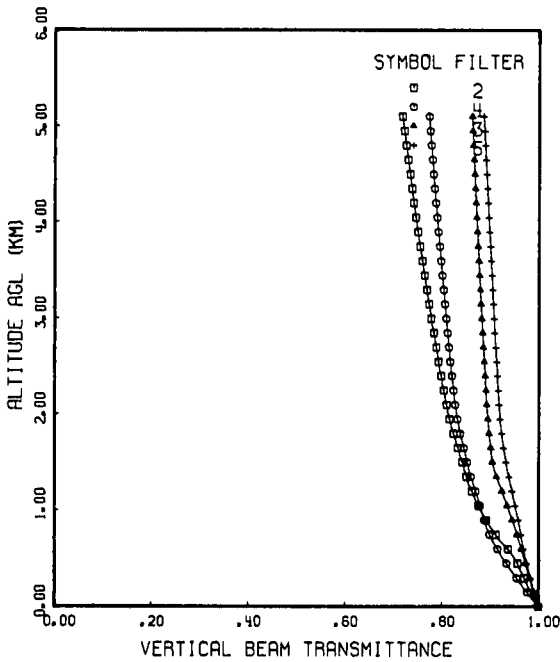
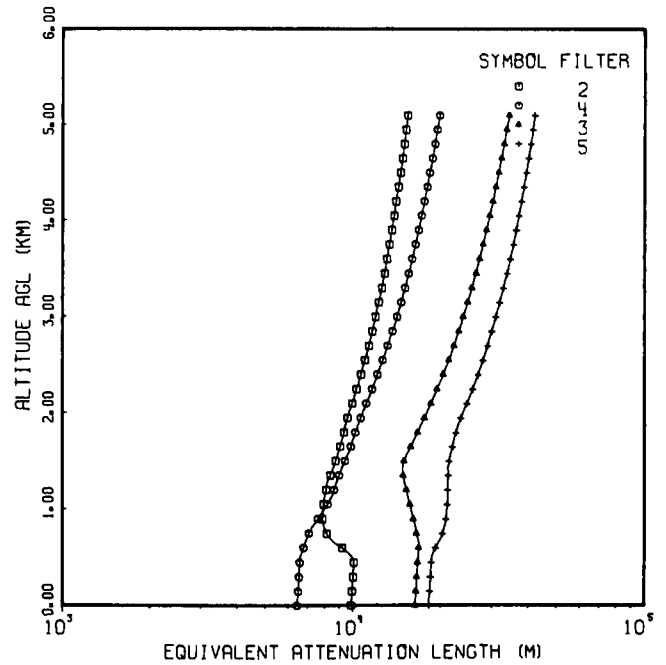
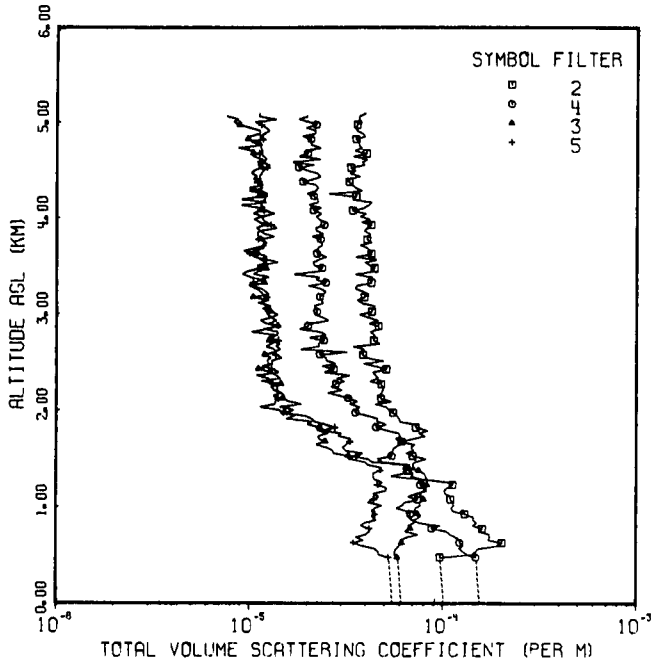

FLIGHT NO. C-400
TOTAL VOLUME SCATTERING COEFFICIENT

(JOB 2288 DATE 10/03/77)
 DATE 120476 FLIGHT NO. C-400 GROUND LEVEL ALTITUDE (M)= 46

ALTITUDE (M)	TOTAL VOLUME SCATTERING COEFFICIENT (PER M)			
	FILTERS 2	4	3	5
0	(1.01E-04)	(1.55E-04)	(6.12E-05)	(5.49E-05)
30	(1.01E-04)	(1.55E-04)	(6.09E-05)	(5.47E-05)
60	(1.01E-04)	(1.54E-04)	(6.08E-05)	(5.45E-05)
90	(1.00E-04)	(1.54E-04)	(6.06E-05)	(5.44E-05)
120	(1.00E-04)	(1.53E-04)	(6.04E-05)	(5.43E-05)
150	(9.98E-05)	(1.53E-04)	(6.03E-05)	(5.41E-05)
180	(9.96E-05)	(1.53E-04)	(6.01E-05)	(5.40E-05)
210	(9.93E-05)	(1.52E-04)	(6.00E-05)	(5.38E-05)
240	(9.91E-05)	(1.52E-04)	(5.98E-05)	(5.37E-05)
270	(9.88E-05)	(1.52E-04)	(5.97E-05)	(5.36E-05)
300	(9.86E-05)	(1.51E-04)	(5.95E-05)	(5.34E-05)
330	(9.83E-05)	(1.51E-04)	(5.94E-05)	(5.33E-05)
360	(9.80E-05)	(1.50E-04)	(5.92E-05)	(5.31E-05)
390	(9.78E-05)	(1.50E-04)	(5.90E-05)	(5.30E-05)
420	(9.75E-05)	(1.50E-04)	(5.89E-05)	(5.28E-05)
450	(9.72E-05)	(1.49E-04)	(5.87E-05)	(5.27E-05)
480	9.70E-05	1.49E-04	5.86E-05	5.26E-05
510	1.43E-04	1.33E-04	5.64E-05	4.67E-05
540	1.49E-04	1.27E-04	5.65E-05	4.64E-05
570	1.55E-04	1.21E-04	5.78E-05	4.44E-05
600	1.92E-04	1.28E-04	5.99E-05	3.79E-05
630	2.03E-04	1.23E-04	6.17E-05	3.46E-05
660	1.72E-04	1.24E-04	6.05E-05	3.90E-05
690	1.75E-04	1.17E-04	6.59E-05	3.54E-05
720	1.75E-04	1.09E-04	7.51E-05	4.02E-05
750	1.54E-04	1.05E-04	6.40E-05	4.20E-05
780	1.60E-04	8.77E-05	6.82E-05	4.18E-05
810	1.43E-04	9.76E-05	6.64E-05	3.77E-05
840	1.50E-04	7.61E-05	7.14E-05	3.96E-05
870	1.43E-04	6.91E-05	7.12E-05	4.53E-05
900	1.44E-04	6.65E-05	7.66E-05	4.31E-05
930	1.30E-04	6.79E-05	7.43E-05	4.48E-05
960	1.13E-04	6.54E-05	7.20E-05	4.28E-05
990	1.11E-04	5.73E-05	7.20E-05	4.44E-05
1020	1.14E-04	6.21E-05	7.71E-05	4.85E-05
1050	1.13E-04	6.42E-05	7.59E-05	4.09E-05
1080	1.10E-04	7.41E-05	7.98E-05	4.39E-05
1110	1.10E-04	6.63E-05	7.82E-05	4.70E-05
1140	1.03E-04	7.34E-05	7.64E-05	4.36E-05
1170	1.02E-04	8.28E-05	7.94E-05	5.09E-05
1200	1.06E-04	8.20E-05	8.12E-05	5.14E-05
1230	1.13E-04	7.67E-05	8.29E-05	4.60E-05
1260	1.07E-04	8.03E-05	7.52E-05	4.89E-05
1290	8.01E-05	7.63E-05	8.32E-05	4.41E-05
1320	5.38E-05	6.86E-05	8.16E-05	4.36E-05
1350	6.23E-05	7.04E-05	8.01E-05	4.35E-05
1380	6.51E-05	6.65E-05	7.50E-05	4.75E-05
1410	7.17E-05	6.25E-05	6.76E-05	4.85E-05
1440	6.93E-05	6.76E-05	6.77E-05	4.10E-05
1470	7.25E-05	4.82E-05	4.28E-05	3.92E-05
1500	8.23E-05	4.59E-05	4.07E-05	3.25E-05

FLIGHT NO. C-400
TOTAL VOLUME SCATTERING COEFFICIENT

{JOB 2288 DATE 10/03/77}
 DATE 120476 FLIGHT NO. C-400 GROUND LEVEL ALTITUDE (M)= 46

ALTITUDE (M)	TOTAL VOLUME SCATTERING COEFFICIENT (PER M)				
	FILTERS	2	4	3	5
1530		6.98E-05	5.44E-05	3.26E-05	3.55E-05
1560		6.46E-05	5.38E-05	2.71E-05	3.87E-05
1590		7.08E-05	5.51E-05	2.68E-05	3.13E-05
1620		6.82E-05	5.64E-05	2.49E-05	3.02E-05
1650		7.18E-05	5.95E-05	2.21E-05	3.17E-05
1680		6.12E-05	6.12E-05	2.47E-05	3.31E-05
1710		6.97E-05	5.69E-05	2.28E-05	3.34E-05
1740		8.12E-05	6.06E-05	2.26E-05	2.88E-05
1770		7.52E-05	5.90E-05	2.55E-05	2.98E-05
1800		8.38E-05	5.16E-05	2.25E-05	2.39E-05
1830		7.25E-05	4.52E-05	2.31E-05	2.76E-05
1860		7.44E-05	5.12E-05	2.00E-05	2.46E-05
1890		5.98E-05	4.57E-05	2.11E-05	2.16E-05
1920		5.97E-05	4.60E-05	1.55E-05	2.09E-05
1950		5.79E-05	4.10E-05	1.71E-05	1.93E-05
1980		5.51E-05	3.53E-05	1.53E-05	1.50E-05
2010		5.23E-05	3.55E-05	1.70E-05	1.41E-05
2040		5.10E-05	3.70E-05	1.43E-05	1.13E-05
2070		4.48E-05	3.29E-05	1.87E-05	1.35E-05
2100		5.42E-05	3.62E-05	1.58E-05	1.36E-05
2130		4.77E-05	3.23E-05	1.49E-05	1.41E-05
2160		4.69E-05	2.93E-05	1.51E-05	1.33E-05
2190		4.81E-05	2.54E-05	1.46E-05	1.44E-05
2220		4.93E-05	3.01E-05	1.33E-05	1.38E-05
2250		4.87E-05	2.64E-05	1.29E-05	1.39E-05
2280		4.79E-05	2.79E-05	1.45E-05	1.32E-05
2310		4.19E-05	3.10E-05	1.14E-05	1.29E-05
2340		4.64E-05	2.83E-05	1.45E-05	1.25E-05
2370		4.48E-05	3.30E-05	1.37E-05	1.09E-05
2400		4.32E-05	2.43E-05	1.29E-05	1.42E-05
2430		5.08E-05	2.72E-05	1.11E-05	1.30E-05
2460		4.51E-05	2.37E-05	1.26E-05	1.16E-05
2490		3.87E-05	2.78E-05	1.25E-05	1.32E-05
2520		4.92E-05	2.50E-05	1.23E-05	1.30E-05
2550		4.07E-05	2.49E-05	1.29E-05	1.47E-05
2580		3.84E-05	2.30E-05	1.20E-05	1.36E-05
2610		3.77E-05	3.22E-05	1.35E-05	1.37E-05
2640		3.91E-05	1.83E-05	1.44E-05	1.34E-05
2670		3.43E-05	2.24E-05	1.37E-05	1.21E-05
2700		4.74E-05	2.26E-05	1.43E-05	1.30E-05
2730		4.38E-05	2.42E-05	1.26E-05	1.41E-05
2760		4.41E-05	2.04E-05	1.29E-05	1.24E-05
2790		4.43E-05	2.48E-05	1.39E-05	1.39E-05
2820		4.18E-05	2.30E-05	1.40E-05	1.02E-05
2850		4.68E-05	1.81E-05	1.18E-05	1.24E-05
2880		4.62E-05	2.00E-05	1.40E-05	1.39E-05
2910		4.14E-05	2.09E-05	1.26E-05	1.21E-05
2940		4.63E-05	2.57E-05	1.38E-05	1.13E-05
2970		4.12E-05	2.37E-05	1.29E-05	1.30E-05
3000		3.70E-05	2.15E-05	1.39E-05	1.22E-05

FLIGHT NO. C-400

TOTAL VOLUME SCATTERING COEFFICIENT

(JOB 2288 DATE 10/03/77)
 DATE 120476 FLIGHT NO. C-400 GROUND LEVEL ALTITUDE (M)= 46

ALTITUDE (M)	TOTAL VOLUME SCATTERING COEFFICIENT (PER M)				
	FILTERS	2	4	3	5
3030		4.27E-05	2.23E-05	1.28E-05	1.25E-05
3060		4.35E-05	2.19E-05	1.17E-05	1.18E-05
3090		4.44E-05	2.15E-05	1.28E-05	1.24E-05
3120		3.79E-05	2.41E-05	1.10E-05	1.15E-05
3150		3.58E-05	2.35E-05	1.25E-05	1.22E-05
3180		3.91E-05	2.30E-05	1.04E-05	1.23E-05
3210		4.14E-05	2.40E-05	1.26E-05	1.17E-05
3240		3.86E-05	2.48E-05	1.20E-05	1.13E-05
3270		3.51E-05	2.30E-05	1.14E-05	1.07E-05
3300		3.57E-05	2.01E-05	1.02E-05	9.85E-06
3330		4.24E-05	2.47E-05	1.19E-05	1.04E-05
3360		4.19E-05	2.21E-05	1.11E-05	1.15E-05
3390		4.28E-05	2.29E-05	1.25E-05	1.00E-05
3420		3.52E-05	1.68E-05	1.04E-05	9.13E-06
3450		4.33E-05	2.32E-05	1.11E-05	9.71E-06
3480		4.41E-05	2.37E-05	1.21E-05	1.13E-05
3510		4.18E-05	2.15E-05	1.12E-05	1.10E-05
3540		3.92E-05	2.11E-05	1.22E-05	1.41E-05
3570		4.51E-05	2.28E-05	1.12E-05	1.21E-05
3600		3.52E-05	2.44E-05	1.23E-05	1.05E-05
3630		4.24E-05	2.22E-05	1.10E-05	9.93E-06
3660		4.15E-05	2.23E-05	9.25E-06	1.05E-05
3690		4.06E-05	2.24E-05	1.07E-05	1.19E-05
3720		3.71E-05	2.38E-05	1.22E-05	1.16E-05
3750		4.25E-05	2.31E-05	1.19E-05	1.23E-05
3780		4.02E-05	2.32E-05	1.14E-05	1.11E-05
3810		4.11E-05	2.10E-05	1.11E-05	1.34E-05
3840		4.19E-05	2.39E-05	1.09E-05	1.18E-05
3870		3.89E-05	2.21E-05	1.14E-05	1.12E-05
3900		4.06E-05	2.18E-05	1.07E-05	1.38E-05
3930		4.24E-05	2.42E-05	1.20E-05	1.29E-05
3960		3.79E-05	2.41E-05	1.12E-05	1.21E-05
3990		4.17E-05	2.27E-05	1.05E-05	1.17E-05
4020		3.71E-05	2.19E-05	1.16E-05	1.16E-05
4050		3.99E-05	2.34E-05	1.04E-05	1.34E-05
4080		3.39E-05	2.12E-05	1.14E-05	1.19E-05
4110		3.89E-05	2.34E-05	1.14E-05	1.19E-05
4140		4.10E-05	2.02E-05	9.01E-06	1.14E-05
4170		4.26E-05	2.25E-05	1.22E-05	1.15E-05
4200		3.38E-05	2.23E-05	9.04E-06	1.21E-05
4230		3.53E-05	2.14E-05	1.11E-05	1.19E-05
4260		2.56E-05	1.96E-05	1.24E-05	1.19E-05
4290		3.81E-05	2.19E-05	1.13E-05	9.92E-06
4320		3.50E-05	2.25E-05	9.93E-06	1.17E-05
4350		3.37E-05	2.18E-05	1.17E-05	1.10E-05
4380		3.24E-05	1.87E-05	1.09E-05	1.12E-05
4410		3.14E-05	2.13E-05	1.04E-05	1.14E-05
4440		3.71E-05	2.32E-05	1.09E-05	1.12E-05
4470		3.28E-05	2.21E-05	1.02E-05	1.14E-05
4500		3.52E-05	1.98E-05	1.05E-05	1.18E-05

FLIGHT NO. C-400
TOTAL VOLUME SCATTERING COEFFICIENT

(JOB 2288 DATE 10/03/77)
 DATE 120476 FLIGHT NO. C-400 GROUND LEVEL ALTITUDE (M)= 46

ALTITUDE (M)	FILTERS	TOTAL VOLUME SCATTERING COEFFICIENT (PER M)			
		2	4	3	5
4530	3.31E-05	1.78E-05	1.14E-05	1.22E-05	
4560	3.91E-05	2.15E-05	1.10E-05	1.27E-05	
4590	3.79E-05	1.66E-05	1.20E-05	1.09E-05	
4620	4.04E-05	2.32E-05	1.14E-05	1.22E-05	
4650	3.40E-05	1.79E-05	1.03E-05	1.18E-05	
4680	3.99E-05	1.98E-05	1.04E-05	1.12E-05	
4710	3.47E-05	1.95E-05	1.05E-05	1.17E-05	
4740	3.78E-05	2.32E-05	8.69E-06	1.14E-05	
4770	3.65E-05	2.07E-05	1.15E-05	1.14E-05	
4800	3.65E-05	2.06E-05	1.13E-05	1.02E-05	
4830	3.52E-05	2.06E-05	9.77E-06	1.17E-05	
4860	3.93E-05	1.86E-05	1.00E-05	1.12E-05	
4890	3.80E-05	2.16E-05	1.12E-05	1.19E-05	
4920	3.55E-05	2.18E-05	1.13E-05	1.26E-05	
4950	3.54E-05	1.94E-05	9.98E-06	1.21E-05	
4980	3.57E-05	2.19E-05	8.85E-06	1.15E-05	
5010	3.77E-05	2.00E-05	8.19E-06	1.06E-05	
5040	3.65E-05	1.78E-05	8.72E-06	1.36E-05	
5070	3.66E-05	1.97E-05	7.58E-06	1.12E-05	
5100	3.93E-05	(1.96E-05)	(7.56E-06)	1.12E-05	
FIRST DATA ALT	480	480	480	480	
LAST DATA ALT	5100	5070	5070	5100	

FLIGHT NO. C-400
EQUIVALENT ATTENUATION LENGTH

(JOB 2288 DATE 10/03/77)
 DATE 120476 FLIGHT NO. C-400 GROUND LEVEL ALTITUDE (M)= 46

ALTITUDE (M)	EQUIVALENT ATTENUATION LENGTH (M)			
	FILTERS 2	4	3	5
0	9.87E 03	6.43E 03	1.63E 04	1.82E 04
300	1.00E 04	6.53E 03	1.66E 04	1.85E 04
600	9.19E 03	6.78E 03	1.68E 04	1.92E 04
900	7.85E 03	7.58E 03	1.61E 04	2.09E 04
1200	8.08E 03	8.61E 03	1.52E 04	2.11E 04
1500	8.71E 03	9.39E 03	1.50E 04	2.14E 04
1800	9.30E 03	1.02E 04	1.67E 04	2.26E 04
2100	9.93E 03	1.11E 04	1.85E 04	2.46E 04
2400	1.06E 04	1.21E 04	2.04E 04	2.69E 04
2700	1.13E 04	1.31E 04	2.22E 04	2.90E 04
3000	1.19E 04	1.41E 04	2.39E 04	3.09E 04
3300	1.25E 04	1.51E 04	2.56E 04	3.28E 04
3600	1.31E 04	1.60E 04	2.72E 04	3.47E 04
3900	1.36E 04	1.68E 04	2.87E 04	3.63E 04
4200	1.40E 04	1.76E 04	3.02E 04	3.79E 04
4500	1.45E 04	1.83E 04	3.16E 04	3.94E 04
4800	1.50E 04	1.91E 04	3.30E 04	4.07E 04
5100	1.54E 04	1.98E 04	3.43E 04	4.20E 04

FLIGHT NO. C-400
VERTICAL BEAM TRANSMITTANCE FROM GROUND TO ALTITUDE

ALTITUDE (M)	VERTICAL BEAM TRANSMITTANCE FROM GROUND TO ALTITUDE			
	FILTERS 2	4	3	5
0	1.00E 00	1.00E 00	1.00E 00	1.00E 00
300	9.70E-01	9.55E-01	9.82E-01	9.84E-01
600	9.37E-01	9.15E-01	9.65E-01	9.69E-01
900	8.92E-01	8.88E-01	9.46E-01	9.58E-01
1200	8.62E-01	8.70E-01	9.24E-01	9.45E-01
1500	8.42E-01	8.52E-01	9.05E-01	9.32E-01
1800	8.24E-01	8.38E-01	8.98E-01	9.23E-01
2100	8.09E-01	8.28E-01	8.93E-01	9.18E-01
2400	7.98E-01	8.20E-01	8.89E-01	9.15E-01
2700	7.88E-01	8.14E-01	8.86E-01	9.11E-01
3000	7.78E-01	8.09E-01	8.82E-01	9.08E-01
3300	7.69E-01	8.03E-01	8.79E-01	9.04E-01
3600	7.59E-01	7.98E-01	8.76E-01	9.01E-01
3900	7.50E-01	7.93E-01	8.73E-01	8.98E-01
4200	7.41E-01	7.87E-01	8.70E-01	8.95E-01
4500	7.34E-01	7.82E-01	8.67E-01	8.92E-01
4800	7.26E-01	7.78E-01	8.64E-01	8.89E-01
5100	7.18E-01	7.73E-01	8.62E-01	8.86E-01

FLIGHT C-401 – 5 DECEMBER 1976 – DESCRIPTION OF FLIGHT AND WEATHER CHARACTERISTICS

Filter Ident	Data Interval			Solar Zenith Angle			Flight Altitude (meters)		Average Terrain Elevation (meters)
	Start (GMT)	End (GMT)	Elapsed (hrs) (min)	Initial (degrees)	Solar Transit (degrees)	Final (degrees)	(min)	(max)	
2,3	1040	1227	1 47	72 5	70 4	70 8	390	5190	46
4,5	1233	1428	1 55	70 9	–	78 2	420	5190	46

Flight C-401 was a midday flight spanning local apparent noon. Scattered cumulus and scattered thin cirrus did not interfere with collection of data.

The approximate east to west Bruz track was centered south of Rennes in northwestern France. Typical terrain features were green fields interspersed with some brown areas and dark green trees.

The in-flight observer noted thin scattered cirrus throughout the flight with scattered cumulus at 900 to 1050 meters (3000 to 3500 feet) forming after 1230 GMT. Multiple haze layers present in the morning became more dense in the afternoon.

Rennes/St. Jacques, north of the center of the track, reported 1/8 cumulus at 600 meters (2000 feet) and 1/8 to 2/8 thin cirrus at 7500 meters (25000 feet) throughout the period. Visibility was 11.2 to 35 kilometers.

St. Nazaire-Montoir, south of the track, reported 1/8 cumulus and stratocumulus at 600 meters (2000 feet) and 11.2-kilometer visibility at 0900 GMT. There were no other observations reported from this station.

Nantes-Chateau Bougon, south of the track, had 1/8 cumulus at 750 meters (2500 feet), 1/8 altocumulus at 4500 meters (15000 feet) and 1/8 thin cirrus at 7500 meters (25000 feet). Visibility ranged from 11.2 to 30 kilometers.

Anbers/Arville, southeast of the track, had 1/8 cumulus at 750 meters (2500 feet) and 1/8 thin cirrus at 7500 meters (25000 feet). Visibilities were 11.2 to 20 kilometers.

The radiosonde station at Brest was approximately 200 kilometers westnorthwest of the center of the track. The upper winds flowed from the region of the radiosonde station toward the track.

The surface chart for 1200 GMT showed that a complex low dominated northern Europe and the northern Atlantic. A 960-millibar low had an occlusion oriented 4 degrees west of the Irish coast and 8 degrees from western France. There was an open 995-millibar low located near Paris. Some weak ridging between the two lows occurred over the area of Rennes. At 500 millibars there was a low north of Bergen together with weak ridging off France and into southeastern Ireland and Great Britain. This pressure combination produced moderate northwesterly flow over the flight region. The airmass was unstable maritime polar.

FLIGHT NO. C-401

BRUZ

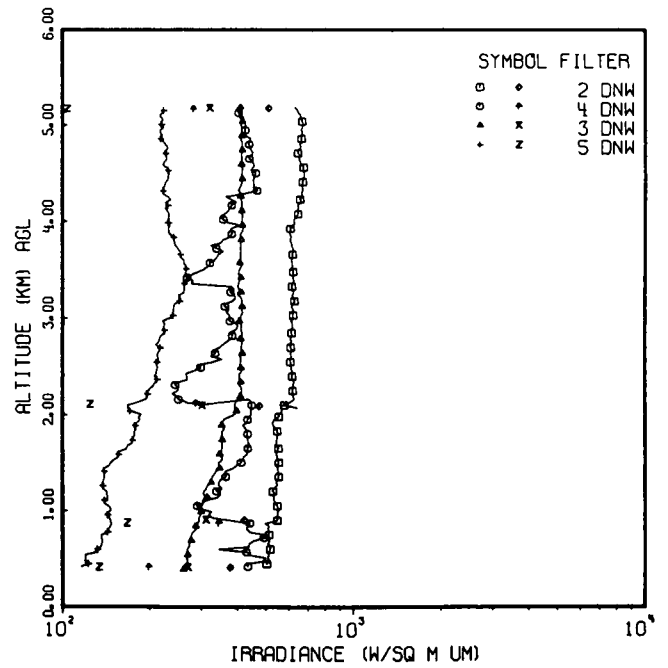
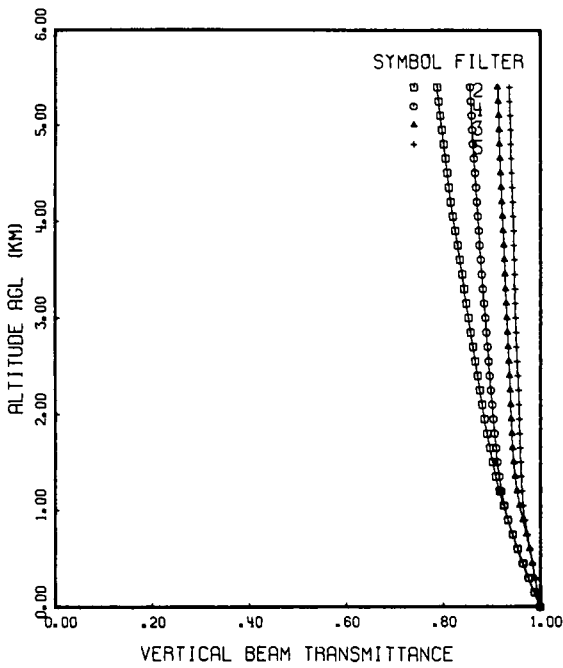
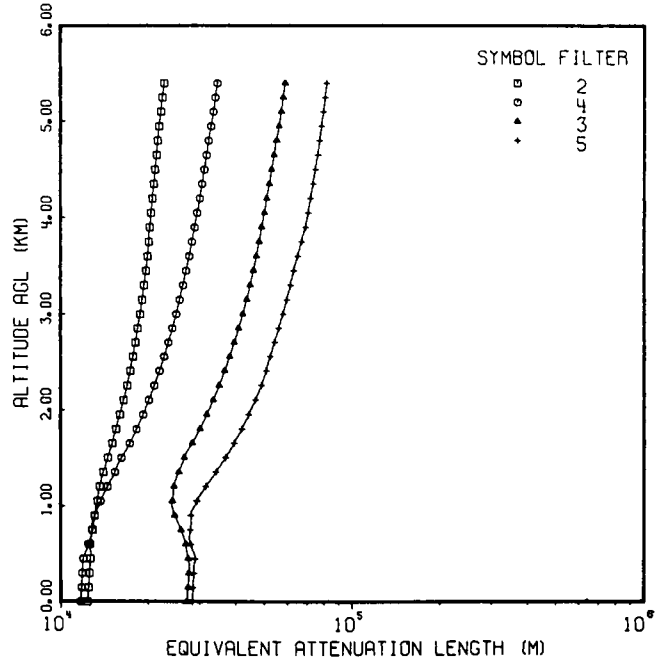
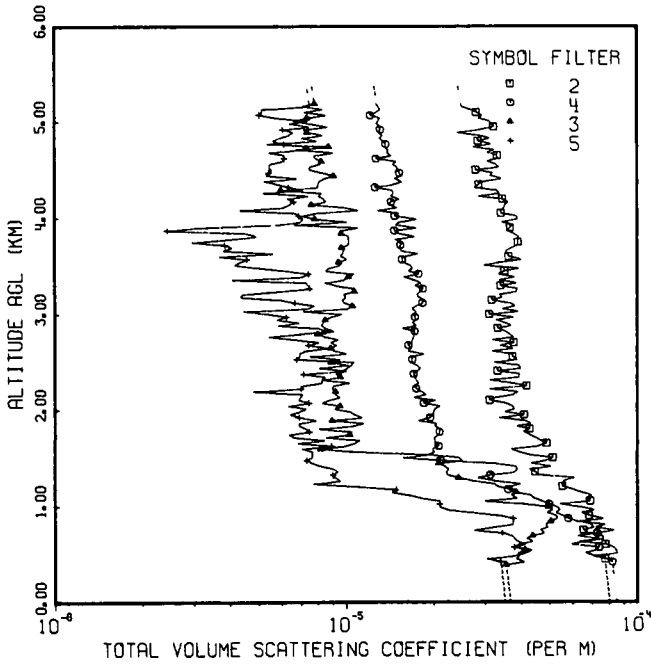

FLIGHT NO. C-401
TOTAL VOLUME SCATTERING COEFFICIENT

(JOB 4332 DATE 06/24/77)
 DATE 120576 FLIGHT NO. C-401 GROUND LEVEL ALTITUDE (M)= 46

ALTITUDE (M)	TOTAL VOLUME SCATTERING COEFFICIENT (PER M)				
	FILTERS	2	4	3	5
0		(8.07E-05)	(8.55E-05)	(3.68E-05)	(3.53E-05)
30		(8.03E-05)	(8.51E-05)	(3.66E-05)	(3.51E-05)
60		(8.01E-05)	(8.49E-05)	(3.65E-05)	(3.51E-05)
90		(7.99E-05)	(8.46E-05)	(3.64E-05)	(3.50E-05)
120		(7.97E-05)	(8.44E-05)	(3.63E-05)	(3.49E-05)
150		(7.95E-05)	(8.42E-05)	(3.62E-05)	(3.48E-05)
180		(7.93E-05)	(8.40E-05)	(3.61E-05)	(3.47E-05)
210		(7.91E-05)	(8.38E-05)	(3.61E-05)	(3.46E-05)
240		(7.89E-05)	(8.36E-05)	(3.60E-05)	(3.45E-05)
270		(7.87E-05)	(8.34E-05)	(3.59E-05)	(3.44E-05)
300		(7.85E-05)	(8.31E-05)	(3.58E-05)	(3.43E-05)
330		(7.83E-05)	(8.29E-05)	(3.57E-05)	(3.43E-05)
360		(7.81E-05)	(8.27E-05)	(3.56E-05)	(3.42E-05)
390		(7.79E-05)	(8.25E-05)	3.55E-05	(3.41E-05)
420		(7.77E-05)	8.22E-05	4.09E-05	3.40E-05
450		7.75E-05	7.87E-05	3.85E-05	3.04E-05
480		7.03E-05	7.15E-05	3.94E-05	3.76E-05
510		8.57E-05	6.63E-05	3.91E-05	4.14E-05
540		8.47E-05	7.22E-05	4.13E-05	4.36E-05
570		8.31E-05	7.40E-05	3.77E-05	3.78E-05
600		7.77E-05	5.94E-05	3.93E-05	4.14E-05
630		6.35E-05	6.57E-05	4.39E-05	3.88E-05
660		7.66E-05	7.42E-05	4.16E-05	3.80E-05
690		7.62E-05	6.24E-05	4.37E-05	3.73E-05
720		6.74E-05	7.29E-05	4.82E-05	3.44E-05
750		6.53E-05	8.33E-05	4.64E-05	2.75E-05
780		7.11E-05	7.19E-05	4.94E-05	3.19E-05
810		6.94E-05	7.73E-05	4.86E-05	3.74E-05
840		6.34E-05	6.17E-05	5.05E-05	3.75E-05
870		7.66E-05	5.78E-05	5.31E-05	3.76E-05
900		6.82E-05	5.52E-05	5.29E-05	3.33E-05
930		6.45E-05	5.25E-05	4.88E-05	2.73E-05
960		7.14E-05	5.44E-05	5.12E-05	2.23E-05
990		6.34E-05	5.31E-05	4.96E-05	2.10E-05
1020		5.42E-05	4.98E-05	4.06E-05	2.10E-05
1050		6.89E-05	4.70E-05	2.97E-05	2.11E-05
1080		6.67E-05	4.41E-05	3.87E-05	1.81E-05
1110		7.00E-05	4.31E-05	3.69E-05	1.66E-05
1140		6.36E-05	3.81E-05	3.84E-05	1.43E-05
1170		5.94E-05	3.60E-05	3.77E-05	1.49E-05
1200		5.53E-05	3.67E-05	3.31E-05	1.10E-05
1230		5.64E-05	3.96E-05	3.23E-05	7.69E-06
1260		5.58E-05	3.21E-05	2.71E-05	9.55E-06
1290		6.09E-05	2.83E-05	2.43E-05	9.15E-06
1320		4.57E-05	3.13E-05	2.23E-05	9.00E-06
1350		4.45E-05	3.80E-05	2.22E-05	9.38E-06
1380		4.28E-05	3.88E-05	2.25E-05	9.02E-06
1410		5.06E-05	3.84E-05	2.18E-05	8.13E-06
1440		4.31E-05	3.25E-05	2.08E-05	7.60E-06
1470		4.86E-05	2.11E-05	2.51E-05	7.30E-06
1500		5.13E-05	1.56E-05	2.45E-05	7.64E-06

FLIGHT NO. C-401
TOTAL VOLUME SCATTERING COEFFICIENT

(JOB 4332 DATE 06/24/77)
 DATE 120576 FLIGHT NO. C-401 GROUND LEVEL ALTITUDE (M)= 46

ALTITUDE (M)	FILTERS	TOTAL VOLUME SCATTERING COEFFICIENT (PER M)			
		2	4	3	5
1530	4.23E-05	1.92E-05	1.92E-05	7.66E-06	
1560	3.90E-05	2.01E-05	1.06E-05	7.68E-06	
1590	3.69E-05	1.98E-05	8.18E-06	7.04E-06	
1620	4.57E-05	2.08E-05	9.97E-06	8.90E-06	
1650	4.88E-05	2.03E-05	1.07E-05	6.80E-06	
1680	4.64E-05	2.02E-05	1.11E-05	8.46E-06	
1710	4.45E-05	2.01E-05	8.50E-06	6.59E-06	
1740	4.26E-05	2.09E-05	1.03E-05	6.36E-06	
1770	4.05E-05	2.10E-05	1.05E-05	7.47E-06	
1800	4.27E-05	2.12E-05	8.05E-06	7.29E-06	
1830	3.85E-05	2.02E-05	1.05E-05	6.92E-06	
1860	4.33E-05	2.05E-05	1.15E-05	6.90E-06	
1890	4.07E-05	1.77E-05	8.95E-06	7.90E-06	
1920	3.34E-05	1.95E-05	1.14E-05	6.89E-06	
1950	4.09E-05	2.00E-05	1.07E-05	6.41E-06	
1980	3.50E-05	2.00E-05	1.03E-05	6.93E-06	
2010	3.79E-05	2.02E-05	9.11E-06	7.31E-06	
2040	3.74E-05	2.10E-05	9.56E-06	6.31E-06	
2070	3.51E-05	1.85E-05	8.27E-06	7.44E-06	
2100	3.11E-05	2.03E-05	8.74E-06	6.86E-06	
2130	3.28E-05	1.71E-05	9.55E-06	6.98E-06	
2160	3.75E-05	1.89E-05	9.20E-06	7.10E-06	
2190	3.90E-05	1.81E-05	9.20E-06	4.79E-06	
2220	3.10E-05	1.74E-05	8.99E-06	7.01E-06	
2250	4.18E-05	1.72E-05	9.09E-06	7.14E-06	
2280	3.64E-05	1.78E-05	1.03E-05	8.26E-06	
2310	3.11E-05	1.75E-05	8.28E-06	8.26E-06	
2340	3.93E-05	1.73E-05	9.57E-06	8.48E-06	
2370	3.95E-05	1.71E-05	9.22E-06	7.15E-06	
2400	3.31E-05	1.76E-05	1.00E-05	9.71E-06	
2430	3.99E-05	1.81E-05	8.03E-06	1.01E-05	
2460	3.92E-05	1.75E-05	1.02E-05	1.04E-05	
2490	3.22E-05	1.67E-05	8.89E-06	1.07E-05	
2520	3.87E-05	1.69E-05	9.56E-06	6.75E-06	
2550	3.74E-05	1.67E-05	7.52E-06	6.95E-06	
2580	3.72E-05	1.86E-05	1.01E-05	6.91E-06	
2610	3.17E-05	1.63E-05	9.06E-06	7.29E-06	
2640	3.76E-05	1.68E-05	8.86E-06	8.59E-06	
2670	3.37E-05	1.64E-05	9.31E-06	7.42E-06	
2700	3.78E-05	1.68E-05	8.84E-06	8.05E-06	
2730	3.18E-05	1.70E-05	9.42E-06	6.67E-06	
2760	3.77E-05	1.71E-05	8.43E-06	5.40E-06	
2790	3.62E-05	1.72E-05	8.00E-06	6.96E-06	
2820	3.51E-05	1.72E-05	9.13E-06	8.52E-06	
2850	3.32E-05	1.56E-05	8.46E-06	8.03E-06	
2880	3.71E-05	1.75E-05	8.22E-06	5.83E-06	
2910	3.49E-05	1.70E-05	8.35E-06	6.92E-06	
2940	3.27E-05	1.74E-05	8.48E-06	5.78E-06	
2970	3.76E-05	1.73E-05	8.86E-06	6.23E-06	
3000	3.10E-05	1.71E-05	9.66E-06	5.40E-06	

FLIGHT NO. C-401
TOTAL VOLUME SCATTERING COEFFICIENT

(JOB 4332 DATE 06/24/77)
 DATE 120576 FLIGHT NO. C-401 GROUND LEVEL ALTITUDE (M)= 46

ALTITUDE (M)	TOTAL VOLUME SCATTERING COEFFICIENT (PER M) FILTERS				
		2	4	3	5
3030	3.91E-05	1.74E-05	7.10E-06	4.42E-06	
3060	3.44E-05	1.69E-05	1.02E-05	7.42E-06	
3090	3.82E-05	1.75E-05	1.06E-05	7.79E-06	
3120	3.65E-05	1.84E-05	9.87E-06	6.68E-06	
3150	3.17E-05	1.87E-05	9.71E-06	5.97E-06	
3180	3.44E-05	1.78E-05	1.00E-05	4.33E-06	
3210	3.38E-05	1.76E-05	9.82E-06	4.43E-06	
3240	3.86E-05	1.81E-05	1.07E-05	5.83E-06	
3270	3.89E-05	1.84E-05	1.06E-05	7.52E-06	
3300	3.40E-05	1.73E-05	9.24E-06	7.44E-06	
3330	3.86E-05	1.82E-05	8.46E-06	7.36E-06	
3360	3.37E-05	1.71E-05	9.89E-06	4.04E-06	
3390	3.82E-05	1.58E-05	1.02E-05	7.10E-06	
3420	3.34E-05	1.78E-05	1.07E-05	7.43E-06	
3450	3.50E-05	1.64E-05	8.51E-06	6.23E-06	
3480	3.94E-05	1.69E-05	8.73E-06	5.03E-06	
3510	2.96E-05	1.67E-05	9.56E-06	4.13E-06	
3540	3.35E-05	1.57E-05	9.43E-06	4.32E-06	
3570	4.01E-05	1.56E-05	1.01E-05	4.57E-06	
3600	3.62E-05	1.59E-05	9.59E-06	3.66E-06	
3630	3.58E-05	1.77E-05	9.72E-06	5.64E-06	
3660	3.54E-05	1.55E-05	9.86E-06	3.78E-06	
3690	3.71E-05	1.53E-05	9.66E-06	4.05E-06	
3720	3.88E-05	1.54E-05	1.02E-05	3.84E-06	
3750	3.89E-05	1.58E-05	1.02E-05	2.95E-06	
3780	3.91E-05	1.49E-05	1.02E-05	3.94E-06	
3810	3.92E-05	1.73E-05	1.02E-05	4.94E-06	
3840	3.77E-05	1.52E-05	9.64E-06	4.55E-06	
3870	3.56E-05	1.47E-05	9.61E-06	2.43E-06	
3900	3.67E-05	1.75E-05	1.10E-05	3.07E-06	
3930	3.77E-05	1.48E-05	6.63E-06	5.78E-06	
3960	3.42E-05	1.53E-05	1.01E-05	7.00E-06	
3990	3.88E-05	1.76E-05	7.84E-06	7.13E-06	
4020	3.87E-05	1.47E-05	7.09E-06	6.90E-06	
4050	3.41E-05	1.52E-05	7.90E-06	6.67E-06	
4080	3.43E-05	1.29E-05	1.10E-05	4.31E-06	
4110	3.49E-05	1.51E-05	9.76E-06	6.13E-06	
4140	3.52E-05	1.40E-05	7.61E-06	6.41E-06	
4170	3.61E-05	1.43E-05	8.54E-06	6.64E-06	
4200	3.45E-05	1.53E-05	8.42E-06	6.29E-06	
4230	2.85E-05	1.43E-05	8.07E-06	7.44E-06	
4260	3.38E-05	1.47E-05	8.30E-06	5.17E-06	
4290	3.31E-05	1.45E-05	5.98E-06	7.11E-06	
4320	2.77E-05	1.26E-05	8.01E-06	6.36E-06	
4350	2.87E-05	1.46E-05	8.07E-06	5.80E-06	
4380	2.97E-05	1.56E-05	8.12E-06	5.23E-06	
4410	3.43E-05	1.47E-05	8.44E-06	6.78E-06	
4440	3.13E-05	1.56E-05	9.11E-06	5.30E-06	
4470	3.19E-05	1.53E-05	8.30E-06	5.44E-06	
4500	2.79E-05	1.50E-05	7.52E-06	5.57E-06	

FLIGHT NO. C-401
TOTAL VOLUME SCATTERING COEFFICIENT

(JOB 4332 DATE 06/24/77)
 DATE 120576 FLIGHT NO. C-401 GROUND LEVEL ALTITUDE (M)= 46

ALTITUDE (M)	TOTAL VOLUME SCATTERING COEFFICIENT (PER M)				
	FILTERS	2	4	3	5
4530		3.36E-05	1.50E-05	7.52E-06	5.45E-06
4560		3.27E-05	1.46E-05	8.13E-06	5.49E-06
4590		3.06E-05	1.49E-05	8.26E-06	6.10E-06
4620		3.32E-05	1.27E-05	7.87E-06	6.14E-06
4650		3.31E-05	1.44E-05	7.74E-06	6.18E-06
4680		3.06E-05	1.39E-05	9.09E-06	5.44E-06
4710		3.23E-05	1.40E-05	6.76E-06	6.97E-06
4740		2.73E-05	1.37E-05	8.74E-06	7.47E-06
4770		3.16E-05	1.38E-05	5.32E-06	6.14E-06
4800		2.85E-05	1.35E-05	7.97E-06	5.62E-06
4830		3.13E-05	1.31E-05	7.04E-06	5.92E-06
4860		2.86E-05	1.35E-05	8.33E-06	6.40E-06
4890		2.41E-05	1.30E-05	7.39E-06	6.61E-06
4920		2.89E-05	1.32E-05	7.21E-06	6.08E-06
4950		3.23E-05	1.33E-05	8.67E-06	7.51E-06
4980		3.18E-05	1.28E-05	7.54E-06	6.37E-06
5010		3.13E-05	1.29E-05	6.60E-06	7.40E-06
5040		2.85E-05	1.31E-05	7.37E-06	5.72E-06
5070		2.97E-05	1.22E-05	8.54E-06	5.03E-06
5100		2.82E-05	1.27E-05	7.17E-06	5.15E-06
5130		2.66E-05	1.32E-05	8.33E-06	5.15E-06
5160		2.50E-05	1.30E-05	7.10E-06	7.54E-06
5190		2.48E-05	1.28E-05	7.82E-06	(7.51E-06)
5220		(2.48E-05)	(1.28E-05)	(7.80E-06)	(7.49E-06)
5250		(2.47E-05)	(1.27E-05)	(7.77E-06)	(7.47E-06)
5280		(2.46E-05)	(1.27E-05)	(7.75E-06)	(7.44E-06)
5310		(2.45E-05)	(1.26E-05)	(7.73E-06)	(7.42E-06)
5340		(2.45E-05)	(1.26E-05)	(7.70E-06)	(7.40E-06)
5370		(2.44E-05)	(1.26E-05)	(7.68E-06)	(7.37E-06)
5400		(2.43E-05)	(1.25E-05)	(7.65E-06)	(7.35E-06)
FIRST DATA ALT		450	420	390	420
LAST DATA ALT		5190	5190	5190	5160

FLIGHT NO. C-401
EQUIVALENT ATTENUATION LENGTH

(JOB 4332 DATE 06/24/77)
DATE 120576 FLIGHT NO. C-401 GROUND LEVEL ALTITUDE (M)= 46

ALTITUDE (M)	EQUIVALENT ATTENUATION LENGTH (M)			
	FILTERS 2	4	3	5
0	1.24E 04	1.17E 04	2.72E 04	2.83E 04
300	1.26E 04	1.19E 04	2.76E 04	2.87E 04
600	1.26E 04	1.24E 04	2.69E 04	2.81E 04
900	1.31E 04	1.31E 04	2.47E 04	2.80E 04
1200	1.36E 04	1.45E 04	2.45E 04	3.15E 04
1500	1.46E 04	1.62E 04	2.66E 04	3.69E 04
1800	1.55E 04	1.83E 04	3.01E 04	4.20E 04
2100	1.65E 04	2.01E 04	3.35E 04	4.67E 04
2400	1.74E 04	2.19E 04	3.66E 04	5.08E 04
2700	1.81E 04	2.35E 04	3.96E 04	5.43E 04
3000	1.88E 04	2.50E 04	4.24E 04	5.80E 04
3300	1.94E 04	2.63E 04	4.47E 04	6.16E 04
3600	1.99E 04	2.76E 04	4.70E 04	6.52E 04
3900	2.03E 04	2.89E 04	4.90E 04	6.91E 04
4200	2.07E 04	3.01E 04	5.11E 04	7.21E 04
4500	2.12E 04	3.13E 04	5.32E 04	7.49E 04
4800	2.16E 04	3.24E 04	5.52E 04	7.75E 04
5100	2.21E 04	3.35E 04	5.72E 04	8.00E 04
5400	2.27E 04	3.46E 04	5.90E 04	8.19E 04

FLIGHT NO. C-401
VERTICAL BEAM TRANSMITTANCE FROM GROUND TO ALTITUDE

ALTITUDE (M)	VERTICAL BEAM TRANSMITTANCE FROM GROUND TO ALTITUDE			
	FILTERS 2	4	3	5
0	1.00E 00	1.00E 00	1.00E 00	1.00E 00
300	9.76E-01	9.75E-01	9.89E-01	9.90E-01
600	9.54E-01	9.53E-01	9.78E-01	9.79E-01
900	9.34E-01	9.34E-01	9.64E-01	9.68E-01
1200	9.16E-01	9.21E-01	9.52E-01	9.63E-01
1500	9.02E-01	9.12E-01	9.45E-01	9.60E-01
1800	8.90E-01	9.06E-01	9.42E-01	9.58E-01
2100	8.80E-01	9.01E-01	9.39E-01	9.56E-01
2400	8.71E-01	8.96E-01	9.37E-01	9.54E-01
2700	8.61E-01	8.91E-01	9.34E-01	9.51E-01
3000	8.52E-01	8.87E-01	9.32E-01	9.50E-01
3300	8.43E-01	8.82E-01	9.29E-01	9.48E-01
3600	8.34E-01	8.78E-01	9.26E-01	9.46E-01
3900	8.25E-01	8.74E-01	9.23E-01	9.45E-01
4200	8.16E-01	8.70E-01	9.21E-01	9.43E-01
4500	8.09E-01	8.66E-01	9.19E-01	9.42E-01
4800	8.01E-01	8.62E-01	9.17E-01	9.40E-01
5100	7.94E-01	8.59E-01	9.15E-01	9.38E-01
5400	7.88E-01	8.56E-01	9.13E-01	9.36E-01

FLIGHT C-402 – 6 DECEMBER 1976 – DESCRIPTION OF FLIGHT AND WEATHER CHARACTERISTICS

Filter Ident	Data Interval			Solar Zenith Angle			Flight Altitude (meters)		Average Terrain Elevation (meters)
	Start (GMT)	End (GMT)	Elapsed (hrs) (min)	Initial (degrees)	Solar Transit (degrees)	Final (degrees)	(min)	(max)	
2,3	1201	1318	1 17	70.6	–	72.9	390	3900	46
4,5	1324	1445	1 21	73.2	–	79.9	420	3840	46

Flight C-402 was an afternoon flight beginning shortly after noon. There were scattered cumulus clouds and scattered to broken cirrus with at times no clear sky.

The approximate east to west Bruz track was centered south of Rennes in northwestern France. Typical terrain features were green fields interspersed with some brown areas and dark green trees.

The in-flight observer noted that there were lots of weather variations. Scattered cumulus clouds had bases 1050 to 1500 meters (3500 to 5000 feet), scattered altostratus at 2400 to 4500 meters (8000 to 15 000 feet), scattered to broken cirrus at 6000 meters (20 000 feet) were present with moderate haze. It was noted that the haze was surprisingly heavy for post frontal conditions.

At Rennes/St. Jacques, north of the center of the track, there were 3/8 cumulonimbus at 600 meters (2000 feet), 4/8 to 6/8 altocumulus at 4500 meters (15 000 feet), 5/8 to 7/8 thin cirrus at 6000 to 6600 meters (20 000 to 22 000 feet). Visibility was 11.2 to 18 kilometers.

St. Nazaire-Montoir, south of the track, reported 5/8 cumulonimbus at 600 meters (2000 feet) becoming cumulus and stratocumulus at 690 to 750 meters (2300 to 2500 feet), 6/8 altostratus at 4500 meters (15 000 feet), 7/8 cirrus at 6000 to 6600 meters (20 000 to 22 000 feet). Visibility was 11.2 to 20 kilometers.

Nantes-Chateau Bougon, south of the track center, reported 2/8 to 3/8 cumulus and stratocumulus at 750 to 1050 meters (2500 to 3500 feet), 3/8 to 5/8 altocumulus at 2700 to 4500 meters (9000 to 15 000 feet), 6/8 to 7/8 thin cirrus at 7500 meters (25 000 feet). Visibility was 11.2 to 20 kilometers.

Anbers/Avrille, southeast of the track, reported 3/8 to 4/8 cumulus and cumulonimbus at 750 meters (2500 feet), 4/8 to 6/8 altocumulus at 4500 meters (15 000 feet), 5/8 thin cirrus at 7500 meters (25 000 feet). Visibility was 10 to 20 kilometers.

The radiosonde station at Brest was approximately 200 kilometers westnorthwest of the center of the flight track. The radiosonde station was upstream from the track.

The surface chart for 1200 GMT had an extensive storm with a 956-millibar low at 56N 12W and a 970-millibar low at 52N 31W. An occlusion that had passed through France was now along a line through the North Sea-Luxemburg-Bordeaux then as a cold front into the Atlantic. At 500 millibars there was a low off northern Ireland associated with the surface low that produced a strong westsouthwesterly gradient and winds over western Europe. The airmass was unstable maritime polar.

FLIGHT NO. C-402

BRUZ

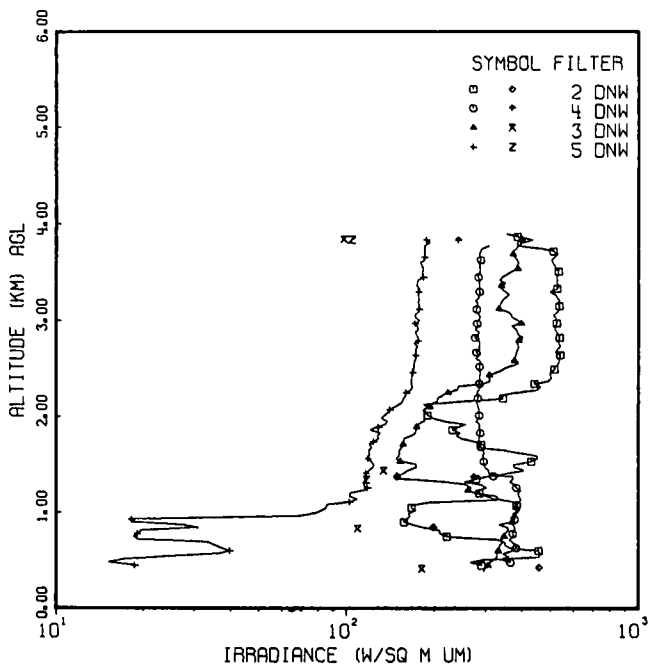
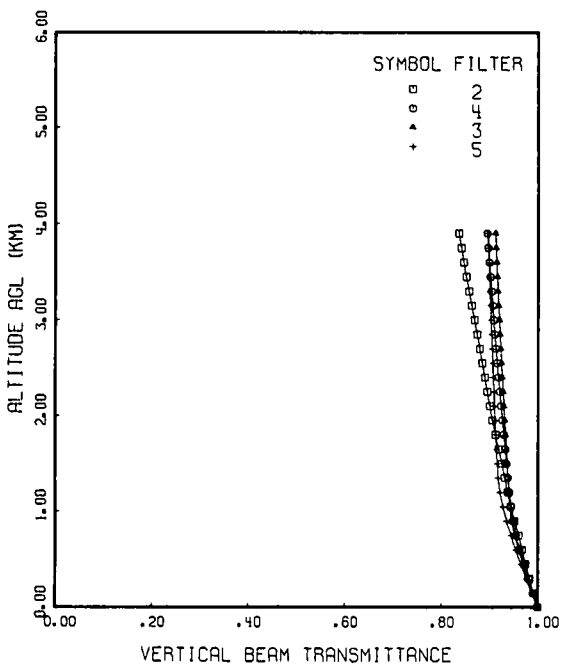
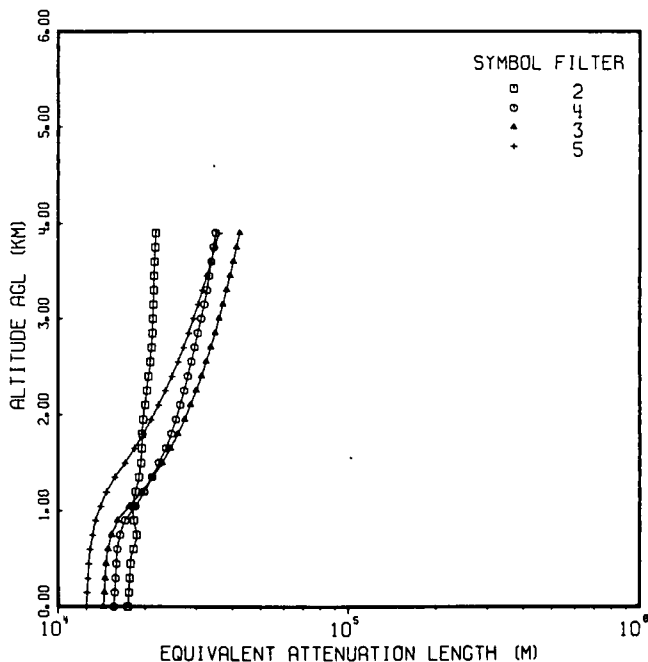
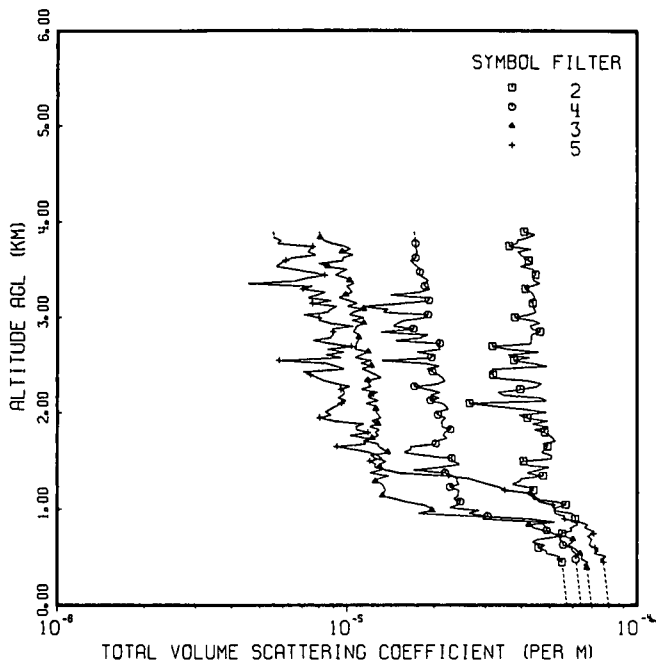

FLIGHT NO. C-402
TOTAL VOLUME SCATTERING COEFFICIENT

(JOB 4397 DATE 09/26/77)
 DATE 120676 FLIGHT NO. C-402 GROUND LEVEL ALTITUDE (M)= 46

ALTITUDE (M)	TOTAL VOLUME SCATTERING COEFFICIENT (PER M)			
	FILTERS	2	4	3
0	(5.74E-05)	(6.42E-05)	(6.97E-05)	(7.99E-05)
30	(5.71E-05)	(6.39E-05)	(6.93E-05)	(7.95E-05)
60	(5.70E-05)	(6.37E-05)	(6.92E-05)	(7.93E-05)
90	(5.68E-05)	(6.36E-05)	(6.90E-05)	(7.91E-05)
120	(5.67E-05)	(6.34E-05)	(6.88E-05)	(7.89E-05)
150	(5.65E-05)	(6.33E-05)	(6.86E-05)	(7.87E-05)
180	(5.64E-05)	(6.31E-05)	(6.85E-05)	(7.85E-05)
210	(5.62E-05)	(6.29E-05)	(6.83E-05)	(7.83E-05)
240	(5.61E-05)	(6.28E-05)	(6.81E-05)	(7.81E-05)
270	(5.59E-05)	(6.26E-05)	(6.79E-05)	(7.79E-05)
300	(5.58E-05)	(6.24E-05)	(6.78E-05)	(7.77E-05)
330	(5.57E-05)	(6.23E-05)	(6.76E-05)	(7.75E-05)
360	(5.55E-05)	(6.21E-05)	(6.74E-05)	(7.73E-05)
390	(5.54E-05)	(6.19E-05)	6.72E-05	(7.71E-05)
420	(5.52E-05)	(6.18E-05)	6.56E-05	(7.69E-05)
450	5.51E-05	(6.16E-05)	6.79E-05	7.67E-05
480	5.30E-05	6.14E-05	6.44E-05	7.47E-05
510	5.42E-05	6.23E-05	6.45E-05	7.86E-05
540	4.88E-05	6.14E-05	6.37E-05	7.10E-05
570	4.87E-05	5.97E-05	6.22E-05	7.38E-05
600	4.57E-05	5.94E-05	6.03E-05	7.16E-05
630	4.82E-05	5.56E-05	5.80E-05	6.85E-05
660	4.35E-05	5.58E-05	5.97E-05	6.92E-05
690	4.57E-05	5.40E-05	6.02E-05	7.00E-05
720	5.30E-05	5.47E-05	5.64E-05	6.75E-05
750	5.52E-05	5.12E-05	5.14E-05	7.08E-05
780	5.97E-05	4.88E-05	4.79E-05	6.98E-05
810	5.89E-05	4.89E-05	4.39E-05	6.59E-05
840	6.23E-05	4.75E-05	4.24E-05	6.77E-05
870	6.14E-05	4.72E-05	5.19E-05	6.30E-05
900	6.12E-05	2.93E-05	4.32E-05	5.63E-05
930	6.13E-05	3.05E-05	2.75E-05	5.58E-05
960	5.95E-05	2.63E-05	1.76E-05	5.21E-05
990	5.16E-05	2.84E-05	1.97E-05	5.23E-05
1020	5.28E-05	2.26E-05	1.93E-05	5.17E-05
1050	5.68E-05	2.42E-05	1.83E-05	5.12E-05
1080	5.26E-05	2.46E-05	1.59E-05	4.59E-05
1110	4.40E-05	2.33E-05	1.46E-05	4.57E-05
1140	4.34E-05	2.41E-05	1.32E-05	4.41E-05
1170	4.14E-05	2.42E-05	1.34E-05	4.34E-05
1200	4.39E-05	2.43E-05	1.36E-05	3.49E-05
1230	4.25E-05	2.26E-05	1.34E-05	3.36E-05
1260	3.71E-05	2.43E-05	1.32E-05	3.06E-05
1290	3.94E-05	2.39E-05	1.25E-05	2.82E-05
1320	4.01E-05	2.39E-05	1.28E-05	2.61E-05
1350	4.74E-05	2.30E-05	1.39E-05	2.23E-05
1380	4.17E-05	2.18E-05	1.20E-05	1.50E-05
1410	4.56E-05	1.70E-05	1.31E-05	1.35E-05
1440	4.95E-05	2.10E-05	1.30E-05	1.25E-05
1470	3.95E-05	2.44E-05	1.30E-05	1.25E-05
1500	4.05E-05	2.31E-05	1.37E-05	1.20E-05

FLIGHT NO. C-402
TOTAL VOLUME SCATTERING COEFFICIENT

(JOB 4397 DATE 09/26/77)
 DATE 120676 FLIGHT NO. C-402 GROUND LEVEL ALTITUDE (M)= 46

ALTITUDE (M)	TOTAL FILTERS	TOTAL VOLUME SCATTERING COEFFICIENT (PER M)			
		2	4	3	5
1530	5.06E-05	2.29E-05	1.24E-05	1.32E-05	
1560	5.06E-05	1.85E-05	1.21E-05	1.27E-05	
1590	4.70E-05	1.57E-05	1.38E-05	1.19E-05	
1620	4.81E-05	1.66E-05	1.33E-05	1.06E-05	
1650	4.91E-05	1.65E-05	1.28E-05	9.21E-06	
1680	4.74E-05	2.02E-05	1.28E-05	1.16E-05	
1710	5.23E-05	2.02E-05	1.15E-05	1.14E-05	
1740	5.10E-05	2.21E-05	1.22E-05	1.20E-05	
1770	4.97E-05	2.15E-05	1.28E-05	1.02E-05	
1800	4.79E-05	2.17E-05	1.25E-05	1.18E-05	
1830	4.42E-05	2.27E-05	1.29E-05	1.08E-05	
1860	4.94E-05	2.12E-05	1.20E-05	1.07E-05	
1890	4.35E-05	2.12E-05	1.28E-05	1.14E-05	
1920	4.91E-05	2.12E-05	1.22E-05	8.99E-06	
1950	4.18E-05	2.19E-05	1.31E-05	8.03E-06	
1980	3.92E-05	2.06E-05	1.28E-05	8.81E-06	
2010	4.86E-05	2.03E-05	1.26E-05	8.39E-06	
2040	4.07E-05	2.24E-05	1.26E-05	8.78E-06	
2070	3.27E-05	2.19E-05	1.26E-05	9.16E-06	
2100	2.64E-05	2.13E-05	1.16E-05	9.54E-06	
2130	4.88E-05	1.94E-05	1.28E-05	9.92E-06	
2160	4.60E-05	2.07E-05	1.19E-05	9.29E-06	
2190	3.45E-05	1.94E-05	1.21E-05	9.70E-06	
2220	3.31E-05	2.09E-05	1.27E-05	9.80E-06	
2250	3.95E-05	1.90E-05	1.12E-05	9.50E-06	
2280	4.52E-05	1.71E-05	1.21E-05	1.02E-05	
2310	4.69E-05	2.07E-05	1.18E-05	9.10E-06	
2340	4.18E-05	2.18E-05	1.18E-05	8.26E-06	
2370	3.22E-05	2.12E-05	1.31E-05	7.86E-06	
2400	3.18E-05	2.06E-05	1.25E-05	7.46E-06	
2430	3.11E-05	1.97E-05	1.19E-05	7.06E-06	
2460	3.18E-05	1.88E-05	1.12E-05	9.77E-06	
2490	4.88E-05	2.07E-05	1.21E-05	9.09E-06	
2520	4.33E-05	1.85E-05	1.11E-05	8.41E-06	
2550	3.75E-05	1.32E-05	1.21E-05	5.80E-06	
2580	4.26E-05	1.95E-05	1.06E-05	9.53E-06	
2610	3.59E-05	2.01E-05	1.12E-05	8.47E-06	
2640	4.57E-05	1.75E-05	1.18E-05	9.74E-06	
2670	3.60E-05	2.09E-05	1.07E-05	8.58E-06	
2700	3.17E-05	2.06E-05	1.07E-05	1.03E-05	
2730	4.30E-05	2.09E-05	1.07E-05	8.72E-06	
2760	4.31E-05	1.47E-05	1.09E-05	7.60E-06	
2790	4.32E-05	1.80E-05	1.10E-05	8.78E-06	
2820	4.34E-05	1.90E-05	1.10E-05	8.94E-06	
2850	4.62E-05	1.31E-05	1.05E-05	8.93E-06	
2880	4.34E-05	1.69E-05	1.07E-05	8.91E-06	
2910	4.27E-05	1.44E-05	1.08E-05	1.05E-05	
2940	4.60E-05	1.50E-05	1.14E-05	8.72E-06	
2970	4.34E-05	1.56E-05	1.04E-05	8.07E-06	
3000	3.78E-05	1.84E-05	1.14E-05	7.99E-06	

FLIGHT NO. C-402
TOTAL VOLUME SCATTERING COEFFICIENT

{JOB 4397 DATE 09/26/77}
 DATE 120676 FLIGHT NO. C-402 GROUND LEVEL ALTITUDE (M)= 46

ALTITUDE (M)	FILTERS	TOTAL VOLUME SCATTERING COEFFICIENT (PER M)			
		2	4	3	5
3030	4.24E-05	1.90E-05	1.02E-05	7.11E-06	
3060	4.48E-05	1.33E-05	1.05E-05	8.60E-06	
3090	4.41E-05	1.38E-05	1.14E-05	8.80E-06	
3120	4.38E-05	1.14E-05	1.00E-05	9.21E-06	
3150	4.36E-05	1.52E-05	1.08E-05	7.59E-06	
3180	4.29E-05	1.91E-05	1.01E-05	8.80E-06	
3210	4.44E-05	1.89E-05	9.37E-06	7.33E-06	
3240	4.37E-05	1.41E-05	9.89E-06	7.88E-06	
3270	4.30E-05	1.78E-05	1.04E-05	8.42E-06	
3300	4.10E-05	1.93E-05	1.02E-05	7.03E-06	
3330	4.32E-05	1.85E-05	9.93E-06	7.57E-06	
3360	4.61E-05	1.84E-05	1.05E-05	4.54E-06	
3390	4.38E-05	1.91E-05	1.02E-05	6.70E-06	
3420	4.38E-05	1.84E-05	9.87E-06	7.31E-06	
3450	4.46E-05	1.77E-05	9.09E-06	8.35E-06	
3480	4.41E-05	1.78E-05	9.52E-06	7.46E-06	
3510	4.37E-05	1.79E-05	9.95E-06	6.57E-06	
3540	3.96E-05	1.74E-05	8.54E-06	5.68E-06	
3570	4.36E-05	1.69E-05	7.99E-06	5.90E-06	
3600	4.21E-05	1.65E-05	9.63E-06	6.12E-06	
3630	4.06E-05	1.72E-05	9.68E-06	6.48E-06	
3660	3.97E-05	1.73E-05	1.05E-05	7.78E-06	
3690	3.87E-05	1.74E-05	9.58E-06	7.33E-06	
3720	4.30E-05	1.73E-05	1.03E-05	7.47E-06	
3750	3.61E-05	1.72E-05	9.80E-06	7.60E-06	
3780	3.85E-05	1.72E-05	8.86E-06	5.75E-06	
3810	3.86E-05	(1.71E-05)	8.31E-06	5.92E-06	
3840	4.20E-05	(1.71E-05)	8.04E-06	5.57E-06	
3870	4.44E-05	(1.70E-05)	(8.02E-06)	(5.56E-06)	
3900	4.07E-05	(1.70E-05)	(7.99E-06)	(5.54E-06)	
FIRST DATA ALT	450	480	390	450	
LAST DATA ALT	3900	3780	3840	3840	

FLIGHT NO. C-402
EQUIVALENT ATTENUATION LENGTH

(JOB 4397 DATE 09/26/77)
 DATE 120676 FLIGHT NO. C-402 GROUND LEVEL ALTITUDE (M)= 46

ALTITUDE (M)	EQUIVALENT ATTENUATION LENGTH (M)			
	FILTERS 2	4	3	5
0	1.74E 04	1.56E 04	1.44E 04	1.25E 04
300	1.77E 04	1.58E 04	1.46E 04	1.27E 04
600	1.82E 04	1.60E 04	1.49E 04	1.29E 04
900	1.83E 04	1.71E 04	1.61E 04	1.35E 04
1200	1.86E 04	1.99E 04	1.95E 04	1.48E 04
1500	1.94E 04	2.24E 04	2.29E 04	1.71E 04
1800	1.95E 04	2.47E 04	2.60E 04	1.97E 04
2100	2.00E 04	2.64E 04	2.87E 04	2.23E 04
2400	2.05E 04	2.81E 04	3.13E 04	2.48E 04
2700	2.10E 04	2.96E 04	3.37E 04	2.71E 04
3000	2.12E 04	3.12E 04	3.60E 04	2.94E 04
3300	2.14E 04	3.27E 04	3.82E 04	3.16E 04
3600	2.15E 04	3.38E 04	4.03E 04	3.38E 04
3900	2.18E 04	3.50E 04	4.23E 04	3.59E 04

FLIGHT NO. C-402
VERTICAL BEAM TRANSMITTANCE FROM GROUND TO ALTITUDE

ALTITUDE (M)	VERTICAL BEAM TRANSMITTANCE FROM GROUND TO ALTITUDE			
	FILTERS 2	4	3	5
0	1.00E 00	1.00E 00	1.00E 00	1.00E 00
300	9.83E-01	9.81E-01	9.80E-01	9.77E-01
600	9.68E-01	9.63E-01	9.61E-01	9.55E-01
900	9.52E-01	9.49E-01	9.46E-01	9.36E-01
1200	9.37E-01	9.41E-01	9.40E-01	9.22E-01
1500	9.26E-01	9.35E-01	9.37E-01	9.16E-01
1800	9.12E-01	9.30E-01	9.33E-01	9.13E-01
2100	9.00E-01	9.24E-01	9.30E-01	9.10E-01
2400	8.90E-01	9.18E-01	9.26E-01	9.08E-01
2700	8.80E-01	9.13E-01	9.23E-01	9.05E-01
3000	8.68E-01	9.08E-01	9.20E-01	9.03E-01
3300	8.57E-01	9.04E-01	9.17E-01	9.01E-01
3600	8.46E-01	8.99E-01	9.15E-01	8.99E-01
3900	8.36E-01	8.94E-01	9.12E-01	8.97E-01

8. DATA INTERPRETATION AND EVALUATION

8.1 METEOROLOGICAL DATA

The basic discussion of meteorological conditions, as presented in Section 6 and summarized with each flight description, is based upon meteorological data from a number of sources. There are hourly observations from two or more weather stations for every flight. There are in-flight observations by an on-board meteorologist for all but one flight. In addition, there are in-flight hemispherical pictures of the sky.

CLOUD CONDITIONS

The airborne pictures which documented the cloud conditions and the observations by an on-board meteorologist during each flight were described in Table 7.2. Their general features are summarized in Table 8.1. The upper sky descriptions are divided into three categories, and the lower sky descriptions are divided into two categories.

TEMPERATURE

The temperature measurements were made using the AN/AMQ-17 aerograph set. The graphs of temperature in Fig. 6-2 indicate reasonable agreement between the airborne temperatures and the radiosonde temperatures in view of the spatial differences between the two measurements. On all the flights the RAOB launching was 81 to 200 kilometers from the flight track. Therefore the differences between these aircraft and radiosonde measurements of temperature may be due to the temporal and spatial differences in the two bodies of air.

For most of the flights the graphs in Fig. 6-2 show a relatively stable temperature function with altitude over the flight time interval. This is indicated by the general repeatability of the temperatures during each profile time interval. The exceptions are Flight C-395 where the temperatures are more variable with time in the altitude interval 2.3 to 4 kilometers and Flight C-401 where the temperatures are more variable above 4 kilometers. The data for both flights were taken in the order: Filter 2, Filter 3, Filter 4, then Filter 5. The graphs in Fig. 6-2 indicate a monotonic change of temperature with time for the upper altitude temperatures for C-401 and the 2.3 to 3 kilometer data for Flight C-395. Between 3 and 4 kilometers altitude on C-395, however, the temperature is variable with time; it decreased, then increased, then again decreased with time.

Table 8.1

Cloud Condition Summary

Flights	Upper Hemisphere		Lower Hemisphere	
	Category	Description	Category	Description
C-401 (Filters 2 3)	1	Scattered to broken clouds low altitude, clear high altitude	1	Haze, no clouds
* C-397			2	Clouds
C-390 (Filters 2, 3)	2	Scattered to broken clouds all altitudes	1	Haze, no clouds
C-395				
C-390 (Filters 4, 5)			2	Clouds
* C-391				
C-398				
C-400				
* C-401 (Filters 4, 5)				
C-402				
C-392 (Filters 2, 3)	3	Overcast	1	Haze, no clouds
C-394				
* C-392 (Filters 4 5)			2	Clouds
C-393				
C-399				

* Pictures in Figures 7-1 and 7-2

There were 12 usable project flights, listed in Table 7 3, accomplished between 25 October and 6 December 1976 at tracks from 48.02°N to 54 68°N latitude. Temperature data measured during these flights can be profitably compared to data from U S Standard Atmosphere Supplements (1966). To facilitate this comparison, the average temperature profile measured during each of the 12 flights has been superimposed on a graph of the temperatures appropriate for 45° and 60°N latitudes in Figs 8-1 and 8-2. The anticipated fall temperature profile should lie above the 60°N latitude, January profile, and near the profiles for 45°N latitude in spring/fall and January as specified in the U S Standard Atmosphere Supplements (1966). The altitude scale in Figs 8-1 and 8-2 is kilometers above mean sea level (MSL). The ground elevations at the test sites range from 0 meters in Denmark to 46 meters in France.

The temperatures for the first two flights, C-390 and C-391, in late October are slightly above but similar to the 45°N Spring/Fall temperatures at altitudes above 1 kilometer. The temperatures for the rest of the flights are less than but somewhat parallel to the 45-degree spring/fall temperatures at all altitudes. They all seem reasonable for these latitudes for late fall.

Both flights, C-390 and C-391, have temperature inversion layers near 1 kilometer altitude. The one for C-391 is particularly pronounced.

RELATIVE HUMIDITY

Relative humidity was computed from the measured values of ambient temperature and dewpoint temperature. The dewpoint temperatures were measured using the modified Cambridge hygrometer system [Duntley, *et al.* (1972c)] and are the third set of data reported since the modification was completed.

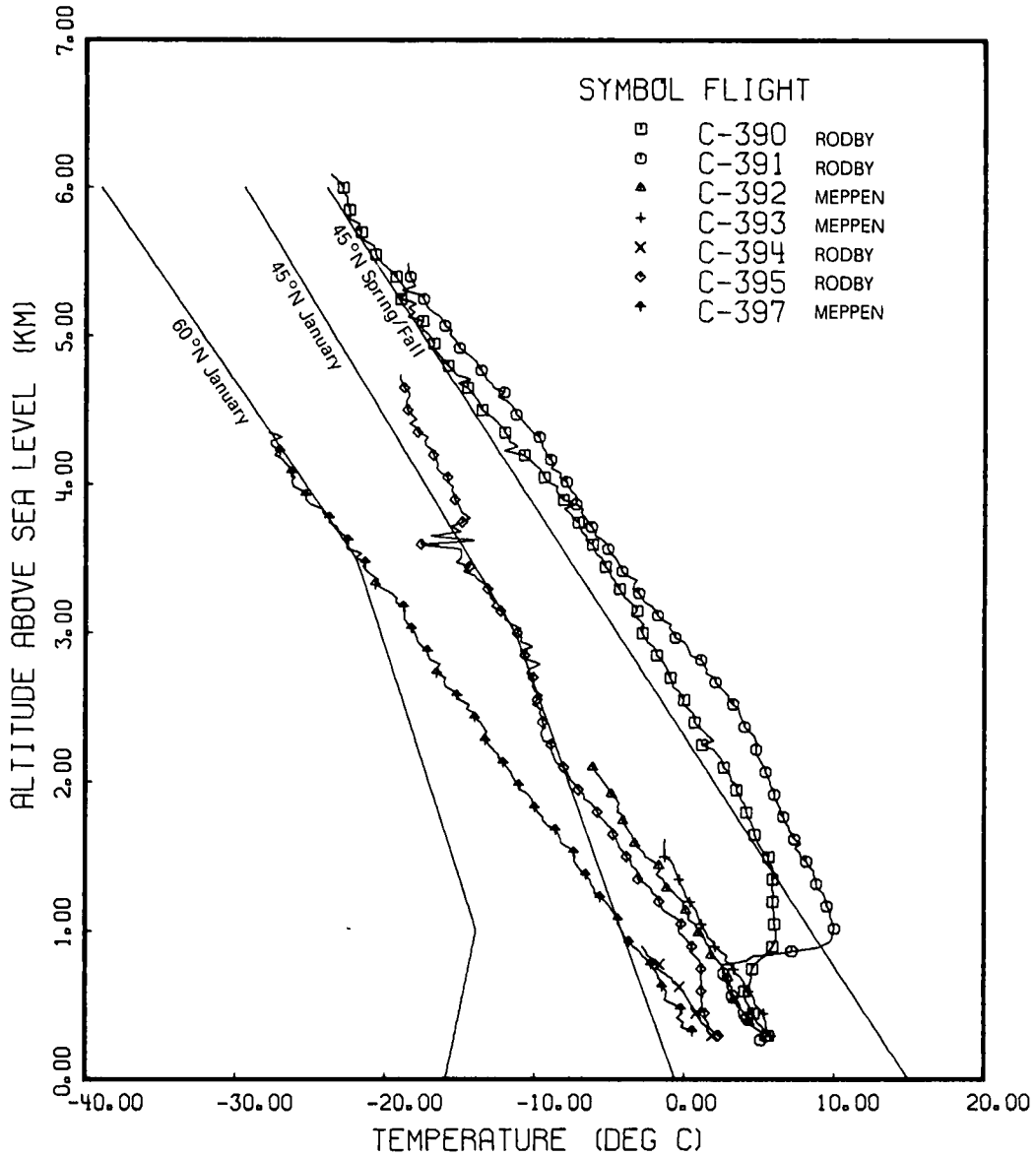

Fig. 8-1. Temperature for OPAQUE II Flights 26 October to 23 November 1976, Latitudes 53°N to 54.68°N Compared to Temperature From U.S. Standard Atmosphere Supplements (1966).

A faulty output amplifier interposed an intermittent spurious signal on the dewpoint temperature data beginning with Flight C-395. Deletions of the spurious values are particularly apparent in the relative humidity graphs for Flights C-398, C-400, and C-401 in Fig. 6-3. Long straight line interpolations between valid data points are apparent in the C-398 graph of relative humidity measured concurrently with Filter 4, in the C-400 graph during Filters 3 and 4, and in C-401 during Filter 2. The dewpoint hygrometer was not operated during Flight C-402.

No relative humidities were given in the hourly reports for the local weather stations. Therefore the only comparison that can be made is to the radiosonde data on relative humidity. Again, on all the flights, the radiosonde launching station was distant from the flight track. Therefore any differences depicted in Fig. 6-3 between these airborne and radiosonde relative humidities may be due to real differences in the two bodies of air, and not necessarily due to instrumental error.

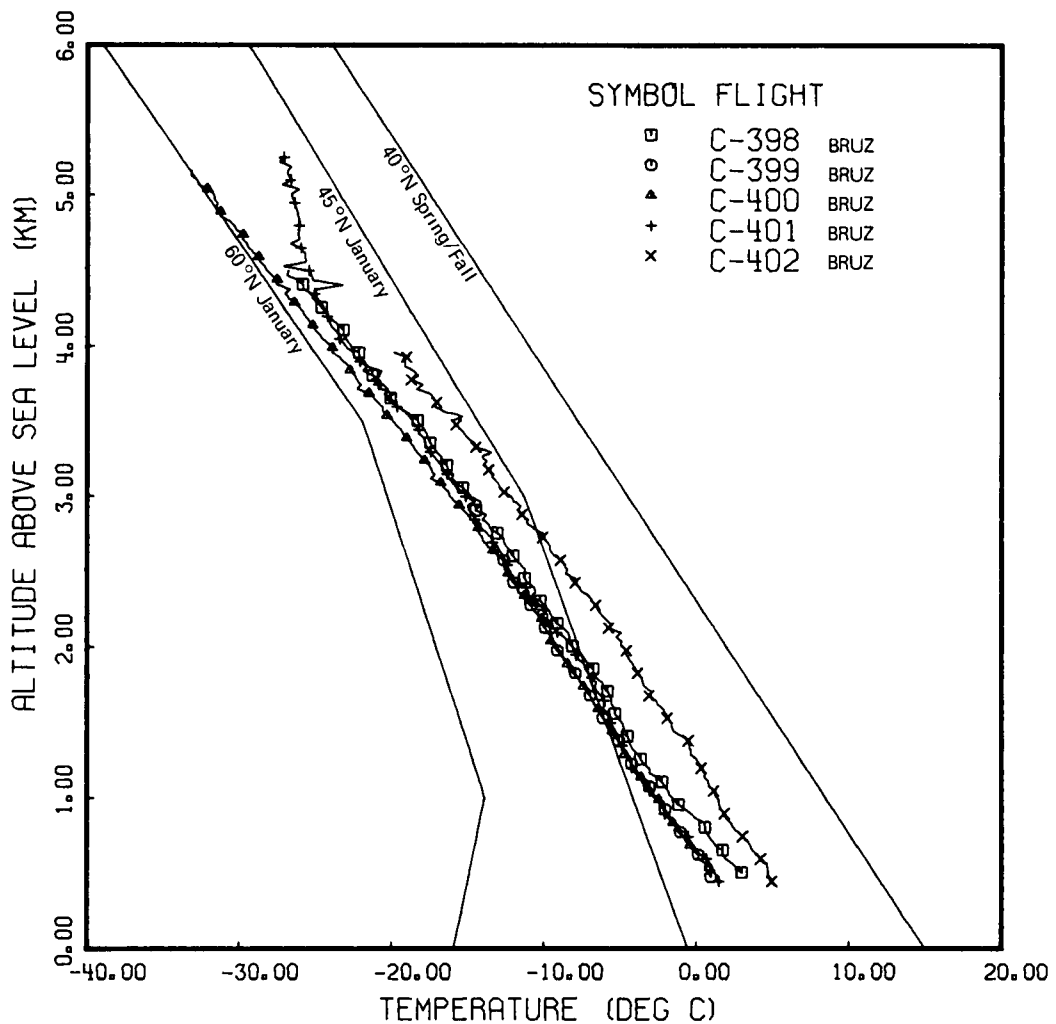

Fig. 8-2. Temperature for OPAQUE II Flights 2 to 6 December 1976, Latitude 48.02°N Compared to Temperature From U.S. Standard Atmosphere Supplements (1966).

The graphs in Fig. 6-3 indicate that relative humidity is less stable over the time interval of the flight than is temperature. The general structure with altitude is usually repeated for the four profiles, but the range of values at any one altitude is often quite large. Particularly noticeable are the wide range of relative humidity values for Flight C-390 and from 1.2 to 2.7 kilometers and Flight C-398 from 1.2 to 2.8 kilometers.

8.2 AIRBORNE RADIOMETRIC DATA

TOTAL VOLUME SCATTERING COEFFICIENT

The nephelometer was known to have stray light problems during the OPAQUE I deployment which affected both the total volume scattering coefficient measurement and the volume scattering functions measurement at 150 degrees. Prior to OPAQUE II, modifications were made to the light trap at $\beta = 150^\circ$ and a black mirror was added near the light exit port to control interior stray light. In order to determine how well these modifications reduced the stray light errors, the OPAQUE II nephelometer data were subjected to the same analysis as the OPAQUE I data, see pages 8-5 through 8-12 of Duntley, *et al.* (1977).

Evidence of Stray Light in Total Volume Scattering Coefficient Data. The graph of proportional volume scattering function at 30 and 150 degrees versus the ratio of the total to Rayleigh volume scattering coefficient s/ρ_s for the pseudo-photopic filter 4 OPAQUE II data is given in Fig. 8-3. The curves are the median values derived from Barteneva (1960). We have found that the most recent historical data from deployments between 1970 and 1976 compared reasonably well to this Barteneva curve, see Fig. 8-3 of Duntley, *et al.* (1977). The OPAQUE II proportional volume scattering function data for 150 degrees versus the total to Rayleigh volume scattering coefficient ratio is more similar to the Barteneva curve than were the OPAQUE I data, indicating that the bulk of the stray light error in the measurement of volume scattering function at 150 degrees had indeed been corrected by the modifications. The graph of proportional volume scattering function data for 30 degrees versus the total to Rayleigh ratio is, however, similar to that of the OPAQUE I data, see Fig. 8-4 of Duntley, *et al.* (1977). This indicates that the stray light error in the measurement of total volume scattering coefficient had not yet been corrected. We have since revised the design of the entrance to the primary light trap in a further attempt to eliminate the problem.

The stray light error in the total volume scattering coefficient was corrected for OPAQUE I data by subtracting out a constant error C which was separately determined for each filter. Figure 8-4 is a graph of the measured total volume scattering coefficient versus the volume scattering function at 30 degrees for the OPAQUE II pseudo-photopic Filter 4 data. The lower curve is again based upon the median values derived from Barteneva (1960). The upper curve is the Barteneva values if a constant error C is added to the total volume scattering coefficient for Barteneva. The constant C was derived from the OPAQUE I data. This graph indicates that the same error apparently applies to the OPAQUE II data. There is slightly more scatter, but the correction should be the same or less for OPAQUE II and the scatter is in the direction of a larger error which does not appear reasonable.

Similar graphs of the data for OPAQUE II were made for the other three filters. In all cases, the stray light error is similar to the OPAQUE I error. Therefore, the same corrections were applied to the

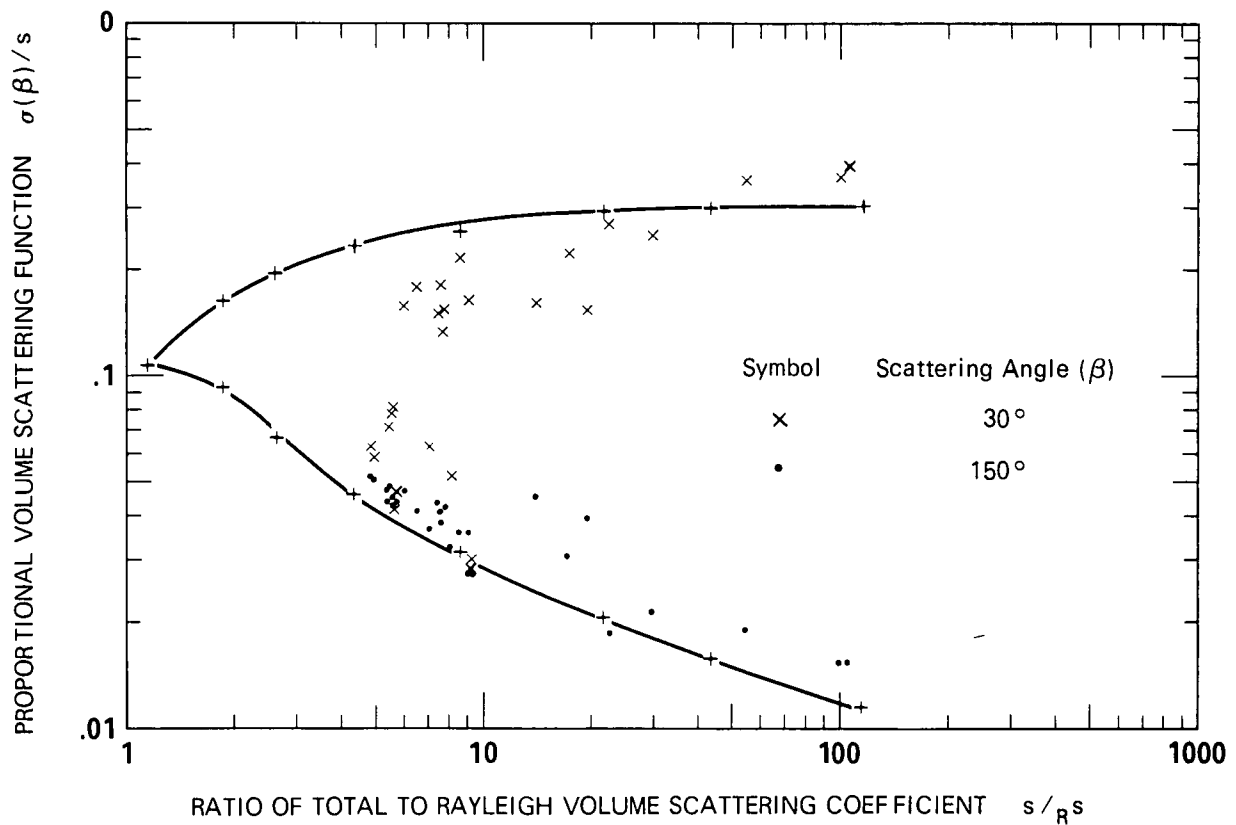

Fig. 8-3. Measured Proportional Volume Scattering Function Versus the Ratio of Total to Rayleigh Volume Scattering Coefficient for OPAQUE II Pseudo-Photopic Filter 4 Mean Wavelength 557 Nanometers.

OPAQUE II data as were applied to the OPAQUE I data. The measured total volume scattering coefficient was corrected by subtracting the OPAQUE I correction constants: $2.99\text{E-}5$ for Filter 2 mean wavelength 478 nanometers, $2.37\text{E-}5$ for Filter 4 mean wavelength 557 nanometers, $1.79\text{E-}5$ for Filter 3 mean wavelength 664 nanometers, and $1.40\text{E-}5$ for Filter 5 mean wavelength 765 nanometers. The total volume scattering coefficient data reported herein have been corrected by these constants.

Because the correction is a subtractive one, it should be noted that the scatter in the low magnitude data has been magnified, whereas the variability of the high magnitude data has been affected very little.

General Evaluation. The data reported for total volume scattering coefficient were measured during the vertical profile flight elements. Since many different flight patterns were used during OPAQUE II, they are summarized in Table 8.2. The first pattern listed is a (2 + 4) profile, two filters at four straight and level altitudes, with the vertical profile during ascent for the first filter, and during descent in the second filter. This flight pattern was illustrated in Fig. 4-1. The elapsed times during the vertical profile elements were summarized in Table 6.1. The elapsed time varied according to flight pattern and altitude interval, ranging from 2 to 68 minutes.

The data have been extrapolated upward to the nearest 300-meter altitude increment. These upward

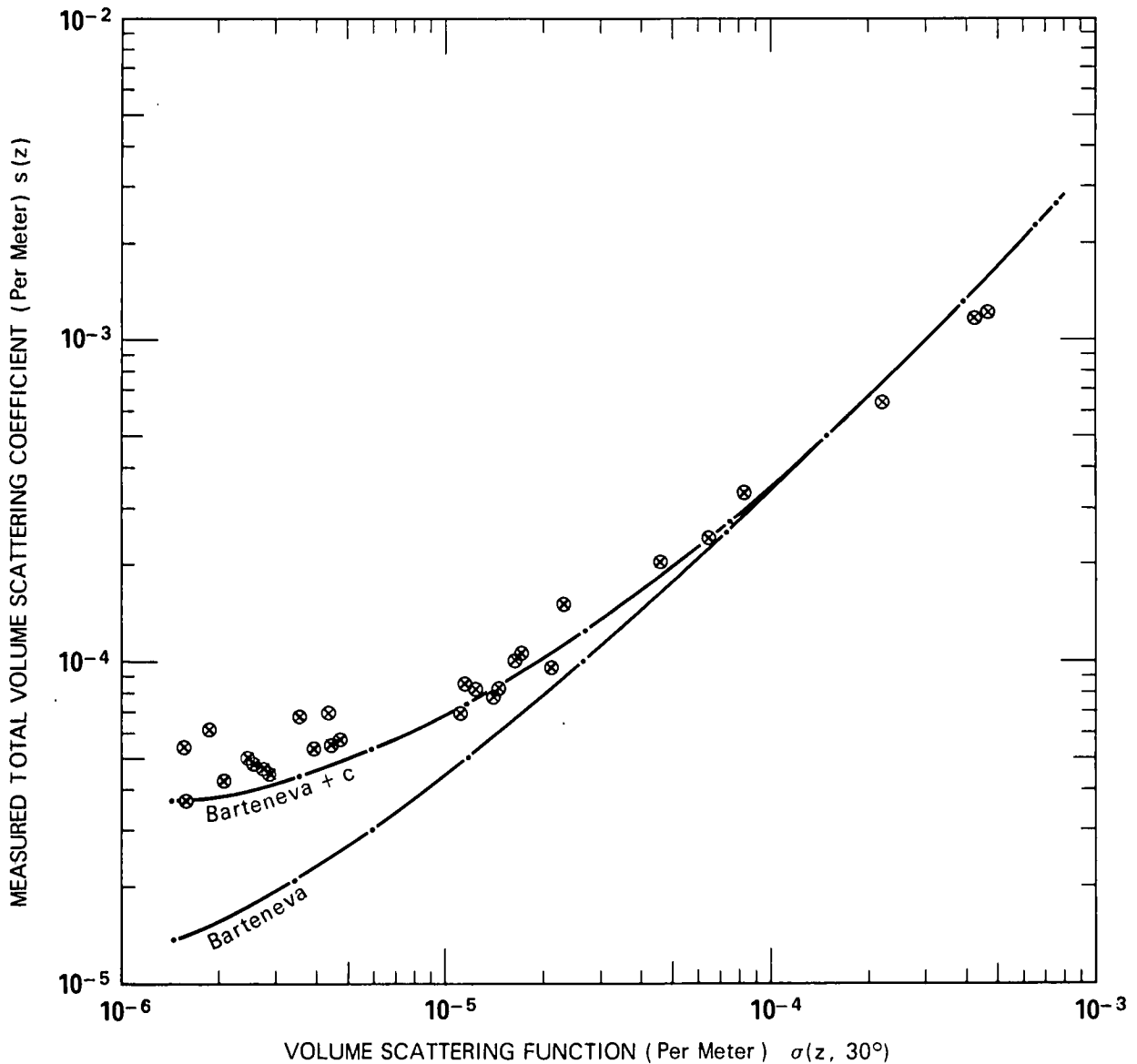

Fig. 8-4. Total Volume Scattering Coefficient Versus Volume Scattering Function at 30 Degrees for OPAQUE II Filter 4 Pseudo-Photopic Mean Wavelength 557 Nanometers, $C = 2.37 \times 10^{-5}$.

extrapolations are based upon the density ratios of the U.S. Standard Atmosphere, 1962 (equivalent to the 45°N Spring/Fall). The extrapolations appear on the graphs of total volume scattering coefficient as a slightly slanting dashed line. The upward extrapolations generally follow the prevailing trend of the data, and are over small altitude intervals. However, the upward extrapolation for Flight C-395 should be used with caution since the data indicate the presence of a high altitude haze layer which was increasing in opacity with time in addition to being spatially nonuniform.

For simultaneous data, the order of the scattering coefficient data by filter generally should be the

Table 8.2

Flight Patterns Used During OPAQUE II

Pattern	Description	Flights
(2+4)	Two filters at four straight and level altitudes	C-390, C-401
(1+4)	One filter at four straight and level altitudes	C-398
(2+3)	Two filters at three straight and level altitudes	C-395, C-399 (Filters 4 & 5), C-402
(2+2)	Two filters at two straight and level altitudes	C-391, C-392, C-394, C-397, C-399 (Filters 2 and 3)
V-PRO	Only partial straight and level altitudes	C-393, C-400

inverse of the mean wavelength of the filters, i.e., $s(\text{filter } 2) > s(4) > s(3) > s(5)$. Although the data were not simultaneous, the data above 1.5 kilometers for all the flights but Flight C-375 tend to follow this order. The high altitude data for Flight C-375 and all the low altitude data are much less consistent by filter, indicating a less homogeneous aerosol layer and/or a lack of aerosol stability with time.

Although generally in order spectrally, the data for Flight C-397 indicate the presence of a strong but unstable or localized haze layer between 1 and 1.5 kilometers during the measurements for Filter 2; this layer was not detected during the later measurements for the other 3 filters.

To more easily compare the scattering characteristics of the flights, the filter 4 (pseudo-photopic) total volume scattering coefficient profiles for each flight have been graphed in Figs. 8-5 and 8-6. Figure 8-5 contains the flights made in Germany and Denmark. Except for Flight C-395, the high altitude data for these flights show a fairly clear layer above 1.3 kilometers in the total volume scattering coefficient range of 1.2 to 7.0 E-5 per meter and a haze layer at the lower altitudes. Figure 8-6 contains the flights made in France. For these flights, except for Flight C-398, the high altitude data tend to have a clear layer above 2.5 kilometers in the total volume scattering coefficient range of 1.2 to 3 E-5 per meter and a haze layer at the lower altitudes.

A similar graph of data for Northern Europe in April and May 1976 [Fig. 8-8 of Duntley, *et al.* (1977)] indicates a clear area above 3 kilometers in the total volume scattering coefficient range of 1.5 to 6.5 E-5 per meter and one or more haze layers at the lower altitudes.

Extrapolations Downward to Ground Level. On all but one of the vertical profiles, it was possible to make airborne measurements down to 480 meters and occasionally as low as 270 meters. No ground level measurements of total volume scattering coefficient were made so the data have been extrapolated down to ground level. The extrapolations downward from 480 meters or less to ground level were based upon the density ratios of the U.S. Standard Atmosphere, 1962. Users should be aware that extrapolations made at these low altitudes involve substantial levels of uncertainty. Previous data indicate that the

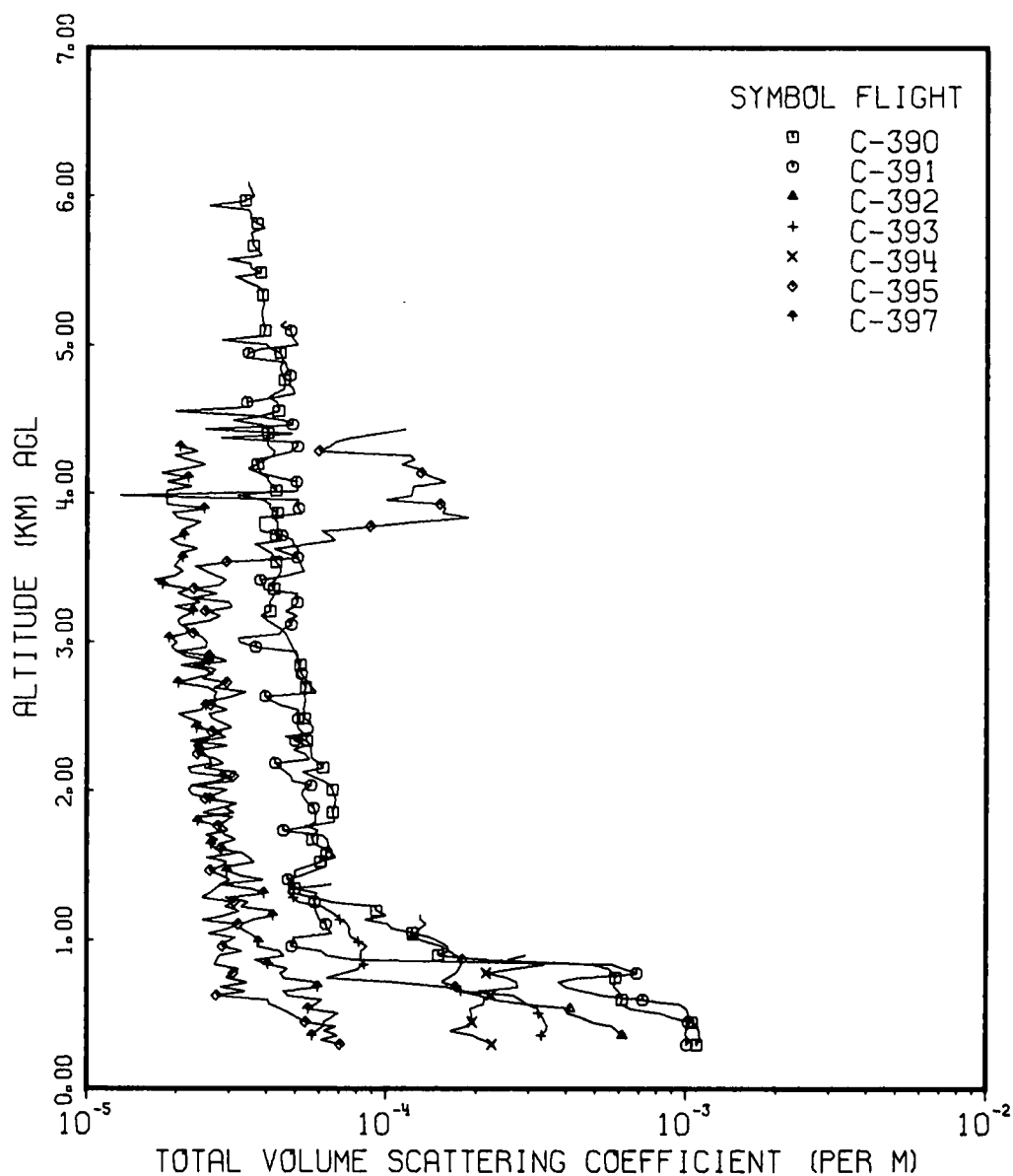

Fig. 8-5. Total Volume Scattering Coefficient for Filter 4 Pseudo-Photopic for Seven OPAQUE II Flights, 25 October Through 23 November 1976.

scattering coefficient profile near ground level is not a particularly well behaved function and often exhibits strong variations in structure. Extreme caution should be exercised in applying these extrapolated values to determinations involving low altitude, near horizontal paths of sight.

For Flight C-391, the lowest altitude of measurement for Filter 5 was 870 meters. At this altitude the aircraft was still above the haze layer. The data for the other three filters go down into the haze layer and they show a relatively stable relationship by wavelength at the lower altitudes, i.e., 330 to 510

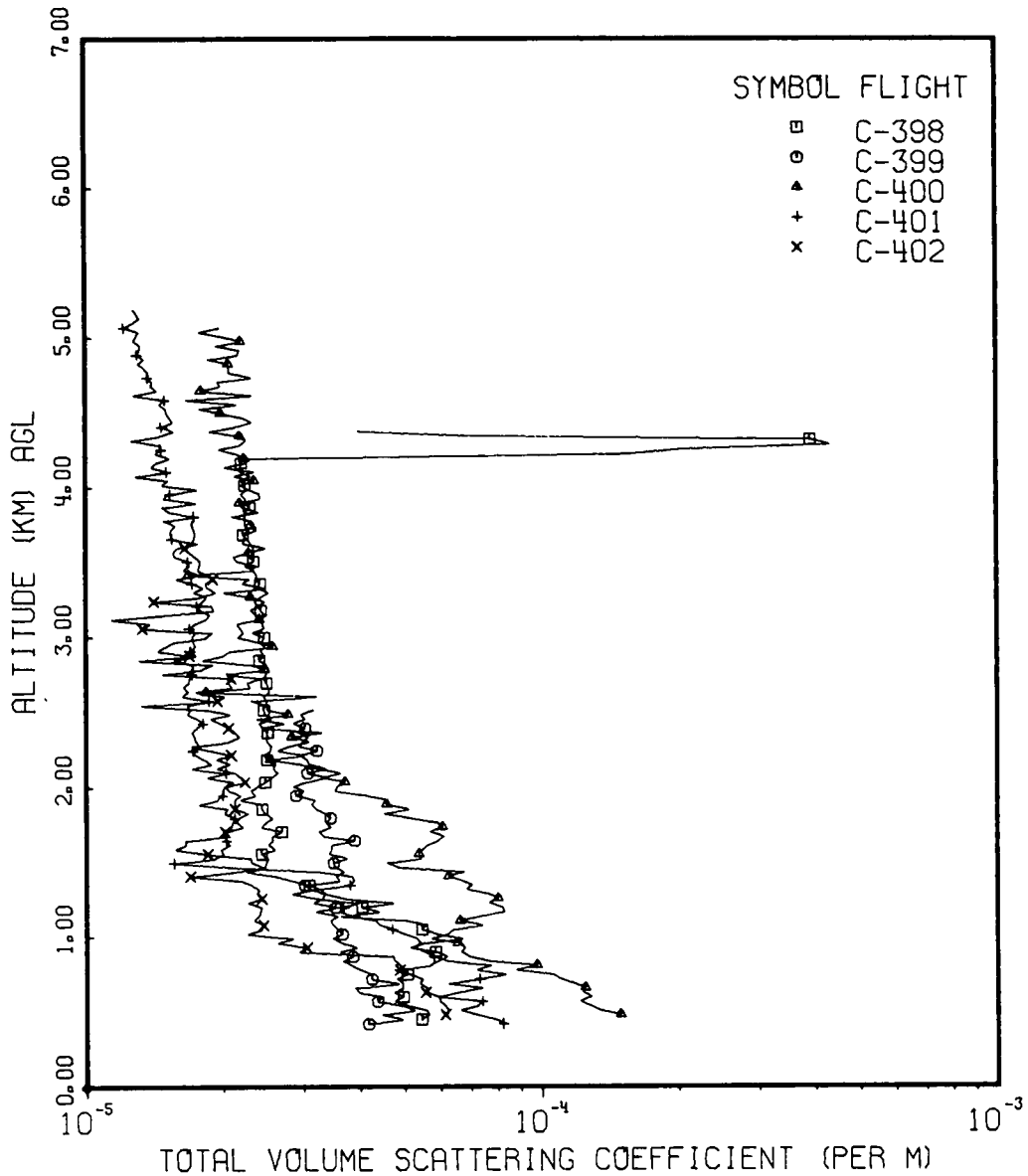

Fig. 8-6. Total Volume Scattering Coefficient for Filter 4 Pseudo-Photopic for Five OPAQUE II Flights, 2 December Through 6 December 1976.

meters. To obtain a more reasonable extrapolation for the filter 5 total volume scattering coefficient, we assumed the relationship in the 330 to 510 meter altitude interval to be,

$$s = K\lambda^{-n} \quad (8.1)$$

where the λ for each filter was the mean wavelength $\bar{\lambda}$. The average values for K and n were established for the altitude interval 330 to 510 meters to be .471 and -.974 respectively, i.e.,

$$s = .471\lambda^{-.974} \quad (8.2)$$

Using this relationship, the filter 5 total volume scattering coefficient was computed for 420 meters, the midpoint of the altitude interval of stable wavelength relationship.

Since the top of the haze layer appeared to be at 750 meters, the filter 5 total volume scattering coefficient was assumed to change from its computed midpoint value according to the density ratio from ground level to 750 meters. It was then interpolated linearly to the data value at the lowest altitude of measurement 870 meters.

All of the downward extrapolations appear on the graphs of total volume scattering coefficient in Section 7.3 as dashed lines.

Low Altitude Data. The total volume scattering coefficient data below 1.5 kilometers tend to be more complex than the high altitude data. There are generally one or more haze layers in the region 0 to 1.5 kilometers and the relationship by filter is less regular, indicating a less stable aerosol. To illustrate the complexities of the low altitude data, the total volume scattering coefficients for the 0 to 1.5 kilometer altitude interval are replotted on an expanded scale for each of the twelve OPAQUE II flights. These are presented in Figs. 8-7 through 8-9. As one might expect, even though the variability within this group of twelve flights is broad, the flights can be separated into about four general classes, all of which are normally represented in most sets of experimental flight data. This general classification by type of profile is illustrated below.

Table 8.3

Preliminary Classification of Low Altitude Scattering Coefficient Profiles

Classification	Class Description	Flight No.
Type I	No large, abrupt haze layer No spectral cross-over between profiles	C-395 C-398
Type II	No large, abrupt haze layer Numerous spectral cross-overs between profiles	C-397 C-399 C-400
Type III	Moderately abrupt haze layer Numerous spectral cross-overs between profiles	C-392 C-393 C-394 C-401 C-402
Type IV	Large, abrupt haze layer Numerous spectral cross-overs between profiles	C-390 C-391

Flight C-395
Rodby
Type I

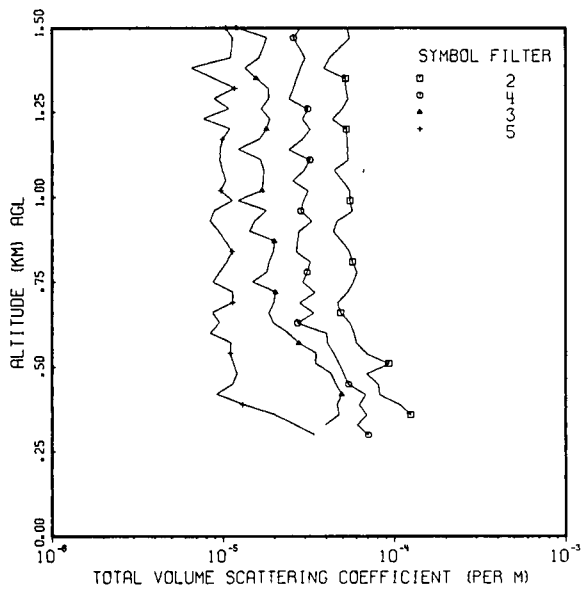

Flight C-398
Bruz
Type I

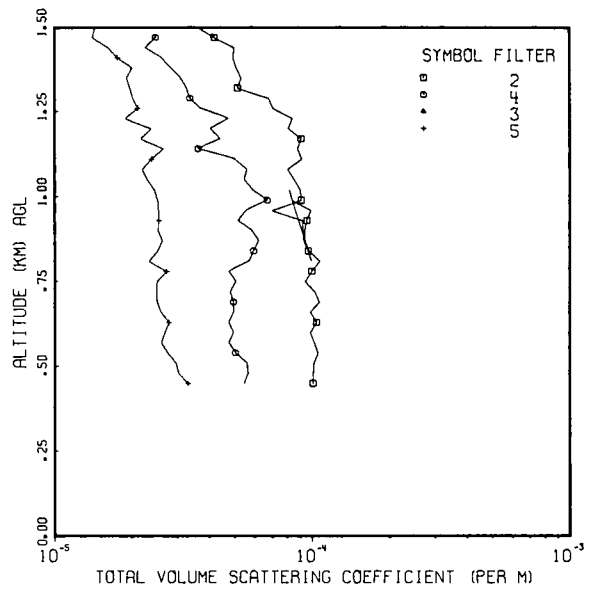

Flight C-397
Meppen
Type II

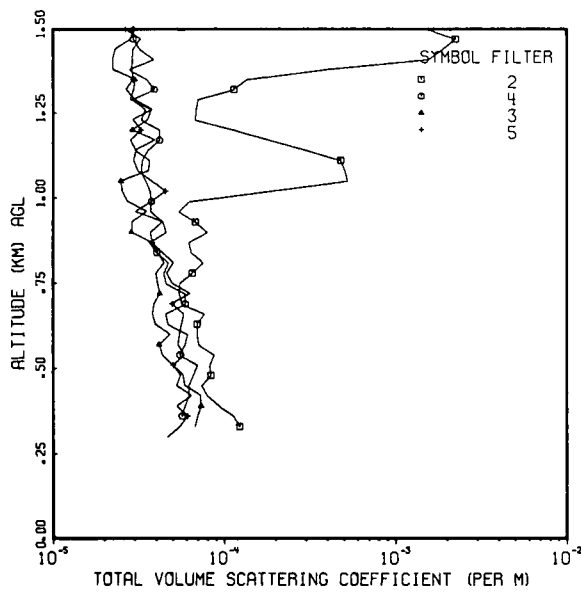

Flight C-399
Bruz
Type II

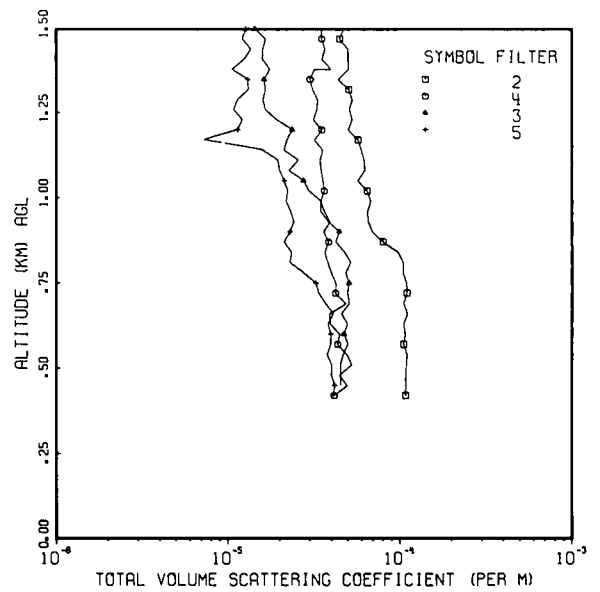
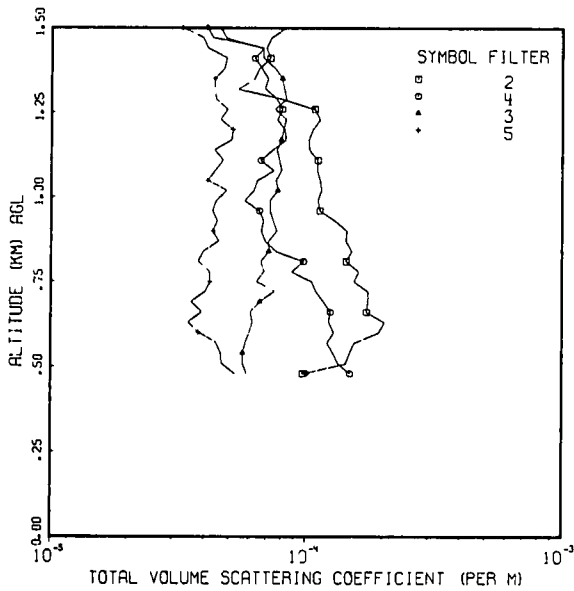
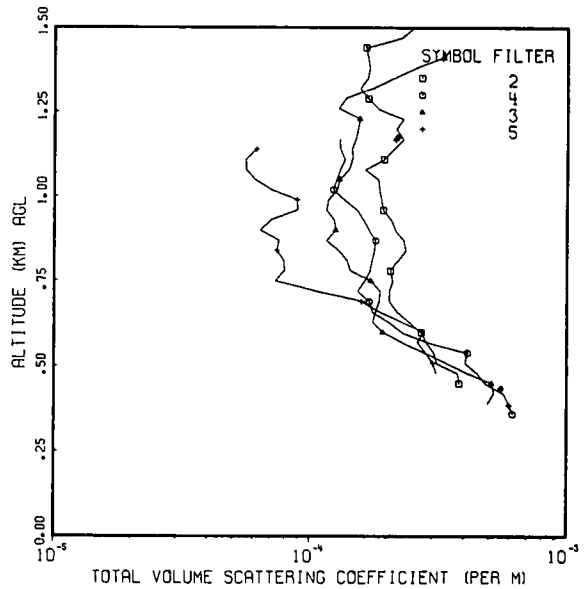

Fig. 8-7. Low Altitude Total Volume Scattering Coefficients for Type I and Type II Profiles.

Flight C-400
Bruz
Type II



Flight C-392
Meppen
Type III



Flight C-393
Meppen
Type III

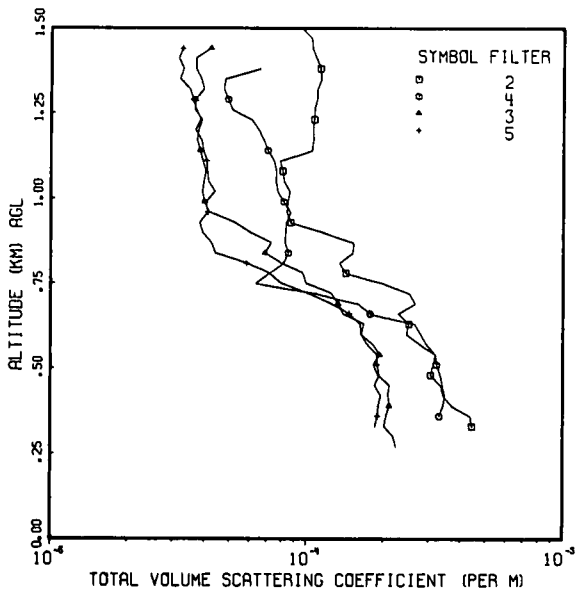

Flight C-394
Rodby
Type III

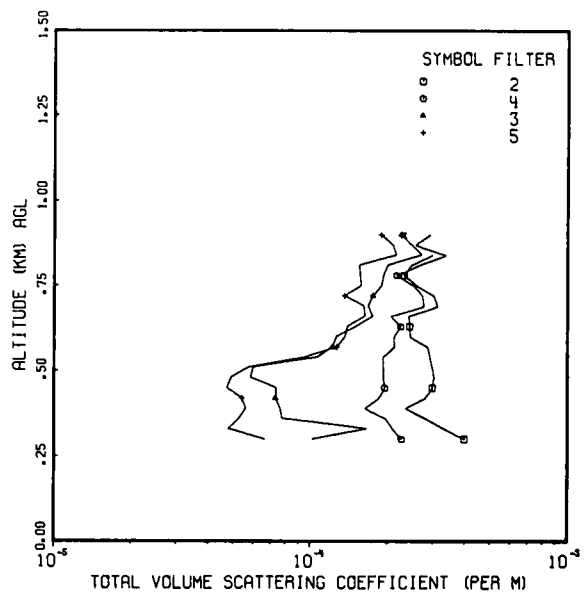
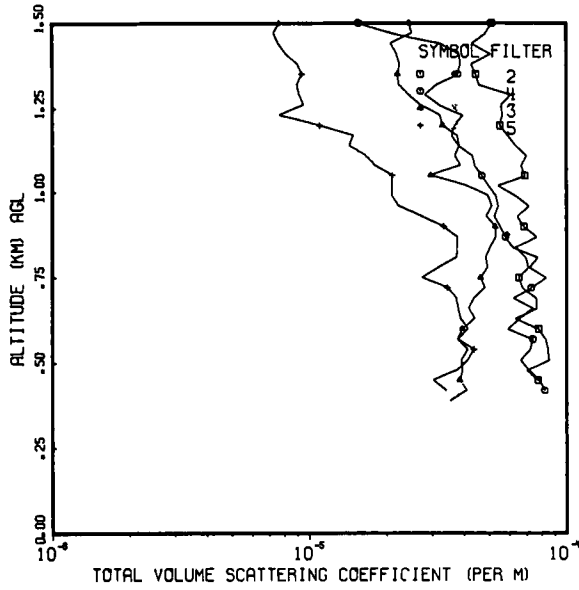
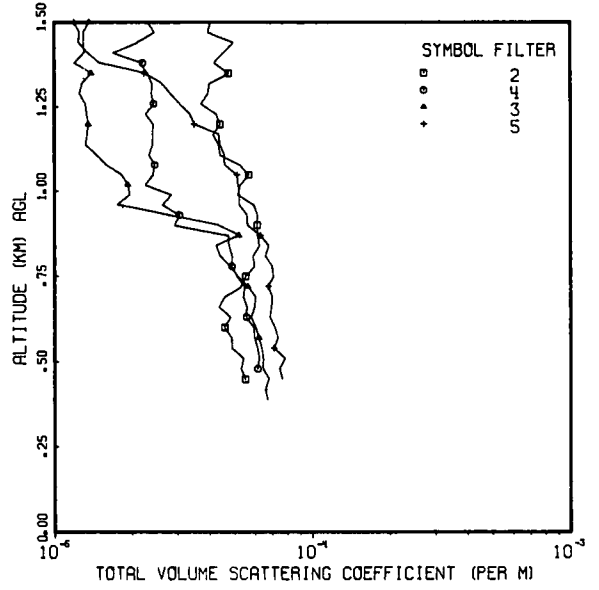

Fig. 8-8. Low Altitude Total Volume Scattering Coefficients for Type II and Type III Profiles.

Flight C-401
Bruz
Type III



Flight C-402
Bruz
Type III



Flight C-390
Rodby
Type IV

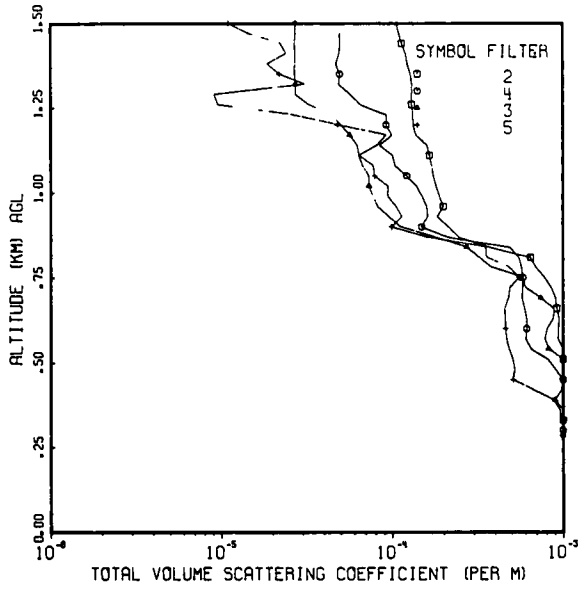

Flight C-391
Rodby
Type IV

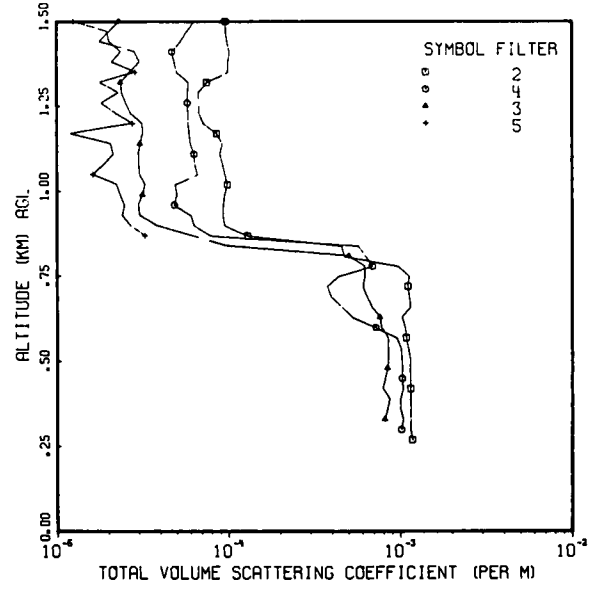

Fig. 8-9. Low Altitude Total Volume Scattering Coefficients for Type III and Type IV Profiles.

This typical distribution of low altitude profile classifications becomes particularly significant whenever the data application involves lines of sight restricted to the low altitude regime. The erroneous assumption that the low level atmosphere is always a well behaved Type I environment may easily result in the development of severely misleading values of beam and contrast transmittances.

When the measurements at the lowest altitude indicate some abnormality, such as being out of order by filter, the downward extrapolations retain the offsets of the last data points regardless of the general relationship of the measured data at the higher altitudes. This irregularity by filter at low altitude is apparent in Flights C-390, C-392, C-397, C-399, C-400, C-401, and C-402. Since both the equivalent attenuation length and beam transmittance are calculated between ground level and a specified altitude, they are greatly affected by the low altitude to ground level extrapolation, and will reflect these spectral irregularities.

Desirability of Ground Level Data. Comparison of ground level data with downward extrapolations from airborne data taken in Southeast Asia during SHEDLIGHT, Duntley, *et al.* (1970) Table 7.22, indicated the importance of concurrent air and ground station operation for full documentation of the total volume scattering coefficient profile. The ground station measurement provides the anchoring ground level value which completes the altitude to ground level profile. Without this ground level measurement, any downward extrapolation must always involve a finite degree of uncertainty.

To obtain a measure of this uncertainty, the ground level value, extrapolated by the density ratio from the lowest altitude airborne measurement, has been divided by the measured ground level value of total volume scattering coefficient for the SHEDLIGHT data. These ratios are summarized in Table 8.4. For the SHEDLIGHT data, most of the extrapolated values were lower than the measured values. Similar ratios for additional deployments during which ground stations operated concurrently with airborne measurements are also summarized in Table 8.4. They are presented chronologically: HAVEN VIEW I in southern Germany, April through June 1970, reported in Duntley, *et al.* (1972a); ATOM in central New Mexico, October and November, 1970, reported in Duntley, *et al.* (1972b); HAVEN VIEW II in northern Germany, May and June 1973, reported in Duntley, *et al.* (1976); and SEEKVAL in western Washington, July, 1974, reported in Duntley, *et al.* (1975a). The extrapolations to ground level from the measurement at the lowest airborne altitude were not included in the reports listed above, but the ground level measurements and all the airborne measurements were reported.

In contrast to the SHEDLIGHT data, the extrapolated values for most of HAVEN VIEW I and much of ATOM were higher than the ground-based measurements. Both HAVEN VIEW II and SEEKVAL have ratios indicating extrapolated values that were smaller than the ground-based measurements, as were those of SHEDLIGHT.

To get an idea of the level of uncertainty inherent in "using" the extrapolated value in place of the measured ground-level value, we computed the fractional standard deviation of the extrapolated value from the ground-based value. These fractional standard deviations are presented in Table 8.5. The fractional standard deviation can be interpreted as the absolute value of the ratio minus one. That is, if the ratios in Table 8.4 are designated as R , the fractional standard deviation equals $|R - 1|$. Thus, the overall fractional standard deviation .47 for all the filters and all the deployments indicates that for 67 percent of the cases, R lies between 0.53 and 1.47. This level of uncertainty is relatively high. Concurrent ground-based measurements of total volume scattering coefficient are indeed high desirable.

Table 8.4

Ratio of Extrapolated-to-Measured Ground Level Total Volume Scattering Coefficient

PROJECT SHEDLIGHT

Flight No.	Date	Ratio of Extrapolated-to-Measured Ground Level s					Altitude (m) of Lowest VPRO Measurement				
		Filter 1 $\bar{\lambda} = 478$	Filter 2 $\bar{\lambda} = 516$	Filter 5 $\bar{\lambda} = 532$	Filter 3 $\bar{\lambda} = 664$	Filter 4 $\bar{\lambda} = 745$	Filter 1	Filter 2	Filter 5	Filter 3	Filter 4
C-87	12 Oct 68	.75	.88	.81	1.01	.83	183	183	244	244	183
C-881	19 Oct 68	.87	.73	.87	.67	.61	213	183	183	152	183
C-92	9 Mar 69	.69	.63	.80	.61	.40	152	152	183	213	152

PROJECT HAVEN VIEW I

Flight No.	Date	Ratio of Extrapolated-to-Measured Ground Level s				Altitude (m) of Lowest VPRO Measurement			
		Filter 2 $\bar{\lambda} = 478$	Filter 6 $\bar{\lambda} = 532$	Filter 5 $\bar{\lambda} = 557$	Filter 3 $\bar{\lambda} = 664$	Filter 2	Filter 6	Filter 5	Filter 3
C-134	25 May 70	1.36	1.31	1.29	1.42	330	180	270	390
C-137	28 May 70	1.34	1.37	1.30	1.39	360	360	270	420
C-138	29 May 70	1.23	1.87	1.99	1.32	270	360	300	360
C-139	3 Jun 70	1.02	1.10	.98	1.05	180	300	240	240
C-142	6 Jun 70	.84	.82	.57	.83	780	1140	1110	900
C-143	6 Jun 70	1.23	1.39	2.08	1.22	360	270	360	450

PROJECT ATOM

Flight No.	Date	Ratio of Extrapolated-to-Measured Ground Level s				Altitude (m) of Lowest VPRO Measurement			
		Filter 2 $\bar{\lambda} = 478$	Filter 5 $\bar{\lambda} = 557$	Filter 3 $\bar{\lambda} = 664$	Filter 4 $\bar{\lambda} = 765$	Filter 2	Filter 5	Filter 3	Filter 4
C-152	26 Oct 70	1.44	1.38	1.62	1.43	780	780	750	750
C-154	28 Oct 70	1.09	1.07	1.19	1.12	630	690	600	630
C-155	30 Oct 70	1.03	1.00	1.12	1.15	690	660	690	660
C-157	3 Nov 70	.95	.90	1.05	.91	570	660	660	690
C-158	4 Nov 70	1.00	.93	.92	.71	570	600	600	570

Table 8.4 (cont.)

Ratio of Extrapolated-to-Measured Ground Level Total Volume Scattering Coefficient

PROJECT HAVEN VIEW II

Flight No.	Date	Ratio of Extrapolated-to-Measured Ground Level s				Altitude (m) of Lowest VPRO Measurement			
		Filter 2 $\bar{\lambda} = 478$	Filter 4 $\bar{\lambda} = 557$	Filter 3 $\bar{\lambda} = 664$	Filter 5 $\bar{\lambda} = 765$	Filter 2	Filter 4	Filter 3	Filter 5
C-273	16 May 73	.33	.34	.30	.25	240	270	210	240
C-279	3 Jun 73	.57	-	.48	-	270	-	270	-
C-280	4 Jun 73	-	.33 .38	-	-	-	240 330	-	-
C-281	5 Jun 73	-	.26	-	.22	-	330	-	330
C-282	5 Jun 73	-	.39 .37	-	-	-	180 210	-	-
C-288	13 Jun 73	.57	.73	.45	.33	240	360	300	270
C-289	14 Jun 73	.39	.34	.32	.16	300	240	390	180

PROJECT SEEKVAL

C-351	13 Jul 74		.60 .71				60 90		
C-352	14 Jul 74		.36 .34				60 330		
C-354	16 Jul 74		.47 .34				270 120		
C-357	20 Jul 74		.34 .25				120 360		
C-358	21 Jul 74		.43 .39				300 60		
C-359	23 Jul 74		.59 .79				120 60		
C-360A	28 Jul 74		.21 .37				150 90		
C-360B	28 Jul 74		.34 .39				90 210		

Table 8.5

Fractional Standard Deviation of Extrapolated Value From Ground-Based Measurement of Total Volume Scattering Coefficient

Deployment	Number of Values Per Filter	Fractional Standard Deviation								Total Number of Values
		$\bar{\lambda}$ 478	516	532	557	664	745	765	All Filters	
SHEDLIGHT	3	.30	.33	.22		.36	.52		.30	15
HAVEN VIEW I	6	.27		.49	.71	.32			.45	24
ATOM	5	.23			.20	.33		.28	.24	20
HAVEN VIEW II	4	.63				.71		.88		
	8				.66				.65	20
SEEKVAL	16				.61				.61	16
All Deployments		.34	.33	.40	.58	.40	.52	.57	.47	95

It would also be highly desirable to have a direct measure of the total volume scattering coefficient profiles between ground level and what is now our lowest altitude of airborne measurement. This, however, while desirable, is not as simple to achieve as the concurrent airborne and ground-based measurements.

Comparison to Visibility. The meteorological estimates of horizontal visibility VV have been related to the attenuation coefficient α by Douglas and Young (1945), and hence may be related to the scattering coefficient in the absence of absorption by

$$VV = \ln 18/\alpha \approx 3/s \quad (8.3)$$

An additional discussion of this relationship is presented by Middleton (1952). Visibility values for the low altitude straight and level flight elements based on Eq. 8.3 are given in column 3 of Table 8.6. The airborne visibilities lie close to or within the span of the weather station visibilities for the early flights (C-390 through C-392) which all have relatively low visibilities. The measured nephelometer values for the later flights (C-394 through C-402) indicate clearer air at low altitude along the flight track than at ground level at the weather stations.

Correlation With Relative Humidity. For the SEEKVAL data [Duntley, *et al.* (1975a)], an attempt was made to correlate the total volume scattering coefficient for filter 4 (pseudo-photopic) with the relative humidity. These data indicated an approximately linear relationship between the log of the ratio of the

Table 8.6

Low Altitude Visibility Based on Nephelometer Compared to
Meteorological Estimates from Weather Stations

Flight No. *	Time (GMT)	Visibility (Kilometers)		Station
		Airborne Nephelometer	Visibility Estimate Range	
C-390	1429	2.5	2.6 4.0 5.0 4.5	Kegnaes Fehmarnbelt Mön Hamburg
C-391	1209	2.7	3.0 2.0 6.0 3.5	Kegnaes Fehmarnbelt Mon Hamburg
C-392	1212	5.0	8.0-5.0 7.0 8.0	Eelde Lingen Twente
C-394	1225	12.2	6.0 10.0	Kegnaes Fehmarnbelt
C-395	1256	55.9	15.0 10.0 8.0	Kegnaes Fehmarnbelt Hamburg
C-398	1406	51.6	11.2 8.0 11.2 15.0	Rennes-St. Jacques St. Nazaire-Montoir Nantes-Chateau Bougon Anbers/Avrille
C-399	1116	48.1	11.2-25 11.2-15 11.2-30 11.2-15	Rennes-St. Jacques St. Nazaire-Montoir Nantes-Chateau Bougon Anbers/Avrille
C-401	1233	41.2	30.0-11.2 30.0-11.2 20.0	Rennes-St. Jacques Nantes-Chateau Bougon Anbers/Avrille
C-402	1324	39.2	11.2 11.2 12.0 11.2	Rennes-St. Jacques St. Nazaire-Montoir Nantes-Chateau Bougon Anbers/Avrille

*Flights C-393 and C-400 did not have low altitude ST & LV Filter 4 nephelometer data.

total volume scattering coefficient to the Rayleigh total volume scattering coefficient, $\log [s(z)/_R s(z)]$, and the relative humidity RH

$$\log s(z)/_R s(z) = 1.28 \frac{RH}{100} \quad (8.4)$$

This was for a flight track in western Washington over forest near an agricultural area, removed from major sources of industrial pollution and auto emissions

In an attempt to see if this relationship was equally valid for the OPAQUE II data, the nephelometer data from the straight and level flight elements have been put into ratio form and graphed as a function of relative humidity in Fig 8-10. The superimposed line is for the relationship indicated by Eq 8.4. Although there is a rough correlation between the ratio of total to Rayleigh volume scattering coefficient and the relative humidity, there is also a great deal of scatter. The relationship for the OPAQUE II data is far less clear cut than it was for the SEEKVAL data.

The correlation for the SEEKVAL data was based upon data taken during the vertical profile elements. It would be useful to see if the rougher correlation for the OPAQUE data which were averaged over a larger time and space interval during the straight and level flight elements remains similar for the shorter time interval vertical profile data. The volume of the vertical profile data and the wish to facilitate the availability of the data herein reported have precluded this quantitative analysis of the OPAQUE II vertical profile data, since the computation and graphing have not yet been automated.

Composite Graphs of RH and s A qualitative though informative comparison of the relative humidity and the total volume scattering coefficient measurements taken during the vertical profile flight elements may be made by examining the graphical displays of relative humidity in Section 6.1 and total volume scattering coefficient in Section 7.3.

A convenient method of assessing the degree of similarity, or the lack thereof, between the relative humidity profiles presented in Fig 6-3 and the total volume scattering coefficient profiles presented in Section 7, is to use the composite plots illustrated in Fig 8-11. From these composites one can readily determine the degree to which the two plots exhibit the same or similar structural characteristics. These paired plots of simultaneously recorded data sets represent an optional display form currently under development and should prove useful in guiding the analyst toward the goal of determining a more clearly defined relationship between the measured optical and meteorological properties of the atmosphere. It is anticipated that the increased use of these displays will accelerate our ability to select flights whose optical and meteorological characteristics are thoroughly enough documented to enable their use in firmly establishing their linking relationships.

The examples shown in Fig 8-11 were selected from eleven pairs of profile data measured during the OPAQUE II Filter 4 pseudo-photopic descents. These graphs were chosen to illustrate a slightly different situation from those presented in Duntley, *et al* (1977), where the distinction was made between high structural similarity throughout the altitude interval, and high similarity only at low altitude.

The data for Flights C-391 and C-395 show structural similarities at both high and low altitudes, but both have broad mid-altitude bands where the relative humidity profile is highly structured yet the scattering coefficient is relatively stable. It is of interest to note that on both flights, the upper and lower altitude regions of structural similarity both occur at relative humidities higher than 50 percent.

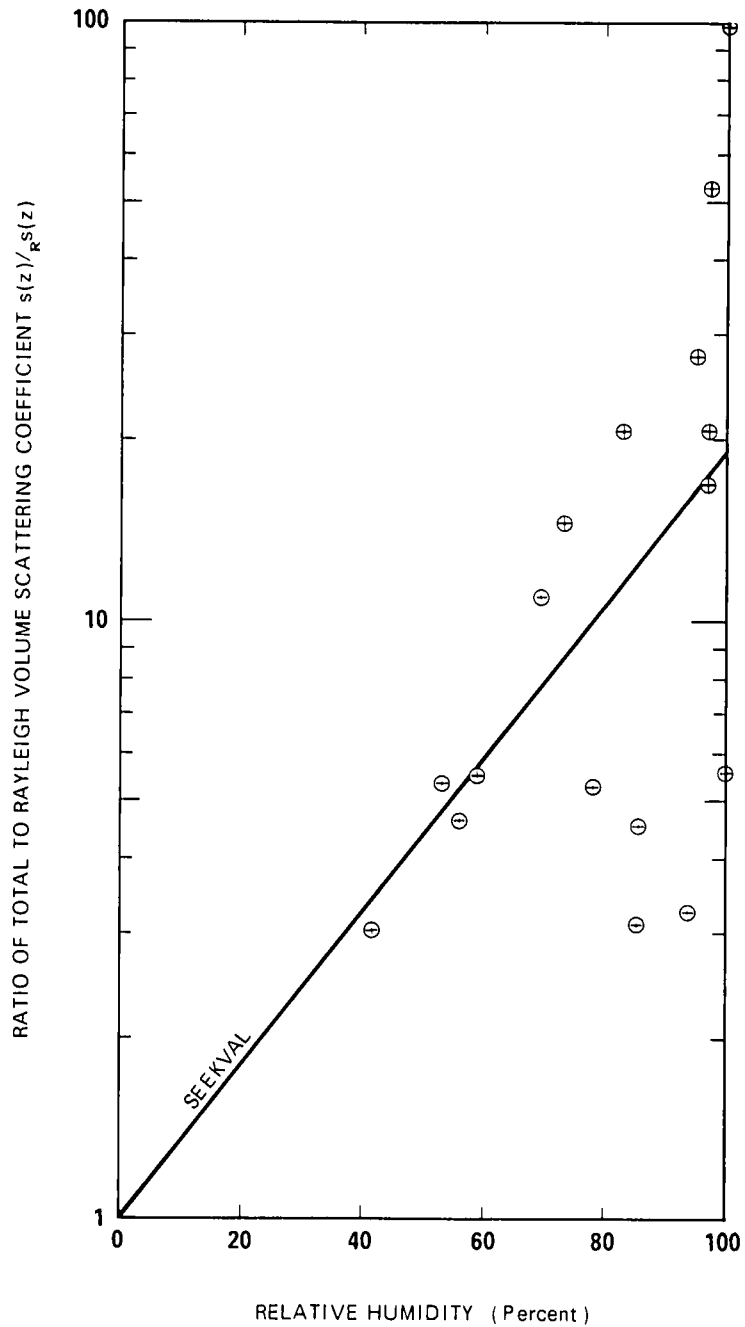

Fig. 8-10. Total Volume Scattering Coefficient for Filter 4 Pseudo-Photopic from Straight and Level Flight Elements as a Function of Relative Humidity for OPAQUE II.

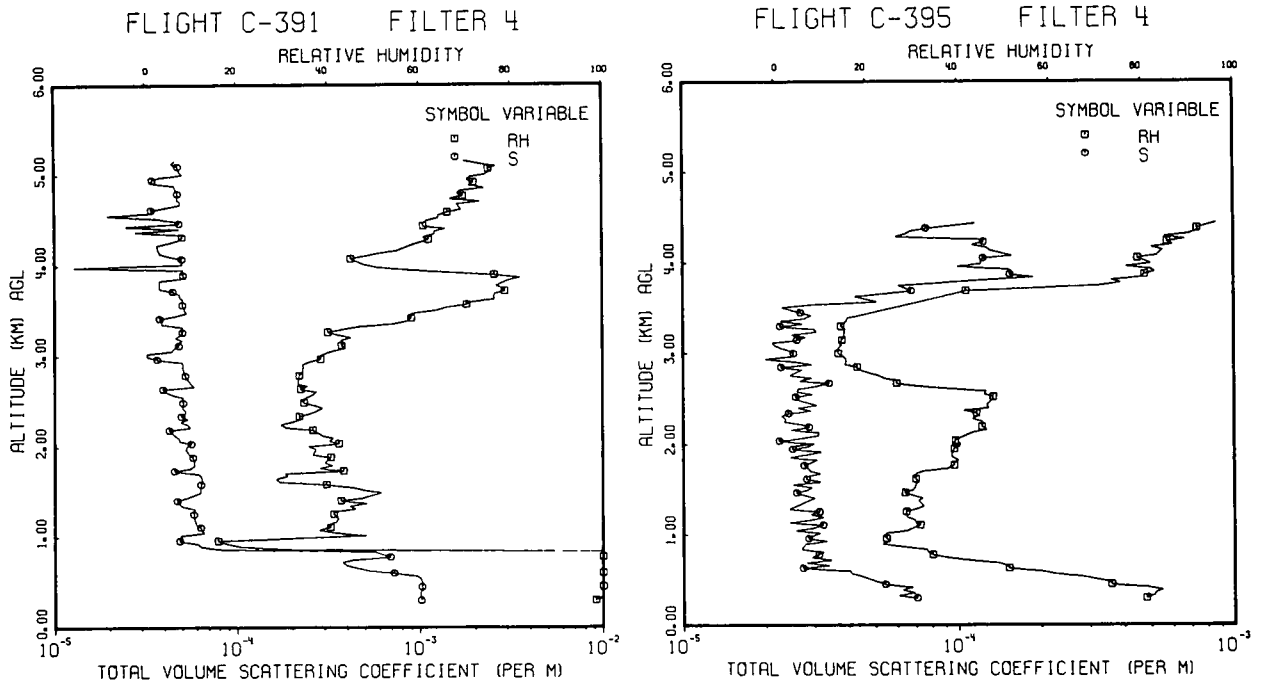

Fig. 8-11. Comparison of the Photopic Scattering Coefficient and Relative Humidity Profiles as Measured During Flights C-391 and C-395.

Conversely, where the relative humidity becomes smaller than about 40 to 50 percent, the structure in relative humidity profile is not as faithfully reflected by the scattering coefficient profile.

EQUIVALENT ATTENUATION LENGTH AND BEAM TRANSMITTANCE

Equivalent attenuation length is presented for the path between ground level and altitude. At ground level the equivalent attenuation length is the reciprocal of the total scattering coefficient $s(z)$. As altitude increases, the equivalent attenuation length shows the cumulative effect of summing $s(z)$ from ground level to altitude z .

The vertical beam transmittance starts at 1.0 at ground level and shows the cumulative effect of the summation of the total scattering coefficient with altitude.

For simultaneous data, or even for sequentially sampled data under reasonably stable and uniform aerosol conditions, the order by filter of the equivalent attenuation length \bar{L} and the beam transmittance T_r should vary directly as the mean wavelength of the filters, i.e., $\bar{L}(\text{Filter 2}) < \bar{L}(4) < \bar{L}(3) < \bar{L}(5)$. Much of the flight data do not follow this order, primarily because the low altitude total scattering coefficients are not generally in order by filter. The flights with some regularity of attenuation length with filter are Flight C-395 at low altitude, and Flights C-391, C-393, C-394, and C-398 at all altitudes.

Equivalent Attenuation Length and Beam Transmittance Examples. The equivalent attenuation length table can easily be used in Eq. 2.6 to obtain beam transmittance for various zenith angles for the upward path of sight and for various zenith angles for the downward path of sight.

EXAMPLES

- A. For an upward path of sight at 60 degree zenith angle, with an object altitude z_t at 1800 meters, Eq. 2.6 would be written

$$T_{3600}(0,60^\circ) = \exp \left\{ [-1800m/\bar{L}(1800m)] \sec 60^\circ \right\} .$$

Using the equivalent attenuation length for Flight C-391 filter 4, Eq. 2.6 becomes

$$T_{3600}(0,60^\circ) = \exp \left\{ [-1800m/2260m] 2 \right\} = 0.203.$$

- B. For a downward path of sight at a zenith angle of 135 degrees from a sensor altitude of 900 meters, Eq. 2.6 would become

$$T_{1273}(900m, 135^\circ) = \exp \left\{ [-900m/\bar{L}(900m)] |\sec 135^\circ| \right\} .$$

Again using the values from Flight C-391 filter 4, Eq. 2.6 becomes

$$T_{1273}(900m, 135^\circ) = \exp \left\{ [-900m/1210m] 1.414 \right\} = 0.349 .$$

IRRADIANCE

Downwelling. The downwelling irradiance was measured during the straight and level flight elements and during the vertical profiles on each flight. During the straight and level flight elements, the intended aircraft flight attitude was 2½ degrees nose high and the dual irradiator was oriented to be horizontal under these conditions. The pitch and roll measurements during the straight and level flight elements indicated that average aircraft attitude was such that the dual irradiator was within ±3 degrees of true horizontal during most of the flights. Downwelling irradiance values for the straight and level flight elements for each flight are presented in columns 7 through 10 in Table 8.7. The corresponding sun zenith angle for each filter and altitude are also presented in columns 3 through 6.

The low-altitude downwelling irradiance values for pseudo-photopic filter 4 for all the OPAQUE II flights are graphed in Fig. 8-12.

Table 8.7

Downwelling Irradiance Measured by the Dual Irradiometer
During the Straight and Level Flight Elements

Flight No.	Average Altitude (meters)	Sun Zenith Angle (Degrees)				Downwelling Irradiance (w/m ² μm)			
		Filter 2	Filter 4	Filter 3	Filter 5	Filter 2	Filter 4	Filter 3	Filter 5
C-390	6080	76.7	90.2	77.2	90.8	3.34E2	7.45E0	2.04E2	8.47E1
	3007	73.9	86.4	74.3	87.0	3.87E2	3.15E1	2.10E2	4.10E2
	1513	71.5	83.0	71.9	83.7	4.66E2	8.69E1	3.06E2	8.74E2
	307	69.6	80.1	69.9	80.8	4.14E2	7.52E1	2.91E2	1.60E3
C-391	5267	67.9	70.2	68.0	70.3	5.93E2	2.86E2	5.40E2*	3.26E2
	562	67.4	68.9	68.8	71.6	5.58E2	1.89E2	2.38E2*	1.54E2
C-392	1170	67.9	70.0	68.0	70.3	3.58E2	2.13E2	2.33E2	1.70E2
	410	67.6	68.7	67.6	68.9	3.18E2	2.99E2	2.55E2	1.66E2
C-393	307	68.3	-	-	-	1.56E2*	-	-	-
C-394	907	75.4	77.3	75.5	77.5	1.28E2	1.07E2	4.30E1	3.51E1
	253	74.7	76.2	74.8	76.4	8.84E1	1.03E2	5.88E1	3.34E1
C-395	4428	76.6	83.7	76.9	84.0	1.76E2	4.57E1	1.16E2	2.24E1
	1985	75.4	81.1	75.6	81.4	2.13E2	9.75E1	1.31E2	4.92E1
	311	79.1	78.2	79.6	78.6	1.52E2	1.32E2	1.25E2	4.58E1
C-397	4297	76.5	76.7	76.6	76.8	6.93E2*	4.40E2*	7.40E1*	1.14E2*
	317	74.1	75.5	75.4	78.1	5.41E2	1.57E2	1.94E2	2.29E1
C-398	4401	71.6	72.2	71.8	-	3.77E2	3.23E2	2.38E2	-
	2010	70.6	73.2	70.8	-	5.63E2	2.45E2	2.93E2	-
	809	70.1	74.4	70.2	-	4.61E2	3.17E2	2.24E2	-
	426	70.1	75.8	70.1	-	4.89E2	2.78E2	3.31E2	-
C-399	2565	-	70.2	-	70.3	-	3.85E2	-	2.72E2
	1347	71.8	70.2	71.3	70.2	5.10E2	3.41E2	3.74E2	1.57E2
	406	73.9	70.8	73.6	70.6	1.70E2	2.78E2	1.23E2	1.38E2
C-400	480	73.0	-	72.8	-	2.09E2	-	9.40E1	-
C-401	5175	70.4	75.7	70.4	76.1	5.09E2	2.81E2	3.20E2	1.04E2
	2105	70.7	73.6	70.6	74.0	4.73E2	2.86E2	3.01E2	1.24E2
	891	71.4	71.8	71.2	72.0	4.21E2	3.44E2	3.11E2	1.66E2
	413	72.6	70.9	72.3	71.0	3.76E2	1.97E2	2.70E2	1.33E2
C-402	3839	71.6	77.4	71.8	77.9	3.98E2	2.41E2	9.77E1	1.04E2
	1390	70.9	75.0	71.1	75.4	1.48E2	2.73E2	1.34E2	1.17E2
	424	70.6	-	70.6	-	4.56E2	-	1.81E2	-

*Pitch or roll of aircraft made irradiometer more than 3 degrees from true horizontal.

The symbols indicate the cloud categories described in Table 8.1. Since the altitudes for the lowest straight and level sequences for filter 4 ranged between only 295 and 443 meters above ground level, they can reasonably be compared to the ground-level values of Brown (1952). The illuminance values of Brown for unobscured sun, and partial cloud have been converted to irradiance units and depicted as solid curves in Fig. 8-12.

All but one of the low altitude OPAQUE II irradiances are less than the clear day irradiances of Brown. This seems reasonable since all of the flights took place on days with scattered to broken clouds or under overcast sky.

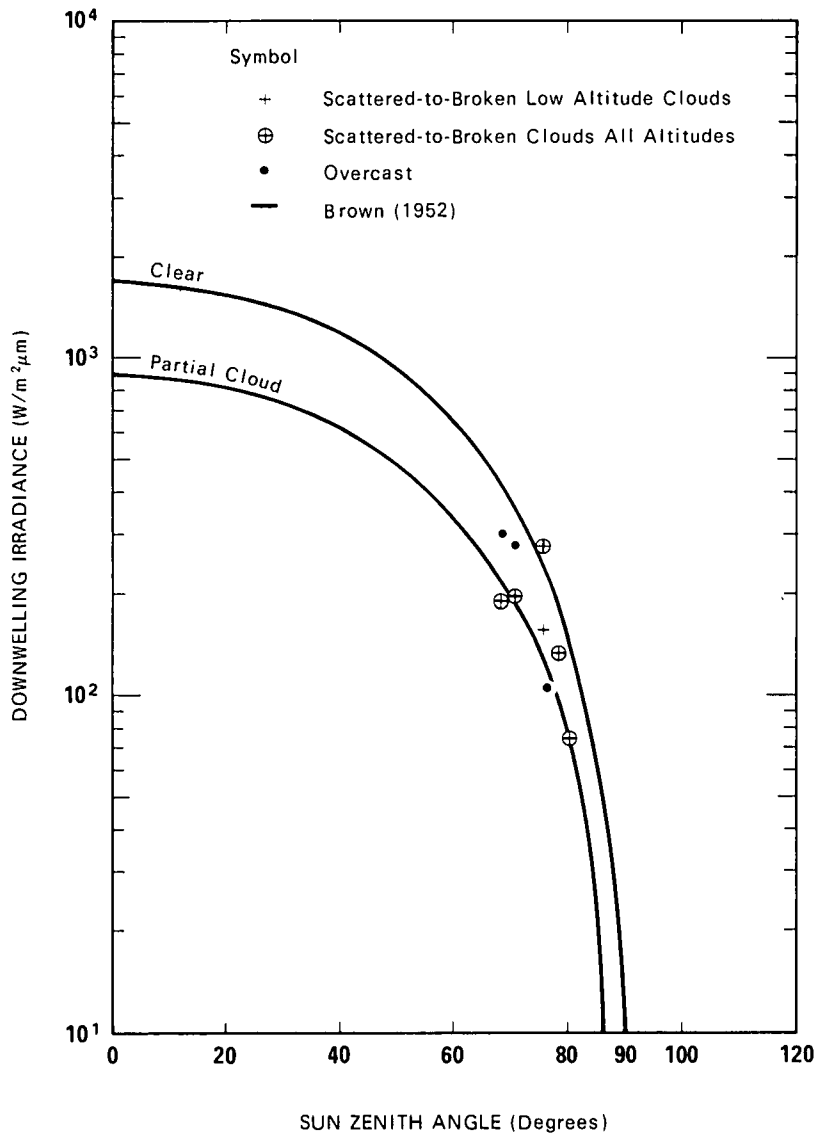

Fig. 8-12. Project OPAQUE II Low Altitude Downwelling Irradiance for Filter 4 Pseudo-Photopic Compared to Brown (1952).

The average pitch of the aircraft during the vertical profile sequences was +6.9 degrees during ascent and -1.2 degrees during descent so that the dual irradiator was roughly +4 degrees from horizontal during ascent and -4 degrees from horizontal during descent. The aircraft heading was generally cross sun to minimize this effect. Generally, however, the orientation of the dual irradiator during the vertical profile could not be kept within as close an angular tolerance as during the straight and level flight elements. Therefore, it is preferable to use the values from the straight and level sequences in Table 8.7 for the absolute values of downwelling irradiance and to use the vertical profile graphs in Section 7.3 to indicate the variability of downwelling irradiance with space and time during the flight.

The variance of the irradiator collector cap from true horizontal exceeded acceptable limits in one or more critical planes during four flights, C-391, C-392, C-393, and C-397. Hence, the following vertical profiles of irradiance should be used with caution:

Flight C-391, Filters 2, 4, and 3

Flight C-392, Filters 4, 3, and 5

Flight C-393, Filters 2, 4, and 3

Flight C-397, Filters 2 and 5

In the graphs of downwelling irradiance versus altitude in Section 7.3, the clear at high altitude flights, (cloud category 1) are reasonably regular at high altitude due to the absence of clouds, e.g., C-397 and C-400, filters 2 and 3. The minor variability at high altitude for C-397 may be due to excessive pitch and roll. The overcast flights, category 3, are generally slightly irregular with altitude, and the data are generally spectrally in order with filter 2 > 4 > 3 > 5 but with lots of crossovers, e.g., Flights C-392, C-393, C-394, and C-399. The remainder of the flights, those having scattered to broken clouds, have some stable areas with altitude and areas of great variability indicating clouds intermittently over the sun. The general order of data-taking was filter 2 during ascent, filter 3 during descent, filter 4 during ascent and finally filter 5 during the last descent. In general, for roughly comparable times the data are spectrally in order with filter 2 > 4 > 3 > 5. Major exceptions were the more variable portions of profile indicating clouds. A second major exception was Flight C-390 for filters 4 and 5 during sunset. At high altitude at roughly comparable times, the filter 5 downwelling irradiance was larger than the filter 4 downwelling irradiance. Since the dual irradiator was not always verifying its proper optical channel during the C-390 downwelling measurement of filter 5, this may or may not represent a real irradiance difference.

Downwelling irradiance for filter 4 pseudo-photopic has been graphed separately for the seven flights in Denmark and Germany in Fig. 8-13 and for the five flights in France in Fig. 8-14. The wide spread of values in Fig. 8-13 is primarily due to variations in sun zenith angle. Flights C-391, C-392, and C-393 were all in the 60 degree to 70 degree sun zenith angle range and they are at the higher portion of the graph. During the low altitude portion of Flight C-390, the sun zenith angle was about 82 degrees, but by the high altitude portion it had changed to 88 degrees. The sharp shift to the left at about 3 kilometers altitude occurs because of the time lapse during the intervening straight and level flight element. Flight C-395 has a sun zenith angle range of 80 degrees to 82 degrees. Flight C-394 is also relatively low in irradiance due to a relatively low sun zenith angle of 77 degrees and to being overcast. Flight C-397 is also about 76 degrees but is clear at high altitude.

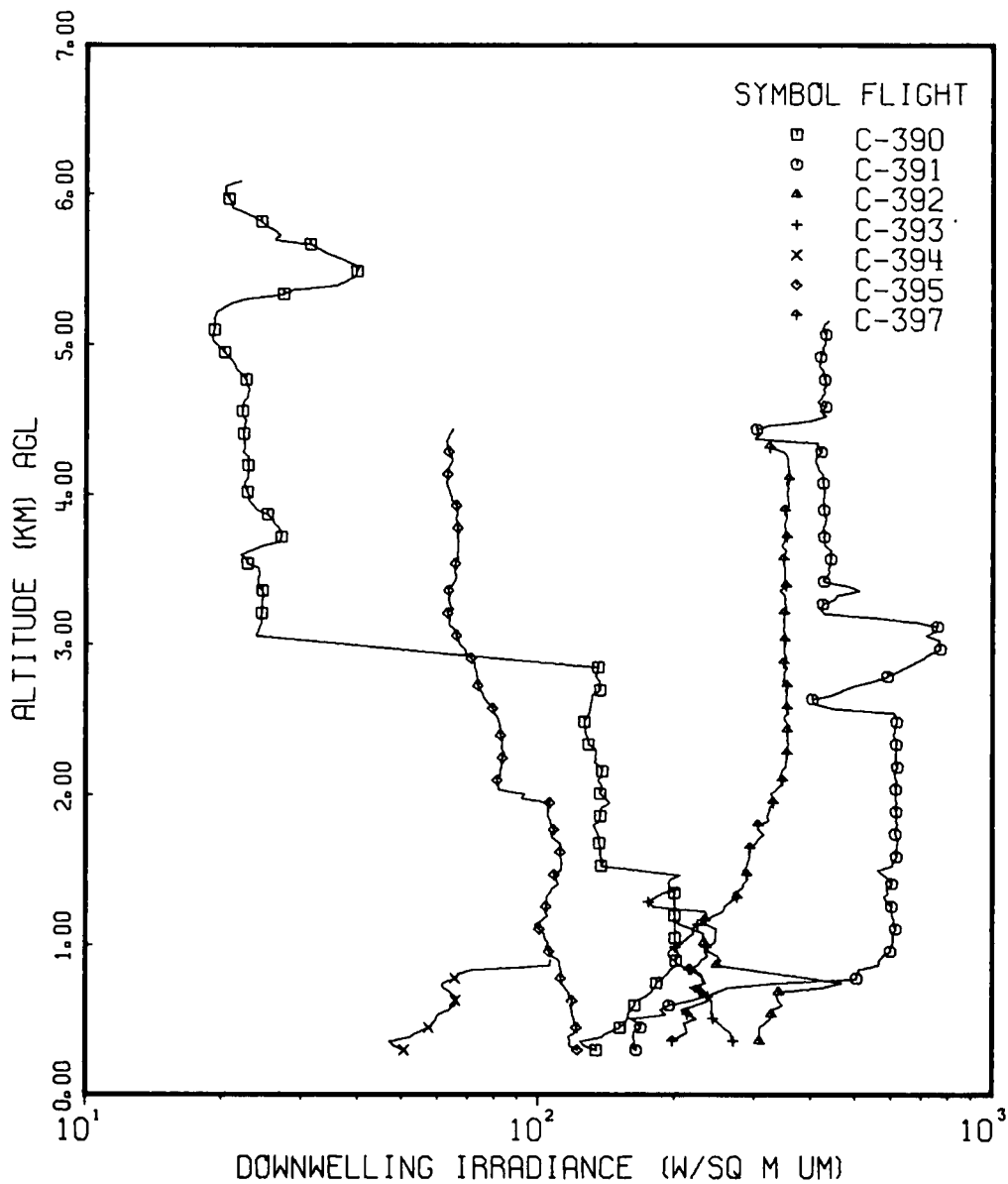

Fig. 8-13. Downwelling Irradiance for Filter 4 Pseudo-Photopic for Seven OPAQUE II Flights, 25 October Through 23 November 1976.

The irradiances in Fig. 8-14 have a smaller range since all the sun zenith angles lie between 70 and 75 degrees and most of the flights are in cloud category two, scattered to broken clouds all altitudes. Flight C-399, the only overcast case, has irradiance values very similar to the other four flights.

Albedo. The albedo is the ratio of the upwelling to downwelling irradiance. The albedos for the OPAQUE II airborne data are summarized in Table 8.8. The albedos are presented first for the flights over water, and then for the flights over land. The low altitude albedos for all filters (2, 3, 4, and 5) lie in a

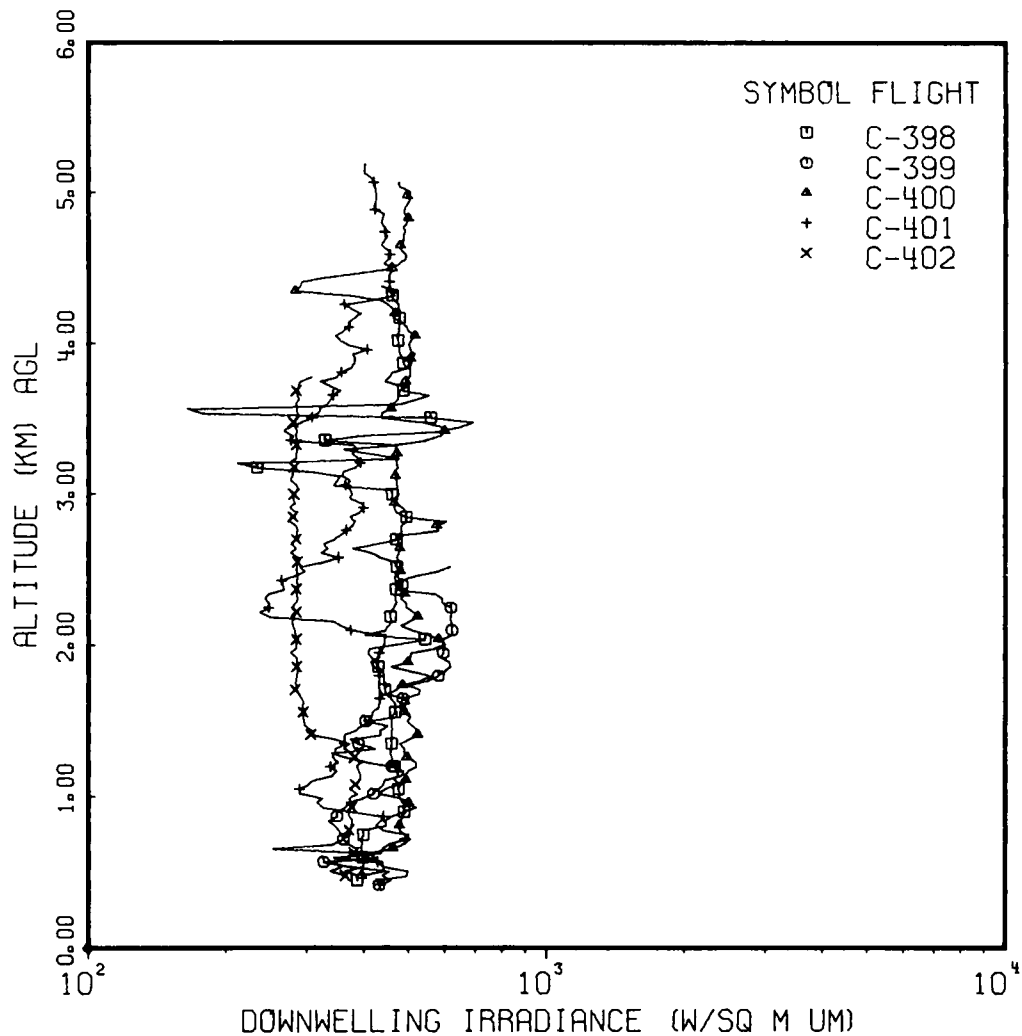

Fig. 8-14. Downwelling Irradiance for Filter 4 Pseudo-Photopic for Five OPAQUE II Flights, 2 December Through 6 December 1976.

reasonable range for cultivated fields with growing crops. Filter 4 values are expected to be slightly higher than the values for filters 2 and 3. The filter 5 values also show the expected high reflectance in the near infrared.

The low altitude albedos over water are also in a reasonable range for the low wind speeds. The over-the-water albedos are relatively neutral spectrally as is reasonable since most of the upwelling irradiance is from reflected sky and sun light and water reflectance is essentially neutral in this region of the spectrum. The high albedos at all altitudes for Flight C-390 are probably due to the heavy haze reported at all flight altitudes.

The albedos generally increase as expected with altitude. The large albedos at high altitude for Flight C-391 show the effect of clouds beneath.

Table 8.8

Albedo as Measured by the Dual Irradiometer During Straight and Level Flight Elements*

Flight No.	Average Altitude (meters)	Albedo				Track	Terrain Description
		Filter 2	Filter 4	Filter 3	Filter 5		
C-390	6080	.58	.46	.54	.59	Rodby, Denmark	Water, windspeed 1–4.1 mps, heavy haze all altitudes
	3007	.49	.94	.53	.86		
	1513	.42	.62	.42	.79		
	307	.22	.18	.24	.26		
C-391	5267	.78	–	.32	.60	Rodby, Denmark	Water, windspeed 5.1–9.3 mps, thick clouds, high altitude
	562	–	.13	.19	.97		
C-394	907	.090	.076	.072	–	Rodby, Denmark	Water, windspeed 2.1 mps
	253	.071	.058	.061	.043		
C-395	4428	.14	.11	.10	.10	Rodby, Denmark	Water, windspeed 4.1–10.8 mps
	1985	.12	.10	.10	.087		
	311	.10	.15	.066	.12		
C-392	1170	.14	.17	.15	.26	Meppen, Germany	Low lying flat farmlands, interspersed with dark woods and small towns
	410	.15	.12	.16	.28		
C-398	4401	.21	.20	.18	–	Bruz, France	Green fields interspersed with some brown areas and dark green trees
	2010	.18	.23	.17	–		
	809	.080	.12	.13	–		
	426	.063	.11	.086	–		
C-399	2565	–	.17	–	.28	Bruz, France	Green fields interspersed with some brown areas and dark green trees
	1347	.076	.22	.092	.38		
	406	.050	.095	.081	.34		
C-400	480	.050	–	.067	–	Bruz, France	Green fields interspersed with some brown areas and dark green trees

*Upwelling irradiance was not measured on Flights C-393 and C-397

Table 8.8 (cont.)

Albedo as Measured by the Dual Irradiometer During Straight and Level Flight Elements

Flight No.	Average Altitude (meters)	Albedo				Track	Terrain Description
		Filter 2	Filter 4	Filter 3	Filter 5		
C-401	5175	.17	.21	.13	.59	Bruz, France	Green fields interspersed with some brown areas and dark green trees
	2105	.12	.17	.11	.51		
	895	.087	.12	.13	.39		
	413	.064	.09	.08	.38		
C-402	3839	.20	.24	.19	.60	Bruz, France	Green fields interspersed with some brown areas and dark green trees
	1390	.10	.15	.08	.45		
	424	-	-	-	-		

8.3 SUMMARY

Twelve project data flights have been presented and evaluated with specific attention afforded to profiles of total volume scattering coefficient and downwelling irradiance. Selected meteorological measurements taken concurrently with these profile data have been included as background information and for structural comparisons with the scattering coefficient profiles.

Since the data for OPAQUE II represent flights made during late fall, and since some data missions were flown under poor to marginal weather conditions, there are broader variations in the profile data than in many of the previously reported data sets. These variations are welcome additions to the real world documentation afforded by this OPAQUE series.

Supplemental displays of low altitude scattering coefficient profile data have been added to illustrate the highly variable nature of these data in the near ground regime. Historical tabular data is also presented to support the illustration of this variability. The existence of this highly variable near ground regime, and the relative paucity of data documenting its true character should be of serious concern to analysts working with low altitude paths of sight.

It is recommended that the experimental program be adjusted to concentrate more heavily on documenting and evaluating the effects of these highly variable low altitude optical properties.

9. ACKNOWLEDGEMENTS

To be conducted successfully, Project OPAQUE II required the active support of many organizations and individuals. To all of those who so willingly contributed their skills, talents, and inspiration, the authors gratefully acknowledge their debt.

Dr Robert W Fenn, Chief, Atmospheric Optics Branch, AFGL
Scientific Counsel and Technical Monitor

Maj Ted S Cress, USAF, Project Organization and Coordination

Mr Raymond S Silva, Operational Services Division, AFGL, for
continuing logistical support and advice

4950th Test Wing (DOC & MAOP) Wright-Patterson Air Force Base, for all aircrew assignments

Lt Col Lou DeCarlo, Task Force Commander and Navigator

Lt Col Lyle T Jones, Task Force Commander and Navigator

Capt Norman A Rice, Aircraft Commander

Capt Ralph Brands, Pilot

T/Sgt Ronald Stewart, Flight Engineer

T/Sgt Larry D Henderson, Flight Engineer

S/Sgt Richie D Chronabery, Scanner

S/Sgt Beverly Wheel, Scanner

S/Sgt Anthony Martin, Crew Chief

T/Sgt Keith Mullins, Chief Maintenance Specialist

S/Sgt Steven Wood, Maintenance Specialist

S/Sgt Frank Duckworth, Maintenance Specialist

Sgt Daniel Aguilar, Maintenance Specialist

Mr Jack White, Maintenance Specialist

Visibility Laboratory, Technical Field Team

Mr Nils R Persson, Jr , Ground Station Crew

Mr George F Simas, Ground Station Crew

Mr Robert L Stapleford, Technical Flight Crew

Visibility Laboratory, Data Processing and Analysis Team

Mr Nils R Persson, Jr

Ms Janet E Shields

Ms. Catharine F. Edgerton
Mr. Steven J. Bettinger

Visibility Laboratory, Editorial and Reproduction Team

Mr. John C. Brown
Ms. Arlene C. Streed
Mr. James Rodriguez
Ms. Alicia G. Hill

COOPERATING SPECIALISTS

Physics Laboratory of the National Defense Research Organization (TNO)

P. O. Box 2864, The Hague, Netherlands

Ir T. Bakker
Ir J. Van Schie
Ir W.H.G. Ruhe
Hans Beekman

Meppen Artillery, Test Range
Erprobungsstelle 91 der Bundeswehr

447 Meppen, Germany

Herr Lichtenberg

Institute for Physics of the Atmosphere (Queen Air)

8031 Oberpfaffenhofen

Post Wessling, Federal Republic of Germany

Dr. Von Redwitz, MI/SCI
Helmut Gnatz, Copilot
Karl Thorenz, Mechanic

Centre d'Electronique de L'Armement (CELAR)

35170 Bruz, France

Mr. Marius Thorat
Mr. Albert Seven

Lorient/Lann Bihou Air Base

Frigate Capt. Montanier, Base Commander

Capt. Ruty, Operations Officer

10. REFERENCES

- Barteneva, O. D. (1960), "Scattering Functions of Light in the Atmospheric Boundary Layer," Bull. Acad. Sci. U.S.S.R., Geophysics Series, 1237 – 1244.
- Beutell, R. G. and A. W. Brewer (1949), "Instruments for the Measurement of the Visual Range," J. Sci. Instr. **26**, 357 – 359.
- Boileau, A. R. (1964), "VI. Atmospheric Properties," Appl. Opt. **3**, 570 – 581.
- Brown, D. R. E. (1952), Natural Illumination Charts, Report 374-1, Project Ns-714-100, Department of the Navy, Bureau of Ships, Washington, D. C.
- Douglas, C. A. and L. L. Young (1945), "Development of Transmissometer for Determining Visual Range," U. S. Department of Commerce, Civil Aeronautics Administration, Washington, D. C., Technical Development Report No. 47.
- Duntley, S. Q., A. R. Boileau, and R. W. Preisendorfer (1957), "Image Transmission by the Troposphere I," J. Opt. Soc. Am. **47**, 499 – 506.
- Duntley, S. Q., R. W. Johnson, and J. I. Gordon (1964), "Ground-Based Measurements of Earth-to-Space Beam Transmittance, Path Radiance, and Contrast Transmittance," University of California, San Diego, Scripps Institution of Oceanography, Visibility Laboratory, Tech. Doc. Report No. AL-TDR-64-245.
- Duntley, S. Q. (1969), "Directional Reflectance of Atmospheric Paths of Sight," Duntley Rep. No. 69-1.
- Duntley, S. Q., R. W. Johnson, J. I. Gordon, and A. R. Boileau (1970a), "Airborne Measurements of Optical Atmospheric Properties at Night," University of California, San Diego, Scripps Institution of Oceanography, Visibility Laboratory, SIO Ref. 70-7, AFCRL-70-0137.
- Duntley, S. Q., C. F. Edgerton, and T. J. Petzold (1970b), "Atmospheric Limitations on Remote Sensing of Sea Surface Roughness by Means of Reflected Daylight," University of California at San Diego, Scripps Institution of Oceanography, Visibility Laboratory, SIO Ref. 70-27.
- Duntley, S. Q., R. W. Johnson, and J. I. Gordon (1972a), "Airborne Measurements of Optical Atmospheric Properties in Southern Germany," University of California, San Diego, Scripps Institution of Oceanography, Visibility Laboratory, SIO Ref. 72-64, AFCRL-72-0255.
- Duntley, S. Q., R. W. Johnson, and J. I. Gordon (1972b), "Airborne and Ground-Based Measurements of Optical Atmospheric Properties in Central New Mexico," University of California, San Diego, Scripps Institution of Oceanography, Visibility Laboratory, SIO Ref. 72-71, AFCRL-72-0461.

- Duntley, S. Q., R. W. Johnson, and J. I. Gordon (1972c), "Airborne Measurements of Optical Atmospheric Properties, Summary and Review," University of California, San Diego, Scripps Institution of Oceanography, Visibility Laboratory, SIO Ref. 72-82, AFCRL-72-0593.
- Duntley, S. Q., R. W. Johnson, and J. I. Gordon (1974), "Airborne and Ground-Based Measurements of Atmospheric Properties in Southern Illinois," University of California, San Diego, Scripps Institution of Oceanography, Visibility Laboratory, SIO Ref. 74-25, AFCRL-TR-74-0298.
- Duntley, S. Q., R. W. Johnson, and J. I. Gordon (1975a), "Airborne Measurements of Optical Atmospheric Properties in Western Washington," University of California, San Diego, Scripps Institution of Oceanography, Visibility Laboratory, SIO Ref. 75-24, AFCRL-TR-75-0414.
- Duntley, S. Q., R. W. Johnson, and J. I. Gordon (1975b), "Airborne Measurements of Optical Atmospheric Properties, Summary and Review II," University of California, San Diego, Scripps Institution of Oceanography, Visibility Laboratory, SIO Ref. 75-26, AFCRL-TR-75-0457.
- Duntley, S. Q., R. W. Johnson, and J. I. Gordon (1976), "Airborne Measurements of Optical Atmospheric Properties in Northern Germany," University of California, San Diego, Scripps Institution of Oceanography, Visibility Laboratory, SIO Ref. 76-17, AFGL-TR-76-0188.
- Duntley, S. Q., R. W. Johnson, and J. I. Gordon (1977), "Airborne Measurements of Atmospheric Volume Scattering Coefficients in Northern Europe, Spring 1976," University of California, San Diego, Scripps Institution of Oceanography, Visibility Laboratory, SIO Ref. 77-8, AFGL-TR-77-0078.
- Edgerton, C. F. (1967), "Relationship Between Meteorological Conditions and Optical Properties of the Atmosphere," University of California, San Diego, Scripps Institution of Oceanography, Visibility Laboratory, SIO Ref. 67-27.
- Gordon, J. I., J. L. Harris, and S. Q. Duntley (1963), "Earth-to-Space Contrast Transmittance Measurements from Ground Stations," University of California, San Diego, Scripps Institution of Oceanography, Visibility Laboratory, SIO Ref. 63-2.
- Gordon, J. I. (1969), "Model for a Clear Atmosphere," *J. Opt. Soc. Am.* **59**, 14 – 18.
- Gordon, J. I., J. L. Harris, Sr., and S. Q. Duntley (1973), "Measuring Earth-to-Space Contrast Transmittance from Ground Stations," *Appl. Opt.* **12**, 1317 – 1323.
- List, R. J. (1966), *Smithsonian Meteorological Tables*, 6th Revised Ed., Smithsonian Miscellaneous Collections, Vol. 114, Smithsonian Institution, Washington, D. C.
- Middleton, W.E.K. (1952), "Vision Through the Atmosphere," University of Toronto Press, Chapter 10.
- USNAF TP-133, U.S. Naval Avionics Facility (1962), "Handbook, Operation and Service Instructions Aerograph Sets AN/AMQ-17 and AN/AMQ-18," Indianapolis 18, Indiana.
- U.S. Standard Atmosphere (1962), U.S. Government Printing Office, Washington, D.C. 20402.
- U.S. Standard Atmosphere Supplements (1966), U.S. Government Printing Office, Washington, D.C. 20402.