

**HYDROLIGHT 5  
ECOLIGHT 5  
USERS' GUIDE**

**Curtis D. Mobley  
Lydia K. Sundman**

**Sequoia Scientific, Inc.  
2700 Richards Road, Suite 107  
Bellevue, WA 98005**

**First Printing, December 2008**

## **Copyright**

HydroLight is copyright ©1992 and EcoLight is copyright ©2008 by Curtis D. Mobley. All rights reserved worldwide. This Users' Guide is protected by federal copyright law. No part of this document may be copied or distributed, transmitted, transcribed, stored in a retrieval system, or translated into any human or computer language, in any form or by any means (electronic, mechanical, magnetic, manual, or otherwise), except by prior written permission of Curtis D. Mobley. However, licensees of HydroLight and EcoLight are given limited permission to reproduce this document provided such copies are for their use only and are not sold or distributed to third parties. All such copies must contain the title page and this notice page in their entirety.

## **Trademarks**

Microsoft, MS-DOS, Visual Basic, Excel, Windows are registered trademarks of Microsoft Corporation. Lahey is a registered trademark of Lahey Computer Systems, Inc. IDL is a registered trademark of ITT Visual Information Solutions, Inc. All other brand names are trademarks of their respective holders.

## **Disclaimer**

Curtis D. Mobley and Sequoia Scientific, Inc. reserve the right to revise the HydroLight and EcoLight software, Users' Guide, Technical Documentation, or other publications and products with no obligation to notify any person or any organization of such revision. In no case shall Curtis D. Mobley or Sequoia Scientific, Inc. be liable for any loss of profit or any other commercial damage, including but not limited to special, consequential, or other damages.

## **Acknowledgment**

Dr. Marcos Montes of the U.S. Naval Research Laboratory provided invaluable assistance in extending the RADTRAN sky irradiance model to 300 and 1000 nm. He has also assisted with beta testing and developed several internal changes to the core code, which have improved its numerical efficiency and accuracy. Eric Rehm also performed very useful beta testing of the EcoLight code.

## Technical Support

Technical support for HydroLight and EcoLight can be obtained in accordance with the user's license agreement from

Curtis D. Mobley  
425-641-0944 ext 109  
fax: 425-643-0595  
curtis.mobley@sequoiasci.com

Lydia K. Sundman  
lsundman@sequoiasci.com

If you encounter a problem during a HydroLight or EcoLight run, please e-mail us the following:

- The "Licensed to" name and Serial Number of the copy you are running. These are found on the opening form of the User Interface, and at the top of the printout.
- A description of the problem, error messages, or other pertinent information.
- The input file (the `Iroot.txt` file for the run, which is found in the `HE5\run\batch` directory)
- The printout file (the `Prout.txt` file, from either the `HE5\output\Hydrolight` or `HE5\output\Ecolight` directories)
- Any user-supplied input data files used by the run.
- If your run included a user-defined IOP model or function, or if you included bioluminescence, please also send us the `root.for` file from the `HE5\code\batch` directory and any user-defined subroutines we would need to repeat the run.

This information will greatly increase the speed at which we can troubleshoot the problem.

## HydroLight Users' Group

HydroLight licensees are encouraged to join the HydroLight Users' Group at <http://tech.groups.yahoo.com/group/HydroLightUsers/>. This web site is used to make announcements about HydroLight, distribute detailed technical notes about HydroLight algorithms, post bug fixes, share new code written by users, and for general communication between HydroLight users. A file of FAQs is maintained there.

## TABLE OF CONTENTS

1. INTRODUCTION.....	1
1.1 Philosophical Comments, Warnings, and Excuses.....	3
2. INSTALLING HE5.....	6
2.1 Computer Requirements.....	6
2.2 Installation on Microsoft Windows Operating Systems.....	7
2.3 Uninstalling HE5.....	8
3. OVERVIEW OF HE5.....	9
3.1 Ways in Which HE5 Can Be Used.....	9
3.2 The Physical Mode.....	10
3.3 The HydroLight Mathematical Model.....	12
3.4 The HydroLight Coordinate System.....	14
3.5 The EcoLight Mathematical Model.....	17
3.6 Input.....	18
3.7 Output.....	20
4. HE5 ORGANIZATION.....	22
4.1 The HE5 Software Package.....	22
4.2 File Naming Conventions.....	24
4.3 Directory Structure.....	27
5. THE GRAPHICAL USER INTERFACE.....	35
5.1 Run Initialization.....	37
5.2 IOP Specification.....	38
5.3 Inelastic Scattering and Bioluminescence.....	35
5.4 Wavelength Specification.....	46
5.5 The Air-Water Interface and Sky.....	49
5.6 The Bottom Boundary Condition.....	52
5.7 Output Depth Options.....	52
5.8 Output and Run Options.....	54
6. EXAMPLE HE5 RUNS.....	57
6.1 Example 1: A Simple Radiative Transfer Simulation.....	57
6.2 Example 2: A Simulation of a Case 1 Water with the Classic IOP Model.....	62
6.3 Example 3: A Simulation of a Case 1 Water with a New IOP Model.....	66
6.4 Example 4: A Simulation of Case 2 Water.....	67

7. OUTPUT FROM STANDARD RUNS. ....	80
7.1 The Default Printout. ....	80
7.2 Examining Output with EXCEL. ....	84
7.3 Plotting Output with IDL.....	87
8. ADVICE ON USING HE5. ....	89
8.1 Depth Considerations.....	89
8.2 Wavelength Considerations.....	91
8.3 Inelastic Scattering and Bioluminescence.....	93
8.4 Setting Defaults. ....	94
8.5 Making Special Runs.....	94
9. REFERENCES. ....	96
APPENDIX A. LICENSE AGREEMENT FOR USE OF HydroLight and EcoLight Version 5.....	97

# 1. INTRODUCTION

This Users' Guide is intended for new users of the HydroLight-EcoLight Version 5 software package. This guide explains how to install the software, gives a general overview of HydroLight and EcoLight, and shows how to make standard runs and examine the output. The Users' Guide is independent of any other publication and should be adequate for users who wish to run the software as a "black box" model. The Users' Guide assumes that the reader is familiar with the basic terminology and notation of optical oceanography. If this is not the case, then the reader should first consult the review paper by Mobley (1995) or one of the books by Kirk (1994); Spinrad, Carder, and Perry (1994); or Mobley (1994).

The separate Technical Documentation provides additional detailed information and references for the IOP models, sky models, default data sets, etc. available in the version 5 software. The formats for input and output data files are also given there. The text *Light and Water: Radiative Transfer in Natural Waters* (L&W; Mobley, 1994) describes in considerable detail the mathematical methods employed in HydroLight. That book is the primary technical documentation for the HydroLight numerical model. The source code itself is documented by references to the equations in *Light and Water*. That text is now out of print, but the book is available on CD at no charge and is distributed with the HE5 software.

General knowledge of the radiance distribution within and leaving a water body is a prerequisite for the solution of many problems in underwater visibility, ocean color remote sensing, biological primary productivity, and mixed-layer thermodynamics. Moreover, because radiance is the fundamental radiometric quantity, all other quantities of interest to optical oceanographers—various irradiances, diffuse attenuation functions, reflectances and the like—can be computed from their definitions once the radiance is known.

HydroLight and EcoLight are radiative transfer numerical models that compute radiance distributions and derived quantities for natural water bodies. In brief, these models solve the time-independent, unpolarized radiative transfer equation to obtain the radiance distribution within and leaving any plane-parallel water body. Input to the models consists of the absorbing and scattering properties of the water body, the nature of the wind-blown sea surface, the reflectance properties of the bottom of the water column, and the sun and sky radiance incident on the sea surface. Output consists of archival printout and of files of digital data, from which numerical, graphical or spreadsheet analyses can be performed.

The models are designed to solve a wide range of problems in optical oceanography and limnology. The input absorbing and scattering properties of the water body can vary arbitrarily with depth and wavelength. These inherent optical properties (IOPs) can be obtained from actual measurements or from analytical bio-geo-optical models. Analytical models of the IOPs can build up the total IOPs from contributions by any number of individual components such as water, phytoplankton, and mineral particles. The input sky radiance distribution can be completely arbitrary in the directional and wavelength distribution of the direct solar and diffuse sky light. In its most general solution mode, HydroLight and EcoLight include the effects of inelastic scatter by chlorophyll fluorescence, by colored dissolved organic matter (CDOM) fluorescence, and by Raman scattering by the water itself. The models also can simulate internal layers of bioluminescing microorganisms.

HydroLight and EcoLight solve different versions of the radiative transfer equation, but their input and much of their output is the same. However, the models are intended for different applications and their run times differ by factors of tens to hundreds. In this Users' Guide, HydroLight-EcoLight version 5 will be called HE5 when referring to common features of the codes. Differences in HydroLight and EcoLight will be noted as necessary, in which case the individual names will be used.

The HE5 source code is written entirely in FORTRAN (mostly FORTRAN 77 with a few bits of FORTRAN 95), in order to make it easily portable to almost any computer with a FORTRAN 95 compiler<sup>1</sup>. The Lahey FORTRAN 95 Express compiler for Microsoft® Windows® is distributed with the HE5 license. (The compiler must be installed before HE5 can run on a Windows PC.) All input and output files are written as ASCII files, to insure easy transfer of files between computers with different operating systems. In order to simplify running HE5, a “front-end” program is provided for running HE5 in its standard mode (the usual way of running HE5, which will account for the vast majority of runs made by most users). The front end is a graphical User Interface (UI) that runs *only* on computers

---

1. Although it is popular to deride FORTRAN as an ancient language no longer spoken in computer science departments, the fact remains that FORTRAN always has been, is now, and likely will remain the best language for doing serious numerical computations such as solving differential equations—which is what HydroLight does for 90% of its run time. We make no apology for keeping HE5 in FORTRAN. Curt does, however, promise that he will update the code to FORTRAN 95 as soon as he retires.

running some version of the Microsoft Windows operating systems.

The UI front end program is provided to make HE5 user friendly; it is not actually necessary to run the front-end program in order to run HE5 itself. As with previous versions, users can create or modify the needed input files with a text editor and then submit HE5 runs from a command window. This procedure must be used to run HE5 on UNIX or Linux systems. However users are cautioned that manual modification of the input files is tricky due to the complexity of the input, and is thus not recommended. However, this independence of HE5 from the front-end program makes it possible to couple HydroLight or EcoLight with other models, as for example in coupled biological-optical-physical ecosystem models.

Throughout this report, the names of mathematical variables are written in italics, e.g., *U*, *z*, or *zeta*. The names of computer programs, directories, and files are written in a sans serif font, e.g., `abcase1.f` or `Pupcast2.txt`. Path names are written using the DOS format with a backstroke, e.g., `..\HE5\data\phasefun\avgpart.dpf`. User input to and output from programs is show in `Courier`. Options on graphical User Interfaces are shown in `SMALL CAPS`.

Some of the figures in this Users' Guide were generated in color but printed in black and white. The color figures can be seen on the pdf version of the Users' Guide, which is found in the `HE5\documents` directory.

## 1.1 Philosophical Comments, Warnings, and Excuses

**It is important to understand that the HE5 models per se are radiative transfer models, not models of oceanic optical properties. You, the user, must supply the inherent optical properties and boundary conditions to the HE5 core code.** (Indeed, the HE5 model is not even restricted to the oceanic setting, although that is our interest here. If you supply HE5 with the optical properties of orange paint, for example, HE5 will happily solve for the radiance distribution within and leaving the paint.) This requirement for user input gives HE5 great power—it can simulate any water body and each user can run the model for exactly the conditions of interest—but also requires considerable forethought and effort on the user's part, in order to specify IOPs and boundary conditions that correctly describe the water body of interest. Some users of previous versions have not understood their role in providing input to HE5, so let us say the following for emphasis:



HE5 does not know the inherent optical properties, or the chlorophyll profile, or the depth, or anything else about the water body *you* are interested in. *You* must provide this information to HE5. The various IOP models, phase functions, chlorophyll data sets, ac-9 data sets, etc. that come with HE5 are *examples* of how to provide IOP and other information to HE5. *You* will need to replace these example routines and data sets with your own, in order to simulate the water body of interest to you. Garbage in, garbage out.

HE5 computes the radiance and other output (for a given set of input) more accurately than can be measured with standard instrumentation. However, as with any model, HE5's output is only as good as the input provided by the user. If you are using a simple "Case 1" bio-optical model for the absorption and scattering coefficients, guessing the phase function, and using the mid-ocean atmospheric parameters in the sky radiance model, you should not be surprised (and are not allowed to complain) if the HE5-predicted water-leaving radiances differ significantly from what you measured in your experiment in Case 2 coastal waters. Likewise, if you give HE5 a file with thousands of ac-9 data points generated by sampling at 6 Hz during a depth profile, HE5 will do its best to solve the radiative transfer equation with *exactly* the absorption and scattering profile you have given it. The result may be numerically disastrous if the ac-9 profile looks like random instrumental noise superimposed on a smoother signal, as illustrated in Fig. 1. ***It is your job to clean up noisy data, smoothing and massaging as much as your conscience and scientific expertise allow, before using it as input to HE5.***

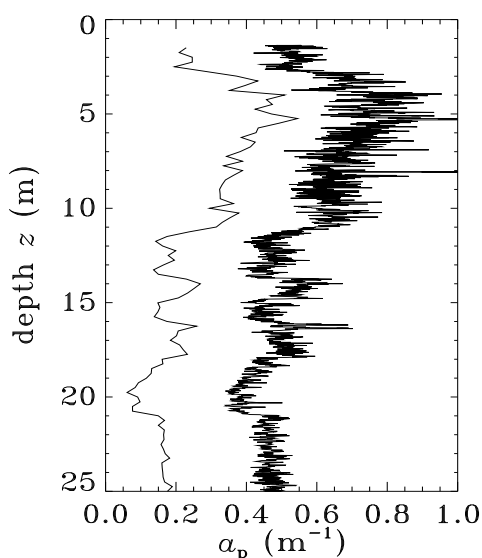

Figure 1. Smoothed and unsmoothed data. The right curve is 2,056 values of particulate absorption  $a_p$  obtained from an ac-9; this curve is too noisy to be used as input to HE5. The left curve (offset to the left by 0.3 for clarity) is the same data binned into 25 cm depth bins to give 95  $a_p$  values; this curve is suitable for input to HE5 and still contains adequate depth resolution of the absorption fine structure.

HE5 does some checking for bad input, but there is still great opportunity for entering incorrect or unphysical input and getting incorrect output.

HE5 has been a work in progress since Curtis Mobley first started working out the numerical algorithms as a postdoc (with Rudolph Preisendorfer) in 1979, and it will continue to be so. The first publically released version of HydroLight was version 3, which ran only on a mainframe computer or UNIX workstation. Version 4 was created in response to users' requests for a more user-friendly code with additional options, and for a code that would run on inexpensive personal computers. Version 5 continues this development. Major modifications were made to the version 4 code to improve its internal numerical algorithms and to add various features requested by users. Version 5 therefore represents a substantial improvement over version 4. Although the invariant imbedding algorithms at the core of HE5 are mature and well debugged after many years of use in previous versions of HydroLight, some core code and options in the graphical User Interface (UI) are new with version 5. The version 5 release therefore may evolve quickly as feedback is received from the users of version 5.

Most notably, software version 5 includes EcoLight, a fast version of HydroLight that solves the azimuthally-averaged radiative transfer equation. EcoLight can be used when all the user wants to know is the nadir-viewing remote-sensed reflectance, irradiances, diffuse attenuation functions, or other quantities that are obtained from an azimuthal integration over the full radiance distribution. Because of the inclusion of EcoLight, the directory structure of HE5 5 is significantly different that in versions 4. HE5 5 also supports runs from 300 to 1000 nm with extended IOP and atmospheric data files.

Although the source code is still provided for both HydroLight and EcoLight, executable files are also provided. These executables can handle most situations of interest. The code will recompile between runs only when required, for example if the user modifies a routine, adds a user-defined IOP model or concentration function, or if bioluminescence is included in the run.

To avoid the considerable expense required in supporting various compilers, the Lahey Fortran 95 Express compiler (LF95 Express) is provided with each HE5 license. LF95 Express is a fully optimizing Fortran 77/90/95 compiler. HE5 is designed to run with LF95 Express (although the core code remains mostly Fortran 77). Licenced users of HE5 are eligible to register their copy with Lahey and obtain support directly from Lahey for the LF95 Express product, just as if the compiler had been licensed directly from Lahey (see [www.lahey.com](http://www.lahey.com)). Note that the LF95 Express license activation lets the compiler be installed on only two computers. HE5 can then be run on the same two computers.

## 2. INSTALLING HE5

This Section describes how to install the HE5 code on a Windows-based personal computer.

### 2.1 Computer Requirements

The HE5 source code is written entirely in standard FORTRAN in order to make the code as portable as possible. Although the core code of HE5 can run on a wide range of computers, *Version 5 is supported only on PCs running the Microsoft Windows 98 or later operating systems* due to the complexity of the new input and subsequent dependence on the UI to set up runs. A PC-Windows platform for HE5 is also strongly recommended for several reasons:

- The HE5 User Interface is written in Visual Basic and therefore runs only on computers with the Microsoft Windows operating system.
- The HE5 software system is designed for the Lahey FORTRAN 95 Express compiler for Microsoft Windows operating systems.
- EXCEL spreadsheet software is usually found on PCs with Windows.
- Related software, such as the IDL graphics package, is much less expensive for PCs than for mainframes or UNIX workstations.

The HE5 package of source code and data files requires about 300 Mbytes of hard-drive storage as distributed. The Lahey compiler requires additional memory. After compilation on the user's computer, the executable file for the main code is approximately one Mbyte. The minimum required amount of random access memory (RAM) is not large. Modern PCs have 250 Mbytes or more of RAM, which is sufficient for satisfactory compilation and running of HE5. The digital output files can be 10 Mbytes or larger for runs requesting output at many depths and wavelengths. Thus, disk storage can be consumed quickly in a series of simulations requesting extensive output (e.g. for high-resolution graphics). Moreover, some of the internal scratch files used during the solution of the radiative transfer equation can be many tens of Mbytes if many depths and wavelengths are included in the run. Again, most PCs now have tens to hundreds of Gigabytes of hard drive space, which is more than sufficient.

The UI is designed for optimum use on monitors with 1024 x 768 pixels. Lower-resolution monitors cause some of the UI forms to display as larger than the monitor screen. Higher-resolution monitors make the UI forms appear smaller than intended, which makes the forms harder to read.

The UI front-end program issues commands to invoke the compiler and linker if necessary. In Version 5, the code was rewritten so that only runs that involve user-modifications to the code or call user-defined subroutines require the code to recompile between runs. This includes runs that use a user-defined IOP model, specify component concentrations with function calls, or include bioluminescence via user-defined routines. For these cases, the file `lroot.for` is written by the UI into the `HE5\code\batch` directory and is necessary to completely specify the run.

The commands necessary for invoking the compiler are different for different brands of compilers, and even for different versions of the same compiler. *Because the Lahey compiler is provided with HE5, no support is given for other FORTRAN compilers.*

## 2.2 Installation on Microsoft Windows Operating Systems

This section describes how to install HE5 on a PC running the Microsoft Windows operating system. It is assumed that you will be running HE5 with the Lahey LF95 Express compiler that comes with HE5.

Installing HE5 is a two-step process: first, install the LF95 compiler using its CD, then install HE5 using its CD. HE5 will not run if the LF95 compiler is not installed (this refers only to standard runs made using the graphical user interface on a PC with Windows).

The HE5 software package is distributed on a CD as one (uncompressed) directory named `HE5` (with subdirectories as seen in Fig. 6). To install the code on your PC, do the following:

**Step 1.** Install the Lahey LF95 Express compiler in accordance with the installation instructions provided with that software. **You will need to enter the serial number given on the CD case in order to activate the license. This activation requires an internet connection.** (If your computer is not on the internet, contact Lahey via another computer to obtain a license file, which you can then move onto the computer where HE5 is to be run.) We encourage you to register your copy of LF95 with Lahey, which gives you full user support from Lahey, just as if you had licensed the compiler directly from them.

**Note that the Lahey LF95 Express compiler allows itself to be installed on only TWO computers. HE5 can then be installed and run on the same two computers.**

**Step 2.** Insert the HE5 CD into its drive. The installation program should start automatically. If it does not, go to START → RUN and run `setup.exe` from the CD (e.g., if the CD is in drive D you would type `d:\setup.exe` at the run prompt).

**Step 3.** You will be asked to select the folder/directory (e.g., C:\ or C:\Program Files) into which HE5 will be installed. A new folder HE5 will be created and placed in the folder you selected (*unless* you select an *existing* folder named HE5, in which case the existing HE5 folder will be overwritten). You will also be asked to read and accept the license agreement. The installer takes care of all aspects of the installation including: copying the files, updating and registering any system files needed by HE5, removing the read-only flags from the HE5 files, and creating shortcuts for HE5 in both the START → PROGRAMS window and on the desktop.

### 2.3 Uninstalling HE5

You may on occasion need to uninstall HE5, for example when moving the code from an old computer to a new one. Also, if you need to reinstall HE5 for some reason, you should first uninstall the old version. Because the installation software updates the Windows registry files when HE5 is installed, it is important to uninstall the code properly. This is done as follows:

go to MY COMPUTER → CONTROL PANEL → ADD/REMOVE PROGRAMS

select HE5 and click on ADD/REMOVE

follow the directions to remove all (system) files associated with HE5

This operation will remove certain system files, the executable file for the UI (file HE5\frontend\HE5WinFE.exe), and update the registry, but it will leave the HE5 icon on the desktop. More importantly, the HE5 directory and all of its contents (including output from previous runs) will be left intact. You can remove the HE5 directory and all of its contents by opening WINDOWS EXPLORER, clicking in the HE5 directory, clicking on DELETE, and following the instructions to delete everything. Be sure you have saved any needed output from previous HE5 runs before deleting the HE5 directory! Finally, the HE5 icon can be dragged from the desktop to the trash bin. Removal of the LF95 Express compiler must be performed as a separate software removal.

### 3. OVERVIEW OF HE5

This section gives brief descriptions for new users of how HE5 can be used, of what assumptions are built into the code, of what input is required, and of what output can be obtained from a HE5 run.

#### 3.1 Ways in Which HE5 Can Be Used

Previous versions of HydroLight have been used in a wide variety of studies ranging from bio-optical oceanography to remote sensing. Some of the ways in which HE5 can be used are as follows:

- HE5 can be run with modeled input values to generate in-water light fields, which in turn become the input to models of primary productivity or mixed-layer thermodynamics. Such information is fundamental to the coupling of physical, biological, and optical feedback models.
- HE5 can be run with the IOPs of different water types to simulate in-water light fields for the purpose of selecting or designing instruments for use in various water types. Such information can aid in the planning of field experiments.
- HE5 can be run with assumed water inherent optical properties as input, in order to obtain estimates of the signals that would be received by various types or configurations of remote sensors, when flown over different water bodies and under different environmental conditions. Such information can guide the planning of specific operations.
- HE5 can be used to isolate and remove unwanted contributions to remotely sensed signatures. Consider the common remote-sensing problem of extracting information about a water body from a downward-looking imaging spectrometer. The detected radiance contains both the water-leaving radiance (the signal, which contains information about the water body itself) and sky radiance reflected upward by the sea surface (the noise). HE5 separately computes each of these contributions to the radiance heading upward from the sea surface and thus provides the information necessary to correct the detected signature for surface reflection effects.

- When analyzing experimental data, HE5 can be run repeatedly with different water optical properties and boundary conditions to see how particular features of the data are related to various physical processes or features in the water body (such as substance concentrations or external environmental conditions). Such simulations can be valuable in formulating hypotheses about the causes of various features in the data.
- HE5 can be used to simulate optical signatures for the purpose of evaluating proposed remote-sensing algorithms for their applicability to different environments or for examining the sensitivity of algorithms to simulated noise in the signature.
- HE5 can be used to characterize the background environment in an image. When attempting to extract information about an object in the scene, all of the radiance from the natural environment may be considered noise, with the radiance from the object being the signal. The model can then be used to compute and remove the environmental contribution to the image.
- HE5 can be run with historical (climatological) or modeled input data to provide estimates about the marine optical environment during times when remotely or in-situ sensed data are not available.

Such information can be provided in many forms: water-leaving radiances for remote-sensing applications, in-water apparent optical properties (such as  $K$  functions) for Lidar bathymetry applications, or ambient light field data as may be relevant to biological productivity or underwater visibility applications.

### **3.2 The Physical Model**

Many problems of interest in optical oceanography and remote sensing can be solved using time-independent radiative transfer theory applied to plane-parallel geometries. The consideration of time-independent, plane-parallel problems is not as restrictive as it might seem on first glance. For example, although the oceans are horizontally inhomogeneous, the horizontal scales of significant optical variability (typically tens of meters to kilometers) are usually much greater than the vertical scales (centimeters to tens of meters). In this case we can think of the ocean as consisting of optically independent "patches" of water, for which

each patch can be well modeled as a horizontally homogeneous water body whose optical properties vary only with depth. (This is a one-dimensional geometry, with the one dimension being depth). We can then independently apply a one-dimensional radiative transfer model at the center of each patch in order to simulate the entire, horizontally inhomogeneous water body. In the analysis of imaging spectrometer data, one sometimes might even apply such a model to the water patch associated with each pixel in the image.

Such a piecewise simulation is justified so long as the horizontal size of each water patch is at least several photon mean free paths. This is usually the case. In the open ocean, photon mean free paths (the inverse of the beam attenuation coefficient) are never more than 50 m (at blue wavelengths, and much less at other wavelengths) in even the clearest waters; horizontal variability in such waters is often on scales of kilometers. In coastal waters subject to river runoff, sediment resuspension, and variable shallow bottom topography, optical properties and boundary conditions can change horizontally on scales of meters to tens of meters. However, such waters tend to be rather turbid and have photon mean free paths of tens of centimeters to a few meters. In either case, the use of a one-dimensional radiative transfer model is justified. The use of time-independent radiative transfer is valid whenever the time scales for changes in environmental conditions (typically seconds to seasons) are much greater than the time required for the light field to assume a steady state within the water body after a change in the optical properties or boundary conditions (milliseconds). Solving a sequence of time-independent, one-dimension radiative transfer problems in order to simulate a changing (in both time and space) water body is computationally much faster than solving one large time-dependent, three-dimensional problem.

Other physical considerations also dictate the generality required in an oceanic radiative transfer model. High absorption by water itself means that little light penetrates the ocean outside of the near-ultraviolet to near-infrared region from 300 to 750 nm. The presence of phytoplankton, absorbing minerals, or dissolved substances can greatly limit light penetration below 400 nm. For the purpose of computing energy transfer through the air-water surface, it is often sufficient to account for the sea surface slope statistics while ignoring the surface height statistics. Multiple scattering is almost always important, but polarization may be neglected for many applications. Inelastic scattering processes such as Raman scatter by the water itself and fluorescence by chlorophyll and CDOM can in some circumstances make significant contributions to the light field.

The HE5 physical model, which addresses the above considerations, can be summarized as follows:



- time-independent
- horizontally homogeneous IOPs and boundary conditions
- arbitrary depth dependence of IOPs
- wavelengths between 300 and 1000 nm
- Cox-Munk capillary-gravity wave sea-surface slope statistics
- finite or infinitely deep (non-Lambertian) water-column bottom
- includes all orders of multiple scattering
- can optionally include Raman scatter by water
- can optionally include fluorescence by chlorophyll and CDOM
- can optionally include horizontally homogeneous internal sources such as bioluminescing layers
- does not include polarization
- does not include sea surface elevation statistics (wave shadowing)
- does not include whitecaps

### 3.3 The HydroLight Mathematical Model

The fundamental quantity that describes the time-independent, one-dimensional (depth-dependent) light field in the ocean is the spectral radiance  $L(z, \theta, \varphi, \lambda)$ , with units of  $\text{W m}^{-2} \text{sr}^{-1} \text{nm}^{-1}$ . The spectral radiance completely determines the depth ( $z$ ), directional ( $\theta, \varphi$ ), and wavelength ( $\lambda$ ) behavior of the light field. Therefore, all other quantities of interest, such as various irradiances, diffuse attenuation functions ( $K$ -functions), and reflectances, can be computed from their definitions once the spectral radiance is known. In order to predict the spectral radiance, HydroLight solves the integro-differential radiative transfer equation (RTE) along with its boundary conditions. Because of their mathematical complexity, these equations must be solved numerically for any realistic situation (see Chapter 8 of *Light and Water*).

Any radiance sensor actually measures an average of  $L(z, \theta, \varphi, \lambda)$  taken over some finite solid angle  $\Delta\Omega$ , which is determined by the field of view of the instrument, and over some finite bandwidth  $\Delta\lambda$ , which is determined by the wavelength response of the instrument. Likewise, in order to solve the RTE numerically, we discretize it by averaging over direction and wavelength. In the HE5 model, this directional averaging is performed by first partitioning the set of all directions  $(\theta, \varphi)$ ,  $0 \leq \theta \leq 180^\circ$ ,  $0 \leq \varphi < 360^\circ$ , into regions bounded by lines of constant  $\theta$  and constant  $\varphi$ , plus two polar caps. These quadrilateral regions and polar caps are collectively called "quads." The individual quads  $Q_{uv}$  are labeled by discrete indices  $u = 1, 2, \dots, M$  and  $v = 1, 2, \dots, N$  to show their  $\theta$  and  $\varphi$  positions, respectively. The standard (default)

quad layout is shown in Figure 2. In this layout, which has  $M = 20$  and  $N = 24$ , the polar caps have a  $5^\circ$  half angle and the  $\theta$  boundaries lie at  $5, 15, 25, \dots, 75, 85, 90, 95, 105, \dots, 175$  degrees. For mathematical reasons there is no quad centered on the “equator” at  $\theta = 90^\circ$ . However, the radiances computed for the  $85^\circ$ - $90^\circ$  and  $90^\circ$ - $95^\circ$  quads can be averaged to give the “horizontal” radiance at a nominal angle of  $\theta = 90^\circ$ . Thus the HydroLight standard quad layout essentially gives  $10^\circ$  resolution in  $\theta$  and  $15^\circ$  in  $\phi$ .

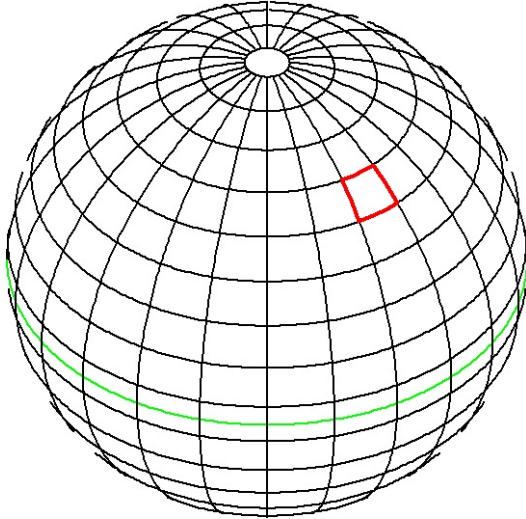

Figure 2. The HydroLight standard quad layout, which has a nominal angular resolution of  $\Delta\theta = 10^\circ$  and  $\Delta\phi = 15^\circ$ . The red box indicates a particular  $10^\circ \times 15^\circ$  quad. The green line is the “equator” between the upper and lower hemispheres of directions.

Similarly, the wavelength region of interest is partitioned into a number of contiguous wavelength bands of width  $\Delta\lambda_j, j = 1, 2, \dots, J$ . The  $\Delta\lambda_j$  need not be the same size for different  $j$  values.

The fundamental quantities computed by HydroLight are then the quad- and band-averaged radiances at any selected set of depths  $z_k, k = 1, 2, \dots, K$ :

$$L(k, u, v, j) \equiv \frac{1}{\Delta\Omega_{uv} \Delta\lambda_j} \int_{\Omega_{uv}} \int_{\Delta\lambda_j} L(z_k, \theta, \phi, \lambda) \sin\theta \, d\theta \, d\phi \, d\lambda .$$

In addition to the radiances within the water, HydroLight computes the upwelling radiance in all directions (all quads) just *above* the sea surface. This upwelling radiance includes both the water-leaving radiance and that part of the incident direct and diffuse sky radiance that is reflected upward by the wind-blown sea surface. The water-leaving and reflected-sky radiances are computed separately in order to isolate the water-leaving radiance, which is the quantity of interest in many remote sensing applications. The development of the quad- and

band-averaged versions of the RTE and of the associated boundary conditions is given in full in *Light and Water*.

It must be noted that the quads “homogenize” the radiance within each quad, much like a frosted-glass window does. Thus, in the quad layout of Fig. 2, it is not possible to resolve the difference in the radiance for polar angles  $\theta = 26^\circ$  and  $\theta = 34^\circ$ , because they both lie in the same quad extending from  $\theta = 25^\circ$  and  $\theta = 35^\circ$ . However, there is a difference in  $\theta = 34^\circ$  and  $\theta = 36^\circ$ , because those angles lie in different quads and thus are represented by different quad-averaged radiances. If it is necessary to have greater angular resolution in the radiance distribution, a different quad layout can be created (with considerable effort; see the Technical Documentation). Note, however, that the computer storage and run time are proportional to the square of the number of quads, so increasing the angular resolution comes with a considerable computational cost. Increasing the quad resolution beyond the standard quad partition shown in Fig. 2 will not significantly improve the accuracy of the computed irradiances and other quantities of general interest and is therefore not recommended.

### 3.4 The HydroLight Coordinate System

HydroLight uses an x-y-z cartesian coordinate system with +x in the downwind direction and +z downward. Directions are specified via the polar angle  $\theta$  and azimuthal angle  $\varphi$ , with  $\theta = 0$  being straight down and  $\varphi = 0$  being downwind. In radiative transfer theory, direction  $(\theta, \varphi)$  always refers to the direction the photons are traveling; the corresponding radiance is  $L(\theta, \varphi)$ . Experimentalists, however, like to use  $(\theta, \varphi)$  to denote the direction they are pointing their radiometer. The radiance measured by a radiometer pointing in direction  $(\theta, \varphi)$  is  $L(180-\theta, 180+\varphi)$ . Depending on which convention we choose for HydroLight output, either the theoreticians or the experimentalists will be unhappy.

In the HydroLight printout, we adopt the following convention, which is illustrated in Fig. 3. Polar angle  $\theta$  is measured either from the nadir direction (the +z direction) or from the zenith direction (the -z direction), for instruments pointing downward or upward, respectively. When the instrument is pointing downward, we add a subscript “u” for “upward” to the radiance to remind us that we are referring to the upwelling radiance, i.e., to photons traveling upward. When the instrument is pointing upward, we add a subscript “d” to the radiance to remind us that we are referring to downwelling radiance, i.e., to photons traveling downward. Thus the theoreticians' radiance  $L(\theta, \varphi)$  is denoted  $L_d(\theta, \varphi)$  in the printout, and the theoreticians' radiance  $L(180-\theta, 180+\varphi)$  is denoted  $L_u(\theta, \varphi)$ . This *u, d* subscript convention is commonly used in optical oceanography.

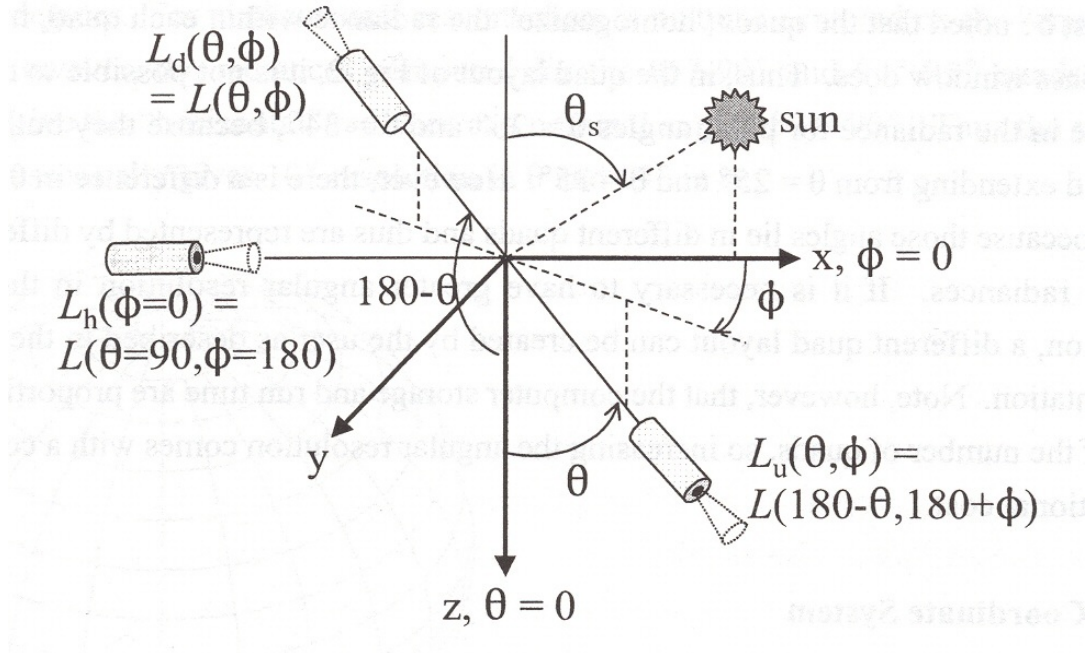

Fig 3. Coordinate system and notation conventions for radiance as used in HydroLight printout.

For example,  $E_d$  denotes the downwelling plane irradiance, which is measured by a cosine collector pointing upward. Likewise, in the printout, the horizontal radiance of photons traveling in the  $(\theta=90, \phi=180)$  direction is denoted by  $L_h(\phi=0)$ .

In the printout, a depth of  $z = 0$  denotes a position within the water, just beneath the mean sea surface. A depth of  $z = a$  or “in air” denotes a position in the air, just above the mean sea surface. Thus the radiance  $L_u(z=0, \theta, \phi)$  denotes the upwelling radiance just beneath the sea surface, and  $L_u(z=a, \theta, \phi)$  denotes the *total* upwelling radiance in the air. The total upwelling radiance in the air is the sum of the water-leaving radiance,  $L_w(\theta, \phi)$ , plus the downwelling sky and sun radiance that is reflected upward by the sea surface itself (the sun glint),  $L_{refl}(\theta, \phi)$ . The sky radiance seen when looking in the  $(\theta, \phi)$  direction is  $L_{sky}(\theta, \phi)$ . These quantities are illustrated in Fig. 4.

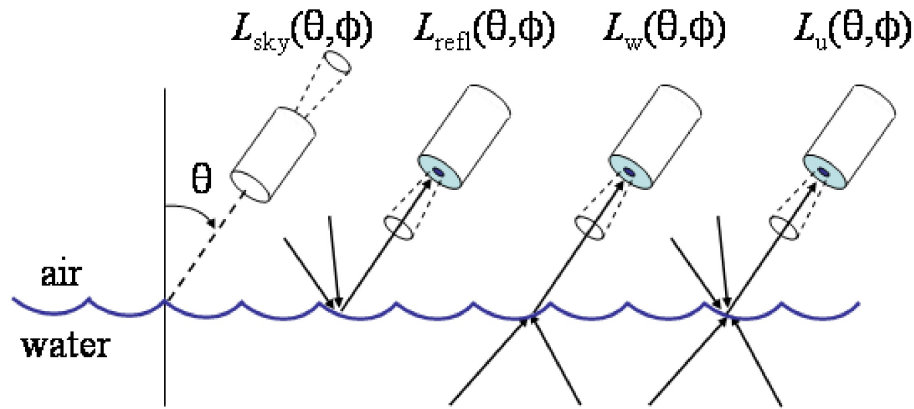

Fig. 4. Illustration of the various radiances just above the sea surface.

The standard version of HydroLight uses azimuthally averaged sea-surface wave-slope statistics, in which case the azimuthal angle of the sun relative to the downwind direction,  $\phi_s$ , is irrelevant, and  $\phi_s$  is set to 0, as shown in Fig. 3. The sun's polar angle  $\theta_s$  is always measured from the zenith, as is customary. Thus the sun's radiance is then  $L_a(z=a, \theta_s, \phi=0) = L_{sky}(\theta_s, \phi=0)$ .

It should be kept in mind that any radiance labeled for convenience by exact depth, direction, and wavelength values  $(z, \theta, \phi, \lambda)$  represents the radiance at the exact depth  $z$  (not a value averaged over a finite depth interval), but which is directionally averaged over the quad containing direction  $(\theta, \phi)$  and which is wavelength averaged over the wavelength band containing the nominal wavelength  $\lambda$ . (Radiances computed when selecting the “single wavelength” option can be thought of as being band averaged over a 1 nm wide band.)

**Radiances are thus quad- or band-averaged spectral radiances with units of  $\text{W m}^{-2} \text{sr}^{-1} \text{nm}^{-1}$ , not band-integrated values. Likewise, irradiances are spectral values with units of  $\text{W m}^{-2} \text{nm}^{-1}$ .**

Finally, radiative transfer theory is formulated in terms of energy units, not quanta. In the HE5 output, the spectral scalar irradiance  $E_0(z, \lambda)$  with units of  $\text{W m}^{-2} \text{nm}^{-1}$  is also converted to quanta units of mol photons  $\text{m}^{-2}$  at the very end of the calculations for the convenience of photobiologists, and the corresponding PAR profile is computed. These values are given in the printout file.

### 3.5 The EcoLight Mathematical Model

As just seen, HydroLight solves the RTE to obtain the radiance distribution as a function of depth, polar and azimuthal direction, and wavelength. This is computationally expensive but necessary if you need to know the radiance in different directions, e.g., for underwater visibility applications where directions toward or away from the sun's direction can have greatly differing radiances. However, many applications such as ecosystem modeling require only various irradiances or diffuse attenuation functions, which are obtained by integrating the radiance distribution over all azimuthal angles and over selected polar angles (such as at the upper, lower, or both hemispheres of directions). Likewise, much remote sensing assumes a nadir-viewing direction, in which case no azimuthal angle is involved. In these cases, it is possible to solve an azimuthally averaged version of the RTE to obtain azimuthally averaged radiances, from which the irradiances can be quickly obtain. This is what EcoLight does. Solving the azimuthally averaged RTE requires much less computer time than solving the azimuthally dependent RTE. The tradeoff, of course, is that you do not get the full radiance distribution.

**If your application requires only irradiances, diffuse attenuation functions, the irradiance reflectance, or the nadir-viewing remote-sensing reflectance, then you should run EcoLight.** It should be noted that EcoLight gives the same irradiances, K functions, and polar-cap radiances as does HydroLight (except for very small differences due to the different numerical algorithms). Moreover, both HydroLight and EcoLight require exactly the same inputs for IOPs, and for sky and bottom boundary conditions. Therefore the UI solicits the same inputs for both models. The decision of which model to run is then made on the last form of the UI. Indeed you can run one and then the other without repeating the input, if you wish to compare the results.

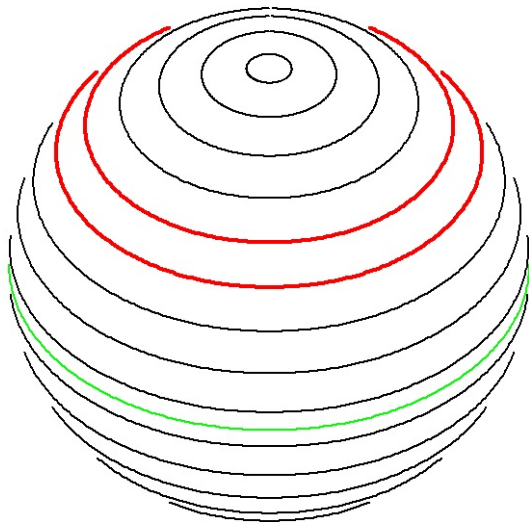

Figure 5. The EcoLight standard band layout, which has a nominal angular resolution of  $\Delta\theta = 10^\circ$  and no  $\varphi$  dependence; compare with the HydroLight quad layout of Fig. 2. The red band indicates a particular  $10^\circ$  polar angle band. The green line is the “equator” between the upper and lower hemispheres of directions.

### 3.6 Input

In order to run HE5 to predict the spectral radiance distribution within and leaving a particular body of water during particular environmental (sky and surface wave) conditions, the user supplies the core models with the following information (via direct input in the UI or via user-written subroutines or user-supplied data files):

- **The inherent optical properties of the water body.** These optical properties are the absorption and scattering coefficients and the scattering phase function (which are equivalent to the volume scattering function, the beam attenuation coefficient, and the albedo of single scattering). These properties must be specified as functions of depth and wavelength.
- **The state of the wind-blown sea surface.** The sea surface is modeled using the Cox-Munk capillary-gravity wave-slope statistics, which adequately describe the optical reflection and transmission properties of the sea surface for moderate wind speeds and solar and viewing angles away from the horizon. Only the wind speed needs to be specified. In Version 5, an option was added to include the dependence of the real index of refraction of the water on wavelength, salinity, and temperature. This is generally not a large effect on the sea-surface reflectance and transmittance properties, but it can be important for some applications, especially near 300 or 1000 nm.
- **The sky spectral radiance distribution.** This radiance distribution (including background sky, clouds, and the sun) can be obtained from semi-empirical models that are built into HE5, from observation, or from a separate user-supplied atmospheric radiative transfer model (such as MODTRAN; Acharya, *et al.*, 1998)). For most applications, the default sky radiance and irradiance models are adequate. In version 5, an option has been added to allow the user to specify the day of the year for very accurate computation of the earth-sun distance, which affects the incident solar irradiance by a few percent over the course of the year.
- **The nature of the bottom boundary.** The bottom boundary is described in terms of a bi-directional reflectance distribution function (BRDF). For finite-depth bottoms, the BRDF is computed from the given irradiance reflectance of the bottom, if the bottom is a Lambertian surface, or from a user-supplied BRDF, which can be non-Lambertian. For

infinitely deep water, the inherent optical properties of the water body below the region of interest are used to compute the needed (non-Lambertian) BRDF that describes the reflectance properties of the water below the region of interest.

The absorption and scattering properties of the water body can be provided to the HE5 model in various ways. For example, if actual measurements of total absorption are available at selected depths  $z$  and wavelengths  $\lambda$ , then these values can be read from a file provided at run time. An interpolation scheme is used to define absorption values for those  $z$  and  $\lambda$  values not contained in the data set. In the absence of actual measurements, the total absorption of the water body can be modeled in terms of contributions by any number of components. Thus the total absorption can be built up as the absorption by water itself, plus the absorption by chlorophyll-bearing microbial particles, plus that by CDOM, by detritus, by mineral particles, and so on. In order to specify the absorption by chlorophyll-bearing particles, for example, you can specify the chlorophyll profile of the water column and then use a bio-optical model to convert the chlorophyll concentration to the needed absorption coefficient. The chlorophyll profile also provides information needed for the computation of chlorophyll fluorescence effects. Each individual absorption component has its own depth and wavelength dependence. Similar modeling can be used for scattering.

Phase function information is often provided by using a Rayleigh-like phase function for scattering by the water itself, by using either a Petzold-like phase function or a phase function selected to have a given backscattering ratio for scattering by particles, and by assuming that dissolved substances like CDOM do not scatter. The individual-component phase functions are weighted by the respective scattering coefficients and summed in order to obtain the total phase function.

HE5 also requires the downwelling radiance incident onto the sea surface as input. The HE5 model does not carry out any radiative transfer calculations for the atmosphere *per se*. However, the sky radiance for either cloud-free or solid overcast skies can be estimated from simple analytical models or from semi-empirical models; such models are provided as a part of the HE5 code. Alternatively, if the sky radiance is actually measured, that data can be used as input to HE5 via a user-written subroutine. It is also possible to run an independent atmospheric radiative transfer model such as MODTRAN in order to generate the sky radiance coming from each quad of the sky hemisphere, and then give the MODTRAN-generated values to HE5 as input.

For finite-depth water columns, the bottom boundary BRDF is usually computed from the specified irradiance reflectance of the bottom and the assumption that the bottom is a



Lambertian reflector. In general, the bottom reflectance is a function of wavelength and depends on the type of bottom—gray mud, ooid sand, sea grass, etc. HE5 contains the spectral reflectances for a number of different bottom types. These can be selected on the UI.

For infinitely deep water columns, the (non-Lambertian) BRDF is automatically computed *using the IOPs at the deepest depth where output is requested* in the simulation at hand. If the run does not include fluorescence, Raman scatter, or bioluminescence, this non-Lambertian bottom boundary conditions is then applied at the greatest user-requested depth. For runs involving inelastic scatter or internal sources, the bottom boundary condition is applied at a deeper depth in order to assure a good solution at the greatest depth requested by the user. See the Technical Documentation §3.3 and HydroLight Technical Note 6 (in the HE5\Documents directory or on the Users' Group website) for a detailed discussion of the bottom boundary conditions when the water in infinitely deep and inelastic scatter is included. For a remote sensing simulation concerned only with the water-leaving radiance, it is usually sufficient to solve the radiative transfer equation only for the upper two “diffuse attenuation depths” [a depth of  $2/K_d(\lambda)$ ], because almost all light leaving the water surface comes from this near-surface region. In this case, the bottom boundary condition can be taken to describe an optically infinitely deep layer of water below the depth corresponding to two diffuse attenuation depths. In a biological study of primary productivity, it might be necessary to solve for the radiance down to five (or more) optical depths, in which case the bottom boundary condition would be applied at that greater depth. In such cases HE5 computes the needed bottom boundary information from the inherent optical properties at the deepest depth of interest.

### 3.7 Output

Output from HE5 consists of both “printout” (an ASCII text file formatted for viewing with a text editor such as WordPad, or for hard-copy printing) and files of digital data. The default printout gives sufficient information to document the input to the run and to show the quantities of interest to most oceanographers (such as various irradiances, reflectances, mean cosines, irradiance  $K$ -functions, and zenith and nadir radiances). The printout is useful for taking a quick look at the results of a run, or for cutting and pasting a particular part of the output into another document or spreadsheet. Optionally, the printout can give the full radiance distribution (separated into direct and diffuse components), radiance  $K$ -functions, elastic-scatter path functions, and the like. The printout is easily tailored to the user's requirements. Section 7.1 describes the printout in more detail.

An optional output file (the **Droot.txt** file) contains the complete input and output from the run including the computational grid; the component IOPs; the full direct and diffuse radiance distributions in air and water as a function of depth, direction, and wavelength; and various irradiances. This file is generally used as input to plotting routines to obtain graphical output of various quantities as functions of depth, direction, or wavelength, such as seen in Fig. 10.

A similar optional output file (the **Lroot.txt** file) contains only the total radiance distribution as a function of depth, direction, and wavelength. This file is useful for “slicing and dicing” the radiance distribution to create plots like those seen in Fig. 11.

Routines for graphical output are not a part of the HE5 code *per se* because of the wide variety of graphics packages in use and because different users generally want different kinds of plots. However, a few plotting routines written in the IDL language are included with HE5 as a convenience for users who have that popular software package. IDL routines are provided to read the **Droot.txt** and **Lroot.txt** output files. Section 7.3 comments further on the use of IDL for plotting HE5 output.

Two other optional output files (the **Sroot.txt** and **Mroot.txt** files) are formatted for use with Microsoft EXCEL<sup>®</sup> spreadsheets. One file is formatted to facilitate the analysis of data one wavelength at a time. For example, you might want to plot various irradiances as a function of depth at one wavelength. The other file is formatted to facilitate the analysis of one variable at a time, as a function of depth and wavelength. For example, you might want to plot the absorption coefficient as a function of depth and wavelength. EXCEL macros are provided to open these files within EXCEL and automatically generate spreadsheets containing the quantities of interest to most oceanographers. Section 7.2 describes how to convert these HE5 output files into EXCEL spreadsheets.

## 4. HE5 ORGANIZATION

This section describes how the HE5 code is organized. The different types of routines and data files are described, and the file-naming conventions and directory structure are established.

### 4.1 The HE5 Software Package

The HE5 software package consists of many different main programs, subroutines, and data files. The different routines and files can be classified as follows:

- **Core FORTRAN main programs and subroutines.** These core routines include both HE5-specific routines and various public-domain subroutines taken from sources such as LAPACK (Linear Algebra PACKage) and BLAS (Basic Linear Algebra Subroutines; see Dongarra and Grosse, 1987). The public-code routines are used by the HE5-specific routines for mathematical tasks such as matrix inversion, eigenvector-eigenvalue analysis, and solving differential equations. Only the most sophisticated users would even contemplate tampering with any of these highly mathematical core routines.
- **Example user-supplied subroutines.** The routines defining the `abconst`, `abcase1`, `abnewcase1`, `abcase2`, etc. IOP models are all examples of a user-supplied absorption and scattering routine. These particular subroutines are provided with the HE5 code and can be used as is, or can be modified as desired to alter the input to HE5. These examples illustrate how the template routines can be expanded to provide routines for IOP input, sky input, etc.
- **Data files.** These files provide input such as chlorophyll- or mass-specific absorption and scattering spectra for use in IOP models, scattering phase functions, sea-surface reflectance and transmission properties for different wind speeds, bottom reflectances, and atmospheric properties used by the default sky irradiance models. The distributed files will be sufficient for many users. However, users can add to this collection by putting their own data onto various “HE5 standard formats” or by making “specialized” runs (for example, to add additional phase functions) as described in the Technical Documentation.

- **Templates for creating user-supplied subroutines and data files.** Each of these routines is flagged in the source code by a statement of the form “Template for user-supplied ... routines.” The ellipsis describes the type of routine, e.g. “sky radiance” or “absorption and scattering.” These templates show the required formats for various routines that provide the core program with information about the absorbing and scattering properties of the particular water body being simulated, about the sky radiance distribution, and the like. Some users want to write their own versions of such routines in order, for example, to read in their own measured absorption and scattering profiles or to insert their own analytical models of the inherent optical properties. This can be done by inserting the desired FORTRAN code into the corresponding template.
- **Example simulations.** The input, run script, and output files for a few typical HE5 simulations are given for reference. Users should reproduce these simulations on their own computers after installation, in order to verify that HE5 is running properly on their computer.
- **Plotting routines written in IDL** (Interactive Data Language; IDL<sup>®</sup> is a product of ITT Visual Information Solutions.). These routines are, strictly speaking, not a part of the HE5 code. A small collection of example IDL routines is included for the convenience of users who have the IDL software package. Users may wish to ignore these routines and use other software (such as MATLAB) for graphical analysis of the HE5 digital output.

*Standard HE5 runs are those that result in a solution of the radiative transfer equation.* The routines for performing standard runs are found in the HE5\code directory. The code routines use the available collection of phase-function, sea-surface, and other data files along with the user input provided at run time to solve the radiative transfer problem defined by the input. Standard runs are often made in a series, with only minor changes in the input for each run (e.g., a change in the solar zenith angle or in the chlorophyll profile, with all other input being held constant from one run to the next). Standard runs will constitute almost all of the HE5 runs made by most users.

*Special runs are those that are made for adding either new phase functions or new sea-surface data files to the available collection of data files.* Special runs are made only once for a given phase function or surface conditions (wind speed, temperature, and salinity). The routines in directory HE5\SpecialRuns\PhaseFunction are used to prepare a scattering phase function for use by the HE5 main code. (This preparation is called discretizing the phase

function.) These calculations need to be done only once for a given phase function and quad partition. The use of these routines is described in the Technical Documentation.

HE5 contains surface data files for wind speeds from 0 to 15 m s<sup>-1</sup> and water indices of refraction of  $n = 1.32$  to 1.38. These values cover the ranges needed for most oceanic conditions and for which the underlying Cox-Munk surface wave-slope model is valid. (The surface data files themselves are found in the HE5\data\surfaces directory. A file named surfwind\_1321.2 corresponds to an index of refraction of 1.321 and a wind speed of 2 m s<sup>-1</sup>.) The files distributed with HE5 are adequate for almost any oceanographic application. Creating new surface files is not trivial; contact us for user support if you think you need surface files for a different range of conditions (e.g., if you need to model an ocean of liquid methane on Saturn's moon Titan) .

***Note also that if you change the quad or band partitioning from the defaults shown in Figures 2 and 5, all phase functions and surface files must be recreated via special runs.*** This is a considerable undertaking; read the Technical Documentation and contact us for user support if you need a different quad or band resolution.

## 4.2 File Naming Conventions

Although it is claimed that recent versions of Windows allow the use of long directory and file names, this is true only if you stay in the point-and-click world. Unfortunately, the command windows of Windows 98 to XP, for example, are essentially still DOS. This means that names longer than 8 characters sometimes get truncated when you are working in a command window, which is where HE5 compiles and runs. To allow users to include data files with long file names (up to 32 characters) a special subroutine (IOshorten.f90) is included to allow HE5 to interface with Windows and look up the 8.3 format DOS filename. Thus if you tell the frontend program that your ac-9 data is on a file named mygreatac9data.txt, the file name is truncated to mygreaa~1.txt by the operating system (where the number after the tilde is set by the system), yet HE5 will still be able to find the right file.

Part of the input to a HE5 run is a single-word “root” name that is used to construct the names of all input and output files associated with that run. Thus, after running the front-end, the input to HE5 will be found on a file named lroot.txt, where “root” has been replaced by the chosen identifying name, e.g. lupcast2.txt if root = upcast2. After the run finishes, the printout will be found on file Proot.txt (e.g., Pupcast2.txt), and so on. The following input

file is created for every HE5 run:

**lroot.txt** the file containing the Input specifying the run (see the Technical Documentation for a detailed description of this input). Written by the UI to the HE5\run\batch directory.

This input file is the same for either a HydroLight or EcoLight run.

If the run calls a user-defined IOP model, includes bioluminescence, or calls a user-defined function to define any of the component concentrations, then a run-specific version of the HE5 code will automatically be compiled and the following additional input file will be generated:

**Root.for** the file containing subroutines that call the appropriate user-defined IOP and sky models specified for this run, including the sky parameters. Written by the UI to the HE5\code\batch directory, if needed.

These two files contain all of the information specific to each run. The HE5\run directory contains two executables, `run_HL.exe` and `run_EL.exe`, along with a list of runs to be made, named `runlist.txt`.

When you make an HE5 run, you execute `run_HL.exe` (by choosing “run HYDROLIGHT now” on the last form of the UI, double clicking `run_HL.exe`, or by going to `start->run->run_HL.exe`; see §9.3 of the Technical Documentation for instructions on making “manual” runs). `run_HL.exe` reads the file `runlist.txt` containing a list of `lroot.txt` filenames (one or more) that are part of the current “batch” of runs. The runs listed in `runlist.txt` are submitted by `run_HL.exe` sequentially to HE5. Thus you can always re-run a simulation made earlier, and you can build up batches of previously defined runs by simply adding their `lroot.txt` filenames to the `runlist.txt` file in the run directory. The executable `run_HL.exe` does the following:

1. takes care of submitting runs in a batch (even if the “batch” only has one run),
2. *only if necessary* copies the run-specific FORTRAN file from the `code\batch` directory into the `code` directory as `incfiles_user.for`, and compiles a new executable, `mainHL_user.exe`,
- 3 sends the run names to `spawnHL_X.bat` (in the `code` directory) to be run, and
4. waits for the run to finish before starting the process for the next run listed in `runlist.txt`

and repeating steps 2-4 until all runs are completed.

Step 2 occurs only if a user-defined subroutine needs to be compiled. For the majority of users, HE5 will never need to recompile. For this reason, most runs are handled by the executable `mainHL_std.exe` and utility `spawnHL_std.bat`. If the code is recompiled, the run will create and use the executable `mainHL_user.exe` and utility `spawnHL_user.bat`. These issues are handled automatically by `run_HL.exe`.

When you make an `ECOLIGHT` run, you execute `run_EL.exe` (by choosing “run `ECOLIGHT` now” from the UI, double clicking `run_EL.exe`, or by going to `start->run->run_EL.exe`). `run_EL.exe` reads the same input (`Iroot.txt`) file as HE5 but submits runs to the `EcoLight` executable. In this way, once you have defined a run, you can choose to run it under `HydroLight` or `EcoLight` at any time without re-running the UI or changing your input. In fact, from the final screen of the UI, you can submit the run to both `HydroLight` and `EcoLight` for a side-to-side comparison of the irradiances or other common outputs.

After the run finishes, the printout for each run will be found on file `Proot.txt` (e.g., `Pupcast2.txt`), and so on. `HydroLight` output is written to the `HE5\output\Hydrolight\printout` directory and `EcoLight` output is written to the `HE5\output\Ecolight\printout` directory. The following output files can be created for each run by checking the appropriate boxes on the `OUTPUT OPTIONS` form of the UI:

- |                        |   |
|------------------------|---|
| <code>Droot.txt</code> | the file containing the full <u>D</u> igital output from the run (usually used as input to a graphics package). Written to the appropriate <code>digital</code> directory (i.e., to <code>HE5\output\Hydrolight\digital</code> or to <code>HE5\output\Ecolight\digital</code> ) |
| <code>Lroot.txt</code> | the file containing the full radiance output from the run. Written to the appropriate <code>digital</code> directory.   |
| <code>Mroot.txt</code> | the file containing the <u>M</u> ulti-wavelength-format output for postprocessing with <code>excel</code> . Written to the appropriate <code>excel</code> directory ( <code>HE5\output\Hydrolight\excel</code> or <code>HE5\output\Ecolight\excel</code> ).                     |
| <code>Proot.txt</code> | the file containing the <u>P</u> rintout from the run, usually used for a “quick look” at the output. Written to the appropriate <code>printout</code> directory (i.e., to <code>HE5\output\Hydrolight\printout</code> or to <code>HE5\output\Ecolight\printout</code> ).       |

**Sroot.txt**      the file containing the Single-wavelength-format output for postprocessing with EXCEL. Written to the appropriate `excel` directory.

On the final form of the UI, users have the option of selecting how much output is generated for their run. For example, a user who does not process output in EXCEL should elect not to generate the `Sroot.txt` and `Mroot.txt` files.

### 4.3 Directory Structure

The HE5 package is installed by default on the user's computer as a main directory named HE5. On a PC, this directory might have the full path name `c:\HE5` or `c:\Program Files\OceanOptics\HE5`, depending on how the user likes to organize his or her computer system. You can, if desired, rename the main directory (for example, if you wish to have more than one copy of HE5 installed for work on different projects, or if different users are working on the same computer and each has his or her own copy of HE5.) In any case, the HE5 code uses path names relative to the main directory (which is referenced as “.” in the Windows operating systems), so that the actual name of the main directory does not matter. ***The main HE5 directory has a number of subdirectories whose names must not be changed.*** All of the computations within an HE5 run are done within the subdirectories. Figures 6(a) and (b) show the layout and names of the subdirectories. Figure 6(a) shows the directories used in standard runs while Figure 6(b) shows the complete structure of the HE5 software package.



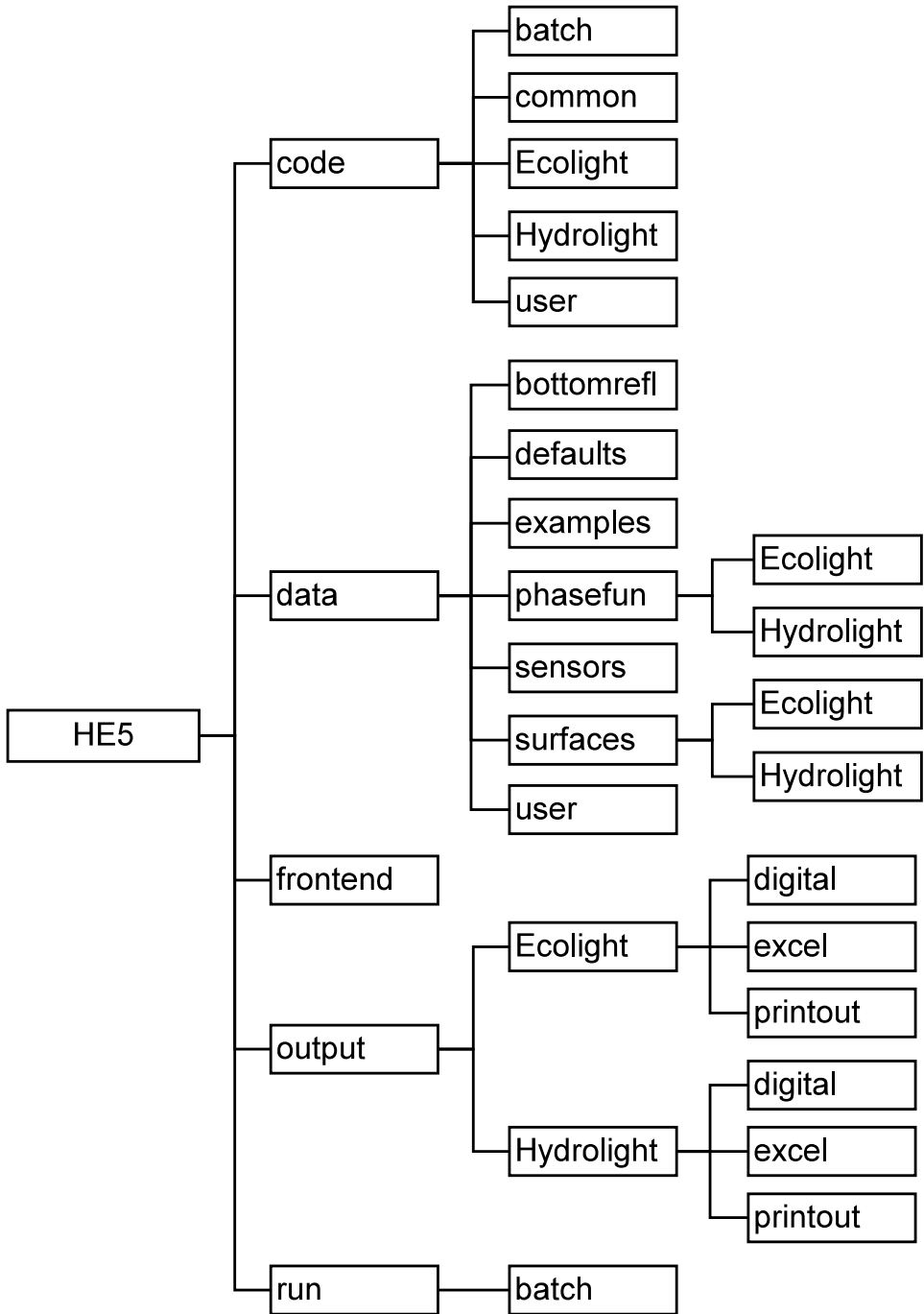

Figure 6(a). The HE5 directories used in standard runs.

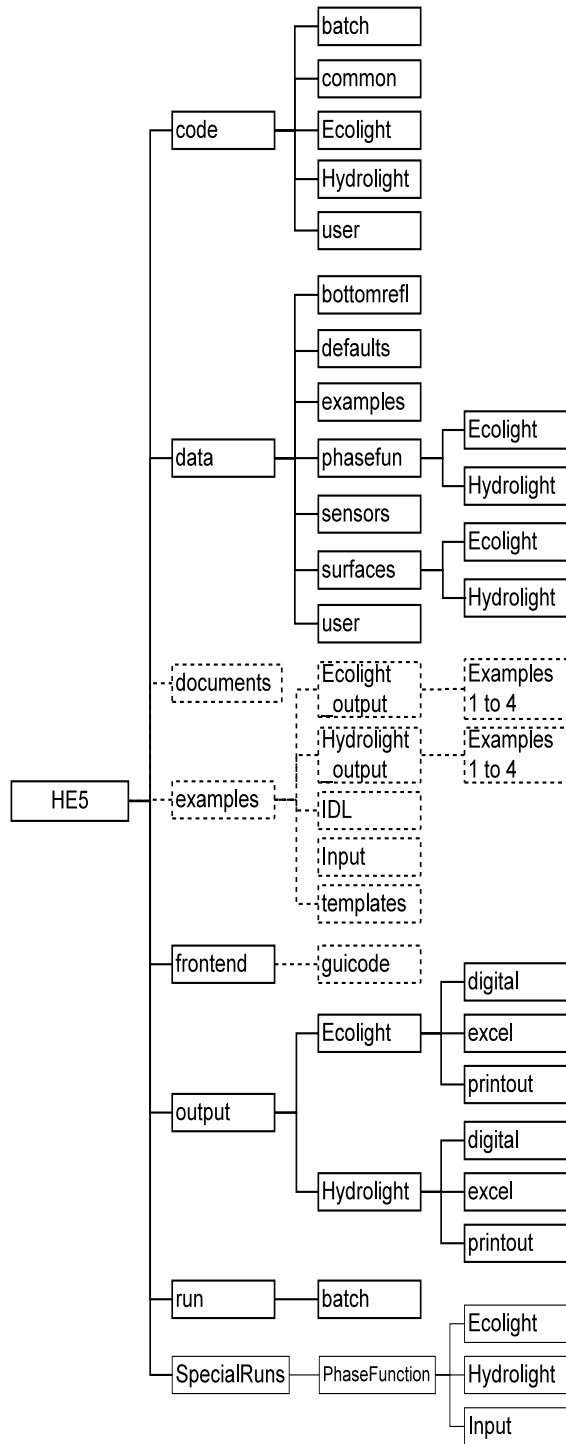

Figure 6(b). The complete HE5 directory structure. The heavy boxes show the directories involved in HE5 standard runs, as shown in Fig. 6(a). The light boxes show directories used in special runs. The dotted boxes show directories containing files that may be of interest to some users, but which are not required for HE5 runs.

The contents of the various HE5 directories are as follows:

- code** contains the executables and FORTRAN source code for the HE5 standard runs.
  
- batch** is the directory where the UI writes the run-specific FORTRAN file (`root.for`), if that file is needed.
  
- common** contains the source code common to both EcoLight and HydroLight. This code includes IOP and other routines that do not depend on the directional quad or band partitioning.
  
- Ecolight** contains the source code particular to EcoLight. These routines depend on the band partitioning.
  
- Hydrolight** contains the source code for HydroLight. These routines depend on the quad partitioning.
  
- user** contains any user-supplied subroutines and functions. All contents of this folder will be compiled and linked to create the executable, so each routine **MUST** have a unique name.
  
- data** contains the input data files for a run. Initially, this directory contains files with the pure water absorption and scattering coefficients and a few example files of ac-9 and chlorophyll data. This directory also has five subdirectories for holding particular types of input:
  - botmrefl** contains files of bottom reflectances. As distributed, this directory contains example files for different bottom types. Users can add their own files of measured bottom reflectances to this directory.
  
  - defaults** contains files of specific absorption and scattering coefficients, as taken from the literature, which are used by the IOP models. Users can add their own files of measured or modeled values to this directory.

<b>examples</b>	contains examples of the various data file formats expected by HE5 for input. Some of these files are used in the example runs described in §6, but are not intended for general use.
<b>phasefun</b>	contains files of discretized phase functions created by the code in directory HE5\SpecialRuns\PhaseFunction. Initially, this directory contains files (named *.dpf for <u>d</u> iscretized <u>p</u> hase <u>f</u> unction) for various phase functions. There are separate subdirectories for the HydroLight and EcoLight phase functions, since the phase function discretization depends on the quad and band resolution. Users can add their own files of discretized phase functions to this directory by making special runs as described in the Technical Documentation §9.2.
<b>sensors</b>	contains files defining sensor-specific wavebands. Users can add their own files of wavebands to this directory. The name of the sensor must be added to <b>sensorlist.txt</b> for the name to appear in the pull-down box of the UI. Note: the file corresponding to a given sensor must be the sensor's name with the txt extension added (e.g., the wavebands corresponding to SeaWiFS are stored in the <b>SeaWiFS.txt</b> file in this directory).
<b>surfaces</b>	contains files of sea-surface information for different wind speeds and water indices of refraction. There are separate subdirectories for the HydroLight and EcoLight, since the surface files depend on the quad and band resolution.
<b>user</b>	Users can add their own data files to this directory. It is a good idea to keep user data files separate from the distributed data files in the preceding directories. As distributed, this directory is empty.
<b>documents</b>	contains PDF versions of this Users' Guide, the Technical Documentation, various HydroLight Technical Notes, as well as any readme files or release notes.

**examples** contains templates for user-supplied subroutines, example IDL routines, and the input, run script, and output files for the example simulations presented in Section 6.

**Ecolight\_output** contains the output files for the simple single-wavelength, radiative transfer simulation example.

**example1** contains the input, run script, and output files for the simple single-wavelength, radiative transfer simulation example described in §6.1.

**example2** contains the input, run script, and output files for the multi-wavelength, Classic Case 1 water simulation example described in §6.2.

**example3** contains the input, run script, and output files for the multi-wavelength, NEW Case 1 water simulation example described in §6.3.

**example4** contains the input, run script, and output files for the Case 2 water example run using SeaWiFS wavebands, as described in §6.4.

**Hydrolight\_output** and its subdirectories contain the corresponding HydroLight files for the example simulations.

**IDL** contains selected IDL routines used in producing this Users' Guide. These routines are designed to read the full-output digital data files (the optionally created **Droot.txt** files).

**input** contains the input files for the four example runs.

**templates** contains templates for creating various user-defined subroutines (e.g., for IOP or sky models) and data files (e.g., for ac-9 or chlorophyll profiles).

**frontend** contains the executable UI front-end program for Windows (file **HE5WinFE.exe**) as well as various files needed by the UI.

**guicode** contains the Visual Basic® 5.0 source code for the UI front end, and associated files and figures. This directory is not included on the HE5 distribution CD because almost no one needs to modify the user interface. However, the UI source code will be provided to users who request it.

**output** contains all of the output files written by HE5 during execution. There are separate subdirectories for the output from HydroLight and EcoLight runs.

**EcoLight** contains the EcoLight run outputs in various subdirectories, as follows:

- excel** contains files associated with EXCEL spreadsheets. This directory initially contains the two macros (files **singlewl.xls** and **multiwl.xls**) that open the corresponding HE5 spreadsheet output files (files **Sroot.txt** and **Mroot.txt**, respectively) as EXCEL workbooks. EcoLight writes its spreadsheet output files (if requested as output) to this directory.
- digital** is the directory where EcoLight writes the full-output digital data files (the **Droot.txt** and **Lroot.txt** files) (if requested as output) from each run.
- printout** is the directory where HE5 writes the printout (file **Proot.txt**) from each run.

**HydroLight** contains the corresponding subdirectories for output from HydroLight runs

**run** contains the input (**lroot.txt**) files, and run list (**runlist.txt**), and run executables (**runEL.exe** and **runHL.exe**) needed to run the HE5 main code. These files are written by the front-end program.

**batch** is the directory where the UI writes the input files (**lroot.txt**) for each run.

**SpecialRuns** contains the code needed for special runs to discretize phase functions.

**PhaseFunction** contains the code needed for discretizing a phase function and creating new \*.dpf files. There are separate codes for HydroLight and EcoLight. See the Technical Documentation for more information.

## 5. THE USER INTERFACE

**Standard HE5 runs are those runs that solve the radiative transfer equation (RTE) for a given set of water IOPs and surface and bottom boundary conditions.** Because this is the mode of running HE5 that is employed most of the time by all users and all of the time by most users, it is described first. Most users will find the standard HydroLight quad layout seen in Fig. 2 and the EcoLight band layout of Fig. 5, the available wind speeds (0 to 15 m s<sup>-1</sup>), the available water indices of refraction (1.32 to 1.38), and the distributed selection of phase functions to be adequate. If this is not the case, then special runs to define new quad and band layouts, wind speeds, or phase functions must be made before making the desired standard runs. These special runs are described in the Technical Documentation §9.

A standard run takes information about the inherent optical properties of the water body and adds information about the sea-surface, the incident sky radiance distribution, and the bottom boundary. This information together completely defines a physical situation for which the RTE has a unique solution. The HE5 main code then solves the quad- or band-averaged RTE and generates the final outputs of the HE5 models. Monte Carlo ray tracing is used in the special runs that computed the sea-surface reflectance and transmittance functions. However, the standard computations are entirely deterministic; no Monte Carlo simulations are used to solve the RTE within the water body. This is one of the great numerical virtues of the invariant imbedding technique used in HE5.

The primary way to initiate a HE5 standard run is by running the user interface (UI) front-end program (Windows systems only). It is also possible to create the input file and run script (and included FORTRAN file `incfiles.for`, if required) with an ASCII text editor and then run HE5 from a command window. However, due to the many input options, this is a much more difficult endeavor than in previous versions and is therefore not recommended except in special applications by advanced users (such as running numerous HE5 simulations in parallel on a cluster of computers, for which the input files are mass produced by user-written codes). The input file format is described in detail in Appendix A of the Technical Documentation.

Standard runs are sometimes made in a series in which only one input variable such as the solar zenith angle, chlorophyll concentration, or bottom depth is changed between each run. Therefore, the User Interface has the option of saving the input values from the current run and using those values as the default values for the input to the next run. After making the first run of a series, the user then can quickly “click through” the UI windows, pausing only to change the input values that are to be different in the next run. Similarly, a user *who is familiar with*



*the input format* can quickly open the input file with a text editor, change a number or two, re-save the file, and submit the new run. However, this should be attempted only by users who are very familiar with how information is passed into HE5, in order to prevent inconsistencies between what problem you are solving and what problem you *think* you are solving.

Regardless of how a run is initiated, the user must give HE5 input that defines a unique radiative transfer problem for the environmental conditions of interest. When running the UI front end, these specifications are made by selecting allowed values for various parameters, by entering the names of files containing data such as chlorophyll profiles, or by entering lists of depths and wavelengths where the output is to be saved.

The purposes of the front-end program are to

- guide users through the specification of all of the input needed to define a unique radiative transfer problem
- use the users' responses to generate the various files needed to run HE5
- run HE5 to solve the specified radiative transfer problem

The UI front-end program consists of a number of windows, each of which prompts the user for a particular type of information, e.g., what IOP model to use, what bottom boundary condition to use, or what depth and wavelength resolution is desired in the output.

The usual problem-solving sequence is to work through the UI windows, run either HydroLight or EcoLight to solve the radiative transfer problem just defined, and then return to the start of the UI to specify the input for the next run. It is also possible to define a series of HE5 runs from within the UI and then run the whole series afterwards. In this case, the various input files are accumulated and then run as one "batch" run consisting of many individual HE5 runs.

This following pages briefly describe the input requested in the various windows of the UI front end. Many of the UI options have "tool tips" to provide additional information. Full documentation of the available models and features is given in the Technical Documentation.

## 5.1. Run Initializaion

**The Opening form.** When running HE5 for the first time, click the RESET DEFAULTS button. You will need to read and accept the DISCLAIMER and the LICENSE AGREEMENT before continuing. On subsequent runs, you can proceed immediately by clicking CONTINUE. Any time you wish to return to the default values (as distributed with the code) for the various parameters, just click RESET DEFAULTS. The USER SUPPORT form gives the information needed to assist with debugging any problems with HE5.

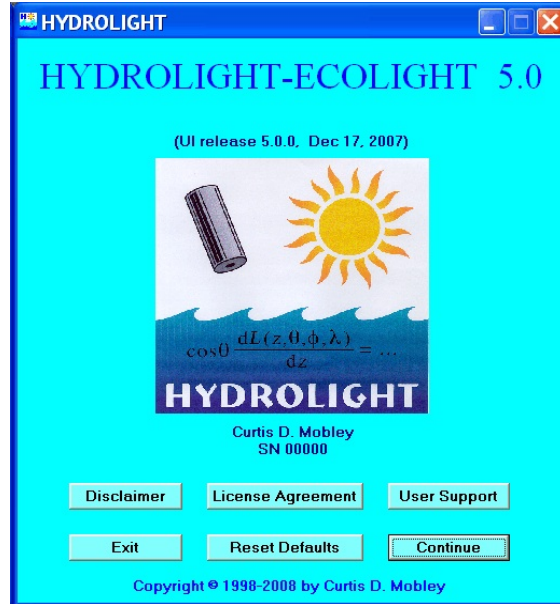

**The RUN IDENTIFICATION form.** This form first asks for the “root” name to be used in generating the file names for the run. Keep the root as one word (do not have any blanks or special characters not allowed in file names), up to 32 characters. Also enter a descriptive title for the run. This title will appear in the printout and other output files generated by the run.

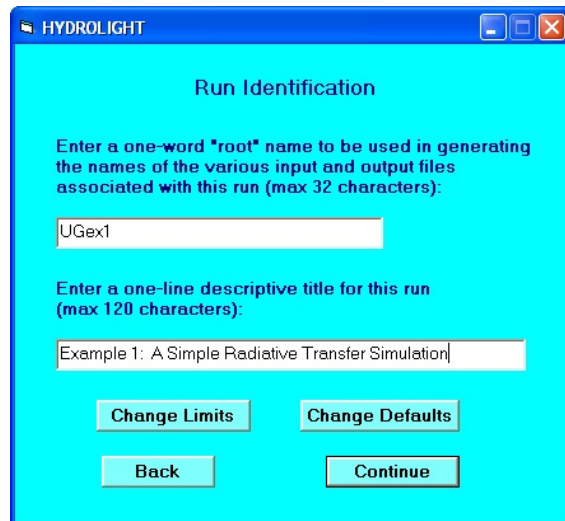

HE5 has the ability to accumulate a series of runs into a batch and then submit them all at once. HE5 will take care of remembering what runs you want to make and which models to use for each. However, *when creating a series of runs, be sure to give each one a new*

*root name. If a subsequent run has the same root name as a previous run, the output from the previous run will be overwritten without any warning.*

**The CHANGE LIMITS form.** If you click CHANGE LIMITS on the RUN IDENTIFICATION form you will be taken to a special form to specify maximum values of several parameters. Most users will never need to use this form. This form allows you to change the maximum number of output depths, number of IOP model components, etc. for your run. These values are used to dimension arrays within HE5. Note: these values do not need to equal the values for your run — they simply have to be at least as big. If you change any of these values, the compiler will force all of the routines to recompile.

The screenshot shows the 'HYDROLIGHT array dimensions' form. It has a blue header with 'HYDROLIGHT' in white. The title 'HYDROLIGHT array dimensions' is centered. There are three sections: 'Resolution' with 'Maximum number of output depths' (100) and 'Maximum number of output wavelengths' (150); 'Custom IOP model' with 'Maximum number of IOP model components' (4); and 'Custom quad layout' with 'Maximum number of polar (theta) quad bands in SPHERE (must be a multiple of 2)' (20) and 'Maximum number of azimuthal (phi) quad bands (must be a multiple of 4)' (24). A note states: 'NOTE: Any change to the default quad layout requires the USER to rediscritize all surface and phase function files BEFORE running HE5!'. At the bottom are 'Back', 'Reset to default values', and 'Continue' buttons.

**The DEFAULTS form.** If you click CHANGE DEFAULTS on the RUN IDENTIFICATION form you will be taken to a special form to specify several physical model parameters including which wavelengths to include in PAR calculations as well as inelastic scattering parameters such as fluorescent efficiency. Most users will never need to use this form.

The screenshot shows the 'HYDROLIGHT physical model parameters' form. It has a blue header with 'HYDROLIGHT' in white. The title 'HYDROLIGHT physical model parameters' is centered. There are two main sections: 'Wavelength range for PAR calculations' with 'Minimum wavelength included' (400) and 'Maximum wavelength included' (700); and 'Inelastic Scattering' with 'Chlorophyll fluorescent quantum efficiency' (0.02), 'Raman scattering reference wavelength (nm)' (488), and 'Raman scattering cross-section at reference wavelength (m-1)' (2.60e-4). A checkbox is checked for 'Allow dynamic lower boundary depth when the infinitely deep bottom boundary is selected'. At the bottom are 'Back', 'Reset to default values', and 'Continue' buttons.

When you click CONTINUE from the RUN IDENTIFICATION form, a pop-up box will show you the names of the files that will be generated. You can select not to have this form displayed on subsequent runs.

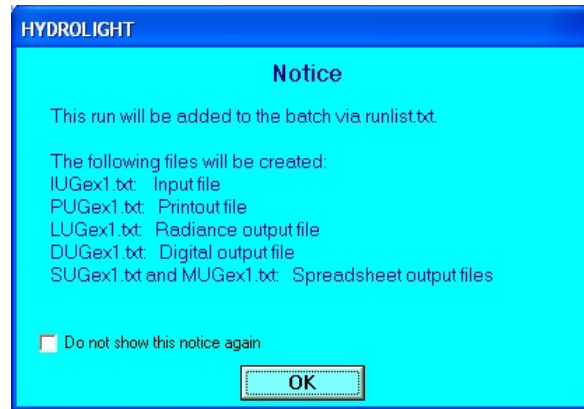

## 5.2. IOP Specification

**The IOP SPECIFICATION form.** This form requires you to pick an IOP model, i.e., a model for the absorption  $a$  and scattering  $b$  coefficients and scattering phase functions that describe the water body. **The available IOP models are described in detail in the Technical Documentation.** The input required by various IOP models differs; the needed information will be requested on the next forms, depending on which option is selected on this form. Six options are available on this form:

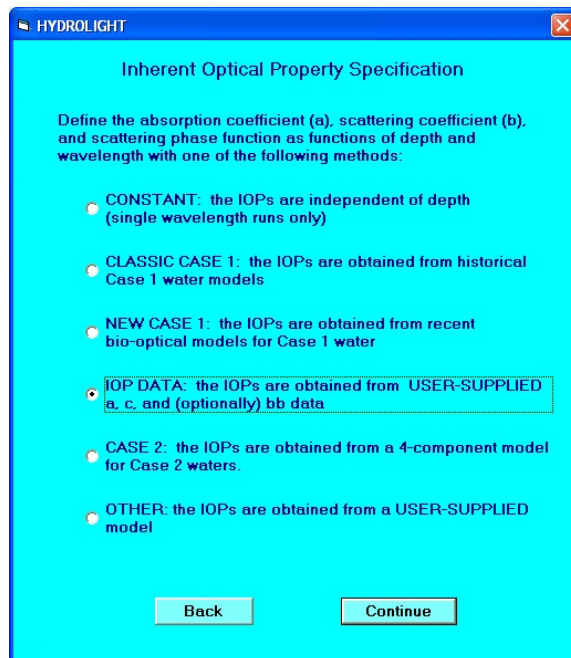

CONSTANT. This IOP model describes the water body by its total absorption and scattering coefficients and phase function; the water is taken to be homogeneous. This model is useful only for idealized radiative transfer studies done at one wavelength.

CLASSIC CASE 1. This IOP option selects a simple, frequently used (“Gordon-Morel” type) bio-optical model for Case 1 water, which uses simple equations to obtain the absorption and scattering coefficients for chlorophyll particles and co-varying CDOM from a user-specified chlorophyll concentration. It is intended for use only in Case 1 water. This is the same IOP

model that was called “Case 1” in previous versions of HydroLight. This model is retained in HE5 for comparison purposes with the NEW CASE 1 IOP model. Users are encouraged to use either the NEW CASE 1 or the CASE 2 IOP models for general simulations. The CASE 2 IOP model is the most general of the standard IOP models.

○ NEW CASE 1. This IOP model for Case 1 waters is based on recent publications. The absorption and scattering coefficients and the scattering phase function are all determined by the chlorophyll concentration. The details of the model are given in the Technical Documentation. This model is for use only in Case 1 water.

○ IOP DATA. The IOPs are constructed as the sum of pure water values plus “everything else”—particles and dissolved substances—as measured by a WETLabs ac-9 or similar instrument, (other data on the same formats, e.g. from a WETLabs ac-s, can be processed with this model.) The input data file contains the absorption  $a$  and beam attenuation  $c$  coefficients as functions of depth and wavelength in the HE5 standard format described in the Technical Documentation. Optionally, backscatter coefficients measured by a WETLabs bb-9, HOBILabs HydroScat-6, or similar instrument can be used in conjunction with the  $a$  and  $c$  data to select phase functions with the measured backscatter fraction.

○ CASE 2. This general four-component Case 2 water model includes many options for specifying concentration profiles and IOP models for each of four components: water, chlorophyll-bearing particles, CDOM, and mineral particles. To make Case 1 runs using the Case 2 model, select the option to let CDOM “agree with the Case 1 model” and set the mineral concentration to zero.

○ OTHER. If you decide not to use any of the above provided IOP models, you can create your own IOP model. In this case, you may use the UI to specify your component IOPs by selecting the OTHER option, which will ask you to provide information for each component as well as the name of your “ab” routine. This option is for advanced users only, and ***it is your responsibility to insure that your routine properly uses the input provided in the UI.*** See the Technical Documentation for more information about developing your own IOP model.

If you change the IOP model between saved runs you will see this notice to remind you that when you change your IOP model, you need to make verify that the IOPs specified are consistent with your new model. HE5 will require you to view each of the IOP specification pages to make sure you are not accidentally using unintended values from a previous run.

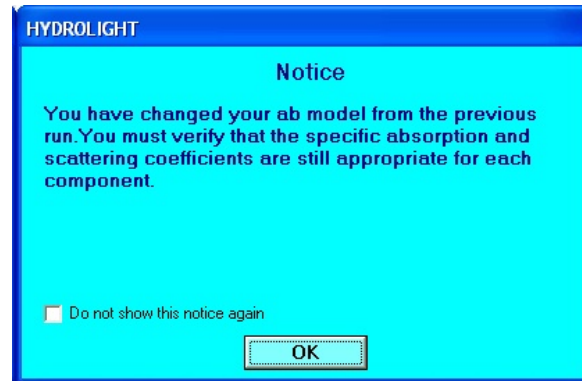

The next set of forms shows the input required by these different IOP models.

**The CONSTANT form.** This form requests the input needed by the CONSTANT IOP model. The water is modeled as a single component having the specified total absorption, total scattering, and phase function. Even though the water IOPs are specified once  $a$ ,  $b$ , and the phase function have been selected, the form also requests a wavelength for the run; the wavelength may be needed by the sky and/or bottom models. Since the wavelength will be specified here, the wavelength specification form (described below) will not appear with the CONSTANT model. The code for the CONSTANT model is in file HE5\code\common\abconst.f.

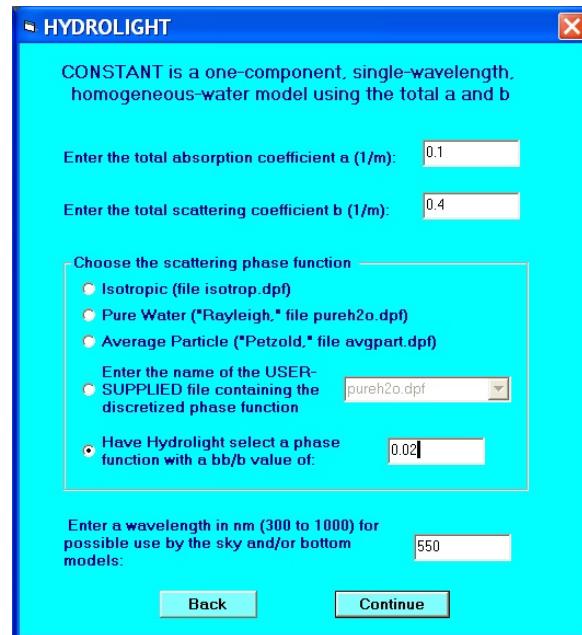

**The CLASSIC CASE 1 form.** This form requests the input needed by the bio-optical models used in the CLASSIC CASE1 IOP model. The water is modeled by three components: pure water, pigmented particles, and co-varying CDOM. The absorption and scattering properties of the particles and CDOM are parameterized by the chlorophyll concentration, which in general is a function of depth. The code for the CLASSIC CASE1 model is in file HE5\code\common\abcase1.f. Clicking on the “specify component IOPs” button will take the user to the IOP component specification form described below. Since the underlying model includes models for the specific absorption and scattering of chlorophyll-bearing particles (phytoplankton), they are not included on the component forms.

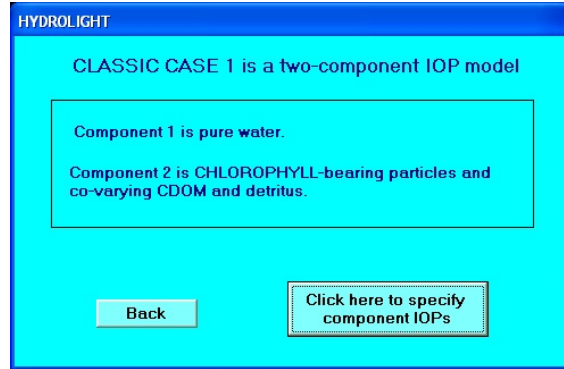

**The NEW CASE 1 form.** This is a recently developed (for HE5) alternate model for Case 1 water. This IOP model has four components: pure water, large particles, small particles, and CDOM, each of which covaries with the chlorophyll concentration. The chlorophyll concentration is the only input required by this model. The code for the NEW CASE1 model is in file HE5\code\common\abnewcase1.f.

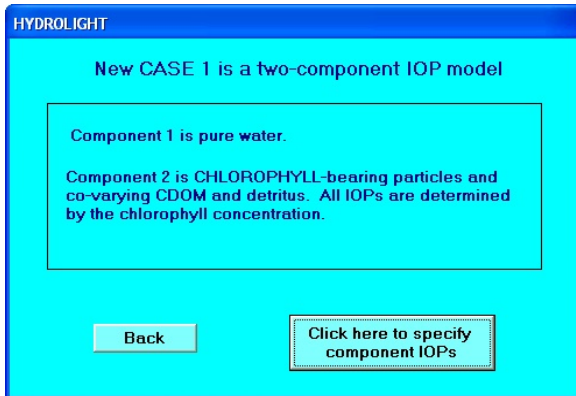

**The IOP DATA form.** In this IOP model, the water is modeled by two components: pure water and “everything else” (particles and CDOM). Measured absorption ( $a$ ) and beam attenuation ( $c$ ) data as obtained from a WETLabs ac-9 (or similar) instrument are

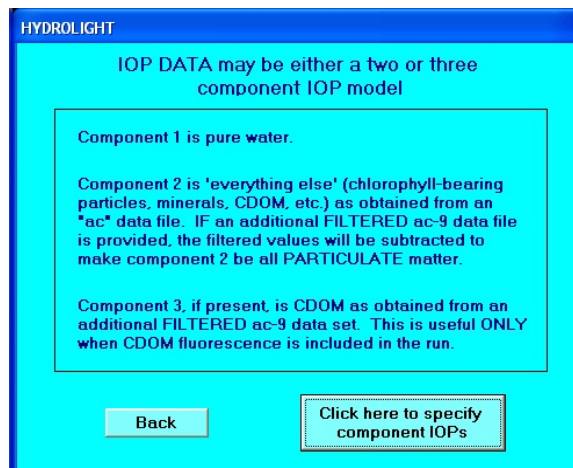

used to determine the IOPs of the second component. An optional third component will be added if and only if CDOM fluorescence is included, in which case absorption due to CDOM will be specified after the inelastic scattering form, where the user will have the option of providing a filtered ac-9 file for that purpose.

The component specification form for IOP DATA is slightly different than for the other components. The absorption and beam attenuation coefficients are given as functions of depth and wavelength via the user-supplied data file, rather than as concentrations of chlorophyll or other components. There is an added option of specifying the phase function by using a file of backscatter data. If the backscatter option is selected, the backscattering ratio will be calculated for each depth and wavelength. The smoothness of the  $b$  and  $b_b$  data can affect the run time when this model option is used. The code for this model is in file HE5\code\common\abacbb.f.

**The CASE 2 form.** A basic, flexible case 2 water model is provided. The model has four components: pure water, chlorophyll-bearing particles, CDOM, and mineral particles. There are many options for specifying the IOPs of each component. The code is on file HE5\code\common\abcas2.f.

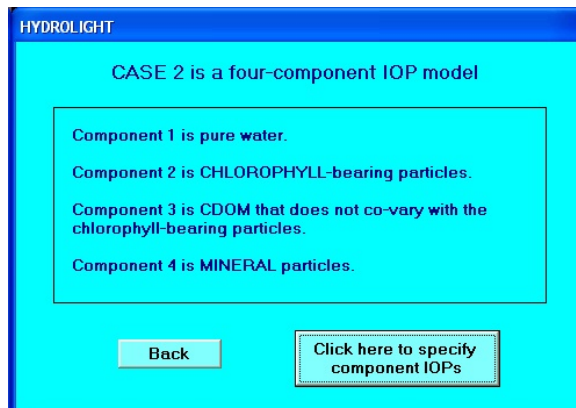

**The OTHER form.** This form allows you to select a user-written IOP model with up to four components (The number of components can be increased to 10 on the CHANGE LIMITS form.) (The abcas2 subroutine on file HE5\code\common\abcas2.f is an example of such a model with 4 components.) First, enter the name of the file containing the subroutine (“myIOPmodel” in this example form),

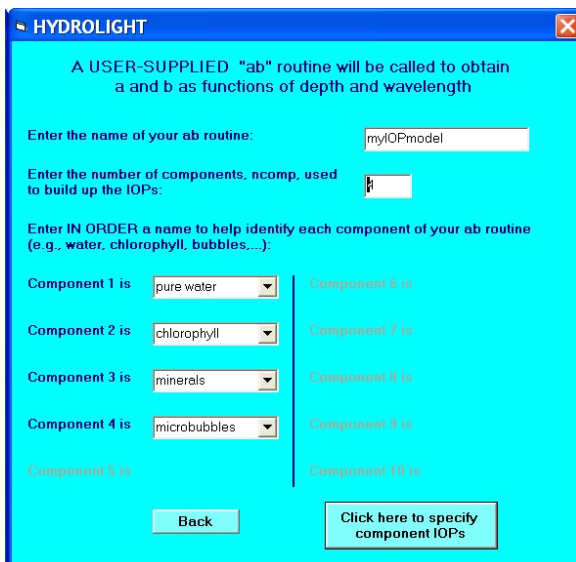



which must be in the HE5\code\user directory, and the number of components used in the subroutine to build up the IOPs (4 in this example). Then select a descriptive name to be used for each component of your IOP model. After each component is named on this page, the user will be asked to specify the IOPs for each one (in order) via the IOP SPECIFICATION FORM. Writing your own IOP model is not trivial and certain formats must be adhered to. See the Technical Documentation for information about writing your own IOP subroutines.

The IOP COMPONENT SPECIFICATION form. Once you have selected your IOP model, you will be asked to provide information specifying the IOPs of each component one at a time. In general, this will consist of providing the component concentration, information regarding the chlorophyll- or mass-specific absorption and scattering spectra for the component, and selecting a phase function. A series of windows will open, one for each component.

The needed concentration can be obtained by assuming it is constant with depth and entering its value, or by calling a *user-supplied* subroutine or a *user-supplied* file containing measured depth vs. concentration values. The chlzfunc.f file in the templates directory contains the format required for concentration subroutines, and the example chlzdata.txt file shows the format for concentration data files. The SEARCH FOR DATA FILE button allows you to browse your computer for data files.

***Note that concentration values must be consistent with your concentration-specific absorption and scattering spectra. For chlorophyll, this normally means that concentrations are in  $mg\ m^{-3}$ . For mineral particles, this normally means that concentrations are in  $gm\ m^{-3}$ .***

In addition to specifying the absorption and scattering coefficients, you must also specify the scattering phase function for each component. (Only the NEW CASE 1 IOP model does this automatically from the given chlorophyll concentration.). Phase function specification can be

done in three ways. The first is to use the pull-down menu to choose a phase function by the name of the file containing the discretized phase function. This option is useful if you have created your own phase function (via a special run, as described in the Technical Documentation). For example, the file named `avgpart.dpf` contains the discretized Petzold average particle phase function. The second option is to specify a value for the particle backscatter fraction  $b_b/b$ , which can have any value between 0.0001 and 0.50. For this option, HE5 generates a Fournier-Forand phase function with the given  $b_b/b$ , as described in the Technical Documentation. The same phase function is then used at each depth and wavelength. The third option is to specify  $b_b/b$  as a power law in wavelength. When this option is selected, the parameters for the power law will be specified on the next screen. For this option, HE5 again uses a Fournier-Forand phase function, but the particle backscatter fraction (i.e., the scattering phase function for the given component) will vary with wavelength but not with depth.

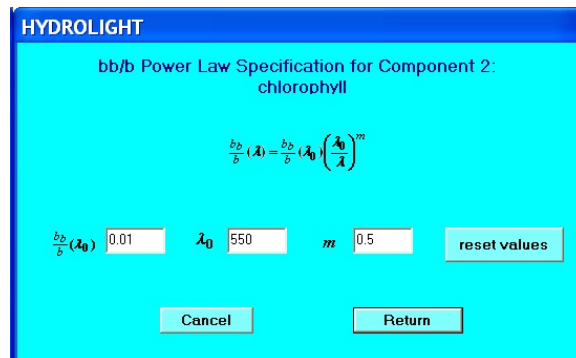

**The ABSORPTION SPECIFICATION form.**

Clicking the button to specify the absorption properties of a component will lead the user to a new window with options that depend on what is known about the component. Depending on what the component is and what IOP model is being used, some of the options may be unavailable (greyed out) or not visible.

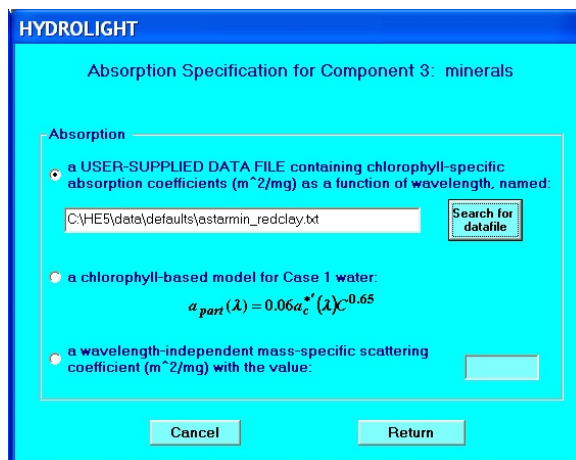

### The SCATTERING SPECIFICATION form.

Similarly, clicking the button to specify the scattering coefficient of a component will lead the user to a new window with options that depend on what is known about the component. An example is that no phase function or scattering coefficient options will be given if the component is CDOM (which is assumed to be nonscattering). There are a number of options for specifying the scattering coefficient. As discussed in the Technical Documentation §2.4.3, one option is to specify the wavelength dependence of the beam attenuation coefficient  $c$ , which generally better fits a power law in wavelength than does  $b$ , and then let HE5 obtain the scattering coefficient from  $b = c - a$ .

The screenshot shows the 'HYDROLIGHT' window with the title 'Scattering Specification for Component 3: minerals'. The main heading is 'Scattering (in terms of concentration X)'. There are four radio button options:

- a USER-SUPPLIED DATA FILE containing mass-specific scattering coefficients ( $m^2/mg$ ) as a function of wavelength, named:  Search for datafile
- a power law:  $c(\lambda) = c_0 X^n \left(\frac{\lambda_0}{\lambda}\right)^m$ 
  - for b
  - for c (b will be calculated as c - a)

Parameters:  $c_0$    $\lambda_0$    $n$    $m$

Buttons: Loisel-Morel near surface, Loisel-Morel all data, Gordon-Morel values, Use GAM model Params
- a linear relation:  $b(\lambda) = b_0 X^n \frac{(m\lambda + i)}{(m\lambda_0 + i)}$ 

Parameters:  $b_0$    $\lambda_0$    $n$    $m$    $i$
- a wavelength-independent mass-specific scattering coefficient ( $m^2/mg$ ) with the value:

Buttons: Cancel, Return

### 5.3 Inelastic Scattering and Bioluminescence

#### The INTERNAL SOURCE AND INELASTIC SCATTER form.

This form allows you to specify whether the run will include internal sources (e.g., *horizontal layers* of bioluminescence) or various kinds of inelastic scattering processes. Except for Raman scattering, which is determined by water alone, choosing one of these features may require you to specify additional information on subsequent forms. This most often occurs when the IOP data model is selected. That model lets you read in the total absorption and scattering coefficients, but it does not specify how much of the total absorption is due to chlorophyll or CDOM individually. If you

The screenshot shows the 'Hydrolight' window with the title 'Internal Source and Inelastic Scatter Selection'. The main heading is 'Specify whether the run will include bioluminescence and/or inelastic scattering'. There are two sections:

- Bioluminescence**
  - Bioluminescence
  - read from a DATA FILE named:  Search for datafile
  - read from a SUBROUTINE named:
- Inelastic scatter**
  - Chlorophyll Fluorescence
  - CDOM Fluorescence
  - Raman Scattering

Buttons: Back, Continue

wish to include chlorophyll or CDOM fluorescence, you must therefore specify how much of the total absorption is due to those components. The UI will ask you for that information if needed.

If chlorophyll fluorescence is included, the absorption values specified by the run will be used, along with the chlorophyll fluorescence quantum efficiency (set on the `CHANGE DEFAULTS` form) and the appropriate wavelength redistribution function from `code\common\wrfunc.f`. If, for example, CDOM fluorescence is included in the run but CDOM is not a component of your IOP model, checking the “CDOM fluorescence” box causes a special form to appear allowing you to specify CDOM absorption. This subroutine will be called to get the CDOM absorption as a function of depth and wavelength, which must be known in order to compute the CDOM fluorescence. The same is true for Chlorophyll.

After you click `CONTINUE`, a notice box reminding you how the fluorescing components have been specified (earlier in the run) will appear. Note that if inelastic scatter is to be included in the run, the relevant excitation and emission wavelengths must be included (to be specified on the wavelength form). Therefore, the inelastic-scatter options are not available if you selected the `ABCONST` IOP model, which is for runs at only one wavelength. Likewise, you cannot choose to do a run at only one wavelength if you have selected to include inelastic scatter.

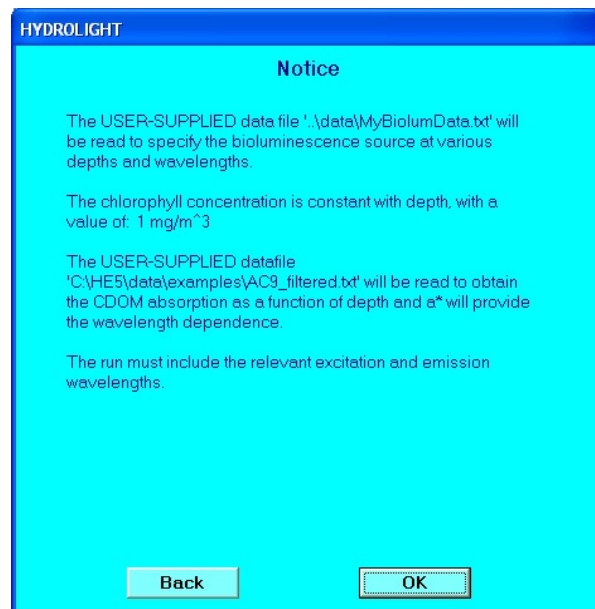

## 5.4 Wavelength Specification

**The WAVELENGTH SELECTION form.** This form allows you to select the wavelength range and bandwidths for the run. In the present example, the option of making the run at a single wavelength is not available because fluorescence and Raman scatter were included on the previous form. Suppose that you are interested only in the 400-600 nm range. In order to include CDOM-fluoresced light that is excited in the near UV and emitted at blue wavelengths, the run should be started at around 350 nm.

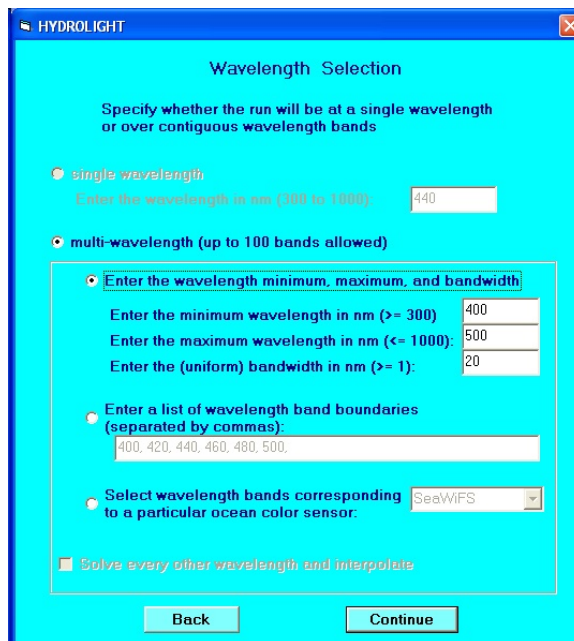

The screenshot shows the 'Wavelength Selection' dialog box in the HYDROLIGHT software. The dialog has a blue title bar with the text 'HYDROLIGHT' and a close button. The main area is white with a blue border. It contains the following elements:

- Title:** Wavelength Selection
- Instruction:** Specify whether the run will be at a single wavelength or over contiguous wavelength bands.
- Radio Buttons:**
  - single wavelength
  - multi-wavelength (up to 100 bands allowed)
- Form Fields:**
  - Under 'single wavelength': 'Enter the wavelength in nm (300 to 1000):' with a text box containing '440'.
  - Under 'multi-wavelength':
    - Enter the wavelength minimum, maximum, and bandwidth
      - Enter the minimum wavelength in nm (>= 300): 400
      - Enter the maximum wavelength in nm (<= 1000): 500
      - Enter the (uniform) bandwidth in nm (>= 1): 20
    - Enter a list of wavelength band boundaries (separated by commas):
      - Text box containing: 400, 420, 440, 460, 480, 500.
    - Select wavelength bands corresponding to a particular ocean color sensor: SeaWiFS (dropdown menu)
- Checkboxes:**
  - Solve every other wavelength and interpolate
- Buttons:** Back and Continue.

Rather than specifying the wavelengths explicitly, you can use the pull-down menu to select wavelengths that match various common sensors such as SeaWiFS or MODIS. The output will then contain those sensor bands (and intermediate bands; see Fig. 12) for ease of comparison with measurements.

If uneven bandwidths are desired (e.g., to exactly match the bandwidths of a particular sensor not available in the pull-down menu), the band boundaries can be entered manually, e.g., 400, 410, 425, 440, 450,.... Note that HE5 must always run with contiguous wavelength bands. For example, you cannot make a single run with a band from 400-410 and then another band from 435-445 nm without also including one or more bands in the 410-435 nm region. This is because the intermediate bands may contribute to the inelastically scattered light at the bands of interest.

However, if inelastic scatter is not included, there is an option to run only every other wavelength band and then fill in the uncomputed bands by interpolation between the computed bands. This option is intended for use when output is needed at high wavelength resolution (such as 5 nm band widths) for other applications, but when the IOPs and bottom boundary conditions do not vary rapidly with wavelength. Solving every other wavelength will cut the run time approximately in half.

## 5.5 The Air-Water Interface and Sky

**The AIR-WATER SURFACE BOUNDARY CONDITIONS form.** This form selects the wind speed to be used in modeling the roughness of the sea surface and the sky model to be used in modeling the incident sky radiance distribution. Although HE5 itself uses wind speed in units of  $\text{m s}^{-1}$ , users can enter the current wind speed in any of three units of measure. Clicking the “update” button will cause the UI to recalculate in all three units. The “semi-empirical” sky model is recommended for routine use in oceanographic studies.

**The SEMI-EMPIRICAL SKY form.** This form requests the input needed by the routines that together form the semi-empirical sky radiance model, which is based on the RADTRAN model for clear sky irradiances (Gregg and Carder, 1990, as extended in HE5 to the 300-1000 nm range. See the RADTRAN-X discussion in the Technical Documentation §5.1 for details). You can specify either the solar zenith angle or the time and location, from which the solar zenith angle will be computed by HE5. If you choose the option to use climatological ozone values, then the time and location information is needed to access the database of TOMS ozone values. See the Technical Documentation for a discussion of these climatological ozone values.

HE5 uses decimal format (day of year and decimal hour of day) for time. The UI will calculate the day of the year and time in decimal format for you, if you prefer to use the month/day/year/hour/minute format. Simply click the SPECIFY TIME AS MDY... button. After you have entered the data and press continue, the UI will perform the calculations and the decimal values will be placed in the appropriate boxes on the previous form.

Similarly, latitude and longitude can be specified in degrees, minutes and seconds (DMS) by clicking on the SPECIFY LOCATION IN DMS button.

**The RADTRAN ATMOSPHERIC PARAMETERS form for semi-empirical sky radiances.**

Users can specify various atmospheric parameters used by RADTRAN-X to calculate the irradiance at the sea surface. If not specified here, the 24-hour average windspeed will be set to be equal to the current windspeed (set in the air-water surface boundary form). You can enter an ozone concentration in Dobson units; entering a concentration of -99 will cause the climatological ozone value for your time and location to be used. The ozone concentration is important only if you are interested in irradiances below ~340 nm.

**The SEMI-EMPIRICAL SKY RADIANCE form.**

The wavelength-dependent sky irradiances can be specified either from RADTRAN or from a user supplied data file. The subroutine that sets the *angular pattern* of the sky radiance is specified here (the default is HCNRAD, which gives the Harrison and Coombes Normalized Radiances; see Harrison and Coombes, 1988). The name of a user-written subroutine to replace HCNRAD can also be entered. See the Technical Documentation for details.

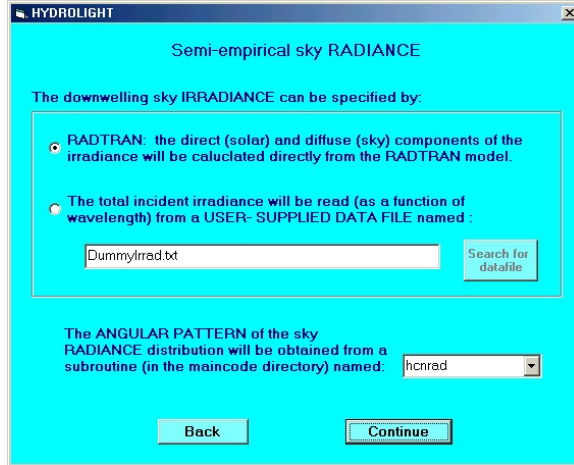

**The IDEALIZED SKY RADIANCE form.**

This form requests the input needed by the routines for the idealized sky radiance model (see the Technical Documentation for details). This sky radiance model is intended only for idealized radiative transfer studies that require a simple analytical model for the sky radiance distribution (such as a sun in a black sky or a heavy overcast). This sky radiance model is only available for use with single wavelength runs, because it cannot account for the wavelength dependence of the sky radiance.

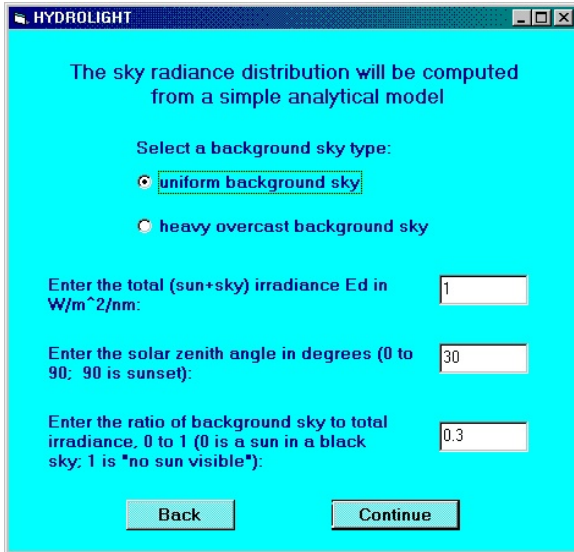



## 5.6 Bottom Boundary Condition

### The BOTTOM BOUNDARY CONDITION form.

This form requests the information needed to specify the bottom boundary condition. If the water is infinitely deep, the IOPs at the deepest depth of interest (to be specified on the output depth form) will be used to compute the reflectance (actually, the non-Lambertian BRDF) of the infinitely deep layer of water below the region of interest. If the water is finitely deep, the irradiance reflectance of the bottom must be specified. In the option shown, the pull-down menu is used to select one of the available files of user-supplied bottom reflectance vs. wavelength data for a Lambertian bottom.

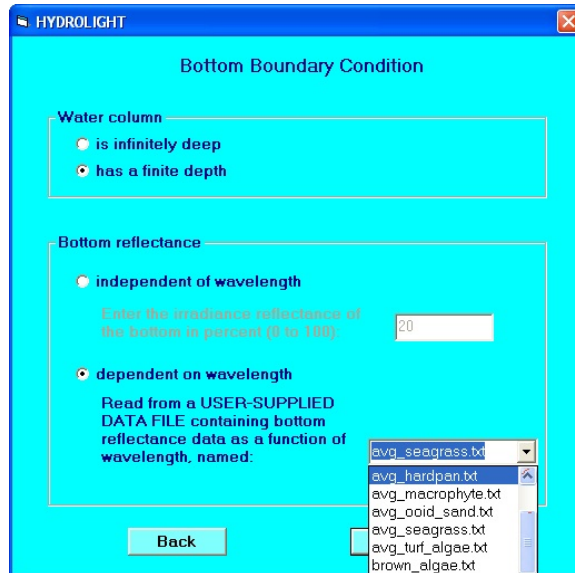

## 5.7 Output Depth Options

**The OUTPUT DEPTHS form.** This form specifies the depths at which output from the run is to be saved for later analysis. Note that *the depths at which output is to be saved does not affect the value or accuracy of the output at a given depth.* In the example shown, output is saved every 5 m down to 30 m. However, if output were being saved only at depths 0, 15, and 30 m, the output at those three depths would be the same, but you would not have the additional values at the other depths. Note that the option of having the listed depths be optical depths is not available in this example, because we already have chosen

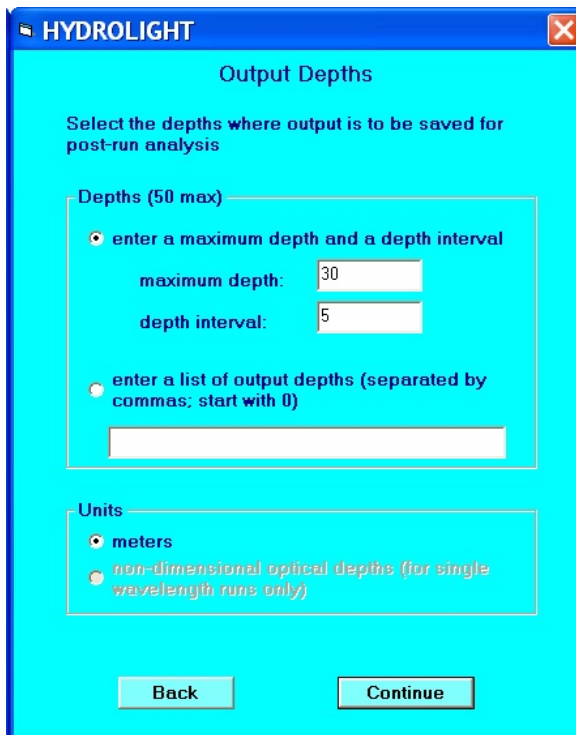

to have a multi-wavelength run. If you wish to have irregularly spaced output depths, e.g., to obtain greater resolution near the surface or bottom boundary or near an internal scattering or absorbing layer, you can enter the desired output depths explicitly. You can change the maximum number of output depths in the CHANGE LIMITS form on the RUN IDENTIFICATION form.

**There is an important difference in the output depths as used in HydroLight vs. EcoLight when computing the diffuse attenuation functions  $K_d$ ,  $K_u$ ,  $K_{Lu}$ , etc. from the corresponding irradiance or radiance.  $K_d(z,\lambda)$  for example, is computed from  $E_d(z,\lambda)$  using the definition of  $K_d$  as a logarithmic derivative, which is then approximated as a finite difference using two output depths  $z_2$  and  $z_1$ , where  $z_2 > z_1$ :**

$$\begin{aligned} K_d(z,\lambda) &\equiv -\frac{d \ln E_d(z,\lambda)}{dz} \\ &= -\frac{\ln E_d(z_2,\lambda) - \ln E_d(z_1,\lambda)}{z_2 - z_1} \\ &= -\frac{\ln [E_d(z_2,\lambda) / E_d(z_1,\lambda)]}{z_2 - z_1} \end{aligned}$$

**HydroLight computes these finite differences using two very closely spaced depths  $z_2$  and  $z_1$ , whereas EcoLight uses the requested output depths, which can be very far apart.** To obtain the needed pairs of closely spaced depths, HydroLight automatically adds another depth just below each output depth requested by the user. Thus if you request output to be saved at depths of 0.0, 1.0, 5.0, and 10.0 m, HydroLight will actually save output at depths of 0.0, 0.01, 1.0, 1.01, 5.0, 5.01, 10.0, and 10.01 m. (In this example, the last depth will be at 10.01 m if the water is infinitely deep. If the bottom is finite depth at 10.0 m, the extra depth will be placed at 9.99 m.) The closely spaced pairs of depths used by HydroLight to compute the  $K$  functions are then  $[z_1, z_2] = [0.0, 0.01], [1.0, 1.01], [5.0, 5.01],$  and  $[10.0, 10.01]$ . These extra output depths are used only for computing  $K$  functions; the remainder of the output is given only at the requested depths. **The HydroLight-computed  $K$ 's are then accurate approximations of the local values of  $K$  at at depth  $(z_2 - z_1)/2$ , for each pair of closely spaced depths.**

Ecolight, however, does *not* add extra depths near the requested output depths. It uses only the requested output depths to compute  $K$  functions as finite differences. In the above example, Ecolight uses the depth pairs  $[z_1, z_2] = [0.0, 1.0], [1.0, 5.0],$  and  $[5.0, 10.0]$ . **The**

**EcoLight-computed  $K$  functions are thus layer-averaged  $K$ 's for each layer  $z_1$  to  $z_2$ .** This convention can cause confusion if you try to compare  $K$ 's computed by HydroLight with those computed by EcoLight. The  $K$ 's can be nearly the same or significantly different, depending on how far apart the requested output depths are. The printout always shows the actual depths used to compute each  $K$  value.

There is also a subtlety in determining the depth where the bottom boundary condition is applied when the water column is infinitely deep and the run includes internal sources or inelastic scatter. This is discussed in §3.3 of the Technical Documentation, and in detail in HydroLight Technical Note 6 (see the HE5\documents directory or the Users' Group website). This situation is automatically handled in HE5 when the default option ALLOW DYNAMIC LOWER BOUNDARY DEPTH is selected on the CHANGE DEFAULTS form.

## 5.8 Output and Run Options

**The FINAL form.** All of the input required to solve the RTE has now been obtained, and the corresponding files required for the run have been saved in various directories. You now have several options.

If you wish, you can use CHANGE OUTPUT OPTIONS to change the amount and type of output to be generated by the run. If you check the CLICK HERE TO SAVE THIS UI INPUT box, the input you have just entered in the UI will be saved and will become the default values for the various forms the next time you run the UI. This will minimize the input required, if the next run is similar to the one now being made.

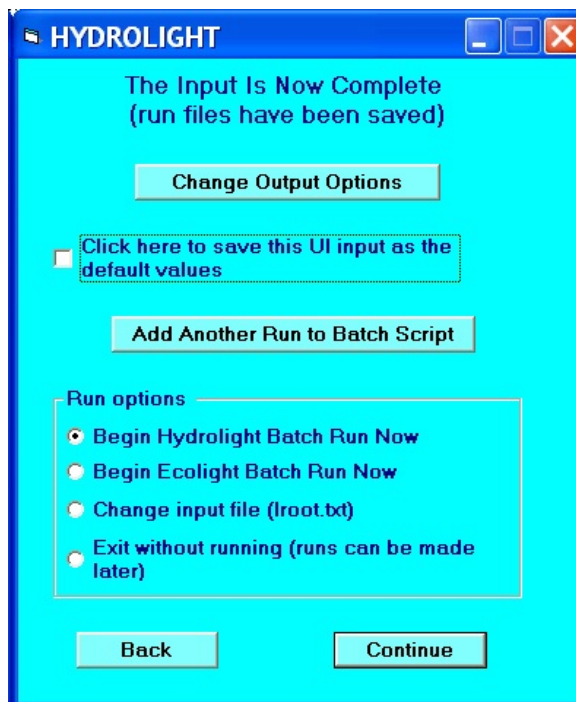

If you wish to define and add another run to this batch, click the ADD ANOTHER RUN button. You will then pass through the UI again to specify the inputs for the next run. You can “stack up” any number of runs, which will then be made one after the other by a single execution of HydroLight or EcoLight.

Once you are done defining the run inputs, the normal procedure is to select whether to run HydroLight or EcoLight with the inputs just created. When you then click on CONTINUE, a command window (shown below) will be spawned and either HydroLight or EcoLight will (recompile if necessary and) run in that window. After the command window is spawned, HE5 is running independently of the UI. You can then click on DEFINE A NEW BATCH RUN and begin entering the input for the next HE5 run. Note, however, that **the next run should not be started until the present run has finished**. (You can, if you wish, run HydroLight and then run EcoLight using the same inputs. This is of interest only if you wish to compare the two types of outputs or compare their run times for the same problem.)

The Iroot.txt input file generated by the UI also can be viewed and edited to change some of the run inputs before the run is made; this feature should only be used by advanced users who are familiar with the format of the input file (described in the Appendix A of the Technical Documentation). Changes to the input file cannot be stored into the UI default values.

**The OUTPUT OPTIONS form.** If CHANGE OUTPUT OPTIONS is selected on the FINAL form, a screen will appear giving the user several options for selecting the type and amount of output generated from a run. These values are stored as defaults and will persist for all future runs until they are changed by the user. These settings will only be stored for future runs if SAVE THIS UI INPUT AS DEFAULT is selected **after** these settings are selected. Note that the Droot.txt and Lroot.txt output files can be quite large if there are many wavelengths and output depths, so do not create these files unless you intend to use them. Likewise, if you do not intend to look at your output using Excel, you do not need to create those output files.

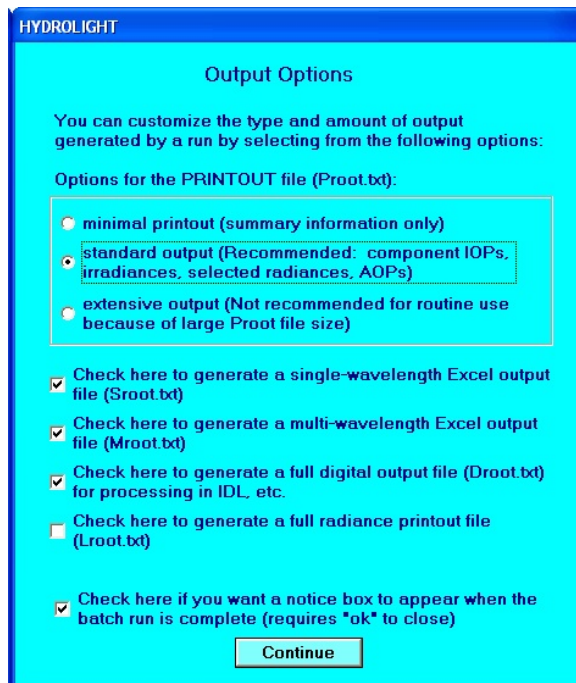

```
C:\WINDOWS\system32\cmd.exe
C:\HE5_test\HE5\Code>echo off

=====
HYDROLIGHT Version 5.0 <MAIN CODE>
Copyright (c) 1992 by Curtis D. Mobley

This copy of HE5 is licensed solely to
Curtis D. Mobley

S/N 00000

THIS PROGRAM IS EXPERIMENTAL AND IS LICENSED "AS IS"
WITHOUT REPRESENTATION OF WARRANTY OF ANY KIND,
EITHER EXPRESS OR IMPLIED. THE ENTIRE RISK AS TO
THE QUALITY AND PERFORMANCE OF HYDROLIGHT IS WITH
THE USER. HYDROLIGHT IS NOT FAULT TOLERANT.
=====

HYDROLIGHT IS RUNNING, PLEASE WAIT...
<To stop the run before normal termination,
kill this command window. Output will be lost>

Run started on 05/16/2008 at 12:36:52.9

Initialization of Hydrolight Completed in 0.5 sec.
Now beginning wavelength 1 of 15 at nominal wavelength 410.0 nm
Waveband 1 of 15 completed in 8.1 sec.
Now beginning wavelength 2 of 15 at nominal wavelength 430.0 nm
Waveband 2 of 15 completed in 7.8 sec.
Now beginning wavelength 3 of 15 at nominal wavelength 450.0 nm
Waveband 3 of 15 completed in 7.6 sec.
```

An example command window showing that HydroLight has recompiled, linked, and is running. Time stamps provide a progress report for the run.

## 6. EXAMPLE HE5 RUNS

This section briefly describes several example HE5 runs. The input and output files for these examples are all found on the HE5\examples directory. You can reproduce these runs on your own computer and compare your output with that from the example runs to verify that HE5 is performing correctly on your computer. The example runs were all made on a 2 GHz Pentium 4 processor. Run times (shown in the printout) on your computer will be longer or shorter, depending on the speed of your computer. (Note also that the “run time” given in the printout is “wall clock” time, not true computation time. Therefore, identical runs may show different run times in the printout, if the computer also was performing other tasks while HE5 was running.) The output from your runs should be identical to that from the examples to within numerical roundoff errors, which may cause very slight differences in some output values. All of the input and output files for these example runs can be found in the HE5\examples directory.

### 6.1: Example 1: A Simple Radiative Transfer Simulation

This tutorial will walk you through your first run of HE5. Each run is specified by only one file: The input `lroot.txt` file (named `IUGEx1.txt`, in this example, which can be found in the HE5\examples\.\Example1 directory). If user-defined subroutines or functions had been included, an additional file, `root.for` (`UGEx1.for` if such were included in this run) would also be written into the HE5\code\batch directory. The various input and output files for this run can be found in the HE5\examples directory.

This example illustrates running HE5 in a manner that is often used in idealized radiative transfer studies. This example solves the monochromatic RTE for a homogeneous, infinitely deep water body. For pedagogic purposes, suppose that we wish to define the inherent optical properties of the water body by the phase function and the albedo of single scattering,  $\omega_o = b/c$ . Here  $c = a + b$  is the beam attenuation coefficient. We shall use  $\omega_o = 0.75$  along with a  $b_b/b$  ratio of 0.023 (2.3% backscatter fraction). The output will be requested at various optical depths  $\zeta$ , as is customary in radiative transfer studies.

To begin, double-click on the HE5 icon on your desktop that you made during installation (or double click `HE5WinUI.exe` in the HE5\frontend directory). To make sure you have a “clean slate” click the RESET defaults button on the first screen. You will need to read the license agreement and understand the disclaimer before you can CONTINUE.

The next screen you see will be the Run Identification screen. For this example, the root name is UGEx1 (for User's Guide Example 1). After entering a root name and run title, click CONTINUE. A screen will pop up showing you the names for the various output files. Note that the name is always made by adding a letter to the front of the selected rootname. Click OK.

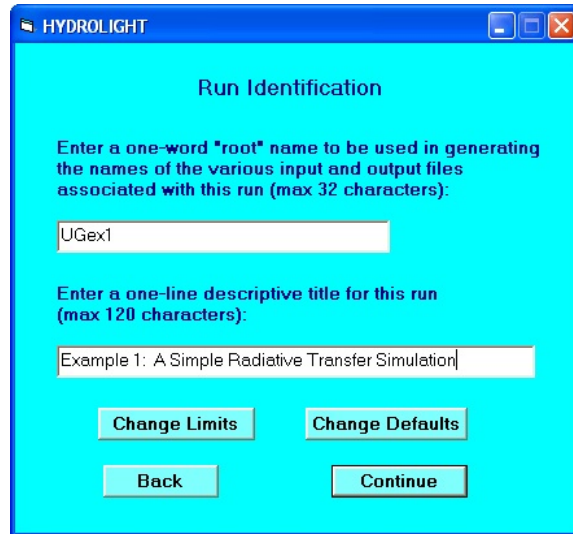

This run is made by selecting the constant IOP model. Select CONSTANT and press CONTINUE. You will not get the message box described earlier reminding you that you have “changed your IOP model” and will need to check your options carefully. Hit CONTINUE.

Next, you will get a screen asking you to specify the IOPs for this run. The input for this model needs  $a$  and  $b$ , not  $\omega_0$ . However, we can use *any* values for  $a$  and  $b$  that give the desired value for  $\omega_0$ , because we are requesting the output as a function of optical depth. The actual values of  $a$  and  $b$  are relevant only if we wish to convert optical depth to geometric depth via  $z = \zeta/(a + b)$ . Therefore, let us use  $a = 0.1 \text{ m}^{-1}$  and  $b = 0.3 \text{ m}^{-1}$ , which give  $\omega_0 = 0.3/(0.1 + 0.3) = 0.75$ , as desired.

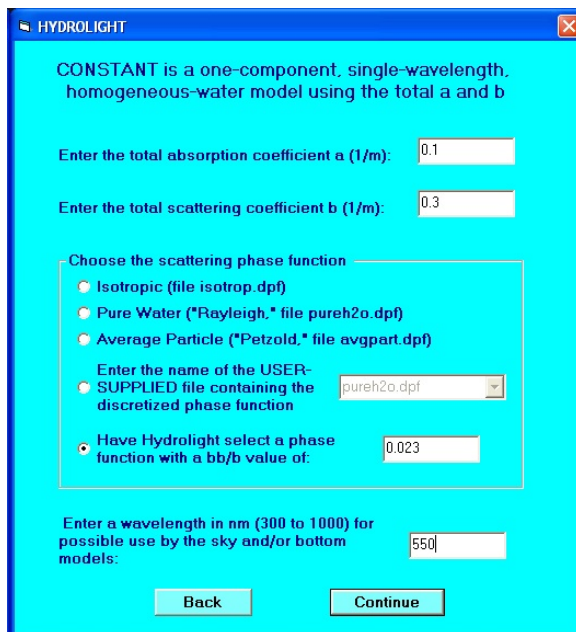

The desired phase function will be selected by HE5 to have a  $b_p/b$  ratio 0.023. Since this model can only be run in a single-wavelength mode, we can specify our wavelength here to be 550 nm (may be used by sky model or if we use a spectrally-dependent bottom reflectance). Hit CONTINUE.

The next form gives the opportunity to include bioluminescence in this run. Note that the various types of inelastic scattering are “greyed out” because they require a multi-wavelength run, and we are solving a monochromatic case. Do not include bioluminescence and hit CONTINUE.

For this example run select a level surface (wind speed = 0 m s<sup>-1</sup>). The wind speed is displayed in three units of measure. You do not need to click UPDATE every time you change the wind speed. The wind speed is converted to m s<sup>-1</sup> (if needed) and the values updated when you leave this form. Use the constant index of refraction set to 1.34 and select the IDEALIZED SKY MODEL. Hit CONTINUE.

Select a uniform sky with a total downwelling irradiance  $E_d$  of 1.0 W m<sup>-2</sup> nm<sup>-1</sup>, the sun at a 30 degree zenith angle, and a uniform background sky with a diffuse-to-direct irradiance ratio of 0.30. Click CONTINUE.

On the next form (not shown here), select the water to be infinitely-deep. Hit CONTINUE.



For this run we will solve the monochromatic RTE to  $\zeta = 15$  optical depths with irregularly-spaced output depths. Since we want to solve our problem in terms of non-dimensional optical depth rather than geometric depth (in meters), select the depths units to be optical depths at the bottom of the form. This option is only available with monochromatic runs. Hit CONTINUE.

We have now provided HE5 with all the information it needs to make the run. On the final form (not shown) you can choose to save your input for future runs. For instance, you might want to process several data files or vary some parameters

to study their effects. You can also view and change your printout options. Select the RUN HYDROLIGHT NOW option on the final form and click CONTINUE.

A command window opens when HE5 begins running. Once the command window appears, you are free to return to the ID form of the UI and begin specifying your next run. However, **do not begin executing** (by selecting RUN ... NOW on the final form) **your next run until the previous run has finished**. If you select RUN ECOLIGHT NOW (it is not necessary to pass through the UI again), you can repeat the same run using the much faster EcoLight code and compare the HydroLight and EcoLight outputs.

As an example of the type of output that can be obtained from HE5, Fig. 7 shows how various  $K$  functions approach the asymptotic value  $K_\infty$ . This plot was generated by the IDL routine HE5UG\_Fig7.pro, which is found in the HE5\examples\IDL directory. Routine HE5UG\_Fig7.pro reads the HydroLight digital output file Dugex1.txt (in the HE5\output\Hydrolight\digital directory) as input. Because this run was made in terms of optical depth, the  $K$  functions have been plotted as non-dimensional quantities:  $K(\text{non-dimen}) = K(\text{dimen})/c$ ; see Note 3 below. Note that the values in Fig. 7 are local estimates of the  $K$ 's, which were computed from closely spaced pairs of depths, as explained in § 5.7. The various

$K$ 's differ near the sea surface because of surface boundary effects, but they all approach the same asymptotic value  $K_\infty$  as the depth increases.

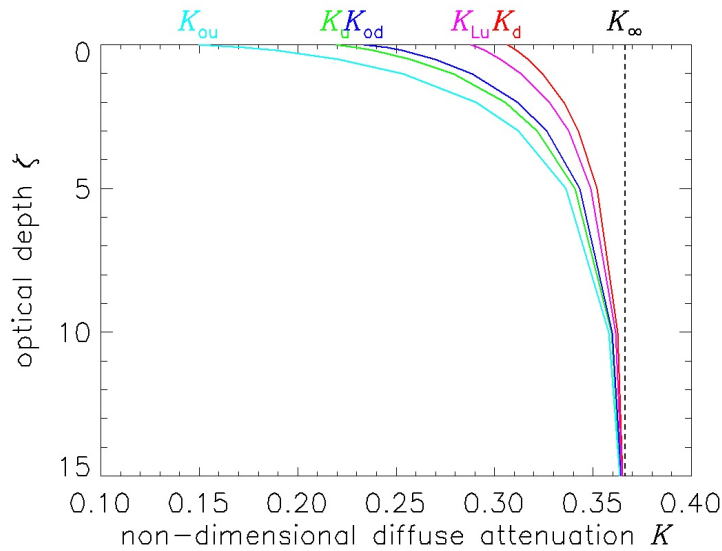

Fig. 7. Selected non-dimensional diffuse attenuation functions, as computed by the HydroLight run for Example 1. (Figure plotted by the IDL routine on HE5\examples\IDL\HE5UG\_Fig7.pro.)

**Note 1.** The abconst IOP model is for runs at a single wavelength, which was taken to be 550 nm. However, the wavelength is irrelevant in this run, because the run used the idealized sky model and had infinitely deep water. Had the run used the semi-empirical sky model or had it used a finite-depth bottom with a wavelength-dependent bottom reflectance, the wavelength would have been needed to obtain the sky or bottom information at a the run wavelength. Because the run was at a single wavelength, there was no option of including inelastic-scattering.

**Note 2.** For the values of  $a = 0.1 \text{ m}^{-1}$  and  $b = 0.3 \text{ m}^{-1}$  used in this run, 15 optical depths corresponds to  $15/c = 37.5 \text{ m}$  of geometric depth. If you make another run with, say,  $a = 1.0 \text{ m}^{-1}$  and  $b = 3.0 \text{ m}^{-1}$  (and all else the same), you will find that the radiances and irradiances are all the same as a function of optical depth, even though 15 optical depths is then 3.75 m. Moreover, the run times will be the same, because it is optical depth that matters in the solution of the RTE.

**Note 3.** Even though the run saved its output at the specified optical depths, the  $K$  functions in the default printout were computed using geometric-depth derivatives; the  $K$  functions therefore have units of inverse meters, as is customary. If you want non-dimensional  $K$  functions computed with optical-depth derivatives, you can multiply the values in the printout by  $1/c$  ( $= 2.5$  m in the present case). Routine `HE5\code\HydroLight\kfcn.f`, which computes the  $K$  functions for HydroLight, also has the option of printing out a table of non-dimensional  $K$  functions. Note also that the dimensional  $K$  functions will be different for the  $(a, b) = (0.1, 0.3)$  and  $(1, 3)$  runs even though the non-dimensional  $K$  functions (computed using optical-depth derivatives) are the same at corresponding optical depths.

## 6.2: Example 2: A Simulation of Case 1 water with the Classic IOP Model

Now that you have made your first run of HE5, let's consider a multi-spectral Case 1 water simulation. The various input and output files for this run can be found in the `HE5\examples\..\Example2` directory. In this case, the root name for this run is `UGEx2`. After you have entered the root name and a run title, hit `CONTINUE`. When the informative page pops up listing the various file names for this run, hit `CONTINUE`.

Once you get to the model selection screen, select `CLASSIC CASE1`—the “Gordon-Morel” Case 1 water model. You can use the tab button to scroll through the model options and to reach the `CONTINUE` button if you like. Hit `CONTINUE`. You will now get the message box described earlier reminding you that you have “changed your IOP model” and will need to check your options carefully. Hit `CONTINUE`.

Next, you will see a form briefly telling you about the components included in the model you have selected. Click the `SPECIFY COMPONENT IOPS` button.

The first IOP specification form will appear next for pure water (your first component). There's not a lot to look at on this form since you don't need to worry about a water concentration, phase function, or scattering coefficient. You do need to specify the pure water absorption values you would like to use by clicking on the `SPECIFY PURE WATER ABSORPTION` button. You have three options for specifying pure water absorption: you can use

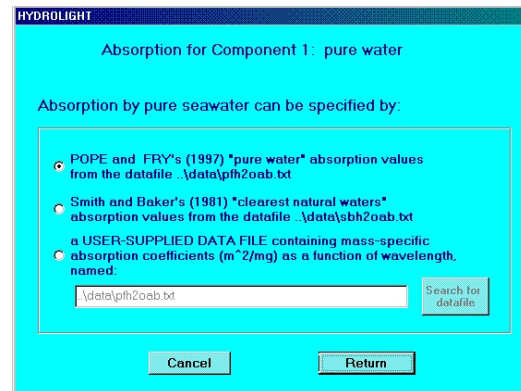

Pope and Fry's data, Smith and Baker's data, or select your own data file. Select Pope and Fry and click RETURN. You will be returned to the Pure Water specification page. Hit CONTINUE.

For the second component, chlorophyll-bearing particles, you will need to specify the concentration profile and the phase function. Click on the SEARCH FOR DATAFILE button and browse until you find the file chlzdata.txt in the Examples subdirectory (or the Data directory in the HE5 folder).

Next you need to specify the phase function for this component. Select the data file option and use the pulldown menu to select Petzold's average-particle phase function file, avgpart.dpf. Hit CONTINUE. A notice will appear informing you that the the data file chlzdata.txt will be read.

HYDROLIGHT  
IOP specification for Component 2: chlorophyll

Concentration profile

to be CONSTANT with depth, with a value of: 0

by a STANDARD FORMAT USER-SUPPLIED DATA FILE named: C:\HE5\data\examples\Chlzdata.txt

by a USER-SUPPLIED SUBROUTINE named:

Phase function

Enter the name of the USER-SUPPLIED file containing the discretized phase function avgpart.dpf

Select a phase function with a bb/b value of: 0

Select a phase function with a bb/b value specified by a power law

Next, you will need to decide whether to include any inelastic scattering (fluorescence) or sources in the run. Check the chlorophyll fluorescence and Raman scattering boxes. Then hit CONTINUE.

Note that if you had decided to include bioluminescence, you would have been prompted to provide information on the bioluminescence by an additional form. If you had included CDOM fluorescence, the absorption of CDOM will be apportioned based on the bio-optical model and a set fluorescence efficiency will be applied.

A notice will appear telling you where HE5 plans on getting information on the component concentrations needed for the chlorophyll fluorescence. As the notice says, remember to always include the relevant excitation wavelengths if you want to include inelastic scattering in a run.

Next, we need to select the wavebands for the run. Since we have selected fluorescence and inelastic scattering we are not allowed to select the single-wavelength option, nor can we choose to skip every other wavelength band. For this run, select the “min/max/interval” option and set the run to go from 350 nm to 700 nm with 10 nm wide bands. Hit CONTINUE.

Set the wind speed to 2 m/s. Click the UPDATE button to see how many knots this is. Select the option to let the index of refraction vary with wavelength with a temperature of 20C and salinity of 35ppt. Since we are making a multi-wavelength run, we must use the semi-empirical sky model. Press CONTINUE.

For this run, set the sky conditions so that the sun has a zenith angle of 20 degrees and we have 30% cloud cover. You can view (and change) the atmospheric parameters—but leave them at their preset values for this run. Press CONTINUE.

We will use RADTRAN-X to calculate the irradiance for our given atmosphere and sky conditions and use the Harrison and Coombes normalized sky radiance model to specify the distribution of sky radiance (by selecting the subroutine hcnrad, which is the only option in the distributed code). Use the annual average earth-sun distance on the next form (not shown). After selecting these options, click CONTINUE.

To specify the bottom boundary condition, select the finite depth bottom condition option and set the bottom reflectance to be 20%, independent of wavelength (an approximation for “gray mud”). Click CONTINUE.

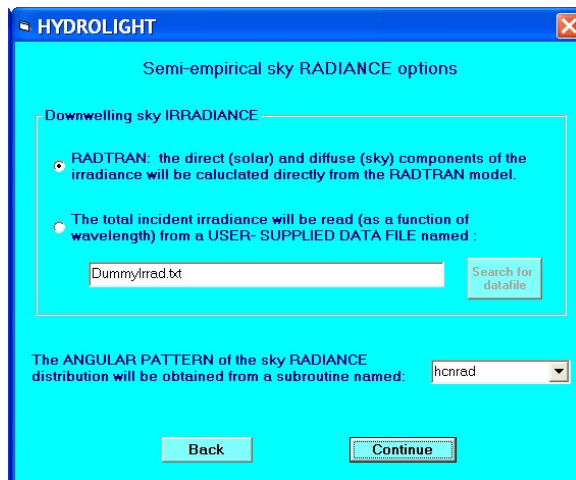
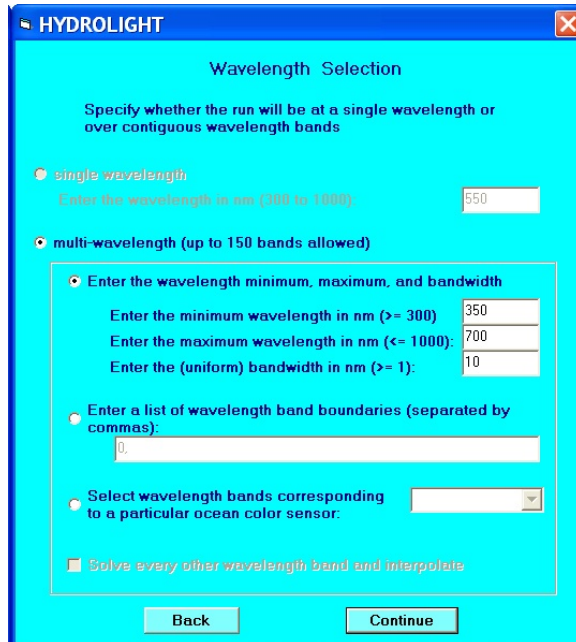

The sea floor will be placed at the maximum output depth selected on this form. If we had selected an infinitely-deep bottom, the IOPs below this depth would be assumed constant with the value at this depth. Select a maximum depth of 20 meters with output every 2 meters. We must use geometric depths since we are making a multi-wavelength run. Don't forget that the accuracy of the calculations will not be affected by the number or locations of output depths.

We now arrive at the same final form as before, having provided HE5 with all the information it needs to solve the RTE. The run is completely specified by the input file (IUGEx2.txt). Select the `BEGIN HYDROLIGHT BATCH RUN NOW` option and click `CONTINUE`. After the HydroLight run completes, select the `BEGIN ECOLIGHT BATCH RUN NOW` option and repeat the same run for comparison of HydroLight and EcoLight outputs. These runs took 144 seconds for HydroLight and 4.5 seconds for EcoLight on a 2 GHz PC.

Figure 8 shows both the HydroLight- and the EcoLight-computed nadir-viewing remote-sensing reflectances  $R_{rs} = L_w/E_d$  (where  $L_w$  is the water-leaving radiance, i.e., the total radiance minus the reflected sky radiance; and  $E_d$  is evaluated just above the water surface). The red line shows the  $R_{rs}$  computed by HydroLight; the blue dots show the values computed by EcoLight. The two models give the same  $R_{rs}$  to within 3% (the differences are due to numerical differences in the algorithms used to solve the RTE). Since EcoLight ran 32 times faster than HydroLight, it clearly makes sense to run EcoLight if the only output needed is the nadir-viewing  $R_{rs}$  or a similar quantity such as an irradiance, for which the two models give essentially the same output. HydroLight needs to be run only for output that depends on the full radiance distribution or on the azimuthal dependence of the radiance. An example of such output is the off-nadir remote-sensing reflectance. In this example,  $R_{rs}$  is greatest at near-UV and blue wavelengths, which is expected for Case 1 water with a chlorophyll concentration of approximately  $0.5 \text{ mg/m}^3$ . Note that HE5 computes the water-leaving and reflected-sky radiances separately, so the remote-sensing reflectance shown here is exact, not an approximation obtained via any semi-empirical correction for reflected-sky radiance or for transmitted upwelling radiance from below the surface.

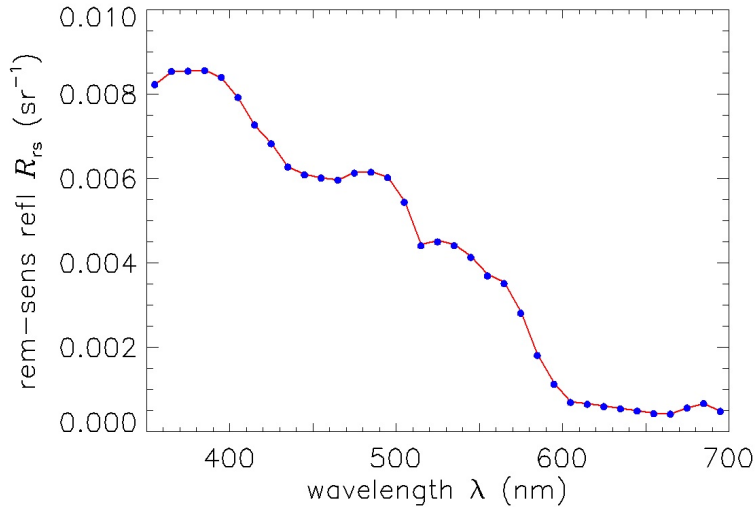

Fig. 8. The remote-sensing reflectance as a function of wavelength for the CLASSICCASE 1 water of Example 2. The red line was computed by HydroLight, the blue dots were computed by EcoLight. (Figure plotted by the IDL routine on HE5\examples\IDL\HE5UG\_Fig8.pro.)

### 6.3: Example 3: A Simulation of Case 1 water with the NEW CASE 1 IOP Model

Some features of the Classic Case 1 IOP model are over 20 years old and do not account for recent advances in optical oceanography. HE5 therefore contains a new Case 1 IOP model based on recently published bio-optical models. The new model is described in detail in the §2.4 of the Technical Document. For this example, we will select the NEW Case 1 IOP model but otherwise keep everything the same as in the previous example. Select the “medium UV Chlorophyll specific absorption” option (only affects wavelengths < 400nm). Note that now the phase function is automatically determined based on the ratio of small to large particles, which is a function of the chlorophyll concentration. Figure 9 shows the resulting HydroLight remote-sensing reflectance  $R_{rs}$  for the classic Case 1 IOP model (red, redrawn from Fig. 8) along with the HydroLight  $R_{rs}$  for the new Case 1 IOP model (blue). The differences show how these two different IOP models for Case 1 water can generate significantly different light fields. In this simulation,  $R_{rs}$  is less for the new Case 1 IOP model primarily because the particle backscatter ratio is less than the value of 0.023 used in the classic model.

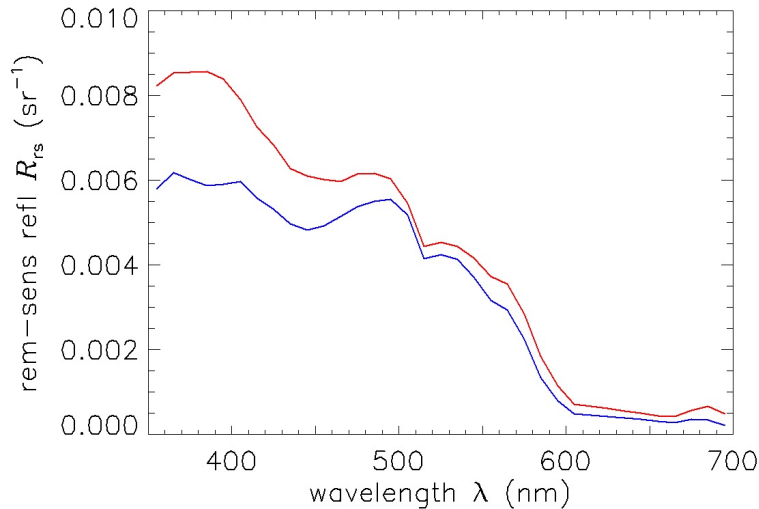

Fig. 9. Remote-sensing reflectances for the classic (red) and new (blue) IOP models for Case 1 water. (Figure plotted by the IDL routine on HE5\examples\IDL\HE5UG\_Fig9.pro.)

#### 6.4: Example 4: A Simulation of Case 2 Water

As a more complicated example of running HE5, consider a simulation the light field in shallow Case 2 water. The water was modeled as a four-component system:

- Component 1: pure water
- Component 2: chlorophyll-bearing particles (with no co-varying yellow matter)
- Component 3: CDOM (yellow matter) that does *not* covary with the chlorophyll concentration
- Component 4: mineral particles that do *not* covary with the other components.

The corresponding IOP routine is found on file HE5\code\common\abcas2.f. Since several methods of specifying concentration and component IOP models are available, this IOP routine provides a good starting place for studying Case 2 water. Also, `abcas2.f` can be used as a template for users to develop their own multi-component models (see Technical Documentation for instructions on developing code for new IOP models).

To make this run, start HE5 as before, provide a root name and run title and select the CASE2 option from the IOP model form. After you see the form reminding you about the four components in this model, you will be taken through a set of forms to specify the IOPs for each



of the four components. There is considerable freedom in specifying IOPs with the Case 2 water model, and you therefore will find that more information is requested by the UI. Going through the forms, specify the components as follows:

- **Component 1: pure water**

For pure water you will need to specify the pure water absorption and the phase function. For the absorption, select the Pope and Fry option as before. The pureh2o.dpf scattering phase function will be used automatically.

- **Component 2: chlorophyll-bearing particles**

For Component 2 you need to specify the concentration, chlorophyll-specific absorption and scattering models, and the scattering phase function. In this example, the concentration will be obtained from a subroutine named chlzfuncEx4 on file chlzfuncEx4.f **This is an example of a user-supplied subroutine. User-supplied subroutines MUST be placed in the HE5\code\user directory.** This example routine is already placed there in the distributed code, for use in this example run. Select the option for a user-supplied subroutine for the chlorophyll concentration and enter the name of this routine in the box. Select a backscatter fraction of 0.005, which is appropriate for phytoplankton. A Fournier-Forand phase function with a  $b_b/b$  ratio of 0.005, or 0.5% backscatter, will then be used.

As you can see by looking at the subroutine on file HE5\code\user\chlzfuncEx4.f, the chlorophyll value is defined by a background value plus a Gaussian function of depth, with the maximum value at a depth of 5 m. For the 8 m water depth chosen below, the chlorophyll concentration varies from 0.61 mg m<sup>-3</sup> at the surface to 3.00 mg m<sup>-3</sup> at  $z = 5$  m, and then decreases to 1.31 mg m<sup>-3</sup> at  $z = 8$  m.

On the SPECIFY ABSORPTION form for the chlorophyll component, select the “chlorophyll-based Case 1 water model” for absorption. On the SPECIFY SCATTERING form, select the linear scattering model with the default values (hit the USE GAM MODEL PARAMS button) and set  $b_0$  to 0.30.

**HYDROLIGHT**  
Scattering Specification for Component 2: chlorophyll

Scattering (in terms of concentration X)

- a USER-SUPPLIED DATA FILE containing mass-specific scattering coefficients ( $m^2/mg$ ) as a function of wavelength, named:
- a power law:  $b(\lambda) = b_0 X^n \left(\frac{\lambda_0}{\lambda}\right)^m$ 
  - for b
  - for c (b will be calculated as c - a)
- a linear relation:  $b(\lambda) = b_0 X^n \left(\frac{m\lambda + i}{m\lambda_0 + i}\right)$ 
  - $b_0$       $\lambda_0$       $n$
  - $m$
  - $b_0$       $\lambda_0$       $n$
  - $m$       $i$
- a wavelength-independent mass-specific scattering coefficient ( $m^2/mg$ ) with the value:

● **Component 3: CDOM**

In this run, CDOM absorption will be provided as a function of depth and wavelength by a user-supplied subroutine named aCDOM in file code\user\acdomEx4.f. Enter the name acdomEx4 in the box as shown on the CDOM component form.

The depth and wavelength functions in file HE5\code\user\acdomEx4.f define the CDOM absorption coefficient  $a_{CDOM}(z, \lambda)$ . At 440 nm, the absorption by CDOM is  $0.1 m^{-1}$  at the surface; this value decreases exponentially to  $0.02 m^{-1}$  at 8 m (to crudely simulate a near-surface layer of CDOM as might arise from river input). The CDOM absorption decreases exponentially with wavelength; it is negligible at red wavelengths, but was triple the above values at 350 nm. **As with the chlfuncEx4 subroutine, acdomEx4 is just an example of how to write a user-supplied subroutine; it is not intended for general use.**

**HYDROLIGHT**  
IOP specification for Component 3: CDOM

The depth dependence of the CDOM absorption at a reference wavelength can be specified:

- to be CONSTANT with depth, with a value of:
- by a STANDARD FORMAT USER-SUPPLIED DATA FILE named:

The wavelength dependence of the CDOM absorption must be specified by the specific absorption,  $a^*$ .

- Absorption by CDOM (as a function of depth and wavelength) will be provided by a SUBROUTINE named:
- Absorption by CDOM will be set to be proportional to chlorophyll absorption at a reference wavelength:
  - where:  $a_{CDOM}(z, \lambda) = F a_{chl}(z, \lambda_0) \exp[-\gamma(\lambda - \lambda_0)]$
  - $F = 0.2$      $\lambda_0 = 440$      $\gamma = 0.014$

CDOM is assumed to be non-scattering.

Note that there is an option (not chosen here) to select CDOM to covary with chlorophyll with the form of the Prieur-Sathyendranath-Morel Case 1 water model. This covarying CDOM is automatically included in the ABCASE1 model of the second example, but ABCASE2 explicitly separates the chlorophyll and CDOM components and allows the user to define each IOP component independently of the others.

● **Component 4: minerals**

The minerals in this run will be modeled as red clay particles. The concentration will be provided by the data file minzdataEx4.txt in the HE5\data\Examples\ directory, which crudely simulates a layer of resuspended sediment. The mineral concentration on this data file varies from 0.1 gm m<sup>-3</sup> at the surface to 1.0 gm m<sup>-3</sup> at 8 m.

The specific absorption and scattering coefficients will be provided by the data files astarmin\_redclay.txt and bstarmin\_redclay.txt, respectively. These files are in the HE5\data\defaults\ directory. Browse for these files on the forms that solicit the absorption and scattering information for the mineral component. Have HE5 choose a mineral particle phase function (Fournier-Forand) with a backscattering ratio of  $b_b/b$  that varies with wavelength according to a power law, as shown on the next form.

Include Raman scattering and fluorescence by chlorophyll and CDOM on the inelastic form. On the wavelengths form, select the wavebands to match those of SeaWiFS. Note that the first SeaWiFS wavelength band is 402-422nm. Raman scatter and CDOM fluorescence are excited by wavelengths shorter than 400nm, so there will be some inaccuracy in the

inelastic-scatter calculations, but this will be a minor effect for this turbid Case 2 water body. Select a wind speed of  $4 \text{ m s}^{-1}$ , a water temperature of 10 deg C, and a salinity of 25 psu, which are typical for Puget Sound, Washington, USA.

Use the “semi-empirical” sky model. Use the time and location options to specify a date of 15 June 2008 (year day 167), 23:00 GMT (mid afternoon in Puget Sound), latitude 48.5 degrees North, and longitude of 123 degrees West (Puget Sound). (The corresponding solar zenith angle, computed during the HE5 run, is  $41.48^\circ$ .) Assume a clear sky (cloud cover value of 0).

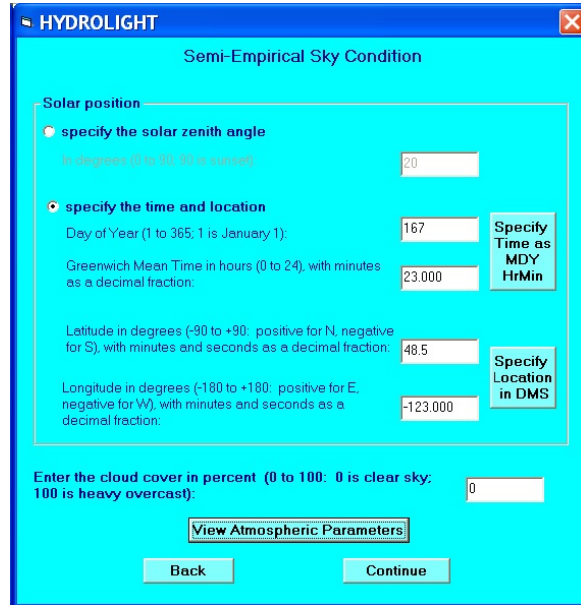

Use VIEW ATMOSPHERIC OPTIONS to set the airmass type to 3 (mixed marine and continental aerosols). Enter the ozone concentration as -99 Dobson units, which will cause the TOMS climatological ozone value for this date and location to be used, as described in §5.1 of the Technical Documentation. (This ozone value is 339.8 Dobson units, as seen in the printout.) Use the defaults for the other atmospheric parameters.

Take the water column to have a finite depth of 8 m with a bottom reflectance for “average sea grass.” Save the output at 0.5 m intervals. This now gives HE5 everything needed to solve the RTE.make this run. On the final form, click the CHANGE OUTPUT OPTIONS button and make sure that the run is creating the Droot.txt and Lroot.txt output files.

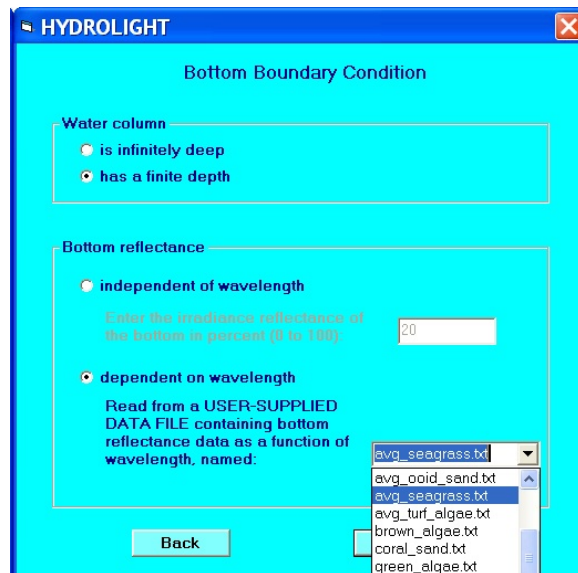

Note that when you hit `BEGIN HYDROLIGHT BATCH RUN NOW`, the code automatically recompiles before running. This recompilation is necessary because the user-supplied subroutines `chlzfunc` and `acdom` must be compiled and included in the executable along with the other HE5 routines. This process incorporates the user routines via a file named, in this example, `UGEx4.for`, which is placed in the `HE5\code\batch` directory. The previous examples did not generate any `*.for` files because there were no user-supplied subroutines.

Inspection of the printout for this run shows that, depending on the depth and wavelength, the total absorption at blue wavelength is dominated by any of phytoplankton, CDOM, or minerals. Absorption by water of course dominates at red wavelengths. Scattering can be dominated by either phytoplankton or minerals, depending on the depth and wavelength; the CDOM was assumed to be non-scattering. This model for  $a$  and  $b$  gave total albedos of single scattering,  $\omega_0$ , that ranged from only 0.14 at 765 nm, where absorption by the water is high, to more than 0.90 at near 570 nm, where the total absorption was lowest. The geometric depth of 8 m corresponded to 8.3 optical depths at 412 nm (where both CDOM absorption and particle scattering were high), to about 6.8 optical depths near 570 nm, to 24.7 optical depths at 765 nm.

This HydroLight run required 87 seconds on a 2 GHz Pentium 4 Processor. It should be noted that the simulation required the solution of the radiative transfer equation for 20 wavelength bands, with three types of inelastic scattering connecting the bands. On average, each wavelength solution was taken to about ten optical depths. Thus the HydroLight run time corresponded to less than five seconds per wavelength per optical depth. The archival printout file `PUGEx4.txt` is less than 0.4 Mbyte, but the digital output file `DUGEx4.txt` (which contains all inputs and outputs at all depths, directions, and wavelengths) is about 6.9 Mbytes, and the `LUGEx4.txt` file (which contains the radiance distribution at all depths, directions, and wavelengths, but on a different format than `DUGEx4.txt`) is 8.6 Mbytes. The corresponding EcoLight run required only 2.8 seconds.

The following figures show some of the input to and output from this simulation. Figure 10 shows selected component and summed IOP's (the sum of phytoplankton, CDOM, and minerals, but not including water) as functions of depth and wavelength. These figures were all plotted using IDL routine on `HE5\examples\IDL\HE5UG_Fig10.pro`, which reads the `DUGEx4.txt` file.) Figure 11 shows plots of the radiance distribution in the plane of the sun's rays as a function of viewing direction and wavelength, at depths of 0, 4, and 8 m. (This figure was generated using IDL routine `HE5UG_Fig11.pro`.)

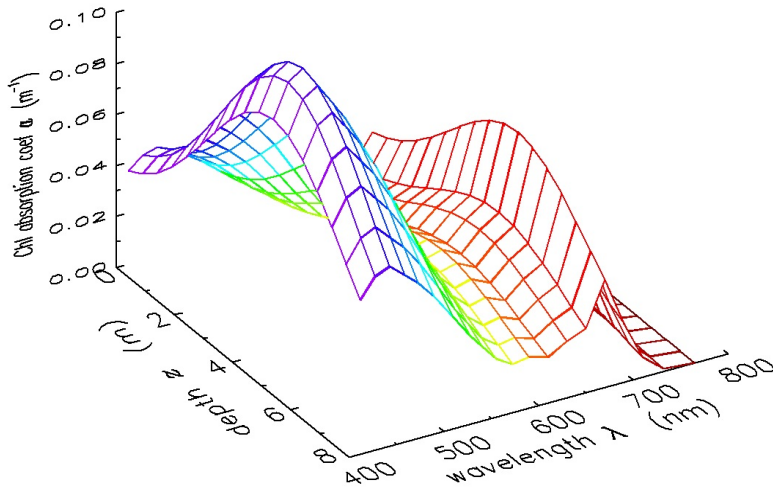

Fig. 10(a). The absorption coefficient for chlorophyll-bearing phytoplankton as function of depth and wavelength, as used in Example 4.

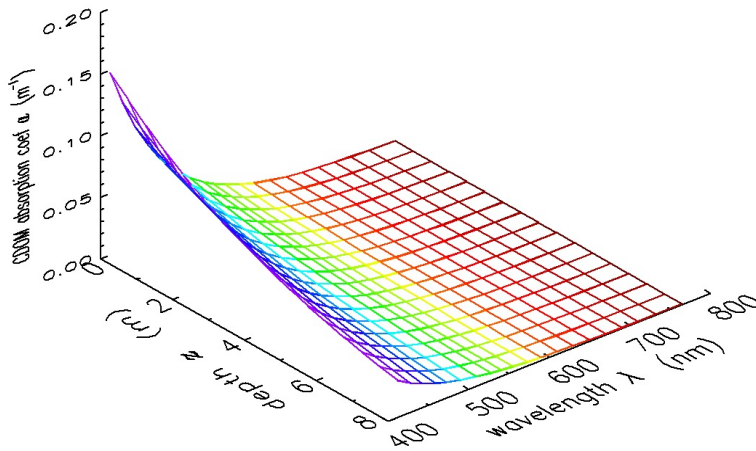

Fig. 10(b). The absorption coefficient for CDOM as function of depth and wavelength, as used in Example 4.

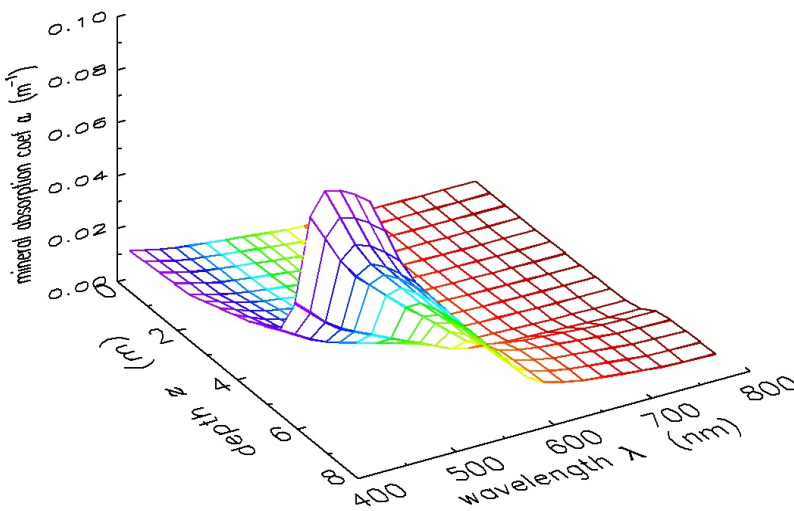

Fig. 10(c). The absorption coefficient for mineral particles as function of depth and wavelength, as used in Example 4.

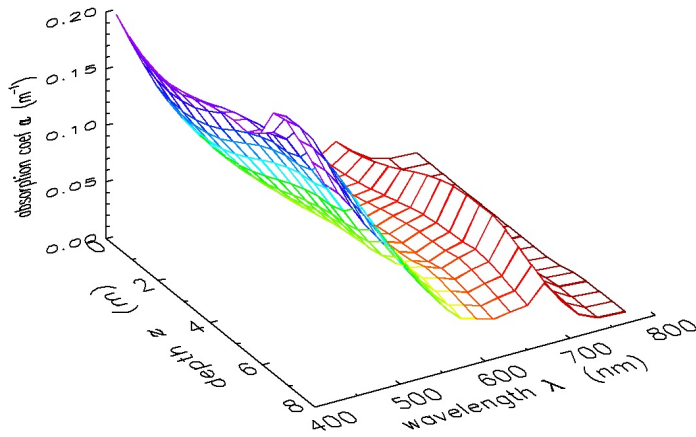

Fig. 10(d). The sum of particle and CDOM absorption (not including water) as a function of depth and wavelength, as used in Example 4.

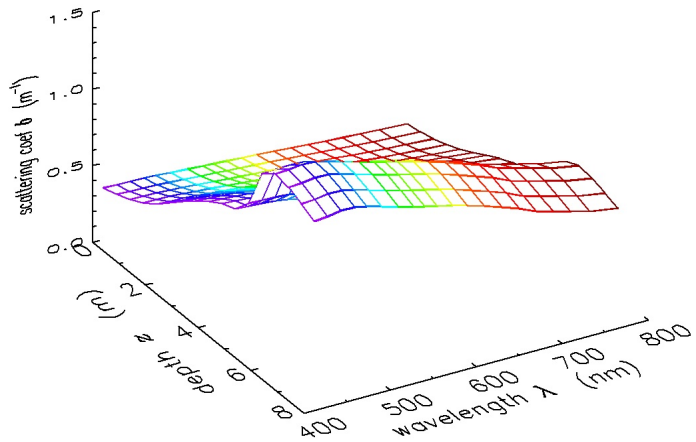

Fig. 10(e). The sum of phytoplankton and mineral particle scattering (not including water) as a function of depth and wavelength, as used in Example 4.

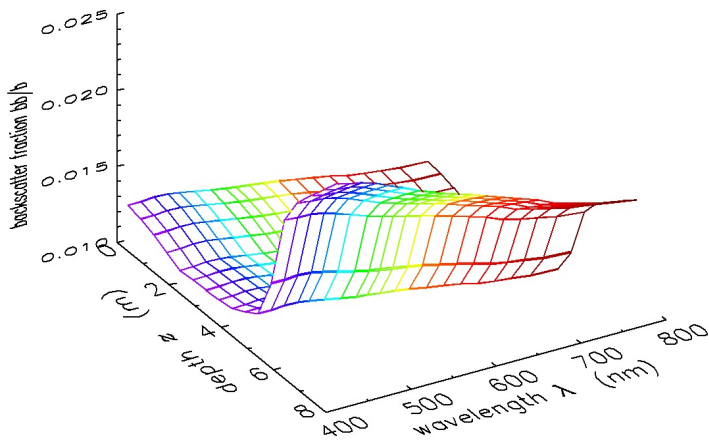

Fig. 10(f). The particle backscatter fraction  $b_b/b$  as a function of depth and wavelength, as used in Example 4.

Figure 11 illustrates how the HydroLight-computed radiance distribution changes with depth, polar angle, azimuthal angle, and wavelength. (This figure was generated using IDL routine HE5UG\_Fig11.pro.) Radiance plots contain a wealth of information, but their interpretation requires care. Although the present Example 4 simulation has a wind speed of  $U = 4$  m/s, let us start with the same simulation (same IOPs, etc.) except for a wind speed of  $U = 0$ , so that the sea surface is level. Figure 11(a) shows the radiance in air (just above the sea surface) as a function of the polar viewing angle and wavelength, in the azimuthal plane of the sun, for  $U = 0$ . To understand this plot, recall from §3.4 that in HydroLight the polar angle is measured from the  $+z$  or downward direction. Thus photons heading straight down have a polar angle of  $\theta = 0$ . This plot uses the *viewing* direction  $(\theta_v, \phi_v)$ , which is the direction an instrument would point when measuring the radiance. Thus the polar viewing angle of  $\theta_v = 0$  means looking straight down and seeing the radiance heading straight up (the nadir-viewing radiance; photons traveling in the  $\theta = 180$  deg direction). The sun is always located at  $\phi = 0$  (recall Fig. 3). This figure shows the full range of polar angles in the  $\phi = 0$ -180 deg plane of the sun. A polar angle of  $\theta_v = +90$  deg corresponds to looking horizontally towards the sun, and  $\theta_v = -90$  deg corresponds to looking horizontally away from the sun. The sun's radiance is the large spike at  $\theta_v = 140$  deg, which corresponds to looking upward ( $\theta_v > 90$  deg) at a zenith angle of 40 deg in the  $\phi = 0$  azimuthal direction, where the sun was located in this simulation. The smaller spike at  $\theta_v = 40$  deg is the sun's specular reflection, seen looking downward ( $\theta_v < 90$  deg) and towards the sun. The ratio of the sun's specular reflectance to the sun's direct beam is 0.026 (computed from the radiance values tabulated in the LUGEx4.txt file), consistent with the Fresnel reflectance for this incidence angle and water index of refraction. The broader radiance peak near  $\theta_v = -90$  deg is the bright near-horizon sky radiance and its reflection by the sea surface, seen looking away from the sun. Figure 22 of the Technical Documentation shows a similar sky radiance distribution plotted in a different way. Note in that figure that the sky radiance increases somewhat near the horizon when looking away from the sun.

Figure 11(b) is the same as Fig. 11(a), except that the wind speed is  $U = 4$  m/s, as selected in the present Example 4 simulation. Note that the sun's specular reflection has been smeared out by the wind-blown sea surface. The other radiance features remain about the same as for the level-surface simulation.



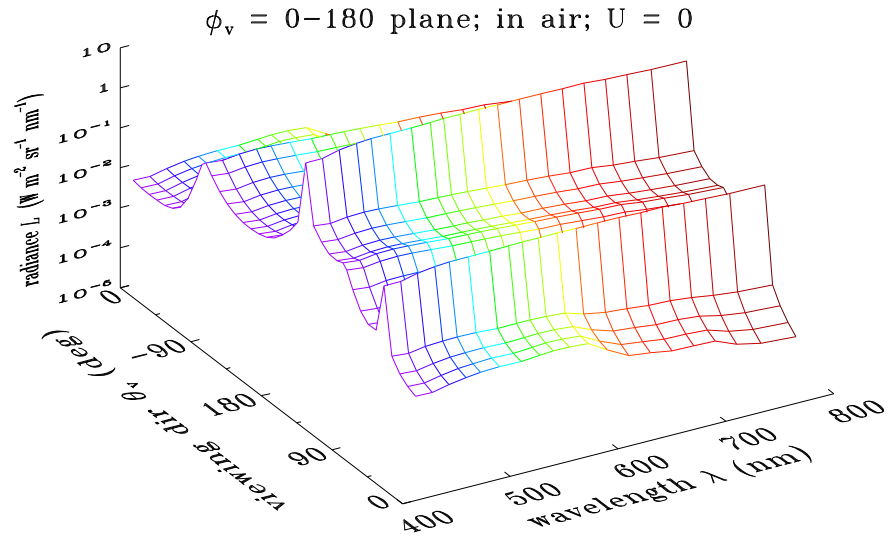

Fig. 11(a). The radiance distribution in the plane of the sun's rays, as a function of viewing direction and wavelength, in air just above the level air-water surface. Note that the radiance axis is logarithmic.

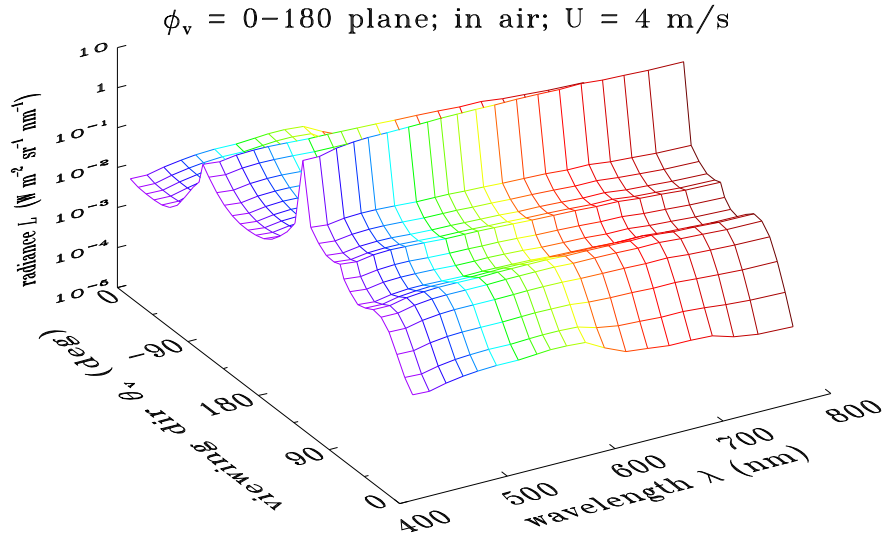

Fig. 11(b). The same as for Fig. 11(a), except that the wind speed is 4 m/s. Note that the sun's specular reflection seen in Fig. 11(a) has been smeared out by the ruffled sea surface.

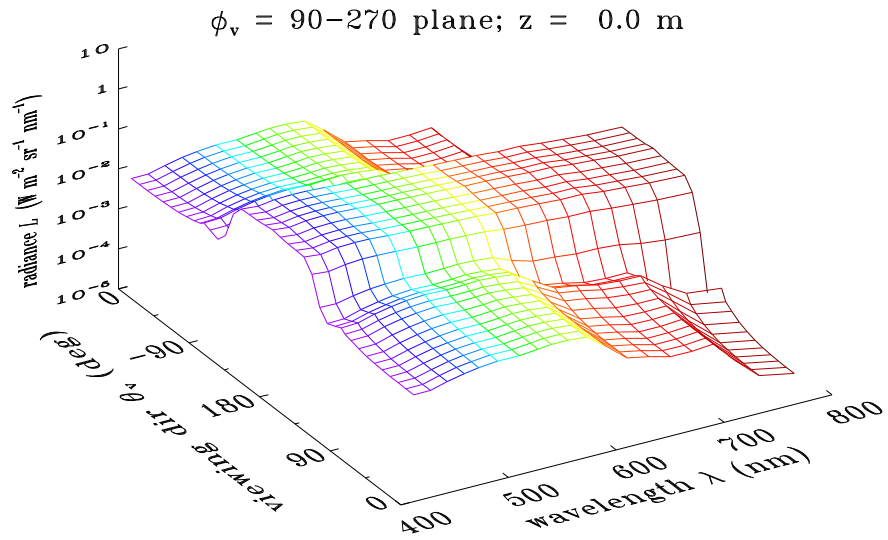

Fig. 11(c). The radiance just below the sea surface, in the plane perpendicular to the sun's azimuthal direction.

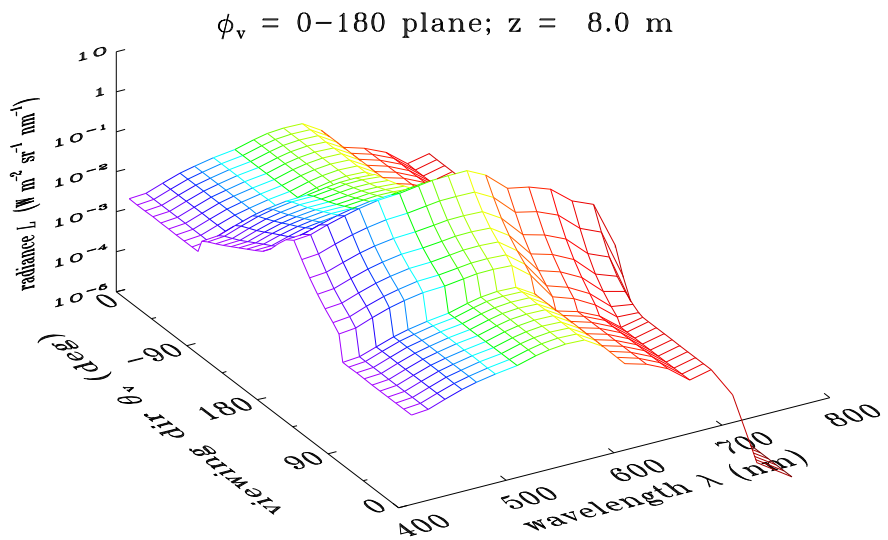

Fig. 11(d). The radiance distribution in the plane of the sun's rays, just above the sea floor at a depth of 8 m. The constant radiance in the upward directions is a consequence of the Lambertian bottom.

Figure 11(c) shows the radiance at depth  $z = 0$ , just below the wind-blown sea surface, and in the azimuthal plane perpendicular to the sun's direction. The radiance is now symmetric about the zenith direction  $\theta_v = 180$  deg. The radiance (mostly transmitted sky radiance) is fairly uniform looking upward in "Snell's window," which extends about 50 deg to either side of the zenith ( $\theta_v = 180$  deg) direction. The small bump in the upwelling radiance near 685 nm is due to chlorophyll fluorescence.

Finally, Fig. 11(d) shows the radiance distribution in the plane of the sun's rays just above the sea floor at a depth of 8 m. The sharp spike of the sun's direct beam seen near the surface has been broadened by multiple scattering and decreased in magnitude by absorption. The constant radiance in the upward directions ( $\theta_v$  between 0 and  $\pm 90$  deg) is a consequence of the Lambertian bottom, which reflects the downwelling radiance equally into all upward directions. The radiance at wavelengths beyond  $\sim 700$  nm has been greatly reduced in magnitude by water absorption.

Figure 12 shows the remote-sensing reflectance  $R_{rs} = L_w/E_d$  (where  $L_w$  is the water-leaving radiance, i.e., the total upwelling radiance in air minus the surface-reflected sky radiance; and  $E_d$  is evaluated just above the water surface).  $R_{rs}$  is greatest near 550 nm, showing that this is "green" Case 2 water. (Compare this with the "blue" water simulation of Example 2, Fig. 8.) The bump at 690 nm shows the effect of chlorophyll fluorescence. The gray bands show the nominal SeaWiFS sensor bands. This simulation chose the SeaWiFS bands on the form for wavelength output. Note that the output includes the SeaWiFS wavelengths as requested, as well as additional wavelengths as needed for the inelastic scatter calculations. As in Fig. 8, the HydroLight-computed  $R_{rs}$  is the red line; the EcoLight-computed values are the blue dots. The agreement between HydroLight and EcoLight is again excellent, and EcoLight ran 31 times faster than HydroLight (2.8 vs 87 seconds, respectively). However, only HydroLight can provide the azimuthal information contained in the full radiance distribution, as seen in the plots of Fig. 11.

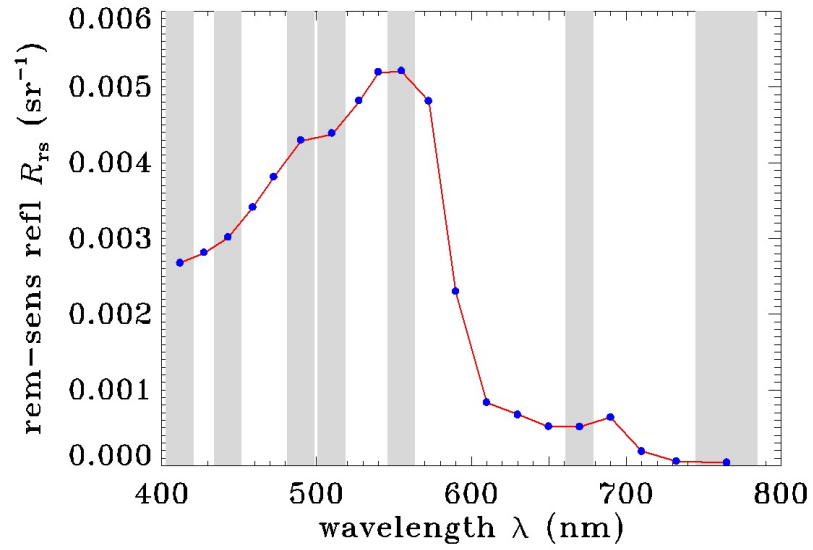

Fig. 12. The remote-sensing reflectance as a function of wavelength for the Case 2 water of Example 4. The gray bars show the nominal SeaWiFS sensor bands. (This figure was generated by IDL routine HE5UG\_Fig8.pro.)

## 7. OUTPUT FROM STANDARD RUNS

The examples just discussed showed example graphical output obtained by using IDL to plot data in the digital output files. Now, we will discuss the different forms of output and what is included in each.

### 7.1 The Default Printout

Every standard HE5 run generates an ASCII file of “printout” (the `Proot.txt` file found in the `output\HydroLight\printout` or `output\EcoLight\printout` directory) that is designed to be viewed with a text editor (or word processor). This file shows, in an easily read format, information such as

- The absorption, scattering, backscattering, and attenuation coefficients for each component of the IOP model
- The atmospheric parameters used in the sky radiance model
- Various irradiances (upward and downward scalar and plane irradiances)
- Nadir- and zenith-viewing radiances (HydroLight runs also show horizontal radiances at selected azimuthal directions relative to the sun’s position)
- Various apparent optical properties (mean cosines, reflectances, and diffuse attenuation functions)
- Quantities of interest in ocean-color remote sensing (incident and reflected sky radiance, water-leaving radiance; for nadir viewing only in EcoLight runs, for selected additional directions in HydroLight runs)
- PAR and CIE 1931 chromaticity coordinates for runs covering at least 400 to 700 nm
- Any warnings or error messages generated during the run

Quantities that are common to all wavelengths (e.g., atmospheric conditions or the IOP model selected) are grouped at the top of the printout. Quantities that depend on wavelength (e.g., IOP values or the bottom reflectance) are shown for each wavelength. Where appropriate, these quantities are tabulated at the user-defined depths where output was saved.

***It is strongly recommended that you always take a look at the printout after an HE5 run terminates.*** This is easily done by opening the file with NotePad or WordPad; you can also

use a word processor such as Microsoft Word® or WordPerfect® to view the file. Scan the input to make sure it was what you intended. Inspect the output to see if it looks physically plausible. If you see something peculiar in the output, try to figure out the cause—incorrect input, lack of intuition on your part about underwater light fields, or (perish the thought) a bug in HE5. For some purposes, it may be convenient to copy output from the default printout and paste it into graphics or spreadsheet software for further analysis.

The default printout gives a reasonable amount of information for most users. You can obtain more or less printout by selecting a different option in the Printout form of the UI (accessible from the FINAL form by selecting VIEW OUTPUT OPTIONS).

Some of the HydroLight radiance printout can be confusing until you are familiar with the directional conventions of radiative transfer theory and the HydroLight coordinate system shown in Figs. 3 and 4. Figure 13 therefore shows an annotated snippet of the default radiance printout from a HydroLight run, with selected quantities labeled.

**looking downward**
**looking away from the sun**
**looking towards the sun**

Selected Radiances (units of  $W/m^2 \text{ sr m}$ ) and Radiance-Irradiance Ratios at 435.0 nm

[Here (theta,phi) are directions of photon travel relative to nadir (solar photons travel

iz	zeta	z (m)	$I_u(z)$ (theta=180)	$I_d(z)$ (theta=0)	$I_h(z, \phi=0)$ (theta=90)	$I_h(z, \phi=90)$ (theta=90)	$I_h(z, \phi=180)$ (theta=90)	$I_i$ (
		in air	7.668E-03	5.878E-02	1.467E-01	1.117E-01	2.468E-01	7.8
1	0.00	0.00	9.396E-03	1.074E-01	1.849E-02	1.987E-02	3.031E-02	9.7
3	1.57	5.00	6.839E-03	1.574E-01	1.499E-02	1.831E-02	3.646E-02	9.8
5	3.13	10.00	4.864E-03	1.655E-01	1.180E-02	1.518E-02	3.094E-02	9.9
7	4.70	15.00	3.414E-03	1.476E-01	8.877E-03	1.174E-02	2.320E-02	9.9
9	6.27	20.00	2.378E-03	1.201E-01	6.546E-03	8.743E-03	1.633E-02	9.9

Fig. 13. Example HydroLight radiance printout with selected directions labeled. Note, for example, that to detect photons traveling in the  $\phi = 0$  direction you are looking away from the sun, which was in the  $\phi = 0$  azimuthal direction.

Figure 14 likewise shows the above-surface radiance printout from a run with the sun at a 30 deg zenith angle (and in azimuthal direction 0).

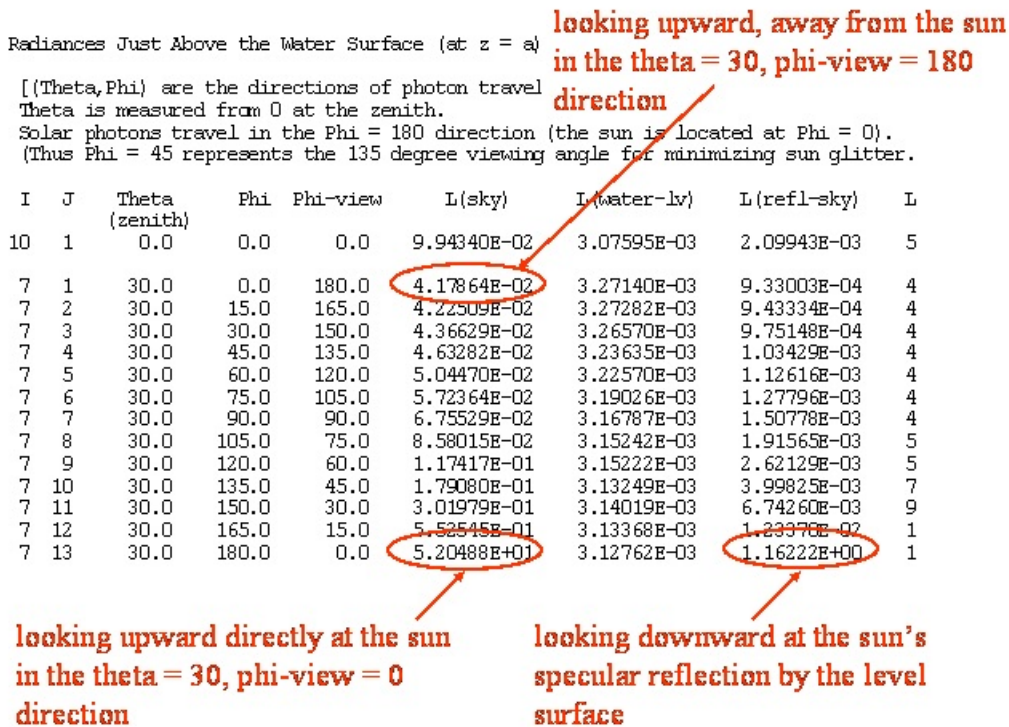

Fig. 14. Annotated snippet of HydroLight above-surface radiance printout. The sun was at ( $\theta_{\text{zenith}} = 30, \varphi = 0$ ).

**Note 1.** The depth indices  $iz$  shown in the default HydroLight printout (e.g., as seen in Fig. 13) may cause confusion. When you specify the depths where output is to be saved, *HydroLight* automatically adds a second depth just below each depth you specify. As explained in §5.7, these pairs of closely spaced depths (0.01 m apart by default) are used to compute diffuse attenuation functions ( $K$  functions) by finite-difference approximations to their definitions. However, most output is given only at the depths you requested. This can make it appear that output is being given at every other depth (indices  $iz = 1, 3, 5, \dots$  as seen in Fig. 13); the omitted indices ( $iz = 2, 4, 6, \dots$ ) correspond to the extra depths used to compute  $K$  functions and can be disregarded.

For *EcoLight*, however, this is not done. The user-requested output depths are used to compute the layer-averaged  $K$  functions, no matter how far apart the requested output depths are. This is one situation in which HydroLight and EcoLight output different quantities that, at first glance, may appear to be conceptually the same but numerically different. They are really different quantities—an estimate of the local  $K$  function vs. a layer-averaged  $K$  function.

Table 1 shows an example of the default printout for the irradiances and mean cosines. Note also that both the optical depth  $\zeta$  (“zeta” in the printout) and the geometric depth  $z$  (in meters) are shown in the printout. Values in the air, just above the sea surface, are also shown where appropriate. Table 2 shows the corresponding printout for various  $K$  functions. The closely spaced pairs of depths ( $z_k, z_{k+1}$ ) are shown in the printout as ( $z_{\text{upper}}, z_{\text{lower}}$ ). The small increment used in computing derivatives, which is 0.01 m by default, is set in the routine code\common\setdfits.f. Picking depths only 0.01 m apart exceeds the ability of oceanographic instruments to measure the corresponding changes in the light field, but such closely spaced values gives excellent depth resolution of  $K$  profiles in the numerical model.

Irradiances (units of W/m <sup>2</sup> nm), Mean Cosines (Mubars), and Irradiance Reflectance											
iz	zeta	z (m)	Eou	Eod	Eo	Eu	Ed	MUBARu	MUBARd	MUBAR	R = Eu/Ed
		in air	9.7675E-02	9.5298E-01	1.0507E+00	2.9105E-02	5.9866E-01	0.2980	0.6282	0.5421	4.8616E-02
1	0.00	0.00	2.3508E-02	6.7162E-01	6.9513E-01	9.4290E-03	5.7898E-01	0.4011	0.8621	0.8193	1.6286E-02
3	1.91	1.00	1.1631E-02	3.0982E-01	3.2145E-01	4.4336E-03	2.5288E-01	0.3812	0.8162	0.7729	1.7532E-02
5	3.82	2.00	5.1328E-03	1.3393E-01	1.3907E-01	1.9295E-03	1.0722E-01	0.3759	0.8006	0.7571	1.7995E-02
7	9.56	5.00	3.8325E-04	9.8290E-03	1.0212E-02	1.4244E-04	7.7349E-03	0.3716	0.7869	0.7435	1.8415E-02
9	19.11	10.00	4.6379E-06	1.1866E-04	1.2330E-04	1.7210E-06	9.3190E-05	0.3711	0.7853	0.7418	1.8467E-02

Table 1. Example of the default printout showing various irradiances, mean cosines, and the irradiance reflectance. The line labeled “in air” gives the values just above the air-water surface. Depth 0.00 is in the water, just below the surface. The user-requested output depths were  $z = 0, 1, 2, 5, 10$  m. These are the odd-indexed depths ( $iz = 1, 3, 5, 7, 9$ ); the even depths are used to compute  $K$  functions and are not shown in the default printout.

K-functions (units of 1/meter) (valid only when zupper and zlower are closely spaced)									
zupper	zlower	z	Kou(z)	Kod(z)	Ko(z)	Ku(z)	Kd(z)	Knet(z)	KLu(z)
0.000	0.010	0.005	0.53271	0.69107	0.68571	0.65229	0.79845	0.80088	0.77136
1.000	1.010	1.005	0.78821	0.81967	0.81853	0.80976	0.84798	0.84866	0.83940
2.000	2.010	2.005	0.83970	0.85297	0.85248	0.84853	0.86592	0.86623	0.86168
5.000	5.010	5.005	0.87829	0.88019	0.88012	0.87955	0.88207	0.88212	0.88124
10.000	10.010	10.005	0.88430	0.88422	0.88423	0.88424	0.88410	0.88409	0.88406

Table 2. The default printout showing the  $K$  functions corresponding to the irradiances of Table 1. The closely spaced pairs of depths ( $z_{\text{upper}}, z_{\text{lower}}$ ) used to compute the  $K$  functions are now shown explicitly.



## 7.2 Examining Output with EXCEL

Selected output is optionally written to two ASCII files that are formatted for conversion to Microsoft EXCEL spreadsheets. This conversion is performed using EXCEL macros that are provided with HE5. These files contain roughly the same information as the default printout and, likewise, can be tailored to the individual user's desires. The two files, **Mroot.txt** and **Sroot.txt** (where "root" is the root name set in the Run Identification form of the UI), are written by HE5 to the appropriate **excel** directory. They are structured as follows:

**Mroot.txt** will convert to an EXCEL workbook in which each sheet contains a single variable (such as the total absorption or the downwelling plane irradiance) as a function of depth and wavelength. This is the "multi-wavelength" format. This file is converted into a spreadsheet by running the macro **multiwl.xls**, which is in the **excel** directory.

**Sroot.txt** will convert to an EXCEL workbook in which each sheet contains several variables (such as the absorption, scattering, backscatter, and beam attenuation coefficients) as functions of depth, but grouped one wavelength at a time. This is the "single-wavelength" format. This file is converted into a spreadsheet by the **singlewl.xls** macro in the **excel** directory.

The way in which you run the macros depends slightly on the version of EXCEL you are using. (The following example is for EXCEL 2002.) Suppose, for example, that you have made a multi-wavelength HE5 run with the root name **UGEx4**, as in the example above, and told the UI on the **OUTPUT OPTIONS** form to create **Mroot.txt** files. The **excel** directory should then contain a file named **MUGEx4.txt**, as well as the macro files **multiwl.xls** and **singlewl.xls** (and any other **Mroot.txt** and **Sroot.txt** files from previous runs). To convert **MUGEx4.txt** to a workbook, follow these steps:

- Start EXCEL
- Select **FILE** → **OPEN**
- Go to the **excel** directory (under the **HE5\OUTPUT** directory), select **multiwl.xls**, click **OPEN**
- Click **ENABLE MACROS** if you get a warning message about the dangers of running macros
- Click **OK** if you get a message about having to use Visual Basic to open macros
- Either hit **CTRL-M** or select **TOOLS** → **MACRO** → **RUN** (select the macro named

Macro\_multiwave if it is not automatically highlighted) to start the macro.

- Click SELECT MROOT.TXT FILE TO BE CONVERTED from the macro's startup screen.
- Browse to the MUGEx4.txt file select it.
- The macro will run and convert the MUGEx4.txt file into a workbook.
- Click NO if you get a message asking if you want the information on the clipboard to be available later.
- The macro will ask if you want to save the workbook. If you answer YES, the default name for the workbook is MUGExr.xls (Mroot.xls in general).

Whether or not you save the workbook, the macro leaves you in the EXCEL workbook that has been created. At this point you are simply using EXCEL without regard to how the workbook was created or to the fact that the data came from HE5. You can, for example, now block out data and use the EXCEL plotting functions to create simple plots of the HE5 output. However, it is not the purpose of this users' guide to teach you EXCEL, so good luck and call the helpful folks at Microsoft if you have questions about EXCEL. Table 3 shows the first few rows of the first sheet of a workbook created in this manner.

---

Run Title: Users' Guide, Example Run												
abs coef	18		7									
a (1/m)												
wavelen	0		5		10		15		20		25	
360	6.03E-02	6.89E-02	8.73E-02	1.15E-01	9.70E-02	5.56E-02						
380	5.08E-02	5.91E-02	7.69E-02	1.03E-01	8.63E-02	4.62E-02						
400	4.44E-02	5.31E-02	7.16E-02	9.91E-02	8.14E-02	3.96E-02						
420	4.99E-02	6.07E-02	8.37E-02	1.18E-01	9.59E-02	4.39E-02						
440	5.35E-02	6.47E-02	8.87E-02	1.24E-01	1.01E-01	4.73E-02						
460	5.16E-02	6.15E-02	8.26E-02	1.14E-01	9.37E-02	4.62E-02						
480	4.82E-02	5.65E-02	7.42E-02	1.01E-01	8.36E-02	4.36E-02						
500	4.99E-02	5.67E-02	7.12E-02	9.27E-02	7.88E-02	4.62E-02						

---

Table 3. The first few rows and columns of an EXCEL work sheet created from an Mroot.txt file. There is one variable (here, the absorption coefficient  $a$ ) displayed as a function of wavelength (rows) and depth (columns).

Creating a workbook from the single-wavelength file proceeds in the manner just described, except that you run the macro named singlewl.xls and you give it the name of a file

on the single-wavelength format, e.g., **SUGEx4.txt** in the present example. Table 4 shows the first few rows of the first sheet of the workbook created from the example single-wavelength spreadsheet file.

---

Run Title: Users' Guide, Example Run					
Wavelength = 360.0 nm					
depth	a	b	c	omega0	bb
(m)	(1/m)	(1/m)	(1/m)		(1/m)
0	0.0603	0.3102	0.3705	0.8372	0.01146
5	0.0689	0.3794	0.4483	0.8463	0.01273
10	0.0873	0.5252	0.6125	0.8575	0.0154
15	0.1145	0.738	0.8525	0.8657	0.0193
20	0.097	0.6013	0.6983	0.8611	0.0168
25	0.0556	0.2717	0.3273	0.8302	0.01076

Wavelength = 380.0 nm					
depth	a	b	c	omega0	bb
(m)	(1/m)	(1/m)	(1/m)		(1/m)
0	0.0508	0.2919	0.3427	0.8519	0.00988
5	0.0591	0.3575	0.4166	0.8581	0.01108
10	0.0769	0.4956	0.5725	0.8656	0.01361
15	0.1034	0.6972	0.8006	0.8709	0.0173
20	0.0863	0.5677	0.6541	0.868	0.01493
25	0.0462	0.2554	0.3016	0.8469	0.00921

---

Table 4. The first few rows of the first worksheet created from an example **Sroot.txt** file. Note that there are several variables (columns) shown as functions of depth (rows), with a separate block of data for each wavelength.

The FORTRAN routines that write the **Mroot.txt** and **Sroot.txt** files are found on file `code\common\excel.f`. Subroutine **WRTXCLS** writes the **Sroot.txt** files and subroutine **WRTXCLM** writes the **Mroot.txt** files. Those routines contain extensive documentation explaining how to modify the routines to obtain more or less output for conversion to EXCEL spreadsheets.

### 7.3 Plotting Output with IDL

Many HE5 users prefer the IDL software package for plotting output from HE5 runs (IDL is Interactive Data Language, a product of ITT Visual Solutions, Inc.). The HE5\examples\IDL directory distributed with the HE5 code contains the routines used to plot some of the figures in this User's Guide. If you are familiar with IDL (and of course have the IDL software on your computer), running these routines will be straightforward. If you do not want to use IDL, you do not need the files on the HE5\examples\IDL directory. These IDL routines are NOT a part of HE5, but are provided "as is" for the benefit of IDL users.

The IDL routine `read_H_Dfile.pro` reads the HE5 `Droot.txt` files. Likewise, `read_H_Lfile.pro` reads the `Lroot.txt` files, and `read_E_Dfile.pro` reads `EcoLight Droot.txt` files. These large files contain *all* of the output from an HE5 run and are formatted for ease of reading into IDL. All of the information contained in a `Droot.txt` or `Lroot.txt` file is made available to the IDL main program via common blocks. A main IDL program can then generate the desired plots using the appropriate HE5 output. For example, to regenerate Fig. 8:

- Start IDL by double clicking on routine HE5\examples\IDL\HE5UG\_Fig8.pro. Alternatively, start IDL and then and change into the HE5\examples\IDL directory by typing:  

```
cd, 'c:\HE5\examples\idl'
```

at the IDL command prompt.
- Compile the code (this must be done each time you launch IDL) by typing  

```
.run HE5UG_Fig8
```
- Run the code by typing `plot_Rrs` (the name of the program in file HE5UG\_Fig8.pro). The program will prompt you to browse for the `Droot.txt` file(s) you wish to process. (Other IDL routines may prompt you for additional information, such as the depths or wavelengths to be plotted.)

Note: These commands work only for IDL version 6.4 and earlier. IDL version 7.0 has a totally different interface and does things differently; you're on your own figuring out how to use IDL 7.0. Let me know if you can figure out how to make IDL 7.0 work like 6.4.

**Note 1.** IDL will want to know the *\*filename\** that contains the code it needs to compile, not the name of the program contained therein. For instance, the IDL routine `plot_Rrs` is

contained in the file HE5UG\_Fig8.pro, hence you compile file HE5UG\_Fig8.pro (not plot\_Rrs) and then run the main program plot\_Rrs found therein.

**Note 2.** There is a point of perpetual confusion when using IDL to plot HE5 output. In HE5, an  $N$ -dimensional array  $A(i)$  is usually (but not always) indexed from 1 to  $N$ , i.e.  $A(1)$  to  $A(N)$ . In IDL, array indices always begin with 0, so that the same array is indexed as  $A(0)$  to  $A(N-1)$ . This can be especially confusing when you are trying to extract blocks from multidimensional arrays in order to generate, for example, plots of the radiance distribution as seen in Fig. 11. To make matters worse, some HE5 arrays are indexed beginning with 0. For example, the arrays that store irradiances use depth index 0 to store the irradiance in the air, just above the surface. In this case, the HE5 and IDL array indices are the same. Most IDL users have learned to live with these sorts of indexing mismatches, but if you have not, be forewarned and do some extra debugging of your IDL routines to make sure you are plotting exactly the HE5 output you want and not something that is off by one element in the array.

## 8. ADVICE ON RUNNING HE5

This section gives a few words of advice that may help you run HE5 more efficiently.

### 8.1 Depth Considerations

The relevant measure of depth in radiative transfer theory is the dimensionless *optical depth*  $\zeta$ , not the geometric depth  $z$ . This can lead to confusion in understanding HE5 run times. For example, in homogeneous clear water at blue wavelengths, where the beam attenuation is  $c \approx 0.02 \text{ m}^{-1}$ , 50 m is only about  $\zeta = cz = (0.02 \text{ m}^{-1})(50 \text{ m}) \approx 1$  optical depth. In highly absorbing or scattering water with  $c = 1 \text{ m}^{-1}$ , 50 m corresponds to 50 optical depths. In this case, HE5 will require about 50 times as long to obtain a solution to the same geometric depth as it does in the clear water. This dependence of run time on optical depth causes an unavoidable run-time penalty when running HE5 at red or near-IR wavelengths (especially beyond 750 nm; the absorption coefficient of pure water is about  $45 \text{ m}^{-1}$  at 970 nm). Runs to even a few meters of geometric depth require the solution of the RTE to many optical depths at long wavelengths, even in pure water. Thus, much of the total run time can be expended in solving the RTE at the longer wavelengths. Therefore, *do not run HE5 to longer wavelengths than are really necessary to solve your problem.*

There is a trick that can enormously speed up the HE5 run time in one special situation. *If (and only if) you are modeling a homogeneous, infinitely deep water body, and neglecting any fluorescence or internal sources, and the only output you need is the water-leaving radiance, then you can apply the bottom boundary condition at a nominal depth (say, 0.1 m).* (That is, request output only at depths 0.0 and 0.1 m and select the “infinitely deep water” bottom boundary condition.) The water-leaving radiances will be *exactly* the same as if you had solved the RTE to a greater depth, but the run time will be minimal. If you use this trick, you will of course not have any output for the light field below 0.1 m within the water, but that is irrelevant for remote-sensing studies. Note that the water-leaving radiances will not be the same in these “deep” and “shallow” simulations if the water IOPs vary with depth or if the water is actually shallow and the bottom boundary has significant effects on the emerging light field. Also, the inelastic-scatter effects cannot be computed unless you run the simulation to sufficient depth.

HE5 automatically solves the RTE with extremely fine depth resolution in the IOP's. The numerical algorithms can take very small depth steps ( $\sim 10^{-6}$  optical depths or less) when solving the Riccati equations (*Light and Water*, Eqns. 8.74-8.85) that lie at the core of the HE5 calculations. These calculations typically require about 90 percent of the HydroLight run time. As already noted, the primary factor influencing the run time is the optical depth to which a calculation is performed. The run time is much less influenced by the depth dependence of the IOPs. Thus, for example, solving the RTE for the binned absorption profile seen in Fig. 1 (the left-hand curve) does not require much more time than solving the RTE for a homogeneous water body with the same average absorption profile. (This statement does have its limits, though, as discussed in Section 1.1.) This near independence of run time on IOP depth structure is one of the most powerful features of HE5, compared to other solution techniques.

HE5 saves the computed radiances only at the *user-selected output depths*  $z_k$ ,  $k = 1, 2, \dots, K$ , which are specified along with the other input to a standard run. The output depths can be arbitrarily spaced in order to get detailed output in the regions of greatest interest, such as near the sea surface or near strong gradients in the IOP's, and less output in regions where there is little "fine structure." *It is very important to note that the solution of the RTE is independent of where output is to be saved for later analysis.* For example, you might request output at one-meter depth intervals, i.e.,  $z_1 = 0$ ,  $z_2 = 1.0$  m,  $z_3 = 2.0$  m, ...,  $z_6 = 5.0$  m, ..., and so on. On the other hand, you might request output at  $z_1 = 0$ ,  $z_2 = 5.0$  m, ..., and so on. The output at 5.0 will be exactly the same in both cases; the only difference is that we will have more output between 0 and 5.0 m in the first case. In particular, HE5 does *not* solve the RTE with "one-meter depth resolution" in the first case and with "five-meter resolution" in the second case. The number of depths where output is saved does not significantly affect the run time (the only difference is the small amount of time required to write the output files). The size of the output files is, of course, directly proportional to the number of depths where output is saved.

The default array dimensioning supports output at 50 user-specified depths (strictly speaking, at 50 pairs of closely spaced depths, as described in Section 7.1). This parameter can be changed in the UI (via the CHANGE LIMITS form) if output at more depths is needed.

Most oceanographers want output at *geometric* depths  $z_k$ , measured in meters, for ease of comparison with observational data. However, in some cases the output depths also can be specified as dimensionless *optical* depths  $\zeta_k$ . This option is available only if the model is being run at just one wavelength, because the wavelength dependence of the IOP's makes a given optical depth correspond to different geometric depths (different physical locations in the water column) at different wavelengths. Computations in terms of optical depths are convenient for general monochromatic radiative transfer studies, as opposed to specific oceanographic

studies. Note that if the model is being run with optical depths, then the IOP routine must be written to accept optical depth as input. Of the example routines distributed with HE5, only `abconst` accepts both optical and geometric depths.

## 8.2 Wavelength Considerations

The various data sets built in to HE5 give it the ability to run anywhere in the wavelength domain 300-1000 nm, which is of interest in optical oceanography.

There are two basic options for specifying the needed wavelength information. The first is to run HE5 at a single wavelength. HE5 then solves the *monochromatic* RTE with the IOP's, sky radiances, and bottom reflectance being taken equal to their values at the specified wavelength. Some routines, for example the “semi-analytical” RADTRAN sky irradiance model, have built-in data that are accurate to 1 nm resolution. Other routines, for example the absorption and scattering coefficients for pure water, have data built in at 5 nm or 10 nm resolution. Such routines generally use linear (optionally, cubic spline) interpolation to obtain IOP's at the requested wavelength. A run at a single wavelength can include an internal source term at that wavelength. Such a source term can represent a bioluminescing layer, for example. The output depths can be either geometric or optical depths. Monochromatic runs are most useful for general radiative transfer studies.

The second option is to run HE5 over one or more contiguous wavelength bands with bandwidths  $\Delta\lambda_j, j = 1, 2, \dots, J$ . When this option is chosen, the model automatically averages the input sky radiance over each wavelength band. This averaging smooths out the large nanometer-to-nanometer fluctuations in the sky radiance magnitude owing to Fraunhofer lines in the solar spectrum. However, *the absorption and scattering coefficients are taken to be the values at the band centers*. In principle,  $a(z, \lambda)$  and  $b(z, \lambda)$  also should be averaged over each band. However, this averaging would have to be performed every time the IOP subroutine is called with a new depth during the solution of the RTE; such averaging would be an enormous computational expense. If the band widths are of size  $\Delta\lambda \leq 20$  nm, then the replacement of band-averaged IOP values by band-center values will be acceptably accurate for most purposes, because oceanic IOP's (unlike the solar irradiance and atmospheric IOPs) do not fluctuate wildly on a nanometer scale.

Most present-day oceanographic and remote-sensing sensors have bandwidths of 5-20 nm. The bandwidths of an HE5 run can be matched to these sensor bandwidths if desired. There is no requirement that the bandwidths  $\Delta\lambda_j$  be equal for different  $j$  values (recall Fig. 12). If the



user wishes to simulate a wider-bandwidth instrument, then HE5 should be run with a number of smaller bandwidths. The final output for the smaller bandwidths then can be averaged to get band-averaged output for the wide band. This approach properly accounts for the wavelength variation of the IOP's within the large band. Note that it is seldom necessary to make high-wavelength resolution runs. Figure 15 shows  $R_{rs}$  for a given set of IOPs and other input, but with output requested at resolutions of 1, 5, 10, 20, and 50 nm. Even with a resolution of 50 nm, the calculated  $R_{rs}$  at the middle of the band is nearly indistinguishable from the high resolution result. The reason is that HE5 uses the IOP values at the middle of the bandwidth in its calculations.

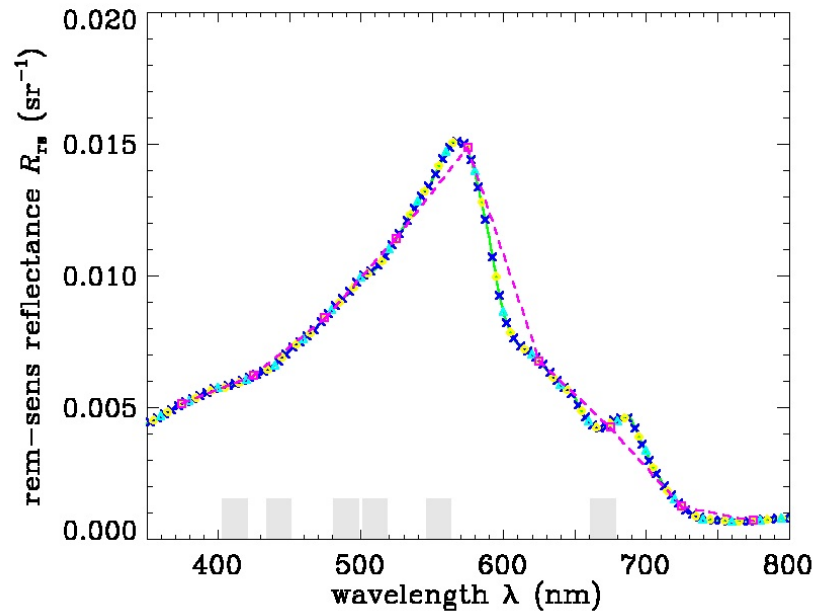

Figure 15. Remote sensing reflectance in a simulated Case 2 water body ( $5 \text{ mg/m}^3 \text{ Chl}$ , moderate CDOM, and  $2 \text{ g/m}^3 \text{ mineral}$ ) with output resolutions of 1 nm (solid green line), 5 nm (dark blue x), 10 nm (yellow circles), 20 nm (light blue triangles), and 50 nm (magenta squares connected by dashed line). The gray bars show the SeaWiFS bands.

For calculations of PAR and fluorescence, HE5 assumes the values across the bandwidth are constant and equal to the “mid band” value. You will need to select the resolution based on what you are trying to calculate. For instance, in Fig. 15, 50 nm resolution might be acceptable if all you want is a few specific  $R_{rs}$  values, however it is not sufficient to resolve the

true shape of the  $R_{rs}$  curve as a function of wavelength. In general, most HE5 runs should have bandwidths no larger than 20 nm.

Another consideration in the choice of wavelength bands arises in connection with inelastic scattering effects. Suppose, for example, that we wish to simulate the light field in the 450-500 nm region. If we are uninterested in inelastic-scattering effects from shorter wavelengths, then we could run HE5 with five bands chosen as 450-460 nm, 460-470 nm, ..., 490-500 nm, for example. However, if we wish to include the contributions of fluorescence or Raman scattering to the light field in the 450-500 nm region, then HE5 must be run for all wavelengths less than 450 nm for which there might be an inelastic-scattering contribution to the region of interest. Thus to include Raman scatter, the model should be run starting with a band from 390-400 nm, because wavelengths near 400 nm will Raman scatter into wavelengths near 450 nm. If CDOM fluorescence is to be included, then HE5 should be run starting at 350 nm, because CDOM fluorescence can be excited by ultraviolet wavelengths and because CDOM fluoresces throughout the visible.

### 8.3 Inelastic Scattering and Bioluminescence

HE5 has the option of running with or without inelastic scattering and internal sources being included in the RTE. The inelastic scattering processes included are chlorophyll fluorescence, CDOM fluorescence, and Raman scattering. The internal source usually is tailored to represent a horizontal layer of bioluminescence. If these effects are all omitted from the run, then HE5 carries out a sequence of independent solutions of the monochromatic, source-free RTE. The solutions for different wavelength bands are then completely independent. However, if one or more of these effects are included, then the appropriate source terms are automatically added to the RTE, as described in *Light and Water*, Sections 5.14-5.16 and 8.7. In the case of inelastic scattering, the solutions in different wavelength bands are coupled by the inelastic scattering from shorter to longer wavelengths. The inelastic-scattering and internal-source computations in some cases call upon user-supplied routines.

HE5 models CDOM fluorescence using the spectral fluorescence quantum efficiency function of *Light and Water* Eq. (5.101), as shown in *Light and Water* Fig. 5.11. This particular function is built in to routine `wrfcdom` on file `wrfdisc.f`. The user can replace this default function with another, if desired.

Because Raman scattering depends only on the water itself, no user-supplied information is required. Various parameter values, such as the Raman cross section and chlorophyll fluorescence quantum efficiency, can be set on the `CHANGE DEFAULTS` form of the UI.

Some additional computational expense results from the addition of the source terms seen in Eqs. (8.74)-(8.85) of *Light and Water*. However, the main increase in computation time when inelastic scattering is included arises from the need to run the model over wavelengths shorter than the wavelengths of interest, as was illustrated in the previous subsection. In the example discussed there, where the interest was only on 450-500 nm, including CDOM fluorescence effects on the 450-500 nm band requires about three times the computational expense, because the model then must be run from 350-500 nm.

HE5 includes chlorophyll and CDOM fluorescence and bioluminescence as formulated in Sections 5.15 and 5.16 of *Light and Water*. However, Raman scatter is included using an azimuthally averaged effective source term that is equivalent to the formulation seen in Appendix A of Mobley, et al. (1993). This simplification allows the Raman effective source term to be computed from the scalar irradiance (as is the case for fluorescence), rather than from the full radiance distribution. The azimuthally averaged formalism yields the correct Raman contribution to irradiances, which are computed from the azimuthally averaged radiance. However, the Raman contribution to the radiance is correct only as an azimuthally averaged value.

## 8.4 Setting Defaults

Many of the calculations performed within HE5 assume default values for various parameters in order to minimize the input required from users for each run. These defaults can be simple numbers, such as the chlorophyll-fluorescence quantum efficiency; entire data sets, such as are used by the atmospheric models contained within the sky radiance models; or functions, such as the excitation-emission spectrum for CDOM fluorescence. In most cases, the default values are set to typical or average values for the marine environment; these default values may or may not be adequate for your particular simulation. Defaults are also used to set the amount and type of output obtained from a run.

There are a number of subroutines in the `code` directory where defaults are set. Most parameters of interest can be changed within the UI (for example, the maximum number of depths, type/amount of output, sky parameters, etc.).

## 8.5 Making Special Runs

A special HE5 run is required in three circumstances: (1) a new phase function is to be prepared and added to the collection of available phase functions, (2) a new surface wind speed

is needed, or (3) a new quad or band layout is needed. Because of the infrequent need (never, for most users) for making special runs, control of these runs is not incorporated into the UI. Special runs can be made only by creating the needed input file with a text editor and then submitting the run from a command window; this is easy to do. Special runs are described in the Technical Documentation.

## REFERENCES

- Acharya, P. K., et al., 1998. MODTRAN User's Manual, Versions 3.7 and 4.0 - Draft, Air Force Research Lab, Hanscom AFB, Ma 01731-3010, 79 pages.
- Dongarra, J. J. and E. Grosse, 1987. Distribution of mathematical software via electronic mail, *Commun. ACM*, 30(5), 403-407.
- Gregg, W. W. and K. L. Carder, 1990. A simple spectral solar irradiance model for cloudless maritime atmospheres, *Limnol. Oceanogr.*, 35(8), 1657-1675.
- Harrison, A. W. and C. A. Coombes, 1988. An opaque cloud cover model of sky short wavelength radiance, *Solar Energy*, 41(4), 387-392.
- Kirk, J. T. O., 1994. *Light and Photosynthesis in Aquatic Ecosystems*, Cambridge University Press, Cambridge, 509 pages.
- L&W = *Light and Water*; see Mobley (1994)
- MODTRAN, see Acharya, et al. (1998).
- Mobley, C. D., 1994. *Light and Water: Radiative Transfer in Natural Waters*, Academic Press, San Diego, 592 pp.
- Mobley, C. D., 1995. *The Optical Properties of Water*, Chapter 43 in *Handbook of Optics, Second Edition, Volume I*, M. Bass, Editor in Chief, McGraw-Hill and Optical Society of America, New York, 56 pages.
- Mobley, C. D., B. Gentili, H. R. Gordon, Z. Jin, G. W. Kattawar, A. Morel, P. Reinersman, K. Stamnes, and R. H. Stavn, 1993. Comparison of numerical models for computing underwater light fields, *Appl. Opt.*, 32, 7484-7504.
- Spinrad, R. W., K. L. Carder, and M. J. Perry, 1994. *Ocean Optics*, Oxford University Press, New York, 283 pages.

## **APPENDIX A. LICENSE AGREEMENT FOR USE OF HYDROLIGHT-ECOLIGHT 5**

This license agreement is also contained in the source code and in the UI.

### HydroLight-Ecolight version 5 SINGLE-USER LICENSE AGREEMENT

HYDROLIGHT-ECOLIGHT version 5 is Copyright © 2008 by Curtis D. Mobley. HYDROLIGHT and ECOLIGHT are owned by Curtis D. Mobley and are protected by United States copyright laws and international treaties.

These computer programs, named HYDROLIGHT and ECOLIGHT and consisting of various main programs and subroutines, hereafter referred to collectively as "HYDROLIGHT-ECOLIGHT version 5" or as "HE5", are being licensed to the User on a non-exclusive, non-transferable license for use in scientific research.

The following requirements, which with the preceding paragraphs constitute an agreement for use of HYDROLIGHT- by the User (hereafter called "the Agreement") are to be upheld:

- (1) HYDROLIGHT-ECOLIGHT version 5 may be installed on the same two computers on which the Lahey Fortran 95 Express compiler that comes with HE5 has been installed. You may not network HE5 or otherwise use it on more than two computers or computer terminals at a time.
- (2) This entire notice must be retained within each main program of the source code.
- (3) The following notice must be legibly displayed on the monitor or other output when HE5 is performed:

HYDROLIGHT-ECOLIGHT version 5 is Copyright (c) 2008 by Curtis D. Mobley

HYDROLIGHT-ECOLIGHT IS EXPERIMENTAL AND IS LICENSED "AS IS"  
WITHOUT REPRESENTATION OF WARRANTY OF ANY KIND, EITHER

EXPRESS OR IMPLIED. THE ENTIRE RISK AS TO THE QUALITY AND PERFORMANCE OF HYDROLIGHT-ECOLIGHT IS WITH THE USER.

(4) Title to HE5 and all portions thereof shall at all times remain with Curtis Mobley. HE5 is licensed, not sold, to the user.

(5) Any alterations, variations, modifications, additions, or improvements to HE5 or merger into other program material to form a derivative work made by the User shall be made or done at the User's own risk and expense. Any modification or combination shall not dilute or limit Curtis Mobley's rights with respect to those portions of any derivative work (in original, modified, or combined form) incorporating any portion of HE5. Any portion of HE5 included in a derivative work shall remain subject to the terms of this Agreement.

(6) The User acknowledges that HE5 is valuable to Curtis Mobley and shall be held in confidence as proprietary to Curtis Mobley, and that HE5 is licensed solely for the User's use subject to the terms of this Agreement. The User agrees not to disclose or provide HE5, in any form, to any person, party, or entity without the prior written consent of Curtis Mobley, except that the User may provide HE5 to his employees, consultants, or students as reasonably necessary to exercise his rights under this Agreement.

(7) The User agrees that HE5 (including any documentation and/or instructions for its use) is made available without warranty of any kind expressed or implied or statutory, including but not limited to the implied warranties of merchantability, fitness for a particular purpose, or conformity with whatever documentation, user manuals or other literature as may be issued by Curtis Mobley or Sequoia Scientific, Inc. from time to time. The user is warned that HE5 is not fault tolerant, and must not be relied upon in situations where financial loss, disruption of business or research, or other pecuniary loss could occur from an inability to use HE5 or from the incorrectness of its output.

(8) In no event shall Curtis Mobley and/or Sequoia Scientific, Inc. be liable for costs of procurement of substitute products or consequential damages, however caused and on any theory of liability, arising out of or related to this Agreement, even if Curtis Mobley and/or Sequoia Scientific, Inc. have been advised of the possibility of such damages.

(9) The User agrees to defend, indemnify and hold Curtis Mobley and Sequoia Scientific, Inc. harmless from any loss, cost, expense, claim, liability, demand or cause of action arising in any way from the User's use of HE5, or any products based on HE5.

(10) In the event that the User desires to develop a product, system, or service based in whole or in part on HE5 or which incorporates any portion of HE5, the User will not manufacture, sell or otherwise commercially exploit such a resultant product, system, or service before obtaining a written agreement from Curtis Mobley granting such rights, which may be granted by Curtis Mobley at his sole discretion.

(11) If you licensed HE5 in the United States, this agreement is governed by the laws of the State of Washington.

(12) This license will terminate automatically if the User fails to comply with the conditions and limitations described herein. On termination, the User must uninstall HE5 and destroy all copies of the software and documentation.

(13) It is requested, but not required, that the use of HE5 be suitably referenced or acknowledged in publications, papers, reports, presentations, or other communications for which HE5 was used as a part of the study being reported upon. It is requested, but not required, that the user of HE5 provides to Curtis Mobley a copy of all publications, reports, or other documents in which the use of HE5 is acknowledged.

THE USE OF HYDROLIGHT-ECOLIGHT 5 IMPLIES THE USER'S ACCEPTANCE OF THE ABOVE AGREEMENT.