



CYCLOPS

SUBMERSIBLE SENSORS

User's Manual



June 29, 2012
P/N 998-2100
Revision 2.1

TURNER DESIGNS
845 W. Maude Avenue
Sunnyvale, CA 94085
Phone: (408) 749-0994
FAX: (408) 749-0998

Table of Contents

1. Introduction	
1.1 Description	4
2. Inspection and Setup	
2.1 Instrument Checklist	5
2.2 Housing Configurations	5
2.3 Optional Accessories	6
2.4 Functional Test	7
3. Measurements with the Cyclops	
3.1 Introduction	8
3.2 Setting the Gain	8
3.2.1 Gain Determination Procedure	8
3.2.2 Static Gain Control	9
3.2.3 Auto Gaining	9
3.3 Direct Concentration Calibration	9
4. Turbidity Cyclops	
4.1 Introduction	11
4.2 Calibration	11
5 Maintenance and Warranty	
5.1 Maintenance	12
5.1.1 Rinsing	12
5.1.2 Care for the bulkhead connector	12
5.1.3 Cleaning the Optics	12
5.2 Warranty Terms	12
5.3 Warranty Service	13
5.4 Out of Warranty Service	13
Appendices	
A Specifications	15
B Recommended Measurement Practices	16
C Wiring Guide	17
D Pigtail Cable and Connector Information	18
E Controlling the Gain	19
F Linear Range, Quenching and Temperature Considerations	20
G Using the Cyclops Submersible Sensor with the DataBank	21

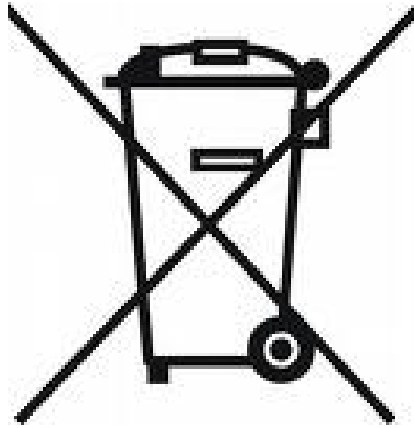

WASTE ELECTRICAL AND ELECTRONIC EQUIPMENT (WEEE) DIRECTIVE

Turner Designs is in the business of designing and selling products that benefit the well-being of our environment. Accordingly, we are concerned with preserving the surroundings wherever our instruments are used and happy to work with customers by complying with the WEEE Directive to reduce the environmental impact resulting from the use of our products.

WEEE Return Process:

To arrange the return of an end-of-life product, proceed as follows:

If you purchased your instrument through a Turner Designs Distributor please contact your local representative. They will instruct you where to return the end-of-life product.

If you purchased your instrument directly from Turner Designs please contact Turner Designs Customer Service

By Phone: 1-408-212-4041 or Toll Free: (877) 316.8049

By Email: Customer Service at support@turnerdesigns.com

Turner Designs will provide a WEEE RMA Number, a Shipping Account Number, and a Ship to Address. Package and ship the product back to Turner Designs.

The product will be dealt with per Turner Designs' end-of-life recycling program in an environmentally friendly way.

Cyclops Submersible Sensor

1. Introduction

1.1 Description

The Turner Designs Cyclops Submersible Sensor is an accurate single-channel detector that can be used for many different applications. It is designed for integration into multi-parameter systems from which it receives power and delivers a voltage output proportional to the concentration of the fluorophore, particle, or compound of interest.

The Cyclops voltage output can be correlated to concentration values by calibrating with a standard of known concentration.

Cyclops Submersible Sensor

2. Inspection and Setup

2.1 Instrument Checklist

The Cyclops Submersible Sensor shipment package consists of:

- Cyclops Submersible Sensor:

Configured and factory scaled for the specified analysis (see Identification Letter stamped on the connector for specified analysis):

- “C” = Chlorophyll
- “R” = Rhodamine
- “F” = Fluorescein
- “P” = Phycocyanin
- “E” = Phycoerythrin
- “U” = CDOM / FDOM
- “O” = Crude Oil
- “B” = Optical Brighteners
- “T” = Turbidity
- “G” = Refined Fuels
- “A” = PTSA

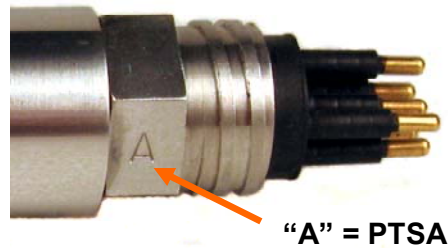

- USB Flash Drive (per order) which includes:

- User’s Manual
- Quick Start Guide
- *in vivo* Calibration Procedure
- Cable Guide
- Accessory instructions
- CE Certificate
- Optical Specification Guide

- Calibration Certificate

2.2 Housing Configurations:

- Stainless Steel Cyclops-7 (P/N: 2100-000-“Identification Letter”)
- Plastic or Titanium housings (recommended for highly corrosive environments or long term deployments).
 - Titanium Cyclops-7 (P/N: 2100-000-“Identification Letter” T)
 - Plastic Cyclops-7 (P/N: 2108-000-“Identification Letter”)
 - Plastic Cyclops-7 with Titanium connector (P/N: 2108-000-“Identification Letter”T)
- 6000 meter Cyclops-6K (P/N: 2160-000-“Identification Letter”)

Cyclops Submersible Sensor

2.3 Optional Accessories include:

- Cyclops Pigtail Cables with Locking Sleeve (*see Appendix D for more information*)
 - 2 foot Pigtail Cable with Locking Sleeve (P/N 2100-750)
 - 5 meter Pigtail Cable with Locking Sleeve (P/N 2100-755)
 - 10 meter Pigtail Cable with Locking Sleeve (P/N 2100-751)
 - 25 meter Pigtail Cable with Locking Sleeve (P/N 2100-752)
 - 50 meter Pigtail Cable with Locking Sleeve (P/N 2100-753)
- DataBank Handheld Data Logger (*see Appendix G*) (P/N 2900-000)
- Flow Cap (*see Accessory Instructions on USB Flash Drive*)
 - Cyclops-7 Stainless Steel and Titanium (P/N 2100-600)
 - Cyclops-7 Plastic (P/N 2100-608)
 - Cyclops-6K (P/N 2160-600)
- Shade Cap (*see Accessory Instructions on USB Flash Drive*)
 - Cyclops-7 Stainless Steel and Titanium (P/N 2100-701)
 - Cyclops-7 Plastic (P/N 2100-708)
 - Cyclops-6K (P/N 2160-700)
- Solid Secondary Standard (SSS) for *in vivo* Chlorophyll, Phycocyanin, Phycoerythrin, Rhodamine, Fluorescein (*see Accessory Instructions on USB Flash Drive*)
 - Cyclops-7 Stainless Steel and Titanium (P/N 2100-900)
 - Cyclops-7 Plastic (P/N 2100-908)
 - Cyclops-6K (P/N 2160-900)
- Solid Secondary Standard (SSS) for UV Sensors (CDOM / FDOM, Optical Brighteners, Refined Fuels and Crude Oil) (*see Accessory Instructions on USB Flash Drive*)
 - Cyclops-7 Stainless Steel and Titanium (P/N 2100-904)
 - Cyclops-7 Plastic (P/N 2100-905)
 - Cyclops-6K (P/N 2160-901)



Shade Cap

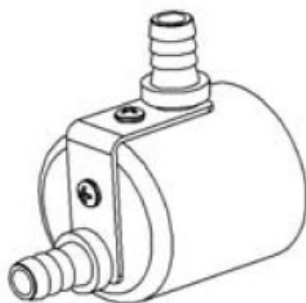

Flow Cap



Solid Secondary Standard

Cyclops Submersible Sensor

2.4 Functional Test

To perform a functional check on the Cyclops, connect the interface colored wires to the power supply and multi-meter as shown in Figure 1 below.

Additional Equipment required for functional tests:

DC Power Supply, 3 - 15 VDC, >100 mA

Multi-meter to read 0 – 5 VDC



Note: Supply voltages greater than 15 VDC will result in damage to the sensor.

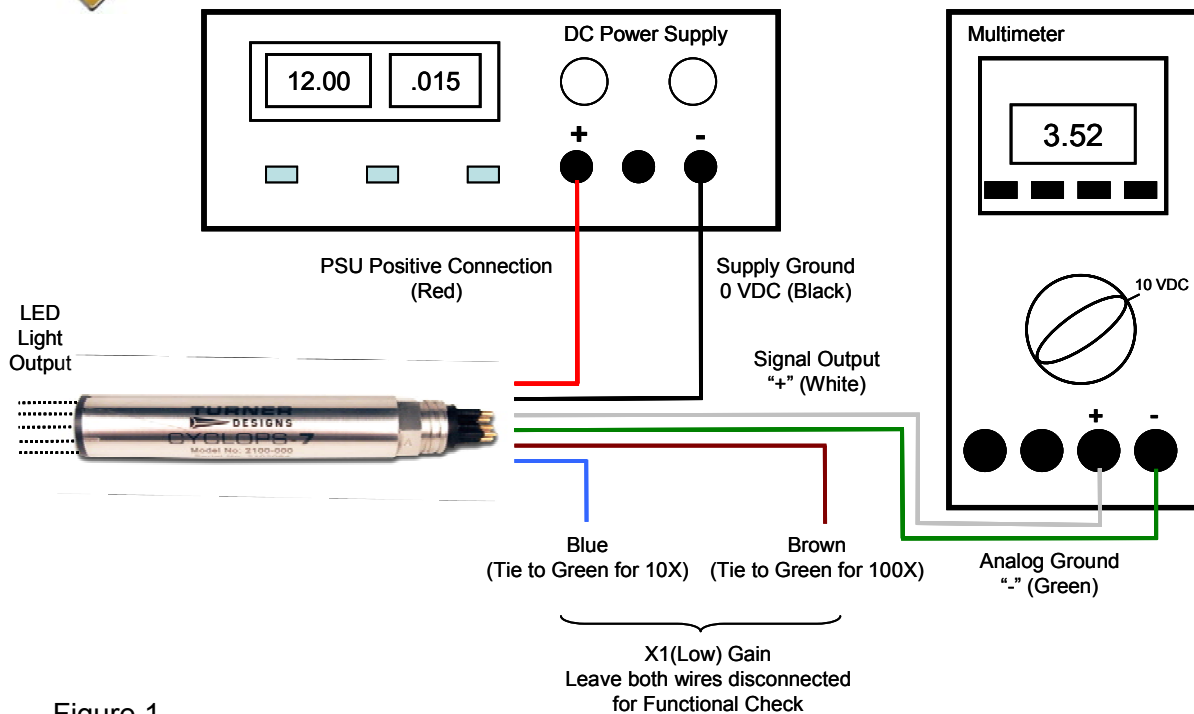

Figure 1.

With the Cyclops connected as shown in Figure 1 answer questions 1-3 by making the following functional tests:

1. Is the LED on?
Hold a piece of white paper about ½ an inch in-front of the optical head to ensure the LED is on. **Note: Cannot perform this test for Turbidity sensors because they use IR which is not visible.**
2. Is there voltage output?
The multi-meter should be reading some voltage >0 VDC
3. Does the voltage output change?
Move the light source closer to your hand or a surface and check if the voltage output increases

Cyclops Submersible Sensor

3. Measurements with the Cyclops

3.1 Introduction

The following information will describe how to:

- Determine and set the appropriate gain
- Calibrate the Cyclops using standards with known concentrations
- Make measurements with the Cyclops
- Use the Solid Secondary Standard

Note: To make accurate and repeatable measurements it is important to keep the sensor clean; see section 5.1 for information on cleaning your sensor.

3.2 Setting the Gain

Gain setting refers to the sensitivity configuration of the sensor. There are three gain settings; X1, X10 and X100. As the gain increases, the sensitivity increases and the concentration range decreases.

3.2.1 Gain Determination Procedure

- 1) For *in vivo* applications, take a natural sample of water from a sampling station where you plan to deploy the Cyclops. Applying good measurement practices, store it properly and quickly transport it to a laboratory where you have the Cyclops connected to a multi meter and DC power source (see *Figure 1*).
- 2) Pour the water sample into a clean glass beaker and submerge the optical end of the Cyclops (see *Appendix B for "Recommended Measurement Practices for using your Cyclops in the Lab" for how best to accomplish these steps*).
- 3) Activate the X10 gain setting (see *Wiring Guide Appendix C*) if you believe the sample to represent a typical condition. You would like to obtain a signal from the sample that is significantly higher than a blank sample (de-ionized water or filtered seawater), but not a signal that is close to the maximum of 5 Volts.
- 4) If the sample signal is high, (>3.0 V for example) you may choose to use the X1 gain instead of the X10 gain setting so that you avoid going over scale once you deploy the Cyclops.
- 5) If the sample signal is very low (<0.3V) you may choose to use the X100 gain setting to achieve higher sensitivity but a smaller measurable range

This process is easier for dye tracing applications. Simply create the dye dilution of interest and record what signal level it provides on the three gain settings.

Cyclops Submersible Sensor

3.2.2 Static Gain Control

If integrating into a multi parameter system or data logger that is set up for “Static Gain Control”, which refers to the use of only one gain setting at a time, then you must determine which gain to use prior to deployment (see section 3.2.1) and have an integration cable made to activate that specific gain (see *Appendix C*). For most applications the X10 gain will provide the best sensitivity, range, and resolution.

Customers wanting to dynamically change the gain ranges to achieve the optimum operating range should refer to “Method 2 – Dynamic Gain Control” in *Appendix E* on how to interface with a Data Collection System with programmable outputs.

3.2.3 Auto Gaining

Certain data loggers or multi parameter systems will have an auto gaining feature which will automatically adjust the sensitivity according to the voltage output from the Cyclops sensor. This feature maximizes the performance of Cyclops sensors allowing users to detect a broad range of concentrations, obtain the best resolution, and read minimum detection limits without having to rewire or manually change the sensor’s sensitivity. Turner Designs manufactures the DataBank Handheld Data Logger (see *Appendix G*) which has the auto gain feature and other functions that maximize the performance of Cyclops sensors.

3.3 Direct Concentration Calibration

Calibrating the Cyclops is a simple process requiring the use of calibration standards. The Cyclops can be calibrated using a single calibration standard which correlates the standard’s concentration to the voltage measured for that specific standard:

- 1) Connect the Cyclops to a power source and set the Cyclops to a gain setting (see section 3.2.1 for explanation on how to determine gain)
- 2) Measure the voltage from a blank sample for the configured gain setting.
Note: A good blank to use for this application is ultra pure or deionized water.
- 3) Use a standard of known concentration and create a correlation between the standard’s concentration and its voltage output

Cyclops Submersible Sensor

- 4) Once a correlation has been made, use the following equation to calculate concentration values for sample measurements for the calibrated gain:

$$C_{\text{Sample}} = [(C_{\text{Std}})/(\text{Volts}_{\text{Std}} - \text{Volts}_{\text{Blank}})] * (\text{Volts}_{\text{Sample}} - \text{Volts}_{\text{Blank}})$$

C_{Std} = Concentration value of standard used for calibration

C_{sample} = Concentration of sample

$\text{Volts}_{\text{Std}}$ = Voltage reading from standard concentration

$\text{Volts}_{\text{Sample}}$ = Voltage reading from sample(s)

$\text{Volts}_{\text{Blank}}$ = Voltage reading from blank

Cyclops Submersible Sensor

4. Turbidity Cyclops

4.1 Introduction

The Turbidity Cyclops measures turbidity using an 850nm light source and detection of scattered light at a 90-degree angle which is similar to many modern day bench top turbidity meters. This unit provides a quick and accurate way to determine *in situ* turbidity, eliminating the collection and storage of samples and minimizing the potential error associated with sample handling and processing.

4.2 Calibration

Calibrating the Turbidity Cyclops is a simple process requiring the use of calibration standards. Turner Designs recommends purchasing [Amco Clear Analytical Turbidity Standards](#) for non-ratio instruments because these standards are non-toxic safe solutions consisting mainly of deionized water that comes prepared in a broad range of concentrations and has a shelf life guaranteed for one year. The Turbidity Cyclops can be calibrated using a single calibration standard which correlates the concentration to the voltage measured for that specific standard:

- 1) Connect the Turbidity Cyclops to a power source and set the Turbidity Cyclops to a gain setting (see “Setting the Gain” section 3.2 for explanation on how to set the gain)
- 2) Measure the voltage from a blank sample for the configured gain setting.
Note: A good blank to use for this application is ultra pure or deionized water.
- 3) Use a turbidity standard of known concentration (NTU) and create a correlation between the standard (NTU) and its voltage output
- 4) Once a correlation has been made, use the following equation to calculate turbidity values for sample measurements for the calibrated gain:

$$NTU_{\text{Sample}} = [(NTU_{\text{Std}})/(\text{Volts}_{\text{Std}} - \text{Volts}_{\text{Blank}})] * (\text{Volts}_{\text{Sample}} - \text{Volts}_{\text{Blank}})$$

NTU_{Std} = Concentration value of standard used for calibration

NTU_{Sample} = Concentration of sample

$\text{Volts}_{\text{Std}}$ = Voltage reading from standard concentration

$\text{Volts}_{\text{Sample}}$ = Voltage reading from sample(s)

$\text{Volts}_{\text{Blank}}$ = Voltage reading from blank

Cyclops Submersible Sensor

5. Maintenance and Warranty

5.1 Maintenance

5.1.1 Rinsing

The Cyclops should be rinsed or soaked in fresh water following each deployment, ideally until it is completely clean again.

5.1.2 Care for the bulkhead connector

A light coat of Silicone spray should be used on the rubber of the male pins of the bulkhead to aid in sealing. The manufacturer recommends 3M™ Silicone Lubricant Spray or Loctite 8021 spray. **Note: You should avoid using silicone grease. Do NOT use WD-40, it will destroy the connectors.**

5.1.3 Care for the optics

The optical window should be visually inspected after each deployment following a soaking in fresh water. If cleaning is needed, use optical tissue to clean the window with soapy water.



Note: The Cyclops should NOT come in contact with any organic solvents (i.e. acetone, methanol) or strong acids and bases.

The UV Cyclops models are the **ONLY** Cyclops sensors that can be calibrated with Quinine Sulfate standards made in Hydrosulfuric Acid. All other Cyclops models **CANNOT** be used in Hydrosulfuric Acid.

5.2 Warranty Terms

Turner Designs warrants the Cyclops and accessories to be free from defects in materials and workmanship under normal use and service for a period of 12 months from the date of shipment from Turner Designs with the following restrictions:

- Turner Designs is not responsible for replacing parts damaged by accident or neglect. Your instrument must be installed according to instructions in the User's Manual. Damage from corrosion is not covered. Damage caused by customer modification of the instrument is not covered.
- This warranty covers only Turner Designs products and is not extended to equipment used with our products. We are not responsible for accidental or consequential damages, except in those states where this limitation is not allowed. This warranty gives you specific legal rights and you may have other rights which vary from state to state.
- Damage incurred in shipping is not covered.

Cyclops Submersible Sensor

5.3 Warranty Service

To obtain service during the warranty period, the owner shall take the following steps:

1. Write, email or call Turner Designs Technical Support and describe as precisely as possible the nature of the problem.

Phone: 1 (877) 316-8049

Email: support@turnerdesigns.com

2. Carry out any adjustments or tests as suggested by Technical Support.
3. If proper performance is not obtained you will be issued a Return Materials Authorization number (RMA) to reference. Package the unit, write the RMA number on the outside of the shipping carton, and ship the instrument, prepaid, to Turner Designs. If the failure is covered under the warranty terms the instrument will be repaired and returned free of charge, for all customers in the contiguous continental United States.

For customers outside of the contiguous continental United States who purchased equipment from one of our authorized distributors, contact the distributor. If you purchased directly, contact us. We will repair the instrument at no charge. Customer pays for shipping, duties, and documentation to Turner Designs. Turner Designs pays for return shipment (custom duties, taxes and fees are the responsibility of the customer).

5.4 Out-of-Warranty Service

Follow steps for Warranty Service as listed above. If Technical Support can assist you by phone or correspondence, we will be glad to, at no charge. Repair service will be billed on a fixed price basis, plus any applicable duties and/or taxes. Shipment to Turner Designs should be prepaid. Your bill will include return shipment freight charges.

Address for Shipment:

Turner Designs, Inc.
845 W. Maude Ave.
Sunnyvale, CA 94085

Cyclops Submersible Sensor

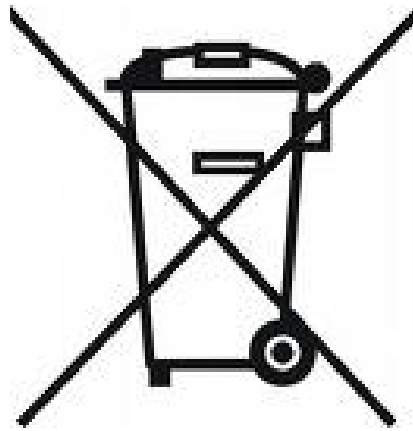

Cyclops Submersible Sensor

Appendix A: Specifications

Parameter	Specification
Linearity (full range)	0.99 R ²
Power Draw	@ 3V: Max 360 mW ≥ 5V: Max 265 mW
Input Voltage	3 – 15 VDC
Signal Output	0 – 5 VDC Analog
Temperature Range	Ambient: 0 to 50 °C Water Temp: -2 to +50 °C
Light Source	Light Emitting Diode
Excitation Wavelength	Visible – Chl, RWT, PC, PE, F UV – CDOM / FDOM, Oil, OB, RF, PTSA IR – Turbidity
Detector	Photodiode
Detection Wavelength	300 – 1100 nm
Warm up time	5 seconds
Housing Material - Cyclops-7	(Standard) 316 Stainless Steel (Optional) Titanium (Optional) Plastic
Housing Material - Cyclops-6K	Titanium
Dimensions - Cyclops-7	Stainless Steel and Titanium L: 4.3 in., 10.9 cm; D: 0.875 in., 2.22 cm
	Plastic L: 4.3 in., 10.9 cm; D: 1.25 in., 3.175 cm
Dimensions - Cyclops-6K	L: 6.6 in, 6.76 cm; D: 1.75 in, 4.45 cm
Depth Rating - Cyclops-7	600 meters
Depth Rating - Cyclops-6K	6000 meters
Weight - Cyclops-7	5 oz; 160 gm
Weight - Cyclops-6K	22 oz; 620 gm

Cyclops Submersible Sensor

Appendix B: Recommended Measurement Practices

Recommended Lab Practices for Measurements

The following steps will improve the accuracy and repeatability of your measurements, especially at low concentration levels:

1. Use a non-fluorescent container for your water samples. **Note: Plastic may fluoresce and interfere with the sample's fluorescence.**
2. If using a glass container, place the container on a non-reflective black surface.
3. Ensure that the sensor is more than 3 inches above the bottom of the container.
4. Ensure that the sensor is in the center of the container and has more than 2 inches clearance between the circumference of the sensor and the inside surface of the beaker.

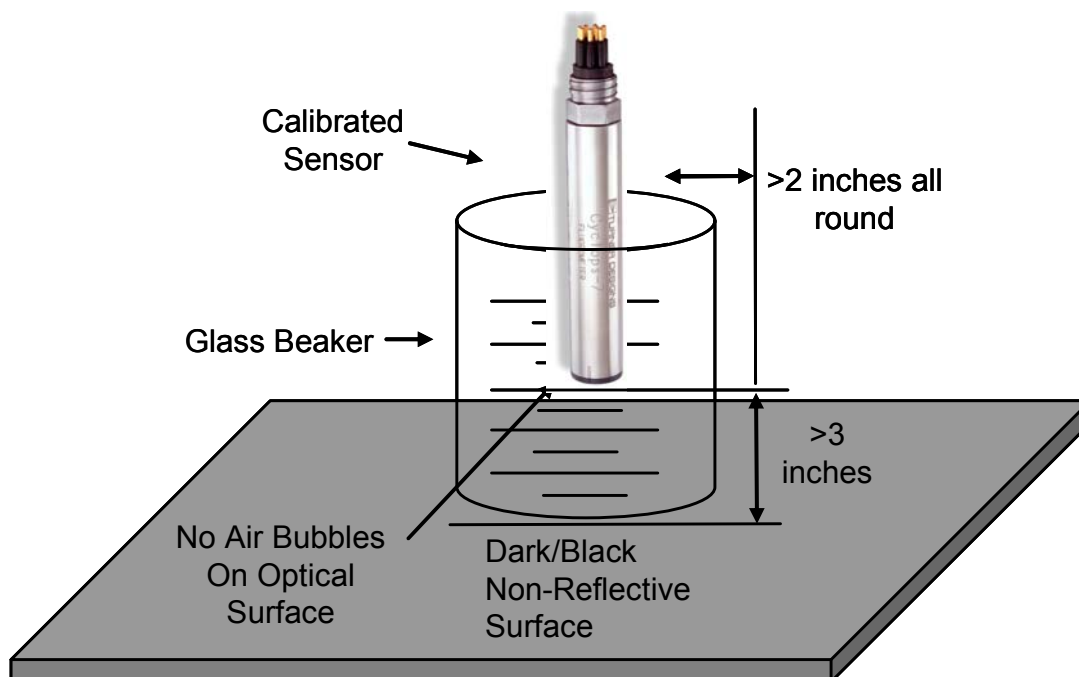

Cyclops Submersible Sensor

Appendix C: Wiring Guide

Cyclops-7 Wire	Pin Number	Function	Connection
Red	1	Supply Voltage 3 – 15 VDC	PSU – Positive Connection
Black	2	Supply Ground, 0VDC	PSU – Ground Connection
White	3	Signal Out to data logger “+” 0 – 5VDC	Multimeter Positive Connection
Green	4	Analog Ground “-”, 0 VDC	Multimeter Negative Connection
Blue	5	X10 Gain, (Medium Sensitivity)	See table below
Brown	6	X100 Gain, (High Sensitivity)	See table below

Gain Switching Table

Gain 10 (Blue)	Gain 100 (Brown)	Gain	Chl Range ($\mu\text{g/L}$)	RWT Range (ppb)	TRB Range (NTU)
Not connected	Not connected	X 1	0 - 500	0 – 1,000	0-3000
Connected to analog ground	Not connected	X 10	0 – 50	0 - 100	0-1000
Not connected	Connected to analog ground	X 100	0 – 5	0 - 10	0-100

Cyclops Submersible Sensor

Appendix D: Pigtail Cable and Connector Information

Dimension details of 24" length cable with 20 gauge colored lead wire, connects to 6 pin male connector. (Cable manufacturer/Part No: IMPULSE/MCIL-6-FS)

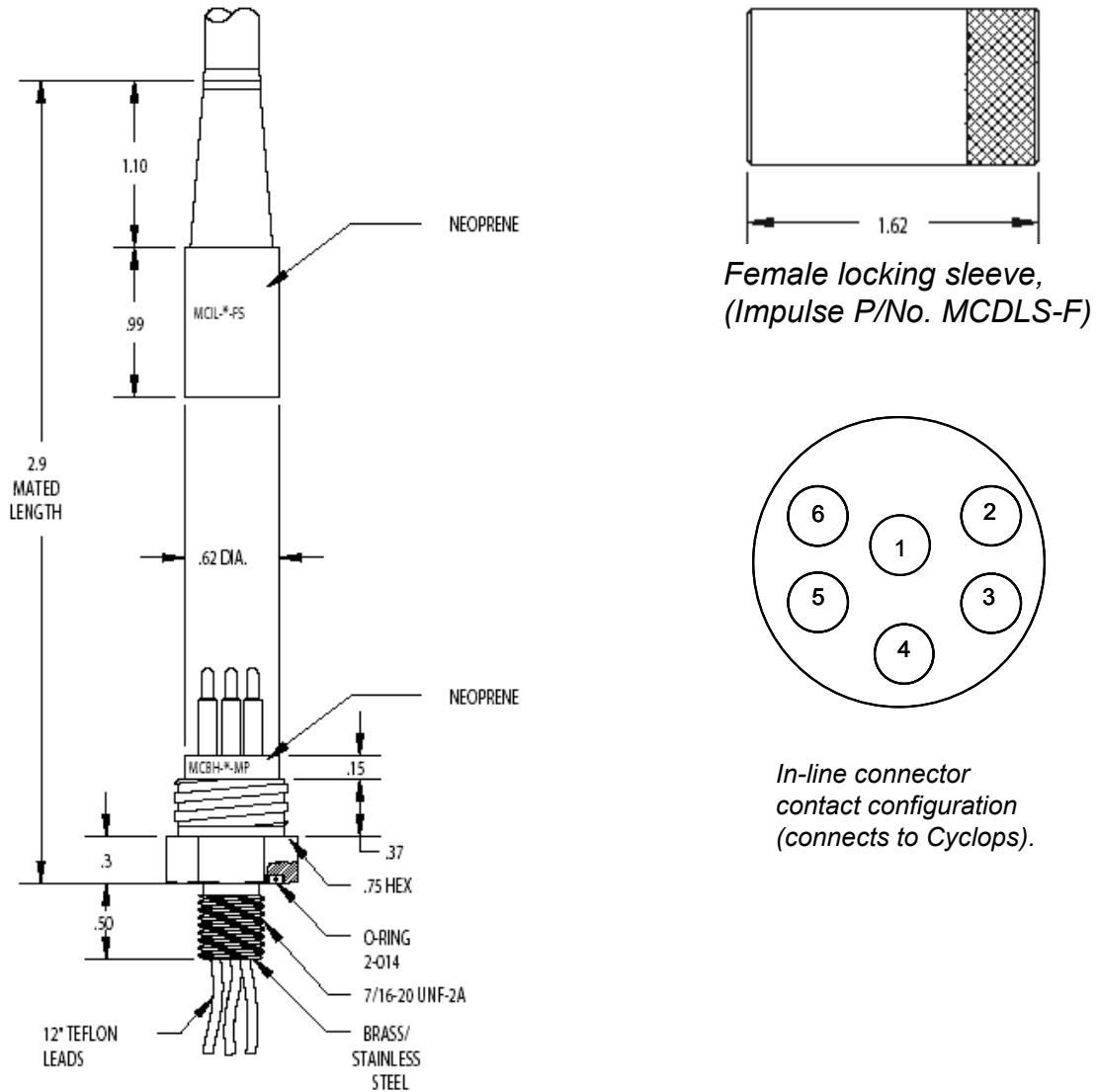

A maximum cable length up to 300 meters can be connected to the Cyclops if the following conditions are met:

- 1) The cable is shielded and contains 20 gauge conductor size or greater (i.e. Beldon No. 8426 cable).
- 2) The 0-5 volt Analog output is connected to a device (i.e. Data Logger) with an input impedance of 1 MegOhm or greater.
- 3) The supply Voltage to the Cyclops is between 5 and 15 volts.

Cyclops Submersible Sensor

Appendix E: Controlling the Gain

The operating range can either be set to one of the 3 available ranges, which will be referred to as "Static Gain Control", or it can be dynamically changed to achieve the optimum operating range, referred to below as "Dynamic Gain Control". The first approach is applicable when using the Cyclops as a stand-alone sensor. The second approach is applicable when the Cyclops is integrated into a system with control capability.

Both methods are implemented by grounding "driving Low" the appropriate gain control pin. The X10 and X100 gain control pins are normally in a "High" state if they are not connected to anything. This means the Cyclops default is the X1 gain (largest concentration range) mode. The Cyclops can be put into higher gain, lower concentration range modes, by connecting either the X10 or X100 pin (**but not both at the same time**) to ground.

Method 1 - Static Gain Control

Connect the X10 or X100 pin to the analog ground pin of the Cyclops pigtail connector. See the Gain Switching Table in Appendix C to determine the required configuration for desired gain/measurement range. See Appendix D for Pigtail Cable and Connector information. Also, see "Setting the Gain" section 3.2 for more information on "Static Gain Control".

Method 2 - Dynamic Gain Control

If you have a Data Collection System (DCS) that has programmable outputs you can use them to control the Cyclops gain settings. Following are three common output types found in DCSs and how to connect them to the Cyclops. Refer to your DCS manual to determine which is appropriate. (For those who want technical data: the Cyclops's X10 and X100 gain control pins are connected internally to the input of a Schmitt trigger inverter, part number 74LVC1G14, and a 100K ohm pull-up resistor. Both use a 5-Volt power supply.)

Output type 1: Digital Signals

Logic signals can be used to drive the gain control pins. In most cases you can connect the digital signal output of the DCS directly to the Cyclops gain control pins. To drive them high, the voltage should be 3 VDC min – 5 VDC max. To drive them low, the voltage should be 1 VDC max – 0 VDC min. You may need to connect the Cyclops analog ground to the DCS ground.

Output type 2: Open Collector Signals

This type of output is either open or connected to ground. Connect the Cyclops gain control pins directly to these outputs. You may need to connect the Cyclops analog ground to the DCS ground.

Output type 3: Relays

Relays act as a controllable switch. Connect one end of the relay to the Cyclops analog ground. Connect the other end of the relay to the Cyclops gain control pin.

Cyclops Submersible Sensor

Appendix F: Linear Range, Quenching and Temperature Considerations

The linear range is the concentration range in which the fluorometer's output is directly proportional to the concentration of the signal. The linear range begins with the smallest detectable concentration and spans to an upper limit (concentration) that is dependent upon the properties of the material, filters used, and path length.

A non-linear relationship is seen at very high concentrations where the signal does not increase at a constant rate in comparison to the change in concentration (see figure below). At even higher concentrations, the signal will decrease even though the sample concentrations are continuing to increase. This effect is known as "signal quenching".

Linearity can be checked by diluting a sample 1:1 or some other convenient ratio. If the sample is still in the linear range, the reading will decrease in direct proportion to the dilution. If the reading does not decrease in direct proportion to the dilution, or if the reading increases, the sample is beyond the linear range.

Temperature Considerations

Fluorescence is temperature sensitive. As the temperature of the sample increases, the fluorescence decreases. For greatest accuracy, record the sample temperature and correct the sensor output for changes in temperature.

For further information on how temperature, light, water quality and the physiological state of the algal cells can all affect the measurement of chlorophyll, please refer to the application section of Turner Designs' website.

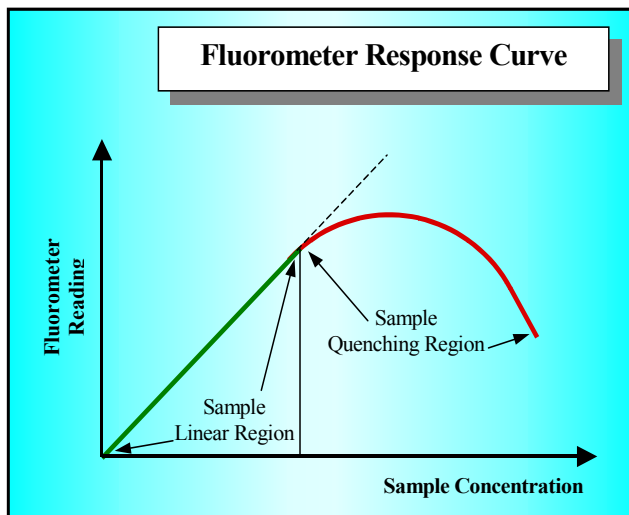

Graph showing Linear and Quenching Regions of the sample's response

Cyclops Submersible Sensor

Appendix G: Using the Cyclops Submersible Sensor with the DataBank

Cyclops sensors are analog output devices that produce a 0 – 5 volt signal that is proportional to the fluorophore being measured. Turner Designs offers the DataBank, a universal handheld meter, datalogger, and power supply that can be used to maximize performance of Cyclops sensors with functions such as:

- Auto gaining
- User defined calibrations
- Large internal memory
- Interval logging

The DataBank comes with intuitive GUI software that allows users to easily calibrate, set up logging, download data, and define parameters and values necessary to help configure the Cyclops for a specific application or study. Available options include GPS capability, external power, travel case, and car charger.



DataBank uses for different sampling protocols:

Multiple Site Measurements – measure fluorescence at different locations within your water system or across many systems; GPS enabled units provide latitude/longitude data per location

Profiling – purchase extended cables to allow for vertical profiling

Monitoring – deploy the Cyclops to a fixed location or depth and monitor the signal over time; set up logging to capture a signal within a specific time frame; download data while the sensor is deployed and continuously measuring; set up digital data output via HyperTerminal

For any application or sampling protocol, the DataBank facilitates and maximizes performance of all Cyclops sensors allowing versatility and flexibility in calibration, setup, and measurement.

Connecting the Cyclops to Turner Designs' DataBank:

Simply connect the bare wires from the Cyclops's pigtail to the DataBank board as shown below and move the switch to select **dV**.

