



Absorption and Attenuation Meter

ac-9

User's Guide

WET Labs, Inc.
P.O. Box 518
Philomath, OR 97370
541 929-5650
www.wetlabs.com

Attention!

Return Policy for Instruments with Anti-fouling Treatment

WET Labs cannot accept instruments for servicing or repair that are treated with anti-fouling compound(s). This includes but is not limited to tri-butyl tin (TBT), marine anti-fouling paint, ablative coatings, etc.

Please ensure any anti-fouling treatment has been removed prior to returning instruments to WET Labs for service or repair.



ac-9 Warranty

This unit is guaranteed against defects in materials and workmanship for a period of five years after the original date of purchase, providing the unit is returned for servicing once per year. If the unit is not returned for servicing before the end of the first year of ownership, the warranty will be one year.

WET Labs will supply all replacement parts and labor and pay for return via 3rd day air shipping in honoring this warranty. This warranty is considered void if the factory determines that the unit was subjected to abuse or neglect beyond the normal wear and tear of field deployment, or in the event the pressure cans have been opened by the customer. The customer should call for a Return Manufacturer's Authorization (RMA) before returning the instrument to the factory and is responsible for shipping costs to WET Labs. WET Labs is not responsible for shipping damage done during the return shipment. WET Labs assumes no liability for equipment damage, personal injury or loss of data resulting from use of this instrument, except for that stated in this warranty.

Table of Contents

1.	Operation	1
1.1	Installing WETView	1
1.2	Bench Testing	2
1.3	Air Tracking.....	3
1.4	Cleaning.....	3
1.5	System Requirements.....	4
1.6	Operating the Meter	6
2.	Instrument Description	12
2.1	Instrument Overview	12
2.2	Optics.....	14
2.3	Electronics.....	16
2.4	Pressure Housing Material.....	16
2.5	Signal Processing.....	16
3.	Data Processing	18
3.1	Analog Acquisition.....	18
3.2	Analog-to-Digital Conversion	18
3.3	Digital Processing and Data Output.....	18
4.	Calibration and Characterization	27
4.1	Temperature Correction.....	27
4.2	Precision.....	27
4.3	Absolute Calibration	28
4.4	Linearity and Dynamic Range	28
4.5	Air Calibration and Tracking.....	28
5.	Specifications	31
5.1	Connectors	31
5.2	Power Requirements	33
6.	References.....	34
Appendix A:	Optional Connectors	35
Appendix B:	Pressure Sensor Use and Care	37

1. Operation

This section provides an introduction to the ac-9 and describes how to perform air tracking and bench testing prior to deploying the ac-9.

The ac-9 is delivered in a sturdy wooden shipping container with the following components:

- ac-9, with one absorption flow tube and one attenuation flow tube
- four flow sleeves
- four protective black plastic caps
- dummy plug with lock collar
- this manual
- ac-9 Protocol Document
- WETView User's Guide
- WETView software and instrument-specific calibration information
- Ten-foot test cable
- double "Y" de-bubbler tubing
- stainless steel intake screens

Familiarize yourself with the ac-9: remove the black plastic flow tubes by grasping the flow tube sleeves and sliding them away from the ends of the flow tube (toward the middle of the flow tube). You only have to slide the collars about ½ in. to unlock the flow tube from its fixed position. The flow tube will lift out, exposing the transmitter and detector windows on the lower and upper flanges respectively. Observe the flow tubes. The attenuation tube is different from the absorption tube. Its flow chamber is plastic and the two sleeves on the tube are identical. This tube installs on the 'c' side of the instrument (the side with the identical looking windows). The 'c' tube has no "up or down" orientation. The absorption tube is lined with a quartz tube and one of the two sleeves is flat on top (the lip present on all the other sleeves is missing). This tube installs on the 'a' side of the instrument, which can be identified by the 'a' detector on the upper flange and is the only window, which is clearly different from the other three. The flat flow tube sleeve goes on this detector.

You may want to mark the tubes and their orientation with tape or marking pen before using the instrument at sea so that there is no confusion on reinstalling the tubes after cleaning the optics. Reinstall the flow tubes before bench testing your instrument. If you have removed the plastic caps from the stainless nozzles, replace them at this time.

1.1 Installing WETView

WETView displays data produced by WET Labs instruments. It runs on PC-compatible computers with at least 16 Mb of memory and 3 Mb free hard disk space.

1. Place the WETView floppy disk in the floppy disk drive.
2. Open the floppy and double-click on the SETUP.EXE icon. Setup will guide you through the rest of the installation process.

When installed, the following files should be on the hard disk: WETVIEW.EXE, WETVIEW.UIR, AC9XXX.DEV, AIRXXYYY.CAL. The .DEV and .CAL files are the calibration files for your particular instrument.

Caution

If you have old device files from previous calibrations, you should rename them or archive them in a different directory so that they will not be overwritten.

1.2 Bench Testing

The following items are needed to bench test the ac-9:

- A clean, solid lab table or work bench
 - The ac-9 with 10-foot test cable (or sea cable)
 - A 12–15 volt power supply (the ac-9 requires 10–18 VDC)
 - A PC with WETView installed.
1. Connect the test cable to COMM1 or COMM2 of the computer. Connect the power leads to a 12–15 volt power supply. The black lead is the V+ lead. Before connecting the cable to the instrument, use a multi-meter to check the input power.
 2. Connect the ground probe to pin 1 on the pigtail connector (the large pin as you are looking into the connector). Connect the hot probe to pin 4 (the pin directly opposite from pin 1). You should measure 12–15 volts across these two pins.
 3. Turn the power supply off.
 4. Connect the pigtail to the instrument. Pin one, marked on the outside of the connector by a small rubber bump, engages the large socket on the instrument's bulkhead connector. Push the connector straight on to avoid damaging the pins. Apply power to the instrument and allow it to begin warming up.
 5. Run WETView. When the interface is displayed, you will need to provide a .DEV file name. Click on the <O> button in the center top of the screen or choose "Open Device File" from the File Menu at the top left of the screen. The program will ask you to choose the proper COMM port. Select COMM1 or COMM2 as appropriate. Note that WETView supports COMM1 through COMM4 only.
 6. Click on the center button or <F1> to start displaying data. After 5–10 seconds, tabular data should be displayed on the right side of the screen. A real time graph will begin to develop, depending on the graph parameters set at the time. Refer to the WETView User's Guide for details of running the WETView software.
 7. After a short time, again click on the center button that will stop the data collection and ask for a file name to apply to the data if you should want to archive it. Press ESC if you do not want to save the data. To quit the program, choose QUIT from the File menu. At this point you have successfully completed a bench test of the instrument.

1.3 Air Tracking

We provide an air calibration (.CAL) file similar to the device (.DEV) file and can be applied in WETView in the same manner. The DEV file provides the clean water offsets so that when measuring clean, fresh water, the instrument's output should be very nearly 0.0 for all channels. The .CAL file provides the offsets that provide 0.0 values when the instrument is clean and dry and measuring air values. This is a useful tracking tool for catching instrument drift, filter aging and improper cleaning.

When you installed WETView, the latest air .CAL file should have been transferred to your WETVIEW directory. The name of the file takes the form:

AIRXXYYY.CAL where XX is the calibration number; YYY is the instrument number.

When a .DEV file is opened in WETView, it will display *.DEV in the dialog box, which will list all the .DEV files on the default drive. If you change the *.DEV to *.CAL, the available .CAL files will be displayed. Select the latest .CAL file and start collecting data. Make sure the black plastic caps are installed on the flow tube nozzles so no ambient light can enter the flow tubes. If the instrument is clean and dry, the values displayed in WETView should be very close to 0.0 (within 0.005–0.01). If the values are within this range, the instrument is clean and ready to deploy. If the values are outside this range, the first step is to re-clean the instrument and then reapply the .CAL file offsets.

1.4 Cleaning

1. Remove flow tubes and all O-rings. Remove the collars from the flow tubes. Wash with a mild detergent diluted with distilled, reverse osmosis-filtered (RO) or de-ionized (DI) water to gently wash all of the windows and rinse the flow tubes. Use Kimwipes or other lint-free tissues to wash the windows. Rinse off the meter completely with water to ensure no soap residue is left inside the flow tubes or on the windows.
2. Dry the meter. Place the instrument in a protected area where it can dry completely. Using a small heater to blow warm air over the meter may help speed the process. Using dry nitrogen to blow-dry the meter and remove water from the small grooves around the windows will also help speed the process. It is suggested that the instrument be left overnight to dry out completely. Reassemble the meter. Carefully replace O-rings and slide collars back on to the flow tubes. Replace O-rings around the windows.
3. Clean windows using a Kimwipe or lens paper. Place a couple of drops of methanol or ethanol on the Kimwipe. With firm pressure, gently wipe the windows with methanol. This should remove any visible streaks on the windows. If necessary, follow with a dry wipe in one direction across the window face. Blow off any lint or dust with a dry air source.
4. Clean the flow tubes by putting a few drops of methanol on a Kimwipe and, using a wooden dowel rod, carefully slide the Kimwipe through the flow tube. Repeat this procedure with both flow tubes. Examine each flow tube when you are through to ensure there are no streaks or small pieces of lint left on the inside of the flow tube.

5. Dry the windows. Since small amounts of moisture can affect the air readings, it is important to ensure the meter is completely dry. Using nitrogen to blow dry the windows immediately before replacing the flow tubes works very effectively. This will remove any water or methanol trapped in the small grooves around the window.
6. Replace the flow tubes. Carefully slide the flow tubes into place without sliding dirt across the windows. Slide the sleeves up around the windows and over the O-rings, making certain they are firmly in place and aligned correctly. Use small black caps, or black electrical tape, over each of the nozzles on the flow tube to provide a dark environment and to keep the meter clean and free of moisture while obtaining data.
7. Turn the meter on and allow it to warm up for at least 15 minutes. When the meter is stable you should be able to collect 10 minutes worth of data and the values should not vary more than 0.005 m^{-1} over the 10-minute time period.
8. Collect data. Record a one- to two-minute file and save data. Repeat steps 4–6 until you can collect three data files, cleaning after each file, such that the average values for each channel vary by no more than 0.005 m^{-1} .

The meter is calibrated over a specific range of internal temperatures (refer to your calibration sheet). If the meter's internal temperature is higher than the maximum calibration range, it may be operating out of spec. Setting the meter in a shallow pan of water (immerse most of the lower can) can help keep the instrument cool. This process should be repeated until the air values are within specification. This may take three or more iterations but is very important to be done carefully before taking your instrument to sea. The air calibration procedure should be done again at the end of a cruise or data collection period to track the instrument's performance over time.

1.5 System Requirements

This section explains the basic system components necessary to operate the ac-9. If you are using the instrument in a standard profiling configuration, you will generally need the components described below. Other configurations, such as mooring and underway flow-through systems, will require additional components such as battery packs, data loggers, anti-fouling canisters and/or de-bubblers. Test cables, software, and system configuration engineering may be obtained by calling WET Labs. Alternatively, you will find additional information about the various system components in the Technical Reference Section of this manual. This manual concentrates on the use of the ac-9 as an optical profiling instrument.

The ac-9 was designed for easy use. However, certain system requirements for power and communication with the instrument must be met. Figure 1 shows a block diagram of the basic system components required for instrument operation. An explanation of these various components follows the diagram. More detailed information on most of the system, the instrument, and data output format can be found in the Technical Reference Section of this manual. Details about hooking the unit up and acquiring data are included in this section.

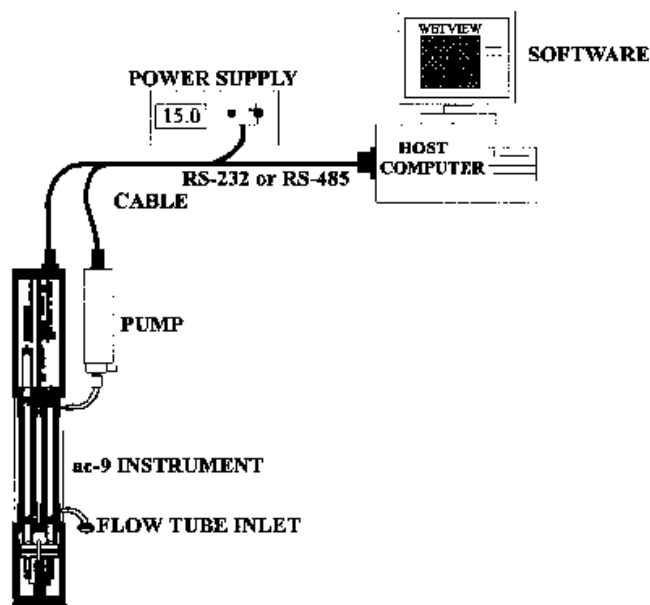

Figure 1. Typical ac-9 configuration

Required system components include:

Instrument

The ac-9 and its flow tube assembly form the basic optical sensor.

Pump

The flow-through system will typically require an ancillary pump in order to assure proper operation. Pump requirements depend upon desired flow rates, required depth of operation, power availability, and existing hardware.

Cabling

The ac-9 requires a minimum of four conductors for power and RS-485 output. (Three conductors for RS-232 output).

Power Supply

The ac-9 requires a 10–18 VDC supply, capable of providing a minimum of 9 watts continuous output. If a longer cable is used, power losses must be accounted for in determining the power supply voltage and power requirements.

Serial Communications

Data from the ac-9 is transmitted via both RS-232 and RS-485 depending on which sockets are connected to the instrument's bulkhead connector. The exact configuration is described in your instrument's configuration in Section 5.1. Regardless of the mode of transmission you use, you must have a serial interface on your computer or data logger capable of accepting data from the instrument. If you have an instrument with RS-485 output and are using a computer with standard RS-232 communication ports, an optional protocol converter can be readily obtained (one such converter is manufactured by B&B Electronics—model number of 485COSR).

Host/Data Logger

The ac-9 can be interfaced to any computer or data logger capable of supporting a 19,200 baud rate serial interface. If you plan to use our WETView software acquisition package you will need a Pentium® class IBM-compatible computer running Windows 95, Windows 98 or Window NT to support the software package.

Software

The WETView host software package interfaces directly to the ac-9 via your computer serial port. WETView allows real-time graphical visualization of the data in any of several ways such as a function of time, depth or wavelength. WETView automatically applies calibration constants, temperature corrections and generates a tab-delimited ASCII text file that can be imported into programs such as Excel or MatLab for post processing or manipulation. The data output format of the ac-9 is defined in the Technical Reference Section of this manual.

1.6 Operating the Meter

1.6.1 Basic Power On

- a. **Check wiring of cable.** Make sure the “+” lead of the test cable is connected to the “+” terminal of your power supply. Make sure the “-” lead of the test cable is connected to the “-” terminal of your power supply. Verify that your power supply is providing between 10 and 18 VDC, and is rated for at least 2 amps. See section 3.1 for details of connector wiring.

WARNING

Power input on this unit is diode-protected from reverse polarity power-up, but this is not 100 percent insurance against damaging the meter, nor will it protect it from over-voltage.

- b. **Cable connections.** The surface (dry) end of the cable should have terminations for an RS-232 connection into the computer and leads that connect to a power supply. Attach the power leads to a stable power source that supplies 10–18 VDC to the ac-9. Make sure the polarity is correct before switching on the power supply. Connect the RS-232 connector to the desired serial port of the data collection computer. If your instrument is sending data in the RS-485 format, an RS-485 to RS-232 converter is required to allow proper operation. Plug the submerged (wet) end of the cable into the ac-9. Applying a small amount of silicone grease or equivalent to the base of the instrument bulkhead makes the plug insertion easier and provides greater assurance of a good seal. Use a connector lock ring if one is available.
- c. **Turn on power supply.** To verify basic operation when not hooked directly to a computer, remove one of the flow tubes and, in a darkened environment, place a white piece of paper into the beam path. You should be able to see the beam image on the piece of paper. You should be able to hear a faint whirring of the filter wheel motor if you place your ear directly against the lower can. If you neither hear the motor nor see the beam, the unit is not working. In this case, check your connections

and your power supply. If the instrument still does not run, you may want to seek technical assistance from the factory.

- d. **For optimum stability allow the instrument to warm up for 3–5 minutes before acquisition.** While this is not an absolute requirement, the instrument's electro-optics are subject to an initial stabilization period.

1.6.2 Mounting Meter

ac-9 operation is optimized for a vertical to forty-five degrees off-vertical orientation with the bulkhead connector facing upward (Figure 2). If your application requires a horizontal mounting, take care to provide proper pump priming and to avoid trapping air bubbles in the flow tubes. This can be accomplished by taking the system to a depth of 20 meters and allowing the required in-water warm up period to occur at depth. This helps the pump to prime properly and compresses small air bubbles, allowing them to be expelled from the ac-9.

In addition, operating the instrument in the horizontal position could potentially cause small variations in the meter's response due to the different orientation of the filter wheel's rotational plane. Therefore, we recommend that both air and water calibrations be done in the orientation in which the meter will be deployed to obtain the best results.

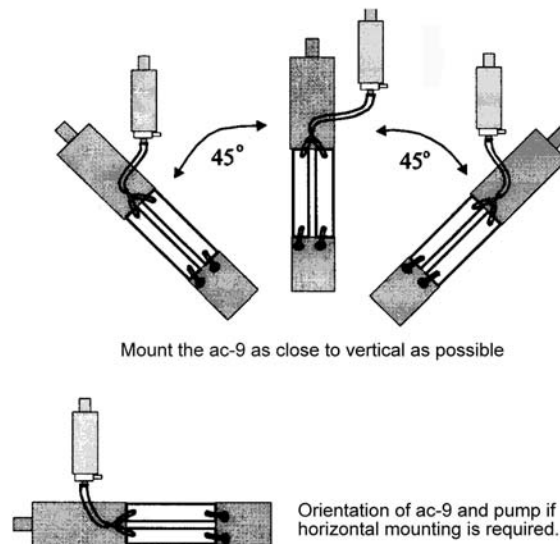

Figure 2. ac-9 mounting positions

Specific mounting instructions will depend upon implementation of the sensor. To assure long term instrument integrity and optimum operation, observe the following basic procedures:

- a. **Do not make direct contact between the ac-9 pressure housing and a metal frame or hose clamp.** The ac-9 is available in one of two pressure-housing materials. Aluminum is used for full ocean depth rated units and an acetal copolymer plastic is used for the standard units rated to 500 meters. The aluminum housing is hard anodized with a special plastic impregnation to assure minimum corrosion damage

and to provide electrical isolation from the aluminum housing and its surrounding environment. However, metal-to-metal contact with the housing can damage this coating and result in possible corrosion of the pressure case. We recommend a neoprene spacer between the unit and its frame or clamp. At the very least, any contact area should be taped carefully to assure mechanical and/or electrical isolation.

- b. **Do not apply torsional stress to the instrument housing.** The optical path is encased in a rigid housing, but is still subject to distortion if the unit is subjected to undue stress. The instrument has a delicate optical path that is subject to misalignment if stress is applied unevenly to the upper and lower cans. Make sure the unit is mounted on at least two points and that neither point is a stress point.
- c. **Make sure you have provided for an unobstructed upward flow through the flow chambers and the pump (Figure 3).**

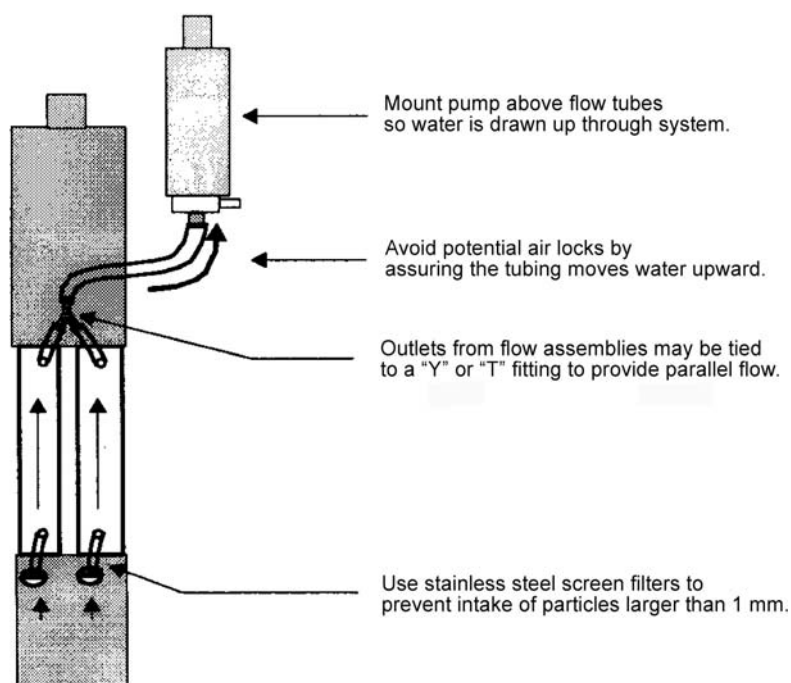

Figure 3. Proper connection of ac-9 flow tube

1.6.3 Deployment Tips

The following suggestions will help you obtain the highest quality data from your ac-9:

- The instrument is extremely sensitive and should be handled carefully.
- A sturdy shipping/transport container should be used to transport your instrument to the field. The instruments are sturdy, but the optics can be jarred out of alignment when subjected to shock.
- The data will be adversely influenced by bubbles, dirt or grease in the flow path or misalignment of the flow tubes. Make sure that the flow tubes, pump tubing and

screens are free of dirt and grease. Clean with ethanol or warm soapy water. Rinse with clean tap or distilled water. Do not allow water to dry on the windows as this will leave a residue that may be hard to remove.

- Secure the ac-9 to a sturdy cage or lowering frame that will protect the instrument from striking the deck, ship's side, or sea bed. Use a dielectric isolator (rubber sheeting or thick tape) to isolate the instrument's aluminum case from the steel cage.
- When clamping the instrument to the cage, make certain no torsional stresses are applied. Even slight wracking of the instrument can alter the beam alignment. This will severely degrade the data quality, especially on the 'c' side, which requires an extremely tight alignment tolerance.
- Once every couple of days, take a data file in air to track any instrument drift. This procedure is outlined in Section 4.5. The instrument must be very clean and completely dry in order to achieve an accurate air calibration measurement. Using compressed dry nitrogen or oil-free dry air to blow the instrument's flow tubes and windows dry will speed the drying process (see Section 4.5, Air Calibration Tracking Method).
- Upon deployment, the instrument should be lowered to just below the water's surface. Turn on the instrument and pump and check to ensure that the pump has primed and is operating properly. Lower the package to a depth of 10–20 meters. Run the instrument for 3–5 minutes to allow the motor controller to stabilize, the flow tubes to clear and the instrument to begin to equilibrate with the water temperature.
- After the warm up period, raise the package to just below the surface and begin data collection. The initial depth will be dependent on the natural surface conditions and the amount of bubbles that the ship itself is generating. Steadily lower the cage through the water column.
- The upcast can proceed immediately after the downcast. It is the user's choice whether to open a new data file for the upcast or include the down and upcast data in a single file.
- Once the cage is back to the just below the surface, stop the data collection and turn off the pump. Carefully bring the cage on deck and lash it down. Give the cage and instrument a fresh water wash down after every cast. If this is not practical, wash the instrument at the end of each data collection day. Holding a hose (low pressure) over the pump discharge port will flush the tubing and the flow tubes. Rinse the flanges and connectors. If leaving the instrument on deck for more than a few minutes, cover the cage with a tarp to avoid over-heating the instrument due to solar insolation. At the end of each data collection day, remove the tubes and carefully clean and dry both the flow tubes and windows. Failure to flush the instrument with fresh water may cause corrosion damage over time.
- For further information on deployment techniques, see the ac-9 Protocol document.

1.6.4 Data Acquisition

This section describes how to collect data from the ac-9. WET Labs offers several output configuration options to provide flexible interfacing to different systems. These various output protocols are discussed at length in the Data Processing Section of the manual. Unless supplied with a custom output protocol the instrument powers up in a free run mode. This means that when turned on the unit automatically begins acquiring data and outputting that data in its appropriate format. Typically the instrument comes supplied with RS-485 and RS-232 output operating at 19,200 baud. Consult the Specifications Section for the output format.

RS-485: For longer cable lengths and maximum data integrity, RS-485 protocol is the preferred method of data transfer. Data is transmitted from the instrument in a binary format. To view this data, you must have a program capable of reading binary data. If you are using our WETView software package, the binary read is done automatically. If you do not plan to use WETView or a WET Labs-supplied data logger, consult the Data Processing Section of this manual for a detailed description of the binary data format.

RS-232: Operating across an RS-232 cable, you can obtain binary data from the instrument. If you are using WETView, read the operational instructions contained in the software manual.

1.6.5 Care and Maintenance

Built for field deployment, the ac-9 requires minimal maintenance. However, following these simple recommendations will assure optimum data integrity as well as longer instrument life.

After a field deployment of the ac-9 you should clean the instrument prior to storage. Refer to Section 1.4 for detailed cleaning procedures. The following steps will help prolong the life of the instrument:

- a. **Pressure housing:** Begin with a thorough rinsing of the unit and its flow tubes with fresh water. If a dummy plug for the connector is available, install it on the main bulkhead connector before flushing the instrument. After rinsing, towel-dry the pressure housing and remove the flow tubes.
- b. **Windows:** The windows should be cleaned with dilute soapy water, followed by ethyl alcohol and should receive a final rinse with distilled or reverse osmosis-filtered water. This will remove any fingerprint oil, grease or other contaminants from the windows. Use lint free lens cleaning paper to avoid scratching the windows or detectors.

WARNING

Do not use acetone on the windows. It will damage the window holders.

- c. Flow Tubes:** The flow tube assemblies are integral to the optical behavior of the ac-9. They are optical components that help produce a very precise measurement, and thus they need to be dealt with accordingly. Before using, inspect both tubes and make sure they are free of stains and dust. The reflective flow tube for the absorption measurement operates using the principle of internal reflection. To maintain its reflective properties, it requires a thin air gap between the outer wall of the quartz tube and the inner wall of the surrounding sleeve. The reflective tube should be periodically checked for leaks. To determine if the tube is maintaining its reflective properties, immerse it in water and point towards a fairly light background. The inside of the tube should appear uniformly bright. If the tube has leaked, call the factory for repair instructions or tube replacement.

To clean the absorption path's reflective tube, carefully plunge an alcohol-soaked tissue through the tube, and rinse thoroughly with distilled water. Whenever plunging a tissue through the tube, use a wooden or plastic dowel to prevent scratching the sides of the tube. After rinsing, dry the tube either by blowing dry nitrogen through it or by plunging a soft tissue. The attenuation path flow tube is virtually maintenance free, except for occasional cleaning. Follow the same basic procedures supplied for cleaning the absorption path tube. Remove the flow tube sleeves when drying the flow tubes.

- d. Storage:** The ac-9 should be stored and transported in a shock-protected environment. Typically, units are shipped in a sturdy wooden crate. Using the crate will assure that you can safely transport the instrument, providing it is handled in a reasonably careful fashion.

2. Instrument Description

This section provides a general description of how the ac-9 operates. It provides a general discussion of the primary instrument configuration as well as a description of the optical and electronics system.

2.1 Instrument Overview

Figure 4 shows a diagram of the ac-9. The unit consists of two pressure housings separated by three stand-offs. The shorter of the two pressure cylinders houses the light sources, filter wheel, and transmitter optics. The longer of the two cans houses the receiver optics and the control and acquisition electronics for the unit. The absorption and attenuation beam paths and flow tube assemblies are between the receiver and transmitter housings. Power to the unit and signal out of the unit are provided via the bulkhead connector at the end of the long (receiver) housing.

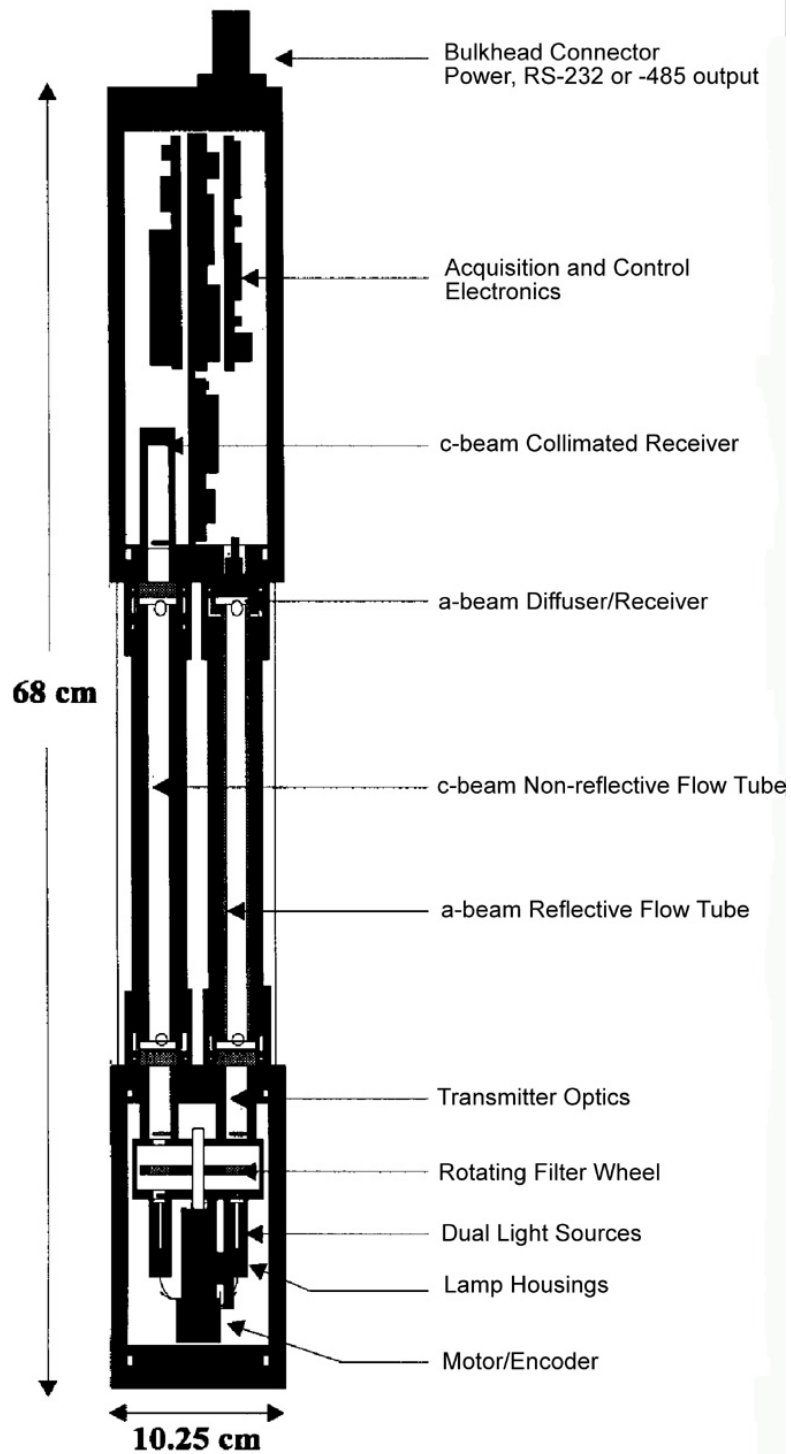
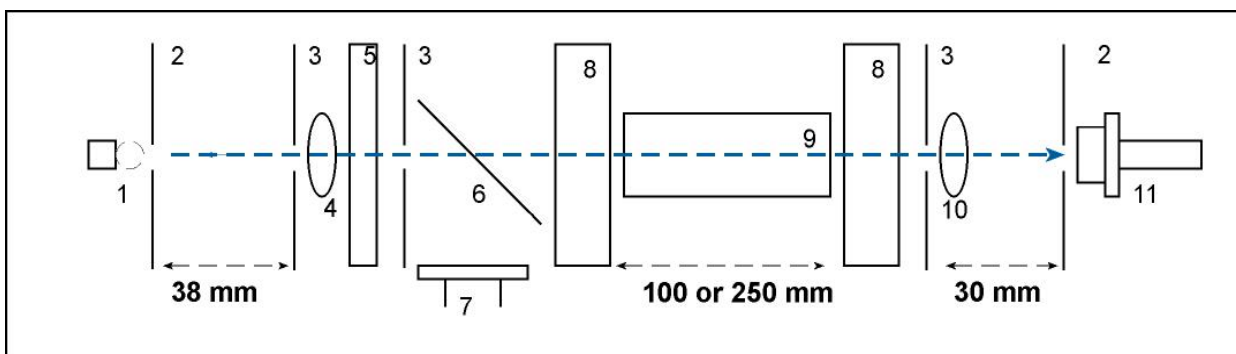

Figure 4. ac-9 diagram

2.2 Optics

The ac-9 performs concurrent measurements of the water's attenuation and absorption characteristics by incorporating a dual path optical configuration in a single instrument. Each path contains its own source, optics, and detectors appropriate to the given measurement. The two paths share a common filter wheel, control and acquisition electronics. For purposes of description, we refer to the beam performing the attenuation measurement as the **c beam** (Figure 5) and the beam used to make the absorption measurement as the **a beam** (Figure 6).

2.2.1 c Beam Optics



- | | |
|-----------------------|-------------------------------|
| 1 Lamp | 6 Beam splitter |
| 2 1 mm aperture | 7 Reference detector |
| 3 6 mm aperture | 8 6 mm quartz pressure window |
| 4 38 mm singlet lens | 9 Flow tube |
| 5 Interference filter | 10 30 mm singlet lens |
| | 11 Signal detector |

Figure 5. Optical Path Configuration for c beam

Light from a DC incandescent source passes through a 1 mm aperture. The light is then collimated with a 38 mm lens followed by a 6 mm aperture. The collimated light passes through bandpass filters mounted upon a continuously rotating filter wheel, creating a narrow band spectral output. The filter wheel holds nine 12.5 mm diameter, 10 nm full width half maximum (FWHM) filters that are spaced around the perimeter at approximately a 3:1 ratio with associated blank spaces. This configuration provides a chopped output for the detectors, which compensates for temperature coefficients in the detector and amplifier circuitry as well as providing low level ambient light rejection. Once the light has passed through the filter wheel, the beam passes through a beam splitter, creating a primary beam and a reflected beam. The reflected beam intensity is measured by a reference detector. Using a ratiometric scheme with the reference and signal detectors, we compensate for long-term lamp drift. The primary beam then passes through a pressure window into the sample water volume.

A flow tube encloses the water path. Scattered light that hits the blackened surface of the flow tube is absorbed and therefore does not contribute to the measurement of transmitted intensity. Light radiated through the flow path is therefore subject to both scattering and absorptive losses by the water.

Once through the water path, the light passes through another pressure window and then is re-focused through a 30 mm lens upon a receiver detector. A 1 mm aperture is placed directly in front of the detector, creating a 0.75-degree acceptance angle in water.

2.2.2 a Beam Optics

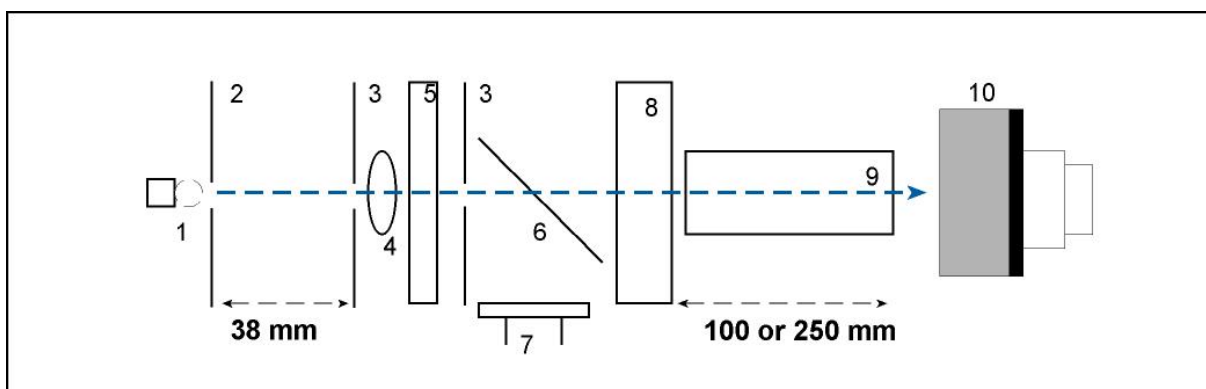

- | | |
|-----------------------|-------------------------------|
| 1 Lamp | 6 Beam splitter |
| 2 1 mm aperture | 7 Reference detector |
| 3 6 mm aperture | 8 6 mm quartz pressure window |
| 4 38 mm singlet lens | 9 Reflective flow tube |
| 5 Interference filter | 10 Diffuser/Signal detector |

Figure 6. Schematic Representation of a **beam** optics

The **a-beam** and **c beam** optics are similar. The **a beam** light is 45 degrees out of phase from that of the **c beam**. Beam splitter optics and aperturing of the beam are identical with the **c beam** source optics.

The sample water volume is enclosed by a reflective flow tube. Light passing through the tube is both absorbed by the water itself and by various pigments contained in particulate matter within the sample volume. Forward scattered light is reflected back into the water volume by the reflective tube. The light is then collected by a diffused large area detector at the far end of the flow tube.

The flow tube uses the internal reflection principle in reflecting light back into the water volume. A clear quartz tube is employed. The outer perimeter of the tube is enclosed by a thin annular volume of air. Using the Fresnel Equation, one can see that with an index of refraction of 1.33 in water and index of refraction of 1 in air, the total internal reflection is achieved to 41.7 degrees with respect to the optical axis.

With our deep units (or upon request) we employ an aluminized flow tube with an oil-filled gap that provides pressure equalization over the rated depth of the instrument.

2.3 Electronics

The primary electronic components of the spectral absorption meter include a DC/DC converter power supply, motor regulation circuitry, an optical encoder mounted on the motor, amplification circuitry for the detectors, an analog-to-digital converter, and a microprocessor controller. The filter wheel spins continuously at a nominal rotation speed determined by a pulse-width modulation circuit. The encoder breaks down a single rotation of the wheel into 512 steps. The position information from the encoder is then read by the controller. Signals from the detectors are amplified by a single stage current to voltage operational amplifier configuration. After a post gain stage used for signal level shifting, the signal is digitized by an 18-bit digital signal processing analog-to-digital converter (A/D). The A/D continuously samples the detector signals at a rate of 80 kilosamples/second. Its output is sent serially at 4 Mbaud to the controller. The controller watches the encoder output to determine when to begin reading the A/D. Once sampling begins, the controller collects and averages approximately 100 readings as a given filter scans through the light beam. The encoder once again indicates when to stop sampling and the controller then begins processing the new data. This cycle is repeated for each filter and associated blank space through the rotation of the wheel. Processed data from the instrument is then sent serially in a binary format to a host data-logging unit.

2.4 Pressure Housing Material

The ac-9 is housed in a robust pressure can made from either acetal copolymer (500 meter depth rating) or type 7075 aluminum (5,000 meter depth rating).

2.5 Signal Processing

The purpose of the ac-9 signal processing circuitry is to take a raw optical signal and make it into a physically meaningful measurement ready for output. Signals from the absorption path and attenuation path detectors go through several levels of analog and digital processing before they are registered as output from the unit. To understand the exact nature of signal processing, it is first necessary to better understand the primary data sampling. Figure 7 is a timing representation of the ac-9 signal sampling through a single filter wheel rotation, so that each of the nine interference filters are brought in line with the optical path once per revolution.

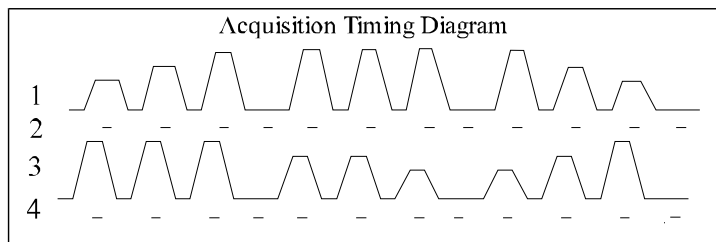

Figure 7. Acquisition Timing

Trace one represents the optical signal from the absorption detector as the filter wheel spins through its cycle. During the filter wheel rotation, signal output from the absorption detector is continuously monitored and amplified through an analog current-to-voltage amplifier circuit. The current-to-voltage amplifier serves as the primary gain stage for the signal. Typical gains for the channels are set at 5 Mb. After the primary gain stage, the signal is passed through two more analog stages for level shifting and voltage inversion. At this point, the signal is ready for digitization. The Analog-to-Digital Converter (A/D) continuously samples the incoming voltage level at a rate equal to approximately 80 kilosamples per second. The A/D runs off its own clock and is, in effect, autonomous from the rest of the system. The CPU determines when to sample the A/D.

Trace two shows the sampling periods in which the CPU obtains signal from the A/D. Input from the motor encoder tells the unit when the source beam is either within a given filter's clear aperture or completely blocked. The CPU sampling period on the A/D is about 3 msec. It only samples in the middle of the filter's aperture. This means that at a 6 Hz rotation speed the CPU samples and averages about 100 samples per filter or blank per pass. Both the signal and reference detectors are sampled simultaneously during this period. Once averaged, the dark values are then subtracted from the raw light values in order to create a given datum point:

$$C_{sig} = C_{sig_{light}} - C_{sig_{dark}}$$
$$C_{ref} = C_{ref_{light}} - C_{ref_{dark}}$$

The light sample period and the dark sample period are separated by 0.013- to 0.027-second interval depending upon the rate of filter wheel rotation. This interval defines the limiting frequency response of the electro-optical signal processing within the unit.

Trace three shows the analog signal from the attenuation detector. The absorption and attenuation beams are located 45 degrees out of phase with respect to each other, in order to provide optimum switching and sampling by the CPU. Trace four shows sampling of the attenuation signal. Input from the primary gain stages is switched into the subsequent processing stages by the CPU. Thus, processing for the 'a' and 'c' channels remains virtually identical.

The CPU collects and buffers one revolution of raw signal data and then begins to output the data as it is sampling the next revolution. Reference data is stored and accumulated for ten revolutions, since its primary purpose is to compensate for long-term drift. After ten revolutions, the reference channel data is sent along with a temperature reading, depth (optional) and other status information.

3. Data Processing

Data from the ac-9 is acquired and processed through the following steps.

3.1 Analog Acquisition

Optical radiation at the reference and signal channels is continuously monitored by operational amplifiers operating in a current to voltage configuration. The amplifiers are configured for a gain of $5 * 10^6$.

3.2 Analog-to-Digital Conversion

The A/D used in the ac-9 maintains a two-channel input. Between the attenuation beam reference and signal channels and the absorption beam reference and signal channels there are four total channels to sample. To meet this requirement, an analog switch is placed after the primary gain stage of the inputs. During a single filter wheel rotation, the switch alternates input into the A/D. Signal and reference detectors for a given beam are sampled simultaneously by the A/D. The switch alternates readings between the absorption and attenuation paths. The CPU reads the two A/D channels and controls the analog switching based on encoder information from the motor that defines the exact filter wheel location.

3.3 Digital Processing and Data Output

The CPU takes multiple samples of both signal and reference channels, accumulates them through the sampling period, and then averages the values at the end of the sampling period. Once averaged light and dark values are collected for each channel, the CPU takes the difference of these values to derive its output value. Reference values are subsequently averaged for ten filter wheel scans. Once signal data is accumulated over a given filter wheel rotation it is output is transmitted through the RS-232/RS-485 port. Every ten rotations, the CPU sends averaged reference values as well as temperature and status information. The data output is sent as raw 24-bit hexadecimal averaged values representing A/D counts (Hex 0 = FFFFFFF).

3.3.1 Data Format

The table below shows a serial output record from the ac-9. If you have a terminal emulator program or are using your own software package, this is how the data will appear. The comments appearing after the semicolons are not part of the data stream. Note: The instrument sends data in binary format. You must be sure your data collection program is set to read the binary bit stream. The characters in the table are shown in hexadecimal for clarity. A semicolon denotes a comment and is not seen in the data stream. All two-byte integer words are sent in low byte–high byte order. The three-byte data words are unsigned and sent in low byte, high byte, decimal fraction order.

```

; This is the header section of the packet
00 FF 00 FF ; Packet registration
EE 00 ; Record length of full packet (not including chksum)
00 00 01 05 ; serial number
00 00 ; status (reserved)
00 00 ; filter wheel rotation period
00 00 ; depth (opt)
00 00 ; reserved
; This is the data section of the packet
;Time Ch 1 Ch 2 Ch 3 Ch 4 Ch 5 Ch 6,..., Ch18
0001 B2A1 C4 8123 59 7777 2A 7A3D 20 3B20 10 2345 D0,...,1000 DF
; Time (2 bytes), eighteen groups of three bytes each. Each group represents a
; 24-bit number. Channels are transmitted in the order in which they appear in
; the DEV file.
0001 B2A1 C4 8123 59 7777 2A 7A3D 20 3B20 10 2345 D0,...,1000 DF
;(The above time and data lines are sent a total of 10 times per packet.)
; This is the reference section
; RCh 1 RCh 2 RCh 3 RCh 4 RCh 5 RCh 6,..., RCh18
9919 99 3333 55 2136 40 5211 32 2000 A1 2999 D2 ,...,3333 55
; These are the reference channels.
; Same format as the data fields, which is eighteen groups of three characters
; forming 24-bit numbers. Reference Channels are transmitted
; in the order in which they appear in the DEV file.
0001 ; temperature (2 bytes)
B715 ; checksum
00 00 00 00 00 00 ; padding

```

3.3.2 Primary Processing

When receiving binary packets from an ac-9, the first thing to look for is the packet identifier, which is four characters. The characters, in hex, are 00 FF 00 FF. After successfully receiving these characters, the packet header is the next item to be received.

The packet length includes all bytes sent in the packet, except for the four-byte checksum and the padding bytes. The packet length should be 634 bytes.

The serial number is a standard four-byte long integer. The first two bytes of the serial number denote the instrument type.

The next two bytes are status bytes used for ancillary options.

The floating point scan rate (usually 5.8–6.1 scans per sec) can be calculated from the 2-integer bytes (receivedInt) that are sent with this formula:

$$\text{SampleRate} = (1.0 / (0.00003160 * \text{receivedInt}))$$

The 2-byte status of the meter is currently unused.

To calculate the depth from the two integer depth bytes, this formula is used:

$$D = mD_{raw} + b$$

where:

D = depth in meters

D_{raw} = raw number of counts sent by the device

m = multiplier determined in the laboratory for each depth sensor unit and is unique to that unit; stored in the configuration file

b = offset determined by calibrating the device at sea level (this can easily be done in the field); stored in the configuration file

As stated above, the signal data is sent as eighteen groups of three characters. Each group of three characters represents a 24-bit number. This number is the actual signal measurement for a particular wavelength. The order of this data is the nine **a** channels, and then the nine **c** channels. The order of the wavelengths within the **a** and **c** channels is contained in the device file included with a particular meter. To convert the three characters that are received for each channel to a floating-point number, use this formula:

$$csig = ((double)(char1 + [char2*256]) + (char3 / 256.0))$$

Each group of signal data is preceded by a two-byte time. This is an integer in milliseconds. Time starts at zero when the meter is powered on.

The time and data groups, with 56 characters per group, are repeated 10 times each packet. After the time and data groups are sent, a reference packet is sent. This reference packet contains reference signal values for each wavelength in the **a** and **c** channels. The reference packet uses the same format as the data packet in that nine groups of three characters are sent for **a** and **c**. This means a total of 54 characters are sent for reference information. The 3-byte, 24-bit reference word is converted to a floating-point value by using this formula:

$$cres = ((double)(char1 + [char2*256]) + (char3 / 256.0))$$

After the reference is sent, a two-byte temperature word is sent.

The temperature is given as a reading from a thermistor. The manufacturer of the thermistor provides a table correlating the reading (counts) to temperature. That table fits the polynomial equation given above. Using 271 counts, we get:

$$\begin{aligned} &10.61831 \\ &+ 0.045113 * 271 \\ &+ -4891.32 * 1/271 \\ &+ 208130.2 * 1/271^2 \\ &+ 1171473 * 1/271^3 = 7.69 \text{ degrees C} \end{aligned}$$

At the end of the entire packet, a four-byte checksum is sent. This checksum is the sum of all characters sent in the packet, including the identifier (FF 00 FF 00).

Several padding characters are sent at the end of the packet before the next packet identifier is sent.

3.3.3 Post Processing

Once accumulated by a host computer the data must be post processed to yield meaningful scientific data.

The primary transfer equation for yielding the attenuation coefficient, **c** or the absorption coefficient, **a** for a given wavelength is:

$$Tr = e^{-cx} \quad (1)$$

where Tr is the transmittance, c is the attenuation coefficient, and x is the pathlength of the water volume being measured. The following treatment applies to the absorption case if **c** is replaced by **a**. The pathlength of the ac-9 is fixed at either 25 or 10 cm. In the case of the ac-9 the transmittance is computed by taking the ratio of the signal value to the reference value:

$$Tr = (C_{sig}/C_{ref}) / N \quad (2)$$

Substituting equation (2) into equation (1) we get,

$$(C_{sig}/C_{ref}) / N = e^{-cx}, \quad (3)$$

where C_{sig} and C_{ref} are the signal and reference count values from the instrument and N is an instrument specific calibration constant obtained in the laboratory using clean water. For more information about how N is derived, see Section 4, Calibration and Characterization.

We therefore can solve for **c** (or **a**) by,

$$c = -1/x [\ln(C_{sig}/C_{ref}) - \ln(N)] \quad (4)$$

$$\text{or } c = -1/x (\ln(C_{sig}/C_{ref})) - (-1/x (\ln(N))) \quad (5)$$

$$\text{or } c = [(\ln(N)/x) - (\ln(C_{sig}/C_{ref})/x)] \quad (6)$$

Since the ac-9 pathlength is a fixed constant set at either 10 or 25 cm, we only require the determination of $(\ln(N)/x)$ in order to accurately measure **c**. This value is derived for each channel and is supplied with each instrument's calibration data sheet as the "Water Offset" value and is referred to as c_{off} in equation (7).

The temperature correction is applied using the temperature from the reference line and the channels correction table from the configuration file. The approximate correction value is linearly interpolated from the table. First, the correct temperature bin is determined by finding the two bin temperatures, T_0 and T_1 , that bracket the current temperature. Then, using the values, Δ_{T_n} and $\Delta_{T_{n+1}}$, from the table, we obtain

$$\Delta_T = \Delta_{T_n} + \frac{(T - T_0)}{(T_1 - T_0)} * (\Delta_{T_{n+1}} - \Delta_{T_n}) \quad (7)$$

where,

Δ_T = compensation constant

T = current temperature

T_0 = first bin temperature

T_1 = second bin temperature

Δ_{T_n} = first value

$\Delta_{T_{n+1}}$ = second value

This temperature correction is automatically applied by our WETView software. If you are manually processing the raw data stream, this correction must be applied to arrive at the temperature-corrected absorption and attenuation coefficients.

3.3.4 Temperature-dependent Absorption Correction

Absorption of water shows a temperature dependency that is wavelength-dependent. While throughout the visible portion of the spectrum this effect is negligible (See Pegau and Zaneveld, 1992, 1994), at infrared wavelengths the effect must be taken into account. With regard to the ac-9 the water absorption temperature effect must be considered to correct the absorption and attenuation at 715 nm.

Experimental results show that a_{T^*} , the water-specific absorption correction due to temperature at 715 nm is approximately 0.0035 per m-deg. Various researchers (Pegau, Moore) have derived results ranging from 0.0024 to 0.0035. The corrected 715 nm absorption is then determined using

$$a_{715T} = a_{715m} - [a_{T^*} * (T_m - T_{cal})] \quad (8)$$

where a_{715T} is the water temperature corrected absorption at 715 nm, a_{715m} is the measured absorption at 715 nm, T_m is the water temperature at the time of measurement and T_{cal} is the water temperature at time of calibration. T_{cal} is recorded at the time of calibration and is provided with the instrument calibration sheet.

Note

WETView does not perform this water-based absorption temperature correction.

3.3.5 Scattering Correction

As described in the Instrument Description section of this manual, the absorption meter uses a reflective tube to collect scattered light. Because of the reflective tube and detector design, some of the light scattered at wider angles than 41.7 degrees with respect to the optical axis is lost. This results in a scattering error for the absorption meter. This error was empirically determined by measuring apparent **a** and **c** values in the presence of increasing concentrations of a scattering agent (Maalox). The error in all channels was between 18 and 19 percent throughout most of the **a**-meter's dynamic range. The relationship between **a** and **c** remains linear throughout most of a given wavelength channel's dynamic range. (>.998) For very high **c** values (>12 m⁻¹) we noticed a slight roll-off in **a**.

The imperfect reflectivity of the reflecting tube and other imperfections cause scattered light errors in the absorption meter. The magnitude of these errors must be corrected to obtain accurate absorption values. There are several alternatives in performing the scattered light correction. The simplest involves subtracting the temperature-corrected a_{715} measurement. Assuming that water is the only species present that absorbs light at 715 nm, and assuming that the scattering error is spectrally independent, we can use this wavelength to provide a base for the scattering error correction. This technique is commonly used in bench-top spectrophotometric measurements. We present one recommended method developed by Dr. Ron Zaneveld at Oregon State University (SPIE 1992) that has thus far proven to be a robust correction mechanism.

For what follows we assume that pure water absorption and attenuation have been subtracted.

For a given wavelength (λ) the absorption tube overestimates the absorption coefficient as it does not measure all of the scattered light. In what follows we will designate the proportion of the total scattering coefficient that the device does not receive by $k_a(\lambda)$.

If the shape of the scattering function does not change much as a function of wavelength, we may assume that $k_a(\lambda)$ is not a function of λ .

3.3.5.1 Hypothesis 1

The fraction of scattered light not received by the absorption meter is independent of wavelength.

We designate the *true* absorption coefficient at a wavelength by $a_t(\lambda)$. The true absorption coefficient at a given wavelength is the sum of the absorption due to pure water, $a_w(\lambda)$, and the absorption due to dissolved and suspended matter, $a_n(\lambda)$ (n for non-water), so that

$$a_t(\lambda) = a_w(\lambda) + a_n(\lambda). \quad (1a)$$

The measured absorption coefficient is designated by $a_m(\lambda)$. The measured absorption coefficient consists of the sum of the absorption due to pure water, $a_w(\lambda)$, and the instrument output, $a_i(\lambda)$, so that

$$a_m(\lambda) = a_w(\lambda) + a_i(\lambda). \quad (1b)$$

Similarly, $c_t(\lambda)$ and $c_m(\lambda)$ are the true and measured attenuation coefficients, respectively. We define the scattering coefficients similarly:

$$b_t(\lambda) = c_t(\lambda) - a_t(\lambda) \quad (2a)$$

$$b_m(\lambda) = c_m(\lambda) - a_m(\lambda) \quad (2b)$$

$$b_i(\lambda) = c_i(\lambda) - a_i(\lambda) \quad (2c)$$

$$b_m(\lambda) = b_w(\lambda) + b_i(\lambda) \quad (2d)$$

Using Hypothesis 1, we then set:

$$a_t(\lambda) = a_m(\lambda) - k_a b_t(\lambda), \quad (3)$$

and
$$c_t(\lambda) = c_m(\lambda) + k_c b_t(\lambda). \quad (4)$$

We have assumed here that the scattered light received by the attenuation meter is also independent of wavelength, so that it is a constant proportion of the total scattering coefficient.

3.3.5.2 Hypothesis 2

The fraction of scattered light received by the attenuation meter is independent of wavelength.

We now subtract equation (3) from (4):

$$b_t(\lambda) = b_m(\lambda) + b_t(\lambda)[k_c + k_a], \quad (5)$$

so that:

$$b_t(\lambda) = b_m(\lambda) / (1 - k_c - k_a) \quad (6)$$

Since, using hypothesis 1 and 2, k_c and k_a are constants, we see that the measured scattering coefficient spectrum, $b_m(\lambda)$, is only a constant $[1/(1 - k_c - k_a)]$ different from the true scattering spectrum. We may conclude that:

$$b_t(\lambda_1) / b_t(\lambda_2) = b_m(\lambda_1) / b_m(\lambda_2) \quad (7)$$

We now assume there are some reference wavelengths, λ_r , at which the absorption is due to pure water only.

3.3.5.3 Hypothesis 3

There exists a reference wavelength, λ_r , at which the absorption due to particulate and dissolved material is negligible.

For the present we set $\lambda_r = 715$ nm, although there may be better choices further in the infrared.

Thus,
$$a_t(\lambda_r) = a_w(\lambda_r) \quad (8)$$

Substitution of equation (8) into (3) gives:

$$a_w(\lambda_r) = a_m(\lambda_r) - k_a b_t(\lambda_r),$$

so that, using equation (1b),

$$0 = a_i(\lambda_r) - k_a b_t(\lambda_r).$$

Rearranging gives

$$a_i(\lambda_r) = k_a b_t(\lambda_r). \quad (9)$$

Hence,

$$k_a = a_i(\lambda_r)/b_t(\lambda_r). \quad (10)$$

Substitution of equation (10) into (3) gives:

$$a_t(\lambda) = a_m(\lambda) - a_i(\lambda_r)[b_t(\lambda)/b_t(\lambda_r)] \quad (11)$$

Substitution of equation (7) into the above gives:

$$a_t(\lambda) = a_m(\lambda) - a_i(\lambda_r)[b_m(\lambda)/b_m(\lambda_r)].$$

After subtraction of the water absorption from both sides we get the desired result:

$$a_n(\lambda) = a_i(\lambda) - a_i(\lambda_r)[b_m(\lambda)/b_m(\lambda_r)]. \quad (12a)$$

Referring back to equation (2d) we note that in the vast majority of natural waters

$$b_m(\lambda) \gg b_w(\lambda),$$

so that in those cases equation (12a) may be approximated by:

$$a_n(\lambda) = a_i(\lambda) - a_i(\lambda_r)[b_i(\lambda)/b_i(\lambda_r)]. \quad (12b)$$

This is the desired result that allows us to correct the scattering error of the absorption measurement. Note that we can thus determine the true non-water absorption coefficient at any wavelength using the three hypotheses. We do not need to know the fraction of scattered light not received by the attenuation meter, i.e. we need not know k_c .

For spectrophotometric work one normally cannot take into account the spectral variations in $b(\lambda)$. One simply subtracts the absorption at the reference wavelength. This then would imply that $b_m(\lambda_r) = b_m(\lambda)$ from equation (12), an unnecessary assumption in our case. The above correction method is thus more accurate than the usual spectrophotometric approach. We only assume that the shape of the volume scattering function be independent of wavelength, whereas in the spectrophotometric approach it is assumed that the absolute value of the scattering function be independent of wavelength.

The accuracy of the absorption meter may be expressed in terms of k_a . From the above, we can derive an expression for k_a .

Substitution of (6) into (9) gives:

$$a_i(715) = [k_a / (1 - k_c - k_a)] b_m(\lambda_r), \quad (13)$$

solving for k_a then gives,

$$k_a [a_i(\lambda_r) + b_m(\lambda_r)] = (1 - k_c) a_i(\lambda_r).$$

The scattering coefficient of pure water at the reference wavelength is very small, so that $a_i(\lambda_r) + b_m(\lambda_r) \approx c_i(\lambda_r)$ and,

$$k_a = (1 - k_c) [a_i(\lambda_r) / c_i(\lambda_r)]. \quad (14)$$

We can use equation (14) to determine the error in an absorption meter, provided hypotheses 1, 2, and 3 are true.

k_c is the scattered light included in the attenuation measurement. This depends, in a collimated system, on the acceptance angle of the detector. We should know this parameter to within 10 percent of the scattering coefficient. The remaining error is then determined by $a_m(\lambda_r) / c_m(\lambda_r)$.

In a recent ac-9 test, $a_i(715) / c_i(715)$ was 0.33. k_c was guessed to be 0.12 (+/- 0.05). We would then set

$$k_a = (0.03) (0.88 \pm 0.05),$$

and $k_a = 0.29 \pm 0.017$.

This implies that the absorption meter did not receive 29 percent of the scattered light and that we can correct for this effect to within 1.7 percent of the scattering coefficient.

4. Calibration and Characterization

One can think of the ac-9 as a single beam spectrophotometer whose output values are related to a specific reference medium that is clean water. The instrument is calibrated to provide a reading of 0.00 for each channel in clean fresh water. The offset value, determined during our calibration process, is the number which, when added to the raw instrument output in clean water, provides zeroes for all wavelengths with the meter at a specific temperature. This offset value is referred to as **N** in the preceding sections. This is an important consideration for users who want to compare data from other transmissometers that do not read 0.0 in clean water. Therefore, the final output of the ac-9's software is the absorption and attenuation with clean water attenuation subtracted out. To get absolute or true absorption, the post-processing steps discussed in Section 3.3.3 should be applied.

4.1 Temperature Correction

Beyond confirming basic instrument operation and alignment, temperature corrections are the first tests performed on the meter. Temperature corrections are requisite to all other tests. Corrections are performed using WETView. WETView employs a correction algorithm that uses multiple offset values, Δ_{T_n} values obtained by measuring output differences over small temperature increments. Instrument values are collected and averaged every one to two degrees Celsius through the operational temperature range of the instrument. From these values we generate a table of temperature compensation offsets [Δ_{T_n}]. This table is contained in each instrument's device file. Using the table, WETView 5.0 then applies the algorithm [$a' = a_{raw} - \Delta_{T_n}$] for given temperatures in the table. For temperatures that fall between table values, the program applies a linear interpolation upon the data for further correction. By using this scheme, we can thus effectively compensate for non-linear changes due to temperature in the instruments' output. For a description of this algorithm please refer to section 3.3.3, Post Processing.

4.2 Precision

Precision is determined by running the meter for an interval of time and determining the standard deviation of the signal. We perform this measurement in air. With one-second binning of the signals, nominal performance is approximately 0.001/m for a 25 cm path instrument. Since the absorption or attenuation measurement is pathlength-dependent, precision values increase approximately by a factor of 2.5 for the 10 cm pathlength version of the ac-9.

It should be noted that both air value and water value measurements can be difficult to perform. If running the tests in air, you must insure that the flow tubes and windows are completely clean and dry. Do not allow any ambient light penetration into the cells. Use a cap or black tape to seal the flow tube nozzle openings.

When operating the instrument in water, use clean water, free of bubbles, and do not exceed flow rates of 1–2 liters per minute.

4.3 Absolute Calibration

Absolute calibration of any underwater optical absorption or attenuation sensor is difficult as there are no absolute standards that can readily be used. The most obvious choice for a calibration medium, pure water, is difficult to obtain, is unstable once it is made, and its absolute optical properties are not well known. Nevertheless, pure water is the baseline for all oceanic property measurements. At WET Labs, we produce our calibration water with a custom de-ionization and filtration system. After de-ionization, the water is processed by a series of filters and held in a 60-liter reservoir that re-circulates through an ultra-violet chamber and additional filters. Water for calibration is drawn through a final 0.01-micron ultrafilter before being used. This system allows the highly reactive de-ionized water to equilibrate, and the ultra-violet chamber prevents any biological contamination from entering the reservoir.

A qualitative but surprisingly accurate test of water purity can readily be obtained using a beaker and a small laser in a darkened room. By shining the laser through the water and viewing slightly off axis to the impinging beam, one can readily detect scatterers in the water. Try this first with some tap water. It will show you what to look for. Be very careful to not look directly into the beam, and **do not** try this test with a high power laser. The pointing lasers used in lectures work very well for this task. If you see more than one or two large scatterers in the beam path, your water is unsuitable for a clean water calibration. WET Labs and researchers from several institutions are presently developing methods for effective field calibration and in-situ calibration techniques. We provide tech notes on these methods as they are developed and validated.

4.4 Linearity and Dynamic Range

To determine linearity of the absorption and attenuation detection systems we first vary scattering agent concentrations and plot apparent **a** and **c**. Typically, linearity in **c** throughout the dynamic range is extremely high with a regression coefficient of 0.9999. Linearity in **a** exceeds 0.998. Although this test doesn't truly measure **a** it does give a good indication of response. We have also tested linearity in **a** using an orange food coloring. Linearity in the blue channels was on the order of 0.999. The red channels showed very little change due to the food coloring. If you try this test in the lab, use a dye not likely to permanently stain the receiver. A Japanese researcher has reported good results using Japanese green tea.

The scattering tests and dye tests also enable us to determine the instrument's dynamic range. We determine dynamic range by dividing the response range for a given channel that exceeds a regression coefficient of 0.998. This relatively conservative criterion provides a worst-case dynamic range of about 16,000 to 20,000 in a_{412} . The dynamic range of all other absorption channels exceeds 20,000. The worst-case **c** dynamic range is typically c_{412} , which is about 50,000. That of the other **c** channels exceeds 100,000.

4.5 Air Calibration and Tracking

During the factory calibration, clean water values are obtained and used to correct the meter's output. We then thoroughly dry the meter and record air values. We supply these values with the calibration page shipped with each meter. These air values represent the effective measurement of air for a calibrated instrument. This means that if the instrument

user cleans the windows and flow tubes and makes an air measurement and that if the air measurement matches the factory supplied air values, then resulting clean water measurements should provide zero values. Equally important—if the air values taken in the field differ from factory air values, then that difference may be applied as a correction factor to the original water calibration values contained in the DEV file:

$$\mathbf{a}'_{\text{clean}} = \mathbf{a}_{\text{clean}} + (\mathbf{a}'_{\text{air}} - \mathbf{a}_{\text{air}}) \quad (1)$$

where:

- $\mathbf{a}_{\text{clean}}$ is the clean water offset value supplied with the ac meter
- $\mathbf{a}'_{\text{clean}}$ is the corrected clean water offset
- \mathbf{a}_{air} is the factory supplied air value
- \mathbf{a}'_{air} is the field obtained air values

Alternatively, the offset air value difference can be applied directly to the data as a post-processing step. Obtaining air values in the field is a much more straightforward process than obtaining clean water values. This is a powerful technique that can track and compensate for instrument drift and filter aging. Care must be taken when implementing this technique since a drop of water or smudge on the windows will result in a reading quite different from the factory air values. This difference might be interpreted as instrument drift. By iterating this process several times (re-cleaning the instrument and obtaining a new set of air values), you will gain experience in differentiating true instrument drift from smudged optics.

Caution

Back up the factory DEV file before making any modifications to it.

Effective air calibration requires:

- 1. The instrument's optical path is clean and dry.**
- 2. The instrument's optical path is completely shielded from ambient light.**

To perform air tracking we recommend the following basic procedures.

- a.** Remove flow tubes and clean and dry completely. Remove the sleeves from the flow tubes to assure there is no trapped moisture. Allow the flow tubes to sit in a dry environment with good air flow.
- b.** Clean and completely dry the optical windows of the instrument. If the optics have not been cleaned for some time, clean with a mild solution of detergent and distilled water, rinse, and wipe dry. Follow with a single wipe across each window with an ethanol-soaked lens tissue (or other low water content alcohol-type solvent) and then a single wipe with a dry tissue. If the windows are already fairly clean, simply use the ethanol wipe procedure. You may wish to apply a stream of pressurized air or nitrogen around the windows to force moisture from the window mount.

WARNING

Beware of using standard air compressor air. It can blow oil all over the optics.

- c.** Allow the unit to sit open for an hour or two to assure that it dries.

- d.** Turn on meter and allow it to warm up about 15 minutes.
- e.** Reassemble and insert flow tubes.
- f.** Block ambient light from the flow tube entrances and obtain values using WET View or your own custom program. Record and save about 5 minutes worth of data. Examine your data in a spreadsheet. At one second binning (6 samples) the data should maintain a standard deviation of 0.001 m^{-1} or less. If you have a substantial slope to the data over the acquisition period your meter may have some residual moisture in the flow tubes or on the windows. If the optical path isn't getting dry, use a small flow of dry nitrogen through the tubes while sampling.
- g.** Remove flow tube and re-clean the windows. The single wipe technique with ethanol will work fine at this point.
- h.** Repeat steps D–F until mean values stabilize over three cycles. Use these values as air calibration values.

5. Specifications

Mechanical

Size	27.1 x 4.1 in diameter (69 x 10.4 cm diameter)
Weight	in air: 13 lbs (5.9 kg) acetal copolymer; 16 lbs (8 kg) aluminum in water: 2.5 lbs (1.1 kg) acetal copolymer; 7 lbs (3.2 kg) aluminum
Rated Depth	500 or 5,000 meters

Electrical

Input	10–18 VDC
Power Requirement	9 watts @ 12 VDC
Output	RS-232/RS-485
Precision	+/- 0.003 m ⁻¹ @ 6 Hz scan rate +/- 0.001 m ⁻¹ @ 1 Hz scan rate
Accuracy	+/- 0.01 m ⁻¹
Dynamic Range	10 ⁴ (attenuation); 20 ³ (absorption)
Linearity Error	< 0.2 percent
Sample Rate	6 scans/sec, nominal
Temperature	0–30 deg C

Optical

Spectral Range	410 nm–715 nm
Bandpass	10 nm/channel
Pathlength	25 cm (10 cm optional)
Beam cross-section	8 mm diameter, nominal

5.1 Connectors

The ac-9 has two bulkhead connectors mounted on the top flange. The power and data connector has six pins and connects to the sea or test cable. It provides input power to the instrument and data output in RS-232 and RS-485 formats. A second connector with three sockets provides power to the pump (Figure 8). Pin or socket numbers are molded into the rubber bodies of the plugs (Figures 9 and 10).

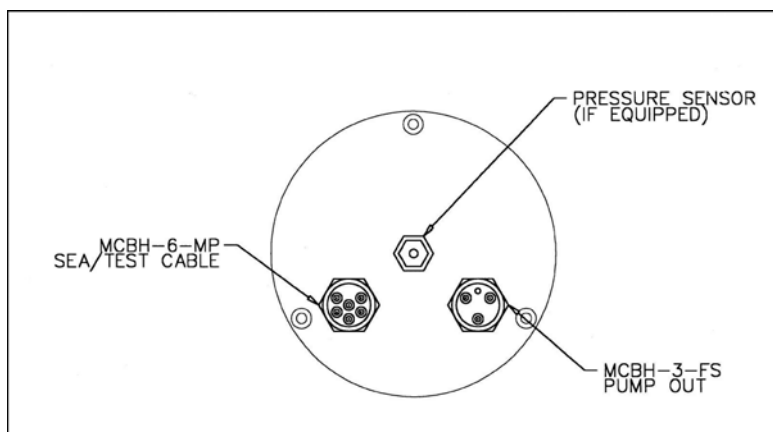

Figure 8. Top Flange Connectors

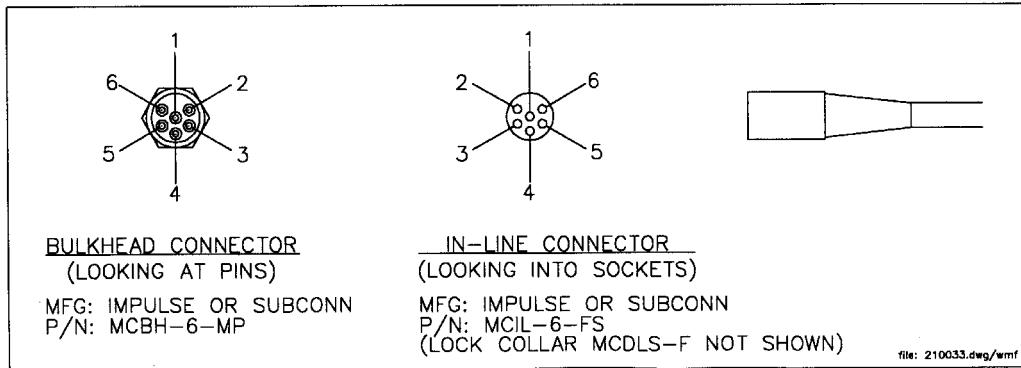

Figure 9. Sea/Test Cable Connector Pin and Socket Arrangements

Sea/Test Cable Connector Pin or Socket Function	
1	Common
2	RS-232 Receive
3	RS-485 +
4	Voltage in +10 to +18 VDC
5	RS-232 Send to Host
6	RS 485 -

Voltage supplied to the instrument is internally jumpered to provide power output to the pump port connector. Power is applied to the pump connector whenever the meter is powered.

WARNING

If the meter is deployed without a plug in the pump connector socket, the socket contacts will suffer rapid corrosion. Eventually, the corrosion could travel through the connector, causing the meter to flood.

Always put a pump plug or dummy plug in this socket!

Pin and socket assignments for the pump power connector are shown below.

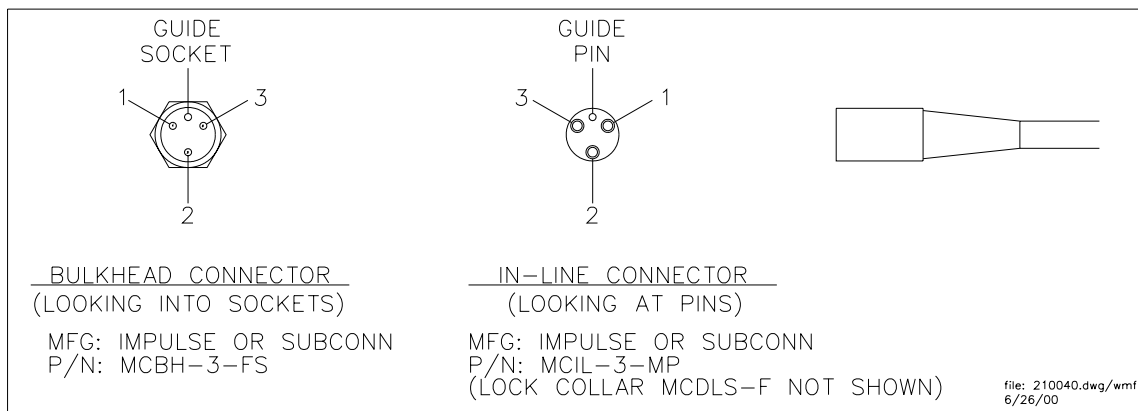

Figure 10. Pump Cable Connector Pin and Socket Assignments

Pump Power Cable Connector Pin or Socket Function	
1	Common
2	Power Output (10–18 VDC)
3	N/C

5.2 Power Requirements

Voltage Input:	10–18 VDC
Power Requirements:	(may differ by +/- 10 percent)
Lamp 1	2.5 Watts
Lamp 2	2.5 Watts
CPU board	2.0 Watts
Other Electronics	0.5 Watts
<u>DC-DC Converter</u>	<u>1.5 Watts</u>
TOTAL	9.0 Watts

6. References

The following references have been cited in this manual:

Moore, C., In-situ, biochemical, oceanic, optical meters, *Sea Technology*, Vol 35, No. 2, 10–16, 1994.

Zaneveld, J.R.V., J.C. Kitchen, A. Bricaud, C.C. Moore, Analysis of in-situ spectral absorption meter data, *Ocean Optics XI, Proc. Soc. Photo-Optical Instrum. Eng. (SPIE)*, Vol. 1750, 1992.

Moore, C., J.R.V. Zaneveld, J.C. Kitchen. Preliminary results from an in-situ spectral absorption meter, *Ocean Optics XI, Proc. Soc. Photo-Optical Instrum. Eng. (SPIE)*, Vol. 1750, 330–337, 1992.

Pegau, W.S., J.R.V. Zaneveld, Temperature dependence of the absorption coefficient of pure water in the visible portion of the spectrum, *Ocean Optics XII, Proc. Soc. Photo-Optical Instrum. Eng. (SPIE)*, Vol. 2258, 597–604, 1994.

Roesler, C. S., J.R.V. Zaneveld, High resolution vertical profiles of spectral absorption, attenuation and scattering coefficients in highly stratified waters, *Ocean Optics XII, Proc. Soc. Photo-Optical Instrum. Eng. (SPIE)*, Vol. 2258, 309–319, 1994.

Zaneveld, J.R.V., J. C. Kitchen and C. C. Moore, Scattering error correction of reflecting tube absorption meter, *Ocean Optics XII, Proc. Soc. Photo-Optical Instrum. Eng. (SPIE)*, Vol. 2258, 44–55, 1994.

Appendix A: Optional Connectors

The ac-9 is also available with a VSK-6-BCL bulkhead connector. The pin and socket arrangements are shown below in Figure A.1. Note that the pin and socket arrangements differ from the standard configuration (see Section 5.1), though the pin and socket functions are the same for either connector.

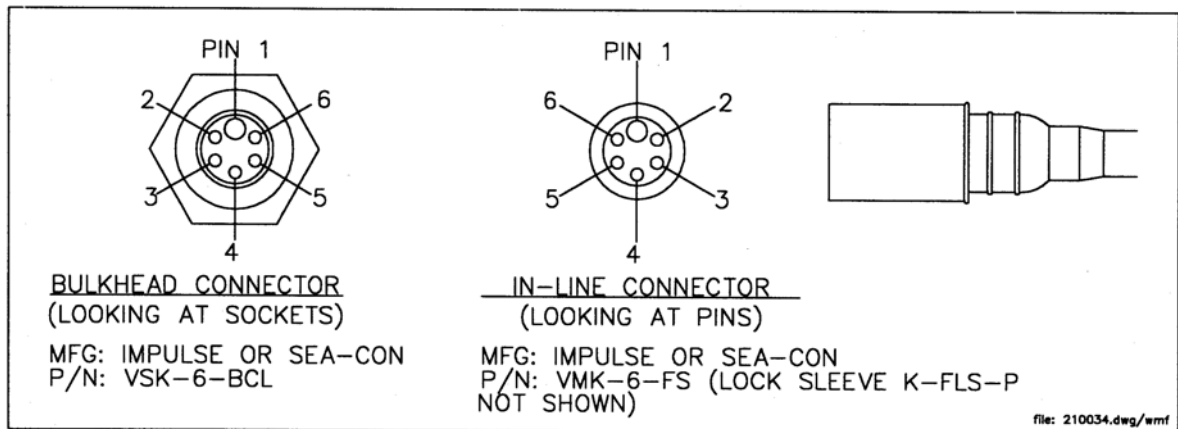

Figure A.1 Optional VSK-6-BCL Bulkhead Connector Pin and Socket Arrangements

Sea/Test Cable Connector Pin or Socket Function	
1	Common
2	RS-232 Receive
3	RS-485 +
4	Voltage in +10 to +18 VDC
5	RS-232 Send to Host
6	RS 485 -

Waterproof patch cables to adapt one connector style to the other are available from WET Labs. Figure A.2 shows the patch cable to connect an instrument with the newer connector to an older sea cable. Figure A.3 show the patch cable to connect an instrument with an older connector to a newer sea cable.

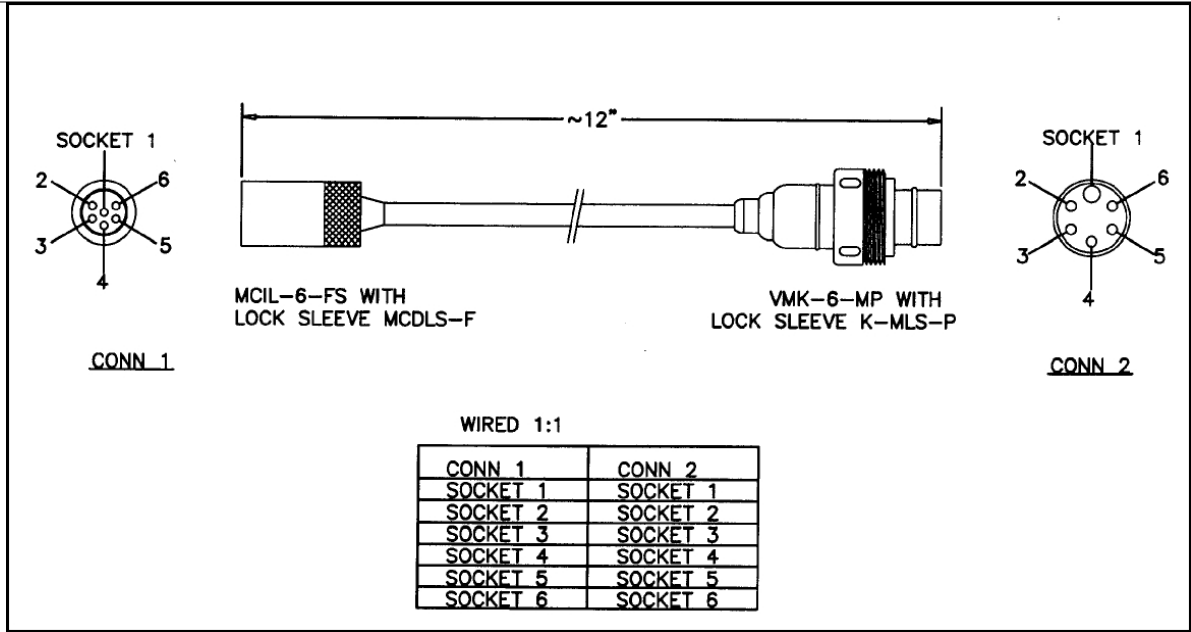

Figure A.2 Newer Instrument Connector-to-Older Sea Cable (WET Labs dwg. 210051)

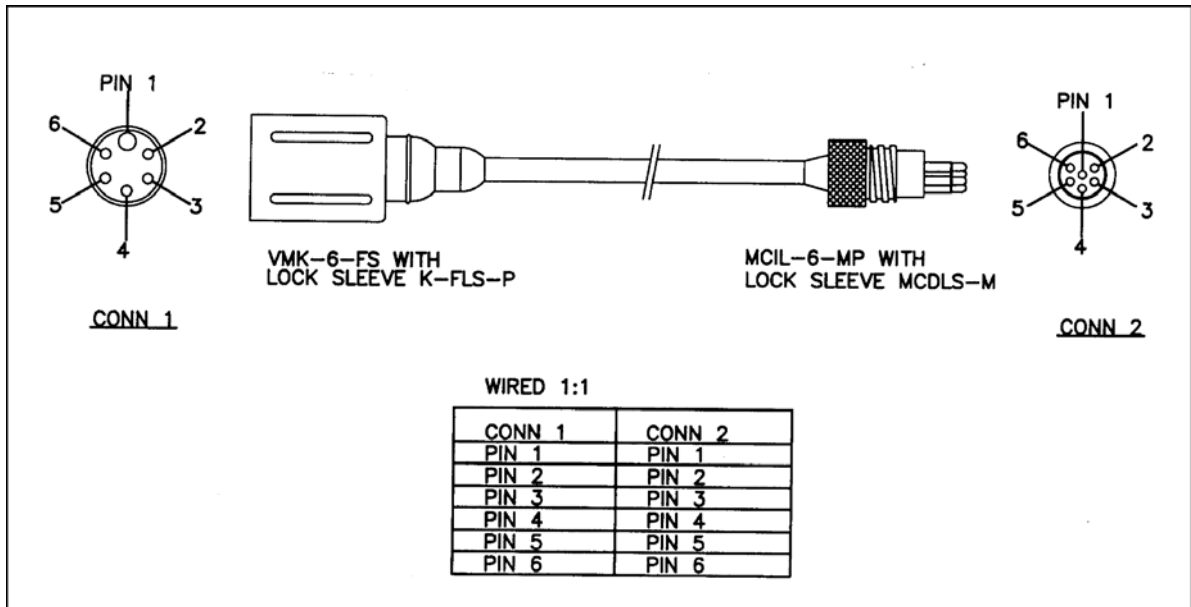

Figure A.3 Older Instrument Connector-to-Newer Sea Cable (WET Labs dwg. 210052)

Appendix B: Pressure Sensor Use and Care

A pressure sensor is available as optional equipment on the ac-9. It is mounted in the top flange next to the electrical connectors. A plastic fitting and capillary tube, both filled with silicone oil, provide a buffer between the pressure transducer and seawater. The transducer is both sensitive and delicate. Following the procedures below will ensure the best results and longest life from your pressure sensor.

Pressure is transmitted from the water to the stainless steel transducer diaphragm via a capillary tube filled with silicone oil. The inert silicone oil protects the pressure sensor from corrosion, which would occur after long exposure to salt water. The capillary tube will generally prevent the oil from escaping from the reservoir into the water. However, you may occasionally wish to ensure that oil remains in the reservoir on top of the transducer.

WARNING

Never touch or push on the transducer.

WARNING

Never attempt to fill the reservoir except by the procedure below.

Refilling procedure

1. Thoroughly clean the top of your instrument.
2. Completely remove the white nylon Swagelock fitting using a 9/16" wrench.
3. Add silicone oil (Dow Corning DC200, supplied) to within 1/16" of the top of the threaded cavity.
4. Wipe clean the o-ring at the base of the Swagelock fitting.
5. Hold a tissue over the end of the capillary tube.
6. Screw the Swagelock fitting into the end flange until finger tight.
7. Tighten it an additional 1/8 turn using a wrench only if necessary.
8. Wipe up any excess oil that may have squirted out of the capillary tube.

Hints

- If you can see drops of oil in the capillary tube, refilling is unnecessary.
- Rinsing the instrument with fresh water will help keep the tube end open.

Revision History

Revision	Date	Revision Description	Originator
A	10/07/99	Begin revision tracking	H. Van Zee
B	01/11/00	Update document (DCR 4)	D. Hankins
C	01/17/00	Clarify packet information (DCR 13)	D. Romanko
D	02/17/00	Change bulkhead connector and pin information (DCR 14)	A. Derr
E	04/18/00	Add drawing showing top flange bulkhead connector for pump (DCR 25/ECN 113)	A. Derr
F	06/12/00	Change pump connector functions in table (DCR 36)	A. Derr
G	06/26/00	Correct pump connector wiring (DCR 42), (ECN113R2)	A. Derr
H	07/11/00	Correct temperature correction equation (DCR 46)	C. de Lespinasse
I	07/27/00	Add Appendix B, Pressure Sensor (optional) Use and Care (DCR 49)	H. Van Zee
J	10/09/00	Add reference to deep unit (DCR 62)	H. Van Zee
K	8/13/01	Renummer graphics, reorganize sections 3–6 (DCR 135)	H. Van Zee
L	1/10/03	Review and update Section 1; correct depth rating (DCR 265)	D. Stahlke, H. Van Zee