

ECO 3-Measurement Sensor (Triplet)

User's Guide

The user's guide is an evolving document. If you find sections that are unclear, or missing information, please let us know. Check our website periodically for updates.

WET Labs, Inc.
PO Box 518
Philomath, OR 97370
(541) 929-5650
fax: (541) 929-5277
www.wetlabs.com



ECO Sensor Warranty

This unit is guaranteed against defects in materials and workmanship for one year from the original date of purchase. Warranty is void if the factory determines the unit was subjected to abuse or neglect beyond the normal wear and tear of field deployment, or in the event the pressure housing has been opened by the customer.

To return the instrument, contact WET Labs for a Return Merchandise Authorization (RMA) and ship in the original container. WET Labs is not responsible for damage to instruments during the return shipment to the factory. WET Labs will supply all replacement parts and labor and pay for return via 3rd day air shipping in honoring this warranty.

Return Policy for Instruments with Anti-fouling Treatment

WET Labs cannot accept instruments for servicing or repair that are treated with anti-fouling compound(s). This includes but is not limited to tri-butyl tin (TBT), marine anti-fouling paint, ablative coatings, etc.

Please ensure any anti-fouling treatment has been removed prior to returning instruments to WET Labs for service or repair.

Shipping Requirements

1. Please retain the original Pelican® shipping case. It meets stringent shipping and insurance requirements, and protects your meter.
 2. Service and repair work cannot be guaranteed unless the meter is shipped in its original case.
 3. Clearly mark the RMA number on the outside of your case and on all packing lists.
 4. Return instruments using 3rd day air shipping or better: do not ship via ground.
-

Table of Contents

1. Overview	1
1.1 Connectors	1
1.2 Optional Equipment	2
1.3 Delivered Items	4
2. Specifications	5
3. Instrument Operation	5
3.1 Initial Checkout	6
3.2 Operating the Sensor for Data Output	6
3.3 Deployment	8
3.4 Upkeep and Maintenance	8
4. Triplet-B: Using Internal Batteries	9
4.1 Removing End Flange and Batteries	9
4.2 Replacing End Flange and Batteries	10
4.3 Checking Vent Plug	11
5. Data Analysis	12
5.1 Scattering Data Corrections	12
5.2 Derived Parameters	13
6. Calibration/Characterization and Testing	15
6.1 Scattering Calibration	15
6.2 Fluorometer Characterization	16
6.3 Testing	16
7. Terminal Communications	17
7.1 Interface Specifications	17
7.2 Command List	17
8. Device and Output Files	18
8.1 Plot Header	18
8.2 Column Count Specification	18
8.3 Column Description	18
8.4 Output and Device File Formats	19
Appendix A: Mounting Bracket Drawing	21

1. Overview

WET Labs offers the custom *ECO* Triplet as a three-sensor instrument that can be configured for a variety of measurements:

- Three scattering
- Three fluorescence
- Two scattering, one fluorescence
- Two fluorescence, one scattering

Available measurement options:

- | Scattering | Fluorescence |
|--|---|
| <ul style="list-style-type: none"> • Blue • Green • Red | <ul style="list-style-type: none"> • Chlorophyll • CDOM (limited to one CDOM channel) • Uranine (fluorescein) • Phycoerythrin, phycocyanin • Rhodamine |

The Triplet has digital output, logging capability, and is fully configurable. It is also available with internal batteries.

1.1 Connectors

The *ECO* Triplet uses a six-pin bulkhead connector; the pin functions are shown below.

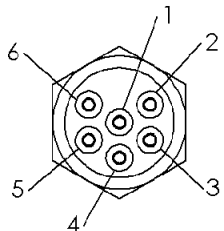
Pin	Function	
1	Ground	
2	RS-232 (RX)	
3	Reserved	
4	V in	
5	RS-232 (TX)	
6	Reserved	

WARNING

If you are going to build or use a non-WET Labs-built cable, do not use the wire from pin 3 or the *ECO* meter will be damaged.

Input power of 7–15 VDC is applied to pin 4. The power supply current returns through the common ground pin. The input power signal has a bi-directional filter. This prevents external power supply noise from entering into *ECO* Triplet, and also prevents internally generated noise from coupling out on to the external power supply wire. Data is sent out the serial output pin.

1.1.1 Connectors for Units with Internal Batteries

Units equipped with internal batteries have a second bulkhead connector that comes with a power plug to supply power to the unit. The pin functions for this connector are shown in Figure 2. Table 2 summarizes pin functions for the 3-socket bulkhead connector.

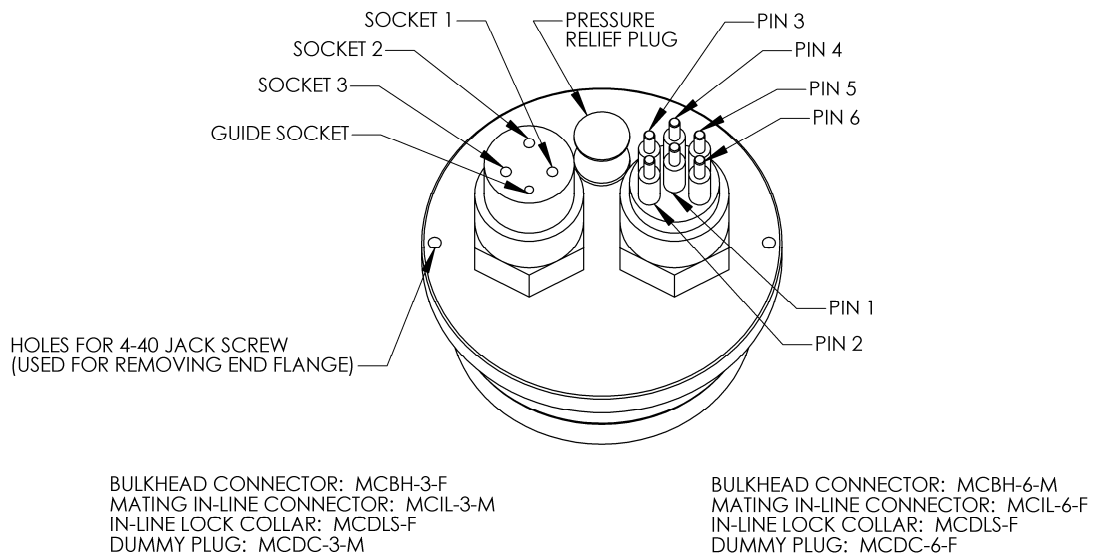

Figure 1. *ECO* connector schematic, internal battery units

Table 2. Pinout summary for *ECO* 3-socket connector

Pin (or Socket)	Function
1	V in
2	N/C
3	Battery out

1.2 Optional Equipment

Triplet meters are available with the following optional equipment:

- test cable
- internal batteries
- thermistor
- pressure sensor

1.2.1 Test Cable

A test cable is optionally available with each unit. This cable includes three legs:

1. A connector for providing power to the instrument from a user-supplied 9V battery.
2. A DB-9 serial interface connector.
3. A six-socket in-line connector for providing power and signal to the instrument.

1.2.2 Batteries

ECO units with internal batteries are supplied with six 9-volt Lithium batteries as their power source. They can use either standard alkaline cells for a total capacity of approximately 1000 mA-hrs, or for longer deployments, LiMnO₂ cells to achieve more than 2000 mA-hrs of operational capacity. Actual total usage time of the internal batteries is a function of several parameters. These include nominal water temperature, sequence timing, sample periods, and total deployment duration.

WARNING!

Pin 6 is always “hot.” Be sure to keep the dummy plug on internal battery units when not in use.

For even greater deployment capability contact WET Labs for information on external battery packs.

1.2.3 External Thermistor

ECO meters are optionally equipped with an external thermistor. The thermistor is calibrated at WET Labs and the calibration coefficients are supplied on the instrument's calibration sheets. Thermistor output is in counts and can be converted into engineering units using the instrument's device file and ECOView software or the raw data can be converted in the user's software (e.g. MATLAB or Excel) using the calibration equation:

$$\text{Temperature (deg C)} = (\text{Output} * \text{Slope}) + \text{Intercept}$$

1.2.4 Pressure Sensor

ECO meters are optionally equipped with a strain gauge pressure sensor. The pressure sensor is calibrated at WET Labs and the calibration coefficients are supplied on the instrument's calibration sheets. Pressure sensor output is in counts and can be converted into engineering units using the instruments device file and ECOview software or the raw data can be converted in the user's software (e.g. MATLAB or Excel) using the calibration equation:

$$\text{Relative Pressure (dbar)} = (\text{Output} * \text{Slope}) + \text{Intercept}$$

Please note that strain gauge pressure sensors are susceptible to atmospheric pressure changes and should be “zeroed” on each deployment or profile. The calibration equation for pressure above should be used first to get the relative pressure and the cast offset should then be subtracted to get the absolute pressure:

$$\text{Absolute Pressure (dbar)} = \text{Relative Pressure (dbar)} - \text{Relative Pressure at Atmospheric/Water interface (dbar)}$$

WARNING!

Do not exceed the pressure sensor's depth rating (see calibration sheet).

Pressure Sensor Maintenance

A plastic fitting filled with silicone oil provides a buffer between the pressure transducer and seawater. The transducer is both sensitive and delicate. Following the procedures below will ensure the best results and longest life from your pressure sensor.

Pressure is transmitted from the water to the stainless steel transducer diaphragm via a plastic fitting filled with silicone oil. The inert silicone oil protects the pressure sensor from corrosion, which would occur after long exposure to salt water. The fitting will generally prevent the oil from escaping from the reservoir into the water. However, you may occasionally wish to ensure that oil remains in the reservoir on top of the transducer.

WARNING

Never touch or push on the transducer.

1. Thoroughly clean the top of the instrument.
2. Completely remove the white nylon Swagelock fitting using a 9/16-in. wrench.
3. Check for obstructions in the tiny hole. Blow clear with compressed air or use a small piece of wire.
4. Wipe clean the o-ring at the base of the Swagelock fitting.
5. Screw the Swagelock fitting into the end flange until finger tight.
6. Tighten it an additional 1/8 turn using a wrench only if necessary.
7. Wipe up any excess oil.

1.3 Delivered Items

The standard ECO delivery consists of the following:

- the instrument itself
- this user's guide
- ECOView user's guide
- ECOView host program and device file (on CD)
- instrument-specific calibration sheet
- protective cover for optics
- Fluorescent sticks for bench testing
- Non-battery units only: stainless steel mounting bracket and hardware (See Appendix A for details)

Spare Parts

- Internal battery units: six 9-V Lithium batteries (installed)
Additional spare parts for battery units only:
 - Two end flange O-rings (size 224) and two vent plug O-rings (size 010)
 - Two jacking screws for connector flange removal
 - One 3/32-in. hex key for jacking screws
 - Jumper plug for autonomous operation
 - Three pre-cut segments (7 inches) of 0.036-inch diameter monofilament for end flange
 - Three pre-cut segments (0.250 inches) of 0.094-inch diameter white nylon bar stock for replacing the white plastic dowel pin.

2. Specifications

Specifications include all optical parameters; depending on the configuration ordered, not all scattering and fluorometer specifications will apply.

Model	Triplet	Triplet-B
Mechanical		
<i>Diameter</i>	6.3 cm	6.3 cm
<i>Length</i>	12.7 cm	25.4 cm
<i>Weight in air</i>	0.4 kg	0.96 kg
<i>Weight in water</i>	0.02 kg	0.14 kg
<i>Material</i>	Acetal co-polymer	
Environmental		
<i>Temperature range</i>	0–30 deg C	
<i>Depth rating</i>	600 m	300 m
Electrical		
<i>Digital output resolution</i>	12 bit	
<i>Internal data logging</i>	Yes	
<i>Internal batteries</i>	No	Yes
<i>Connector</i>	MCBH6M	MCBH6M, MCBH3F
<i>Input</i>	7–15 VDC	
<i>Current, typical</i>	60 mA	
<i>Current, sleep</i>	140 μ A	
<i>Data memory</i>	77,000 samples	
<i>Sample rate</i>	User selectable to 4 Hz	
<i>RS-232 output</i>	19200 baud	
<i>Linearity(all)</i>	99% R ²	

Optical	
<i>Scattering wavelengths</i>	470, 532, or 650 nm
<i>Range, typical</i>	0–5 m ⁻¹
<i>Sensitivity, all</i>	0.003 m ⁻¹
<i>Chlorophyll EX/EM</i>	470/695 nm
<i>Sensitivity</i>	0.025 μ g/l
<i>Range, typical</i>	0–50 μ g/l
<i>CDOM EX/EM</i>	370/460 nm
<i>Sensitivity</i>	0.28 ppb
<i>Range, typical</i>	0–375 ppb
<i>Uranine EX/EM</i>	470/530 nm
<i>Sensitivity</i>	0.15 ppb
<i>Range, typical</i>	0–300 ppb
<i>Rhodamine EX/EM</i>	540/570 nm
<i>Phycocyanin EX/EM</i>	630/680 nm
<i>Phycoerythrin EX/EM</i>	540/570 nm
<i>Sensitivity</i>	0.09 ppb
<i>Range, typical</i>	0–175 ppb

3. Instrument Operation

Please note that certain aspects of instrument operation are configuration-dependent. These are noted where applicable within the manual. *ECO* sensors can be used in a moored or profiling mode, with or without a host computer/data logger. The *ECOs* are versatile instruments, capable of operating under a variety of user-selected settings.

Units with CDOM measurement: UV LED Safety Note

- UV LEDs emit intense UV light during operation.
- Do not look directly into a UV LED while it is in operation, as it can be harmful to the eyes, even for brief periods.
- If it is necessary to view a UV LED, use suitable UV-filtered glasses or goggles to avoid damage to the eyes.
- Keep UV LEDs and products containing them out of the reach of children.
- Take appropriate precautions, including those above, with pets or other living organisms that might suffer injury or damage from exposure to UV emissions.



This label is affixed to all products containing UV LEDs.

3.1 Initial Checkout

Supplied from the factory, *ECOs* are configured to begin continuously sampling upon power-on. Electrical checkout of *ECO* is straightforward.

Connect the 6-socket connector on the optional test cable to the instrument to provide power to the LEDs and electronics (see Section 1 for a diagram of the pinouts of *ECO* Triplet). Connect the battery leads on the test cable to the 9V battery supplied with the meter. Light should emanate from the meter.

3.2 Operating the Sensor for Data Output

Note

ECO scattering meters are sensitive to AC light. Before making measurement, turn AC lighting off.

1. Connect the 6-socket connector to the instrument to provide power to the LEDs and electronics. Connect the DB-9 connector to a computer with the ECOView host program installed on it.

WARNING!

Always use a regulated power supply to provide power to *ECO* sensors if not using the 9V battery provided with the test cable: power spikes may damage the meter.

-
2. Start ECOView. Select the appropriate COM Port and Device File. Supply power to the meter, then click on the **Start Data** button. Output will appear in the Raw Data window. Test the instrument's signal using the fluorescent stick. *ECO* is sensitive to room lighting; for best results, perform test in ambient light only (turn off AC lighting). Remove the protective cover. Hold the fluorescent stick 1–4 cm above the optical paths in an orientation that maximizes exposure of the stick. (Parallel with the beams, not intersecting them). The signal will increase toward saturation (maximum value on characterization sheet). The sensor will operate until you select **Stop Data** in ECOView, or until it completes the requested samples.

3. Check the settings for the ECO and change if necessary. ECOView factory settings for continuous operation:
 - Set Number of Samples = 0
 - Set Number of Cycles = 0.
4. If the meter does not light after performing step 3, check the battery. Replace if necessary, perform steps 2 and 3 to verify communication. If it still does not light, contact WET Labs.

Refer to the ECOView User's Guide for details about using the software.

3.3 Deployment

Once power is supplied, the unit is ready for submersion and subsequent measurements. Some consideration should be given to the package orientation. Do not face the sensor directly into the sun or other bright lights. For best output signal integrity, locate the instrument away from significant EMI sources.

Caution

The Triplet should be mounted so that the LED source will not “see” any part of a cage or deployment hardware. This will affect the sensor's output.

Other than these basic considerations, one only needs to make sure that the unit is securely mounted to whatever lowering frame is used and that the mounting brackets are not damaging the unit casing. The instrument can be used in a moored or profiling mode.

3.4 Upkeep and Maintenance

We highly recommend that ECO meters be returned to the factory annually for cleaning, calibration and standard maintenance. Contact WET Labs or visit our website for details on returning meters and shipping.

The *ECO* Triplet is compact device and its maintenance can be easily overlooked. However, it is a precision instrument and does require a minimum of routine upkeep. After each cast or exposure of the instrument to natural water, flush the instrument with clean fresh water, paying careful attention to the sensor face. Use soapy water to cut any grease or oil accumulation. Gently wipe clean with a soft cloth. The sensor face is composed of ABS plastic and optical epoxy and can easily be damaged or scratched.

WARNING!

Do not use acetone or other solvents to clean the sensor.

At the end of an experiment, the instrument should be rinsed thoroughly, air-dried and stored in a cool, dry place.

4. Triplet-B: Using Internal Batteries

ECO meters with internal batteries can be powered in several ways.

1. The meter can be powered from the six-pin bulkhead connector using the optional test cable or from an external source. Communication is possible in this mode.
2. Alternatively, the meter can be powered using a jumper plug in the three-socket bulkhead connector. This is particularly useful for moored applications. The meter will run according to its stored settings.
3. If the jumper plug is in place on the meter and supplying power and the test cable is connected, power will be supplied by the equipment supplying the highest voltage. To conserve the internal batteries, it is advisable to use the test cable and an external power source set to 10–15 V.

4.1 Removing End Flange and Batteries

WARNING!

Changing the batteries will require opening the pressure housing of the ECO sensor. Only people qualified to service underwater oceanographic instrumentation should perform this procedure. If this procedure is performed improperly, it could result in catastrophic instrument failure due to flooding or in personal injury or death due to abnormal internal pressure as a result of flooding.

WET Labs Inc. disclaims all product liability from the use or servicing of this equipment. WET Labs Inc. has no way of controlling the use of this equipment or of choosing qualified personnel to operate it, and therefore cannot take steps to comply with laws pertaining to product liability, including laws that impose a duty to warn the user of any dangers involved with the operation and maintenance of this equipment. Therefore, acceptance of this equipment by the customer shall be conclusively deemed to include a covenant by the customer to defend and hold WET Labs Inc. harmless from all product liability claims arising from the use and servicing of this equipment. Flooded instruments will be covered by WET Labs Inc. warranties at the discretion of WET Labs, Inc.

1. Make sure the instrument is thoroughly dry.
2. Remove the dummy plug.
3. With connector end flange pointed downwards away from face, release seal from vent plug.
4. Remove any moisture from vent plug area.
5. Using needle nose pliers, remove filament from end flange.
6. Lift flange from pressure housing until seal is broken. The jacking screws can be used to “push” the flange from the pressure housing and then can be removed or left in the end flange.
7. Remove any excess moisture from flange–can seal area.

8. Work end flange out of pressure housing and remove any residual moisture. Remove the gray foam spacer and the neoprene insulator.
9. The battery pack is connected to the processor boards by a six-pin Molex connector: do NOT pull too hard or far on the battery pack or it will come unplugged and the unit will need to be returned to WET Labs.
10. Gently pull the white cord at the loop to remove the battery pack from the pressure housing.
11. Remove the black plastic protectors from the ends of the long screws securing the batteries.
12. Loosen and remove the screws (3/16-in slotted driver).

4.2 Replacing End Flange and Batteries

1. Replace the batteries.
2. Re-install the screws:
 - Align the groove in each of the plates so the six-wire extension bundle will fit in it along its length.
 - Be careful not to cross-thread into the bottom end plate nor to over-tighten the screws.
 - If they are too tight, the fiber washers that act as separators between the batteries will flex.
 - Make sure there are equal amounts of screw threads protruding from the bottom end plate when they are secure. This will ensure the pack is straight and will fit into the pressure housing with no difficulty.
3. Re-install the black plastic protective covers on the ends of the screws.
4. Remove and check the pressure housing O-ring for nicks or tears. Replace if necessary. Before re-installing, apply a light coat of vacuum grease on the O-ring.
5. Carefully replace the battery pack in the pressure housing. Place the neoprene insulator on the battery assembly and lay the white cord on the top.
6. Plug in the two-pin, then the six-pin Molex connectors. Sensor operation can now be tested if desired.
7. Align the hole in the end flange (NOT the jack screw holes) with the white dowel pin. While coiling the six wire bundle and making sure none are pinched between the end flange and the pressure housing, position the flange on the housing. Leave space to re-insert the gray foam spacer, making sure the cut-out accommodates the vent plug screw.
8. Push the end flange all the way on to the pressure housing, making sure no wires are pinched. Be sure the vent plug does not pop up. If it does, you'll need to re-position the foam spacer.
9. Re-insert the monofilament.

4.3 Checking Vent Plug

If there is fouling on the vent plug, it should be cleaned and the two 010 O-rings replaced. Otherwise, this mechanism should be maintenance-free.

WARNING!

The pressure housing is made of plastic material that scratches easily. Do not let the screwdriver slip and scratch the can when removing or replacing the vent plug. Use a toothpick (something softer than the plastic) to remove the O-rings from the vent plug.

1. Pull vent plug out about half way; hold plug while unscrewing the truss screw. When screw is removed, pull vent plug from end flange.
2. “Pinch” bottom O-ring around vent plug to form a small gap you can work a toothpick into. Use the toothpick to help roll the bottom O-ring off the plug.
3. Perform the same procedure with the top O-ring.
4. Clean the vent plug and vent plug hole using a dry lint-free tissue or cotton swab.
5. Lightly coat two undamaged or new O-rings with silicon grease. Install the top O-ring (nearest to large end of plug) first, then the bottom one.
6. Insert vent plug into its hole in the end flange and hold it while inserting the truss screw. Rotate the vent plug to begin tightening the screw. Finish tightening using a screwdriver, being careful not to overtighten truss screw.

Note

A portion of the truss screw head has been removed to allow for venting in case of pressure buildup.

5. Data Analysis

Raw data from the *ECO* meter is output in counts from the sensor, ranging from 0 to 4120 +/- 5. The ECOView host program will automatically perform the necessary calculations for both scattering and fluorescence.

- Calibration yields scattering data in the form of volume scattering coefficients, $\beta(\theta, \lambda)$ with units of $\text{m}^{-1} \text{sr}^{-1}$, where θ is angle and λ is wavelength.
- Characterization yields fluorescence data in the form of $\mu\text{g/l}$ (chlorophyll), or ppb (other fluorescence measurements).

5.1 Scattering Data Corrections

Attenuation coupling—For the population of photons scattered within the remote sample volume in front of the sensor face, there is attenuation along the path from the light source to the sample volume to the detector. This results in the scattering measurements being underestimates of the true volume scattering in the hydrosol. Corrected volume scattering coefficients can be obtained by accounting for the effect of attenuation along an average pathlength. This average pathlength was numerically solved in the weighting function determinations developed by Dr. Ron Zaneveld that are used in the calibration procedures.

Since the calibration of the *ECO*-VSF uses microspherical scatterers, the component of attenuation that can be attributed to scattering is incorporated into the scaling factor, i.e., the calibration itself. Thus, only absorption of the incident beam needs to be included in the correction.

The dependence on absorption, a , is determined as follows, where the measured scattering function at a given value of a , $\beta_{\text{meas}}(\text{angle}, a)$, is corrected to the value for $a = 0 \text{ m}^{-1}$, $\beta_{\text{corr}}(117^\circ, a=0)$:

$$\beta_{\text{corr}}(117^\circ, a=0) = \beta_{\text{meas}}(117^\circ, a) \exp(0.0391a)$$

Absorption can be measured with an ac-9 device. For each scattering wavelength, the matching absorption coefficient must be used from the ac-9. Because the *ECO* C3 scattering component incorporates short pathlengths and relatively small scattering volumes in its measurements, this attenuation error is typically small, about 4 percent at $a = 1 \text{ m}^{-1}$.

Temperature correction—Output from an LED reference detector is provided, which gives an indication of relative LED intensity during operation. Work is presently under way to incorporate this signal as an ongoing correction for measurements. Largest expected deviations in the calibration coefficients are about 10 percent in the temperature range 0–28 degrees C. Note that these errors become more pronounced for very clear waters. If the instrument is planned for use in clear water environments at the ends of this temperature range, it is recommended that a request be made for calibration data to be collected as close to the expected environmental temperature as possible.

5.2 Derived Parameters

5.2.1 Volume Scattering of Particles

The corrected volume scattering of particles, $\beta(117^\circ, \lambda)$ values represent total volume scattering, i.e., scattering from particles and molecular scattering from water. To obtain the volume scattering of particles only, subtract the volume scattering of water, $\beta_w(117^\circ, \lambda)$:

$$\beta_p(117^\circ, \lambda) = \beta(117^\circ, \lambda) - \beta_w(117^\circ, \lambda)$$

where $\beta_w(117^\circ, \lambda)$ is obtained from the relationship (from Morel 1974):

$$\beta_w(\theta, \lambda) = 1.38(\lambda/500\text{nm})^{-4.32} (1 + 0.3S/37) 10^{-4} (1 + \cos^2\theta(1-\delta)/(1+\delta)) \text{m}^{-1} \text{sr}^{-1}, \delta = 0.09$$

where S is salinity.

For total scattering of pure water,

$$b_w(\lambda) = 0.0022533 (\lambda/500\text{nm})^{-4.23}.$$

For total scattering of seawater (35–39 ppt),

$$b_{sw}(\lambda) = 0.0029308 (\lambda/500\text{nm})^{-4.24}.$$

For backscattering by water, divide b_w or b_{sw} by 2. The units for the b coefficients are (10^{-4}m^{-1}).

5.2.2 Backscattering Coefficients

Particulate backscattering coefficients, $b_{bp}(\lambda)$ with units of m^{-1} , can be determined through estimation from the single measurement of $\beta_p(117^\circ, \lambda)$ using an X factor:

$$b_{bp} = 2\pi X \beta_p(117^\circ)$$

From measurements of the volume scattering function with high angular resolution in a diversity of water types, Boss and Pegau (2001) have determined X to be **1.1** (Boss, E., and S. Pegau, 2001). The relationship of scattering in an angle in the back direction to the backscattering coefficient, *Applied Optics*). This factor estimates b_{bp} with an estimated uncertainty of 4 percent. The conversion can be used for $\beta(117^\circ)$ measurements made at any visible wavelength.

To compute total backscattering coefficients, $b_b(\lambda)$ with units of m^{-1} , the backscattering from pure water, $b_{bw}(\lambda)$ (see above), needs to be added to $b_{bp}(\lambda)$:

$$b_b(\lambda) = b_{bp}(\lambda) + b_{bw}(\lambda).$$

5.2.3 Fluorescence Response

The scale factor is factory-calculated by obtaining a consistent output of a solution with a known concentration, then subtracting the meter’s dark counts. The scale factor, dark counts, and other characterization values are on the instrument’s characterization sheet.

For chlorophyll, WET Labs uses the chlorophyll equivalent concentration (CEC) as the signal output using a fluorescent proxy approximately equal to 25 µg/l of a *Thalassiosira weissflogii* phytoplankton culture.

$$\text{Scale Factor} = 25 \mu\text{g/l} \div (\text{CEC} - \text{dark counts})$$

$$\text{Example: } 25 \div (3198 - 71) = 0.0080.$$

For CDOM, uranine (fluorescein), and phycoerythrin, WET Labs uses a solution where x is the meter output in counts of the concentration of the solution used during instrument characterization.

$$\text{Scale Factor} = 308 \text{ ppb} \div (x - \text{dark counts})$$

$$\text{Example: } 308 \div (4148 - 56) = 0.0753.$$

The scale factor is then applied to the output signal to provide the direct conversion of the output counts to chlorophyll concentration. WET Labs supplies a scale factor that can be found on the instrument-specific calibration sheet that ships with each meter. While this constant can be used to obtain approximate values, field calibration is highly recommended.

Because of the varied environments in which each user will work, it is important to perform characterizations using similar seawater as you expect to encounter *in situ*. This will provide an accurate dark count value, equivalent phytoplankton types and similar physiological conditions for calculating the scale factor, thereby providing an accurate and meaningful calibration. Once a zero point has been determined and a scale factor established, obtaining a “calibrated” output simply involves subtracting the digital dark counts value from output when measuring a sample of interest and multiplying the difference by the instrument scaling factor:

$$[\text{XX}]_{\text{sample}} = (C_{\text{output}} - C_{\text{dc}}) * \text{Scale Factor}$$

where

$[\text{XX}]_{\text{sample}}$ = concentration of a sample of interest (µg/l or ppb)

C_{output} = raw counts output when measuring a sample of interest

C_{dc} = dark counts, the measured signal output of meter in clean water with black tape over the detector

Scale factor = multiplier in µg/l/counts or ppb/counts

6. Calibration/Characterization and Testing

Prior to shipment, each *ECO* is calibrated/characterized and tested to ensure it meets the instrument's stated specifications. Scattering channel(s) are typically configured for a measurement range of 0–5 m⁻¹. Fluorescence channel(s) are characterized using a specific concentration of a fluorescing material that yields a scaled µg/l or ppb output range:

Chlorophyll:	0.02–50 µg/l
CDOM:	0.3–375 ppb
Phycoerythrin and rhodamine:	0.1–175 ppb
Uranine (fluorescein):	0.002–5 ppm

6.1 Scattering Calibration

Each meter ships with a calibration sheet that provides instrument-specific calibration information, derived from the steps below.

1. For a given scattering centroid angle (θ_c), compute the weighting function $W(\theta, \theta_c)$, by numerical integration of sample volume elements according to the sensor geometry.
2. Determine scattering phase functions, $\beta(\theta, \lambda)/b(\lambda)$, for the polystyrene bead microsphere calibration particles by weighting volume scattering functions computed from Mie theory according to the known size distribution of the polystyrene bead microsphere polydispersion and normalizing to total scattering.
3. By convolving $W(\theta, \theta_c)$ with $\beta(\theta, \lambda)/b(\lambda)$, compute the normalized volume scattering coefficient for each measurement angle, $\beta(\theta_c)/b$, with units of sr⁻¹ $\beta(\theta_c)/b$ for 2.00-micron diameter polystyrene bead microspheres.
4. Experimentally obtain raw scattering counts simultaneously with attenuation coefficients (C_p , using an ac-9) for a concentration series of the polystyrene bead microsphere polydispersion. Absorption by the calibration particles is assumed negligible.
5. Obtain b/counts from the slope of a linear regression between C_p (equivalent to b for the beads) and counts.
6. Multiplying the experimental b/counts by the theoretical $\beta(\theta_c)/b$ yields the calibration scaling factor, SF.
7. To obtain $\beta(\theta_c)$, subtract the dark counts from the raw counts measured, then multiply by SF.
8. This test also provides a measure of the inherent opto-electronic noise level of the instrument. A standard deviation from the average number of counts on a 1 minute data file is taken. This is translated into the resolution of $\beta(\theta_c)$ (minimum detectable signal change) in units of m⁻¹ sr⁻¹.

Definition of Terms

β : phase function

θ : angle

W : weighting function

C_p : particulate attenuation coefficient

m^{-1} : per meter

b : total scattering coefficient

θ_c : centroid angle

λ : wavelength

SF : Scaling Factor

sr^{-1} : per steradian

6.2 Fluorometer Characterization

Gain selection is performed at WET Labs by setting several gain settings in the instrument and running a chlorophyll (or proxy) dilution series to determine the zero voltage offset and to ensure that the dynamic range covers the measurement range of interest. The dilution series also establishes the linearity of the instrument's response. As is the case with other fluorometers, the user must perform a detailed characterization to determine the actual zero point and scale factor for his/her/particular use.

6.3 Testing

Dark Counts: The meter's baseline reading in the absence of source light is the dark count value. This is determined by measuring the signal output of the meter in clean, de-ionized water with black tape over the detector.

Pressure: To ensure the integrity of the housing and seals, *ECO* meters are subjected to a wet hyperbaric test before final testing. The testing chamber applies a water pressure of at least 50 PSI.

Mechanical Stability: Before final testing, the *ECO* meters are subjected to a mechanical stability test. This involves subjecting the unit to mild vibration and shock. Proper instrument functionality is verified afterwards.

Electronic Stability: This value is computed by collecting a sample once every 5 seconds for twelve hours or more. After the data is collected, the standard deviation of this set is calculated and divided by the number of hours the test ran. The stability value must be less than 2.0 counts/hour.

Noise: Noise is computed from a standard deviation over 60 samples. These samples are collected at one-second intervals for one minute. A standard deviation is then performed on the 60 samples, and the result is the published noise on the calibration form. The calculated noise must be below 2 counts (3 counts for CDOM).

Voltage and Current Range Verification: To verify the *ECO* operates over the entire specified voltage range (7–15 V), a voltage test is performed at 7 and 15V, and the current draw and operation is observed. The current must remain constant at both 7 and 15V.

7. Terminal Communications

As an alternative to ECOView Host software, *ECO* sensors can be controlled from a terminal emulator or customer-supplied interface software. This section outlines hardware requirements and low-level interface commands for this type of operation.

7.1 Interface Specifications

- baud rate: 19200
- data bits: 8
- parity: none
- stop bits: 1
- flow control: none

7.2 Command List

Command	Parameters passed	Description
!!!!	none	Stops data collection; allows user to input setup parameters. Note that if the meter is in a sleep state, the power must be turned off for a minute, then powered on while the “!” key is held down for several seconds. If this does not “wake” the meter, refer to the ECOView user’s guide Operation Tip to “wake” a meter in a low power sleep state to enable inputting setup parameters.
\$ave	single number, 1 to 65535	Number of measurements for each reported value
\$clk	24hr format time, hhmmss	Sets the time in the Real Time Clock
\$dat	date, format ddmmyy	Sets the date in the Real Time Clock
\$emc	none	Erases the Atmel memory chip, displays menu when done
\$get	none	Reads data out of Atmel memory chip. Prints "etx" when completed.
\$int	24hr format time, hhmmss	Time interval between packets in a set
\$mnu	none	Prints the menu
\$pkt	single number, 0 to 65535	Number of individual measurements in each packet
\$rec	1 (on) or 0 (off)	Enables or disables recording data to Atmel memory chip
\$rls	none	Reloads settings from flash
\$run	none	Executes the current settings
\$set	single number, 0 to 65535	Number of packets in a set
\$sto	none	Stores current settings to internal flash
\$ugl	0 to 255	µg/l conversion value (calculates slope x 10,000). Fluorometer only.

8. Device and Output Files

Each meter is shipped with a CD containing the meter-specific device file, a sample output file, characterization information, and the applicable user's guides.

The ECOView host program requires a device file to provide engineering unit outputs for any of its measurements. Except for the first line in the device file, all lines of information in the device file that do not conform to one of the descriptor headers will be ignored. Every ECOView device file has three required elements: Plot Header, Column Count Specification, and Column Description.

8.1 Plot Header

The first line in the device file is used as the plot header for the ECOView plots.

8.2 Column Count Specification

The Column Count Specification identifies how many columns of data to expect. It follows the format "Column=n." The Column Count Specification must be present before any of the Column Descriptions are listed.

8.3 Column Description

Every column in the ECO meter's output must have a corresponding Column Description in the device file. The following notation is used in identifying the elements of each Column Description.

- x = the column number, starting with 1 as the 1st column
- sc = scale
- dc = dark count, same as offset
- off = offset, same as dark count
- mw = measurement wavelength—wavelength used by the sensor for its measurement
- dw = display wavelength—display wavelength—wavelength/color range (380–780 nm)
- v = measured volts dc

Fluorescence Measurements

Chl=	x	sc	off
IENGR=	x	sc	off
Phycoerythrin=	x	sc	off
Phycocyanin=	x	sc	off
Rhodamine=	x	sc	off
Cdom=	x	sc	off

Scattering Measurements

Lambda=x	sc	off	mw	dw	Scatter sensor column
----------	----	-----	----	----	-----------------------

Miscellaneous

Date=x	DD/MM/YY
Time=x	HH:MM:SS
N/U=x	The column is Not Used
N/U=x	The column is Not Used

There are several default parameters that ECOView uses in the scatter calculations for the BB meters. These parameters are (a) salinity; (b) water type, fresh or sea water; (c) Chi ; and (d) theta, the measurement angle. The user may change these using the following device file elements (the values shown are the defaults).

```
Salinity=23    23 ppt
Water=Sea     Meter is assumed to be in salt water (Use "Pure" for fresh water)
XFactor=1.1   X Factor Correction Value
Theta=117     Back scattering angle
```

8.4 Output and Device File Formats

Because of the variety of configurations available for this custom instrument, each Triplet ships with its instrument-specific sample output file and device file on the accompanying CD, and in the Appendix.

FL3 Sample Device File

```
ECO FL3-xxx
Created on: xx/xx/xx

Columns=9
Date=1
Time=2
N/U=3
FL_type_1_ =4      0.xxxxx      1xx
N/U=5
FL_type_2_ =6      0.xxxxx      1xx
N/U=7
FL_type_3_ =8      0.xxxxx      1xx
N/U=9
```

FL3 Sample Output Format

Date	Time	λ	chl-sig	λ	pe-sig	λ	cdom-sig	therm
------	------	-----------	---------	-----------	--------	-----------	----------	-------

BB2FL Sample Device File

```
ECO BB2FL-xxx
Created on: 10/6/05

Columns=9
Date=1
Time=2
N/U=3
Lambda=4 0.0026      51.0  470  470
N/U=5
Lambda=6 0.0011      55.5  650  650
N/U=7
CHL=8      0.0181      48.0
N/U=9
```

BB2FL Sample Output Format

Date	Time	λ	470 sig	λ	660 sig	λ	chl sig	therm
------	------	-----------	---------	-----------	---------	-----------	---------	-------

BBFL2 Sample Device File

ECO BBFL2-xxx
Created on: xx/xx/xx

```
Columns=9
Date=1
Time=2
N/U=3
Lambda=4      1.xxxx-06  1xx   xxx   xxx
N/U=5
FL_type_1_ =6  0.xxxx           1xx
N/U=7
FL_type_2_ =8  0.xxxx           1xx
N/U=9
```

BBFL2 Sample Output Format

Date	Time	λ 660 sig	λ chl sig	λ cdom sig	therm
------	------	-------------------	-------------------	--------------------	-------

BB3 Sample Device File

ECO BB3-xxx
Created on: xx/xx/xx

```
Columns=9
Date=1
Time=2
N/U=3
Lambda=4      1.xxxx-06  1xx   xxx   xxx
N/U=5
Lambda=6      1.xxxx-06  1xx   xxx   xxx
N/U=7
Lambda=8      1.xxxx-06  1xx   xxx   xxx
N/U=9
```

BB3 Sample Output Format

Date	Time	λ 470 sig	λ 532 sig	λ 660 sig	therm
------	------	-------------------	-------------------	-------------------	-------

Appendix A: Mounting Bracket Drawing

Note that the mounting bracket is available only for units without internal batteries.

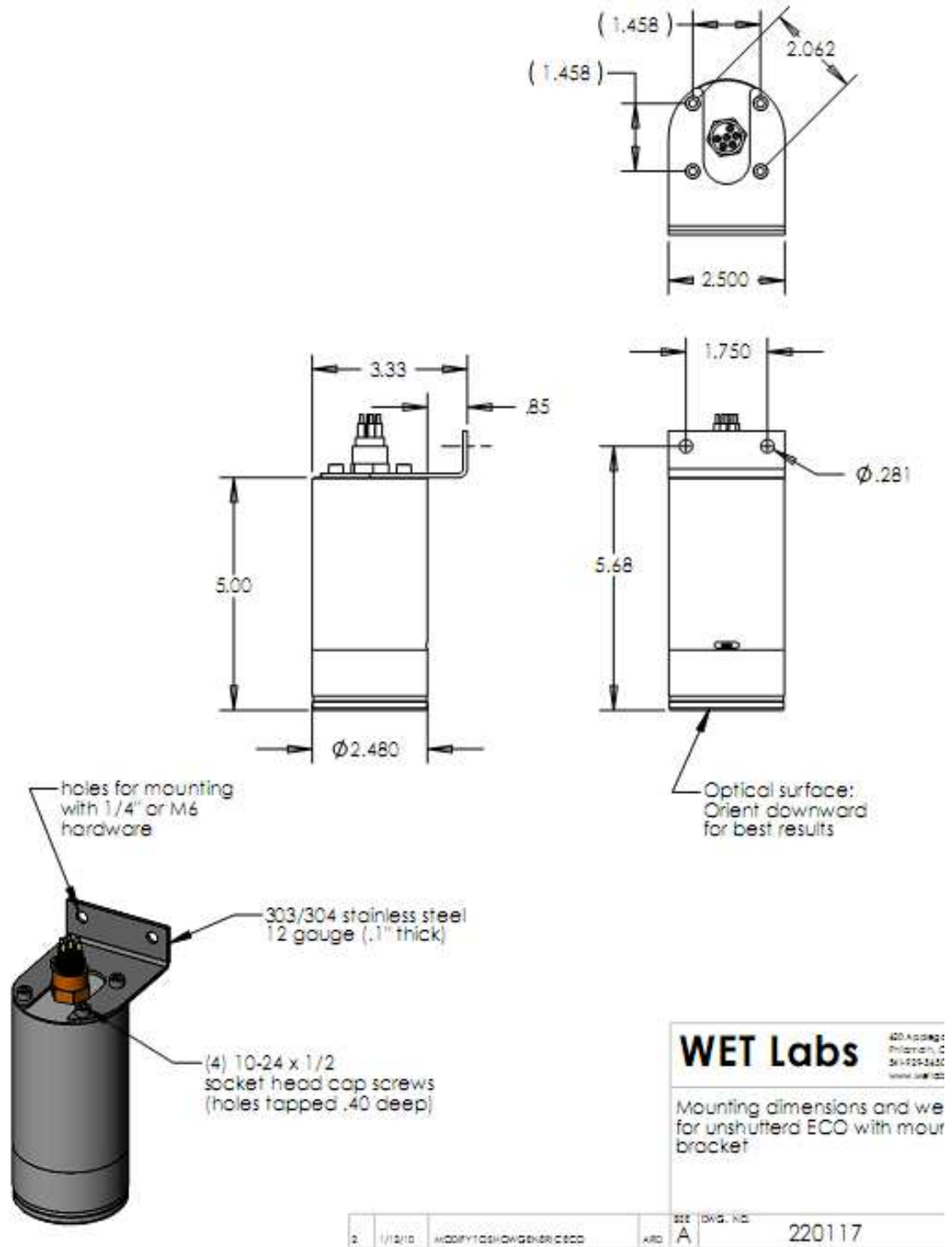

Revision History

Revision	Date	Revision Description	Originator
A	11/24/03	New document (DCR 347)	H. Van Zee, D. Whiteman
B	3/10/04	Add new test cable description, operational description, mounting diagram (DCR 381)	A. Derr, D. Whiteman
C	5/11/04	Remove pin 6 from warning in section 1 (DCR 390)	I. Walsh
D	6/29/04	Update Specifications (DCR 400)	I. Walsh
E	9/28/04	Add text for optional thermistor and pressure sensor (DCR 429)	I. Walsh
F	10/14/04	Add references to Lithium batteries for applicable models (DCR 433)	I. Walsh
G	12/7/05	Clarify data analysis section for fluorometer, add scattering calibration discussion (section 6) (DCR 477)	H. Van Zee, R. Watte, C. Wetzel
H	1/13/06	Clarify warranty statement (DCR 481)	A. Gellatly, S. Proctor
I	2/22/06	Clarify instrument equipment options (DCR 488)	H. Van Zee
J	5/31/06	Add annual maintenance recommendation (DCR 498)	S. Proctor
K	9/28/06	Update specifications (DCR 507)	M. Johnson
L	11/01/06	Correct Pressure Sensor and Thermistor output equations (DCR 509)	M. Johnson
M	9/7/07	Use one instead of two LEDs, (ECN 264) delete reference to refilling pressure sensor, update shipping requirements (DCR 531)	M. Johnson, H. Van Zee
N	7/10/08	Change dark counts derivation to reflect current production methodology (DCR 600)	A. Barnard, M. Johnson, H. Van Zee
O	9/9/08	Add phycocyanin spec, delete reference column (DCR 614)	I. Walsh
P	1/19/10	Correct mounting bracket dwg (DCR 690)	A. Hahn
Q	9/2/10	Add UV LED Safety note (DCR 713)	A. Barnard, H. Van Zee
R	9/21/10	Update LED and length specs (DCR 691)	H. Van Zee
S	5/9/11	Update optical specs (DCR 762) w/corrections made 5/17/11	M. Johnson, H. Van Zee