

SBE 37-SIP (RS-232) MicroCAT Reference Sheet

(see SBE 37-SIP MicroCAT User's Manual for complete details)

Sampling Modes

- **Autonomous sampling** – There are two types of Autonomous sampling.
 - Interval sampling:* At pre-programmed intervals, run pump for 1 second, sample, transmit data, store data in FLASH memory, and go to sleep.
 - Continuous sampling:* Continuously run pump, sample, transmit data, and store data in FLASH memory.
- **Polled sampling** – On command, run pump for 1 second, take 1 sample, and transmit data. Polled sampling is useful for integrating MicroCAT with satellite, radio, or wire telemetry equipment.
- **Serial Line Sync** - In response to a pulse on serial line, wake up, run pump for 1 second, sample, transmit data, store data in FLASH memory, and go to sleep. Easy method for synchronizing MicroCAT sampling with other instruments such as Acoustic Doppler Current Profilers (ADCPs) or current meters, without drawing on their battery or memory resources.

Setup

1. Install I/O cable; connect to computer serial port and power supply (9-24 VDC).
2. Double click on SeatermV2.exe. SeatermV2 opens; in Instruments menu, select *SBE 37 RS232*. Seaterm232 opens.
3. In Seaterm232's Communications menu, select Configure. Select Comm port and baud rate (factory set to 9600), and click OK.
4. Seaterm232 automatically connects to MicroCAT. As it connects, it sends **GetHD** and displays response, and then fills Send Commands window with list of commands for your MicroCAT.
5. Ensure all data has been uploaded from memory, and then send **InitLogging** to make entire memory available for recording. If **InitLogging** is not sent, data will be stored after last recorded sample.
6. Set Date and Time (**DateTime=**).
7. Establish setup and operating parameters. Parameters that control operation include **SampleMode=** and **AutoRun=**:
 - **SampleMode=1:** When commanded to sample, run pump and take 1 sample.
 - **SampleMode=2:** When commanded to sample, run pump and sample at intervals defined by **SampleInterval=**.
 - **SampleMode=3:** When commanded to sample, pump and sample continuously.
 - **AutoRun=Y:** When power applied, automatically sample as defined by **SampleMode=**.
 - **AutoRun=N:** When power applied, do not begin to automatically sample.

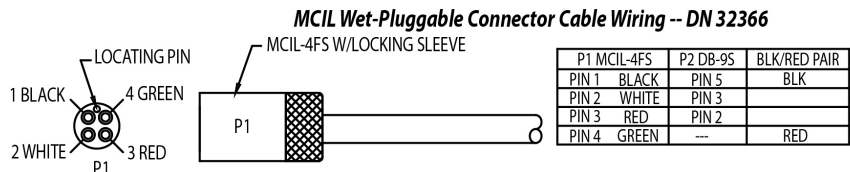
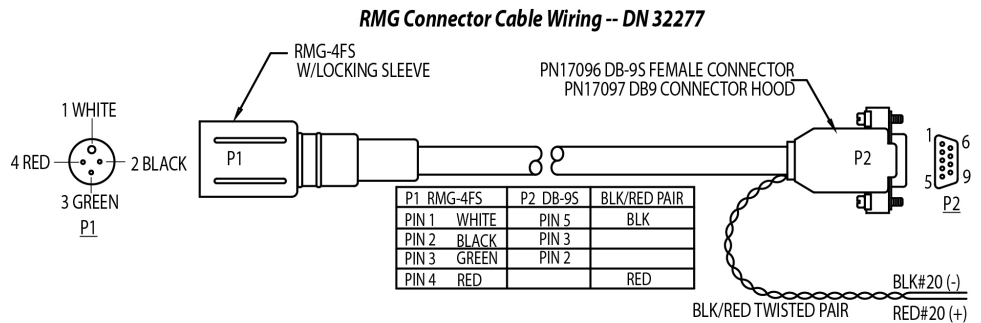

Deployment

1. Wiring - Install I/O cable and locking sleeve. Connect to computer serial port and power supply (9 - 24 VDC).
2. Mount MicroCAT, using Sea-Bird mounting hardware or customer-supplied mounting hardware. **MicroCAT is intended for deployment with connector at bottom for proper operation – see manual for details.**

Data Upload

1. Connect cable from MicroCAT to computer and power source.
2. Double click on SeatermV2.exe. SeatermV2 opens; in Instruments menu, select *SBE 37 RS232*. Seaterm232 opens.
3. In Seaterm232's Communications menu, select Configure. Select Comm port and baud rate (factory set to 9600), and click OK.
4. Seaterm232 automatically connects to MicroCAT. As it connects, it sends **GetHD** and displays response, and then fills Send Commands window with list of commands for your MicroCAT.
5. If sampling autonomously (logging), command MicroCAT to stop logging by sending **Stop**.
6. Click Upload menu to upload stored data.
7. Seaterm232 prompts you to run SBE Data Processing to convert uploaded .hex file to .cnv file for use by other modules in data processing software. Process file and review data to ensure all data has been uploaded.

Command Instructions and List

- Input commands in upper or lower case letters and register commands by pressing Enter key.
- If in quiescent (sleep) state, re-establish communications by clicking Connect in Communications menu or pressing Enter key.
- If a new command is not received within 2 minutes after completion of a command, MicroCAT returns to quiescent (sleep) state.
- MicroCAT sends an error message if invalid command is entered.

Shown below are the commands used most commonly in the field. See the Manual for complete listing and detailed descriptions.

CATEGORY	COMMAND	DESCRIPTION
Status	GetCD	Get and display configuration data.
	GetSD	Get and display status data.
	GetCC	Get and display calibration coefficients.
	GetEC	Get and display event counter data.
	ResetEC	Reset event counter.
	GetHD	Get and display hardware data.
	DS	Get and display status.
	DC	Get and display calibration coefficients.
General Setup	DateTime=mmddyyyyhhmmss	Set real-time clock month, day, year, hour, minute, second.
	BaudRate=x	x= baud rate (600, 1200, 2400, 4800, 9600, 19200, 38400, 57600, 115200). Default 9600.
	OutputExecutedTag=x	x=Y: output XML Executed and Executing tags. x=N: do not.
	ReferencePressure=x	x = reference pressure (decibars) (used when MicroCAT has no pressure sensor).
Pump Setup	QS	Quit session and place MicroCAT in quiescent (sleep) state.
	MinCondFreq=x	x= minimum conductivity frequency (Hz) to enable pump turn-on for sampling.
	PumpOn PumpOff	Turn pump on for testing or to remove sediment. Turn pump off, if turned on with PumpOn .
Memory Setup	StoreData=x	x=Y: Store data to FLASH memory when sampling. x=N: do not.
	InitLogging	Initialize logging to make entire memory available for recording.
	SampleNumber=x	x= sample number for last sample in memory. SampleNumber=0 equivalent to InitLogging .
Output Format Setup	OutputFormat=x	x=0: raw decimal data. x=1: converted decimal data. x=2: converted decimal data in XML. x=3: converted binary data. x=4: converted decimal data, alternate format. x=5: converted data, BSH format.
	OutputTime=x	x=Y: output date and time. x=N: do not.
	OutputSal=x	x=Y: output salinity (psu). x=N: do not.
	OutputSV=x	x=Y: output sound velocity (m/sec). x=N: do not.
	OutputDensity=x	x=Y: output local density (kg/m ³). x=N: do not.
	OutputDepth=x	x=Y: output depth (meters). x=N: do not.
Operating	Latitude=x	x= latitude (degrees) to use in depth calculation.
	SampleMode=x	x=1: When command to sample, run pump and take single sample. x=2: When command to sample, run pump and sample as defined by SampleInterval= . x=3: When command to sample, run pump and sample continuously.
	SampleInterval=x	x = interval between samples (6 - 21600 seconds) when SampleMode=2 .
	AutoRun=x	x=Y: When power applied, automatically sample as defined by SampleMode= . x=N: When power applied, do not begin to automatically sample.
	Start Stop	Start sampling, as defined by SampleMode= . Stop sampling. Must send Stop before uploading data.
Polled Sampling	TS	Run pump, take sample, store data in buffer, output data.
	TSH	Run pump, take sample, store data in buffer, do not output data.
	TSS	Run pump, take sample, store data in buffer and in FLASH memory, output data.
	TSN:x	Run pump continuously while taking x samples, output data.
	SL	Output last sample stored in buffer.
	SLT	Output last sample stored in buffer, then run pump, take new sample, store data in buffer.
Data Upload	GetSamples:b,e	Upload scan b to scan e , in format defined by OutputFormat= .
	DDb,e	Upload scan b to scan e , in alternate converted decimal form (OutputFormat=4) (regardless of user setup for OutputFormat=).
Calibration Coefficients	<i>See manual.</i>	