

SBE 37-SMP-IDO (RS-232) MicroCAT Reference Sheet

(see SBE 37-SMP-IDO MicroCAT User's Manual for complete details)

Sampling Modes

- **Autonomous sampling** – At pre-programmed intervals, wake up, run pump, sample, store data in FLASH memory, and go to sleep. If desired, data can also be transmitted real-time.
- **Polled sampling** – On command, run pump, take one sample, and send data to computer. Polled sampling is useful for integrating MicroCAT with satellite, radio, or wire telemetry equipment.
- **Serial line sync** – In response to a pulse on serial line, wake up, run pump, sample, store data in FLASH memory, and go to sleep. Data can also be transmitted real-time.

Setup

1. Install AA lithium cells (Note: **IDO MicroCATs use a battery pack with a yellow cover plate**):
 - A. *Remove connector end cap*: Wipe dry housing/end cap seam. Remove 2 cap screws from end cap, twist end cap counterclockwise, and pull out. Disconnect Molex connecting to battery pack. Wipe dry O-ring mating surfaces with lint-free cloth.
 - B. *Remove battery pack and install cells*: Loosen captured screw in battery pack cover. Use handle to lift pack out of housing. Keep handle upright. Unscrew cover plate. Roll 2 O-rings on side of pack out of grooves. Insert cells, and roll 2 O-rings back into grooves. Align pin on cover plate PCB with post hole, keep handle upright, and screw cover plate onto battery pack.
 - C. *Reinstall battery pack and connector end cap*: Align D-shaped opening and pins on shaft. Lower battery pack into housing; push gently to mate. Tighten captured screw to secure battery pack in housing. Remove water from O-rings and mating surfaces with lint-free cloth. Inspect O-rings and mating surfaces for dirt, nicks, and cuts. Clean as necessary. Apply light coat of O-ring lubricant to O-ring and mating surfaces. Plug Molex connector together. Fit end cap into housing. Reinstall 2 cap screws.
2. Install cable. Connect to computer serial port.
3. Double click on SeatermV2.exe. SeatermV2 opens; in Instruments menu, select *SBE 37 RS232*. Seaterm232 opens.
4. In Seaterm232's Communications menu, select Configure. Select Comm port and baud rate (factory set to 9600), and click OK.
5. Seaterm232 connects to MicroCAT, and sends **GetHD**.
6. Program MicroCAT for intended deployment (see other side of this sheet for *Command Instructions and List*):
 - A. Ensure all data has been uploaded, and then send **InitLogging** to make entire memory available for recording.
 - B. Set date and time (**DateTime=**), and establish logging parameters. Use one of following sequences to start logging:
 - **StartNow** to start logging now, sampling every **SampleInterval=** seconds.
 - **StartDateTime=** and **StartLater** to start logging at specified date and time, sampling every **SampleInterval=** seconds.
 - **SyncMode=Y** to place MicroCAT in serial line sync mode, so that a simple pulse on RS-232 line will initiate sample.

Deployment

1. Wiring – deploy with dummy plug or I/O cable (for external power and/or communication during deployment). Install locking sleeve.
2. Mount MicroCAT, using Sea-Bird or customer-supplied hardware.
MicroCAT is intended for deployment with connector at bottom for proper operation – see manual for details.

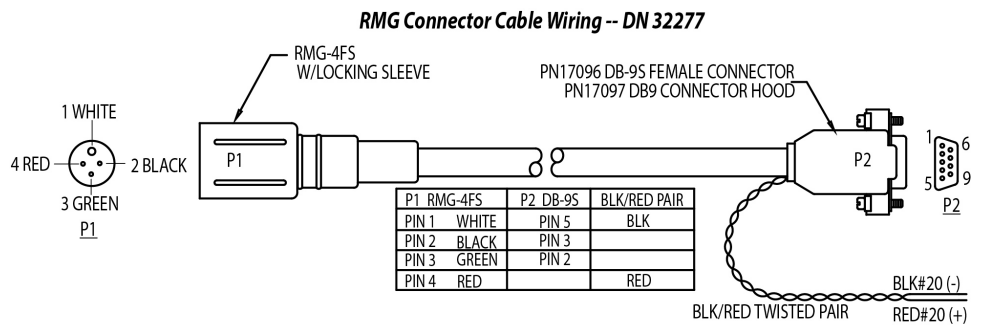

Data Upload

1. Connect cable from MicroCAT to computer.
2. Double click on SeatermV2.exe. SeatermV2 opens; in Instruments menu, select *SBE 37 RS232*. Seaterm232 opens.
3. In Seaterm232's Communications menu, select Configure. Select Comm port and baud rate (factory set to 9600), and click OK.
4. Seaterm232 connects to MicroCAT and sends **GetHD**.
5. If sampling autonomously (logging), command MicroCAT to stop logging by sending **Stop**.
6. If desired, reset baud to increase upload speed (**BaudRate=**). After first entry, MicroCAT changes to new baud, then waits for command to be sent again at new baud (In Seaterm232's Communications menu, select *Configure*. In dialog box, select new baud and click OK. Then retype command.). If it does not receive command again at new baud, it reverts to previous baud.
7. Click Upload menu to upload stored data.
8. Seaterm232 prompts you to run SBE Data Processing to convert uploaded .hex file to .cnv file for use by other modules in data processing software. Process file and review data to ensure all data has been uploaded.

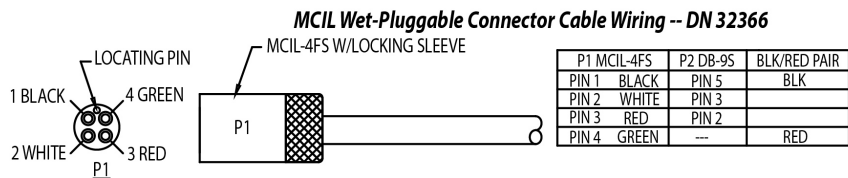

Command Instructions and List

- Input commands in upper or lower case letters and register commands by pressing Enter key.
- If in quiescent (sleep) state, re-establish communications by clicking Connect in Communications menu or pressing Enter key.
- If a new command is not received within 2 minutes after completion of a command, MicroCAT returns to quiescent (sleep) state.
- MicroCAT sends an error message if invalid command is entered.

Shown below are the commands used most commonly in the field. See the Manual for complete listing and detailed descriptions.

CATEGORY	COMMAND	DESCRIPTION
Status	GetCD	Get and display configuration data.
	GetSD	Get and display status data.
	GetCC	Get and display calibration coefficients.
	GetEC	Get and display event counter data.
	ResetEC	Reset event counter.
	GetHD	Get and display hardware data.
	DS	Get and display status.
General Setup	DC	Get and display calibration coefficients.
	DateTime= mmddyyyyhhmmss	Set real-time clock month, day, year, hour, minute, second.
	BaudRate=x	x= baud rate (600, 1200, 2400, 4800, 9600, 19200, 38400, 57600, or 115200). Default 9600.
	OutputExecutedTag=x	x=Y: Output XML Executed and Executing tags. x=N: Do not.
	TxRealTime=x	x=Y: Output real-time data while sampling in autonomous or serial line sync mode. x=N: Do not.
	ReferencePressure=x	x = reference pressure (decibars) (used when MicroCAT has no pressure sensor).
Pump Setup	QS	Quit session and place MicroCAT in quiescent (sleep) state. Data logging and memory retention not affected.
	MinCondFreq=	x= minimum conductivity frequency (Hz) to enable pump turn-on for sampling.
	AdaptivePumpControl=x	x=Y: Use <i>Adaptive Pump Control</i> methodology to calculate pump run time. x=N: Do not use <i>Adaptive Pump Control</i> , run pump for 3.5 sec before sampling (for testing).
	PumpOn	Turn pump on, for testing.
Memory Setup	PumpOff	Turn pump off, if turned on with PumpOn .
	InitLogging	Initialize logging to make entire memory available for recording.
Output Format Setup	SampleNumber=x	x= sample number for last sample in memory. SampleNumber=0 equivalent to InitLogging .
	OutputFormat=x	x=0: Output raw decimal data. x=2: Output converted decimal data in XML. x=1: Output converted decimal data.
	OutputSal=x	x=Y: output salinity (psu). x=N: do not.
Autonomous Sampling (Logging)	OutputSV=x	x=Y: output sound velocity (m/sec). x=N: do not.
	SampleInterval=x	x = interval between samples (10 - 21600 seconds). When commanded to start sampling with StartNow or StartLater , at x second intervals MicroCAT runs pump, takes sample, stores data in FLASH memory, transmits real-time data (if TxRealTime=Y), and goes to sleep.
	StartNow	Start logging now.
	StartDateTime= mmddyyyyhhmmss	Delayed logging start: month, day, year, hour, minute, second
	StartLater	Start logging at delayed start time.
Polled Sampling	Stop	Stop logging or stop waiting to start logging. Press Enter key before entering Stop . Must send Stop before uploading data.
	TS	Take sample, store data in buffer, output data.
	TSR	Take sample, store data in buffer, output data in raw decimal format.
	TPS	Run pump, take sample, store data in buffer, output data.
	TPSH	Run pump, take sample, store data in buffer, do not output data.
	TPSS	Run pump, take sample, store data in buffer and in FLASH memory, output data.
	TSN:x	Do not pump. Take x samples, output data.
	#iiTPSN:x	Run pump continuously while taking x samples and outputting data.
Serial Line Sync	SL	Output last sample stored in buffer.
	SLTP	Output last sample stored in buffer, then run pump, take new sample, and store data in buffer.
Data Upload	SyncMode=x	x=Y: Enable serial line sync mode. x=N: Disable serial line sync mode.
	GetSamples:b,e	Upload scan b to scan e , in format defined by OutputFormat= . Send Stop before sending.
Calibration Coefficients	DDb,e	Upload scan b to scan e , in converted decimal form (OutputFormat=1) (regardless of user setup for OutputFormat=). Send Stop before sending.
		See manual.