

SBE 16*plus*-IM SEACAT

*Conductivity and Temperature Recorder (pressure optional)
with Inductive Modem Interface*



User's Manual

Sea-Bird Electronics, Inc.
1808 136th Place NE
Bellevue, Washington 98005 USA
Telephone: 425/643-9866
Fax: 425/643-9954
E-mail: seabird@seabird.com
Website: www.seabird.com

Manual Version #014, 12/21/07
16plus-IM Digital Firmware Version 1.2c & later
16plus-IM Modem Firmware Version 1.1a & later
SIM Firmware Version 3.0 & later

Limited Liability Statement

Extreme care should be exercised when using or servicing this equipment. It should be used or serviced only by personnel with knowledge of and training in the use and maintenance of oceanographic electronic equipment.

SEA-BIRD ELECTRONICS, INC. disclaims all product liability risks arising from the use or servicing of this system. SEA-BIRD ELECTRONICS, INC. has no way of controlling the use of this equipment or of choosing the personnel to operate it, and therefore cannot take steps to comply with laws pertaining to product liability, including laws which impose a duty to warn the user of any dangers involved in operating this equipment. Therefore, acceptance of this system by the customer shall be conclusively deemed to include a covenant by the customer to defend, indemnify, and hold SEA-BIRD ELECTRONICS, INC. harmless from all product liability claims arising from the use or servicing of this system.

Table of Contents

Section 1: Introduction	5
About this Manual	5
How to Contact Sea-Bird	5
Quick Start	5
Unpacking SBE 16 <i>plus</i> -IM	6
Section 2: Description of SBE 16<i>plus</i>-IM.....	7
System Description	7
Specifications	9
Dimensions and End Cap Connectors	11
Data Storage	12
Batteries	12
Battery Endurance	13
Configuration Options and Plumbing	14
Surface Inductive Modem (SIM)	16
Mooring Cable and Wiring Requirements	17
Section 3: Preparing for Deployment.....	18
Software Installation	18
Power and Communications Test and Setting SBE 16 <i>plus</i> -IM IDs	19
Test Setup	19
Test and Set SBE 16 <i>plus</i> -IM ID	20
Section 4: Deploying and Operating SBE 16<i>plus</i>-IM.....	24
Operation Description	25
Timeout Descriptions	25
Sampling Modes	26
Polled Sampling	26
Autonomous Sampling (logging)	27
Combo Sampling	28
Pump Operation	29
Pump Setting Recommendations	30
Command Descriptions	31
SIM Commands	32
SBE 16 <i>plus</i> -IM Communication Microcontroller Commands	33
SBE 16 <i>plus</i> -IM Acquisition Microcontroller Commands	34
Data Output Formats	46
#iOutputFormat=0 (raw frequencies and voltages in Hex)	46
#iOutputFormat=1 (engineering units in Hex)	48
#iOutputFormat=2 (raw frequencies and voltages in decimal)	49
#iOutputFormat=3 (engineering units in decimal)	50
Setup for Deployment	52
Deployment	53
System Installation and Wiring	55
Installing Optional Inductive Cable Coupler (ICC)	55
Recovery	56
Physical Handling	56
Uploading Data	57
Processing Data Using SBE Data Processing	60
Verifying Contents of Configuration (.con) File	60
Editing Raw Data File	61

Section 5: Routine Maintenance and Calibration	62
Corrosion Precautions.....	62
Connector Mating and Maintenance.....	62
Replacing Alkaline Batteries.....	63
Conductivity Cell Maintenance.....	64
Pressure Sensor (optional) Maintenance.....	65
Pump (optional) Maintenance.....	65
Replacing Anti-Foulant Devices (SBE 16 <i>plus</i> , SBE 19 <i>plus</i>).....	66
Sensor Calibration.....	67
Section 6: Troubleshooting	69
Problem 1: Unable to Communicate with SBE 16 <i>plus</i> -IM.....	69
Problem 2: No Data Recorded.....	69
Problem 3: Nonsense or Unreasonable Data.....	70
Problem 4: Program Corrupted.....	70
Glossary	71
Appendix I: Functional Description and Circuitry	72
Sensors.....	72
Sensor Interface.....	72
Real-Time Clock.....	72
Battery Wiring.....	73
Appendix II: Electronics Disassembly/Reassembly	74
Appendix III: Command Summary	75
Appendix IV: SIM Hookup and Configuration	79
Power Connection.....	79
Interface Option Connection (J1, J2, and J4).....	80
I/O Connector Wiring (JP2).....	80
Inductive Mooring Cable Connection (JP4).....	80
Normal Deployed Operation (J5).....	80
Appendix V: AF24173 Anti-Foulant Device	81
Appendix VI: Replacement Parts	85
Index	88

Section 1: Introduction

This section includes contact information, Quick Start procedure, and photos of a standard shipment.

About this Manual

This manual is to be used with the SBE 16*plus*-IM SEACAT Conductivity and Temperature (pressure optional) Recorder with Inductive Modem.

It is organized to guide the user from installation through operation and data collection. We have included detailed specifications, command descriptions, maintenance and calibration information, and helpful notes throughout the manual.

Sea-Bird welcomes suggestions for new features and enhancements of our products and/or documentation. Please e-mail any comments or suggestions to seabird@seabird.com.

How to Contact Sea-Bird

Sea-Bird Electronics, Inc.
1808 136th Place Northeast
Bellevue, Washington 98005 USA

Telephone: 425-643-9866 Fax: 425-643-9954
E-mail: seabird@seabird.com Website: <http://www.seabird.com>

Business hours:
Monday-Friday, 0800 to 1700 Pacific Standard Time
(1600 to 0100 Universal Time)
Except from April to October, when we are on *summer time*
(1500 to 0000 Universal Time)

Quick Start

Follow these steps to get a Quick Start using the SBE 16*plus*-IM. The manual provides step-by-step details for performing each task:

1. Perform pre-check (*Section 3: Preparing for Deployment*):
 - A. Test power and communications.
 - B. Set 16*plus*-IM ID.
2. Deploy (*Section 4: Deploying and Operating SBE 16plus-IM*):
 - A. Install new batteries if necessary.
 - B. Ensure all data has been uploaded, and then send **#iiInitLogging** to make entire memory available for recording if desired.
 - C. Set date and then time and establish setup and logging parameters.
 - D. Deploying multiple 16*plus*-IMs: verify set to Prompt ID.
 - E. Set 16*plus*-IM to start logging now or in the future.
 - F. Remove protective plugs from anti-foulant device cups, and verify AF24173 Anti-Foulant Devices are installed. Leave protective plugs off for deployment.
 - G. Install dummy plugs and/or cable connectors, and locking sleeves.
 - H. Install 16*plus*-IM on mooring cable.
 - I. Install Inductive Cable Coupler (optional) on mooring cable.
 - J. Wire system.

Unpacking SBE 16plus-IM

Shown below is a typical SBE 16plus-IM shipment.



SBE 16plus-IM



Spare o-ring and hardware kit



Conductivity cell filling and storage kit



Conductivity cell cleaning solution (Triton-X)



SBE 16plus-IM manual



Software, and Electronic Copies of Software Manuals and User Manual

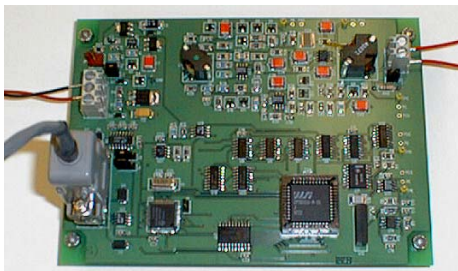

Surface Inductive Modem (SIM) PCB
(one per mooring, optional)



I/O Cable
(included with SIM)



25-pin to 9-pin adapter
(for use with computer with DB-25 connector – included with SIM I/O cable)

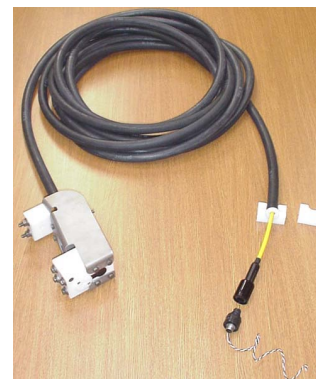

Inductive Cable Coupler (ICC)
(optional with SIM, one per mooring)

Section 2: Description of SBE 16*plus*-IM

This section describes the functions and features of the SBE 16*plus*-IM SEACAT, including:

- system description
- specifications
- dimensions and end cap connectors
- data storage
- batteries and battery endurance
- configuration options and plumbing
- Surface Inductive Modem (SIM), Inductive Cable Coupler (ICC), and mooring requirements

System Description

Note:

For detailed information on inductive modem systems, see *Real-Time Oceanography with Inductive Moorings*, at www.seabird.com under Technical Papers.

The SBE 16*plus*-IM SEACAT is designed to measure conductivity, temperature, and (optional) pressure in marine or fresh-water environments in moored application at depths up to 10,500 meters (34,400 feet). The 16*plus*-IM has internal batteries and non-volatile memory. It uses an Inductive Modem (IM) to transmit data and receive commands over a plastic-jacketed steel mooring cable (or other insulated conductor), using differential-phase-shift-keyed (DPSK) telemetry. No electrical cables or connectors are required. The 16*plus*-IM's built-in inductive coupler (split toroid) and cable clamp provide easy and secure attachment to the mooring cable.

Note:

Half-duplex communication is **one-direction** at a time (i.e., you cannot send commands and receive data at the same time). For example, if the SIM commands a 16*plus*-IM to upload data, nothing else can be done while the data is being sent – the data upload cannot be stopped, and commands cannot be sent to other 16*plus*-IMs on the line.

Communicating with one or more 16*plus*-IMs requires the use of a Sea-Bird Surface Inductive Modem (SIM). The SIM provides a standard serial interface between the user's computer or other controlling device and up to 100 16*plus*-IMs (or other IM-compatible sensors), coupled to a single cable. The user can communicate with the SIM via full-duplex RS-232C or half-duplex RS-485. Commands and data are transmitted half-duplex between the SIM and the 16*plus*-IM.

Commands sent to the 16*plus*-IM provide status display, data acquisition setup, data retrieval, and diagnostic tests. User-selectable operating modes include:

- **Polled sampling** – On command, the 16*plus*-IM takes one sample and transmits data.
- **Autonomous sampling** – At pre-programmed intervals, the 16*plus*-IM wakes up, samples, stores data in its FLASH memory, and powers off.
- **Combo sampling** – Autonomous sampling is in progress, and the 16*plus*-IM can be commanded to transmit the last stored data.

The 16*plus*-IM features the proven Sea-Bird conductivity and temperature sensors. Nine D-size alkaline batteries provide power for approximately 320,000 samples (with no pressure sensor, pump, or auxiliary sensors), depending on the sampling and telemetry schedule. The 8 Mbyte FLASH RAM memory records 1.5 years of conductivity, temperature, and date/time data while sampling every 60 seconds (other configurations/setup vary). User-selectable output format is raw data or engineering units, in hexadecimal or decimal form. Setup, diagnostics, and data extraction are performed without opening the housing. The 16*plus*-IM can power external sensors and acquire their outputs.

A standard 16*plus*-IM is supplied with:

- Plastic housing for depths to 600 meters (1950 feet)
- Bulkhead connectors (Impulse glass-reinforced epoxy):
 - one 2-pin pump connector, and
 - two 6-pin connectors, for two differential auxiliary A/D inputs each
- 8 Mbyte FLASH RAM memory
- 9 D-size alkaline batteries (Duracell MN1300, LR20)
- Anti-foulant device attachments and expendable AF24173 Anti-Foulant Devices. These are attached to each end of the conductivity cell, so that any water that enters the cell is treated.

16*plus*-IM options include:

- Titanium housing for use to 7000 or 10500 meters (22,900 or 34,440 feet)
- Internally mounted pressure sensor -
 - Strain gauge pressure sensor, or
 - Quartz pressure sensor
- Additional bulkhead connector: 4-pin RS-232 connector (for SBE 38 secondary temperature sensor) **or** 3-pin PAR connector
- Pump -
 - SBE 5M (available in plastic or titanium housing) for pumped conductivity, or
 - SBE 5P (plastic housing) or 5T (titanium housing) for pumped conductivity **and** pumped auxiliary sensors
- Sensors for dissolved oxygen, fluorescence, light (PAR), light transmission, and turbidity
- Wet-pluggable (MCBH) connectors in place of standard connectors
- Battery pack kit for lithium batteries for longer deployments (lithium batteries **not** supplied by Sea-Bird).

The 16*plus*-IM is supplied with a powerful Win 2000/XP software package, SEASOFT-Win32, which includes:

- **SEATERM** – terminal program for easy communication and data retrieval.
- **SBE Data Processing** - program for calculation and plotting of conductivity, temperature, pressure, auxiliary sensor data, and derived variables such as salinity and sound velocity.

Notes:

- Help files provide detailed information on the use of SEATERM and SBE Data Processing.
- A separate software manual contains detailed information on the setup and use of SBE Data Processing.

Specifications

	Temperature (°C)	Conductivity (S/m)	Pressure (optional)
Measurement Range	-5 to +35	0 to 9	0 to full scale range: <ul style="list-style-type: none"> • <i>Strain gauge sensor</i>: 20 / 100 / 350 / 600 / 1000 / 2000 / 3500 / 7000 meters • <i>Quartz sensor</i>: 20 / 60 / 130 / 200 / 270 / 680 / 1400 / 2000 / 4200 / 7000 / 10500 meters
Initial Accuracy	0.005	0.0005	<ul style="list-style-type: none"> • <i>Strain gauge sensor</i>: 0.1% of full scale range • <i>Quartz sensor</i>: 0.02% of full scale range
Typical Stability	0.0002/month	0.0003/month	<ul style="list-style-type: none"> • <i>Strain gauge sensor</i>: 0.05% of full scale range/year • <i>Quartz sensor</i>: 0.025% of full scale range/year
Resolution	0.0001	<ul style="list-style-type: none"> • 0.00005 (most oceanic water; resolves 0.4 ppm in salinity). • 0.00007 (high salinity water; resolves 0.4 ppm in salinity). • 0.00001 (fresh water; resolves 0.1 ppm in salinity). 	<ul style="list-style-type: none"> • <i>Strain gauge sensor</i>: 0.002% of full scale range • <i>Quartz sensor</i>: Depends on sample integration time; consult factory
Sensor Calibration (measurement outside these ranges may be at slightly reduced accuracy due to extrapolation errors)	+1 to +32	0 to 9; physical calibration over the range 2.6 to 6 S/m, plus zero conductivity (air)	Ambient pressure to full scale range in 5 steps
Memory	8 Mbyte non-volatile FLASH memory		
Data Storage	Recorded Parameter		Bytes/sample
	temperature + conductivity		6 (3 each)
	strain gauge pressure		5
	Quartz pressure with temperature compensation		5
	each external voltage		2
	SBE 38 secondary temperature		3
	date and time		4
Real-Time Clock	32,768 Hz TCXO accurate to ±1 minute/year.		

Internal Batteries	Nine alkaline D-cells (Duracell MN 1300, LR20; nominal capacity 14 amp-hours).
Power Requirements	<p> <i>Sampling:</i> no pressure sensor 50 mA with pressure sensor 65 mA <i>Optional Pump:</i> SBE 5M 100 mA SBE 5P or 5T 150 mA <i>Communications:</i> 5 mA <i>Quiescent:</i> 135 μA </p> <p> Sampling time: <ul style="list-style-type: none"> • Minimum 2.2 seconds/sample (no pump, no pressure sensor, 1 measurement/sample, and no delays). • Add 0.3 seconds with strain gauge pressure sensor. • Do not add any time with Quartz pressure sensor, but note that #iiNCycles must be an even number with Quartz pressure sensor (2, 4, 6, etc.). • Add 0.25 seconds for each additional measurement/sample (#iiNCycles \geq 2). • Add pump on-time (0.5 second) if pump running before taking sample (#iiMooredPumpMode=1). • Add time for user-programmed delay before sampling (#iiDelayBeforeSampling=). </p> <p> Approximate Battery Endurance ¹: CT only: 320,000 samples CTD only: 210,000 samples CTD & 5M pump: 120,000 samples ¹ With Duracell MN 1300 (LR20) cells. Dependent on sampling and telemetry scheme; see <i>Battery Endurance</i> for example calculations. </p>
Auxiliary Voltage Sensors	<i>Auxiliary power out:</i> up to 500 mA at 10.5 - 11 VDC <i>A/D resolution:</i> 14 bits <i>Input range:</i> 0 - 5 VDC
Housing Depth Range and Materials	600 meter (1950 ft): acetal copolymer (plastic) 7000 meter (22,900 ft): 3AL-2.5V titanium 10,500 meter (34,400 ft): 6AL-4V titanium
Weight (without pump)	With plastic housing: <i>in air</i> - 9 kg (20 lbs) <i>in water</i> - 4 kg (9 lbs) With 3AL-2.5V titanium housing: <i>in air</i> - 17 kg (38 lbs) <i>in water</i> - 12 kg (27 lbs)

Dimensions and End Cap Connectors

Dimensions in millimeters (inches)

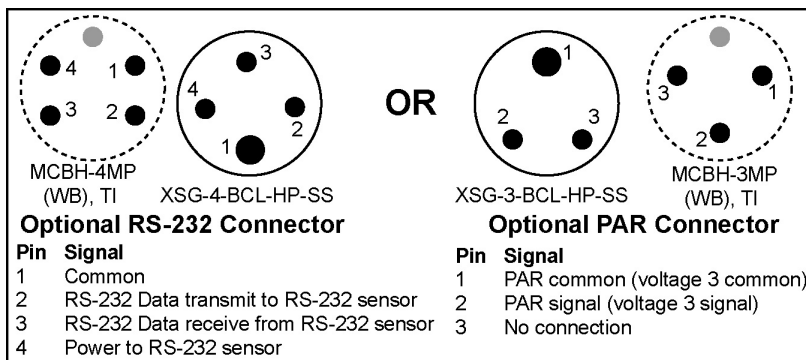
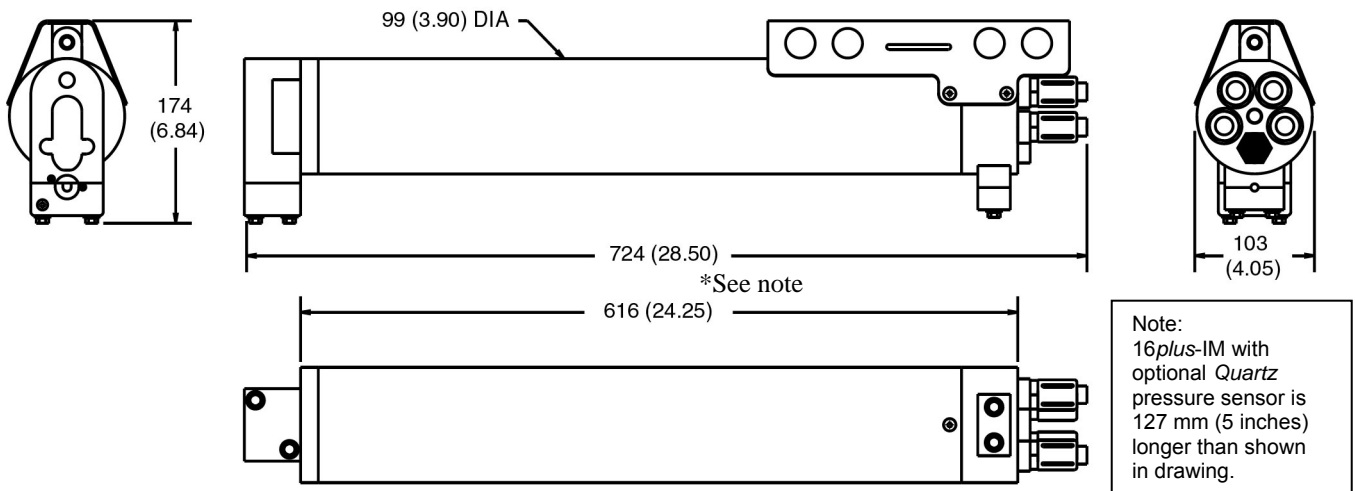

○ = standard connector
 ○ (dashed) = optional MCBH connector (all with 3/8" length base, 1/2-20 thread)

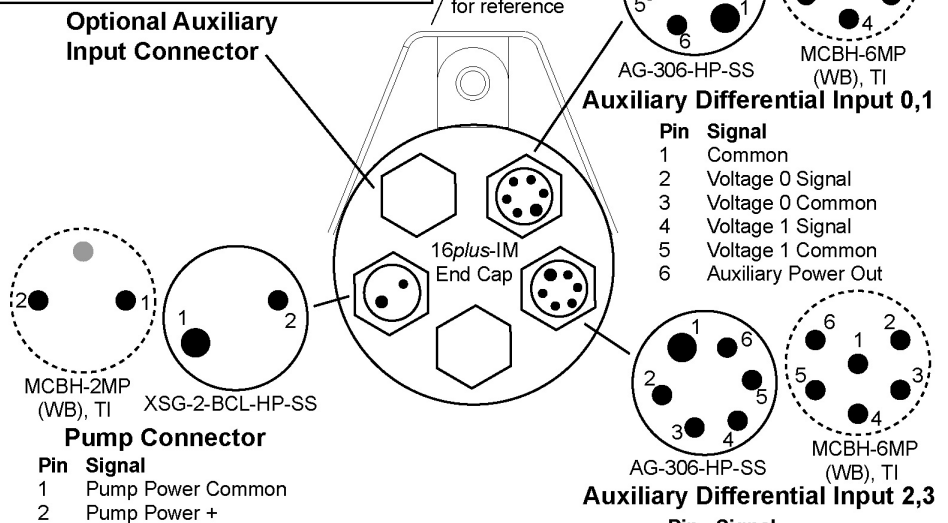

* Not connected if log amp installed for PAR sensor

Data Storage

Note:
See *Battery Endurance* for power limitations.

The SBE 16plus-IM has an 8 Mbyte memory. Shown below are examples of available data storage for several configurations. See *Specifications* for storage space required for each parameter.

Example 1: strain gauge pressure and no auxiliary sensors
T & C = 6 bytes/sample
Strain gauge P = 5 bytes/sample
Date/Time = 4 bytes/sample
Storage space $\approx 8,000,000 / (6 + 5 + 4) \approx 533,000$ samples

Example 2: Quartz pressure, 4 external voltages, and SBE 38 secondary temperature sensor
T & C = 6 bytes/sample
Quartz P = 5 bytes/sample
External voltages = 2 bytes/sample * 4 voltages = 8 bytes/sample
SBE 38 = 3 bytes/sample
Date/Time = 4 bytes/sample
Storage space $\approx 8,000,000 / (6 + 5 + 8 + 3 + 4) \approx 307,000$ samples

Batteries

For the main battery, the SBE 16plus-IM uses nine D-cell alkaline batteries (Duracell MN 1300, LR20). If necessary, lithium, carbon-zinc, or mercury cells can also be used.

On-board lithium batteries (non-hazardous units which are unrestricted for shipping purposes) are provided to back-up the buffer and the real-time clock in the event of main battery failure or exhaustion. The main batteries may be replaced without affecting either the real-time clock or memory.

Battery Endurance

Notes:

- If the 16plus-IM is logging data and the battery voltage is less than 7.5 volts, the 16plus-IM halts logging and displays a low battery indication in the data.
- See *Data Storage and Specifications* for data storage limitations.

The standard alkaline battery pack has a nominal capacity of 14 amp-hours. For planning purposes, Sea-Bird recommends using a conservative value of:

- 12.2 amp-hours for an SBE 16plus-IM with no pump or auxiliary sensors
- 10.5 amp-hours for an SBE 16plus-IM drawing more current because of optional pump and/or auxiliary sensors

Current consumption and sampling times vary greatly, depending on the instrument configuration (inclusion of pressure sensor, pump, and/or auxiliary sensors) as well as user-programmed sampling parameters (pump operating mode, number of measurements per sample, delay before sampling). Examples are shown below for several sampling schemes.

- Assuming the fastest practical interrogation scheme (wake all 16plus-IMs on mooring, send **GData**, send **Dataii** to each 16plus-IM, and power off all 16plus-IMs), the communications current is drawn for approximately 0.5 seconds **per 16plus-IM on the mooring**. Each 16plus-IM on the mooring draws this current while any 16plus-IM is being queried to transmit data. Other interrogation schemes require more time.

Ten 16plus-IMs with standard alkaline batteries are set up to sample autonomously every 10 minutes (6 samples/hour), and the last data sample will be requested by the computer every hour. How long can the instruments be deployed?

Example 1 – no pump, pressure sensor, or auxiliary sensors; 1 measurement/sample (#iiNCycles=1):

Sampling current = 50 mA * 2.2 sec = 0.11 amp-sec/sample

In 1 hour, sampling current = 6 samples * 0.11 amp-sec/sample = 0.66 amp-sec/hour

Quiescent current = 135 microamps = 0.135 mA

In 1 hour, quiescent current ≈ 0.135 mA * 3600 sec/hour = 0.49 amp-sec/hour

Communication current / query = 5 mA * 0.5 sec / 16plus-IM to be queried * 10 instruments = 0.025 amp-sec/hour

Current consumption / hour = 0.66 + 0.49 + 0.025 = 1.175 amp-sec/hour

Capacity = (12.2 amp-hours * 3600 sec/hr) / (1.175 amp-sec/hour) = 37379 hours = 1557 days = 4.3 years

However, Sea-Bird recommends that batteries should not be expected to last longer than 2 years in the field.

Example 2 - with 5M pump on for 0.5 sec/sample (#iiMooredPumpMode=1), no pressure sensor or auxiliary sensors, 1 measurement/sample (#iiNCycles=1):

Sampling current = 50 mA * (2.2 sec + 0.5 sec) = 0.135 amp-sec/sample

In 1 hour, sampling current = 6 * 0.135 amp-sec/sample = 0.81 amp-sec/hour

Pump current = 100 mA * 0.5 sec = 0.05 amp-seconds/sample

In 1 hour, pump current = 6 * 0.05 amp-sec/sample = 0.3 amp-sec/hour

Quiescent current = 135 microamps = 0.135 mA

In 1 hour, quiescent current ≈ 0.135 mA * 3600 sec/hour = 0.49 amp-sec/hour

Communication current / query = 5 mA * 0.5 sec / 16plus-IM to be queried * 10 instruments = 0.025 amp-sec/hour

Current consumption / hour = 0.81 + 0.3 + 0.49 + 0.025 = 1.62 amp-sec/hour

Capacity = (10.5 amp-hours * 3600 seconds/hr) / (1.62 amp-seconds/hour) = 23333 hours = 972 days = 2.6 years

However, Sea-Bird recommends that batteries should not be expected to last longer than 2 years in the field.

Example 3 – with 5T pump on during sample (#iiMooredPumpMode=2), Quartz pressure sensor, 15 sec delay before sampling (#iiDelayBeforeSampling=15), auxiliary sensors drawing 100 mA, 4 measurements/sample (#iiNCycles=4):

On-time = 2.2 + 15 (delay before sampling) + (4 – 1) * 0.25 (additional measurements/sample) = 17.95 sec

Sampling current = 65 mA * 17.95 sec = 1.167 amp-sec/sample

In 1 hour, sampling current = 6 * 1.167 amp-sec/sample = 7.0 amp-sec/hour

5T Pump current = 150 mA * 17.95 sec = 2.69 amp-sec/sample

In 1 hour, pump current = 6 * 2.69 amp-sec/sample = 16.2 amp-sec/hour

Auxiliary sensor current = 100 mA * 17.95 sec = 1.80 amp-sec/sample

In 1 hour, auxiliary sensor current = 6 * 1.80 amp-sec/sample = 10.8 amp-sec/hour

Quiescent current = 135 microamps = 0.135 mA

In 1 hour, quiescent current ≈ 0.135 mA * 3600 sec/hour = 0.49 amp-sec/hour

Communication current / query = 5 mA * 0.5 sec / 16plus-IM to be queried * 10 instruments = 0.025 amp-sec/hour

Current consumption / hour = 7.0 + 16.2 + 10.8 + 0.49 + 0.025 = 34.5 amp-sec/hour

Capacity = (10.5 amp-hours * 3600 sec/hr) / (34.5 amp-sec/hour) = 1095 hours = 45 days = 0.12 years

Configuration Options and Plumbing

The SBE 16*plus*-IM is available with an optional, externally mounted, submersible pump. The pump is required for a 16*plus*-IM configured with an optional dissolved oxygen sensor or pumped fluorometer, but also provides the following benefits for conductivity data:

- Improved conductivity response - The pump flushes the previously sampled water from the conductivity cell and brings a new water sample quickly into the cell.
- Improved anti-foulant protection - Water does not freely flow through the conductivity cell between samples, allowing the anti-foulant concentration inside the cell to build up.

Several pump models are available:

- SBE 5M miniature pump (available in plastic or titanium) - for pumped conductivity
- SBE 5P (plastic) or 5T (titanium) pump - a more powerful pump for use if the 16*plus*-IM is configured with a dissolved oxygen sensor and/or pumped fluorometer

In all cases, the pump is powered via a cable connected to the standard 2-pin Pump bulkhead connector on the sensor end cap.

The 16*plus*-IM can be configured with a wide range of auxiliary sensors. Two standard 6-pin bulkhead connectors on the sensor end cap serve as the input ports for the auxiliary sensor signal voltages and provide power to the sensors. Additionally, an optional connector can be provided for interfacing with a secondary temperature sensor - an SBE 38 (RS-232 communications), or an optional connector can be provided for interfacing with a PAR sensor.

Shown below is the plumbing arrangement of a 16plus-IM equipped with a pump and the optional SBE 43 Dissolved Oxygen sensor. See *Section 4: Deploying and Operating SBE 16plus-IM* for pump setup and operation details.

- Main plumbing is 13 mm ID x 19 mm OD (1/2 inch x 3/4 inch) Tygon tubing.
- A 13 mm (0.5 inch) long piece of 9.5 mm ID x 13 mm OD (3/8 inch x 1/2 inch) Tygon tubing to fit to the main plumbing is installed:
 - on the conductivity cell exhaust, and
 - on the SBE 43 intake and exhaust

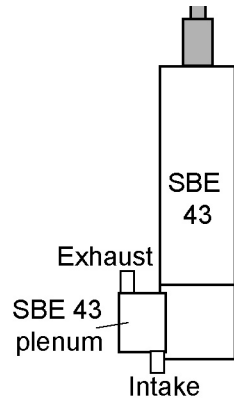

Place DO sensor with plenum intake closer than exhaust to SBE 43 housing, as shown.
 Note: SBE 43 housing orientation (connector end up or down) does not affect operation. Plenum can be reversed on housing by removing and replacing 2 screws.

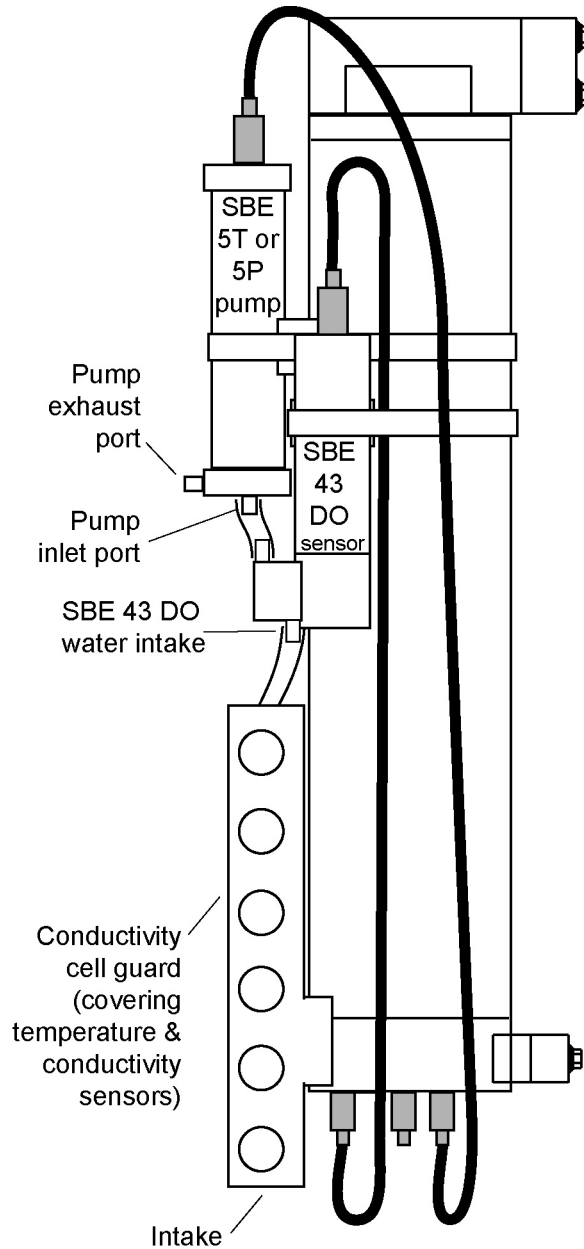

Surface Inductive Modem (SIM)

A Sea-Bird Surface Inductive Modem (SIM) PCB is required for communication with the SBE 16*plus*-IM. The SIM must be supplied with 7 to 25 volts DC power. The operating current is approximately 30 milliamps.

The user's computer or buoy controller is interfaced via RS-232 (optional RS-485) serial port to the SIM. The standard interface protocol between the computer/controller and SIM is 1200, 2400, 4800, or 9600 baud (user-selectable); 8 data bits; no parity; RS-232C; with echoing of characters.

The SIM impresses (*modulates*) the mooring cable with a DPSK signal that is encoded with the commands received from the computer/controller. The encoded signals are *demodulated* by 16*plus*-IMs coupled to the cable. Replies from 16*plus*-IMs are similarly coupled to the cable and *demodulated* by the SIM.

The DPSK communication link between the SIM and 16*plus*-IM(s) is half-duplex, so talking and listening is sequential only. Although the data link between the SIM and the user's computer/controller is established at 1200, 2400, 4800, or 9600 baud, the DPSK modem communication between SIM and 16*plus*-IMs always operates at 1200 baud.

Mooring Cable and Wiring Requirements

Note:

See *Appendix IV: SIM Hookup and Configuration* for wiring details.

The SBE 16plus-IM can mechanically accommodate mooring cables up to 16 mm (0.63 inches) in diameter. Clamps for specific cable diameters are available, or can be supplied on a custom basis. Suitable mooring cables use steel wire rope with a polypropylene or polyethylene-insulating jacket. The SIM operates without data errors using up to 10,500 meters (34,400 feet) of 3 mm (0.12 inches) or larger cable.

The mooring cable must provide for connection to seawater ground below the deepest 16plus-IM. Terminating the wire with a metallic eye or clevis readily provides this connection.

The mooring cable must also provide for connection to the SIM.

- In a direct connection (typical cable-to-shore applications), the bottom end of the wire is grounded to seawater, and the top end remains insulated to the connection to the SIM. A second wire from the SIM connects to seawater ground, completing the circuit.
- In typical surface buoys it is often preferable to connect the jacketed mooring wire to the buoy with a length of chain, grounding the jacketed wire to seawater at each end. An Inductive Cable Coupler (ICC) connects the SIM to the jacketed wire above the uppermost 16plus-IM and below the point where the wire is grounded.

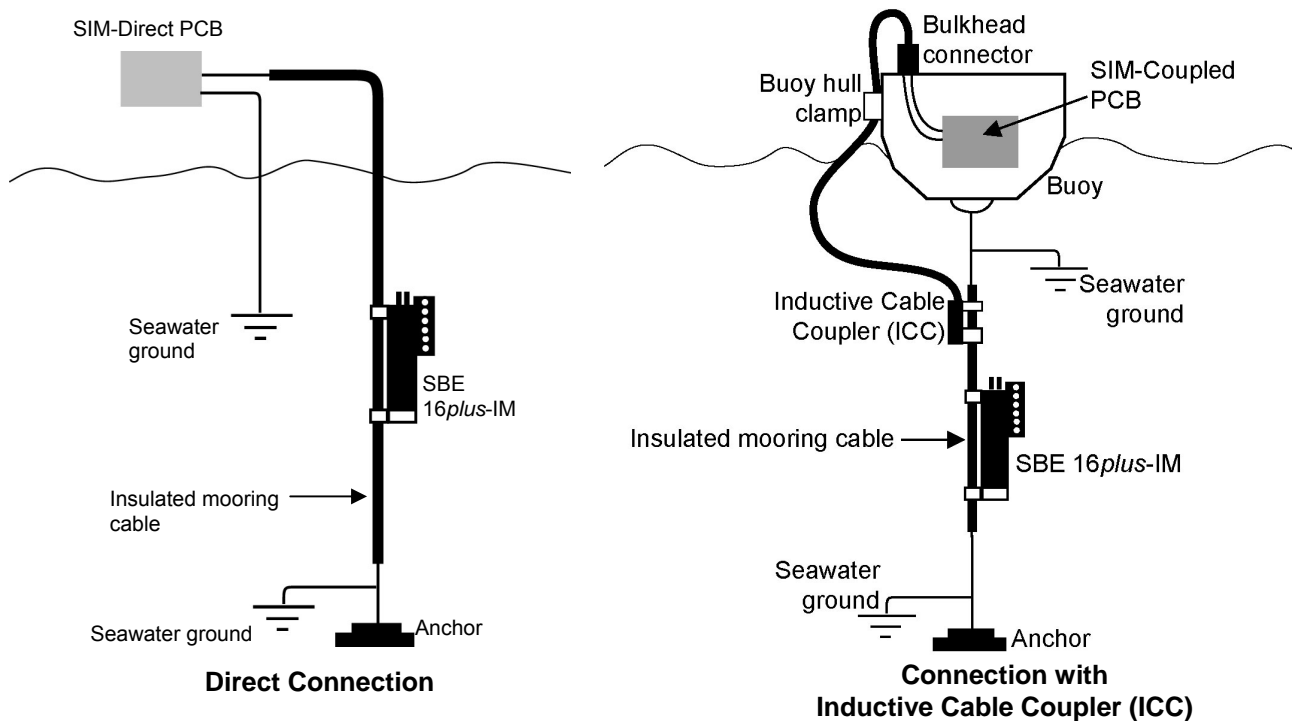

Section 3: Preparing for Deployment

This section describes:

- Installation and use of SEATERM terminal program
- Power and communications test to verify that the system works prior to deployment
- Setting SBE 16*plus*-IM ID - each 16*plus*-IM on a mooring must have a unique ID for communicating with the SIM and computer/controller

Software Installation

Sea-Bird recommends the following minimum system requirements for SEASOFT-Win32: Windows 2000 or later, 500 MHz processor, 256 MB RAM, and 90 MB free disk space for installation.

Note:

It is possible to use the 16*plus*-IM without SEATERM by sending direct commands from a dumb terminal or terminal emulator, such as Windows HyperTerminal.

If not already installed, install SEATERM and other Sea-Bird software programs on your computer using the supplied software CD:

1. Insert the CD in your CD drive.
2. Double click on **Seasoft-Win32.exe**.
3. Follow the dialog box directions to install the software.

The default location for the software is c:/Program Files/Sea-Bird. Within that folder is a sub-directory for each program. The installation program allows you to install the desired components. Install all the components, or just install SEATERM (terminal program) and SBE Data Processing.

Power and Communications Test and Setting SBE 16*plus*-IM IDs

The power and communications test will verify that the system works, prior to deployment.

Note:

For testing and setup, an ICC is not required, even if using SIM-Coupled.

Note:

Important! For Normal Deployed operation, reinstall the jumper across J5.

Test Setup

1. Loop insulated wire through the 16*plus*-IM modem coupling core to simulate a mooring cable. Connect the test wire ends to the SIM's mooring cable terminals (JP4). (See *Appendix IV: SIM Hookup and Configuration* for detailed information.)
2. On the SIM, remove the jumper on J5 (see *Appendix IV*). This inserts a 1K resistor in series with the inductive loop and reduces signal amplitude, preventing 16*plus*-IMs that are near but not attached to the inductive loop from responding to commands (especially important when sending the ***ID=** command).
3. Connect the SIM to a 7-25 VDC power supply. Approximately 30 milliamps are required. **Do not turn on the power supply yet.**
4. Connect the SIM to your computer's serial port using the 9-pin to 9-pin cable supplied with the SIM.

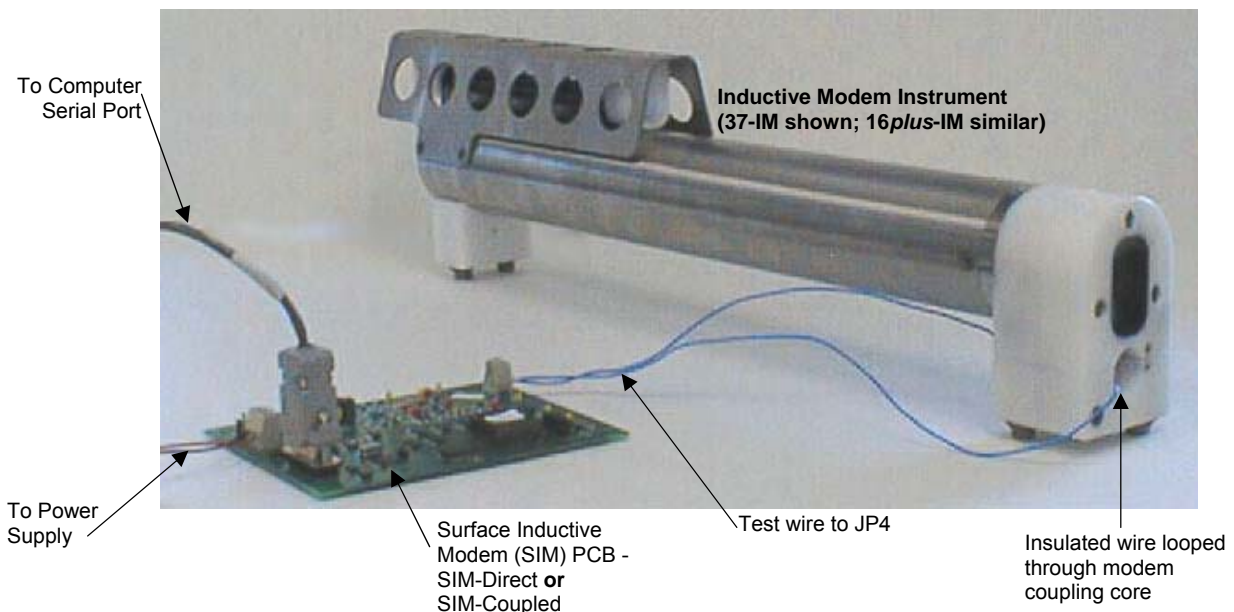

Test and Set SBE 16plus-IM ID

Proceed as follows:

Note:
See SEATERM's Help files.

1. Double click on SeaTerm.exe. If this is the first time the program is used, the setup dialog box may appear:

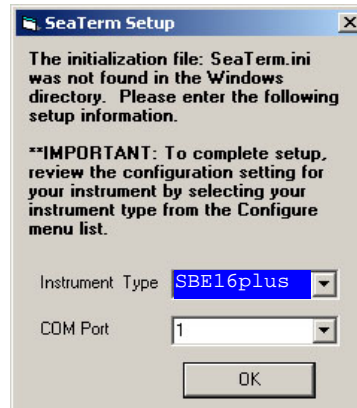

Select the instrument type (*SBE 16plus*) and the computer COM port for communication with the 16plus-IM. Click OK.

2. The main screen looks like this:

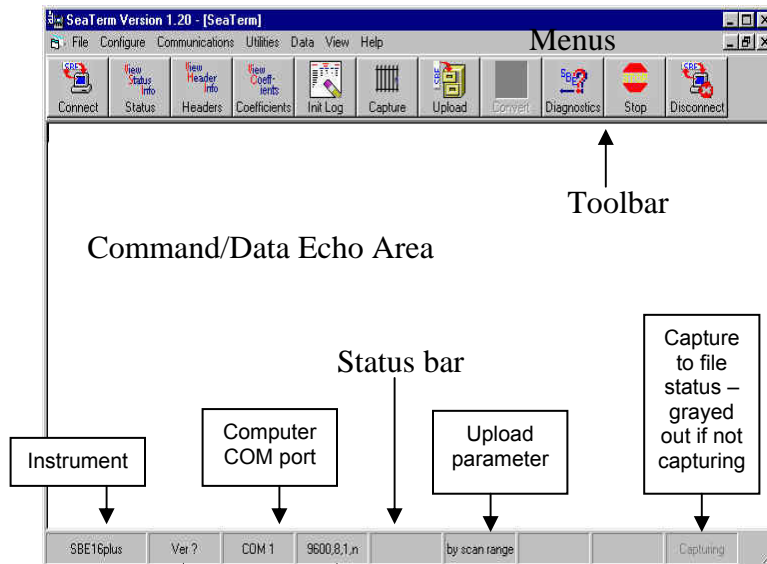

Note:
There is at least one way, and as many as three ways, to enter a command:

- Manually type a command in Command/Data Echo Area
- Use a menu to automatically generate a command
- Use a Toolbar button to automatically generate a command

Note:
Once the system is configured and connected (Steps 3 through 5 below), to update the Status bar:

- on the Toolbar, click Status; or
- from the Utilities menu, select Instrument Status.

SEATERM sends the status command, which displays in the Command/Data Echo Area, and updates the Status bar.

- Menu – Contains tasks and frequently executed instrument commands.
- Toolbar – Contains buttons for frequently executed tasks and instrument commands. All tasks and commands accessed through the Toolbar are also available in the Menu. To display or hide the Toolbar, select View Toolbar in the View menu. Grayed out Toolbar buttons are not applicable.
- Command/Data Echo Area – Echoes a command executed using a Menu or Toolbar button, as well as the instrument's response. Additionally, a command can be manually typed in this area, from the available commands for the instrument. Note that the instrument must be *awake* for it to respond to a command (use Connect on the Toolbar to wake up the instrument).
- Status bar – Provides status information. To display or hide the Status bar, select View Status bar in the View menu.

Following are the Toolbar buttons applicable to the 16plus-IM:

Toolbar Buttons	Description	Equivalent Command*
Connect	Re-establish communications by sending wakeup tone to all 16plus-IMs. Computer responds with S> prompt. 16plus-IM communication microcontrollers <i>go to sleep</i> after 2 minutes without communication from computer have elapsed.	PwrOn
Status	Display instrument setup and status (logging, number of samples in memory, etc.).	#iiDS
Headers	View data headers (header number, date and time, first and last sample, and sample interval). A new header is generated at the start of logging and every subsequent 1000 scans.	#iiDH
Coefficients	Display calibration coefficients.	#iiDCal
Init Log	Reset data pointers and header numbers. This should be performed after existing data has been uploaded from 16plus-IM and prior to recording new data.	#iiInitLogging
Capture	Capture instrument responses on screen to file; may be useful for diagnostics. File has .cap extension. Press Capture again to turn off capture. Capture status displays in Status bar.	—
Upload	Upload data stored in memory, in format Sea-Bird's data processing software can use (raw hex). Uploaded data has .hex extension. Before using Upload: <ul style="list-style-type: none"> • Configure upload and header parameters in Configure menu • Stop logging by sending #iiStop. 	#iiDDb,e (use Upload button if you will be processing data with SBE Data Processing)
Diagnostics	Perform one or more diagnostic tests on 16plus-IM. Diagnostic test(s) accessed in this manner are non-destructive – they do not write over any existing instrument settings.	#iiDS, #iiDCal, and #iiTS
Stop	—	Not applicable to 16plus-IM
Disconnect	Free computer COM port used to communicate with 16plus-IM. COM port can then be used by another program.	—

*See *Command Descriptions* in Section 4: *Deploying and Operating SBE 16plus-IM*.

3. In the Configure menu, select *SBE 16plus*. The dialog box looks like this:

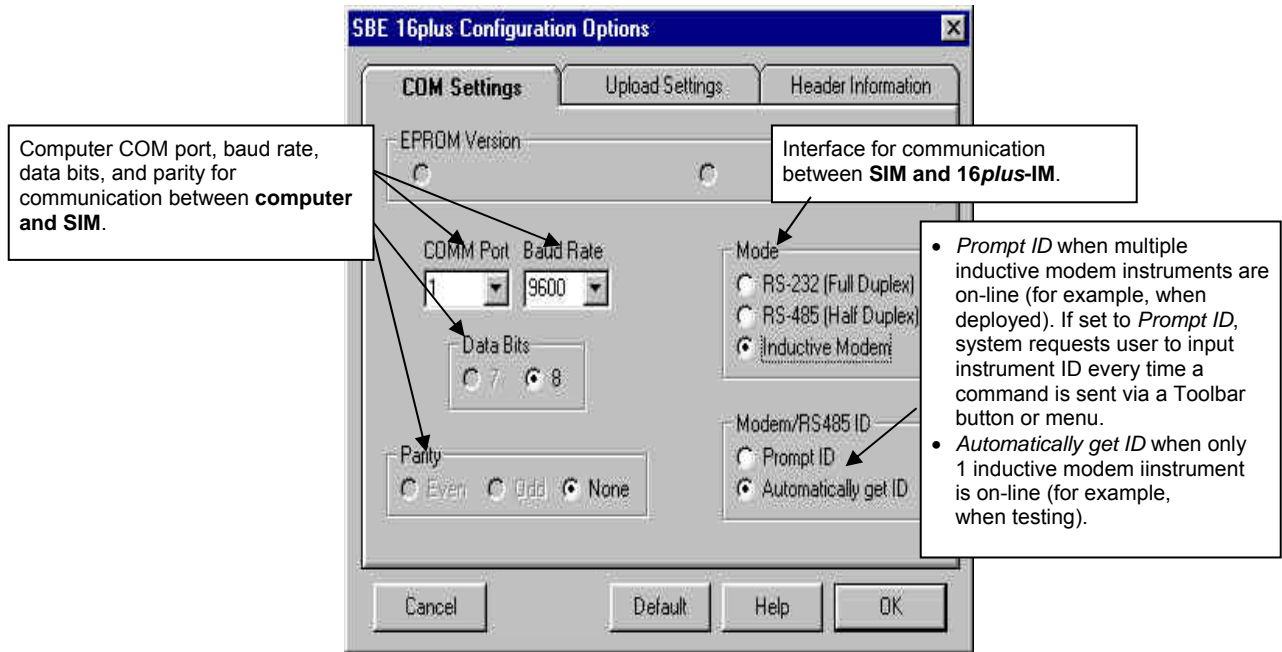
**Notes:**

- SEATERM's baud rate must be the same as the SIM baud rate (set with **Baud=**). Baud is factory-set to 9600, but can be changed by the user (see *Command Descriptions* in *Section 4: Deploying and Operating SBE 16plus-IM*).
- When you click OK, SEATERM saves the Configuration Options settings to the SeaTerm.ini file in your Windows directory. SeaTerm.ini contains the last saved settings for each instrument (*16plus*, *37*, etc.). When you open SEATERM and select the desired instrument in the Configure menu, the Configuration Options dialog box shows the last saved settings for that instrument.
- When deploying on a mooring cable with multiple inductive instruments, change *Modem/RS485 ID* to *Prompt ID* after testing is complete.

Note:

The display shows *SBE 37* because the SIM was originally developed for the *SBE 37-IM MicroCAT*.

Make the selections in the Configuration Options dialog box:

- **COMM Port:** COM 1 through COM 10, as applicable
- **Baud Rate:** 1200, 2400, 4800, or 9600, as applicable (see Configuration Sheet in manual)
- **Data Bits:** 8
- **Parity:** None
- **Mode:** Inductive Modem
- **Modem/RS485 ID:** Automatically get ID

Click OK to save the settings.

4. Turn on the SIM power supply (if already on, turn it off and then on again). The display looks like this:

```
SBE 37 SURFACE MODEM V 2.8a
S>
Sending wake up tone, wait 4 seconds
S>
```

This shows that correct communications between the computer and SIM have been established, and the SIM has sent the wake-up signal to the *16plus-IM*. If the system does not respond as shown above:

- Click Connect on the Toolbar.
 - Verify the correct instrument was selected in the Configure menu and the settings were entered correctly in the Configuration Options dialog box. Note that the baud rate is documented on the Configuration Sheet.
 - Check cabling between the computer, SIM, and *16plus-IM*.
5. Click Connect on the Toolbar. This allows the system to use the *Automatically get ID* feature when using the Toolbar keys or menus.

6. Confirm the 16*plus*-IM has responded to the wake-up signal by typing **ID?** and pressing the Enter key. The display looks like this:

```
id=01
```

where 01 is the number set at the factory or by the previous user. See the Configuration Sheet for the factory-set identification (ID) number. The ID is stored in the 16*plus*-IM EEPROM and can be changed, so that multiple 16*plus*-IMs on a single mooring each have a unique ID.

Press the Enter key to get the S> prompt.

7. Display 16*plus*-IM status information by clicking Status on the Toolbar or typing **#iIDS** (ii = 16*plus*-IM ID) and pressing the Enter key. The display looks like this:

```
SBE 16plus-IM V 1.2a SERIAL NO. 4000 01 Mar 2006 14:02:13
vbatt = 9.6, vlith = 8.5, ioper = 61.2 ma, ipump = 25.5 ma
status = not logging
sample interval = 15 seconds, number of measurements per sample = 1
samples = 4, free = 559234
run pump for 0.5 sec, delay before sampling = 0.0 seconds
battery cutoff = 7.5 volts
pressure sensor = strain gauge, range = 1000.0
SBE 38=no, Ext Volt 0=no, Ext Volt 1=no, Ext Volt 2=no, Ext Volt 3=no
output format = converted decimal
output sample number = yes, output salinity = no, output sound
velocity = no
```

Note:

Sending the status command causes the optional pump to turn on for a moment, so that the 16*plus*-IM can measure and output the pump current. Because the pump is designed to be water lubricated, you may hear a noise when the impeller spins in air. Running the pump *dry* for **short** periods (for example, when sending the status command) will not harm the pump.

Note:

The SIM and 16*plus*-IM have timeout algorithms designed to:

- restore control to the computer if an illegal command is sent
- conserve battery energy if too much time elapses between commands

If the system does not appear to respond, see *Timeout Descriptions* in Section 4: *Deploying and Operating SBE 16plus-IM*.

8. Command the 16*plus*-IM to take a sample by typing **#iITS** (ii = 16*plus*-IM ID) and pressing the Enter key. The display looks like this (if converted decimal output format, output sample number, no output salinity or sound velocity, and no auxiliary sensors):

```
4000, 23.7658,0.00019, 0.062, 01 Mar 2006, 14:10:10, 5
```

where 4000 = 16*plus*-IM serial number 4000 (16pxxxxx-4000)
 23.7658 = temperature in degrees Celsius
 0.00019 = conductivity in S/m
 0.062 = pressure in db
 01 Mar 2006 = date
 14:10:10 = time
 5 = sample number in memory

These numbers should be reasonable; i.e., room temperature, zero conductivity, barometric pressure (gauge pressure), current date and time (set at factory to Pacific Daylight or Standard Time), expected number of samples in memory.

Press the Enter key to get the S> prompt.

9. Each 16*plus*-IM on a mooring must have a unique ID for communicating with the SIM and computer. Set the ID as described below, first verifying that only one 16*plus*-IM is on-line before you set the ID:

- A. Set the 16*plus*-IM ID by typing ***ID=ii** (ii= user-assigned ID number) and pressing the Enter key.
- B. The computer responds by requesting verification, requiring you to again type ***ID=ii** and press the Enter key.
- C. Record the ID for future reference.
- D. Press the Enter key to get the S> prompt.
- E. Click Connect on the Toolbar. This allows the use of the *Automatically get ID* feature when using Toolbar keys or menus.

10. Command the 16*plus*-IM to go to sleep (quiescent state) by typing **PwrOff** and pressing the Enter key.

The SBE 16*plus*-IM is ready for programming and deployment.

Important! When testing and ID setting is complete for all 16*plus*-IMs, reinstall the J5 jumper on the SIM PCB. The jumper must be installed for Normal Deployed operation.

Note:

If more than one 16*plus*-IM is on-line when you set the ID, all 16*plus*-IMs will be set to the same ID.

Section 4: Deploying and Operating SBE 16*plus*-IM

Note:

Separate software manuals and Help files contain detailed information on installation, setup, and use of Sea-Bird's software.

This section provides instructions for deploying the SBE 16*plus*-IM. It includes discussions of:

- System operation and timeout descriptions
- Sampling modes with example sets of commands
- Pump operation
- Command descriptions
- Data output formats
- Deployment
- System installation and wiring
- Recovery - physical handling and uploading data
- Processing data with SBE Data Processing
- Editing a raw data file

Operation Description

The SBE 16plus-IM internal functions are supervised by two internal microcontrollers. The acquisition microcontroller supervises measurement acquisition, and setup and sampling functions. The communication microcontroller supervises communication between the 16plus-IM and SIM. These two microcontrollers allows for independent control of power usage by the communication and acquisition circuits. Acquisition consumes more power, but for shorter duration. Communication protocols take proportionately more time, but can be controlled separately and operate at lower power, thus maximizing battery life. This also prevents communication protocols from interfering with measurement acquisition timing.

Commands sent to the SIM can be directed to the SIM, the 16plus-IM communication microcontroller, or the 16plus-IM acquisition microcontroller. A command prefix (ID) is used to direct commands to an 16plus-IM with the same ID. Global commands do not require a prefix and are recognized by all 16plus-IMs attached to the same inductive cable.

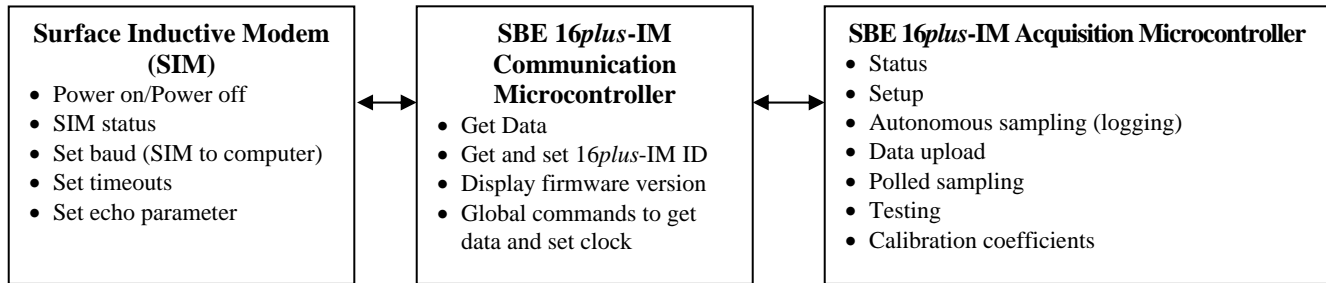

Timeout Descriptions

Both the SIM and the 16plus-IM have timeout algorithms.

SIM Timeouts

SIM timeouts restore control to the computer if no reply is received from the 16plus-IM (for example, upon sending an illegal command) within a specified length of time. This allows new commands to be sent. There are two user-programmable SIM timeouts:

- **DataNNMax** – timeout that applies to the **Dataii** command only. Default is 1000 milliseconds.
- **RelayMax** – timeout that applies to all other commands. Default is 20 seconds.

When using RS-232 between the SIM and computer, control of the SIM can be re-established sooner than the timeout by pressing the Esc key and then the Enter key. When the S> prompt is displayed, new commands can be sent.

SBE 16plus-IM Communications Microcontroller Timeout

If the 16plus-IM does not receive a command for 2 minutes, it powers down its communication circuits to prevent exhaustion of its batteries. **To re-establish control, send PwrOn or click Connect on the Toolbar.**

Sampling Modes

Note:

The 16plus-IM communications microcontroller automatically enters quiescent state after 2 minutes without receiving a command.

The SBE 16plus-IM has three basic sampling modes for obtaining data:

- Polled Sampling
- Autonomous Sampling (logging)
- Combo Sampling

Sampling commands can be used in various combinations to provide a high degree of operating flexibility. Review the operation of the three basic sampling modes and the commands described in *Command Descriptions* before setting up your system.

Descriptions and examples of the sampling modes follow for a system with three 16plus-IMs (IDs 01, 02, and 03) on a mooring cable. Note that the 16plus-IM response to each command is not shown in the examples.

Polled Sampling

On command, the SBE 16plus-IM takes one sample of data and sends the data to the SIM. Storing of data in the 16plus-IM FLASH memory is dependent on the particular command used. Note that it is not possible to synchronize the data samples from each 16plus-IM in polled sampling.

Example: Polled Sampling (user input in bold)

Send wakeup tone to all 16plus-IMs. Globally set date and time to September 1, 2004 at 9 am. For each 16plus-IM: set up with strain gauge pressure sensor and 1 voltage sensor, no pump, take and average 4 measurements for each sample, and output data in converted decimal format. After all parameters are entered, verify setup. Then command each 16plus-IM to take a sample, and send data to SIM (do not store data in 16plus-IM memory). Send power-off command to all 16plus-IMs.

(Click Connect on Toolbar to wake up all 16plus-IMs.)

S>**MMDDYY=090104**

S>**HHMMSS=090000**

S>**#01PTYPE=1**

S>**#01VOLT0=Y**

S>**#01MOORED PUMPMODE=0**

S>**#01NCYCLES=4**

S>**#01OUTPUTFORMAT=3**

S>**#01DS** (to verify setup)

(Repeat **#iiPTYPE=** through **#iiDS** for 16plus-IMs 02 and 03.)

S>**#01TS**

S>**#02TS**

S>**#03TS**

S>**PWROFF**

Autonomous Sampling (logging)

At pre-programmed intervals, the SBE 16plus-IM wakes up, samples data, stores the data in its FLASH memory, and enters quiescent (sleep) state. The 16plus-IM goes to sleep for a minimum of 3 seconds between each sample. The 16plus-IM does not transmit data to the SIM. Autonomous sampling is started with **#iiStartNow** or **#iiStartLater**, and is stopped with **#iiStop**.

To synchronize the data samples for each 16plus-IM in Autonomous Sampling (see *Specifications* in *Section 2: Description of SBE 16plus-IM* for the real-time clock specifications):

- Send a global command to set the date and time for all 16plus-IMs.
- Set the sampling interval for each 16plus-IM to the same value.
- Set the start sampling date and time for each 16plus-IM to the same value.

The 16plus-IM has a *lockout* feature to prevent unintended interference with sampling. If the 16plus-IM is sampling or is waiting to start sampling (**#iiStartLater** has been sent, but logging hasn't started yet), only the following commands will be accepted:

- All SIM commands,
- These 16plus-IM Communication Microcontroller commands:
GData, Dataii, ID?, and !iiDS
- These 16plus-IM Acquisition Microcontroller commands:
#iiDS, #iiDCal, #iiTS, #iiSL, #iiSLT, and #iiStop.

Note:

Use **#iiStop** to:

- stop autonomous sampling
- stop waiting to start autonomous sampling (after **#iiStartLater** has been sent)

Once **#iiStop** is sent, the 16plus-IM accepts all commands again.

Example: Autonomous Sampling (user input in bold)

Send wakeup tone to all 16plus-IMs. Globally set date and time to September 1, 2004 at 9 am. For each 16plus-IM: initialize logging to overwrite previous data in memory, set up with strain gauge pressure sensor and 1 voltage sensor, take a sample every 120 seconds, take and average 4 measurements for each sample, and output data in raw hex format. Set up pump to run for 0.5 seconds before each sample. Set up to start logging on 15 September 2004 at 12:00:00. Send command to start logging at designated date and time. After all parameters are entered, verify setup. Send power-off command to all 16plus-IMs.

(Click Connect on Toolbar to wake up all 16plus-IMs.)

```
S>MMDDYY=090104
S>HHMMSS=090000
S>#01INITLOGGING
S>#01PTYPE=1
S>#01VOLT0=Y
S>#01SAMPLEINTERVAL=120
S>#01NCYCLES=4
S>#01OUTPUTFORMAT=0
S>#01MOOREDUMPMODE=1
S>#01STARTMMDDYY=091504
S>#01STARTHHMMSS=120000
S>#01STARTLATER
S>#01DS (to verify setup)
(Repeat #iiINITLOGGING through #iiDS for 16plus-IMs 02 and 03.)
S>PWROFF
```

Deploy 16plus-IM. Logging starts automatically at designated date and time.

When ready to upload all data to computer, wake up all 16plus-IMs, stop sampling, and upload data:

(Click Connect on Toolbar to wake up all 16plus-IMs.)

```
S>#01STOP
(Click Upload on Toolbar – program leads you through screens to define data to be uploaded and where to store it.)
(Repeat #iiSTOP through Upload for 16plus-IMs 02 and 03.)
S>PWROFF
```

Combo Sampling

Combo Sampling combines Autonomous Sampling with the ability to retrieve the last data sample from each SBE 16plus-IM, to look at data without stopping the sampling. As in Autonomous Sampling, the 16plus-IM wakes up, samples data at pre-programmed intervals, stores the data in its FLASH memory, and powers-off (enters quiescent state). When desired, the user can request the last stored data sample from a particular 16plus-IM. There are two ways to get the last stored sample:

- From a specific 16plus-IM - use **#iSL**.
- From all 16plus-IMs - use **GData**, which is a global command to each 16plus-IM to hold the last data sample in its buffer. Then, send **Data*i*** to each 16plus-IM to transmit the last data sample from its buffer.

Example: Combo Sampling (user input in bold)

Set up all 16plus-IMs as shown above for Autonomous Sampling.

After logging begins, look at data from last sample to check results:

(Click Connect on Toolbar to wake up all 16plus-IMs.)

```
S>#01SL
S>#02SL
S>#03SL
S>PWROFF
```

OR

(Click Connect on Toolbar to wake up all 16plus-IMs.)

```
S>GDATA
S>DATA01
S>DATA02
S>DATA03
S>PWROFF
```

Upload all data as shown above for Autonomous Sampling.

Pump Operation

Do not run the pump dry. The pump is water lubricated; running it without water will damage it. If briefly testing your system in dry conditions, fill the inside of the pump head with water via the pump exhaust port. This will provide enough lubrication to prevent pump damage during brief testing.

Pump operation is governed by two user-programmable parameters:

- **#iiMooredPumpMode=0, 1, or 2**
The 16plus-IM can be set up to operate with no pump (0), with the pump running for 0.5 seconds before each sample (1), or with the pump running during each sample (2).
- **#iiDelayBeforeSampling=**
The 16plus-IM can be set up to delay sampling after turning on external voltage sensors. Some instruments require time to equilibrate or stabilize after power is applied, to provide good quality data.

Note:

Set **RelayMax=** greater than **#iiDelayBeforeSampling=** to prevent the SIM from timing out during polled sampling.

#iiMooredPumpMode= and **#iiDelayBeforeSampling=** interact in the operation of the pump, as shown below. Recommendations for settings are provided on the next page.

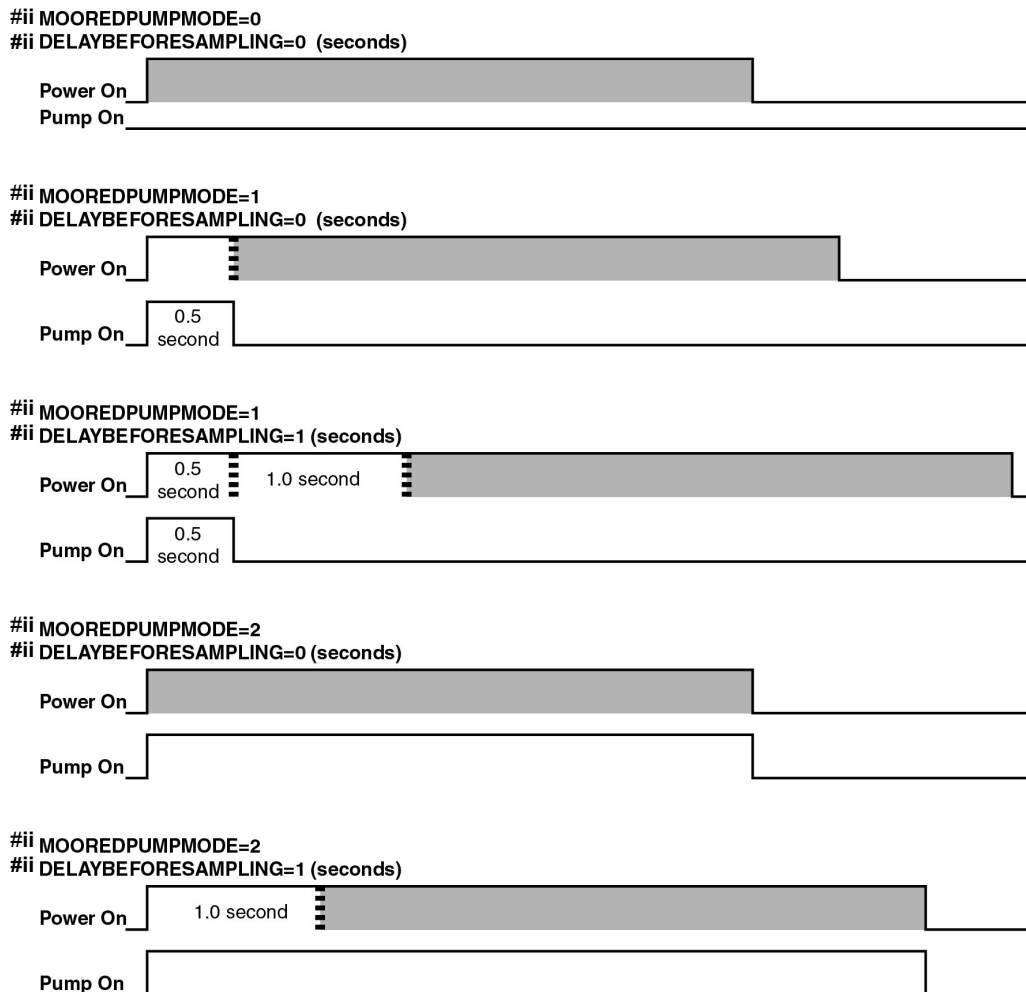

■ = sampling time (≥ 2.2 seconds)

Note:

Sampling time includes time for instrument to warm up as well as time to actually measure parameters. The 2.2 second sampling time is for 16plus-IM with no pressure sensor, and 1 measurement / sample (**#iiNCycles=1**). See *Specifications* in *Section 2: Description of SBE 16plus-IM* for sampling times for other setups.

Pump Setting Recommendations

Sea-Bird provides the following recommendations for pump settings. Note that longer pump times increase power usage, reducing battery endurance. See *Battery Endurance* in *Section 2: Description of SBE 16plus-IM* for sample battery endurance calculations.

Pump through Conductivity Cell Only (SBE 5M, 5P, or 5T pump)

For most deployments, set **#iiMooredPumpMode=1** and **#iiDelayBeforeSampling=0**. The pump operates for 0.5 seconds before the conductivity measurement is made, providing enough time to ventilate the cell and bring in a new sample of water.

If the 16plus-IM is moored in an area with large thermal gradients, it may be necessary to pump for a longer period of time, to eliminate any cell thermal mass effects on the measurement. In this case, set **#iiMooredPumpMode=2** and set **#iiDelayBeforeSampling=** to a non-zero value, providing additional ventilation time (allowing the conductivity cell temperature to equilibrate to the water temperature) before taking the measurement.

Pump through Conductivity Cell and SBE 43 Dissolved Oxygen Sensor (requires SBE 5P or 5T pump)

Set **#iiMooredPumpMode=2**.

As the pump brings new water into the SBE 43 plenum, some time is required for the sensor to equilibrate to the new oxygen level. The time required is dependent on the sensor's membrane thickness, and on the water temperature. Prior to 2007, all SBE 43s were sold with a 0.5 mil thick membrane. Beginning in 2007, Sea-Bird began offering two membrane thicknesses – 0.5 mil (faster response, typically for profiling applications) and 1.0 mil (slower response but more durable, typically for moored applications).

Note:

See *Application Note 64: SBE 43 Dissolved Oxygen Sensor – Background Information, Deployment Recommendations, and Cleaning and Storage* for the response time curves.

- For a **0.5 mil thick** membrane – Recommended **#iiDelayBeforeSampling=** varies in a non-linear fashion, from 15 seconds at 15 °C to 30 seconds at 0 °C.
- For a **1.0 mil thick** membrane – Recommended **#iiDelayBeforeSampling=** varies in a non-linear fashion, from 25 seconds at 15 °C to 40 seconds at 0 °C.

Pump through Conductivity Cell and Beckman- or YSI-type Dissolved Oxygen Sensor (requires SBE 5P or 5T pump)

Set **#iiMooredPumpMode=2**. Set **#iiDelayBeforeSampling=** to 120 to 180 seconds, allowing time for the oxygen sensor to polarize before taking the measurement.

Command Descriptions

This section describes commands and provides sample outputs. See *Appendix III: Command Summary* for a summarized command list.

When entering commands:

- Input commands to the 16plus-IM in upper or lower case letters and register commands by pressing the Enter key.
- The 16plus-IM sends ? CMD if an invalid command is entered.
- If the system does not return an S> prompt after executing a command, press the Enter key to get the S> prompt.
- If a new command is not received within 2 minutes after the completion of a command, the 16plus-IM communications microcontroller returns to the quiescent (sleep) state.
- If in quiescent state, re-establish communications by clicking Connect on the Toolbar or entering **PwrOn** to get an S> prompt.
- The 16plus-IM cannot have samples with different scan lengths (more or fewer data fields per sample) in memory. If the scan length is changed by commanding it to add or subtract a data field (such as an external voltage), the 16plus-IM must initialize logging. Initializing logging sets the sample number and header number to 0, so the entire memory is available for recording data with the new scan length. **Initializing logging should only be performed after all previous data has been uploaded.** Therefore, commands that change the scan length (**#iiPType=**, **#iiVolt0=**, **#iiVolt1=**, **#iiVolt2=**, **#iiVolt3=**, and **#iiSBE38=**) prompt the user for verification before executing, to prevent accidental overwriting of existing data.
- While sampling autonomously, the 16plus-IM responds only to commands that do not change its setup or interfere with sampling (see *Autonomous Sampling* for a list of commands). If you wake up the 16plus-IM while it is sampling (for example, to send **#iiDS** to check on the sampling progress), it will temporarily stop sampling. Sampling will resume when it goes back to sleep again (after the 2-minute timeout).
- While *waiting to start autonomous sampling* (if you sent **#iiStartLater** but sampling has not started yet), the 16plus-IM responds only to commands that do not change its setup or interfere with sampling (see *Autonomous Sampling* for a list of commands). To send any other commands, send **#iiStop**, send the desired commands to modify the setup, and then send **#iiStartLater** again.

Entries made with the commands are permanently stored in the SBE 16plus-IM and remain in effect until you change them.

- The only exception occurs if the electronics are removed from the housing and disconnected from the battery Molex connector (see *Appendix II: Electronics Disassembly/Reassembly*). Upon reassembly, reset the date and time (**MMDDYY=** and **HHMMSS=** or **#iiMMDDYY=** and **#iiHHMMSS=**) and initialize logging (**#iiInitLogging**).

SIM Commands

SIM commands are directed to the Surface Inductive Modem, to set it up for operation with the 16plus-IM.

PwrOn	Send wakeup tone to all 16plus-IMs. Equivalent to Connect on Toolbar.
PwrOff	Send power-off command to all 16plus-IMs. Main power turned off and 16plus-IMs placed in quiescent (sleep) state. Autonomous sampling and memory retention not affected.
DS	Display SIM firmware version and setup. Example includes commands used to modify parameters [in parentheses].

Note:

The **DS** response shows `SBE 37` because the SIM was originally developed for the SBE 37-IM MicroCAT.

Example (user input in bold)

```
S>DS
SBE 37 SURFACE MODEM V 2.8a
wait time for dataNN response = 1000 msec           [DataNNMax=]
wait time for relay command response = 20 seconds   [RelayMax=]
binary relay character timeout = 1000 msec          [not applicable to 16plus-IM]
echo = yes                                          [EchoOn or EchoOff]
execute pwrn command on powerup = yes             [AutoPwrOn=]
```

Note:

The SIM's baud rate (set with **Baud=**) must be the same as SEATERM's baud rate (set in the Configure menu).

Baud=x	x = baud rate between SIM and computer/controller (1200, 2400, 4800, or 9600). Default 9600.
DataNNMax=x	x = timeout (0 – 32767 milliseconds; SIM rounds down to nearest 50 milliseconds) that applies to Dataii only. If no reply is received within DataNNMax , control is returned to computer and other commands can be sent. Default 1000 milliseconds.
RelayMax=x	x = timeout (seconds) that applies to all other commands. If no reply is received within RelayMax (0-3276), control is returned to computer and other commands can be sent. Default 20 seconds.
EchoOn	Echo characters received from computer (default) - computer monitor will show entered commands as you type.
EchoOff	Do not echo characters.
AutoPwrOn=x	x=Y (default): Automatically send PwrOn to 16plus-IMs when power applied to SIM. This wakes up all 16plus-IMs on line. x=N : Do not send PwrOn when power applied to SIM.

Note:

Set **RelayMax=** greater than **#iiDelayBeforeSampling=**. See *Pump Operation*.

Note:

AutoPwrOn=N is not typically used with the 16plus-IM.

SBE 16plus-IM Communication Microcontroller Commands

Note:

The 16plus-IM has a buffer that stores the most recent data sample. Unlike data in the FLASH memory, data in the buffer is erased upon removal or failure of power.

Notes:

- **DDMMYY=** and **MMDDYY=** are equivalent. Either can be used to set the date.
- **Always set both date and then time.** If a new date is entered but not a new time, the new date will not be saved. If a new time is entered without first entering a new date, the date will reset to the last date it was set for with **MMDDYY=** or **DDMMYY=**.
- If the 16plus-IM batteries have been removed, the date and then time must be reset.

Global Commands

GData	Command all 16plus-IM communication microcontrollers to get last data sample from acquisition microcontrollers. 16plus-IM communication microcontrollers hold data in a buffer until receiving Dataii .
MMDDYY=mmddy	Set real-time clock month, day, and year for all 16plus-IMs. Must be followed by HHMMSS= to set time.
DDMMYY=ddmmy	Set real-time clock day, month, and year for all 16plus-IMs. Must be followed by HHMMSS= to set time.
HHMMSS=hmmss	Set real-time clock hour, minute, and second for all 16plus-IMs.

Get Data Command

Dataii	Get data obtained with GData from 16plus-IM with ID = ii (ii = 0-99).
---------------	--

SBE 16plus-IM ID Command

Only one SBE 16plus-IM can be on line when sending these commands.

ID?	Display 16plus-IM ID (ID = ii, where ii= 0-99).
*ID=ii	Set 16plus-IM ID to ii (ii= 0-99). Must be sent twice, because computer requests verification. If more than one 16plus-IM is on-line when sending command, all 16plus-IMs on-line will be set to same ID.

SBE 16plus-IM Communication Microcontroller Firmware Version Command

!iiDS	Display 16plus-IM communication microcontroller firmware version for 16plus-IM with ID=ii.
--------------	--

Example (user input in bold)

```
S> !01DS
SCplus IM V2 1.1a
```

SBE 16plus-IM Acquisition Microcontroller Commands

All 16plus-IM Acquisition Microcontroller commands are preceded by **#ii** (ii= 16plus-IM ID).

Status Command

Notes:

- If configured with a pump, sending **#iiDS** causes the pump to turn on for a moment, so that the 16plus-IM can measure and output the pump current. Because the pump is designed to be water lubricated, you will hear a noise when the impeller spins in air. Running the pump *dry* for such a **short** time will not harm the pump.
- In the example below, no voltage channels are enabled, so external voltage currents (iext01= and iext23=) are not shown.
- If the 16plus-IM is set up with a WET Labs ECO-FL fluorometer with Bio-Wiper (**#iiBiowiper=Y**), the **#iiDS** reply shows: wait 4 seconds for biowiper to close before it measures the enabled external voltage currents.

#iiDS

Display operating status and setup parameters.

Equivalent to Status on Toolbar.

List below includes, where applicable, command used to modify parameter.

- firmware version, serial number, date and time [MMDDYY= and HHMMSS=, or #iiMMDDYY= and #iiHHMMSS=]
- voltages and currents (main and back-up lithium battery voltages, operating and pump current, and external voltage currents)
- logging status (not logging, logging, waiting to start at . . ., or unknown status)
- sample interval [#iiSampleInterval=] and number of measurements to take and average per sample [#iiNCycles=]
- number of samples and available sample space in memory
- pump turn-on parameter [#iiMooredPumpMode=], and turn-on delay [#iiDelayBeforeSampling=]
- battery cut-off voltage
- pressure sensor type [#iiPType=] and range [#iiPRange=]
- sample secondary temperature sensor (SBE 38) [#iiSBE38=?]
sample external voltages 0, 1, 2, and 3? [#iiVolt0= through #iiVolt3=]
- output format [#iiOutputFormat=]
- output sample number [#iiOutputSN=], salinity [#iiOutputSal=], and sound velocity [#iiOutputSV=] with each sample? (only if output format = converted decimal)
- Output sigma-t, voltage, and current with each sample [#iiOutputUCSD=?] (only if output format = converted decimal; only appears in response if set to Y)

Example: 16plus-IM with ID=01

```
S>#01DS
SBE 16plus-IM V 1.2a SERIAL NO. 4000 01 Mar 2006 14:02:13 [MMDDYY=, HHMMSS=]
vbatt = 9.6, vlith = 8.5, ioper = 61.2 ma, ipump = 25.5 ma
status = not logging
sample interval = 15 seconds, number of measurements per sample = 1 [#iiSampleInterval=, #iiNCycles=]
samples = 0, free = 559234
run pump for 0.5 sec, delay before sampling = 0.0 seconds [#iiMooredPumpMode=, #iiDelayBeforeSampling=]
battery cutoff = 7.5 volts
pressure sensor = strain gauge, range = 1000.0 [#iiPType=, #iiPRange=]
SBE 38=no, Ext Volt 0=no, Ext Volt 1=no, Ext Volt 2=no, Ext Volt 3=no [#iiSBE38=, #iiVolt0= to #iiVolt3=]
output format = converted decimal [#iiOutputFormat=]
output sample number = yes, output salinity = no, output sound velocity = no
[#iiOutputSN=, #iiOutputSal=, #iiOutputSV=]
```

General Setup Commands

Notes:

- **#iiDDMMYY=** and **#iiMMDDYY=** are equivalent. Either can be used to set the date.
- **Always set date and then time.** If a new date is entered but not a new time, the new date will not be saved. If a new time is entered without first entering a new date, the date will reset to the last date it was set for with **#iiMMDDYY=** or **#iiDDMMYY=**.

#iiMMDDYY=mmddySet real-time clock month, day, and year. Must be followed by **#iiHHMMSS=** to set time.**#iiDDMMYY=ddmmyy**Set real-time clock day, month, and year. Must be followed by **#iiHHMMSS=** to set time.**#iiHHMMSS=hhmmss**

Set real-time clock hour, minute, and second.

Example: Set current date and time for 16plus-IM with ID=01 to 05 October 2004 12:00:00.

```
S>#01MMDDYY=100504
```

```
S>#01HHMMSS=120000
```

or

```
S>#01DDMMYY=051004
```

```
S>#01HHMMSS=120000
```

Note:

Pump operation is affected by both **#iiMooredPumpMode=** and **#iiDelayBeforeSampling=**. See *Pump Operation*.

#iiMooredPumpMode=x**x=0:** No pump.

x=1: Run pump for 0.5 seconds before each sample (typical for pumping through conductivity cell only, with no auxiliary sensors connected to plumbing).

x=2: Run pump during each sample (typical for pumping through conductivity cell and in-line auxiliary sensor).

Note:

#iiNCycles= and **#iiDelayBeforeSampling=** affect the time required to sample. If these are too high, the 16plus-IM is unable to take the required number of measurements and do the calculations within **#iiSampleInterval=**. When it is beginning to log, the 16plus-IM checks all parameters, and if necessary it internally increases **#iiSampleInterval=**.

#iiNCycles=x

x= number of measurements to take and average for each sample (default = 1). 16plus-IM takes and averages **#iiNCycles=** measurements (each 0.25 seconds apart) for each sample; averaged data is stored in FLASH memory. Maximum **#iiNCycles=** is *smaller of 255 or* $[4 * (\text{\#iiSampleInterval} - 3)]$. If **#iiPType=3** (Quartz pressure sensor), **#iiNCycles=** must be even (2, 4, 6, etc.); 16plus-IM adds 1 to **#iiNCycles=** if you enter odd number.

General Setup Commands (*continued*)**Notes:**

- **#iiInitLogging** and **#iiSampleNumber=0** have identical effects. Use either command to initialize logging.
- Initializing logging sets sample and header number to 0 *internally*. However, for data output, the first sample and header number is 1.
- **Do not initialize logging until all data has been uploaded.** These commands do not delete data; they reset the data pointer. **If you accidentally initialize logging before uploading, recover data as follows:**
 1. Set **#iiSampleNumber=a** and **#iiHeaderNumber=b**, where **a** and **b** are your estimate of number of samples and headers in memory.
 2. Upload data. If **a** is more than actual number of samples or **b** is more than actual number of headers in memory, data for non-existent samples/headers will be bad, random data. Review uploaded data file carefully and delete any bad data.
 3. If desired, increase **a** and/or **b** and upload data again, to see if there is additional valid data in memory.

#iiInitLogging

Initialize logging - after all previous data has been uploaded from 16plus-IM, initialize logging before starting to log again to make entire memory available for recording. Command sets sample number (**#iiSampleNumber=**) and header number (**#iiHeaderNumber=**) to 0 internally. If these are not set to 0, data will be stored after last recorded sample. **Do not send #iiInitLogging until all existing data has been uploaded.**

#iiSampleNumber=x

x= sample number for first sample when logging begins. After all previous data has been uploaded from 16plus-IM, send **#iiSampleNumber=0** (sets sample and header number to 0 internally) before starting to log to make entire memory available for recording. If not set to 0, data will be stored after last recorded sample. **Do not send #iiSampleNumber=0 until all existing data has been uploaded.**

#iiHeaderNumber=x

x= header number for when logging begins. Typically only used to recover data if you accidentally initialize logging (using **#iiInitLogging** or **#iiSampleNumber=0**) before uploading all existing data. 16plus-IM writes a new header each time autonomous sampling is started and / or after every 1000 samples are stored in memory.

#iiFlashInit

Map bad blocks and erase FLASH memory, **destroying all data**. 16plus-IM requires you to enter command twice, to provide verification before it proceeds. All data bits are set to 1. Sample number, header number, and data pointers are set to 0. Allow 15 minutes for process.

Send command (after uploading all data) if there are FLASH Read errors in Status (**#iiDS**) response. If not encountering errors, **#iiFlashInit** is optional, as 16plus-IM writes over previously recorded information when **#iiInitLogging** is used before beginning logging. However, knowledge of initial memory contents (i.e., all 1's) can be useful cross-check when data is retrieved.

Pressure Sensor Setup Commands

Notes:

- The 16plus-IM requires verification when command for selection of pressure sensor is sent. Instrument responds: this command will change the scan length and initialize logging. Proceed Y/N? Press Y and the Enter key to proceed. The 16plus-IM responds: Scan length has changed, initializing logging.
- The 16plus-IM configuration (.con) file must match this selection of **#iiPType=** when processing uploaded data. View and edit the .con file in SBE Data Processing. Note that **#iiPType=** is factory-set to match the ordered instrument configuration.

#iiPType=x

Pressure sensor type:

x=0: No pressure sensor.**x=1:** Strain gauge.

x=3: Quartz with temperature compensation. Requires even **#iiNCycles=** (2, 4, 6, etc.); 16plus-IM adds 1 to **#iiNCycles=** if you enter odd number.

#iiRefPress=x

x= reference pressure (gauge) in decibars to use if 16plus-IM does not include pressure sensor; 16plus-IM uses reference pressure in conductivity, salinity, and sound velocity calculation. Entry ignored if 16plus-IM includes pressure sensor. Value entered for **#iiRefPress=** is displayed in calibration coefficient (**#iiDCal**) command response if 16plus-IM does not include pressure sensor.

Voltage Sensor Setup Commands

Notes:

- The 16plus-IM requires verification when commands for selection of number of external voltages are sent. Instrument responds: this command will change the scan length and initialize logging. Proceed Y/N? Press Y and the Enter key to proceed. The 16plus-IM responds: Scan length has changed, initializing logging.
- The 16plus-IM configuration (.con) file must match this selection of number of external voltages when viewing real-time data or processing uploaded data. View and edit the .con file in SBE Data Processing. Note that these parameters are factory-set to match the ordered instrument configuration.
- External voltage numbers 0, 1, 2, and 3 correspond to wiring of sensors to a voltage channel on the 16plus-IM end cap (see *Dimensions and End Cap Connectors* in Section 2: Description of 16plus-IM). However, in the .con file, voltage 0 is the first external voltage in the data stream, voltage 1 is the second, etc.

#iiVolt0=x

x=Y: Enable external voltage 0.
x=N: Do not enable external voltage 0.

#iiVolt1=x

x=Y: Enable external voltage 1.
x=N: Do not enable external voltage 1.

#iiVolt2=x

x=Y: Enable external voltage 2.
x=N: Do not enable external voltage 2.

#iiVolt3=x

x=Y: Enable external voltage 3. #iiVolt3=Y is required if PAR sensor connected to optional PAR connector on 16plus-IM.
x=N: Do not enable external voltage 3.

Example: Enable voltage sensors wired to channels 0 and 3 on end cap; ID=01 (user input in bold).

```
S>#01VOLT0=Y
S>#01VOLT1=N
S>#01VOLT2=N
S>#01VOLT3=Y
```

There will be 2 external sensor voltages in data stream. In .con file (in SBE Data Processing), indicate 2 external voltage channels. Voltage 0 corresponds to sensor wired to external voltage channel 0; voltage 1 corresponds to sensor wired to external voltage channel 3.

Notes:

- Set **RelayMax=** (time SIM waits for reply from 16plus-IM before it times out) longer than **#iiDelayBeforeSampling=**.
- If **#iiDelayBeforeSampling=** is too high, the 16plus-IM will not be able to take **#iiNCycles=** samples within **#iiSampleInterval=** seconds; the 16plus-IM internally increases **#iiSampleInterval=** to the smallest feasible number.
- Pump operation is affected by both **#iiMooredPumpMode=** and **#iiDelayBeforeSampling=**. See *Pump Operation*.

#iiDelayBeforeSampling=x

x= time (seconds) to wait after switching on external voltage before sampling (0-32,000 seconds). Default 0 seconds. Typical value if using:

- SBE 43 oxygen sensor – dependent on membrane thickness and on water temperature. Use with **#iiMooredPumpMode=2**. See *Pump Operation*.

- Beckman- or YSI-type oxygen sensor – 120 to 180 seconds is required to provide time for sensor to polarize. Use with **#iiMooredPumpMode=2**. See *Pump Operation*.

- Sea Tech fluorometer - 15 seconds is required to provide time for sensor to stabilize.

Note:

If an ECO-FL with Bio-Wiper is installed and **#iiBiowiper=N**, sending **#iiDS** will open the Bio-Wiper, but not provide enough powered time to close it again. If you then deploy the instrument with the Bio-Wiper open and with a delayed start time, the ECO-FL may become fouled because the Bio-Wiper will remain open until the first sample is completed.

#iiBiowiper=x

x=Y: Configuration includes WET Labs ECO-FL fluorometer with Bio-Wiper. With this setup, 16plus-IM is powered longer for **#iiDS** command, providing sufficient time for Bio-Wiper to open and then shut again if Bio-Wiper is set up to take 1 measurement for each sample (see *Application Note 72* for details).

x=N (default): Configuration does not include ECO-FL with Bio-Wiper.

RS-232 Sensor Setup Commands

Notes:

- **You must set up the SBE 38 to interface with the 16plus-IM** before connecting it to the 16plus-IM. Connect the SBE 38 directly to the computer, power with an external power supply, and (with SEATERM) set:
 - Interface to RS-232 (**Interface=232**);
 - Baud rate to 1200 (**Baud=1200**);
 - Sampling to begin when power applied (**AutoRun=Y**); and
 - Output format to converted data (**Format=C**)
 See the SBE 38 manual for command details.
- The 16plus-IM configuration (.con) file must match this selection of RS-232 sensor when viewing real-time data or processing uploaded data. View and edit the .con file in SBE Data Processing. Note that these parameters are factory-set to match the ordered instrument configuration.
- The 16plus-IM requires verification when **#iiSBE38=** is sent. The 16plus-IM responds: `this command will change the scan length and initialize logging.` Proceed Y/N? Press Y and the Enter key to proceed. The 16plus-IM responds: `Scan length has changed, initializing logging.`

#iiSBE38=x

x=Y: Enable SBE 38 secondary temperature sensor.

x=N: Do not enable SBE 38.

Output Format Setup Commands

Note:

Output format does not affect how data is stored in FLASH memory. Sea-Bird's data processing software (SBE Data Processing) requires data in raw hexadecimal (**#iiOutputFormat=0**).

Typical use of the output format command is:

- Before beginning logging, set the output format to converted decimal (**#iiOutputFormat=3**) for ease in viewing data in SEATERM (if you will be transmitting occasional data samples while logging).
- After stopping sampling, use SEATERM's Upload button to upload data from memory. This automatically resets the format to raw hex (**#iiOutputFormat=0**), so the data is compatible with SBE Data Processing.

#iiOutputFormat=x

x=0: Output raw frequencies and voltages in hexadecimal; required for data that will be processed with Sea-Bird software. When using SEATERM's Upload button, SEATERM sends **#iiOutputFormat=0**, causing 16*plus*-IM to upload data in memory in raw hex, regardless of user-programmed **#iiOutputFormat**.

x=1: Output converted (engineering units) data in hexadecimal.

x=2: Output raw frequencies and voltages in decimal.

x=3: Output converted (engineering units) data in decimal; required to output salinity, sound velocity, or serial number and sample number.

#iiOutputSal=x

x=Y: Calculate and output salinity (psu). Only applies if **#iiOutputFormat=3**.

x=N: Do not.

#iiOutputSV=x

x=Y: Calculate and output sound velocity (m/sec), using Chen and Millero formula (UNESCO Technical Papers in Marine Science #44). Only applies if **#iiOutputFormat=3**.

x=N: Do not.

#iiOutputUCSD=x

x=Y: Calculate and output density sigma-t (kg/m³), battery voltage, and operating current (mA) with data polled while logging. Voltage and current measured after delay before sampling, but before sampling. Only applies if **#iiOutputFormat=3**.

x=N: Do not.

Note:

#iiOutputSN=Y could be used to verify that logging is occurring at the correct rate. For example, while logging:

1. Send **#iiSL**.
2. After some interval, send **#iiSL** again. Compare change in output sample numbers to expected change based on **#iiSampleInterval=**.

#iiOutputSN=x

x=Y: Output six-character sample number (number of samples in memory at time sample was taken) with data from **Dataii**, **#iiSL**, **#iiSLT**, **#iiTS**, and **#iiTSSOn**. Only applies if **#iiOutputFormat=3**.

x=N: Do not.

Autonomous Sampling (logging) Commands

Notes:

- In SEATERM, to save data to a file (if you will be transmitting occasional data samples while logging), click Capture on the Toolbar before beginning logging.
- If the 16plus-IM is sampling and the voltage is less than the cut-off voltage (7.5 volts) for five consecutive scans, the 16plus-IM halts logging and displays WARNING: LOW BATTERY VOLTAGE.

Autonomous sampling commands direct the 16plus-IM to sample at pre-programmed intervals. When commanded to start sampling with **#iiStartNow** or **#iiStartLater**, the 16plus-IM takes samples, stores the data in its FLASH memory, and enters quiescent (sleep) state between samples.

To start sampling, use **#iiStartNow** or **#iiStartLater**. Sampling starts **#iiSampleInterval=** seconds after receipt of **#iiStartNow**. The first time sampling starts after receipt of initialize logging (**#iiInitLogging**), data recording starts at the beginning of memory and any previously recorded data is written over. When **#iiStop** is sent, recording stops. Each time **#iiStartNow** or **#iiStartLater** is sent again, recording continues, with new data stored after previously recorded data. A new header is written each time logging starts and every 1000 samples thereafter.

The 16plus-IM responds only to **#iiDS**, **#iiDCal**, **#iiTS**, **#iiSL**, **#iiSLT**, and **#iiStop** while logging. If you wake the 16plus-IM (for example, to send **#iiDS** to check logging progress), it temporarily stops sampling. Sampling resumes when the Acquisition microcontroller goes back to sleep (as soon as it finishes processing the command).

Note:

#iiNCycles= and **#iiDelayBeforeSampling=** affect the time required to sample. If these are too high, the 16plus-IM is unable to take the required number of measurements and do the calculations within **#iiSampleInterval=**. When it is beginning to log, the 16plus-IM checks all parameters, and if necessary it internally increases **#iiSampleInterval=**.

#iiSampleInterval=x x= interval (seconds) between samples
(10 – 14,400 seconds).

Example: If **#iiSampleInterval=10** and **#iiNCycles=4**, every 10 seconds 16plus-IM takes 4 samples (each 0.25 seconds apart), averages data from 4 samples, and stores averaged data in FLASH memory.

Notes:

- **#iiStartDDMMYY=** or **#iiStartMMDDYY=** must be followed by **#iiStartHHMMSS=** to set delayed start time.
- **#iiStartDDMMYY=** and **#iiStartMMDDYY=** are equivalent. Either can be used to set the delayed start time.
- After receiving **#iiStartLater**, the 16plus-IM displays `waiting to start at ...` in reply to **#iiDS**. Once logging has started, the **#iiDS** reply displays `logging`.
- If the delayed start time has already passed when **#iiStartLater** is received, the 16plus-IM executes **#iiStartNow**.

#iiStartNow Start autonomous sampling now.

#iiStartMMDDYY=mmddy Set delayed start month, day, and year.

#iiStartDDMMYY=ddmmy Set delayed start day, month, and year.

#iiStartHHMMSS=hmmss Set delayed start hour, minute, and second.

#iiStartLater Start autonomous sampling at delayed start date and time.

Example: Program 16plus-IM with ID=01 to start logging on 20 January 2005 12:00:00 (user input in bold).

```
S>#01STARTMMDDYY=012005
S>#01STARTHHMMSS=120000
S>#01STARTLATER
or
S>#01STARTDDMMYY=200105
S>#01STARTHHMMSS=120000
S>#01STARTLATER
```

Notes:

- You may need to send **#iiStop** several times to get the 16plus-IM to respond.
- You must stop logging before uploading data.

#iiStop Stop autonomous sampling or stop waiting to start autonomous sampling (if **#iiStartLater** was sent but sampling has not begun yet). Press Enter key to get S> prompt before entering **#iiStop**.

Data Upload Commands

Notes:

- **Use Upload on the Toolbar or Upload Data in the Data menu to upload data that will be processed by SBE Data Processing.** Manually entering **#iiDDb,e** does not produce data with the required header information for processing by our software. These commands are included here for reference for users who are writing their own software.
- To save data to a file, click Capture on the Toolbar before entering **#iiDDb,e** or **#iiDHb,e**.
- See *Data Output Formats*.

Stop sampling autonomously before uploading data.

#iiDDb,e

Upload data from sample **b** to sample **e**. If **b** and **e** are omitted, all data is uploaded. First sample is number 1.

Example: Upload samples 1 - 199 to a file for a 16plus-IM with ID=01 (user input in bold):
(Click Capture on Toolbar and enter desired filename in dialog box.)
S>**#01DD1,199**

#iiDHb,e

Upload headers from header **b** to header **e**. If **b** and **e** are omitted, all headers are uploaded. First header is number 1.

Header includes:

- header number
- month, day, hour, minute, and second when header was written
- first and last sample for header
- interval between samples (**#iiSampleInterval=**)
- reason logging was halted (batfail = battery voltage too low; stop cmd = received **#iiStop** or Home or Ctrl Z character; timeout = error condition; unknown = error condition; ?????? = error condition)

Example: For 16plus-IM with ID=01, upload second header to a file (user input in bold):
(Click Capture on Toolbar and enter desired filename in dialog box.)

S>**#01DH2**

16plus-IM responds:

hdr 2 30 Nov 2000 12:30:33 samples 35 to 87, int=60, stop=stop cmd

Polled Sampling Commands

Note:

The 16plus-IM has a buffer that stores the most recent data sample. Unlike data in the FLASH memory, data in the buffer is erased upon removal or failure of power.

These commands request a single sample. The 16plus-IM always stores data for the most recent sample in its buffer. Some Sampling commands also store data in FLASH memory - the 16plus-IM will not execute the *store data in FLASH memory* portion of those commands while sampling autonomously.

#iiSL

Output last sample from buffer (sample obtained with sampling command, or latest sample from logging).

#iiSLT

Output last sample from buffer, then take new sample and store data in buffer.
Data is not stored in FLASH memory.

#iiTS

Take new sample, store data in buffer, and output data. **Data is not stored in FLASH memory.**

#iiTSSOn

Take new sample, store data in buffer and **FLASH memory**, and output data.

Testing Commands

The 16plus-IM takes and outputs **100 samples** for each test (except as noted); data is **not** stored in FLASH memory.

Note:**If your 16plus-IM includes an optional pump:**

Testing commands do not automatically turn the pump on. Thus, for instruments plumbed with the pump, they report data from essentially the same sample of water for all 100 measurements, because the pump does not run but the pump and associated plumbing prevent water from freely flowing through the conductivity cell and other plumbed sensors (for example, dissolved oxygen sensor). To get data from fresh samples, send **#iiPumpOn** before sending a testing command, and then send **#iiPumpOff** when the test is complete.

#iiTT	Measure temperature, output converted data.												
#iiTC	Measure conductivity, output converted data.												
#iiTP	Measure pressure (strain gauge or Quartz), output converted data.												
#iiTV	Measure four external voltage channels, output converted data.												
#iiTF	Measure frequency (Quartz pressure sensor), output converted data.												
#iiT38	Measure SBE 38 (secondary temperature), output converted data.												
#iiTTR	Measure temperature, output raw data.												
#iiTCR	Measure conductivity, output raw data.												
#iiTPR	Measure pressure (strain gauge or Quartz), output raw data.												
#iiTVR	Measure voltages read by A/D converter, output raw data:												
	<table border="1"> <thead> <tr> <th>Column</th> <th>Output</th> </tr> </thead> <tbody> <tr> <td>1</td> <td>Main battery voltage / 11</td> </tr> <tr> <td>2</td> <td>Back-up lithium battery voltage / 3.741</td> </tr> <tr> <td>3</td> <td>External current / 333.33</td> </tr> <tr> <td>4</td> <td>Pressure temperature voltage</td> </tr> <tr> <td>5 – 8</td> <td>External voltages</td> </tr> </tbody> </table>	Column	Output	1	Main battery voltage / 11	2	Back-up lithium battery voltage / 3.741	3	External current / 333.33	4	Pressure temperature voltage	5 – 8	External voltages
Column	Output												
1	Main battery voltage / 11												
2	Back-up lithium battery voltage / 3.741												
3	External current / 333.33												
4	Pressure temperature voltage												
5 – 8	External voltages												
#iiTFR	Measure frequency (Quartz pressure sensor), output raw data.												
#iiPumpOn	Turn pump on for testing purposes. Use this command: <ul style="list-style-type: none"> • Before sending testing command to obtain pumped data from sensors plumbed with the pump, or • To test pump. 												
#iiPumpOff	Turn pump off for testing purposes.												

Calibration Coefficients Commands

Notes:

- Dates shown are when calibrations were performed. Calibration coefficients are initially factory-set and should agree with Calibration Certificate shipped with SBE 16plus-IM.
- See individual Coefficient Commands below for definitions of the data in the example.

#iiDCal

Display calibration coefficients.
Equivalent to Coefficients on Toolbar.

Example: Display coefficients for 16plus-IM with ID=01 with a Quartz pressure sensor (user input in bold).

```
S>#01dca1
SeacatPlus V 1.2a SERIAL NO. 4000 02 Mar 2006 14:46:05
temperature: 01-jul-04
  TA0 = -3.178124e-06
  TA1 = 2.751603e-04
  TA2 = -2.215606e-06
  TA3 = 1.549719e-07
  TOFFSET = 0.000000e+00
conductivity: 01-jul-04
  G = -9.855242e-01
  H = 1.458421e-01
  I = -3.290801e-04
  J = 4.784952e-05
  CF0 = 2.584100e+03 (not used in calculations; ignore)
  CPCOR = -9.570000e-08
  CTCOR = 3.250000e-06
  CSLOPE = 1.000000e+00
pressure S/N , range = 2000 psia: 14-jul-04
  PC1 = 0.000000e+00
  PC2 = 0.000000e+00
  PC3 = 0.000000e+00
  PD1 = 0.000000e+00
  PD2 = 0.000000e+00
  PT1 = 0.000000e+00
  PT2 = 0.000000e+00
  PT3 = 0.000000e+00
  PT4 = 0.000000e+00
  PSLOPE = 1.000000e+00
  POFFSET = 0.000000e+00
volt 0: offset = 0.000000e+00, slope = 1.000000e+00
volt 1: offset = 0.000000e+00, slope = 1.000000e+00
volt 2: offset = 0.000000e+00, slope = 1.000000e+00
volt 3: offset = 0.000000e+00, slope = 1.000000e+00
EXTFREQSF = 1.000000e+00
```

Calibration Coefficients Commands (*continued*)**Notes:**

- F = floating point number
S = string with no spaces
- If using an SBE 38 (secondary temperature sensor), its calibration coefficients are not stored in the 16plus-IM EEPROM. View and/or modify the SBE 38's calibration coefficients by connecting the SBE 38 to the computer directly and using SEATERM.
- If using auxiliary A/D sensors (**#iiVolt0=** through **#iiVolt3=**), their calibration coefficients are not stored in the 16plus-IM EEPROM, but are stored in the 16plus-IM configuration (.con) file. View and/or modify the calibration coefficients using SBE Data Processing's Configure menu.

The individual Coefficient Commands listed below are used to modify a particular coefficient or date:

Temperature

#iiTCalDate=S	S=calibration date
#iiTA0=F	F=A0
#iiTA1=F	F=A1
#iiTA2=F	F=A2
#iiTA3=F	F=A3
#iiTOffset=F	F=offset correction

Conductivity

#iiCCalDate=S	S=calibration date
#iiCG=F	F=G
#iiCH=F	F=H
#iiCI=F	F=I
#iiCJ=F	F=J
#iiCPCor=F	F=pcor
#iiCTCor=F	F=tcor
#iiCSlope=F	F=slope correction
#iiCF0=F	F=0 value (not applicable to SBE 16plus-IM)

Pressure - General

#iiPCalDate=S	S=calibration date
#iiPRange=F	F=sensor full scale range (psia)
#iiPOffset=F	F=offset correction (decibars)

Strain Gauge Pressure

#iiPA0=F	F=A0
#iiPA1=F	F=A1
#iiPA2=F	F=A2
#iiPTempA0=F	F=pressure temperature A0
#iiPTempA1=F	F=pressure temperature A1
#iiPTempA2=F	F=pressure temperature A2
#iiPTCA0=F	F=pressure temperature compensation ptca0
#iiPTCA1=F	F=pressure temperature compensation ptca1
#iiPTCA2=F	F=pressure temperature compensation ptca2
#iiPTCB0=F	F=pressure temperature compensation ptcb0
#iiPTCB1=F	F=pressure temperature compensation ptcb1
#iiPTCB2=F	F=pressure temperature compensation ptcb2

Quartz Pressure

#iiPC1=F	F=C1
#iiPC2=F	F=C2
#iiPC3=F	F=C3
#iiPD1=F	F=D1
#iiPD2=F	F=D2
#iiPT1=F	F=T1
#iiPT2=F	F=T2
#iiPT3=F	F=T3
#iiPT4=F	F=T4
#iiPSlope=F	F=slope correction

External Frequency

#iiExtFreqSF=F	F=external frequency scale factor (applies to Quartz pressure sensor)
-----------------------	---

Data Output Formats

Note:

For the date and time output with the data, time is the time at the **start** of the sample, after:

- a small amount of time (1 to 2 seconds) for the 16plus-IM to wake up and prepare to sample, and
- any programmed **#iiDelayBeforeSampling=**.

For example, if the 16plus-IM is programmed to wake up and sample at 12:00:00, and **#iiDelayBeforeSampling=20**, the output time for the first sample will be 12:00:21 or 12:00:22.

The SBE 16plus-IM stores data in a compact machine code. Data is converted and output in the user-selected format without affecting data in memory. Because memory data remains intact until deliberately overwritten, you can upload in one format, then choose another format and upload again.

Output format is dependent on **#iiOutputFormat= (0, 1, 2, or 3)** and on the command used to retrieve the data, as detailed below. The inclusion of some data is dependent on system configuration - if the system does not include the specified sensor, the corresponding data is not included, shortening the data string.

#iiOutputFormat=0 (raw frequencies and voltages in Hex)

Data is output in the order listed, with no spaces or commas between parameters. Shown with each parameter is the number of digits, and how to calculate the parameter from the data (use the decimal equivalent of the hex data in the equations).

Uploaded Data (from #iiDDB,e, Upload on Toolbar, or Upload Data in Data menu) or Polled Data (from #iiSL, #iiSLT, #iiTS, or #iiTSSon):

1. Temperature
A/D counts = tttttt
2. Conductivity
conductivity frequency (Hz) = cccccc / 256
3. Strain gauge pressure sensor pressure (if #iiPType=1)
A/D counts = pppppp
4. Strain gauge pressure sensor pressure temperature compensation (if #iiPType=1)
pressure temperature compensation voltage = vvvvv / 13,107
5. Quartz pressure sensor pressure (if #iiPType=3)
Quartz pressure frequency (Hz) = pppppp / 256
6. Quartz pressure sensor temperature compensation (if #iiPType=3)
Quartz temperature compensation voltage = vvvvv / 13,107
7. External voltage 0 (if #iiVolt0=Y)
external voltage 0 = vvvvv / 13,107
8. External voltage 1 (if #iiVolt1=Y)
external voltage 1 = vvvvv / 13,107
9. External voltage 2 (if #iiVolt2=Y)
external voltage 2 = vvvvv / 13,107
10. External voltage 3 (if #iiVolt3=Y)
external voltage 3 = vvvvv / 13,107
11. SBE 38 secondary temperature (if #iiSBE38=Y)
SBE 38 temperature (°C, ITS-90) = (ttttt / 100,000) - 10
12. Time
seconds since January 1, 1980 = ssssssss

Notes:

- When using SEATERM's Upload button, SEATERM sends **#iiOutputFormat=0**. This causes the 16plus-IM to upload data in memory in raw hex, regardless of the user-programmed format, providing the data in a format that Sea-Bird's data processing software can use.
- Our software uses the equations shown to perform these calculations; alternatively, you can use the equations to develop your own processing software.
- The pressure sensor is an absolute sensor, so its **raw** output includes the effect of atmospheric pressure (14.7 psi). As shown on the Calibration Sheet, Sea-Bird's calibration (and resulting calibration coefficients) is in terms of psia. However, when outputting pressure in **engineering units**, the 16plus-IM outputs pressure relative to the ocean surface (i.e., at the surface the output pressure is 0 decibars). The 16plus-IM uses the following equation to convert psia to decibars:
pressure (db) =
[pressure (psia) - 14.7] * 0.689476
- Although **#iiOutputFormat=0** outputs **raw** data for temperature, conductivity, etc., it outputs engineering units for SBE 38 data.

*Example: 16plus-IM with strain gauge pressure sensor and 2 external voltages sampled,
example scan = tttttccccppppvvvvvvvvvvvsssssss
= 0A53711BC7220C14C17D820305059425980600*

- Temperature = ttttt = 0A5371 (676721 decimal);
temperature A/D counts = 676721
- Conductivity = 1BC722 (1820450 decimal);
conductivity frequency = 1820450 / 256 = 7111.133 Hz
- Strain gauge pressure = pppppp = 0C14C1 (791745 decimal);
Strain gauge pressure A/D counts = 791745
- Strain gauge temperature compensation =
vvvv = 7D82 (32,130 decimal);
Strain gauge temperature = 32,130 / 13,107 = 2.4514 volts
- First external voltage = vvvv = 0305 (773 decimal);
voltage = 773 / 13,107 = 0.0590 volts
- Second external voltage = vvvv = 0594 (1428 decimal);
voltage = 1428 / 13,107 = 0.1089 volts
- Time = sssssss = 25980600 (630,720,000 decimal)
seconds since January 1, 1980 = 630,720,000

Polled Data (from Dataii):

Data is preceded by the 16plus-IM two-character decimal ID and a comma. The rest of the data stream is as described above.

Example: 16plus-IM with strain gauge pressure sensor and 2 external voltages sampled.

>DATA01

01, 0A53711BC7220C14C17D820305059425980600

Same as example above, but hex data stream is preceded by 16plus-IM ID (01).

#iiOutputFormat=1 (engineering units in Hex)

Data is output in the order listed, with no spaces or commas between the parameters. Shown with each parameter is the number of digits, and how to calculate the parameter from the data (use the decimal equivalent of the hex data in the equations).

**Uploaded Data (from #iiDDb,e) or
Polled Data (from #iiSL, #iiSLT, #iiTS, or #iiTSSOn):**

1. Temperature
temperature (°C, ITS-90) = (ttttt / 100,000) - 10
2. Conductivity
Conductivity (S/m) = (ccccc / 1,000,000) - 1
3. Pressure (Quartz or strain gauge - #iiPType=1 or 3)
pressure (decibars) = (pppppp / 1,000) - 100
4. External voltage 0 (if #iiVolt0=Y)
external voltage 0 = vvvv / 13,107
5. External voltage 1 (if #iiVolt1=Y)
external voltage 1 = vvvv / 13,107
6. External voltage 2 (if #iiVolt2=Y)
external voltage 2 = vvvv / 13,107
7. External voltage 3 (if #iiVolt3=Y)
external voltage 3 = vvvv / 13,107
8. SBE 38 secondary temperature (if #iiSBE38=Y)
SBE 38 temperature (°C, ITS-90) = (ttttt / 100,000) - 10
9. Time
seconds since January 1, 1980 = ssssssss

*Example: 16plus-IM with strain gauge pressure sensor and 2 external voltages sampled, example scan = tttttccccccppppppvvvvvvvsssssss
= 3385C40F42FE0186DE0305059425980600*

- Temperature = ttttt = 3385C4 (3376580 decimal);
temperature (°C, ITS-90) = (3376580 / 100,000) - 10 = 23.7658
- Conductivity = cccccc = 0F42FE (1000190 decimal);
conductivity (S/m) = (1000190 / 1,000,000) - 1 = 0.00019
- Pressure = pppppp = 0186DE (100062 decimal);
pressure (decibars) = (100062 / 1,000) - 100 = 0.062
- First external voltage = vvvv = 0305 (773 decimal);
voltage = 773 / 13,107 = 0.0590 volts
- Second external voltage = vvvv = 0594 (1428 decimal);
voltage = 1428 / 13,107 = 0.1089 volts
- Time = ssssssss = 25980600 (630,720,000 decimal)
seconds since January 1, 1980 = 630,720,000

Polled Data (from Dataii):

Data is preceded by the 16plus-IM two-character decimal ID and a comma. The rest of the data stream is as described above.

Example: 16plus-IM with strain gauge pressure sensor and 2 external voltages sampled.

>DATA01

01, 3385C40F42FE0186DE0305059425980600

Same as example above, but hex data stream is preceded by 16plus-IM ID (01).

#iiOutputFormat=2 (raw frequencies and voltages in decimal)

Data is output in the order listed, with a comma followed by a space between each parameter. Shown with each parameter are the number of digits and the placement of the decimal point. Leading zeros are suppressed, except for one zero to the left of the decimal point.

**Uploaded Data (from #iiDDb,e) or
Polled Data (from #iiSL, #iiSLT, #iiTS, or #iiTSSOn):**

1. Temperature
A/D counts = ttttt
2. Conductivity
conductivity frequency (Hz) = cccc.ccc
3. Strain gauge pressure sensor pressure (if #iiPType=1)
A/D counts = pppppp
4. Strain gauge pressure sensor pressure temperature compensation
(if #iiPType=1)
pressure temperature compensation voltage = v.vvvv
5. Quartz pressure sensor pressure (if #iiPType=3)
Quartz pressure frequency (Hz) = ppppp.ppp
6. Quartz pressure sensor temperature compensation (if #iiPType=3)
Quartz temperature compensation voltage = v.vvvv
7. External voltage 0 (if #iiVolt0=Y)
external voltage 0 = v.vvvv
8. External voltage 1 (if #iiVolt1=Y)
external voltage 1 = v.vvvv
9. External voltage 2 (if #iiVolt2=Y)
external voltage 2 = v.vvvv
10. External voltage 3 (if #iiVolt3=Y)
external voltage 3 = v.vvvv
11. SBE 38 secondary temperature (if #iiSBE38=Y)
SBE 38 temperature (°C, ITS-90) = ttt.tttt
12. Time
date, time = dd mmm yyyy, hh:mm:ss (day month year hour:minute:second)

*Example: 16plus-IM with strain gauge pressure sensor and 2 external voltages sampled,
example scan = ttttt, cccc.ccc, pppppp, v.vvvv, v.vvvv, v.vvvv, dd mmm yyyy, hh:mm:ss
= 676721, 7111.133, 791745, 2.4514, 0.0590, 0.1089, 12 nov 2000, 12:23:05*

- Temperature = ttttt = 676721;
temperature A/D counts = 676721
- Conductivity = cccc.ccc = 7111.133;
conductivity frequency = 7111.133 Hz
- Strain gauge pressure = pppppp = 791745;
Strain gauge pressure A/D counts = 791745
- Strain gauge temperature compensation = v.vvvv = 2.4514;
Strain gauge temperature = 2.4514 volts
- First external voltage = v.vvvv = 0.0590;
voltage = 0.0590 volts
- Second external voltage = v.vvvv = 0.1089;
voltage = 0.1089 volts
- Date, time = dd mmm yyyy, hh:mm:ss = 12 nov 2000, 12:23:05
Date, time = 12 November 2000, 12:23:05

Polled Data (from Dataii):

Data is preceded by the 16plus-IM two-character decimal ID and a comma. The rest of the data stream is as described above.

*Example: 16plus-IM with strain gauge pressure sensor and 2 external voltages sampled.
>DATA01
01, 676721, 7111.133, 791745, 2.4514, 0.0590, 0.1089, 12 nov 2000, 12:23:05
Same as example above, but data stream is preceded by 16plus-IM ID (01).*

#iiOutputFormat=3 (engineering units in decimal)

Data is output in the order listed, with a comma followed by a space between each parameter. Shown with each parameter are the number of digits and the placement of the decimal point. Leading zeros are suppressed, except for one zero to the left of the decimal point.

Uploaded Data (from #iiDDb,e):

1. Temperature
temperature (°C, ITS-90) = ttt.tttt
2. Conductivity
Conductivity (S/m) = cc.ccccc
3. Pressure (Quartz or strain gauge - #iiPType=1 or 3)
pressure (decibars) = pppp.ppp
4. External voltage 0 (if #iiVolt0=Y)
external voltage 0 = v.vvvv
5. External voltage 1 (if #iiVolt1=Y)
external voltage 1 = v.vvvv
6. External voltage 2 (if #iiVolt2=Y)
external voltage 2 = v.vvvv
7. External voltage 3 (if #iiVolt3=Y)
external voltage 3 = v.vvvv
8. SBE 38 secondary temperature (if #iiSBE38=Y)
SBE 38 temperature (°C, ITS-90) = ttt.tttt
9. Salinity (if #iiOutputSal=Y)
salinity (psu) = sss.ssss
10. Sound velocity (if #iiOutputSV=Y)
sound velocity (meters/second) = vvvv.vvv
11. Time
date, time = dd mmm yyyy, hh:mm:ss (day month year hour:minute:second)

Example: 16plus-IM with strain gauge pressure sensor and 2 external voltages sampled,
example scan = ttt.tttt, cc.ccccc, pppp.ppp, v.vvvv, v.vvvv, dd mmm yyyy, hh:mm:ss
= 23.7658, 0.00019, 0.062, 0.0590, 0.1089, 12 nov 2000, 12:23:05

- Temperature = ttt.tttt = 23.7658;
temperature (°C, ITS-90) = 23.7658
- Conductivity = cc.ccccc = 0.00019;
conductivity (S/m) = 0.00019
- Pressure = pppp.ppp = 0.062;
pressure (decibars) = 0.062
- First external voltage = v.vvvv = 0.0590;
voltage = 0.0590 volts
- Second external voltage = v.vvvv = 0.1089;
voltage = 0.1089 volts
- Date, time = dd mmm yyyy, hh:mm:ss = 12 nov 2000, 12:23:05
Date, time = 12 November 2000, 12:23:05

Polled Data (from #iiSL, #iiSLT, #iiTS, or #iiTSSOn):

- If **#iiOutputUCSD=Y** and the 16plus-IM is logging (autonomous sampling is in progress), data is followed by density sigma-t in kg/m³(ddd.ddd), battery voltage (vv.v), and operating current in mA (ccc.c), each separated by a comma and a space. The rest of the data stream is as described above for uploaded data. Note: 16plus-IM does not respond to **#iiTSSOn** while logging.
- If **#iiOutputSN=N**, data is preceded by the 16plus-IM four-character serial number and a comma. The rest of the data stream is as described above for uploaded data.
- If **#iiOutputSN=Y**, data is preceded by the 16plus-IM four-character serial number and a comma, and is followed at the very end (after **#iiOutputUCSD** data if applicable) by the six-character sample number (number of samples in memory at the time the sample was taken). The rest of the data stream is as described above for uploaded data.

Example: Serial number 4000 16plus-IM with pressure sensor and 2 external voltages sampled, and with **#iiOutputSN=Y**. Command instrument to send output from last sample taken, which was sample 11.

S>**#01SL**

4000, 23.7658, 0.00019, 0.062, 0.0590, 0.1089, 12 nov 2000, 12:23:05, 11

(same as example above for uploaded data, but data stream is preceded by serial number and followed by sample number)

Polled Data from Dataii:

- If **#iiOutputUCSD=Y**, data is followed by density sigma-t in kg/m³(ddd.ddd), battery voltage (vv.v), and operating current in mA (ccc.c), each separated by a comma and a space. The rest of the data stream is as described above for uploaded data.
- If **#iiOutputSN=N**, data is preceded by the 16plus-IM two-character ID and a comma and four-character serial number and a comma. The rest of the data stream is as described above for uploaded data.
- If **#iiOutputSN=Y**, data is preceded by the 16plus-IM two-character ID and a comma and four-character serial number and a comma, and is followed at the very end (after **#iiOutputUCSD** data if applicable) by the six-character sample number (number of samples in memory at the time the sample was taken). The rest of the data stream is as described above for uploaded data.

Example: Serial number 4000 16plus-IM with pressure sensor and 2 external voltages sampled, and with **#iiOutputSN=Y**. Command instrument to send output from last sample taken, which was sample 11.

S>**DATA01**

01, 4000, 23.7658, 0.00019, 0.062, 0.0590, 0.1089, 12 nov 2000, 12:23:05, 11

(same as example above for uploaded data, but data stream is preceded by ID and serial number and followed by sample number)

Setup for Deployment

1. Install new batteries or ensure the existing batteries have enough capacity to cover the intended deployment (see *Replacing Alkaline Batteries* in *Section 5: Routine Maintenance and Calibration*).
2. Program the 16plus-IM for the intended deployment using SEATERM (see *Section 3: Preparing for Deployment* for connection information; see this section for setup/configuration, sampling modes, pump operation, and commands):
 - A. If the system will have multiple 16plus-IMs (or other inductive instruments) on the mooring cable, verify the SBE 16plus-IM is set to *Prompt ID* to allow use of the Toolbar buttons and Menus:
 - 1) In the Configure menu, select *SBE 16plus*.
 - 2) Click on the COM Settings tab.
 - 3) For Modem/RS485 ID, click on *Prompt ID*.
 - 4) Click OK.
 - B. Click Connect on the Toolbar to begin communications with the 16plus-IM.
 - C. Ensure all data has been uploaded, and then send **#iiInitLogging** to make the entire memory available for recording. If **#iiInitLogging** is not sent, data will be stored after the last recorded sample.
 - D. Set the date and then time. Note that the date and time can be set individually for each 16plus-IM (**#iiMMDDYY=** or **#iiDDMMYY=** to set date; **#iiHHMMSS=** to set time), or globally for all 16plus-IMs online (**MMDDYY=** or **DDMMYY=** to set date; **HHMMSS=** to set time). To synchronize autonomous sampling for a system with multiple 16plus-IMs on a mooring cable, set the date and time globally, with all the 16plus-IMs online (see *Autonomous Sampling* for synchronization details).
 - E. Establish the setup and logging parameters.
 - F. Send **#DS** to verify the setup.
 - G. Use **one** of the following sequences to initiate logging:
 - **#iiStartNow** to start logging now
 - **#iiStartMMDDYY=**, **#iiStartHHMMSS=**, and **#iiStartLater** to start logging at the specified date and time

Note:

Always set date and then time. If a new date is entered but not a new time, the new date will not be saved. If a new time is entered without first entering a new date, the date will reset to the last date it was set for with **MMDDYY=**, or **DDMMYY=**, **#iiMMDDYY=**, or **#iiDDMMYY=**.

Deployment

CAUTION:

Do not use WD-40 or other petroleum-based lubricants, as they will damage the connectors.

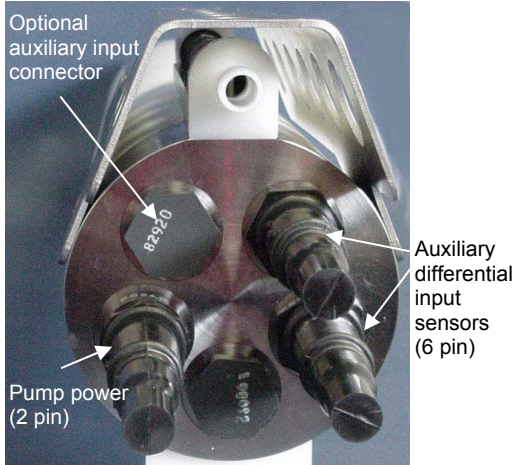

1. Install a cable or dummy plug for each connector on the 16plus-IM sensor end cap:
 - A. Lightly lubricate the inside of the dummy plug/cable connector with silicone grease (DC-4 or equivalent).
 - B. **Standard Connector** - Install the plug/cable connector, aligning the raised bump on the side of the plug/cable connector with the large pin (pin 1 - ground) on the 16plus-IM. Remove any trapped air by *burping* or gently squeezing the plug/connector near the top and moving your fingers toward the end cap. **OR** **MCBH Connector** – Install the plug/cable connector, aligning the pins.
 - C. Place the locking sleeve over the plug/cable connector. Tighten the locking sleeve finger tight only. **Do not overtighten the locking sleeve and do not use a wrench or pliers.**

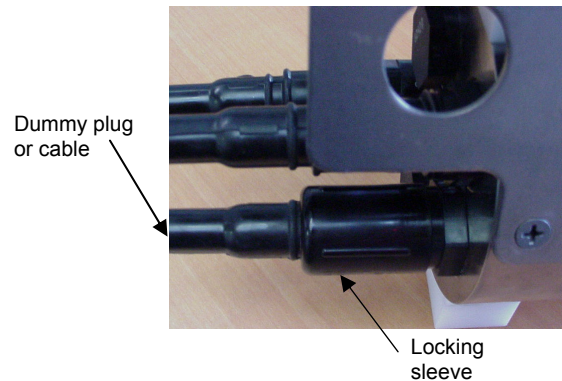

2. Connect the other end of the cables installed in Step 1 to the appropriate sensors.
3. As applicable, remove the plug(s) from the anti-foulant device cap(s), or remove the Tygon tubing (and associated barbed anti-foulant device caps) that is looped end-to-end around the conductivity cell (see *Conductivity Cell Maintenance* in *Section 5: Routine Maintenance and Calibration*). Verify that the two plastic cups contain AF24173 Anti-Foulant Devices (see *Section 5: Routine Maintenance and Calibration* for Anti-Foulant Device replacement). If using the 16plus-IM with a pump, verify that the system plumbing is correctly installed (see *Configuration Options and Plumbing* in *Section 2: Description of SBE 16plus-IM*).

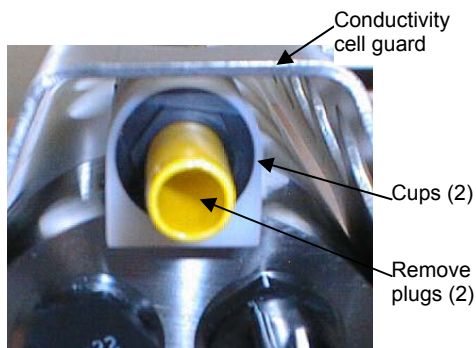

Mounting clamp, with opening sized to specified cable diameter – cable **clamped** by this bracket. Note: Installing clamp on larger cable than specified may cause damage to cable and/or modem and prevent IM communications.



For both mounting brackets – loosen hardware to separate bracket halves and mount on mooring cable

Mounting guide / inductive modem coupler – contains modem coupling toroid core. Cable goes through here but is **not clamped**, to avoid putting through tension on end cap (which could pull off end cap).

For proper communications, 2 halves of modem coupling toroid core must mate, with no gaps

4. Attach the mounting brackets to the insulated mooring cable:
 - A. Open each mounting bracket by unthreading the two large titanium hex bolts.
 - B. Place the insulated mooring cable inside the brackets' grooves.
 - C. Reinstall each bracket half with the hex bolts.
 - D. Verify that the two halves of the modem coupling toroid have come together evenly, and that the mounting clamp is secure.
5. Verify that the hardware and external fittings are secure.

Mounting guide / Inductive Modem Coupler Detail
 (Note: Photo is 37-IMP; detail similar for 16plus-IM)

Guide is sized *slightly* bigger than specified cable diameter, to allow cable to pass through freely but limit vibration of 16plus-IM on cable

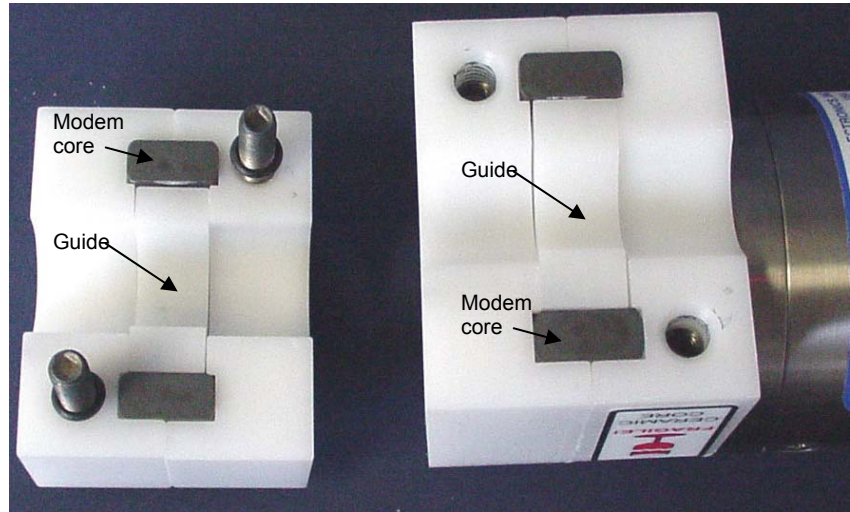

The SBE 16plus-IM is ready to go into the water.

System Installation and Wiring

For system installation and wiring details, refer to:

- *Mooring Cable and Wiring Requirements* in *Section 2: Description of SBE 16plus-IM*
- *Appendix IV: SIM Hookup and Configuration.*

Installing Optional Inductive Cable Coupler (ICC)

1. Loosen the titanium hex head bolts connecting the two halves of each of the ICC brackets. Pull the halves apart.
2. Place the insulated mooring cable inside the brackets' grooves.
3. Reinstall each bracket half with the hex bolts.
4. Verify that the two halves of the modem coupling toroid have come together evenly, and that the mounting clamp is secure.

Note:

See *Application Note 85: Handling of Ferrite Core on Instruments with Inductive Modem Telemetry* for more detailed information on handling and installation.

Mounting clamp, with opening sized to specified cable diameter – cable **clamped** by this bracket. Note: Installing clamp on larger cable than specified may cause damage to cable and/or modem and prevent IM communications.

Mounting guide / inductive modem coupler – contains modem coupling toroid. Cable goes through here but is **not clamped**, to avoid putting through tension on end cap (which could pull off end cap). **Detail of guide and core is similar to shown above for the 16plus-IM guide and core.**

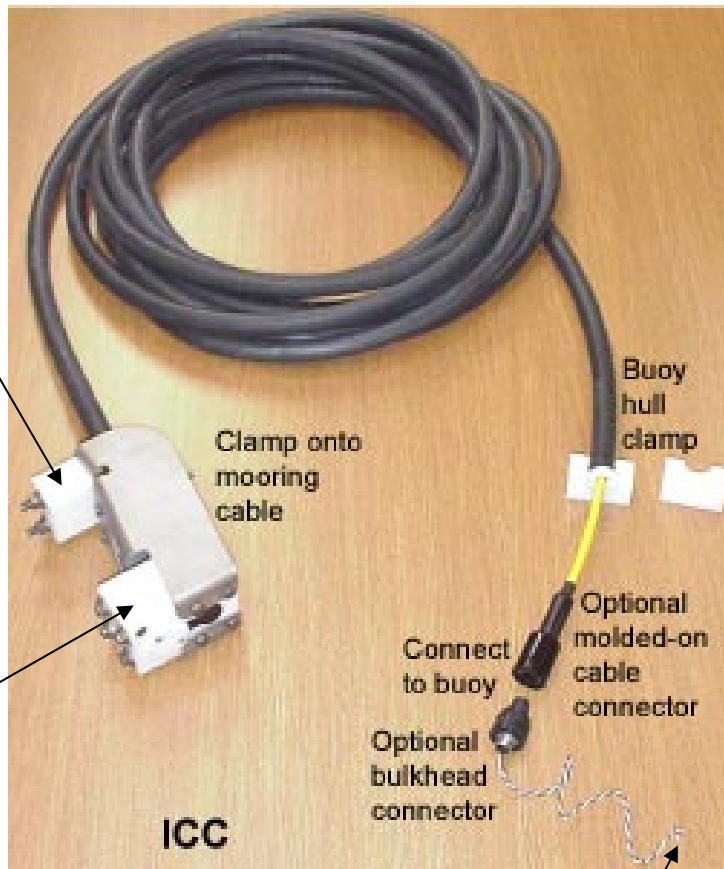

Wiring to SIM PCB

Recovery

WARNING!

If the 16plus-IM stops working while underwater, is unresponsive to commands, or shows other signs of flooding or damage, carefully secure it away from people until you have determined that abnormal internal pressure does not exist or has been relieved. Pressure housings may flood under pressure due to dirty or damaged o-rings, or other failed seals. When a sealed pressure housing floods at great depths and is subsequently raised to the surface, water may be trapped at the pressure at which it entered the housing, presenting a danger if the housing is opened before relieving the internal pressure. Instances of such flooding are rare. However, a housing that floods at 5000 meters depth holds an internal pressure of more than 7000 psia, and has the potential to eject the end cap with lethal force. A housing that floods at 50 meters holds an internal pressure of more than 85 psia; this force could still cause injury.

If you suspect the 16plus-IM is flooded, point the 16plus-IM in a safe direction away from people, and loosen 1 end cap bulkhead connector very slowly, at least 1 turn. This opens an o-ring seal under the connector. Look for signs of internal pressure (hissing or water leak). If internal pressure is detected, let it bleed off slowly past the connector o-ring. Then, you can safely remove the end cap.

Physical Handling

1. Rinse the instrument and conductivity cell with fresh water. (See *Section 5: Routine Maintenance and Calibration* for cell cleaning and storage.)
2. Reinsert the protective plugs in the anti-foulant device cups.
3. If the batteries are exhausted, new batteries must be installed before the data can be extracted. Stored data will not be lost as a result of exhaustion or removal of batteries. (See *Section 5: Routine Maintenance and Calibration* for replacement of batteries.)
4. If immediate redeployment is not required, it is best to leave the 16plus-IM with batteries in place and in a quiescent state (**PwrOff**). Because the quiescent current required is only 130 microamps, the batteries can be left in place without significant loss of capacity. If the 16plus-IM is to be stored for a long time, **replace the batteries yearly to prevent battery leakage** (which could damage the 16plus-IM).

Note:

Data may be uploaded during deployment or after recovery. If uploading after recovery:

1. Wire the 16plus-IM and SIM as described in *Section 3: Preparing for Deployment*.
2. Set Modem/RS485 ID (on COM Settings tab of SBE 16plus Configuration Options dialog box) to *Automatically get ID*.

If uploading during deployment: Leave Modem/RS485 ID on *Prompt ID*. SEATERM will prompt for the 16plus-IM ID when you use Toolbar or menu shortcuts for commands.

Uploading Data

1. Double click on SeaTerm.exe. The display shows the main screen.
2. In the Configure menu, select *SBE 16plus*. Click on the Upload Settings tab. The dialog box looks like this:

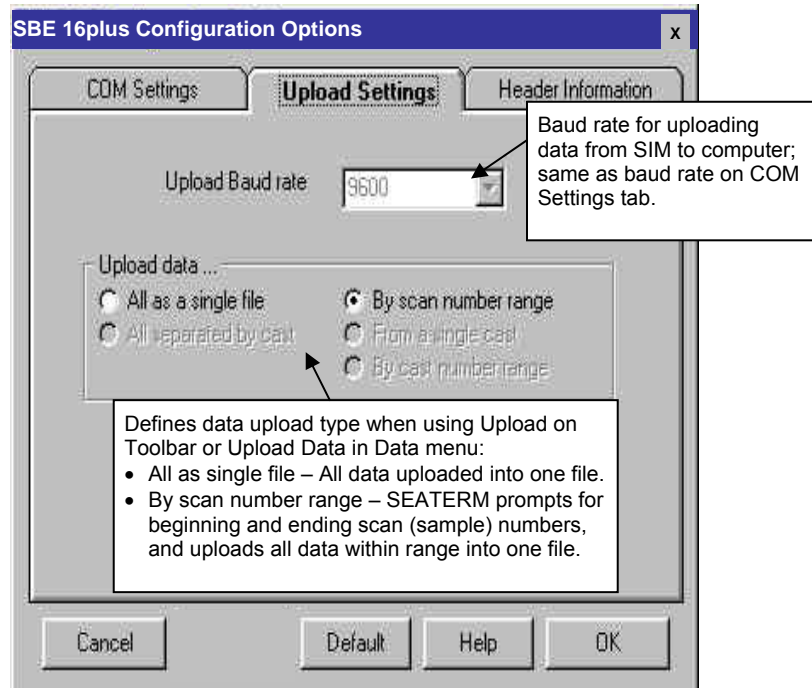

Make the selection for Upload Settings.

3. Click on the Header Information tab. The dialog box looks like this:

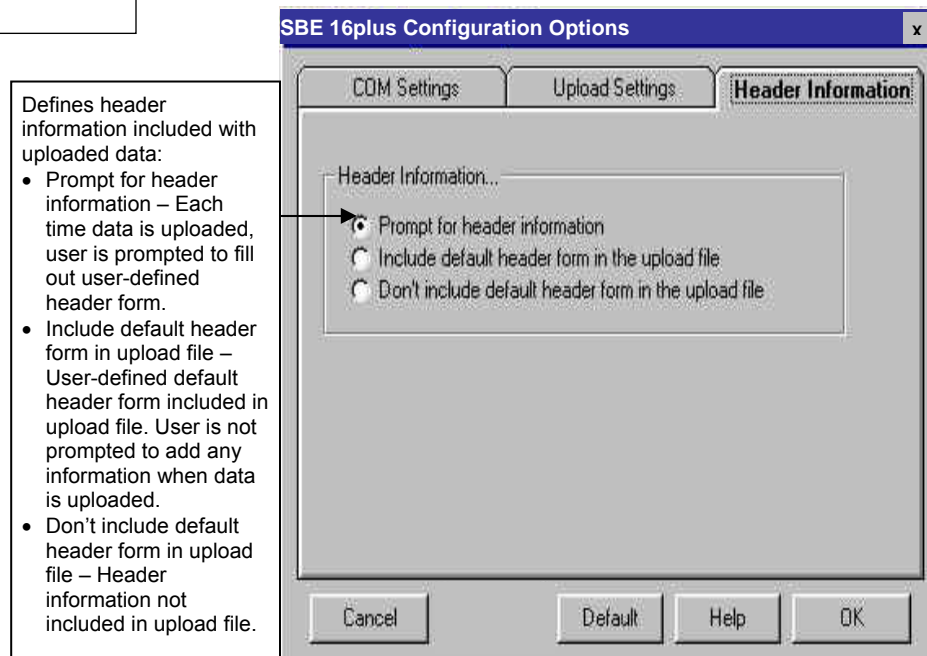

Select the desired header information option. Click OK to save the settings.

Note:

Set up **Upload Settings**, **Header Information**, and/or **Header Form** (Steps 2 through 4):

- The first time you upload data, and
- If you want to change upload or header parameters.

4. In the Configure menu, select Header Form to customize the header. The dialog box looks like this (default prompts are shown):

The entries are free form, 0 to 12 lines long. This dialog box establishes:

- the header prompts that appear for the user to fill in when uploading data, if *Prompt for header information* was selected in the Configuration Options dialog box (Step 3)
- the header included with the uploaded data, if *Include default header form in upload file* was selected in the Configuration Options dialog box (Step 3)

Enter the desired header/header prompts. Click OK.

5. Click Connect on the Toolbar to begin communications with the 16plus-IM. The display looks like this:

```
SBE 37 SURFACE MODEM V 2.8a
S>
Sending wake up tone, wait 4 seconds
S>
```

This shows that correct communications between the computer and the SIM has been established, and the SIM has sent the wake-up signal to the 16plus-IM(s).

If the system does not respond as shown above:

- Click Connect again.
 - Check cabling between the computer, SIM, and 16plus-IM.
 - Verify the correct instrument was selected and the COM settings were entered correctly in the Configure menu.
6. If you have not already done so, command the 16plus-IM to stop autonomous sampling by typing **#iStop** (ii= 16plus-IM ID) and pressing the Enter key.

Note:

The display shows SBE 37 because the SIM was originally developed for the SBE 37-IM MicroCAT.

7. Display 16plus-IM status information by clicking Status on the Toolbar. The display looks like this:

```
SBE 16plus-IM V 1.2a SERIAL NO. 4000 01 Mar 2006 14:02:13
vbatt = 9.6, vlith = 8.5, ioper = 61.2 ma, ipump = 25.5 ma
status = not logging
sample interval = 15 seconds, number of measurements per sample = 1
samples = 50004, free = 509234
run pump for 0.5 sec, delay before sampling = 0.0 seconds
battery cutoff = 7.5 volts
pressure sensor = strain gauge, range = 1000.0
SBE 38=no, Ext Volt 0=no, Ext Volt 1=no, Ext Volt 2=no, Ext Volt 3=no
output format = converted decimal
output sample number = yes, output salinity = no, output sound velocity = no
```

8. Click Upload on the Toolbar to upload stored data in a form that Sea-Bird's data processing software can use. SEATERM responds as follows before uploading the data:
- SEATERM sends **#iiOutputFormat=0** to set the output format to raw hexadecimal.
 - SEATERM sends the status (**#iiDS**), header (**#iiDH**), and calibration coefficients (**#iiDCal**) commands, displays the responses, and writes the commands and responses to the upload file. This provides you with information regarding the number of samples in memory, sample interval, headers, calibration coefficients, etc.
 - If you selected *By scan number range in the Configuration Options dialog box (Configure menu)*** – a dialog box requests the range. Enter the desired values, and click OK.
 - If you selected *Prompt for header information in the Configuration Options dialog box (Configure menu)*** – a dialog box with the header form appears. Enter the desired header information, and click OK. SEATERM writes the header information to the upload file.
 - In the Open dialog box, enter the desired upload file name and click OK. The upload file has a .hex extension.
 - SEATERM sends the data upload command (**#iiDDb,e**).
 - When the data has been uploaded, SEATERM shows the S> prompt.
9. Ensure all data has been uploaded from the 16plus-IM by reviewing and processing the data. Use **SBE Data Processing** to process and plot the data (see *Processing Data Using SBE Data Processing* and SBE Data Processing manual / Help files).

Note:

To prepare the 16plus-IM for re-deployment:

- After all data has been uploaded, send **#iilnitLogging**. If this command is not sent and logging is started, new data will be stored after the last recorded sample, preventing use of the entire memory capacity.
- Send **PwrOff** to put the 16plus-IM in quiescent (sleep) state until ready to redeploy. The quiescent current is only 130 microamps, so the batteries can be left in place without significant loss of capacity.

Processing Data Using SBE Data Processing

Notes:

- See the SBE Data Processing manual and/or Help files.
- When we ship a new instrument, we include a .con file that reflects the current instrument configuration as *we know it*. The .con file is named with the instrument serial number, followed with the .con extension. For example, for an instrument with serial number 2375, Sea-Bird names the .con file *2375.con*. You may rename the .con file if desired; this will not affect the results.
- In the 16plus-IM setup commands, external voltage numbers 0, 1, 2, and 3 correspond to wiring of sensors to a voltage channel on the end cap (see *Dimensions and End Cap Connectors* in Section 2: *Description of SBE 16plus-IM*). However, in the .con file, voltage 0 is the first external voltage in the data stream, voltage 1 is the second, etc.

1. Convert the .hex (raw data) file (uploaded from 16plus-IM memory) to a .cnv (engineering units) file in SBE Data Processing's Data Conversion module.
2. Once the data is converted: perform further processing (remove bad data, etc.), calculate derived variables, and plot data using SBE Data Processing's other modules.

Verifying Contents of Configuration (.con) File

To convert the .hex (raw data) file, you need a .con file, which defines the instrument – integrated sensors, and channels, serial numbers, and calibration dates and coefficients for all sensors (conductivity, temperature, and pressure as well as auxiliary sensors). SBE Data Processing uses the .con file information to interpret and process the raw data. **If the .con file does not match the actual instrument configuration, the software will be unable to interpret and process the data correctly.**

To view or modify the .con file:

1. Double click on SBEDataProc.exe.
2. In the Configure menu, select *SBE 16 Seacat plus CTD*. The configuration dialog box appears. In the configuration dialog box, click Open.
3. In the Open dialog box, select the appropriate .con file and click Open. Verify that the sensors match those on your 16plus-IM, and that auxiliary sensors are assigned to the correct voltage channels. Verify that calibration coefficients for all sensors are up-to-date.

Channel/Sensor table reflects this choice. Must agree with 16plus-IM setup for #iiVoltN= (N=0, 1, 2, and 3); see reply from #iiDS. Voltage channel 0 in .con file corresponds to first external voltage in data stream, voltage channel 1 to second external voltage in data stream, etc.

Interval between scans. Must agree with 16plus-IM setup (#iiSampleInterval=); see reply from #iiDS.

Not applicable to 16plus-IM.

Strain gauge, Digiquartz with temperature compensation, or none. If *no pressure sensor* is selected, Data button accesses dialog box to input additional parameter needed to process data. Must agree with 16plus-IM setup (#iiPType=); see reply from #iiDS. Note: Digiquartz without temperature compensation not applicable.

None or SBE 38 (secondary temperature). Must agree with 16plus-IM setup; see reply from #iiDS. Channel/Sensor table lists RS-232 sensor below voltage channels. Note: GTD and SBE 50 selections not applicable to 16plus-IM.

Shaded sensors cannot be removed or changed to another type of sensor. All others are optional.

New to create new .con file for this CTD. Open to select different .con file. Save or Save As to save current .con file settings.

Click a (non-shaded) sensor and click **Select** to pick a different sensor for that channel. A dialog box with a list of sensors appears. Select sensors after number of voltage channels have been specified above.

Click a sensor and click **Modify** to change calibration coefficients for that sensor.

Configuration for the SBE 16plus-IM

Configuration file opened: []

Pressure sensor type: Strain Gauge [Data...]

External voltage channels: 2

Serial RS-232C sensor: Temperature, SBE 38

Sample interval seconds: 10

NMEA position data added

Channel	Sensor	New
1. Count	Temperature	Open...
2. Frequency	Conductivity	Save
3. Count	Pressure, Strain Gauge	Save As
4. A/D voltage 0	Oxygen, SBE 43	Select...
5. A/D voltage 1	pH	Modify...
6. Serial RS-232	Temperature, SBE 38	

Report... Help... Exit Cancel

4. Click *Save* or *Save As* to save any changes to the .con file. Click *Exit* when done reviewing / modifying the .con file

Editing Raw Data File

Sometimes users want to edit the raw .hex data file before beginning processing, to remove data at the beginning of the file corresponding to instrument *soak* time, to remove blocks of bad data, to edit the header, or to add explanatory notes about the cast. **Editing the raw .hex file can corrupt the data, making it impossible to perform further processing using Sea-Bird software.** We strongly recommend that you first convert the data to a .cnv file (using Data Conversion in SBE Data Processing), and then use other SBE Data Processing modules to edit the .cnv file as desired.

Note:

Although we provide this technique for editing a raw .hex file, **Sea-Bird's strong recommendation, as described above, is to always convert the raw data file and then edit the converted file.**

The procedure for editing a .hex data file described below has been found to work correctly on computers running Windows 98, 2000, and NT. **If the editing is not performed using this technique, SBE Data Processing may reject the edited data file and give you an error message.**

1. **Make a back-up copy of your .hex data file before you begin.**
2. Run **WordPad**.
3. In the File menu, select Open. The Open dialog box appears. For *Files of type*, select *All Documents (*.*)*. Browse to the desired .hex data file and click Open.
4. Edit the file as desired, **inserting any new header lines after the System Upload Time line**. Note that all header lines must begin with an asterisk (*), and *END* indicates the end of the header. An example is shown below (for an SBE 21), with the added lines in bold:

```
* Sea-Bird SBE 21 Data File:
* FileName = C:\Odis\SAT2-ODIS\oct14-19\oct15_99.hex
* Software Version Seasave Win32 v1.10
* Temperature SN = 2366
* Conductivity SN = 2366
* System Upload Time = Oct 15 1999 10:57:19
* Testing adding header lines
* Must start with an asterisk
* Place anywhere between System Upload Time & END of header
* NMEA Latitude = 30 59.70 N
* NMEA Longitude = 081 37.93 W
* NMEA UTC (Time) = Oct 15 1999 10:57:19
* Store Lat/Lon Data = Append to Every Scan and Append to .NAV
File When <Ctrl F7> is Pressed
** Ship:          Sea-Bird
** Cruise:        Sea-Bird Header Test
** Station:
** Latitude:
** Longitude:
*END*
```
5. In the File menu, select Save (**not Save As**). If you are running Windows 2000, the following message displays:
You are about to save the document in a Text-Only format, which will remove all formatting. Are you sure you want to do this?
Ignore the message and click *Yes*.
6. In the File menu, select Exit.

Section 5: Routine Maintenance and Calibration

This section reviews:

- corrosion precautions
- connector mating and maintenance
- battery replacement
- conductivity cell storage and cleaning
- pressure sensor maintenance
- AF24173 Anti-Foulant Device replacement
- sensor calibration

The accuracy of the SBE 16*plus*-IM is sustained by the care and calibration of the sensors and by establishing proper handling practices.

Corrosion Precautions

Rinse the SBE 16*plus*-IM with fresh water after use and prior to storage.

For both the plastic and titanium housing, all exposed metal is titanium (the plastic housing has a titanium end cap). No corrosion precautions are required, but direct electrical connection of the titanium to dissimilar metal hardware should be avoided.

Connector Mating and Maintenance

Note:

See *Application Note 57: Connector Care and Cable Installation*.

Clean and inspect connectors, cables, and dummy plugs before every deployment and as part of your yearly equipment maintenance. Inspect connectors that are unmated for signs of corrosion product around the pins, and for cuts, nicks or other flaws that may compromise the seal.

When remating:

CAUTION:

Do not use WD-40 or other petroleum-based lubricants, as they will damage the connectors.

1. Lightly lubricate the inside of the dummy plug/cable connector with silicone grease (DC-4 or equivalent).
2. **Standard Connector** - Install the plug/cable connector, aligning the raised bump on the side of the plug/cable connector with the large pin (pin 1 - ground) on the 16*plus*-IM. Remove any trapped air by *burping* or gently squeezing the plug/connector near the top and moving your fingers toward the end cap. **OR**
MCBH Connector – Install the plug/cable connector, aligning the pins.
3. Place the locking sleeve over the plug/cable connector. Tighten the locking sleeve finger tight only. **Do not overtighten the locking sleeve and do not use a wrench or pliers.**

Verify that a cable or dummy plug is installed for each connector on the system before deployment.

Replacing Alkaline Batteries

Alkaline D-cell
(MN1300, LR20)



Screws securing end cap
(shown partially removed)

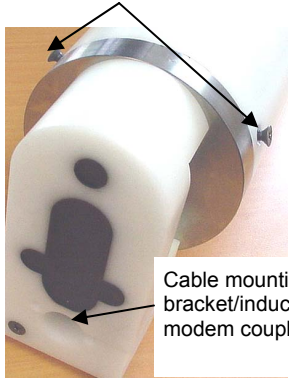

Cable mounting
bracket/inductive
modem coupler

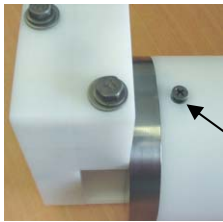

Screw securing
end cap (shown
partially removed)

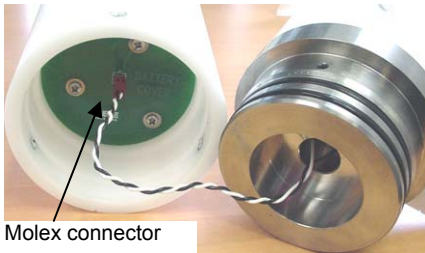

Molex connector

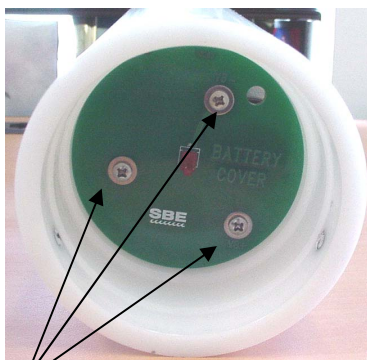

Remove Phillips-head screws
and washers from battery cover plate

The SBE 16*plus*-IM uses alkaline D-cells (Duracell MN1300, LR20), dropped into the battery compartment.

Leave the batteries in place when storing the SBE 16*plus*-IM to prevent depletion of the back-up lithium batteries by the real-time clock. Even *exhausted* main batteries will power the clock almost indefinitely. If the 16*plus*-IM is to be stored for long periods, **replace the batteries yearly to prevent battery leakage** (which could damage the 16*plus*-IM).

1. Remove the modem end cap (end cap without connectors):
 - A. Wipe the outside of the end cap and housing dry, being careful to remove any water at the seam between them.
 - B. Remove the three flat Phillips-head screws. Do not remove any other screws from the housing.
 - C. Remove the end cap by pulling firmly and steadily on the plastic cable mounting bracket/inductive modem coupler. It may be necessary to twist or rock the end cap back and forth or use a non-marring tool on the edge of the cap to loosen it.
 - D. The end cap is electrically connected to the electronics with a 2-pin Molex connector. Holding the wire cluster near the connector, pull gently to detach the female end of the connector from the pins.
 - E. Remove any water from the O-ring mating surfaces inside the housing with a lint-free cloth or tissue.
 - F. Put the end cap aside, being careful to protect the O-rings from damage or contamination.
2. Remove the battery cover plate from the housing:
 - A. Remove the three Phillips-head screws and washers from the battery cover plate inside the housing.
 - B. The battery cover plate will pop out. Put it aside.
3. Turn the 16*plus*-IM over and remove the batteries.
4. Install the new batteries, with the + terminals against the flat battery contacts and the - terminals against the spring contacts.
5. Reinstall the battery cover plate in the housing:
 - A. Align the battery cover plate with the housing. The posts inside the housing are not placed symmetrically, so the cover plate fits into the housing only one way. Looking at the cover plate, note that one screw hole is closer to the edge than the others, corresponding to the post that is closest to the housing.
 - B. Reinstall the three Phillips-head screws and washers, while pushing hard on the battery cover plate to depress the spring contacts at the bottom of the battery compartment. **The screws must be fully tightened, or battery power to the circuitry will be intermittent.**
6. Check the battery voltage at BAT + and BAT - on the battery cover plate. It should be approximately 13.5 volts.
7. Reinstall the end cap:
 - A. Remove any water from the O-rings and mating surfaces with a lint-free cloth or tissue. Inspect the O-rings and mating surfaces for dirt, nicks, and cuts. Clean or replace as necessary. Apply a light coat of o-ring lubricant (Parker Super O Lube) to O-rings and mating surfaces.
 - B. Plug the female end of the 2-pin Molex connector onto the pins. Verify the connector is properly aligned - a backward connection will prevent communication with the computer.
 - C. Carefully fit the end cap into the housing until the O-rings are fully seated.
 - D. Reinstall the three flat Phillips-head screws to secure the end cap.

Conductivity Cell Maintenance

CAUTIONS:

- **Do not put a brush or any object inside the conductivity cell to dry it or clean it.** Touching and bending the electrodes can change the calibration. Large bends and movement of the electrodes can damage the cell.
- **Do not store the 16plus-IM with water in the conductivity cell.** Freezing temperatures (for example, in Arctic environments or during air shipment) can break the cell if it is full of water.

The SBE 16plus-IM's conductivity cell is shipped dry to prevent freezing in shipping. Refer to *Application Note 2D: Instructions for Care and Cleaning of Conductivity Cells* for conductivity cell cleaning procedures and cleaning materials.

- The Active Use (after each cast) section of the application note is not applicable to the 16plus-IM, which is intended for use as a moored instrument.

The 16plus-IM is shipped with a kit for cell filling and storage. The kit includes a syringe and tubing assembly, and two anti-foulant device caps with hose barbs. The tubing cannot attach to an anti-foulant device cap that is not barbed.

- If your 16plus-IM does not include a pump - the installed anti-foulant device caps at both ends of the conductivity cell are not barbed.
- If your 16plus-IM includes a pump - the installed anti-foulant device cap at the pump end of the cell is barbed; the installed anti-foulant device cap at the intake end of the cell is not barbed.

Unscrew cap, and replace with barbed cap for cleaning and storage

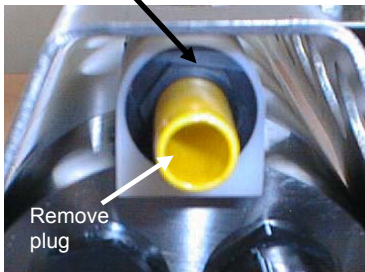

Cleaning and storage instructions below require use of the syringe and tubing assembly at the intake end of the cell (requiring one barbed cap), and looping Tygon tubing from end to end of the cell (requiring two barbed caps). Remove the installed anti-foulant device cap(s) and replace them with the anti-foulant device cap(s) with hose barbs **for cleaning and storage only**. Remember to reinstall the original anti-foulant device cap(s) before deployment. **Deploying an SBE 16plus-IM with barbed anti-foulant device cap(s) in place of the installed caps is likely to produce undesirable results in your data.** See *Replacing Anti-Foulant Devices* for safety precautions when handling the AF24173 Anti-Foulant Devices.

Pressure Sensor (optional) Maintenance

CAUTION:

Do not put a brush or any object in the pressure port. Doing so may damage or break the pressure sensor.

Pressure sensor maintenance varies, depending on the type of pressure sensor in your SBE 16*plus*-IM.

Strain Gauge Pressure Sensor

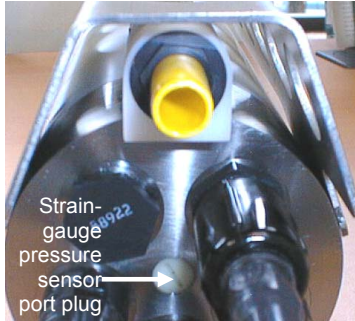

The pressure port plug has a small vent hole to allow hydrostatic pressure to be transmitted to the pressure sensor inside the instrument, while providing protection for the pressure sensor, keeping most particles and debris out of the pressure port.

Periodically (approximately once a year) inspect the pressure port to remove any particles, debris, etc:

1. Unscrew the pressure port plug from the pressure port.
2. Rinse the pressure port with warm, de-ionized water to remove any particles, debris, etc.
3. Replace the pressure port plug.

Quartz Pressure Sensor



Nylon pressure capillary fitting for 16*plus*-IM with Quartz pressure sensor

At the factory, the pressure sensor and pressure port were filled with a silicon oil, and a nylon pressure capillary fitting – which includes a pressure port fitting and an external capillary tube – were used to retain the oil. The oil transmits hydrostatic pressure via internal, stainless steel, capillary tubing to the pressure sensor inside the instrument, and prevents corrosion that might occur if the sensor diaphragm was exposed to water. The internal tubing and nylon capillary fitting are vacuum back-filled at the factory.

Because of the viscosity of the silicone oil and capillary action, the silicone oil does not run out of the external capillary tube. However, due to temperature and pressure cycling over long periods, it is normal for some oil to slowly leak out of the external capillary tube. **When the oil is not visible or is receding inside the translucent tube, or if the fitting has been damaged, refill the oil** using the supplied pressure sensor oil refill kit. See *Application Note 12-1: Pressure Port Oil Refill Procedure & Nylon Capillary Fitting Replacement*.

Pump (optional) Maintenance

See *Application Note 75: Maintenance of SBE 5T, 5P, and 5M Pumps*.

Replacing Anti-Foulant Devices (SBE 16*plus*, SBE 19*plus*)



AF24173
Anti-Foulant
Device

The SBE 16*plus* and 19*plus* (moored option) have an anti-foulant device cup and cap on each end of the conductivity cell. A new SBE 16*plus* (or moored option 19*plus*) is shipped with an Anti-Foulant Device and a protective plug pre-installed in each cup.

Wearing rubber or latex gloves, follow this procedure to replace each Anti-Foulant Device (two):

1. Remove the protective plug;
2. Unscrew the cap with a 5/8-inch socket wrench;
3. Remove the old Anti-Foulant Device. If the old Anti-Foulant Device is difficult to remove:
 - Use needle-nose pliers and carefully break up material;
 - If necessary, remove the conductivity cell guard to provide easier access;
4. Place the new Anti-Foulant Device in the cup;
5. Rethread the cap onto the cup. Do not over tighten;
6. Replace the protective plug if not ready to redeploy.

WARNING!

AF24173 Anti-Foulant Devices contain bis(tributyltin) oxide. Handle the devices only with rubber or latex gloves. Wear eye protection. Wash with soap and water after handling.

Read precautionary information on product label (see Appendix V) before proceeding.

It is a violation of US Federal Law to use this product in a manner inconsistent with its labeling.

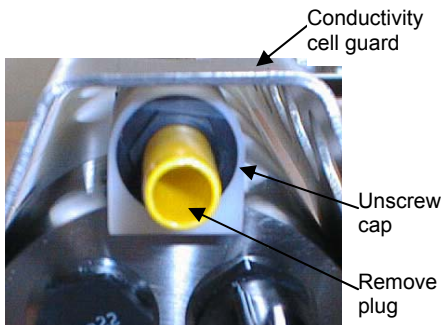

CAUTION:

One of the anti-foulant device cups is attached to the guard and connected to the conductivity cell. **Removing the guard without disconnecting the cup from the guard will break the cell.** If the guard must be removed:

1. Remove the two screws connecting the anti-foulant device cup to the guard;
2. Remove the four Phillips-head screws connecting the guard to the housing and sensor end cap;
3. Gently lift the guard away.

Sensor Calibration

Note

After recalibration, Sea-Bird enters the new calibration coefficients in the 16*plus*-IM EEPROM, and ships the instrument back to the user with Calibration Certificates showing the new coefficients. The user must enter the coefficients in the instrument configuration (.con) file in SBE Data Processing's Configure menu.

Sea-Bird sensors are calibrated by subjecting them to known physical conditions and measuring the sensor responses. Coefficients are then computed, which may be used with appropriate algorithms to obtain engineering units. The conductivity, temperature, and (optional) pressure sensors on the SBE 16*plus*-IM are supplied fully calibrated, with coefficients stored in EEPROM in the 16*plus*-IM and printed on their respective Calibration Certificates.

We recommend that the 16*plus*-IM be returned to Sea-Bird for calibration.

Conductivity Sensor

The conductivity sensor incorporates a fixed precision resistor in parallel with the cell. When the cell is dry and in air, the sensor's electrical circuitry outputs a frequency representative of the fixed resistor. This frequency is recorded on the Calibration Certificate and should remain stable (within 1 Hz) over time.

The primary mechanism for calibration drift in conductivity sensors is the fouling of the cell by chemical or biological deposits. Fouling changes the cell geometry, resulting in a shift in cell constant.

Accordingly, the most important determinant of long-term sensor accuracy is the cleanliness of the cell. We recommend that the conductivity sensors be calibrated before and after deployment, but particularly when the cell has been exposed to contamination by oil slicks or biological material.

Temperature Sensor

The primary source of temperature sensor calibration drift is the aging of the thermistor element. Sensor drift will usually be a few thousandths of a degree during the first year, and less in subsequent intervals. Sensor drift is not substantially dependent upon the environmental conditions of use, and — unlike platinum or copper elements — the thermistor is insensitive to shock.

Pressure Sensor

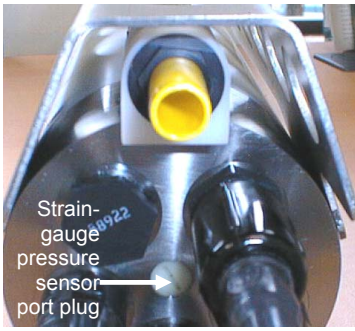

The SBE 16*plus*-IM is available with a strain-gauge pressure sensor or Quartz pressure sensor. These sensors are capable of meeting the 16*plus*-IM error specification with some allowance for aging and ambient-temperature induced drift.

Pressure sensors show most of their error as a linear offset from zero. A technique is provided below for making small corrections to the pressure sensor calibration using the *offset* (**#iiPOffset=**) calibration coefficient term by comparing 16*plus*-IM pressure output to readings from a barometer.

Allow the 16*plus*-IM to equilibrate in a reasonably constant temperature environment for at least 5 hours before starting. Pressure sensors exhibit a transient change in their output in response to changes in their environmental temperature. Sea-Bird instruments are constructed to minimize this by thermally decoupling the sensor from the body of the instrument. However, there is still some residual effect; allowing the 16*plus*-IM to equilibrate before starting will provide the most accurate calibration correction.

Note:

The pressure sensor is an absolute sensor, so its **raw** output includes the effect of atmospheric pressure (14.7 psi). As shown on the Calibration Sheet, Sea-Bird's calibration (and resulting calibration coefficients) is in terms of psia. However, when outputting pressure in **engineering units**, the 16*plus*-IM outputs pressure relative to the ocean surface (i.e., at the surface the output pressure is 0 decibars).

The 16*plus*-IM uses the following equation to convert psia to decibars:
 pressure (db) =
 [pressure (psia) - 14.7] * 0.689476

1. Place the 16*plus*-IM in the orientation it will have when deployed.
2. In SEATERM:
 - A. Set the pressure offset to 0.0 (**#iiPOffset=0**).
 - B. Send **#iiTP** to measure the 16*plus*-IM pressure 100 times and transmit converted data in engineering units (decibars).
3. Compare the 16*plus*-IM output to the reading from a good barometer at the same elevation as the 16*plus*-IM pressure sensor.
 Calculate *offset* = barometer reading – 16*plus*-IM reading
4. Enter the calculated offset (positive or negative) in two places:
 - In the 16*plus*-IM EEPROM, using **#iiPOffset=** in SEATERM, **and**
 - In the configuration (.con) file, using SBE Data Processing.

Offset Correction Example

Absolute pressure measured by a barometer is 1010.50 mbar. Pressure displayed from 16*plus*-IM is -2.5 dbars.

Convert barometer reading to dbars using the relationship: mbar * 0.01 = dbar

Barometer reading = 1010.50 mbar * 0.01 = 10.1050 dbar

The 16*plus*-IM's internal calculations and our processing software output gage pressure, using an assumed value of 14.7 psi for atmospheric pressure. Convert 16*plus*-IM reading from gage to absolute by adding 14.7 psia to the 16*plus*-IM output:

$-2.5 \text{ dbars} + (14.7 \text{ psi} * 0.689476 \text{ dbar/psia}) = -2.5 + 10.13 = 7.635 \text{ dbars}$

Offset = 10.1050 – 7.635 = + 2.47 dbars

Enter offset in 16*plus*-IM and in .con file.

For demanding applications, or where the sensor's air ambient pressure response has changed significantly, calibration using a dead-weight generator is recommended. The end cap's $\frac{7}{16}$ -20 straight thread permits mechanical connection to the pressure source. Use a fitting that has an O-ring tapered seal, such as Swagelok-200-1-4ST, which conforms to MS16142 boss.

Section 6: Troubleshooting

This section reviews common problems in operating the SBE 16*plus*-IM, and provides the most common causes and solutions.

Problem 1: Unable to Communicate with SBE 16*plus*-IM

The `S>` prompt indicates that communications between the SBE 16*plus*-IM and computer have been established. Before proceeding with troubleshooting, attempt to establish communications again by clicking Connect on SEATERM's toolbar or pressing the Enter key several times.

Cause/Solution 1: The I/O cable connection may be loose. Check the cabling between the SIM and computer for a loose connection.

Cause/Solution 2: The instrument type and/or its communication settings may not have been entered correctly in SEATERM. Select the *SBE 16plus* in the Configure menu and verify the settings in the Configuration Options dialog box. The settings should match those on the instrument Configuration Sheet.

Cause/Solution 3: The I/O cable between the SIM and computer may not be the correct one. The I/O cable supplied with the SIM permits connection to standard 9-pin RS-232 interfaces.

Cause/Solution 4: The modem core in the 16*plus*-IM (and/or the ICC, if applicable) may have a gap, be misaligned, or be damaged. See *Application Note 85: Handling of Ferrite Core in Instruments with Inductive Modem Telemetry* for details on inspecting the modem core and proper installation of the 16*plus*-IM and the ICC (if applicable) on the cable.

Problem 2: No Data Recorded

Cause/Solution 1: The memory may be full; once the memory is full, no further data will be recorded. Verify that the memory is not full using `#iDS` (*free* = 0 or 1 if memory is full). Sea-Bird recommends that you upload all previous data before beginning another deployment. Once the data is uploaded, send `#iiInitLogging` to reset the memory. After the memory is reset, `#iDS` will show *samples* = 0.

Problem 3: Nonsense or Unreasonable Data

The symptom of this problem is an uploaded file that contains nonsense values (for example, 9999.999) or unreasonable values (for example, values that are outside the expected range of the data).

Cause/Solution 1: An uploaded data file with nonsense values may be caused by incorrect instrument configuration:

- Bad data may be caused by incorrect configuration in the 16*plus*-IM. Send **#iiDS** to verify the setup of the 16*plus*-IM matches the instrument Configuration Sheet (correct pressure sensor, voltage sensors assigned to correct channels, etc).
- Bad data may be caused by incorrect configuration in the instrument .con file. Verify the settings in the instrument .con file match the instrument Configuration Sheet.

Note:

Each 16*plus*-IM is shipped with a configuration (.con) file that matches the configuration of the instrument (number and type of auxiliary sensors, etc.) and includes the instrument calibration coefficients.

Cause/Solution 2: An uploaded data file with unreasonable (i.e., out of the expected range) values for temperature, conductivity, etc. may be caused by incorrect calibration coefficients:

- If you uploaded data in engineering units (**#iiOutputFormat=1** or **3**) – Bad data may be caused by incorrect calibration coefficients in the 16*plus*-IM. Send **#iiDCal** to verify the calibration coefficients in the 16*plus*-IM match the instrument Calibration Certificates. Note that calibration coefficients do not affect the raw data stored in 16*plus*-IM memory. If you have not yet overwritten the memory with new data, you can correct the coefficients and then upload the data again.
- If you uploaded data in raw hexadecimal (**#iiOutputFormat=0**) and are processing the data in SBE Data Processing - Bad data may be caused by incorrect calibration coefficients in the instrument .con file. Verify the calibration coefficients in the .con file match the instrument Calibration Certificates.
- For SBE 38 RS-232 sensor interfacing to the 16*plus*-IM: Bad data may be caused by incorrect calibration coefficients programmed into the SBE 38. Connect the instrument directly to the computer to verify the calibration coefficients match the instrument Calibration Certificate.

Problem 4: Program Corrupted

Note:

Using the reset switch does not affect the 16*plus*-IM memory - data in memory and user-programmable parameter values are unaffected.

Cause/Solution 1: In rare cases, a severe static shock or other problem can corrupt the program that controls the SBE 16*plus*-IM microprocessor. This program can be initialized by using the reset switch. Proceed as follows to initialize:

1. Open the battery end cap and remove the batteries (see *Replacing Alkaline Batteries* in *Section 5: Routine Maintenance and Calibration*).
2. There is a small, pushbutton switch on the battery compartment bulkhead, which is visible after the batteries are removed. The switch is used to disconnect the internal back-up lithium batteries from the electronics. Push the switch in for 1 second.
3. Reinstall or replace the batteries, and close the battery end cap.
4. Establish communications with the 16*plus*-IM (see *Section 3: Preparing for Deployment*). Send **#iiDS** to verify that the date and time and sample number are correct.

Glossary

Batteries – Nine alkaline D-cells (Duracell MN1300, LR20) standard.

Fouling – Biological growth in the conductivity cell during deployment.

ICC – Inductive Cable Coupler, which clamps to the insulated mooring cable and transfers the inductive signal on wire to the SIM PCB installed inside the buoy or elsewhere.

PCB – Printed Circuit Board.

SBE Data Processing – Sea-Bird's 2000/XP data processing software, which calculates and plots temperature, conductivity, and optional pressure, data from auxiliary sensors, and derives variables such as salinity and sound velocity.

Scan – One data sample containing temperature, conductivity, optional pressure, date and time, and optional auxiliary inputs.

SEACAT – High-accuracy conductivity, temperature, and pressure recorder. The SEACAT is available as the SBE 16*plus* (moored applications), and SBE 19*plus* (moored or profiling applications). A *plus* version of the SBE 21 (thermosalinograph) is under development.

The 16*plus* is available in three versions:

- 16*plus* with **RS-232** interface (standard)
- 16*plus* with **RS-485** interface
- 16*plus*-IM with **inductive modem** interface (this manual)

SEASAVE V7 – Sea-Bird's Win 2000/XP software used to acquire, convert, and display real-time or archived raw data. **SEASAVE cannot be used to acquire data from the 16*plus*-IM, but can be used to display in engineering units the raw hexadecimal data uploaded from the 16*plus*-IM.**

SEASOFT-Win32– Sea-Bird's complete Win 2000/XP software package, which includes software for communication, real-time data acquisition, and data analysis and display. SEASOFT-Win32 includes *SEATERM*, *SBE Data Processing*, *SEASAVE V7*.

SEATERM – Sea-Bird's Win 95/98/NT/2000/XP terminal program used to communicate with the SBE 16*plus*-IM.

SIM – Surface Inductive Modem PCB, used to interface between computer serial port and SBE 16*plus*-IM or other IM-compatible sensors.

TCXO – Temperature Compensated Crystal Oscillator.

Triton X-100 – Reagent grade non-ionic surfactant (detergent), used for cleaning the conductivity cell. Triton can be ordered from Sea-Bird, but should also be available locally from chemical supply or laboratory products companies. Triton is manufactured by Mallinckrodt Baker (see <http://www.mallbaker.com/changecountry.asp?back=/Default.asp> for local distributors)

Appendix I: Functional Description and Circuitry

Sensors

The SBE16*plus*-IM embodies the same sensor elements (three-electrode, two-terminal, borosilicate glass cell, and pressure-protected thermistor) previously employed in Sea-Bird's modular SBE 3 and SBE 4 sensors and in the original SEACAT design. The SBE 16*plus*-IM differs from the SBE 16 in that it uses three independent channels to digitize temperature, conductivity, and pressure concurrently. Multiplexing is not used for these channels.

The optional internally mounted pressure sensor is a Druck strain-gauge sensor or Quartz sensor.

Sensor Interface

Temperature is acquired by applying an AC excitation to a bridge circuit containing an ultra-stable aged thermistor with a drift rate of less than 0.002 °C per year. The other elements in the bridge are VISHAY precision resistors. A 24-bit A/D converter digitizes the output of the bridge. AC excitation and ratiometric comparison avoids errors caused by parasitic thermocouples, offset voltages, leakage currents, and reference errors.

Conductivity is acquired using an ultra-precision Wein-Bridge oscillator to generate a frequency output in response to changes in conductivity.

Strain-gauge pressure is acquired by applying an AC excitation to the pressure bridge. A 24-bit A/D converter digitizes the output of the bridge. AC excitation and ratiometric comparison avoids errors caused by parasitic thermocouples, offset voltages, leakage currents, and reference errors. A silicon diode embedded in the pressure bridge is used to measure the temperature of the pressure bridge. This temperature is used to perform offset and span corrections on the measured pressure signal.

The four external 0 to 5 volt DC voltage channels are processed by differential amplifiers with an input resistance of 50K ohms and are digitized with a 14-bit A/D converter.

Real-Time Clock

To minimize power and improve clock accuracy, a temperature-compensated crystal oscillator (TCXO) is used as the real-time-clock frequency source. The TCXO is accurate to ± 1 minute per year (0 °C to 40 °C).

Battery Wiring

SBE 16*plus*-IM main battery is a series connection of D-cells that drop into the battery compartment as a cluster of end-to-end stacks, three batteries each (standard 9-cell battery pack has three stacks). The positive battery connections are contact areas on double-thick printed circuit disks that form the internal bulkhead and battery retainer plates. Battery negative contacts are heavy beryllium-copper springs. The three cell stacks are aligned by plastic insulated aluminum spacers which also serve as electrical interconnects. The battery-to-circuit card connection is made by means of a Molex-type 3-pin pc board connector (JP3 on the power PCB).

The Power PCB contains three series-connected Panasonic BR-2/3A lithium cells (non-hazardous) which are diode OR'd with the main battery. The back-up lithium supply is capable of maintaining the buffer and the real-time clock if the main batteries are removed. If the back-up lithium battery voltage (*V_{lith}* in the #iDS response) falls below 7 volts, replace the back-up batteries.

Appendix II: Electronics Disassembly/Reassembly

CAUTION:

Use caution during disassembly and reassembly to avoid breaking the conductivity cell.

Disassembly

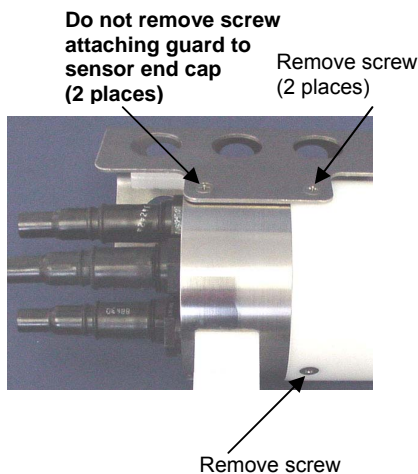

1. As a precaution, upload any data in memory before beginning.
2. Remove the two Phillips-head screws holding the conductivity cell guard to the housing. **Do not remove the two screws holding the conductivity cell guard to the sensor end cap.**
3. Remove the Phillips-head screw holding the sensor end cap to the housing on the side opposite the conductivity cell guard.
4. Remove the sensor end cap (with attached conductivity cell and cell guard) and electronics:
 - A. Wipe the outside of the sensor end cap and housing dry, being careful to remove any water at the seam between them.
 - B. Slide the end cap and attached electronics out of the housing.
 - C. The electronics are electrically connected to the battery compartment bulkhead with a Molex connector. Disconnect the Molex connector.
 - D. Remove any water from the O-rings and mating surfaces inside the housing with a lint-free cloth or tissue.
 - E. Be careful to protect the O-rings from damage or contamination.

Reassembly

Note:

Before delivery, a desiccant package is placed in the electronics chamber, and the electronics chamber is filled with dry Argon gas. These measures help prevent condensation.

If the electronics are exposed to the atmosphere, dry gas backfill with Argon and replace the desiccant package.

See *Application Note 71: Desiccant Use and Regeneration (drying)* for desiccant information.

Battery replacement does not affect desiccation of the electronics, as no significant gas exchange is possible unless the electronics PCBs are actually removed from the housing.

1. Reinstall the sensor end cap, conductivity cell and guard, and electronics:
 - A. Remove any water from the O-rings and mating surfaces in the housing with a lint-free cloth or tissue. Inspect the O-rings and mating surfaces for dirt, nicks, and cuts. Clean or replace as necessary. Apply a light coat of O-ring lubricant (Parker Super O Lube) to the O-rings and mating surfaces.
 - B. Plug the Molex connector onto the pins on the battery compartment bulkhead. Verify the connector holes and pins are properly aligned.
 - C. Carefully fit the end cap and electronics into the housing until the O-rings are fully seated.
2. Reinstall the three screws to secure the end cap.
3. Reset the date and time (`#iiMMDDYY=` and `#iiHHMMSS=`) and initialize logging (`#iiInitLogging`) before redeploying. No other parameters should have been affected by the electronics disassembly (send `#iiDS` to verify).

Appendix III: Command Summary

Note:
See *Command Descriptions* in Section 4: *Deploying and Operating SBE 16plus-IM* for detailed information and examples.

FUNCTION	CATEGORY	COMMAND	DESCRIPTION
SIM Commands	-	PwrOn	Send wakeup tone to all 16plus-IMs.
		PwrOff	Send power off command to all 16plus-IMs. SBE 16plus-IMs enter quiescent (sleep) state. Main power turned off, but data logging and memory retention unaffected.
		DS	Display SIM firmware version and setup parameters.
		Baud=x	x = baud rate between SIM and computer/controller (1200, 2400, 4800, or 9600). Default 9600.
		DataNNMax=x	x = timeout (milliseconds) that applies to Dataii only. If no reply received within x (0-32767), control returned to computer and other commands can be sent. Default 1000 milliseconds.
		RelayMax=x	x = timeout (seconds) that applies to all other commands. If no reply received within x (0-3276), control returned to computer and other commands can be sent. Default 20 seconds.
		EchoOn	Echo characters received from computer (default).
		EchoOff	Do not echo characters.
SBE 16plus-IM Communication Microcontroller Commands	Global	GData	Command all 16plus-IM communication microcontrollers to get last data sample from acquisition units. SBE 16plus-IM communication microcontrollers hold data in a buffer until receiving Dataii .
		MMDDYY=mmddy	Set real-time clock month, day, year for all 16plus-IMs. Follow with HHMMSS= or it will not set date.
		DDMMYY=ddmmyy	Set real-time clock day, month, year for all 16plus-IMs. Follow with HHMMSS= or it will not set date.
		HHMMSS=hmmss	Set real-time clock hour, minute, second for all 16plus-IMs.
	Get Data	Dataii	Get data obtained with GData from 16plus-IM with ID= ii .
	16plus-IM ID Only 1 16plus-IM can be on line when sending these commands.	ID?	Display 16plus-IM ID (ID= ii , where ii =0 to 99)
	16plus-IM communication microcontroller firmware version	*ID=ii (If more than 1 16plus-IM on line when setting ID, all will have same ID)	Set 16plus-IM ID to ii (ii =0 to 99). Command must be sent twice, because computer responds by requesting verification.
	!iiDS	Display firmware version.	

FUNCTION	CATEGORY	COMMAND	DESCRIPTION
SBE 16plus-IM Acquisition Microcontroller Commands (ii = SBE 16plus-IM ID)	Status	#iiDS	Display status and setup parameters.
	General Setup	#iiMMDDYY=mmddy	Set real-time clock month, day, year. Follow with #iiHHMMSS= or it will not set date.
		#iiDDMMYY=ddmmy	Set real-time clock day, month, year. Follow with #iiHHMMSS= or it will not set date.
		#iiHHMMSS=hmmss	Set real-time clock hour, minute, second.
		#iiMooredPumpMode=x	x=0: No pump. x=1: Run pump for 0.5 seconds before each sample. x=2: Run pump during each sample.
		#iiNCycles=x	x= number of measurements to take and average every #iiSampleInterval seconds. Default = 1.
		#iiInitLogging	After all previous data has been uploaded, send this command before starting to sample to make entire memory available for recording. If not sent, data stored after last sample. Equivalent to #iiSampleNumber=0.
		#iiSampleNumber=x	x= sample number for first sample when logging begins. After all previous data has been uploaded, set to 0 before starting to sample to make entire memory available for recording. If not set to 0, data stored after last sample. Equivalent to #iiInitLogging.
		#iiHeaderNumber=x	x= header number for first header when logging begins.
	Pressure Sensor Setup	#iiFlashInit	Map bad blocks and erase FLASH memory, which destroys all data in 16plus-IM.
		#iiPType=x	Pressure sensor type - x=0: No pressure sensor. x=1: Strain gauge. x=3: Quartz with temperature compensation.
	Voltage Sensor Setup	#iiRefPress=x	x= gauge reference pressure (db) to use if 16plus-IM does not include pressure sensor.
		#iiVolt0=x	x=Y: Enable external voltage 0. x=N: Do not enable external voltage 0.
		#iiVolt1=x	x=Y: Enable external voltage 1. x=N: Do not enable external voltage 1.
		#iiVolt2=x	x=Y: Enable external voltage 2. x=N: Do not enable external voltage 2.
		#iiVolt3=x	x=Y: Enable external voltage 3. x=N: Do not enable external voltage 3.
		#iiDelayBeforeSampling=x	x= time (seconds) to wait after switching on external voltage before sampling (0-32,000 seconds). Default 0 seconds.
	RS-232 Sensor Setup	#iiBiowiper=x	x=Y: Configuration includes ECO-FL fluorometer with Bio-Wiper. x=N (default): Does not.
		#iiSBE38=x	x=Y: Enable SBE 38 secondary temperature sensor. x=N: Do not enable SBE 38.

FUNCTION	CATEGORY	COMMAND	DESCRIPTION
SBE 16plus-IM Acquisition Microcontroller Commands (ii = SBE 16plus-IM ID) <i>(continued)</i>	Output Format Setup	#iiOutputFormat=x	x=0: output raw frequencies and voltages in Hex. x=1: output converted data in Hex. x=2: output raw frequencies and voltages in decimal. x=3: output converted data in decimal.
		#iiOutputSal=x	x=Y: Calculate and output salinity (psu) if #iiOutputFormat=3 . x=N: Do not.
		#iiOutputSV=x	x=Y: Calculate and output sound velocity (m/sec) if #iiOutputFormat=3 . x=N: Do not.
		#iiOutputUCSD=x	x=Y: Calculate and output sigma-t (kg/m ³), battery voltage, and operating current (mA) with data polled while logging if #iiOutputFormat=3 . x=N: Do not.
		#iiOutputSN=x	x=Y: Output sample number with data from Dataii , #iiSL , #iiSLT , #iiTS , and #iiTSSOn if #iiOutputFormat=3 . x=N: Do not.
	Autonomous Sampling	#iiSampleInterval=x	x= interval (seconds) between samples (10 – 14,400).
		#iiStartNow	Start autonomous sampling now.
		#iiStartMMDDYY =mmddyy	Delayed start: month, day, year. Must follow with #iiStartHHMMSS=.
		#iiStartDDMMYY =ddmmyy	Delayed start: day, month, year. Must follow with #iiStartHHMMSS=.
		#iiStartHHMMSS =hhmmss	Delayed start: hour, minute, second.
		#iiStartLater	Start autonomous sampling at delayed start date and time.
	Data Upload	#iiStop	Stop autonomous sampling or waiting to start autonomous sampling. Press Enter key to get S> prompt before entering #iiStop . Must stop sampling before uploading data.
		#iiDDB,e	Upload data from sample b to e . Stop autonomous sampling before sending.
	Polled Sampling	#iiDHb,e	Upload headers from header b to e .
		#iiSL	Output last sample from buffer.
		#iiSLT	Output last sample from buffer, then take new sample and store in buffer.
		#iiTS	Take sample, store in buffer, output data.
	Testing Takes and outputs 100 samples for each test.	#iiTSSOn	Take sample, store in buffer and FLASH memory , output data.
		#iiTT	Measure temperature, output converted data.
		#iiTC	Measure conductivity, output converted data.
		#iiTP	Measure pressure, output converted data.
		#iiTV	Measure 4 external voltage channels, output converted data.
		#iiTF	Measure frequency (Quartz pressure sensor), output converted data.
		#iiT38	Measure SBE 38 (secondary temperature), output converted data.
		#iiTTR	Measure temperature, output raw data
		#iiTCR	Measure conductivity, output raw data.
		#iiTPR	Measure pressure, output raw data.
#iiTVR		Measure main battery voltage, lithium battery voltage, external current, pressure temperature, and 4 external voltage channels, output raw data.	
#iiTFR		Measure frequency (Quartz pressure sensor), output raw data.	
#iiPumpOn		Turn pump on for testing purposes.	
#iiPumpOff	Turn pump off for testing purposes.		

Note:
 Use Upload on the Toolbar or Upload Data in the Data menu to upload data that will be processed by SBE Data Processing. Manually entering the data upload command does not produce data with the required header information for processing by SBE Data Processing.

FUNCTION	CATEGORY	COMMAND	DESCRIPTION
SBE 16plus-IM Acquisition Microcontroller Commands (ii = SBE 16plus-IM ID) (continued)	Coefficients (F=floating point number; S=string with no spaces)	#iiDCal	Display calibration coefficients; all coefficients and dates listed below are included in display (as applicable). Use individual commands below to modify a particular coefficient or date.
		#iiTCALDATE=S	S=Temperature calibration date.
		#iiTAO=F	F=Temperature A0.
		#iiTA1=F	F=Temperature A1.
		#iiTA2=F	F=Temperature A2.
		#iiTA3=F	F=Temperature A3.
		#iiTOffset=F	F=Temperature offset correction.
		#iiCCalDate=S	S=Conductivity calibration date.
		#iiCG=F	F=Conductivity G.
		#iiCH=F	F=Conductivity H.
		#iiCI=F	F=Conductivity I.
		#iiCJ=F	F=Conductivity J.
		#iiCPCor=F	F=Conductivity pcor.
		#iiCTCor=F	F=Conductivity tcor.
		#iiCSlope=F	F=Conductivity slope correction.
		#iiCF0=F	F=Conductivity 0 value (not applicable to 16plus-IM).
		#iiPCalDate=S	S=Pressure calibration date.
		#iiPRange=F	F=Pressure sensor full scale range (psia).
		#iiPOffset=F	F=Pressure offset correction (db).
		#iiPA0=F	F=Strain gauge pressure A0.
		#iiPA1=F	F=Strain gauge pressure A1.
		#iiPA2=F	F=Strain gauge pressure A2.
		#iiPTempA0=F	F=Strain gauge pressure temperature A0.
		#iiPTempA1=F	F=Strain gauge pressure temperature A1.
		#iiPTempA2=F	F=Strain gauge pressure temperature A2.
		#iiPTCA0=F	F=Strain gauge pressure temperature compensation ptca0.
		#iiPTCA1=F	F=Strain gauge pressure temperature compensation ptca1.
		#iiPTCA2=F	F=Strain gauge pressure temperature compensation ptca2.
		#iiPTCB0=F	F=Strain gauge pressure temperature compensation ptcb0.
		#iiPTCB1=F	F=Strain gauge pressure temperature compensation ptcb1.
		#iiPTCB2=F	F=Strain gauge pressure temperature compensation ptcb2.
		#iiPC1=F	F=Quartz pressure C1.
		#iiPC2=F	F=Quartz pressure C2.
#iiPC3=F	F=Quartz pressure C3.		
#iiPD1=F	F=Quartz pressure D1.		
#iiPD2=F	F=Quartz pressure D2.		
#iiPT1=F	F=Quartz pressure T1.		
#iiPT2=F	F=Quartz pressure T2.		
#iiPT3=F	F=Quartz pressure T3.		
#iiPT4=F	F=Quartz pressure T4.		
#iiPSlope=F	F=Pressure slope correction.		
#iiExtFreqSF=F	F=External frequency (Quartz pressure sensor) scale factor.		

Appendix IV: SIM Hookup and Configuration

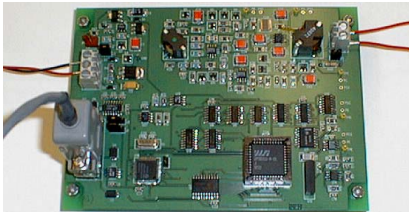
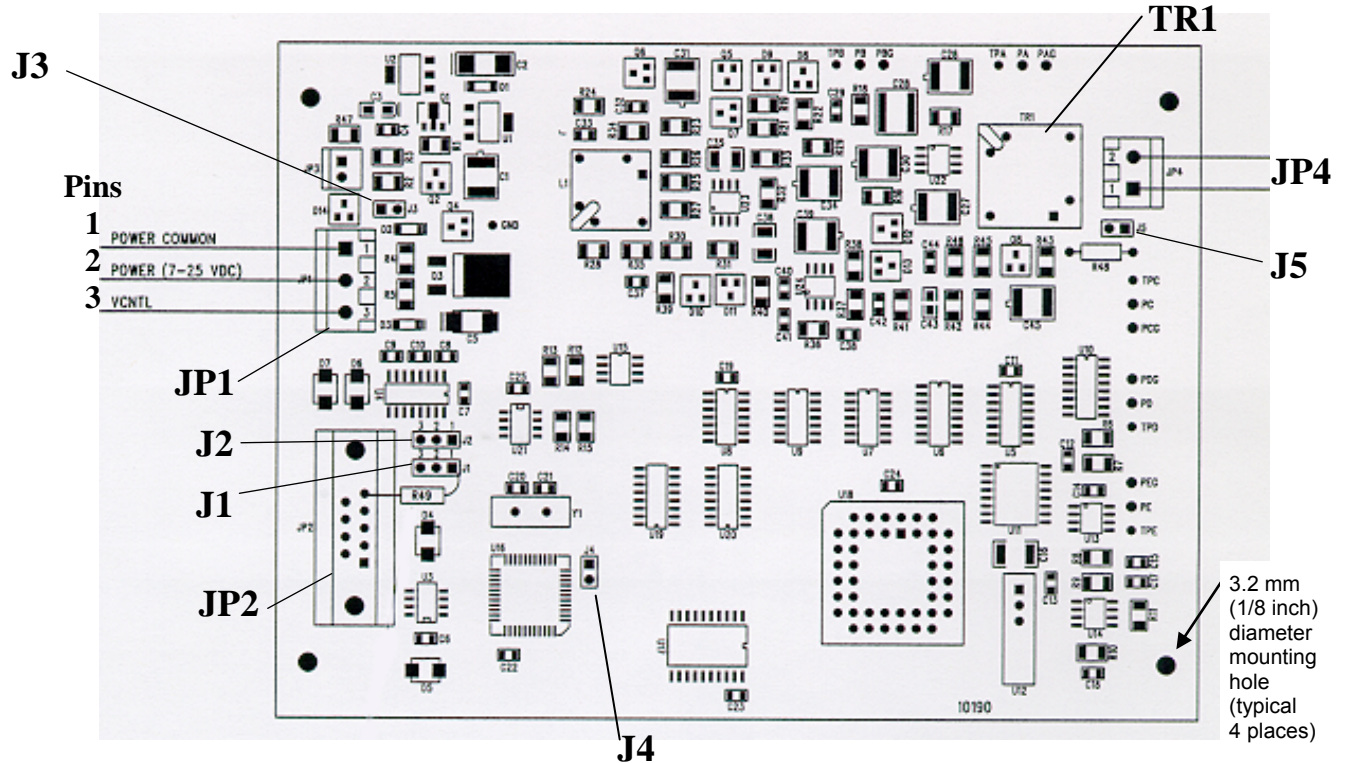

Photo shows SIM-Direct for use without Inductive Cable Coupler. SIM-Coupled for use with Inductive Cable Coupler is similar, but does not include TR1.

Dimensions:

PCB: 109 mm x 147.5 mm (4 1/4 x 5 3/4 inches)

Mounting holes: 90.5 mm x 138.1 mm (3 9/16 x 5 7/16 inches)

Power Connection

The SIM can be configured to power up in either of the following two modes:

- **Normal Power Switching (factory setting)** – The SIM runs when power is applied. Set up the SIM as follows:
 1. Connect Power Common to JP1 pin 1.
 2. Connect 7-25 VDC to JP1 pin 2.
 3. Verify there is no connection to JP1 pin 3.
 4. Verify jumper is across J3.
- **Logic Level Controlled Power Switching** – Power is always applied to JP1, pins 1 and 2. Voltage applied to JP1 pin 3 (VCNTL) switches power to the SIM. Set up the SIM as follows:
 1. Connect Power Common to JP1 pin 1.
 2. Connect 7-25 VDC to JP1 pin 2.
 3. Remove jumper on J3.

Note:

If VCNTL < 1 volt, SIM is Off (consuming < 100 microamps).
If VCNTL > 2 volts, SIM is On.

Interface Option Connection (J1, J2, and J4)

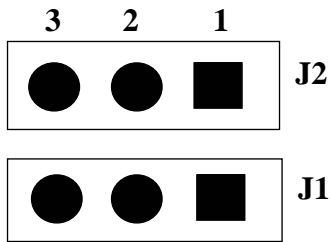

The SIM can be configured to accept RS-232 or RS-485:

- **RS-232 (factory setting)**
 1. Verify jumper is on J1 pins 2 and 3.
 2. Verify jumper is on J2 pins 2 and 3.
 3. Remove jumper on J4.
- **RS-485**
 1. Install jumper on J1 pins 1 and 2.
 2. Install jumper on J2 pins 1 and 2.
 3. Install jumper on J4.

I/O Connector Wiring (JP2)

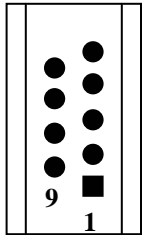

Connect wires to JP2 as follows:

- **RS-232**
 1. **Pin 2** - RS-232 transmit from SIM to computer
 2. **Pin 3** - RS-232 transmit from computer to SIM
 3. **Pin 5** - Power Common
- **RS-485**
 1. **Pin 4** - RS-485 'A'
 2. **Pin 5** - Power Common
 3. **Pin 6** - RS-485 'B'

Inductive Mooring Cable Connection (JP4)

Note:

ICC version 4 may have 3 wires in the cable. If you ordered the ICC with a pigtail termination, solder the white and white/black wires together and attach to 1 terminal of JP4. Attach the white/red wire to the other terminal.

- **SBE 16plus-IM installed with Inductive Cable Coupler (ICC)** - Connect wires from the ICC to JP4 on SIM-Coupled.
- **SBE 16plus-IM installed without Inductive Cable Coupler (ICC)** - Connect wires from the mooring cable and seawater ground to JP4 on SIM-Direct.

Normal Deployed Operation (J5)

- **Normal Deployed Operation** - Ensure jumper on J5 is installed.
- **Instrument Setup and Lab Testing** - Remove jumper on J5. Removing this jumper inserts a 1K resistor in series with the inductive loop, reducing the signal amplitude. This prevents the SBE 16plus-IMs in close proximity from responding to commands, which is especially important when sending the *ID= command.

Appendix V: AF24173 Anti-Foulant Device

AF24173 Anti-Foulant Devices supplied for user replacement are supplied in polyethylene bags displaying the following label:

AF24173 ANTI-FOULANT DEVICE	
FOR USE ONLY IN SEA-BIRD ELECTRONICS' CONDUCTIVITY SENSORS TO CONTROL THE GROWTH OF AQUATIC ORGANISMS WITHIN ELECTRONIC CONDUCTIVITY SENSORS.	
ACTIVE INGREDIENT:	
Bis(tributyltin) oxide.....	53.0%
OTHER INGREDIENTS:	<u>47.0%</u>
Total.....	100.0%
DANGER	
See the complete label within the Conductivity Instrument Manual for Additional Precautionary Statements and Information on the Handling, Storage, and Disposal of this Product.	
Net Contents: Two anti-foulant devices	
Sea-Bird Electronics, Inc.	EPA Registration No. 74489-1
1808 - 136 th Place Northeast	EPA Establishment No. 74489-WA-1
Bellevue, WA 98005	

AF24173 Anti-Foulant Device

FOR USE ONLY IN SEA-BIRD ELECTRONICS' CONDUCTIVITY SENSORS TO CONTROL THE GROWTH OF AQUATIC ORGANISMS WITHIN ELECTRONIC CONDUCTIVITY SENSORS.

ACTIVE INGREDIENT:

Bis(tributyltin) oxide..... 53.0%
 OTHER INGREDIENTS: 47.0%
 Total..... 100.0%

DANGER

See Precautionary Statements for additional information.

FIRST AID	
If on skin or clothing	<ul style="list-style-type: none"> • Take off contaminated clothing. • Rinse skin immediately with plenty of water for 15-20 minutes. • Call a poison control center or doctor for treatment advice.
If swallowed	<ul style="list-style-type: none"> • Call poison control center or doctor immediately for treatment advice. • Have person drink several glasses of water. • Do not induce vomiting. • Do not give anything by mouth to an unconscious person.
If in eyes	<ul style="list-style-type: none"> • Hold eye open and rinse slowly and gently with water for 15-20 minutes. • Remove contact lenses, if present, after the first 5 minutes, then continue rinsing eye. • Call a poison control center or doctor for treatment advice.
HOT LINE NUMBER	
Note to Physician	Probable mucosal damage may contraindicate the use of gastric lavage.
Have the product container or label with you when calling a poison control center or doctor, or going for treatment. For further information call National Pesticide Telecommunications Network (NPTN) at 1-800-858-7378.	

Net Contents: Two anti-foulant devices

Sea-Bird Electronics, Inc.
 1808 - 136th Place Northeast
 Bellevue, WA 98005

EPA Registration No. 74489-1
 EPA Establishment No. 74489-WA-1

PRECAUTIONARY STATEMENTS**HAZARD TO HUMANS AND DOMESTIC ANIMALS****DANGER**

Corrosive - Causes irreversible eye damage and skin burns. Harmful if swallowed. Harmful if absorbed through the skin or inhaled. Prolonged or frequently repeated contact may cause allergic reactions in some individuals. Wash thoroughly with soap and water after handling.

PERSONAL PROTECTIVE EQUIPMENT**USER SAFETY RECOMMENDATIONS**

Users should:

- Remove clothing immediately if pesticide gets inside. Then wash thoroughly and put on clean clothing.
- Wear protective gloves (rubber or latex), goggles or other eye protection, and clothing to minimize contact.
- Follow manufacturer's instructions for cleaning and maintaining PPE. If no such instructions for washables, use detergent and hot water. Keep and wash PPE separately from other laundry.
 - Wash hands with soap and water before eating, drinking, chewing gum, using tobacco or using the toilet.

ENVIRONMENTAL HAZARDS

Do not discharge effluent containing this product into lakes, streams, ponds, estuaries, oceans, or other waters unless in accordance with the requirements of a National Pollutant Discharge Elimination System (NPDES) permit and the permitting authority has been notified in writing prior to discharge. Do not discharge effluent containing this product to sewer systems without previously notifying the local sewage treatment plant authority. For guidance contact your State Water Board or Regional Office of EPA. This material is toxic to fish. Do not contaminate water when cleaning equipment or disposing of equipment washwaters.

PHYSICAL OR CHEMICAL HAZARDS

Do not use or store near heat or open flame. Avoid contact with acids and oxidizers.

DIRECTIONS FOR USE

It is a violation of Federal Law to use this product in a manner inconsistent with its labeling. For use only in Sea-Bird Electronics' conductivity sensors. Read installation instructions in the applicable Conductivity Instrument Manual.

STORAGE AND DISPOSAL

PESTICIDE STORAGE: Store in original container in a cool, dry place. Prevent exposure to heat or flame. Do not store near acids or oxidizers. Keep container tightly closed.

PESTICIDE SPILL PROCEDURE: In case of a spill, absorb spills with absorbent material. Put saturated absorbent material to a labeled container for treatment or disposal.

PESTICIDE DISPOSAL: Pesticide that cannot be used according to label instructions must be disposed of according to Federal or approved State procedures under Subtitle C of the Resource Conservation and Recovery Act.

CONTAINER DISPOSAL: Dispose of in a sanitary landfill or by other approved State and Local procedures.

Appendix VI: Replacement Parts

Part Number	Part	Application Description	Quantity in 16plus-IM
22018	Batteries, alkaline D-cell, Duracell MN 1300 (LR20)	Power 16plus-IM	9
801294	Battery cover plate	Retains batteries	1
801483	9D (10.8V / 42 amp-hour) lithium battery pack kit	For longer deployments; batteries not included in kit, and not available from Sea-Bird	-
801479	3DD (10.8V / 30 amp-hour) lithium battery pack kit	For longer deployments; batteries not included in kit, and not available from Sea-Bird	-
30411	Triton X-100	Octyl Phenol Ethoxylate – Reagent grade non-ionic cleaning solution for conductivity cell (supplied in 100% strength; dilute as directed)	1
801542	AF24173 Anti-Foulant Device	bis(tributyltin) oxide device inserted into anti-foulant device cup, for moored applications	1 (set of 2)
231505	Anti-foulant device cap	Secures AF24173 Anti-Foulant Device in cup	2
30984	Anti-foulant device plug	Seals end of anti-foulant assembly when not deployed	2
30900	Machine screw, 1/4-20 x 2" hex head, titanium	Secures mounting clamp	4
30633	Washer, 1/4" split ring lock, titanium	For screw 30900 (secures mounting clamp)	4
30634	Washer 1/4" flat, titanium	For screw 30900 (secures mounting clamp)	4
31019	O-ring 2-088 N674-70	For screw 30900 (retains mounting clamp hardware)	4
171887	9-pin DB-9P to 9-pin DB-9S I/O cable, 3 m (10 ft) long	From SIM to computer	1
171888	25-pin DB-25S to 9-pin DB-9P cable adapter	For use with computer with DB-25 connector	1
17133*	2-pin RMG-4FS to 2-pin RMG-4FS cable, 1.1 m (3.7 ft) long	From 16plus-IM to optional pump	1
17044.1*	2-pin RMG-2FS dummy plug and locking sleeve	For when pump not used	1
17045.1*	3-pin RMG-3FS dummy plug and locking sleeve	For when optional PAR connector not used	-
17046.1 *	4-pin RMG-4FS dummy plug and locking sleeve	For when optional RS-232 connector not used	-
17047.1*	6-pin AG-206 dummy plug and locking sleeve	For when auxiliary differential input sensors not used	2
171503	2-pin MCIL-2FS to 2-pin MCIL-2FS (wet-pluggable connector) cable, 1.1 m (3.7 ft) long	From 16plus-IM to optional pump	1
171497.1	2-pin MCDC-2-F wet-pluggable dummy plug and locking sleeve	For when pump not used	1
171500.1	3-pin MCDC-3-F wet-pluggable dummy plug and locking sleeve	For when optional PAR connector not used	-
171398.1	4-pin MCDC-4-F wet-pluggable dummy plug and locking sleeve	For when optional RS-232 connector not used	-
171498.1	6-pin MCDC-6-F wet-pluggable dummy plug and locking sleeve	For when auxiliary differential input sensors not used	2
30388	Tygon tube, 1/2 inch ID x 3/4 inch OD	Main plumbing tubing for pumped configuration	-
30579	Tygon tube, 3/8 inch ID x 1/2 inch OD	13 mm (0.5 inch) long pieces used for pumped configurations on conductivity cell exhaust cap and for SBE 43 intake and exhaust to fit to main plumbing	-

* For standard bulkhead connectors

continued on next page

continued from previous page

Part Number	Part	Application Description	Quantity in 16plus-IM
22009	Panasonic BR-2/3A lithium batteries	Back-up lithium cells on Power PCB	3
60021	Spare battery end cap hardware and o-rings	O-rings and hardware, including: <ul style="list-style-type: none"> • 30145 Screw, 6-32 x 1/2 Phillips-head, stainless steel (secures battery cover plate to battery posts) • 30242 Washer, #6 flat, stainless steel (for 30145) • 30816 Parker 2-234E603-70 (battery end cap to housing piston seals, sensor end cap to housing seals) 	-
50274	Spare o-ring kit	Assorted o-rings, including: <ul style="list-style-type: none"> • 30816 Parker 2-234E603-70 (battery end cap to housing piston seals, sensor end cap to housing seals) • 30507 Parker 2-206N674-70 (each end of conductivity cell) • 30802 Parker 2-110DUR070, ethylene (titanium conductivity cell tray face seal, groove surface) • 30809 Morrison seal, .047" hole, NIT (temperature probe Morrison seal) • 30072 Parker 2-017N674-70 (bulkhead connector seal) • 30070 Parker 3-904N674-70 (pressure sensor mounting seal) • 30087 Parker 2-232N674-70 (buffer for top retainer of PCB sandwich assembly) • 30801 Parker 5-374E603-70 (base of battery bulkhead seal) 	-
50273	Spare hardware kit	Assorted hardware, including: <ul style="list-style-type: none"> • 30145 Screw, 6-32 x 1/2 Phillips-head, stainless steel (secures battery cover plate to battery posts) • 30242 Washer, #6 flat, stainless steel (for 30145) • 30414 Washer, #12, internal tooth (secures battery bulkhead retainer) • 30954 Screw 4-40 x 3/16 Phillips-head, stainless steel (securing screw for PCB retainer rod) • 31119 Screw 6-32 x 5/8 Truss Head (secures battery bulkhead retainer to bulkhead bottom plate) • 30176 Screw, 10-24 x 3/4, Phillips-head, stainless steel (secures Celcon threaded ring inside titanium battery end cap) • 30249 Washer #10, Flat, stainless steel (for 30176) • 30447 Bolt, 1/4-20 x 1 1/4 Hex, titanium (secures lift eye to battery end cap) • 31089 Screw, 10-32 x 1/2 flat Phillips-head, titanium (secures sensor end cap to housing - side opposite conductivity cell guard) • 31090 Screw, 10-32 x 5/8 flat Phillips-head, titanium (secures conductivity cell guard to housing) • 31118 Screw, 10-32 x 3/8 Phillips-head, titanium (secures conductivity cell guard to sensor end cap) • 30875 Bolt 1/4-20 x 5/8 Hex, titanium (secures connector guard to sensor end cap) • 30633 Washer, 1/4" split ring lock, titanium (for 30875) • 30919 Screw, 6-32 x 3/8 flat slotted, titanium (secures anti-foulant device cup to conductivity cell guard) • 31066 Screw, 8-32 x 3/4 socket, titanium (secures conductivity cell and TC duct to sensor end cap) 	-
50323	Seaspares kit, standard connectors	Includes o-rings, hardware, bulkhead connectors, dummy plugs, etc.: <ul style="list-style-type: none"> • 50087 Conductivity cell filling and storage kit • 50273 Spare hardware kit (see above) • 50274 Spare o-ring kit (see above) • 801294 Battery cover plate • 17044.1 2-pin RMG-2FS dummy plug with locking sleeve • 17047.1 6-pin AG-206 dummy plug with locking sleeve • 17652 2-pin XSG-2-BCL-HP-SS bulkhead connector • 17628 6-pin AG-306-HP-SS bulkhead connector • 30388 Vinyl tube, 3/4" x 1/2" (main sensor plumbing tubing) • 30409 Teflon tape (for insides of hose clamps) • 30411 Triton X100 (for cell cleaning) • 30457 Parker O-Lube (o-ring lubricant) 	-

continued on next page

continued from previous page

Part Number	Part	Application Description	Quantity in 16plus-IM
50324	Seaspares kit, wet-pluggable connectors	Includes o-rings, hardware, bulkhead connectors, dummy plugs, etc.: <ul style="list-style-type: none"> • 50087 Conductivity cell filling and storage kit • 50273 Spare hardware kit (see above) • 50274 Spare o-ring kit (see above) • 801294 Battery cover plate • 171192 Locking sleeve • 171497 2-pin MCDC-2-F wet-pluggable dummy plug • 171498 6-pin MCDC-6-F wet-pluggable dummy plug • 172019 2-pin MCBH-2MP(WB) ½-20 bulkhead connector • 172022 6-pin MCBH-6MP(WB) ½-20 bulkhead connector • 30388 Vinyl tube, ¾" x ½" (main sensor plumbing tubing) • 30409 Teflon tape (for insides of hose clamps) • 30411 Triton X100 (for cell cleaning) • 30457 Parker O-Lube (o-ring lubricant) 	-

Index

.con file · 37, 38, 39, 45, 60, 67

A

About Sea-Bird · 5
 Anti-Foulant Devices · 81
 replacing · 66
 Autonomous sampling · 27
 Auxiliary sensors · 14

B

Batteries · 9, 12, 52
 replacing · 63
 Battery endurance · 13

C

Calibration · 9, 67
 Calibration coefficients · 44
 Circuitry · 72
 Cleaning · 64, 65
 Clock · 9
 Combo sampling · 28
 Command summary · 75
 Commands
 autonomous sampling · 41
 calibration coefficients · 44
 data upload · 42
 descriptions · 31
 echo · 32
 get data · 33
 global · 33
 logging · 41
 output format · 40
 polled sampling · 42
 power on/off · 32
 pressure sensor · 37
 RS-232 sensor · 39
 SBE 16*plus*-IM acquisition microcontroller · 34
 SBE 16*plus*-IM communication microcontroller · 33
 SBE 16*plus*-IM ID · 33
 SBE 38 · 39
 setup · 35
 SIM firmware version · 32
 status · 34
 Surface Inductive Modem · 32
 testing · 43
 timeout · 32
 voltage sensor · 38
 Communication defaults · 22
 Configuration file · 37, 38, 39, 45, 60, 67
 Configuration options · 14
 Connectors · 11, 62
 Corrosion precautions · 62

D

Data output format · 46
 Data processing · 60
 Data storage · 9, 12
 Deployment
 installation · 53
 preparing for · 18
 setup · 52
 Description · 7
 Dimensions · 11

E

Editing data files · 61
 Electronics disassembly/reassembly · 74
 End cap · 11, 62

F

Format
 data output · 46
 Functional description · 72

G

Glossary · 71

I

ICC · *See* Inductive Cable Coupler
 ID
 setting · 19
 Inductive Cable Coupler · 17, 55

L

Limited liability statement · 2
 Logging · 27

M

Maintenance · 62
 Memory · 9
 Modes · *See* Sampling modes
 Mooring cable · 17

O

Operation description · 25

P

Parts
 replacement · 85
Plumbing · 14, 15
Polled sampling · 26
Power · 9, 12
Power endurance · 13
Pressure sensor
 maintenance · 65
Processing data · 60
Pump · 14
 maintenance · 65
Pump operation · 29

Q

Quick start · 5

R

Recovery
 physical handling · 56
 uploading data · 57
Replacement parts · 85

S

Sampling modes · 26
 autonomous · 27
 combo · 28
 logging · 27
 polled · 26
SBE 38 · 39
SBE Data Processing · 8, 18, 59, 60
SEASOFT · 8, 18
SEATERM · 8, 18, 20, 57
 main screen · 20
 toolbar buttons · 21
Sensors · 9
SIM · *See* Surface Inductive Modem
Software · 8
Software installation · 18
Specifications · 9
Storage · 64
Surface Inductive Modem
 description · 16
 wiring · 79
System description · 7

T

Test
 setup · 19
Testing · 19
Timeout descriptions · 25
Triton · 71
Troubleshooting · 69

U

Unpacking SBE 16*plus*-IM · 6
Uploading data · 57

W

Wiring · 55