

SBE 37-IM MicroCAT

*Conductivity, Temperature, and (optional) Pressure Recorder
with Inductive Modem*



*Shown with titanium housing;
ShallowCAT plastic housing available*

User's Manual

Sea-Bird Electronics, Inc.
13431 NE 20th Street
Bellevue, Washington 98005 USA
Telephone: +1 425-643-9866
Fax: +1 425-643-9954
E-mail: seabird@seabird.com
Website: www.seabird.com

Manual version #031, 03/11/14
37-IM Digital Firmware 3.1 & later
37-IM Modem Firmware 2.0a & later
SIM Firmware 3.0a & later
IMM firmware 1.09 & later
SeatermV2 version 2.3.0 and later
SBE Data Processing version 7.23.1 and later



Limited Liability Statement

Extreme care should be exercised when using or servicing this equipment. It should be used or serviced only by personnel with knowledge of and training in the use and maintenance of oceanographic electronic equipment.

SEA-BIRD ELECTRONICS, INC. disclaims all product liability risks arising from the use or servicing of this system. SEA-BIRD ELECTRONICS, INC. has no way of controlling the use of this equipment or of choosing the personnel to operate it, and therefore cannot take steps to comply with laws pertaining to product liability, including laws which impose a duty to warn the user of any dangers involved in operating this equipment. Therefore, acceptance of this system by the customer shall be conclusively deemed to include a covenant by the customer to defend, indemnify, and hold SEA-BIRD ELECTRONICS, INC. harmless from all product liability claims arising from the use or servicing of this system.

Declaration of Conformity

Sea-Bird Electronics, Inc.
13431 NE 20th Street, Bellevue, WA 98005 USA

DECLARATION OF CONFORMITY

Manufacturer's Name: Sea-Bird Electronics
Manufacturer's Address: 13431 NE 20th Street
Bellevue, WA 98005, USA

The Authorized Representative located within the Community is:
OTT MESSTECHNIK GmbH & Co.KG
P.O.Box: 2140 / 87411 Kempten / Germany
Ludwigstrasse 16 / 87437 Kempten
Internet: <http://www.ott.com>
Phone: +49 831 5617 – 100
Fax: +49 831 5617 - 209

Device Description: Various Data Acquisition Devices and Sensors

Model Numbers:

3S	3F	3plus	4C	4M	5T	5P	5M	7
8	9plus	11plus	14	16plus V2	16plus-IM V2		17plus V2	18
19plus V2	21	25plus	26plus	27	29	32	32C	32SC
33	35	35RT	36	37-IMP	37-IM	37-SMP	37-SM	37-SIP
37-SI	38	39	39-IM	39plus	41	41CP	43	43F
44	45	49	50	52-MP	53BPR		55	56
63	SIM	ICC	IMM	PDIM	AFM	90488	90204	90402
90504	Glider Payload CTD		NiMH Battery Charger and Battery Pack					

Applicable EU Directives: Machinery Directive 98 / 37 /EC
EMC Directive 2004 / 108 /EC
Low Voltage Directive (73 / 23 /EEC) as amended by (93 / 68 /EEC)

Applicable Harmonized Standards:
EN 61326-1:2006 Class A Electrical Equipment for Measurement, Control, and Laboratory Use, EMC Requirement – Part 1: General Requirements
(EN 55011:2007 Group 1, Class A)

EN 61010-1:2001, Safety Requirements for Electrical Equipments for Measurement, Control, and Laboratory Use – Part 1: General Requirements

Declaration based upon compliance to the Essential Requirements and Letter of Opinion from CKC Certification Services, LLC., Notified Body 0976

I, the undersigned, hereby declare that the equipment specified above conforms to the above European Union Directives and Standards.

Authorized Signature: 
Name: Nordeen Larson
Title of Signatory: President
Date: 3 September 2013
Place: Bellevue, WA

Table of Contents

Limited Liability Statement	2
Declaration of Conformity	3
Table of Contents	4
Section 1: Introduction	6
About this Manual	6
Quick Start	6
Unpacking MicroCAT	7
Shipping Precautions	8
Section 2: Description of MicroCAT	9
System Description	9
Specifications	11
Dimensions	12
Cables	13
Sample Timing	14
Battery Pack Endurance	14
Surface Inductive Modem (SIM) or Inductive Modem Module (IMM)	16
Mooring Cable and Wiring Requirements	17
Section 3: Preparing MicroCAT for Deployment	18
Battery Pack Installation	18
Software Installation	20
SeatermV2 Use	21
Power and Communications Test and Setting MicroCAT IDs – Using Surface Inductive Modem (SIM)	25
Test Setup with SIM	25
Test and Set MicroCAT ID Using MicroCAT with SIM	26
Power and Communications Test and Setting MicroCAT IDs – Using Inductive Modem Module (IMM)	28
Test Setup with IMM	28
Setup of IMM for use with MicroCAT	29
Test and Set MicroCAT ID Using MicroCAT with IMM	30
Section 4: Deploying and Operating MicroCAT	32
Operation Description	32
Timeout Descriptions	33
Sampling Modes	33
Polled Sampling	34
Autonomous Sampling (Logging commands)	35
Combo Sampling	36
Averaging Sampling	37
Command Descriptions	38
SIM Commands	39
MicroCAT Communication Microcontroller Commands	41
MicroCAT Acquisition Microcontroller Commands	43
Data Format	57
Setup for Deployment	62
Attaching MicroCAT to Mooring Cable	63
System Installation and Wiring	64
Installing Optional Inductive Cable Coupler (ICC)	64

Recovery	65
Uploading and Processing Data	66
Upload Using RS-232 (Serial Mode) Telemetry	67
Upload Using Inductive Modem Telemetry (recommended only for uploading small amounts of data).....	70
Processing Data	73
Editing Raw Data File.....	77
Section 5: Routine Maintenance and Calibration	78
Corrosion Precautions.....	78
Conductivity Cell Maintenance	78
Handling Instructions for Plastic <i>ShallowCAT</i>	79
Replacing AA Cells	80
O-Ring Maintenance.....	80
Pressure Sensor (optional) Maintenance	80
Replacing Anti-Foulant Devices (SBE 37-SI, SM, IM).....	81
Sensor Calibration.....	82
Section 6: Troubleshooting.....	84
Problem 1: Unable to Communicate with MicroCAT	84
Problem 2: No Data Recorded	84
Problem 3: Unreasonable T, C, or P Data.....	85
Problem 4: Salinity Spikes.....	85
Glossary	86
Appendix I: Functional Description	88
Sensors.....	88
Sensor Interface	88
Real-Time Clock.....	88
Appendix II: Electronics Disassembly/Reassembly	89
Appendix III: Command Summary	90
Appendix IV: SIM Hookup and Configuration	94
Power Connection.....	94
Interface Option Connection (J1, J2, and J4) and I/O Connector Wiring (JP2).....	95
Notes on RS-485 Interface.....	95
Inductive Mooring Cable Connection (JP4)	95
Normal Deployed Operation (J5).....	95
Appendix V: <i>Old-Style</i> Compatible Commands	96
MicroCAT Communication Microcontroller Commands	96
MicroCAT Acquisition Microcontroller Commands	96
Appendix VI: AF24173 Anti-Foulant Device.....	98
Appendix VII: Replacement Parts	102
Appendix VIII: Manual Revision History	104
Index.....	107

Section 1: Introduction

This section includes a Quick Start procedure, photos of a typical MicroCAT shipment, and battery shipping precautions.

About this Manual

This manual is to be used with the SBE 37-IM MicroCAT Conductivity and Temperature Recorder (pressure optional) with Inductive Modem. It is organized to guide the user from installation through operation and data collection. We've included detailed specifications, command descriptions, maintenance and calibration information, and helpful notes throughout the manual.

Sea-Bird welcomes suggestions for new features and enhancements of our products and/or documentation. Please contact us with any comments or suggestions (seabird@seabird.com or 425-643-9866). Our business hours are Monday through Friday, 0800 to 1700 Pacific Standard Time (1600 to 0100 Universal Time) in winter and 0800 to 1700 Pacific Daylight Time (1500 to 0000 Universal Time) the rest of the year.

Quick Start

Follow these steps to get a Quick Start using the MicroCAT. The manual provides step-by-step details for performing each task:

1. Perform pre-check (*Section 3: Preparing MicroCAT for Deployment*):
 - A. Install lithium AA cells.
 - B. Test power and communications, and set MicroCAT ID.
2. Deploy MicroCAT (*Section 4: Deploying and Operating MicroCAT*):
 - A. Install new lithium AA cells if necessary.
 - B. Ensure all data has been uploaded, and then set **#iiSampleNumber=0** to make entire memory available for recording if desired.
 - C. Set date and time.
 - D. Establish setup and logging parameters.
 - E. Check status (**#iiDS**) and calibration coefficients (**#iiDC**) to verify setup.
 - F. Set MicroCAT to start logging now or in the future.
 - G. Remove protective plugs from anti-foulant device cups, and verify AF24173 Anti-Foulant Devices are installed. Leave protective plugs off for deployment.
 - H. Install MicroCAT on mooring cable.
 - I. (optional) Install Inductive Cable Coupler on mooring cable.
 - J. Wire system.

Unpacking MicroCAT

Shown below is a typical MicroCAT shipment.



SBE 37-IM MicroCAT (with titanium housing)



2 AA lithium cells



Cell cleaning solution (Triton-X)



Spare parts (hardware and o-rings) kit



Software, and Electronics Copies of Software Manuals and User Manual

Note:
MicroCAT can be used with SIM or with IMM; IMM not shown.

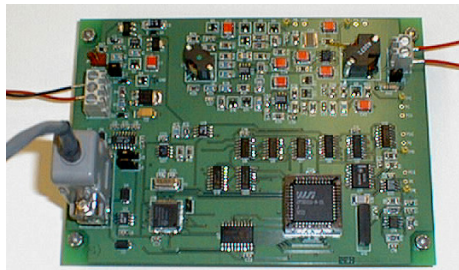

Surface Inductive Modem (SIM) PCB (one per mooring, optional)

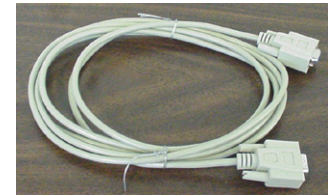

I/O Cable (included with SIM)

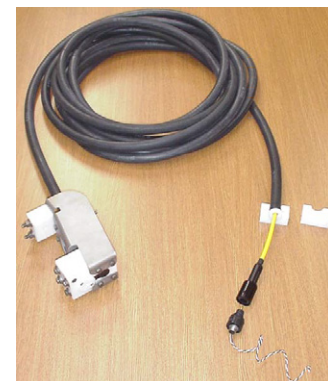

Inductive Cable Coupler (ICC) (optional with SIM, one per mooring)

Shipping Precautions

DISCLAIMER / WARNING:

The shipping information provided in is a general overview of lithium shipping requirements; it does not provide complete shipping information. The information is provided as a courtesy, to be used as a guideline to assist properly trained shippers. These materials do not alter, satisfy, or influence any federal or state requirements. These materials are subject to change due to changes in government regulations. Sea-Bird accepts no liability for loss or damage resulting from changes, errors, omissions, or misinterpretations of these materials. **See the current edition of the IATA Dangerous Good Regulations for complete information on packaging, labeling, and shipping document requirements.**



WARNING!
Do not ship assembled battery pack.

Assembled battery pack

For its main power supply, the MicroCAT uses twelve 3.6-volt AA lithium cells (Saft LS14500). The MicroCAT was shipped from the factory with the cells packaged separately within the shipping box (not inside MicroCAT).

BATTERY PACKAGING

Cells are packed in heat-sealed plastic, and then placed in bubble-wrap outer sleeve and strong packaging for shipment.



If the shipment is not packaged as described above, or does not meet the requirements below, the shipment is considered Dangerous/Hazardous Goods, and must be shipped according to those rules.

	1-5 MicroCATs and associated cells, but no spares	1-5 MicroCATs and associated cells, plus up to 2 spare cell sets/MicroCAT	Spares (without MicroCATs) – Note new rules as of January 1, 2013
UN #	UN3091	UN3091	Must be shipped as Class 9 Dangerous Goods . If re-shipping spares, you must have your own Dangerous Goods program.
Packing Instruction (PI) #	969	969	
Passenger Aircraft	Yes	No	
Cargo Aircraft	Yes	Yes	
Labeling Requirement	1 **	1, 2 **	
Airway Bill (AWB) Requirement	Yes *	Yes *	

* AWB must contain following information in Nature and Quantity of Goods Box: "Lithium Metal Batteries", "Not Restricted", "PI #"

** Labels are defined below:



2

1 – Shipper must provide an emergency phone number

Note:

Remove the cells before returning the MicroCAT to Sea-Bird. Do not return used cells when shipping the MicroCAT for calibration or repair. All setup information is preserved when the cells are removed.

Install the battery pack assembly in the MicroCAT for testing (see *Battery Installation* in Section 3). **If you will re-ship the MicroCAT after testing:**

1. Remove the battery pack assembly from the MicroCAT.
2. Remove the cells from the battery pack assembly.
3. Pack the cells properly for shipment, apply appropriate labels, and prepare appropriate shipping documentation.

Section 2: Description of MicroCAT

This section describes the functions and features of the SBE 37-IM MicroCAT, including specifications, dimensions, sample timing, battery pack endurance, and mooring requirements.

System Description



Titanium housing

Plastic ShallowCAT housing

The SBE 37-IM MicroCAT is a high-accuracy conductivity and temperature recorder (pressure optional) with internal battery pack and non-volatile memory. It uses an Inductive Modem (IM) to transmit data and receive commands over a plastic-jacketed steel mooring cable (or other insulated conductor), using differential-phase-shift-keyed (DPSK) telemetry. No electrical cables or connectors are required. The MicroCAT's built-in inductive coupler (split toroid) and cable clamp provide easy and secure attachment to the mooring cable. Designed for moorings and other long-duration, fixed-site deployments, MicroCATs have non-corroding housings. The MicroCAT is rated for operation to 350 meters (plastic *ShallowCAT* housing) or 7000 meters (titanium housing), or pressure sensor full-scale range.

Communicating with one or more MicroCATs requires the use of a Sea-Bird Surface Inductive Modem (SIM) or Inductive Modem Module (IMM). These devices provide a standard serial interface between the user's computer or other controlling device and up to 100 MicroCATs (or other IM-compatible sensors), coupled to a single cable. The user can communicate with these devices via full-duplex RS-232C (optional half-duplex RS-485 for SIM). Commands and data are transmitted half-duplex between these devices and the MicroCAT.

Notes:

- For detailed information on inductive modem systems, see *Real-Time Oceanography with Inductive Moorings*, at www.seabird.com under Technical Papers.
- Half-duplex communication is **one-direction** at a time (i.e., you cannot send commands and receive data at the same time). For example, if the SIM or IMM command a MicroCAT to upload data, nothing else can be done while the data is being sent – the data upload cannot be stopped, and commands cannot be sent to other MicroCATs on the line.

Commands can be sent to the MicroCAT to provide status display, data acquisition setup, data retrieval, and diagnostic tests. User-selectable operating modes include:

- **Polled sampling** – On command, the MicroCAT wakes up, takes one sample, transmits data, and goes to sleep.
- **Autonomous sampling** – At pre-programmed intervals, the MicroCAT wakes up, samples, stores data in its FLASH memory, and goes to sleep.
- **Combo sampling** – Autonomous sampling is in progress, and the MicroCAT can be commanded to transmit the last stored data.
- **Averaging sampling** – Autonomous sampling is in progress, and the MicroCAT can be commanded to transmit the average of the individual data samples acquired since its last request.

Calibration coefficients stored in EEPROM allow the MicroCAT to transmit data in engineering units. The MicroCAT retains the temperature and conductivity sensors used in the SeaCAT and SeaCAT*plus* family. The MicroCAT's aged and pressure-protected thermistor has a long history of exceptional accuracy and stability (typical drift is less than 0.002 °C per year).

The MicroCAT's internal-field conductivity cell is immune to proximity errors and unaffected by external fouling. A plastic cup with threaded cover at each end of the cell retains the expendable AF24173 Anti-Foulant Device.

The MicroCAT's optional strain-gauge pressure sensor is available in the following pressure ranges: 20, 100, 350, 600, 1000, 2000, 3500, and 7000 meters. Compensation of the temperature influence on pressure offset and scale is performed by the MicroCAT's CPU.

ASCII data upload can be accomplished without opening the MicroCAT housing, using the inductive modem telemetry (baud rate between MicroCAT and SIM or IMM is always 1200 baud). Alternatively, by removing the battery end cap to access the internal RS-232 connector, fast binary upload of large data sets can be performed at rates up to 115,200 baud, using the optional data I/O cable (PN 801836).

Additionally, future upgrades and enhancements to the MicroCAT firmware can be easily installed in the field through the internal RS-232 connector and optional data I/O cable, without the need to return the MicroCAT to Sea-Bird.

Notes:

- Help files provide detailed information on the software.
- A separate software manual on CD-ROM contains detailed information on SBE Data Processing.
- Sea-Bird supplies the current version of our software when you purchase an instrument. As software revisions occur, we post the revised software on our FTP site. See our website (www.seabird.com) for the latest software version number, a description of the software changes, and instructions for downloading the software from the FTP site.

The MicroCAT is supplied with a powerful software package, Seasoft[®] V2, which includes:

- **Deployment Endurance Calculator** – program for determining deployment length based on user-input deployment scheme, instrument power requirements, and battery pack capacity.
- **SeatermV2** – terminal program for easy communication and data retrieval. SeatermV2 is a *launcher*. SeatermV2 is a *launcher*, and launches the appropriate terminal program for the selected instrument (**SeatermIM** for Inductive Modem instruments such as this MicroCAT).
- **SBE Data Processing** - program for calculation and plotting of conductivity, temperature, pressure (optional), and derived variables such as salinity, sound velocity, depth, density, etc.

Specifications

Note:
Pressure ranges are expressed in meters of deployment depth capability.

	Temperature (°C)	Conductivity (S/m)	Optional Pressure
Measurement Range	-5 to +45	0 to 7 (0 to 70 mS/cm)	0 to full scale range: 20 / 100 / 350 / 600 / 1000 / 2000 / 3500 / 7000 meters
Initial Accuracy	± 0.002 (-5 to 35 °C); ± 0.01 (35 to 45 °C)	± 0.0003 (0.003 mS/cm)	± 0.1% of full scale range
Typical Stability	0.0002 per month	0.0003 (0.003 mS/cm) per month	0.05% of full scale range per year
Resolution	0.0001	0.00001 (0.0001 mS/cm)	0.002% of full scale range
Sensor Calibration	+1 to +32	0 to 6; physical calibration over range 2.6 to 6 S/m, plus zero conductivity (air)	Ambient pressure to full scale range in 5 steps
Memory	8 Mbyte non-volatile FLASH memory		
Data Storage	Conductivity & temperature: 6 bytes/sample (3 bytes each). Time: 4 bytes/sample. Pressure (optional): 5 bytes/sample.		
	Recorded Parameters	Memory Space - (number of samples)	
	C, T, and time	800,000	
	C, T, P, and time	533,000	
Real-Time Clock	32,768 Hz TCXO accurate to ±1 minute/year.		
Internal Battery Pack	Nominal 10.6 Amp-hour pack consisting of 12 AA Saft LS 14500 lithium cells (3.6 V and 2.45 Amp-hours each). Capacity for more than 300,000 samples for a typical sampling scheme (see <i>Battery Pack Endurance</i> for example calculation). See <i>Shipping Precautions</i> in <i>Section 1: Introduction</i> . Note: Saft cells can be purchased from Sea-Bird or other sources. See Saft's website for suppliers (www.saftbatteries.com). Alternatively, substitute either of the following: - Tadiran TL-4903, AA (3.6 V and 2.4 Amp-hours each) (www.tadiran.com) - Electrochem 3B0064/BCX85, AA (3.9 V and 2.0 Amp-hours each) (www.electrochemsolutions.com)		
Power Requirements	<ul style="list-style-type: none"> • Quiescent Current: 120 microAmps • IM Communications Current: 2.5 milliAmps • IM Communications Time: 0.5 seconds per sample • Acquisition Current: 13 milliAmps Acquisition time: 1.8 – 2.6 seconds/sample (depends on sampling mode and inclusion of pressure sensor, see <i>Sample Timing</i>)		
Housing and Depth Rating	Titanium housing, 7000 m (23,000 ft) Plastic <i>ShallowCAT</i> housing, 350 m (1148 ft)		
Weight (without pressure sensor, with standard mooring guide and clamp)	<i>Titanium housing</i> - In air: 4.0 kg (8.8 lbs) In water: 2.4 kg (5.3 lbs) <i>Plastic ShallowCAT housing</i> - In air: 2.9 kg (6.4 lbs) In water: 1.3 kg (2.9 lbs)		

CAUTION:
See *Section 5: Routine Maintenance and Calibration* for handling instructions for the plastic *ShallowCAT* housing.

Dimensions

Dimensions in millimeters (inches)

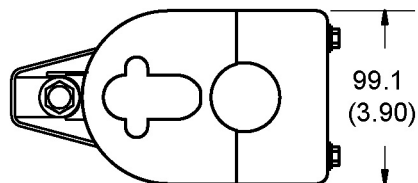
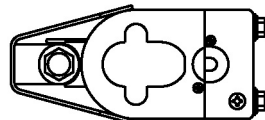
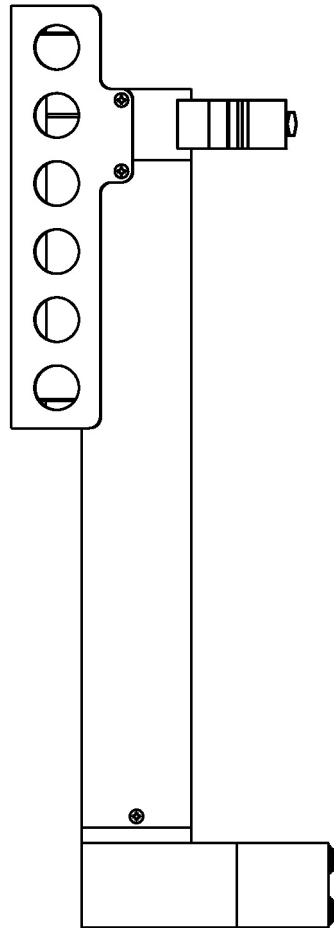
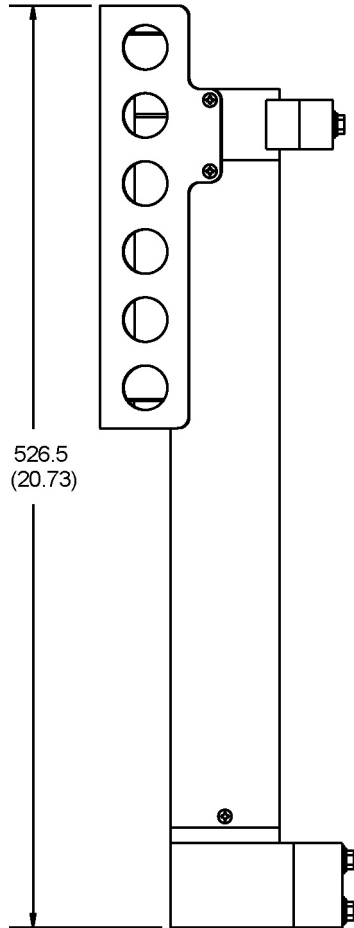
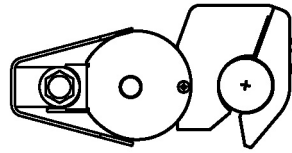
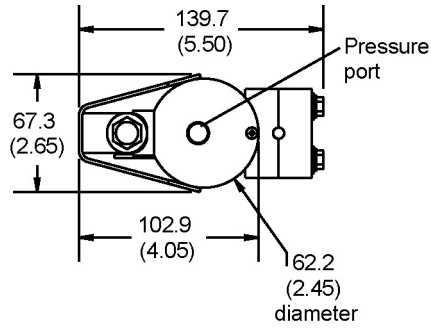

Standard Wire Guide and Mounting Clamp
(1/4 inch through 16 mm wire)

Optional Large Toroid End Cap with Wire Guide
and Heavy Duty Titanium Mounting Clamp
(38 mm wire)

Cables

Optional Internal RS-232 Data I/O Cable Wiring -- DN 33406

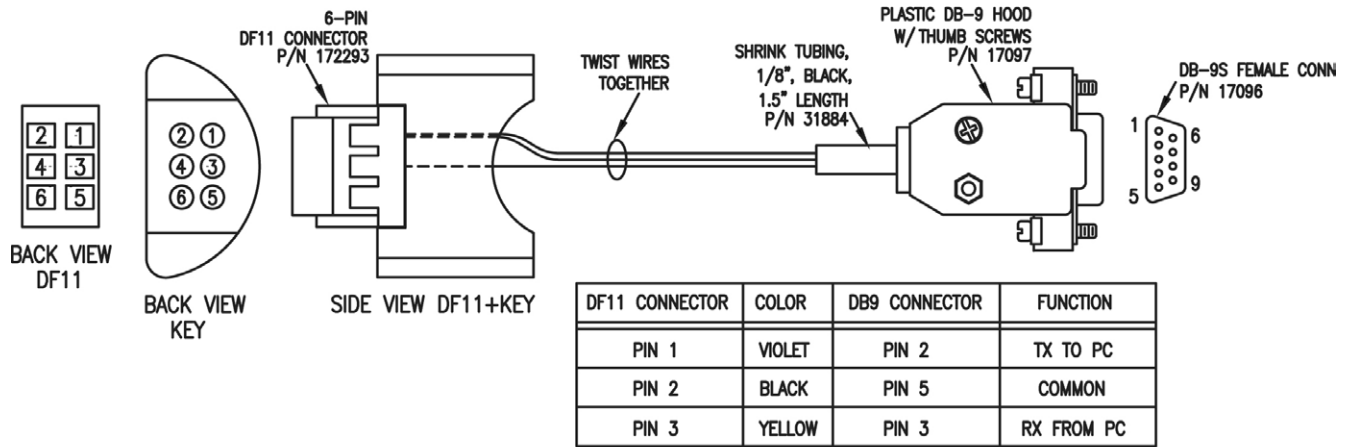

USE WITH 171887 CABLE, DB-9F TO DB-9M, 10FT.

Sample Timing

Note:

Time stored and output with the data is the time at the **start** of the sample, after a small amount of time for the MicroCAT to wake up and prepare to sample. For example, if the MicroCAT is programmed to wake up and sample at 12:00:00, the stored time will indicate 12:00:01 or 12:00:02.

Sample timing is dependent on several factors, including sampling mode and whether the MicroCAT has an optional pressure sensor.

Autonomous Sampling (time between samples = #iiSampleInterval)

Power on time for each sample while logging:

- **Without pressure:** power-on time = 1.8 seconds to sample
- **With pressure:** power-on time = 2.4 seconds sample

Polled Sampling

Time from receipt of take sample command to beginning of reply:

- **Without pressure:** power-on time = 2.0 seconds to sample
- **With pressure:** power-on time = 2.6 seconds to sample

Communications Timing, which is the time to request and transmit data from each MicroCAT to the computer/controller: 0.5 seconds.

Battery Pack Endurance

Notes:

- If the MicroCAT is logging data and the battery pack voltage is less than 6.15 volts for five consecutive scans, the MicroCAT halts logging.
- Sea-Bird recommends using the capacity value of 8.8 Amp-hours for the Saft cells as well as for the alternate cell types (Tadiran TL-4903 and Electrochem 3B0064/BCX85 AA).
- This MicroCAT uses a battery pack with a **red** cover plate. Some MicroCATs use a battery pack with a yellow cover plate; those packs are wired differently, and will not work properly in this MicroCAT.
- **See Specifications above for data storage limitations.**

The battery pack has a nominal capacity of 10.6 Amp-hours. This is lower than the Saft factory capacity rating (2.45 Amp-hours * 6 = 14.7 Amp-hours), because the cell holder includes voltage up-conversion circuitry that consumes some cell capacity. For planning purposes, to account for the MicroCAT's current consumption patterns and for environmental conditions affecting cell performance, **Sea-Bird recommends using a conservative value of 8.8 Amp-hours.**

Current consumption is as follows:

- Sampling (acquisition) current is 13 mA. Acquisition time is shown above in *Sample Timing*.
- IM communications current is 2.5 mA. Assuming the fastest practical interrogation scheme (wake all MicroCATs on mooring, send **GData**, send **Dataii** or **!iiData** to each MicroCAT, and power off all MicroCATs), the communications current is drawn for approximately 0.5 seconds **per MicroCAT on the mooring**. Each MicroCAT on the mooring draws this current while any of the MicroCATs are being queried to transmit data. Other interrogation schemes require more time.
- Quiescent current is 120 microAmps (1.1 AH per year).

So, battery pack endurance is highly dependent on the user-programmed sampling scheme. Examples are shown below. **For most cases, you can use the Deployment Endurance Calculator** to determine the maximum deployment length, instead of performing the calculations by hand.

Example 1:

10 MicroCATs with pressure are on a mooring. They are sampling autonomously every 10 minutes (6 samples/hour); the average of the samples will be requested by the computer every hour. How long can they be deployed?

Acquisition time for logging is 2.4 seconds.

Sampling current consumption = $13 \text{ mA} * 2.4 \text{ seconds sampling time} = 0.0312 \text{ Amp-sec/sample}$

In 1 hour, sampling consumption = $6 \text{ samples} * 0.0312 \text{ Amp-sec/sample} = \mathbf{0.1872 \text{ Amp-seconds/hour}}$

Communication current consumption / query = $2.5 \text{ mA} * 0.5 \text{ seconds/MicroCAT to be queried} * 10 \text{ MicroCATs on mooring} = \mathbf{0.0125 \text{ Amp-seconds/hour}}$

Quiescent current = $120 \text{ microAmps} = 0.12 \text{ mA}$

In 1 hour, quiescent current consumption $\approx 0.12 \text{ mA} * 3600 \text{ seconds/hour} = \mathbf{0.432 \text{ Amp-seconds/hour}}$

In 1 hour, the MicroCAT will take 6 samples and transmit average to computer.

Total current consumption / hour = $0.1872 + 0.0125 + 0.432 = \mathbf{0.632 \text{ Amp-sec}}$

Capacity = $(8.8 \text{ Amp-hours} * 3600 \text{ seconds/hr}) / (0.632 \text{ Amp-sec/hour}) = 50,126 \text{ hours} = 2088 \text{ days} = 5.7 \text{ years}$

However, Sea-Bird recommends that batteries should not be expected to last longer than 2 years in the field.

Number of samples = $50,126 \text{ hours} * 6 \text{ samples/hour} = 300,756 \text{ samples}$

Example 2:

Same as Example 1, but **#iDNx** command will be used once per hour to upload the last 6 samples in memory (i.e., all the samples that have been taken since the last communication). **Note that the Deployment Endurance Calculator is not compatible with this type of query; calculation by hand is required.**

Communication current = 2.5 mA

Each scan has this format: `tttt.tttt,ccc.ccccc,ppppp.ppp, dd mmm yyyy, hh:mm:ss`
(total of 54 characters, including carriage return and line feed)

Time required to upload 1 sample = $(\text{number of characters} * 10 \text{ bits/character}) / \text{baud rate} =$

$(54 * 10) / 1200 \text{ baud} = 0.45 \text{ sec/sample}$

Time required to upload 6 samples = $0.45 \text{ sec/sample} * 6 \text{ samples} = 2.7 \text{ sec}$

Communication current consumption / query = $2.5 \text{ mA} * 2.7 \text{ seconds/MicroCAT to be queried} * 10 \text{ MicroCATs on mooring} = \mathbf{0.0675 \text{ Amp-seconds/hour}}$

From above, Sampling consumption = $\mathbf{0.1872 \text{ Amp-seconds/hour}}$

From above, Quiescent consumption = $\mathbf{0.432 \text{ Amp-seconds/hour}}$

In 1 hour, the MicroCAT will take 6 samples and transmit all of them to computer.

Total current consumption / hour = $0.1872 + 0.0675 + 0.432 = 0.6867 \text{ Amp-seconds/hour}$

Capacity = $(8.8 \text{ Amp-hours} * 3600 \text{ seconds/hr}) / (0.6867 \text{ Amp-sec/hour}) = 46,133 \text{ hours} = 1922 \text{ days} = 5.2 \text{ years}$

However, Sea-Bird recommends that batteries should not be expected to last longer than 2 years in the field.

Number of samples = $46,133 \text{ hours} * 6 \text{ samples/hour} = 276,798 \text{ samples}$

Surface Inductive Modem (SIM) or Inductive Modem Module (IMM)

A Surface Inductive Modem or Inductive Modem Module is required for communication with the MicroCAT. These devices impress (*modulate*) the mooring cable with a DPSK signal that is encoded with commands received from the computer/controller. The encoded signals are *demodulated* by MicroCATs coupled to the cable. Replies from MicroCATs are similarly coupled to the cable and *demodulated* by these devices.

Surface Inductive Modem (SIM)

The SIM must be supplied with 7 to 25 volts DC power. The maximum operating current is approximately 30 milliAmps.

The user's computer or buoy controller is interfaced via RS-232 (optional RS-485) serial port to the SIM. The standard interface protocol between the computer/controller and SIM is 1200, 2400, 4800, or 9600 baud (user-selectable); 8 data bits; no parity; RS-232C; with echoing of characters.

The DPSK communication link between the SIM and IM instrument(s) is half-duplex, so talking and listening is sequential only. Although the data link between the SIM and the user's computer/controller is established at 1200, 2400, 4800, or 9600 baud, the DPSK modem communication between SIM and IM instruments always operates at 1200 baud.

See *Appendix IV: SIM Hookup and Configuration* for details.

Inductive Modem Module (IMM)

The IMM must be supplied with 7 to 24 volts DC power. The maximum operating current is approximately 15 milliAmps. When using the MicroCAT with the IMM, a minimum of 20 ohms impedance is required.

The user's computer or buoy controller is interfaced via RS-232 serial port to the IMM. The standard interface protocol between the computer/controller and IMM is 1200, 2400, 4800, 9600, 19200, or 38400 baud (user-selectable); 8 data bits; no parity; RS-232C.

The DPSK communication link between the IMM and IM instrument(s) is half-duplex, so talking and listening is sequential only. Although the data link between the IMM and the user's computer/controller is established at 1200, 2400, 4800, 9600, 19200, or 38400, the DPSK modem communication between IMM and IM instruments always operates at 1200 baud.

See the IMM Manual for details.

Mooring Cable and Wiring Requirements

Note:

For wiring, see applicable document:

- *Appendix IV: SIM Hookup and Configuration.* OR
- IMM manual.

The standard MicroCAT can mechanically accommodate mooring cables up to 16 mm (0.63 inches) in diameter. Clamps for specific diameters are available, or can be supplied on a custom basis. An optional large toroid end cap with wire guide and heavy duty titanium mounting clamp is also available for 38 mm (1.5 inch) mooring cables. Suitable mooring cables use steel wire rope with a polypropylene or polyethylene-insulating jacket. The system operates without data errors using up to 7000 meters (23,000 feet) of 3 mm (0.12 inches) or larger cable.

The mooring cable must provide connection to seawater ground below the deepest IM instrument. Terminating the wire with a metallic eye or clevis readily provides this connection.

The mooring cable must also provide for connection to the SIM or IMM.

- In a direct connection (typical cable-to-shore applications), the bottom end of the wire is grounded to seawater, and the top end remains insulated to the connection to the SIM or IMM. A second wire from the SIM or IMM connects to seawater ground, completing the circuit.
- In typical surface buoys it is often preferable to connect the jacketed mooring wire to the buoy with a length of chain, grounding the jacketed wire to seawater at each end. An Inductive Cable Coupler (ICC) connects the SIM or IMM to the jacketed wire above the uppermost IM instrument and below the point where the wire is grounded.

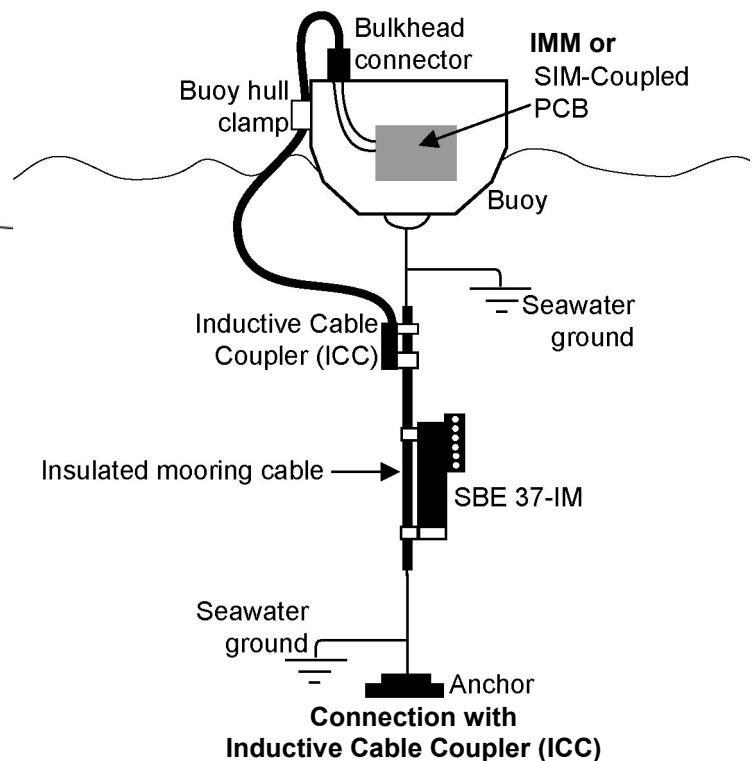
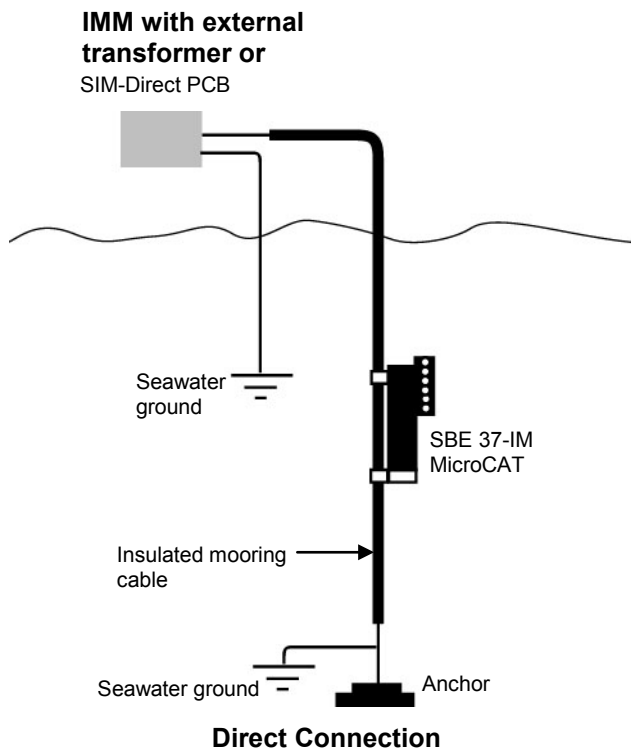

Section 3: Preparing MicroCAT for Deployment

This section describes the pre-check procedure for preparing the MicroCAT for deployment. Installation of the battery pack, testing power and communications, and setting the MicroCAT ID are discussed.

Battery Pack Installation

WARNING!

Do not ship the MicroCAT with battery pack installed. See *Shipping Precautions* in *Section 1: Introduction*.

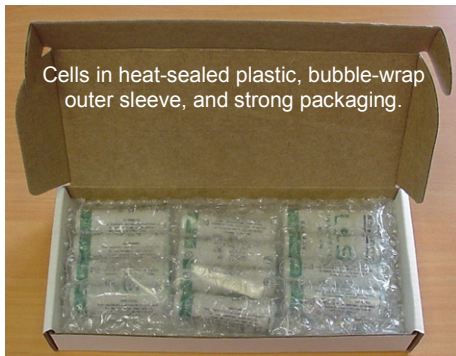

Cells in heat-sealed plastic, bubble-wrap outer sleeve, and strong packaging.

CAUTION:

See *Section 5: Routine Maintenance and Calibration* for handling instructions for the plastic *ShallowCAT* housing.

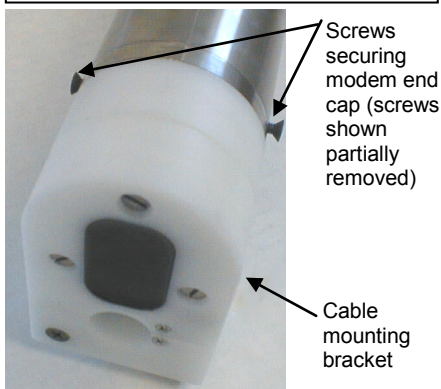

Screws securing modem end cap (screws shown partially removed)

Cable mounting bracket

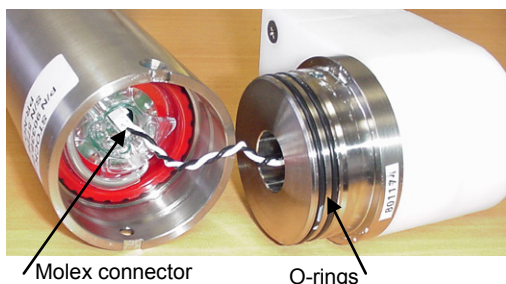

Molex connector

O-rings

Description of Cells and Battery Pack

Sea-Bird supplies twelve 3.6-volt AA lithium cells, shipped with the MicroCAT in a heat-sealed plastic bag placed in bubble wrap and a cardboard box. The empty cell holder is installed inside the MicroCAT for shipment.

No soldering is required when assembling the battery pack.

Installing Cells and Battery Pack

1. Remove the modem end cap:
 - A. Wipe the outside of the modem end cap and housing dry, being careful to remove any water at the seam between them.
 - B. Remove the 2 flat Phillips-head titanium machine screws. Do not remove any other screws from the housing.
Note: For plastic-housing MicroCATs shipped or retrofitted after July 2008, these are hex screws instead of Phillips-head screws. Sea-Bird ships the instrument with a 9/64-inch Allen wrench for these screws.
 - C. Remove the end cap by pulling firmly and steadily on the plastic cable mounting bracket/inductive coupler. It may be necessary to twist or rock the end cap back and forth or use a non-marring tool on the edge of the cap to loosen it.
 - D. The end cap is electrically connected to the electronics with a 3-pin Molex connector. Holding the wire cluster near the connector, pull gently to detach the female end of the connector from the pins.
 - E. Remove any water from the O-ring mating surfaces inside the housing with a lint-free cloth or tissue.
 - F. Put the end cap aside, being careful to protect the O-rings from damage or contamination.

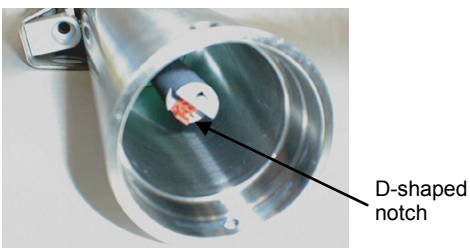
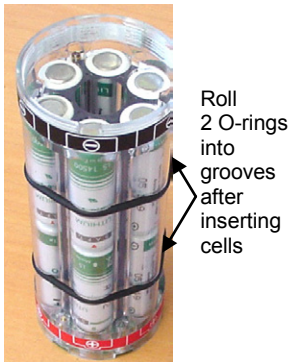
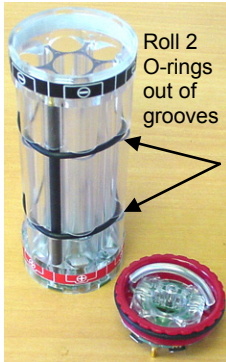
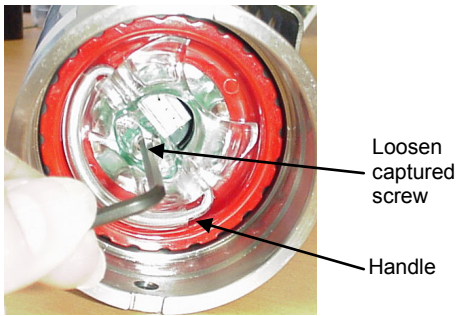

2. Remove the battery pack assembly from the housing:
 - A. Loosen the captured screw from the battery pack cover plate, using the 7/64-inch Allen wrench included with the shipment.
 - B. Lift the battery pack assembly straight out of the housing, using the handle.
3. Keep the handle in an upright position. Holding the edge of the **red** cover plate, unscrew the cover plate from the battery pack assembly.
Note: Some MicroCATs use a battery pack with a yellow cover plate; the wiring of that pack is different from this one, and **cannot be used with this MicroCAT**.
4. Roll the 2 O-rings on the outside of the battery pack out of their grooves.
5. Insert each cell into the pack, **positive end (+) first**.
6. Roll the 2 O-rings on the outside of the battery pack into place in the grooves. The O-rings compress the side of the battery pack and hold the cells tightly in place in the pack.
7. Reinstall the battery pack cover plate:
 - A. Align the pin on the battery pack cover plate PCB with the post hole in the battery pack housing.
 - B. Place the handle in an upright position. Screw the red cover plate onto the battery pack assembly. Ensure the cover is tightly screwed on to provide a reliable electrical contact.
8. Replace the battery pack assembly in the housing:
 - A. Align the D-shaped opening in the cover plate with the D-shaped notch on the shaft. Lower the assembly slowly into the housing, and once aligned, push gently to mate the banana plugs on the battery compartment bulkhead with the lower PCB. A post at the bottom of the battery compartment mates with a hole in the battery pack's lower PCB to prevent improper alignment.
 - B. Secure the assembly to the shaft with the captured screw, using the 7/64-inch Allen wrench. Ensure the screw is tight to provide a reliable electrical contact.
9. Reinstall the modem end cap:
 - A. Remove any water from the O-rings and mating surfaces in the housing with a lint-free cloth or tissue. Inspect the O-rings and mating surfaces for dirt, nicks, and cuts. Clean as necessary. Apply a light coat of O-ring lubricant (Parker Super O Lube) to O-ring and mating surfaces.
 - B. Plug the female end of the 3-pin Molex connector onto the pins, with the flat portion of the female end against the flat portion of the 'D' cutout. Verify the connector is properly aligned – a backward connection will prevent communication with the computer.
 - C. Carefully fit the end cap into the housing until the O-rings are fully seated.
 - D. Reinstall the 2 flat Phillips-head titanium screws to secure the end cap.

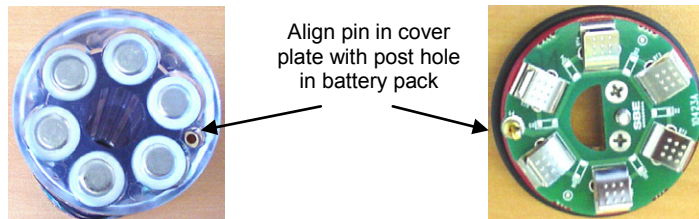

Software Installation

Notes:

- Help files provide detailed information on the software. A separate software manual on the CD-ROM contains detailed information on SBE Data Processing.
- It is possible to use the MicroCAT without the SeatermV2 terminal program by sending direct commands from a dumb terminal or terminal emulator, such as Windows HyperTerminal.
- Sea-Bird supplies the current version of our software when you purchase an instrument. As software revisions occur, we post the revised software on our FTP site. See our website (www.seabird.com) for the latest software version number, a description of the software changes, and instructions for downloading the software from the FTP site.

Seasoft V2 was designed to work with a PC running Windows XP service pack 2 or later, Windows Vista, or Windows 7.

If not already installed, install Sea-Bird software programs on your computer using the supplied software CD:

1. Insert the CD in your CD drive.
2. Install software: Double click on **SeasoftV2.exe**. Follow the dialog box directions to install the software. The installation program allows you to install the desired components. Install all the components, or just install Deployment Endurance Calculator (battery endurance calculator), SeatermV2 (terminal program *launcher* for the MicroCAT), and SBE Data Processing (data processing).

The default location for the software is c:\Program Files\Sea-Bird. Within that folder is a sub-directory for each program.

SeatermV2 Use

Note:
See SeatermV2's Help files.

1. Double click on **SeatermV2.exe**. The main screen looks like this:

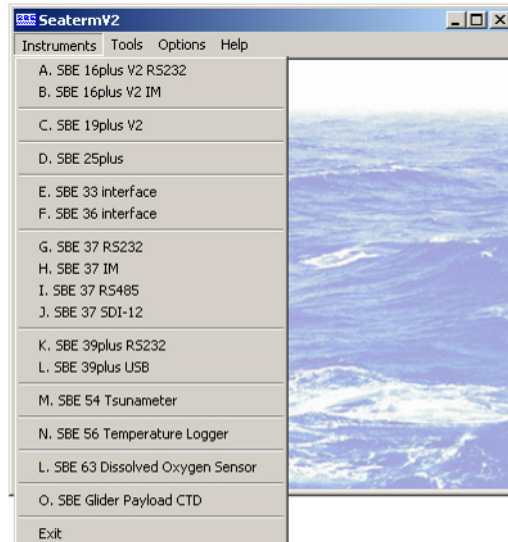

SeatermV2 is a *launcher*, and launches the appropriate terminal program for the selected instrument.

Notes:

- See SeatermIM's Help files.
- If using the MicroCAT's internal RS-232 connector to set up and/or upload data from the MicroCAT: select *SBE 37 RS232* instead of *SBE 37 IM*. This launches Seaterm232 instead of SeatermIM. Seaterm232 is similar to SeatermIM, but is optimized for RS-232 communications.

2. In the Instruments menu, select *SBE 37 IM*. **SeatermIM** opens; the main screen looks like this:

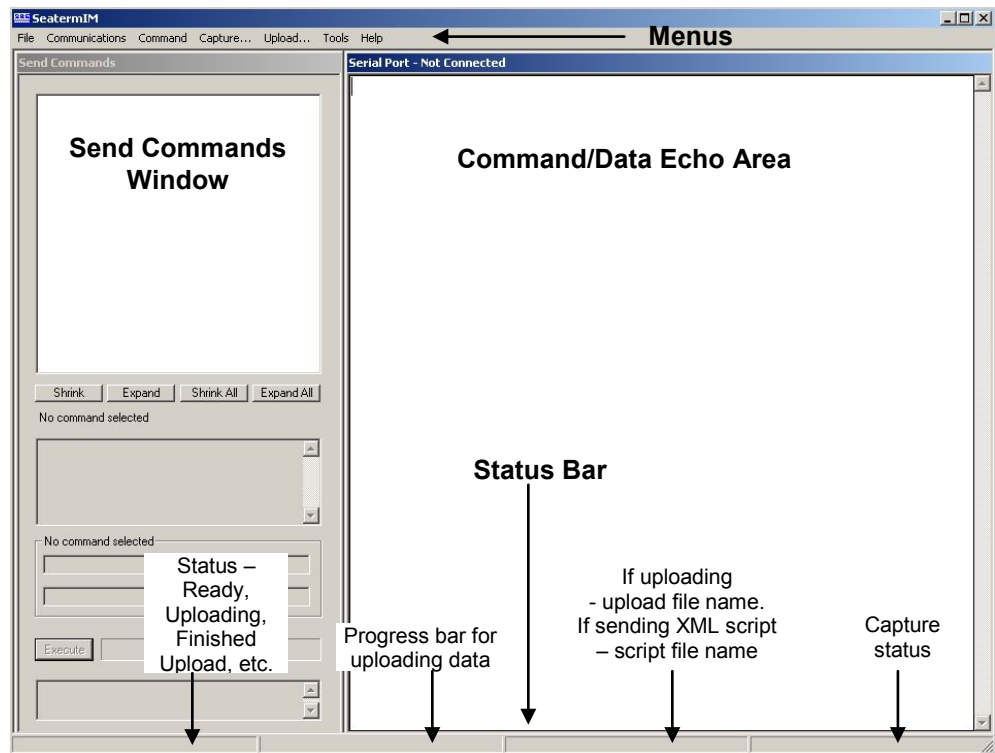

- **Menus** – For tasks and frequently executed instrument commands.
- **Send Commands window** – Contains commands applicable to your MicroCAT. The list appears after you connect to the MicroCAT.
- **Command/Data Echo Area** – Title bar of this window shows SeatermIM's current comm port and baud rate. Commands and the MicroCAT responses are echoed here. Additionally, a command can be manually typed or pasted (ctrl + V) here. Note that the MicroCAT must be *connected* and *awake* for it to respond to a command.
- **Status bar** – Provides connection, upload, script, and capture status information.

Following is a description of the menus:

Menu	Description	Equivalent Command*
File	<ul style="list-style-type: none"> • Load command file – opens selected .XML command file, and fills Send Commands window with commands. • Unload command file – closes command file, and removes commands from Send Commands window. • Exit - Exit program. 	-
Communications	<ul style="list-style-type: none"> • Configure – Establish communication parameters (comm port, baud rate, ID). • Connect – connect to comm port. Re-establish communications by sending wakeup tone to all IM instruments on line. Inductive modem instruments <i>go to sleep</i> after 2 minutes without communication from computer have elapsed. • Disconnect – disconnect from comm port • Disconnect and reconnect – may be useful if instrument has stopped responding. 	<ul style="list-style-type: none"> • PwrOn
Command	<ul style="list-style-type: none"> • Abort – interrupt and stop MicroCAT’s attempt to connect or to upload data, or sending of a script. • Send stop command - to stop logging. • Set local time– Set date and time to time sent by timekeeping software on your computer; accuracy ± 25 msec of time provided by computer. • Set UTC Time (Greenwich Mean Time) – Set date and time to time sent by timekeeping software on your computer; accuracy ± 25 msec of time provided by computer. 	<ul style="list-style-type: none"> • (press Esc key several times for Abort) • #iiStop • #iiDateTime= • #iiDateTime=
Capture	Capture instrument responses on screen to file, to save real-time data or use for diagnostics. File has .cap extension. Click Capture again to turn off capture. Capture status displays in Status bar.	—
Upload	Upload data stored in memory, in a format that Sea-Bird’s data processing software can use. Uploaded data has .xml extension, and is then automatically converted to a .hex and a .xmlcon file that can be used in SBE Data Processing’s Data Conversion module. Before using Upload: stop logging by sending #iiStop .	Several status commands and appropriate data upload command as applicable to user selection of range of data to upload (use Upload menu if you will be processing data with SBE Data Processing)
Tools	<ul style="list-style-type: none"> • Diagnostics log - Keep a diagnostics log. • Convert .XML data file – Using Upload menu automatically does this conversion; tool is available if there was a problem with the automatic conversion. • Send script – Send XML script to MicroCAT. May be useful if you have a number of MicroCATs to program with same setup. 	-

Note:
 SeatermV2 with version < 1.1 did not convert the uploaded .xml data file to a .hex and .xmlcon file. Convert .XML data file in the Tools menu was used to convert the .xml data file to a .cnv file, which could be processed in SBE Data Processing. We recommend that you update your SeatermV2 software to 1.1b or later.

*See Command Descriptions in Section 4: Deploying and Operating MicroCAT.

3. If this is the first time SeatermIM is being used, the configuration dialog box displays:

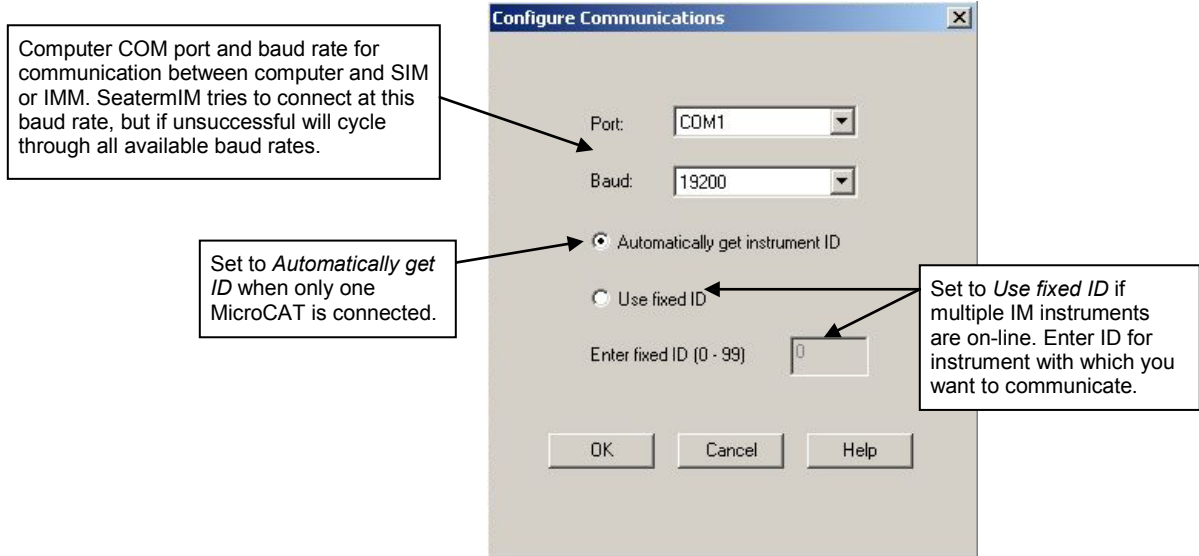

Make the desired selections, and click OK.

4. SeatermIM tries to automatically connect to the MicroCAT. It first sends commands to determine if it is connected to a SIM or an IMM, and sends the appropriate command to wake up all IM instruments on the line. The remaining connection attempt varies, depending on the configuration setting the last time SeatermIM was used:

- If SeatermIM was set to *Automatically get instrument ID* the last time it was used – SeatermIM sends **id?** and waits for a response from the MicroCAT. Once the ID response is received, SeatermIM sends **!iiGetHD** and **#iiGetHD**, using the ID provided by the MicroCAT.
- If SeatermIM was set to *Use fixed ID* the last time it was used – SeatermIM sends **!iiGetHD** and **#iiGetHD**, using the fixed ID that was entered the last time the software was used.

Note:

!iiGetHD and **#iiGetHD** provide factory-set data such as instrument type, serial number, and firmware version for the MicroCAT's communication microcontroller and acquisition microcontroller, respectively.

SeatermIM then fills the Send Commands window with the correct list of commands for your MicroCAT.

Notes:

- SeatermIM's baud rate must be the same as the IMM or SIM baud rate, as applicable. For both the SIM and the IMM, baud is factory-set to 9600, but can be changed by the user.
- Set to *Use fixed ID* to designate the appropriate MicroCAT if there are multiple IM instruments on the IM line. If desired, use *Automatically get instrument ID* if there is only one MicroCAT on the IM line. Note that the ID is stored in the MicroCAT's EEPROM and can be changed so that multiple IM instruments on a single IM line each have a unique ID. See the Configuration Sheet for the factory-set ID.

If there is no communication (no response to **id?** and/or no response to **!iiGetHD** and/or **#iiGetHD**):

- A. In the Communications menu, select *Configure*. The Configure Communications dialog box appears. Select the Comm port and baud rate for communication. Note that the factory-set baud rate is documented on the Configuration Sheet. If using a fixed ID, verify that the designated ID is correct for the MicroCAT with which you want to communicate. Click OK.
- B. In the Communications menu, select *Connect* (if *Connect* is grayed out, select *Disconnect and reconnect*). SeatermIM will attempt to connect at the baud specified in Step A, but if unsuccessful will then cycle through all other available baud rates.
- C. If there is still no communication, check cabling between the computer, SIM or IMM, and MicroCAT, and try to connect again.
- D. If there is still no communication, repeat Step A with a different comm port and/or different fixed ID, and try to connect again.

Taking a look at the Send Commands window:

The screenshot shows the 'Send Commands' window with a tree view of command categories. Callouts provide the following information:

- SIM Commands:** These commands are directed to SIM and are not preceded by any prefix. Note: If connecting to MicroCAT through IMM, IMM Commands appear in window instead of SIM Commands.
- SBE37-IM Modem Commands:** These commands are preceded by no prefix or !ii prefix, and are directed to a specific MicroCAT's **communication** microcontroller.
- SBE37-IM Commands:** These commands are preceded by #ii prefix, and are directed to a specific MicroCAT's **acquisition** microcontroller.
- Note:** Send Commands window includes commands for pump setup because 37-IMP (pumped MicroCAT) uses same firmware as 37-IM. However, these commands are not applicable to 37-IM.
- Click on desired command description in list.** (Points to 'Upload data from FLASH memory')
- Help box describes selected command in more detail.** (Points to the help text for 'GetSamples')
- Enter any command arguments (such as starting and ending sample number for upload) in these boxes.** (Points to the input fields for 'GetSamples')
- Click Execute when ready to send selected command.** (Points to the 'Execute' button)
- This box shows selected command, including ID prefix.** (Points to the '#00GetSamples:' field)

You can use the Send Commands window to send commands, or simply type the commands in the Command/Data Echo area if desired.

Power and Communications Test and Setting MicroCAT IDs – Using Surface Inductive Modem (SIM)

The power and communications test will verify that the system works, prior to deployment.

Test Setup with SIM

Note:

For testing and setup, an ICC is not required, even if using SIM-Coupled.

Notes:

- **If more than one IM instrument is on-line when you set the ID, all IM instruments will be set to the same ID.** The inductive modem receivers in IM instruments are very sensitive; two IM instruments that are side-by-side will take the same ID, even if one of them is not on the IM loop. **Therefore, separate IM instruments by at least 2 meters when setting IDs.**
- **Important! For Normal Deployed operation, reinstall the jumper across J5.**

1. Loop insulated wire through the MicroCAT's modem coupling core to simulate a mooring cable. Connect the test wire ends to the SIM's mooring cable terminals (JP4) (see *Appendix IV: SIM Hookup and Configuration*).
2. On the SIM, remove the J5 jumper (see *Appendix IV*). This inserts a 1K resistor in series with the inductive loop and reduce signal amplitude, preventing MicroCATs that are near, but not attached to, the inductive loop from responding to commands (especially important when sending *ID=).
3. Sea-Bird recommends a minimum of 20 ohms impedance to reduce noise during testing.
4. Connect the SIM to a 7-25 VDC power supply. Approximately 30 milliAmps are required. **Do not turn on the power supply yet.**
5. Connect the SIM to your computer's serial port using the 9-pin to 9-pin cable supplied with the SIM.

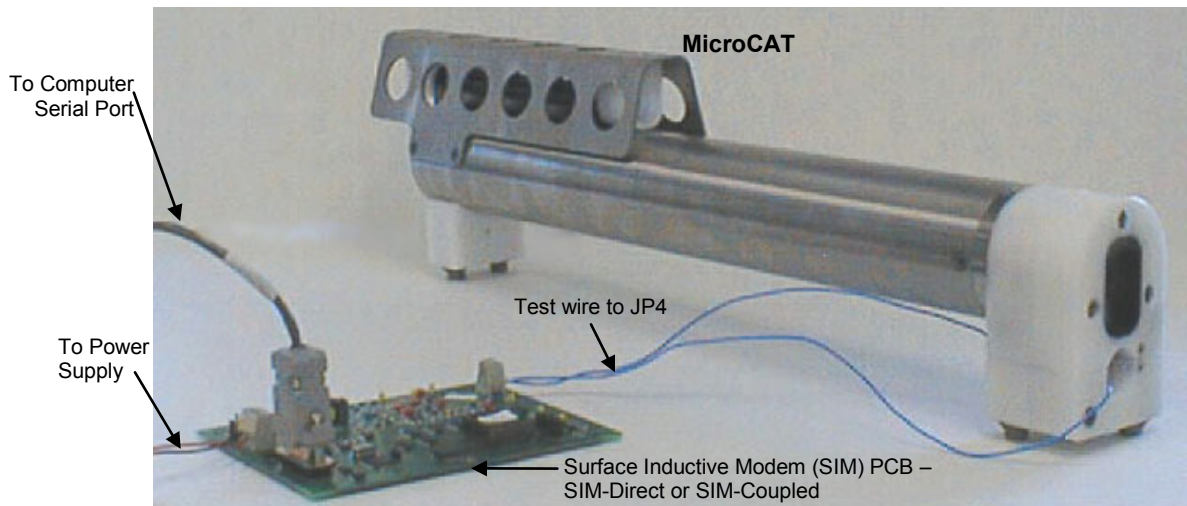

Test and Set MicroCAT ID Using MicroCAT with SIM

Note:

See SeatermV2 and SeatermIM Help files.

1. Double click on **SeatermV2.exe**. In the Instruments menu, select *SBE 37 IM*. **SeatermIM** opens.
2. If this is the first time SeatermIM is being used, the configuration dialog box displays.

Computer COM port and baud rate for communication between computer and SIM. SeatermIM tries to connect at this baud rate, but if unsuccessful will cycle through all available baud rates.

Set to *Automatically get ID* when only one MicroCAT is connected.

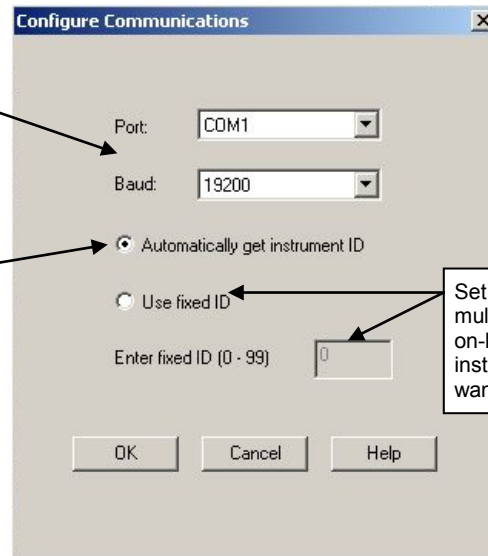

Set to *Use fixed ID* if multiple IM instruments are on-line. Enter ID for instrument with which you want to communicate.

Make the desired selections, and click OK.

3. SeatermIM tries to automatically connect to the MicroCAT. It sends **DS** to get SIM status information, and **PwrOn** to wake up all IM instruments on the line. The remaining connection attempt varies, depending on the configuration setting the last time SeatermIM was used:

- If SeatermIM was set to *Automatically get instrument ID* the last time it was used – SeatermIM sends **id?** and waits for a response from the MicroCAT. Once the ID response is received, SeatermIM sends **!iiGetHD** and **#iiGetHD**, using the ID provided by the MicroCAT.
- If SeatermIM was set to *Use fixed ID* the last time it was used – SeatermIM sends **!iiGetHD** and **#iiGetHD**, using the fixed ID that was entered the last time the software was used.

Note:

!iiGetHD and **#iiGetHD** provide factory-set data such as instrument type, serial number, and firmware version for the MicroCAT's communication microcontroller and acquisition microcontroller, respectively.

SeatermIM then fills the Send Commands window with the correct list of commands for your MicroCAT.

Notes:

- SeatermIM's baud rate must be the same as the SIM baud rate. Baud is factory-set to 9600, but can be changed by the user.
- Set to *Use fixed ID* to designate the appropriate MicroCAT if there are multiple IM instruments on the IM line. If desired, use *Automatically get instrument ID* if there is only one MicroCAT on the IM line. Note that the ID is stored in the MicroCAT's EEPROM and can be changed so that multiple IM instruments on a single IM line each have a unique ID. See the Configuration Sheet for the factory-set ID.

If there is no communication (no response to **id?** and/or no response to **!iiGetHD** and/or **#iiGetHD**):

- A. In the Communications menu, select *Configure*. The Configure Communications dialog box appears. Select the Comm port and baud rate for communication. Note that the factory-set baud rate is documented on the Configuration Sheet. If using a fixed ID, verify that the designated ID is correct for the MicroCAT with which you want to communicate. Click OK.
- B. In the Communications menu, select *Connect* (if *Connect* is grayed out, select *Disconnect and reconnect*). SeatermIM will attempt to connect at the baud specified in Step A, but if unsuccessful will then cycle through all other available baud rates.
- C. If there is still no communication, check cabling between the computer, SIM, and MicroCAT, and try to connect again.
- D. If there is still no communication, repeat Step A with a different comm port and/or different fixed ID, and try to connect again.

Note:

The SIM and MicroCAT have timeout algorithms designed to:

- restore control to the computer if an illegal command is sent
- conserve power if too much time elapses between commands

If the system does not appear to respond, send **PwrOn**. See *Timeout Descriptions* in *Section 4: Deploying and Operating MicroCAT*.

4. Display MicroCAT status information by typing **#iiDS** (ii=MicroCAT ID) and pressing the Enter key. The display looks like this:

```
SBE37-IM V 3.0e SERIAL NO. 9999 17 Oct 2012 09:00:19
vMain = 8.49, vLith = 2.84
samplenum = 0, free = 559240
logging not started
sample interval = 20 seconds
data format = converted engineering
compatible mode disabled
transmit sample number
transmit sample HEX time
pump installed = no
PC baud rate = 9600
```

5. Command the MicroCAT to take a sample by typing **#iiTS** (ii = ID) and pressing the Enter key. The display looks like this (if MicroCAT includes pressure sensor and **#iiOutputFormat=1**):

```
09999, 23.5796, 0.15269, 0.062, 17 Oct 2012, 09:01:44, 0
```

where

09999 = MicroCAT serial number 09999 (omits 037 prefix))

23.5796 = temperature in degrees Celsius

0.15269 = conductivity in S/m

0.062 = pressure in decibars

17 Oct 2012 = date

09:01:44 = time

0 = number of samples in FLASH memory; sent only if

#iiTxSampleNum=Y

These numbers should be reasonable; i.e., room temperature, zero conductivity, barometric pressure (gauge pressure), current date and time (shipped from the factory set to Pacific Daylight or Standard Time).

6. Each IM instrument on a mooring must have a unique ID for communicating with the SIM and computer. Set the ID as described below, first verifying that only one MicroCAT is on-line before you set the ID:

A. Set the MicroCAT ID by typing ***ID=ii** (ii= user-assigned ID number) and pressing the Enter key.

B. The computer responds by requesting verification, requiring you to again type ***ID=ii** and press the Enter key.

C. Record the ID for future reference.

D. In the Communications menu, select *Configure*. Set to *Use fixed ID*, enter the new ID, and click OK. This provides SeatermIM with the correct ID information for sending commands listed in the Send Commands window.

7. Send additional commands, as desired.

8. Command the MicroCAT to go to sleep (quiescent state) by typing **PwrOff** and pressing the Enter key.

The MicroCAT is ready for programming and deployment.

Important! When testing and ID setting is complete for all the IM instruments, reinstall the J5 jumper on the SIM PCB. The jumper must be installed for Normal Deployed operation.

Note:

If more than one IM instrument is on-line when you set the ID, all IM instruments will be set to the same ID. The inductive modem receivers in IM instruments are very sensitive; two IM instruments that are side-by-side will take the same ID, even if one of them is not on the IM loop. **Therefore, separate IM instruments by at least 2 meters when setting IDs.**

Power and Communications Test and Setting MicroCAT IDs – Using Inductive Modem Module (IMM)

The power and communications test will verify that the system works, prior to deployment.

Test Setup with IMM

1. Loop insulated wire through the MicroCAT's modem coupling core to simulate a mooring cable. Place the other end of the loop through the IMM test coupler (supplied with the IMM) or the ICC. Connect the wire ends from the IMM test coupler or ICC to the IMM's mooring cable terminals (J1) (see IMM Manual).
2. Sea-Bird recommends a minimum of 20 ohms impedance to reduce noise during testing.
3. Connect the IMM to your computer's serial port and to a 7 – 24 VDC power supply using the cable supplied with the IMM. A maximum of 15 mA is required.

Note:

If more than one IM instrument is on-line when you set the ID, all IM instruments will be set to the same ID. The inductive modem receivers in IM instruments are very sensitive; two IM instruments that are side-by-side will take the same ID, even if one of them is not on the IM loop. **Therefore, separate IM instruments by at least 2 meters when setting IDs.**

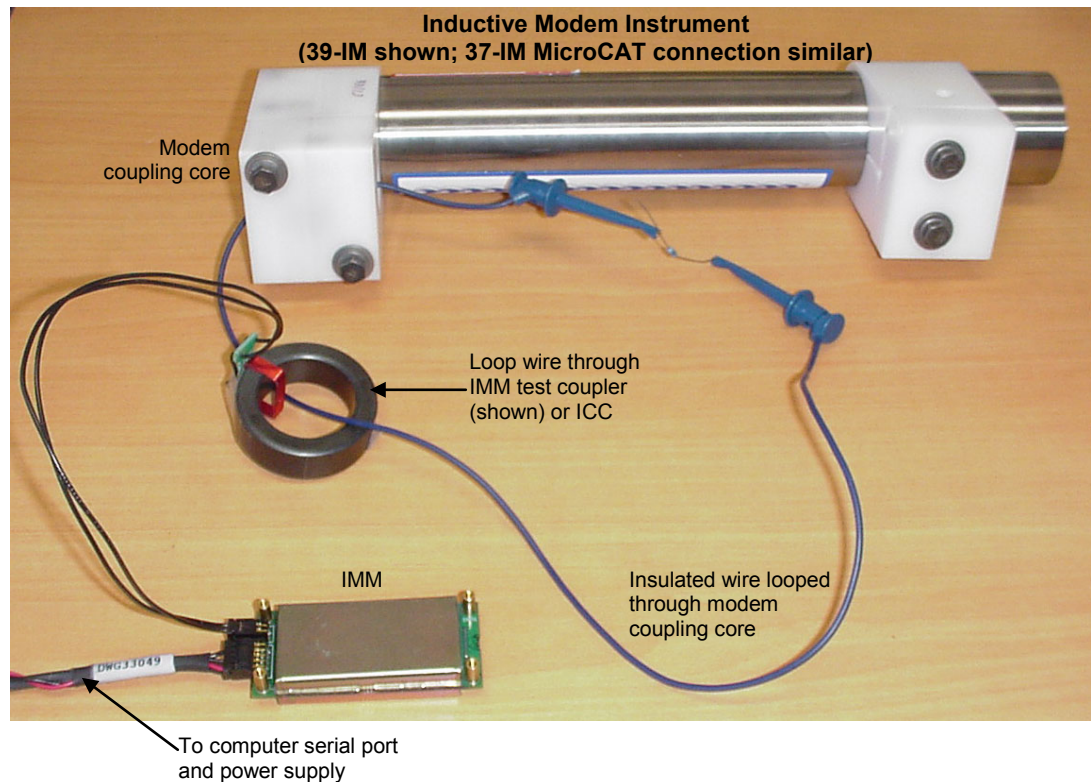

Setup of IMM for use with MicroCAT

Note:

See the IMM manual for complete details on the use and setup of the IMM.

Sea-Bird recommends **one** of the following setups of the IMM for use with the MicroCAT:

To make full use of IMM capabilities:

***Init**

***Init** (Resets IMM to factory default state [must be sent twice])

SetConfigType=2

SetEnableAutoIMFlag=0

SetEnableBackSpace=1

SetEnableBinaryData=0

SetEnableEcho=1

SetEnableHostFlagConfirm=0

SetEnableHostFlagTerm=0

SetEnableHostFlagWakeup=0

SetEnableHostPromptConfirm=0

SetEnableHostServeOnPwrUp=1

SetEnablePrompt=1

SetEnableHostWakeupCR=0

SetEnableSignalDetector=0

SetTermFromHost=36

SetTermToHost=13

To have the IMM emulate the SIM:

***Init**

***Init** (Resets IMM to factory default state [must be sent twice])

SetConfigType=1

SetEnableBinaryData=0

Verify that the IMM is set up as described by sending the **GetCD** command before proceeding with the MicroCAT setup.

A script including one of the above setups should be included in the buoy controller, to allow the IMM to be reset to the appropriate state if it becomes corrupted.

Test and Set MicroCAT ID Using MicroCAT with IMM

Note:

See SeatermV2 and SeatermIM Help files.

1. Double click on **SeatermV2.exe**. In the Instruments menu, select *SBE 37 IM*. **SeatermIM** opens.
2. If this is the first time SeatermIM is being used, the configuration dialog box displays.

Computer COM port and baud rate for communication between computer and IMM. SeatermIM tries to connect at this baud rate, but if unsuccessful will cycle through all available baud rates.

Set to *Automatically get ID* when only one MicroCAT is connected.

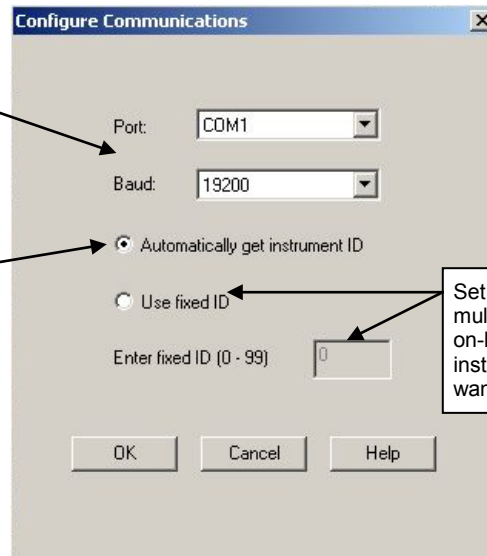

Set to *Use fixed ID* if multiple IM instruments are on-line. Enter ID for instrument with which you want to communicate.

Make the desired selections, and click OK.

3. SeatermIM tries to automatically connect to the MicroCAT. It sends **DS** to determine if it is communicating with a SIM. If there is no response to **DS**, it assumes it is communicating with an IMM and proceeds as follows.
 - A. It sends **GetHD** to get IMM status information.
 - B. If **ConfigType=1**, it sends **PwrOn** to wake up all IM instruments on the line. If **ConfigType=2**, it sends **ForceCaptureLine** to reserve the IM line by transmitting a carrier signal, and **SendWakeupTone** to wake up all IM instruments on the line.
 - C. The remaining connection attempt varies, depending on the configuration setting the last time SeatermIM was used:
 - If SeatermIM was set to *Automatically get instrument ID* – It sends **id?** and waits for a response from the MicroCAT. It then sends **!iiGetHD** and **#iiGetHD**, using the ID provided by the MicroCAT.
 - If SeatermIM was set to *Use fixed ID* – It sends **!iiGetHD** and **#iiGetHD**, using the fixed ID that was entered the last time SeatermIM was used.

SeatermIM then fills the Send Commands window with the correct list of commands for your MicroCAT.

Note:

!iiGetHD and **#iiGetHD** provide factory-set data such as instrument type, serial number, and firmware version for the MicroCAT's communication microcontroller and acquisition microcontroller, respectively.

Notes:

- SeatermIM's baud rate must be the same as the IMM baud rate. Baud is factory-set to 9600, but can be changed by the user.
- Set to *Use fixed ID* to designate the appropriate MicroCAT if there are multiple IM instruments on the IM line. If desired, use *Automatically get instrument ID* if there is only one MicroCAT on the IM line. Note that the ID is stored in the MicroCAT's EEPROM and can be changed so that multiple IM instruments on a single IM line each have a unique ID. See the Configuration Sheet for the factory-set ID.

4. **If there is no communication** (no response to **id?** and/or no response to **!iiGetHD** and/or **#iiGetHD**):
 - A. In the Communications menu, select *Configure*. The Configure Communications dialog box appears. Select the Comm port and baud rate for communication. Note that the factory-set baud rate is documented on the Configuration Sheet. If using a fixed ID, verify that the designated ID is correct for the MicroCAT with which you want to communicate. Click OK.
 - B. In the Communications menu, select *Connect* (if *Connect* is grayed out, select *Disconnect and reconnect*). SeatermIM will attempt to connect at the baud specified in Step A, but if unsuccessful will then cycle through all other available baud rates.
 - C. If there is still no communication, check cabling between the computer, IMM, and MicroCAT, and try to connect again.
 - D. If there is still no communication, repeat Step A with a different comm port and/or different fixed ID, and try to connect again.

Note:

The IMM and MicroCAT have timeout algorithms designed to:

- restore control to the computer if an illegal command is sent
- conserve power if too much time elapses between commands

If the system does not appear to respond:

- If **ConfigType=1**: send **PwrOn**.
- If **ConfigType=2**: wait at least 1 second, send **ForceCaptureLine**, and send **SendWakeUpTone**.

See *Timeout Descriptions* in *Section 4: Deploying and Operating MicroCAT* and the IMM manual.

5. Display MicroCAT status information by typing **#iiDS** (ii=MicroCAT ID) and pressing the Enter key. The display looks like this:

```
SBE37-IM V 3.0e SERIAL NO. 9999 17 Oct 2012 09:00:19
vMain = 8.49, vLith = 2.84
samplenum = 0, free = 559240
logging not started
sample interval = 20 seconds
data format = converted engineering
compatible mode disabled
transmit sample number
transmit sample HEX time
pump installed = no
PC baud rate = 9600
```

6. Command the MicroCAT to take a sample by typing **#iiTS** (ii = ID) and pressing the Enter key. The display looks like this (if MicroCAT includes pressure sensor and **#iiOutputFormat=1**):

```
09999, 23.5796, 0.15269, 0.062, 17 Oct 2012, 09:01:44, 0
```

where

09999 = MicroCAT serial number 09999 (omits 037 prefix))

23.5796 = temperature in degrees Celsius

0.15269 = conductivity in S/m

0.062 = pressure in decibars

17 Oct 2012 = date

09:01:44 = time

0 = number of samples in FLASH memory; sent only if

#iiTxSampleNum=Y

These numbers should be reasonable; i.e., room temperature, zero conductivity, barometric pressure (gauge pressure), current date and time (shipped from the factory set to Pacific Daylight or Standard Time).

7. Each IM instrument on a mooring must have a unique ID for communicating with the IMM and computer. Set the ID as described below, first verifying that only one MicroCAT is on-line before you set the ID:

- A. Set the MicroCAT ID by typing ***ID=ii** (ii= user-assigned ID number) and pressing the Enter key.
- B. The computer responds by requesting verification, requiring you to again type ***ID=ii** and press the Enter key.
- C. Record the ID for future reference.
- D. In the Communications menu, select *Configure*. Set to *Use fixed ID*, enter the new ID, and click OK. This provides SeatermIM with the correct ID information for sending commands listed in the Send Commands window.

8. Send additional commands, as desired.

9. Command the MicroCAT to go to sleep (quiescent state) by typing **PwrOff** and pressing the Enter key.

The MicroCAT is ready for programming and deployment.

Note:

If more than one IM instrument is on-line when you set the ID, all IM instruments will be set to the same ID. The inductive modem receivers in IM instruments are very sensitive; two IM instruments that are side-by-side will take the same ID, even if one of them is not on the IM loop. **Therefore, separate IM instruments by at least 2 meters when setting IDs.**

Section 4:

Deploying and Operating MicroCAT

This section includes a discussion of system operation, example sets of operation commands, and detailed command descriptions and data output formats. It also provides instructions for deploying and recovering the MicroCAT, and uploading and processing data from the MicroCAT's memory.

Operation Description

The MicroCAT's internal functions are supervised by two internal microcontrollers. The acquisition microcontroller supervises measurement acquisition, and setup and sampling functions. The communication (modem) microcontroller supervises communication between the MicroCAT and SIM or IMM. These two microcontrollers allows for independent control of power usage by the communication and acquisition circuits. Acquisition consumes more power, but for shorter duration. Communication protocols take proportionately more time, but can be controlled separately and operate at lower power, thus maximizing battery life. This also prevents communication protocols from interfering with measurement acquisition timing.

Commands sent to the SIM or IMM (both typically at the surface) can be directed to the SIM or IMM, the MicroCAT communication microcontroller, or the MicroCAT acquisition microcontroller. A command prefix (ID) is used to direct commands to a MicroCAT with the same ID (**!i** prefix to the communication microcontroller, **#ii** prefix to the acquisition microcontroller). Global commands do not require a prefix and are recognized by all MicroCATs attached to the same inductive cable.

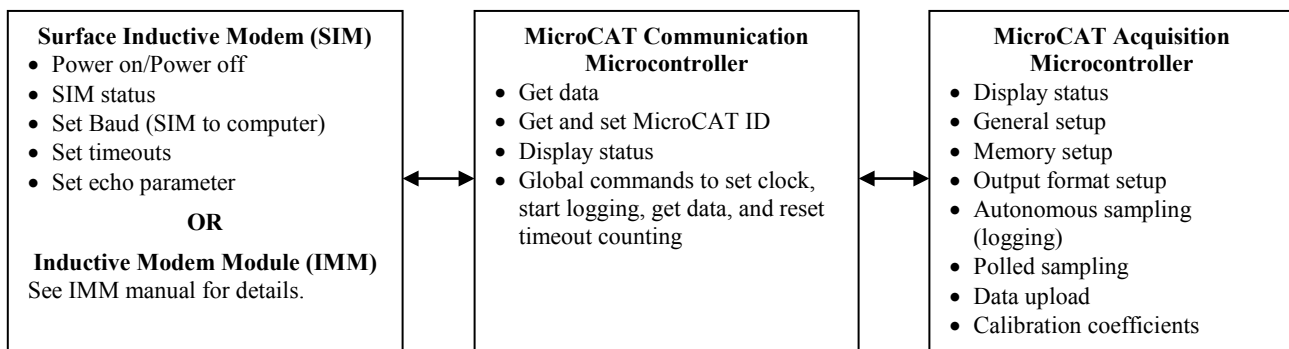

Each time a command is sent that wakes up the MicroCAT's acquisition microcontroller:

1. The MicroCAT responds to the transmitted command, and
2. The acquisition microcontroller goes back to sleep (quiescent state).

Timeout Descriptions

For **IMM timeouts**, see the IMM manual.

SIM timeouts restore control to the computer if no reply is received from the MicroCAT (for example, upon sending an illegal command) within a specified length of time. This allows new commands to be sent. There are two user-programmable SIM timeouts that are applicable for use with the MicroCAT:

- **DataNMax** – timeout for **Dataii** or **!iiData** only.
Default 1000 milliseconds.

- **RelayMax** – timeout for all other commands. Default 20 seconds.

When using RS-232 between the SIM and computer, control of the SIM can be re-established sooner than the timeout by pressing the Esc key and then the Enter key. When control is reestablished, new commands can be sent.

The MicroCAT timeout powers down the MicroCAT communication circuits if the MicroCAT does not receive a command for 2 minutes, to prevent battery exhaustion. **To re-establish control:**

- Select *Connect* in SeatermIM's Communications menu, or
- (if using the SIM) Send **PwrOn**, or
- (if using the IMM) Wait at least 1 second, send **ForceCaptureLine**, and then send **SendWakupTone**.

Sampling Modes

The MicroCAT has four basic sampling modes for obtaining data on temperature, conductivity, and optional pressure:

- Polled Sampling
- Autonomous Sampling
- Combo Sampling
- Averaging Sampling

Commands can be used in various combinations and in one or more sampling modes to provide a high degree of operating flexibility. Review the operation of the four basic sampling modes and the commands described in *Command Descriptions* before setting up your system.

Descriptions and examples of the sampling modes follow for a system with three MicroCATs (IDs 01, 02, and 03) on a mooring cable. Note that the MicroCAT's response to each command is not shown in the examples.

Polled Sampling

On command, the MicroCAT takes one sample of data and sends the data to the SIM or IMM. Storing of data in the MicroCAT's FLASH memory is dependent on the particular command used. Note that it is not possible to synchronize the data samples from each MicroCAT in polled sampling.

Example: Polled Sampling (user input in bold)

Send wakeup tone to all MicroCATs. Globally set current date and time to December 1, 2012 9 am. For each MicroCAT: set up to output data in converted engineering units. After all parameters are entered, verify setup. Send power-off command to all MicroCATs.

(Select *Connect* in SeatermIM's Communications menu to connect and wake up all MicroCATs.)

DATE TIME=12012012090000

#01OUTPUTFORMAT=1

#01GETCD (to verify setup)

(repeat **#iiOUTPUTFORMAT=1** through **#iiGETCD** for MicroCATs 02 and 03)

PWROFF

Send wakeup tone to all MicroCATs. Command each MicroCAT to take a sample, and send converted data to SIM/IMM. Send power-off command to all MicroCATs.

(Select *Connect* in SeatermIM's Communications menu to connect and wake up all MicroCATs.)

#01TS (MicroCAT 01 takes and transmits a sample.)

#02TS (MicroCAT 02 takes and transmits a sample.)

#03TS (MicroCAT 03 takes and transmits a sample.)

PWROFF

Autonomous Sampling (Logging commands)

Notes:

- If the FLASH memory is filled to capacity, autonomous sampling stops (i.e., the MicroCAT does not overwrite the data in memory).
- Use **#iiStop** to:
 - stop logging.
 - stop waiting to start logging (after **#iiStartLater** has been sent).
 Once **#iiStop** is sent, the MicroCAT will accept all commands again.

The MicroCAT samples data at pre-programmed intervals, defined by **#iiSampleInterval**. For each sample, the MicroCAT wakes up, samples, stores the data in its FLASH memory, and goes to sleep (enters quiescent state). The MicroCAT does not transmit data to the SIM or IMM. Logging is started with **ResumeLogging**, **GData**, **#iiStartNow**, **#iiStartLater**, or **#iiGA**. Logging is stopped with **#iiStop**.

To synchronize the data samples for each MicroCAT in Autonomous Sampling (see *Specifications* in *Section 2: Description of MicroCAT* for the real-time clock specifications):

1. Send a global command to set the date and time for all the MicroCATs to the same value.
2. Set the sampling interval for each MicroCAT to the same value.
3. Set the delayed logging start date and time for each MicroCAT to the same value, and then send **#iiStartLater**, **or** Start logging now using the global **ResumeLogging** or **GData** command.

The MicroCAT has a *lockout* feature to prevent unintended interference with sampling. If the MicroCAT is logging or is waiting to start logging (**#iiStartLater** has been sent, but logging hasn't started yet), only the following commands will be accepted:

- All SIM or IMM commands,
- These MicroCAT Communication Microcontroller commands: **GData**, **Dataii**, **!iiData**, **ID?**, **!iids**
- These MicroCAT Acquisition Microcontroller commands: **#iiDS**, **#iiDC**, **#iiTS**, **#iiTSR**, **#iiSL**, **#iiSLT**, **#iiSLTR**, **#iiGA**, **#iiSACG**, **#iiSARG**, **#iiSAC**, **#iiSAR**, **#iiSS**, **#iiDNx**, and **#iiStop**.

Example: Autonomous Sampling (user input in bold).

Send wakeup tone to all MicroCATs. Globally set current date and time to December 1, 2010 9 am.

For each MicroCAT: initialize logging to overwrite previous data in FLASH memory, and set up to take samples every 10 seconds and start on 3 December 2012 at 12:00:00.

(Select *Connect* in SeatermIM's Communications menu to connect and wake up all MicroCATs.)

DATETIME=12012010090000

#01INITLOGGING

#01SAMPLEINTERVAL=10

#01STARTDATETIME=12032012120000

#01STARTLATER

#01GETCD (To verify setup.)

(repeat **#iiINITLOGGING** through **#iiGETCD** for MicroCATs 02 and 03)

PWROFF

When ready to upload all data to computer, wake up all MicroCATs, stop sampling, and upload data:

(Select *Connect* in SeatermIM's Communications menu to connect and wake up all MicroCATs.)

#01STOP

(Click Upload menu – SeatermIM leads you through screens to define data to be uploaded and where to store it)

(repeat **#iiSTOP** through Upload for MicroCATs 02 and 03)

PWROFF

Combo Sampling

Combo Sampling combines Autonomous Sampling with the ability to retrieve the last stored data sample from each MicroCAT, to allow the user to look at some data without stopping the sampling. As in Autonomous Sampling, at pre-programmed intervals the MicroCAT wakes up, samples data, stores the data in its FLASH memory, and goes to sleep (enters quiescent state).

When desired, the user can request the last stored data sample from a particular MicroCAT.

Example: Combo Sampling (user input in bold)

Send wakeup tone to all MicroCATs. Globally set current date and time to December 1, 2012 9 am.

For each MicroCAT: initialize logging to overwrite previous data in FLASH memory, and set up to take samples every 10 seconds and start on 3 December 2012 at 12:00:00.

(Select *Connect* in SeatermIM's Communications menu to connect and wake up all MicroCATs.)

DATETIME=12012012090000

#01INITLOGGING

#01SAMPLEINTERVAL=10

#01STARTDATETIME=12032012120000

#01STARTLATER

#01GETCD (To verify setup.)

(repeat **#iiINITLOGGING** through **#iiGETCD** for MicroCATs 02 and 03)

PWROFF

After logging begins, look at data from last sample to check results:

(Select *Connect* in SeatermIM's Communications menu to connect and wake up all MicroCATs.)

#01SL

#02SL

#03SL

PWROFF

When ready to upload all data to computer, wake up all MicroCATs, stop sampling, and upload data:

(Select *Connect* in SeatermIM's Communications menu to connect and wake up all MicroCATs.)

#01STOP

(Click Upload menu – SeatermIM leads you through screens to define data to be uploaded and where to store it)

(repeat **#iiSTOP** through Upload for MicroCATs 02 and 03)

PWROFF

Averaging Sampling

Averaging Sampling combines Autonomous Sampling with the ability to retrieve averaged data from each MicroCAT, to allow the user to look at averaged data without stopping sampling. As in Autonomous Sampling, at pre-programmed intervals the MicroCAT wakes up, samples data, stores the data in its FLASH memory, and goes to sleep (enters quiescent state). As the MicroCAT is sampling, it automatically adds the data values (C, T, and optional P) for each sample to an *averaging section* in the FLASH memory, and keeps track of the number of samples since the last averaging request. When desired, the user can globally request the average of the data sampled since the last request. Each MicroCAT gets the data from the averaging section in FLASH, divides the sums by the number of samples, holds the averaged data (C, T, and optional P) in a buffer, and resets the averaging section to begin a new average. The user can then request the averaged data from a particular MicroCAT.

Note:

Sending **GData** resets the logging time base. The next sample is taken at **#iiSampleInterval/2** after the MicroCAT receives **GData**.

Example: Averaging Sampling (user input in bold)

Send wakeup tone to all MicroCATs. Globally set current date and time to December 1, 2012 9 am.

For each MicroCAT: initialize logging to overwrite previous data in FLASH memory, and set up to take samples every 10 seconds and start on 3 December 2012 at 12:00:00.

(Select *Connect* in SeatermIM's Communications menu to connect and wake up all MicroCATs.)

DATETIME=12012012090000

#01INITLOGGING

#01SAMPLEINTERVAL=10

#01STARTDATETIME=12032012120000

#01STARTLATER

#01GETCD (To verify setup)

(repeat **#iiINITLOGGING** through **#iiGETCD** for MicroCATs 02 and 03)

PWROFF

After logging begins, send the global command to calculate average data and start a new average for each MicroCAT. Then send the command to each MicroCAT to transmit the averaged data.

(Select *Connect* in SeatermIM's Communications menu to connect and wake up all MicroCATs.)

GDATA

DATA01

DATA02

DATA03

PWROFF

When ready to upload all data to computer, wake up all MicroCATs, stop sampling, and upload data:

(Select *Connect* in SeatermIM's Communications menu to connect and wake up all MicroCATs.)

#01STOP (

(Click Upload menu – SeatermIM leads you through screens to define data to be uploaded and where to store it)

(repeat **#iiSTOP** through Upload for MicroCATs 02 and 03)

PWROFF

Command Descriptions

Notes:

- If using the MicroCAT with a **Surface Inductive Modem (SIM)**, the SIM commands are included in this manual.
- If using the MicroCAT with an **Inductive Modem Module (IMM)**, see the IMM manual for details on IMM commands.

This section describes commands and provides sample outputs. See *Appendix III: Command Summary* for a summarized command list.

When entering commands:

- Input commands to the MicroCAT in upper or lower case letters and register commands by pressing the Enter key. Note that commands are shown with a mix of upper and lower case for ease in reading (for example, **#iiInitLogging**), but do not need to be entered that way.
- The MicroCAT sends an error message if an invalid command is entered.
- (If **#iiOutputExecutedTag=N**) If the system does not return an *S>* prompt after executing a command, press the Enter key to get the *S>* prompt.
- Commands to enable a parameter (such as enabling output of the sample number with the data) can be entered with the *argument* as Y or 1 for yes, and N or 0 for no (for example, **#iiTxSampleNum=y** and **#iiTxSampleNum=1** are equivalent; both enable the sample number output).
- If a new command is not received within 2 minutes after the completion of a command, the MicroCAT communication microcontroller returns to the quiescent (sleep) state.
- If in quiescent state, re-establish communications by selecting *Connect* in SeatermIM's Communications menu, or
 - (if using SIM) sending **PwrOn**.
 - (if using IMM set to **ConfigType=1**) sending **PwrOn**.
 - (if using IMM set to **ConfigType=2**) waiting at least 1 second, sending **ForceCaptureLine**, and sending **SendWakeUpTone**.
- When sampling autonomously, the MicroCAT responds only to commands that do not change its setup or interfere with sampling (see *Autonomous Sampling* above for command list). If you wake it while sampling (for example, to send **#iiDS** to check sampling progress), it temporarily stops sampling. Sampling resumes when it goes back to sleep again (after 2-minute timeout).
- When waiting to sample autonomously (**#iiStartLater** has been sent), the MicroCAT responds only to commands that do not change its setup or interfere with sampling (see *Autonomous Sampling* above for command list). To send any other commands, send **#iiStop**, send the desired commands to modify the setup, and then send **#iiStartLater** again.
- If desired, you can set up and/or upload data from the MicroCAT using the internal RS-232 connector and the optional data I/O cable (PN 801836). If used in this way, omit the **#ii** prefix in the Acquisition Microcontroller commands, and use Seaterm232 instead of SeatermIM (select *SBE 37 RS232* in SeatermV2's Instrument menu). See *Upload Using RS-232 (Serial Mode) Telemetry* in *Section 4: Deploying and Operating MicroCAT* to access the connector and for upload details.
- To assist customers who have MicroCATs with digital firmware < 3.0, as well as the newer MicroCATs documented in this manual, Sea-Bird retained a number of the old commands in the new firmware. You can use those commands as an alternative to the commands documented below; see *Appendix V: Old-Style Compatible Commands*.

SIM Commands

SIM commands are directed to the Surface Inductive Modem, to set it up for operation with the MicroCAT.

Power-On Commands

PwrOn	Send wakeup tone to all IM instruments on-line.
PwrOff	Send power-off command to all IM instruments on-line. Main power turned off and IM instruments placed in quiescent (sleep) state. Logging and memory retention not affected.

Note:

AutoPwrOn=N is typically used only with a *Tone Detect* board system for an SBE 44 Underwater Inductive Modem.

AutoPwrOn=x	<p>x=Y (default): Automatically send PwrOn to all IM instruments on-line when power applied to SIM. This wakes up all IM instruments on-line.</p> <p>x=N: Do not send PwrOn when power applied to SIM.</p>
--------------------	--

Status Command

DS	Display SIM firmware version and setup. Example includes commands used to modify parameters [in parentheses].
-----------	---

Example: (user input in bold, command used to modify parameter in parentheses)

```

DS
SBE 37 SURFACE MODEM V 3.0a
wait time for dataNN response = 1000 msec           [DataNNMax=]
wait time for relay command response = 20 seconds    [RelayMax=]
binary relay character timeout = 1000 msec           [not applicable to MicroCAT]
echo = yes                                           [EchoOn or EchoOff]
execute pwr on command on powerup = yes             [AutoPwrOn=]

```

Communications Commands

Note:

The SIM's baud rate (set with **Baud=**) must be the same as SeatermIM's baud rate (set in *Configure* in the Communications menu). After you send **Baud=**, you must disconnect and reconnect (in the Communications menu, select *Disconnect and reconnect*) to communicate at the new baud rate.

Baud=x

x= baud rate between SIM and computer / controller (1200, 2400, 4800, or 9600).
Default 9600.

Note:

If outputting data in XML format (**#iiOutputFormat=4**), Sea-Bird recommends setting **DataNNmax=** to 4000 milliseconds.

DataNNMax=x

x= timeout (0-32767 milliseconds; SIM rounds down to nearest 50 milliseconds) that applies to **Dataii** or **!iiData** only. If no reply received within **DataNNMax**, control returned to computer and other commands can be sent. Default 1000 milliseconds.

RelayMax=x

x= timeout (0-3276 seconds) that applies to all commands other than **Dataii** or **!iiData**. If no reply received within **RelayMax**, control returned to computer and other commands can be sent. Default 20 seconds.

EchoOn

Echo characters received from computer (default) - monitor shows entered commands as you type.

EchoOff

Do not echo characters received from computer - monitor does not show entered commands as you type.

MicroCAT Communication Microcontroller Commands

Global Commands

DateTime=

mmddyyyyhhmmss

Set real-time clock month, day, year, hour, minute, second for **all** MicroCATs.

When using IMM with either ConfigType:

Use **#iiDateTime=** to set clock in each individual MicroCAT. **DateTime=** does not work.

Example: Set current date and time for all MicroCATs on-line to 10 January 2012 12:00:00 (user input in bold).

DATEIME=01102012120000

ResumeLogging

Simultaneously command **all** MicroCATs to start logging. First sample will be taken after delay of **#iiSampleInterval**.

Notes:

- Either **ResumeLogging** or **GData** can be used to simultaneously start logging in all MicroCATs.
- If the MicroCAT is logging, taking a sample every **#iiSampleInterval** seconds, sending **GData** resets the logging time base. The next sample is taken at the current time plus (**#iiSampleInterval/2**). This reset occurs each time that **GData** is sent (see example).

GData

Simultaneously command **all** communication microcontrollers to get **average** data from acquisition units, (re)start logging, and start next averaging cycle. Communication microcontrollers hold averaged data in a buffer until receiving **Dataii** or **!iiData**. Next sample will be taken after delay of (**#iiSampleInterval/2**).

When using IMM with ConfigType=2:

Use **SendGData** instead; this results in IMM sending **GData** to all IM instruments online.

Example: **#iiSampleInterval=600** (10 minutes)

Hr	min	sec	
00	00	00	GData received
00	05	00	Sample at #iiSampleInterval/2 from when GData received
00	15	00	Sample
00	18	00	GData received (average 2 data sets)
00	23	00	Sample at #iiSampleInterval/2 from when GData received
00	33	00	Sample
00	43	00	Sample
...			

StayOn

Command **all** MicroCATs to reset counting for 2-minute timeout, preventing individual MicroCATs from going to sleep while you are communicating with another MicroCAT on mooring.

Get Data Command

Note:

The setting for **#iiCompatibleMode=** affects the date format for output if **#iiOutputFormat=2** or **#iiFormat=2**

!iiData or **Dataii**

Get **averaged data** obtained with **GData** from MicroCAT with ID = ii, in format specified by **#iiOutputFormat=**. Number of samples in average is appended to end of data string. String is preceded by MicroCAT ID.

When using IMM with either ConfigType:
Use **!iiData**. **Dataii** does not work.

MicroCAT ID Commands

Only one IM instrument can be on line when sending these commands.

Note:

If more than one IM instrument is on-line when you set the ID, all IM instruments will be set to the same ID. The inductive modem receivers in IM instruments are very sensitive; two IM instruments that are side-by-side will take the same ID, even if one of them is not on the IM loop. **Therefore, separate IM instruments by at least 2 meters when setting IDs.**

ID?

Display MicroCAT ID (0-99).

***ID=ii**

Set MicroCAT ID to ii (ii= 0-99). Must be sent twice, because verification requested.
If more than one IM instrument is on-line, all IM instruments will be set to same ID.

MicroCAT Communication Microcontroller Status Commands

!iiGetHD

Get and display hardware data, which is fixed data describing MicroCAT:

Example: MicroCAT with ID=03 (user input in bold)

```
!03gethd
<HardwareData DeviceType = 'SBE37-IM MODEM'>
<Manufacturer>Sea-Bird Electronics, Inc.</Manufacturer>
<FirmwareVersion>2.0a</FirmwareVersion>
<FirmwareDate>26 February 2009 17:45</FirmwareDate>
<CommandSetVersion>1.0</CommandSetVersion>
</HardwareData>
```

!iiDS

Display communication microcontroller (modem) firmware version and firmware loader version for MicroCAT with ID=ii.

Example: MicroCAT with ID=03 (user input in bold).

```
!03ds
SBE37-IM Modem 2.0a
SBE 37-IM FirmwareLoader V 1.0
```

MicroCAT Acquisition Microcontroller Commands

Note:

If using the MicroCAT's internal RS-232 connector to set up and/or upload data from the MicroCAT: In SeatermV2's Instruments menu, select *SBE 37 RS232* instead of *SBE 37 IM*. This launches Seaterm232 instead of SeatermIM. Seaterm232 is similar to SeatermIM, but is optimized for RS-232 communications.

- When using inductive modem telemetry, all MicroCAT Acquisition Microcontroller commands are preceded by **#ii** (ii= MicroCAT ID), as shown in the command listings below.
- When using RS-232 telemetry (connecting directly to the MicroCAT's internal RS-232 serial connector), omit the **#ii** prefix shown in the command listings.

Status Command

Note:

#iiGetCD output does not include calibration coefficients. To display calibration coefficients, use the **#iiGetCC** command.

#iiGetCD

Get and display configuration data, which includes parameters related to MicroCAT setup. Most of these parameters can be user-input/modified. List below includes, where applicable, command used to modify parameter:

- Device type, Serial number
- Pressure sensor installed?
- Reference pressure to use in calculations if no pressure sensor installed (only appears if pressure sensor not installed)
[**#iiReferencePressure=**]
- Pump installed? Always no for 37-IM
- Output data format [**#iiOutputFormat=**]
- Output data in format compatible with 37-IMs with firmware < 3.0
[**CompatibleMode=**]?
- Output time with each sample?
Always yes for 37-IM.
- Output time with hex data if
#iiOutputFormat=0 [**#iiTxHexTime=**]?
- Output sample number when polled sampling command is sent
[**#iiTxSampleNum=**]?
- Interval between samples for autonomous sampling [**#iiSampleInterval=**]
- Baud rate when connecting directly to internal RS-232 connector
[**#iiBaudRate=**]

Example: MicroCAT with ID=03, with pressure sensor (user input in bold, command used to modify parameter in parentheses).

#03GETCD

```
<ConfigurationData DeviceType = 'SBE37-IM' SerialNumber = '03709999>
  <PressureInstalled>yes</PressureInstalled>           (inclusion of pressure sensor set at factory)
  <PumpInstalled>no</PumpInstalled>                   [only valid setting for 37-IM]
  <SampleDataFormat>raw Decimal</SampleDataFormat>    [#iiOutputFormat=]
  <CompatibleMode>no</CompatibleMode>                 [#iiCompatibleMode=]
  <OutputTime>yes</OutputTime>
  <TxHEXTime>no</TxHEXTime>                           [#iiTxHexTime=]
  <TxSampleNumber>yes</TxSampleNumber>               [#iiTxSampleNum=]
  <SampleInterval>15</SampleInterval>                 [#iiSampleInterval=]
  <PCBaudRate>9600</PCBaudRate>                       [#iiBaudRate=]
</ConfigurationData>
```

Status Commands (*continued*)**#iiGetSD**

Get and display status data, which contains data that changes while deployed.

List below includes, where applicable, command used to modify parameter:

- Device type, Serial number
- Date and time [**#iiDateTime=**] in ISO8601-2000 extended format (yyyy – mm-ddThh:mm:ss)
- Number of recorded events in event counter [reset with **#iiResetEC**]
- Voltages – main battery pack voltage and back-up lithium cell voltage
- Memory – [reset with **#iiInitLogging**]
 - Number of bytes in memory
 - Number of samples in memory
 - Number of additional samples that can be placed in memory
 - Length (number of bytes) of each sample
- Logging status –
 - yes or no (to indicate whether it is currently logging data);
 - if applicable, reason that logging has stopped

Example: MicroCAT with ID=03 (user input in bold, command used to modify parameter in parentheses)

#03getsd

```
<StatusData DeviceType = 'SBE37-IM' SerialNumber = '03709999'>
  <DateTime>2012-10-20T00:48:32</DateTime>
  <EventSummary numEvents = '0' />
  <Power>
    <vMain> 8.44</vMain>
    <vLith> 3.16</vLith>
  </Power>
  <MemorySummary>
    <Bytes>0</Bytes>
    <Samples>0</Samples>
    <SamplesFree>559240</SamplesFree>
    <SampleLength>15</SampleLength>
  </MemorySummary>
  <AutonomousSampling>no, stop command</AutonomousSampling>
</StatusData>
```

[**#iiDateTime=**]
[can clear with **#iiResetEC=**]

[can clear with **#iiInitLogging**]
[can clear with **#iiInitLogging**]

[**#iiStartNow** or **#iiStartLater**, **#iiStop**]

Status Commands (*continued*)**Note:**

Dates shown are when calibrations were performed.

#iiGetCC

Get and display calibration coefficients, which are initially factory-set and should agree with Calibration Certificates shipped with MicroCAT.

Example: MicroCAT with ID=03, with a pressure sensor (user input in bold, command used to modify parameter in parentheses)

#03getcc

```

<CalibrationCoefficients DeviceType = 'SBE37-IM' SerialNumber = '03709999'>
  <Calibration format = 'TEMP1' id = 'Temperature'>
    <SerialNum>03709999</SerialNum>
    <CalDate>04-Aug-12</CalDate>                                [##iTCalDate=]
    <A0>6.947802e-05</A0>                                       [##iTA0=]
    <A1>2.615233e-04</A1>                                       [##iTA1=]
    <A2>-1.265233e-06</A2>                                       [##iTA2=]
    <A3>1.310479e-07</A3>                                       [##iTA3=]
  </Calibration>
  <Calibration format = 'WBCONDO' id = 'Conductivity'>
    <SerialNum>03709999</SerialNum>
    <CalDate>04-Aug-12</CalDate>                                [##iCCalDate=]
    <G>-1.009121e+00</G>                                       [##iCG=]
    <H>1.410162e-01</H>                                       [##iCH=]
    <I>-2.093167e-04</I>                                       [##iCI=]
    <J>3.637053e-05</J>                                       [##iCJ=]
    <PCOR>-9.570000e-08</PCOR>                                       [##iCTCor=]
    <TCOR>3.250000e-06</TCOR>                                       [##iCPCor=]
    <WBOTC>1.954800e-05</WBOTC>                                       [##iCWBOTC=]
  </Calibration>
  <Calibration format = 'STRAIN0' id = 'Pressure'>
    <SerialNum>2478619</SerialNum>
    <CalDate>28-Jul-12</CalDate>                                [##iPCalDate=]
    <PA0>1.729067e+00</PA0>                                       [##iPA0=]
    <PA1>1.415754e-01</PA1>                                       [##iPA1=]
    <PA2>1.246912e-08</PA2>                                       [##iPA2=]
    <PTCA0>2.243971e+00</PTCA0>                                       [##iPTCA0=]
    <PTCA1>1.055267e+00</PTCA1>                                       [##iPTCA1=]
    <PTCA2>-2.276308e-02</PTCA2>                                       [##iPTCA2=]
    <PTCB0>1.003849e+02</PTCB0>                                       [##iPTCB0=]
    <PTCB1>1.014510e-02</PTCB1>                                       [##iPTCB1=]
    <PTCB2>-2.057110e-04</PTCB2>                                       [##iPTCB2=]
    <PTEMPA0>5.669780e+01</PTEMPA0>                                       [##iPTempA0=]
    <PTEMPA1>-5.474043e-02</PTEMPA1>                                       [##iPTempA1=]
    <PTEMPA2>1.267908e-05</PTEMPA2>                                       [##iPTempA2=]
    <POFFSET>0.000000e+00</POFFSET>                                       [##iPOffset= (decibars)]
    <PRANGE>0.000000e+00</PRANGE>                                       [##iPRange= (psi)]
  </Calibration>
</CalibrationCoefficients>

```

Status Commands (*continued*)**#iiGetEC**

Get and display event counter data, which can help to identify root cause of a malfunction. Event counter records number of occurrences of common timeouts, power-on resets, etc. Can be cleared with **#iiResetEC**. Possible events that may be logged include:

- WDT reset – unexpected reset
- PON reset - power cycled on (each time power is applied)
- ErrorADC12TimeOut – response delayed from A/D converter that measures main power and back-up lithium cell power
- ErrorUART0TimeOut – timeout for transmitter to finish transmitting previous character
- ErrorAD7714TimeOut – response delayed from temperature and pressure A/D converter
- ErrorInvWakeUpFlag – unexpected wakeup
- ErrorFLASHTimeOut – problem with writing data to FLASH memory
- Alarm long - time to take next sample is too far in future
- Alarm short - woke up MicroCAT to send a command while logging, and missed taking a sample
- LoggingRestartNoAlarm – no sample taken for 8 hours while logging, restart logging
- LoggingRestartPON – power cycled while logging, logging restarted
- ImWatchDogTimeOut – communication microcontroller watch dog timer timed out

Example: MicroCAT with ID=03 (user input in bold, command used to modify parameter in parentheses)

#03getec

```
<EventCounters DeviceType = 'SBE37-IM' SerialNumber = '03709999'>
  <EventSummary numEvents = '0' />
</EventCounters>
```

[can clear with **#iiResetEC**]

#iiResetEC

Delete all events in event counter (number of events displays in **#iiGetSD** response, and event details display in **#iiGetEC** response).

Status Commands (*continued*)**#iiGetHD**

Get and display hardware data, which is fixed data describing MicroCAT:

- Device type, Serial number
- Manufacturer
- Firmware version
- Firmware date
- Command set version
- PCB assembly numbers
- Manufacture date
- Firmware loader version
- Sensor types and serial numbers

Example: MicroCAT with ID=03 (user input in bold, command used to modify parameter in parentheses)

#03gethd

```
<HardwareData DeviceType = 'SBE37-IM' SerialNumber = '03709999'>
  <Manufacturer>Sea-Bird Electronics, Inc.</Manufacturer>
  <FirmwareVersion>3.0e</FirmwareVersion>
  <FirmwareDate>10 August 2012 10:40</FirmwareDate>
  <CommandSetVersion>1.1</CommandSetVersion>
  <PCBAssembly>41609A</PCBAssembly>
  <PCBAssembly>41610A</PCBAssembly>
  <PCBAssembly>41611B</PCBAssembly>
  <MfgDate>17 Aug 2010</MfgDate>
  <FirmwareLoader>SBE 37 FirmwareLoader V 1.0</FirmwareLoader>
  <InternalSensors>
    <Sensor id = 'Temperature'>
      <type>temperature-1</type>
      <SerialNumber>03709999</SerialNumber>
    </Sensor>
    <Sensor id = 'Conductivity'>
      <type>conductivity-1</type>
      <SerialNumber>03709999</SerialNumber>
    </Sensor>
    <Sensor id = 'Pressure'>
      <type>strain-0</type>
      <SerialNumber>2478619</SerialNumber>
    </Sensor>
  </InternalSensors>
</HardwareData>
```

Status Commands (*continued*)**#iiDS**

Display operating status and setup parameters.

List below includes, where applicable, command used to modify parameter:

- Firmware version, serial number, date and time [**#iiDateTime=** or equivalent global command]
- Main battery pack voltage and back-up lithium cell voltage
- Number of samples in memory [**#iiSampleNumber=**] and available sample space in memory
- Logging status
- Sample interval time [**#iiSampleInterval=**]
- Output data format [**#iiOutputFormat=**]
- Output data in format compatible with 37-IMs with firmware < 3.0 [**CompatibleMode=**]?
- Output sample number when polled sampling command is sent [**#iiTxSampleNum=**]?
- Output time with hex data if **#iiOutputFormat=0** [**#iiTxHexTime=**]?
- Pump installed? Always no for 37-IM.
- Reference pressure [**#iiReferencePressure=**]; only displays if no pressure sensor installed
- Baud rate when connecting directly to internal RS-232 connector [**#iiBaudRate=**]

Logging status can be:

- logging not started
- logging data
- not logging: waiting to start at...
- not logging: received stop command
- not logging: low battery
- unknown status

Note:

The 37-IM and 37-IMP use the same firmware. The internal pump is applicable to the 37-IMP MicroCAT only.

Example: Display status for MicroCAT 03 (user input in bold, command used to modify parameter in parentheses).

#03DS

```

SBE37-IM V 3.0e SERIAL NO. 1000 20 Oct 2012 11:55:19           [#iiDateTime=]
vMain = 8.08, vLith = 3.08
samplenumber = 0, free = 559240                                [#iiSampleNumber=]
not logging data
sample interval = 30 seconds                                   [#iiSampleInterval=]
data format = HEX converted engineering                       [#iiOutputFormat=]
compatible mode disabled                                     [#iiCompatibleMode=]
transmit sample number                                       [#iiTxSampleNum=]
transmit sample HEX time                                     [#iiTxHexTime=]
pump installed = no [only valid setting for 37-IM]
reference pressure = 10.0 decibars                            [#iiReferencePressure=]
PC baud rate = 9600                                          [#iiBaudRate=]

```

Status Commands (*continued*)**Notes:**

- The **#iiDC** and **#iiGetCC** responses contain the same information, but in different formats.
- Dates shown are when calibrations were performed.

#iiDC

Display calibration coefficients, which are initially factory-set and should agree with Calibration Certificates shipped with MicroCAT.

Example: MicroCAT with a pressure sensor, with ID=03 (user input in bold).

#03DC

SBE37-IM V 3.0e 9999

temperature: 04-aug-12

TA0 = 6.947802e-05

TA1 = 2.615233e-04

TA2 = -1.265233e-06

TA3 = 1.310479e-07

conductivity: 04-aug-12

G = -1.036689e+00

H = 1.444342e-01

I = -3.112137e-04

J = 3.005941e-05

CPCOR = -9.570001e-08

CTCOR = 3.250000e-06

WBOTC = 1.968100e-05

pressure S/N 2478619, range = 2901 psia, 03-aug-12

PA0 = 0.000000e+00

PA1 = 0.000000e+00

PA2 = 0.000000e+00

PTCA0 = 0.000000e+00

PTCA1 = 0.000000e+00

PTCA2 = 0.000000e+00

PTCB0 = 0.000000e+00

PTCB1 = 0.000000e+00

PTCB2 = 0.000000e+00

PTEMPA0 = 0.000000e+00

PTEMPA1 = 0.000000e+00

PTEMPA2 = 0.000000e+00

POFFSET = 0.000000e+00

[#iiTCalDate=]

[#iiTA0=]

[#iiTA1=]

[#iiTA2=]

[#iiTA3=]

[#iiCCalDate=]

[#iiCG=]

[#iiCH=]

[#iiCI=]

[#iiCJ=]

[#iiCPCor=]

[#iiCTCor=]

[#iiCWBOTC=]

[#iiPRange= (psi), #iiPCalDate=]

[#iiPA0=]

[#iiPA1=]

[#iiPA2=]

[#iiPTCA0=]

[#iiPTCA1=]

[#iiPTCA2=]

[#iiPTCB0=]

[#iiPTCB1=]

[#iiPTCB2=]

[#iiPTempA0=]

[#iiPTempA1=]

[#iiPTempA2=]

[#iiPOffset= (decibars)]

General Setup Commands

#iiDateTime=
mmddyymmss Set real-time clock month, day, year, hour, minute, second.

Example: Set current date and time for MicroCAT with ID=03 to 10 January 2012 12:00:00 (user input in bold).

#03DATETIME=01102012120000

Note:

See *Upload Using RS-232 (Serial Mode) Telemetry* in Section 4: *Deploying and Operating MicroCAT* for details on connecting directly to the MicroCAT's internal RS-232 connector. This is particularly useful for uploading data from memory, as the inductive modem communication (between MicroCAT and SIM or between MicroCAT and IMM) is at 1200 baud.

#iiBaudRate=x x= baud rate (600, 1200, 2400, 4800, 9600, 19200, 38400, 57600, or 115200) **for connecting in Serial Mode (communicating through MicroCAT's internal RS-232 connector). This command must be sent while communicating with inductive modem telemetry; it cannot be sent while communicating via RS-232.** Check capability of your computer and terminal program before increasing baud; high baud requires a short cable and good PC serial port with accurate clock.

#iiOutputExecutedTag=x x=Y: Display XML Executing and Executed tags. Executed tag displays at end of each command response; Executing tag displays one or more times if MicroCAT response to command requires additional time.
 x=N: Do not.

Example: Set MicroCAT with ID=03 to output Executed and Executing tags (user input in bold).

#03outputexecutedtag=y
 <Executed/>
#03getcd
 . . . (#03GetCD response)
 <Executed/>

#iiReferencePressure=x x = reference pressure (gauge) in decibars. MicroCAT without installed pressure sensor uses this reference pressure in conductivity calculation. Entry ignored if MicroCAT includes pressure sensor.

QS

For use only in Serial mode (communicating through internal RS-232 serial connector). Place MicroCAT in quiescent (sleep) state. Main power is turned off. Data logging and memory retention are not affected.

Note:

If the FLASH memory is filled to capacity, autonomous sampling stops (i.e., the MicroCAT does not overwrite the data in memory).

Note:

Do not send #iiInitLogging or #iiSampleNumber=0 until all data has been uploaded. These commands do not delete the data; they just reset the data pointer. **If you accidentally send one of these commands before uploading,** recover the data as follows:

1. Set **#iiSampleNumber=x**, where **x** is your estimate of number of samples in memory.
2. Upload data. If **x** is more than actual number of samples in memory, data for non-existent samples will be bad, random data. Review uploaded data file carefully and delete any bad data.
3. If desired, increase **x** and upload data again, to see if there is additional valid data in memory.

Note:

See *Data Format* after these *Command Descriptions*.

Note:

#iiTxSampleNum=Y could be used to verify that logging is occurring at the correct rate. For example, while logging:

1. Send **#iiSL**.
2. After some interval, send **#iiSL** again. Compare change in output sample numbers to expected change based on **#iiSampleInterval**.

Memory Setup Commands

#iiInitLogging

Initialize logging – after all previous data has been uploaded, initialize logging before starting to sample again to make entire memory available for recording. **#iiInitLogging** sets sample number (**#iiSampleNumber=**) to 0 (sampling will start with sample 1). **Command must be sent twice to initialize logging.** If not initialized, data will be stored after last recorded sample. **Do not send #iiInitLogging until all existing data has been uploaded.**

#iiSampleNumber=x

x= sample number for last sample in memory. **Command must be sent twice to set sample number.** **#iiSampleNumber=0** is equivalent to **#iiInitLogging**. **Do not send #iiSampleNumber=0 until all existing data has been uploaded.**

Output Format Setup Commands

#iiOutputFormat=x

x=0: output converted hex data.

x=1 (default): output converted decimal data.

x=2: output converted decimal data, alternate format.

x=3: output raw decimal data.

x=4: output converted decimal data in XML.

#iiCompatibleMode=x

x=Y: Output data in format compatible with 37-IM/IMP with firmware < 3.0 –

- If **#iiOutputFormat=2** or **#iiFormat=2**, output date as mm-dd-yyyy instead of dd-mm-yyyy.
- Omit start sample number and start sample time lines from **#iiDNx** output.

x=N: Do not output data in compatible mode.

#iiTxHexTime=x

x=Y: If **#iiOutputFormat=0**, output date and time with hex data.

x=N: If **#iiOutputFormat=0**, do not output date and time with hex data.

#iiTxSampleNum=x

x=Y: Output 6-character sample number (number of samples in memory at time sample was taken) with data from **Dataii**, **!iiData**, **#iiTS**, **#iiTSS**, **#iiTSN:x**, **#iiSL**, **#iiSLT**, **#iiSACG**, or **#iiSAC**.

x=N: Do not output sample number.

Autonomous Sampling (Logging) Commands

Logging commands direct the MicroCAT to sample data at pre-programmed intervals and store the data in its FLASH memory.

Notes:

- In SeatermIM, to save data to a file (if transmitting occasional samples while logging), click the Capture menu before beginning logging.
- If the MicroCAT is logging and the battery pack voltage is less than 6.15 volts for ten consecutive scans, the MicroCAT halts logging and sets the logging status to low battery.
- If the FLASH memory is filled to capacity, sampling continues, but excess data is not saved in memory (i.e., the MicroCAT does not overwrite the data in memory).

#iiSampleInterval=x

x= interval (6 – 21,600 seconds) between samples. When commanded to start sampling (with **#iiStartNow**, **#iiStartLater**, **#iiGA**, **GData**, or **ResumeLogging**), MicroCAT takes a sample, stores data in FLASH memory, and powers down at **x** second intervals.

#iiStartNow

Start logging now, at rate defined by **#iiSampleInterval**. First sample will be taken after delay of **#iiSampleInterval**. Data is stored in FLASH memory.

#iiStartDateTime=mmddyyyymmss

Set delayed logging start month, day, year, hour, minute, second.

Notes:

- After receiving **#iiStartLater**, the MicroCAT displays `not logging: waiting to start` in reply to **#iiDS**. Once logging starts, the reply shows `logging`.
- If the delayed start time has already passed when **#iiStartLater** is received, the MicroCAT executes **#iiStartNow**.
- If the delayed start date and time is more than 30 days in the future when **#iiStartLater** is received, the MicroCAT assumes that the user made an error in setting the delayed start date and time, and it executes **#iiStartNow**.

#iiStartLater

Start logging at time set with delayed start date and time commands, at rate defined by **#iiSampleInterval**. Data is stored in FLASH memory. If you need to change MicroCAT setup after **#iiStartLater** has been sent (but before logging has started), send **#iiStop**, change setup as desired, and then send **#iiStartLater** again.

Example: Program MicroCAT 03 to start logging on 20 July 2012 12:00:00 (user input in bold).

```
#03STARTDATETIME=07202012120000
#03STARTLATER
```

Note:

You may need to send **#iiStop** several times to get the MicroCAT to respond. This is most likely to occur if sampling with a small **#iiSampleInterval**.

#iiStop

Stop logging or stop waiting to start logging (if **#iiStartLater** was sent but logging has not begun). Connect to MicroCAT (*Connect* in SeatermIM's Communications menu) before sending **#iiStop**. **#iiStop** must be sent before uploading data.

Autonomous Sampling (Logging) Commands *(continued)*

Notes:

- Logging commands related to averaging are typically used only for customized acquisition. **GData** and **Dataii** more easily start averaging and get averaged data (see *MicroCAT Communication Microcontroller Commands*).
- Averaged data obtained with **#iiSACG**, **#iiSARG**, **#iiSAC**, or **#iiSAR** is not stored in FLASH memory.
- The setting for **#iiCompatibleMode=** affects the date format for output if **#iiOutputFormat=2** or **#iiFormat=2**.

#iiGA	Start logging now. First sample will be taken after delay of (#iiSampleInterval/2). Data is stored in FLASH memory.
#iiSACG	Output averaged data, in format specified by #iiOutputFormat= . Number of samples in average is appended to end of data string. Next sample will be taken after delay of (#iiSampleInterval/2). Start new average.
#iiSARG	Output averaged data, in raw decimal format. Number of samples in average is appended to end of data string. Next sample will be taken after delay of (#iiSampleInterval/2). Start new average.
#iiSAC	Output averaged data, in format specified by #iiOutputFormat= . Number of samples in average is appended to end of data string. Continue averaging.
#iiSAR	Output averaged data, in raw decimal format. Number of samples in average is appended to end of data string. Continue averaging.
#iiSS	Output statistics (raw decimal format): number of samples in average, averaged data maximum, averaged data minimum, range of averaged data, averaged data. Continue averaging.

Polled Sampling Commands

Notes:

- The MicroCAT has a buffer that stores the most recent data sample, regardless of whether it was obtained with autonomous sampling or polled sampling. Unlike data in the FLASH memory, data in the buffer is erased upon removal or failure of power.
- The setting for **#iiCompatibleMode=** affects the date format for output if **#iiOutputFormat=2** or **#iiFormat=2**.

	These commands are used to request a sample from the MicroCAT. Data from these commands is not stored in FLASH memory, except where noted.
#iiTS	Take sample, store data in buffer, and output data in format specified by #iiOutputFormat= .
#iiTSR	Take sample, store data in buffer, and output data in raw decimal format (regardless of #iiOutputFormat=).
#iiTSH	Take sample and store data in buffer (do not output data).

Polled Sampling Commands *(continued)*

#iiTSS	Take sample, store data in buffer and in FLASH memory , and output data in format specified by #iiOutputFormat= . Note: MicroCAT ignores command if sampling data (#iiStartNow , #iiStartLater , #iiGA , GData , or ResumeLogging has been sent).
#iiTSN:x	Take x samples and output data. Note: MicroCAT ignores command if sampling data (#iiStartNow , #iiStartLater , #iiGA , GData , or ResumeLogging has been sent).
#iiSL	Output data from last sample, in format specified by #iiOutputFormat= .
#iiSLT	Output data from last sample, in format specified by #iiOutputFormat= . Then take new sample, and store data in buffer (do not output data from new sample).
#iiSLTR	Output data from last sample, in raw decimal format. Then take new sample, and store data in buffer (do not output data from new sample).
#iiDNx	Upload last x scans from FLASH memory, in format specified by #iiOutputFormat= . Most often used to retrieve data periodically from MicroCAT while it is on mooring. Maximum of 250 samples can be uploaded at one time with #iiDNx . You do not need to stop logging (#iiStop) before sending #iiDNx. As data is uploaded, screen first displays start time =, start sample number =. These are start time and starting sample number for uploaded data.

Note:If **#iiCompatibleMode=Y**:

In response to **#iiDNx**, the 37-IM does **not** output the start time and start sample number. Additionally, if **#iiOutputFormat=2** or **#iiFormat=2**, the date format is modified. These features provide compatibility with systems programmed for 37-IM/IMPs with digital firmware < 3.0.

Example: For a system with MicroCATs 01, 02, and 03 which is sampling every 10 minutes (144 times/day), upload latest data once per day (user input in bold):

(Click Capture menu and enter desired filename in dialog box.)

```

#01DN144      (upload last 144 samples from MicroCAT 01)
STAYON       (reset time-out timer on all MicroCATs so 02 and 03 do not go to sleep while uploading data from 01)
#02DN144      (upload last 144 samples from MicroCAT 02)
STAYON       (reset time-out timer on all MicroCATs so 01 and 03 do not go to sleep while uploading data from 02)
#03DN144      (upload last 144 samples from MicroCAT 03)
STAYON       (reset time-out timer on all MicroCATs so 01 and 02 do not go to sleep while uploading data from 03)
PWROFF       (send command to all MicroCATs to go to sleep; logging not affected)

```

Data Upload Commands

Send **#iiStop** to stop logging before uploading data.

Upload data using one of these telemetry methods:

- **RS-232 (serial mode)** - Much faster upload (up to 115,200 baud) is available in serial mode; however, you must remove the battery end cap to access the internal RS-232 serial connector. The RS-232 telemetry allows ASCII or binary upload; binary upload is inherently twice as fast as ASCII upload. When using RS-232 telemetry, select *SBE 37 RS232* in SeatermV2's Instrument menu; this launches **Seaterm232**.
- **Inductive modem** – Data can be uploaded while the MicroCAT is deployed, or is wired in the lab as shown in *Test Setup with SIM* or *Test Setup with IMM* in *Section 3: Preparing MicroCAT for Deployment*. Upload speed is limited by the baud rate between the MicroCAT and IMM/SIM, which is 1200 baud. We recommend uploading with IM telemetry only if you are interested in looking at a small amount of data or need to upload the data without recovering the instrument.

#iiGetSamples:b,e

Upload data from scan **b** to scan **e**, in format defined by **#iiOutputFormat=**. First sample is number 1. Maximum of 250 samples can be uploaded at one time (When Upload menu is used, samples numbering more than 250 are automatically received.) As data is uploaded, screen first displays
start time =
start sample number =
These are start time and starting sample number for last set of logged data; can be useful in determining what data to review.

Example: Upload samples 1 to 200 for MicroCAT with ID=03 (user input in bold).

```
#03STOP          (stop logging for MicroCAT 03)
(Click Capture menu and enter desired filename in dialog box)
#03GETSAMPLES : 1 , 200
```

Notes:

- The uploaded data format is the same, regardless of the choice of upload telemetry (IM or RS-232) and type (ASCII or binary).
- **Use SeatermIM's or Seaterm232's Upload menu to upload data that will be processed by SBE Data Processing.** Manually entering a data upload command does not produce data with the required header information and required format for processing by our software. When using the Upload menu, the 250 sample upload limitation described for **#iiDDb,e** and **#iiGetSamples:b,e** does not apply. These commands are included here for reference for users who are writing their own software.
- **If not using the Upload menu** - To save data to a file, click the Capture menu before entering a data upload command.
- The setting for **#iiCompatibleMode=** affects the date format for **#iiGetSamples:b,e** if **#iiOutputFormat=2** or **#iiFormat=2**.
- See *Data Format* after these *Command Descriptions*.

#iiDDb,e

Upload data from scan **b** to **e**, in alternate converted decimal form (**#iiOutputFormat=2**) (regardless of user setup for **#iiOutputFormat=**). First sample is number 1. Maximum of 250 samples can be uploaded at one time (When Upload menu is used, samples numbering more than 250 are automatically received.) As data is uploaded, screen first displays
start time =,
start sample number =.
These are start time and starting sample number for last set of logged data; can be useful in determining what data to review.

Note:

The setting for **#iiCompatibleMode=** affects the date format for **#iiDDb,e**. See *Data Format* after these *Command Descriptions*.

Example: Upload samples 1 through 200 for MicroCAT 03 (user input in bold):

```
#03STOP          (stop logging for MicroCAT 03)
(Click Capture menu and enter desired filename in dialog box.)
#03DD1 , 200    (upload samples 1 through 200 from MicroCAT 03)
```

Note:

F = floating point number
S = string with no spaces

Calibration Coefficients Commands

The individual Coefficient Commands listed below are used to modify a particular coefficient or date:

Temperature

#iiTCalDate=S	S=Temperature calibration date
#iiTA0=F	F=Temperature A0
#iiTA1=F	F=Temperature A1
#iiTA2=F	F=Temperature A2
#iiTA3=F	F=Temperature A3

Conductivity

#iiCalDate=S	S=Conductivity calibration date
#iiCG=F	F=Conductivity G
#iiCH=F	F=Conductivity H
#iiCI=F	F=Conductivity I
#iiCJ=F	F=Conductivity J
#iiWBOTC=F	F=Conductivity wbotc
#iiCTCor=F	F=Conductivity ctcor
#iiCPCor=F	F=Conductivity cpcor

Pressure

#iiPCalDate=S	S=Pressure calibration date
#iiPA0=F	F=Pressure A0
#iiPA1=F	F=Pressure A1
#iiPA2=F	F=Pressure A2
#iiPTCA0=F	F=Pressure ptca0
#iiPTCA1=F	F=Pressure ptca1
#iiPTCA2=F	F=Pressure ptca2
#iiPTCB0=F	F=Pressure ptcb0
#iiPTCB1=F	F=Pressure ptcb1
#iiPTCB2=F	F=Pressure ptcb2
#iiPTempA0=F	F=Pressure temperature a0
#iiPTempA1=F	F=Pressure temperature a1
#iiPTempA2=F	F=Pressure temperature a2
#iiPOffset=F	F=Pressure offset (decibars)

Data Format

Notes:

- Time is the time at the **start** of the sample.
- The MicroCAT's pressure sensor is an absolute sensor, so its **raw** output includes the effect of atmospheric pressure (14.7 psi). As shown on the Calibration Sheet, Sea-Bird's calibration (and resulting calibration coefficients) is in terms of psia. However, when outputting pressure in **decibars**, the MicroCAT outputs pressure relative to the ocean surface (i.e., at the surface the output pressure is 0 decibars). The MicroCAT uses the following equation to convert psia to decibars:

$$\text{pressure (db)} = [\text{pressure (psia)} - 14.7] * 0.689476$$

Each scan ends with a carriage return <CR> and line feed <LF>.

- **#iiOutputFormat=0**: converted hex data, intended for fast upload and/or diagnostic use at Sea-Bird

ttttccccppppTTTTTTTT

where

- tttt = temperature number in hex
- ccccc = conductivity number in hex
- pppp = pressure number in hex, with bytes in reverse order (output if MicroCAT includes pressure sensor)
- TTTTTTTT = time number in hex, with bytes in reverse order (output if **#iiTxHexTime=Y**)

Conversion of the hex data to temperature, conductivity, pressure, and time in engineering units is described below:

$$\text{temperature (}^\circ\text{C, ITS-90)} = (\text{temperature number} / 10000) - 10$$

$$\text{conductivity (S/m)} = (\text{conductivity number} / 100000) - 0.5$$

$$\text{pressure (db)} = [\text{pressure number} * \text{pressure range} / (0.85 * 65536)] - (0.05 * \text{pressure range})$$

where

Pressure range is in decibars. The file header shows the pressure range in psia in the **GetCC** or **DC** (calibration coefficients) command response.

Convert the pressure range from psia to decibars using the following equation:

$$\text{Pressure (db)} = 0.6894757 * [\text{Pressure (psia)} - 14.7]$$

$$\text{Date and time} = \text{date and time number (seconds since January 1, 2000)}.$$

Example: Hex Scan = 531850c355e50a805F0C14

$$\text{tttt} = 53185 \text{ hex} = 340357 \text{ decimal} \quad \text{temperature (}^\circ\text{C)} = (\text{tttt} / 10000) - 10 = (340357 / 10000) - 10 = 24.0357 \text{ }^\circ\text{C}$$

$$\text{cccc} = 0c355 \text{ hex} = 50005 \text{ decimal} \quad \text{conductivity (S/m)} = (\text{cccc} / 100000) - 0.5 = (50005 / 100000) - 0.5 = 0.00005 \text{ S/m}$$

$$\text{pppp} = e50a \text{ in hex (bytes in reverse order)} = 0ae5 \text{ in hex} = 2789 \text{ decimal}$$

From **DC** response in file header, the pressure range is 1000 psia.

$$\text{Pressure range (db)} = 0.6894757 * [\text{Pressure (psia)} - 14.7] = 679.34040721$$

$$\text{Pressure (db)} = [\text{pressure number} * \text{pressure range} / (0.85 * 65536)] - (0.05 * \text{pressure range}) \\ = [2789 * 679.34040721 / (0.85 * 65536)] - (0.05 * 679.34040721) = 0.045 \text{ db}$$

$$\text{TTTTTTTT} = 805F0C14 \text{ hex (bytes in reverse order)} = 140C5F80 = 336355200 \text{ decimal}$$

$$\text{Date and time} = 336355200 \text{ seconds since January 1, 2000.}$$

$$336355200 / (3600 \text{ sec/hr} * 24 \text{ hrs/day}) = 3893 \text{ days since January 1, 2000 (convert to date and time)}$$

- **#iiOutputFormat=1** (default): converted decimal data

ii, nnnnn,tttt.tttt,ccc.cccccc,ppppp.ppp, dd mmm yyyy, hh:mm:ss, sample, navg

where

- ii = MicroCAT ID (0 – 99); sent only in response to **Dataii** or **!iiData**.
- nnnnn = MicroCAT serial number (5 digits, omits the 037 prefix); sent only in response to **Dataii**, **!iiData**, **#iiSACG**, **#iiSAC**, or polled sampling command (but not sent for **#iiDNx**).
- tttt.tttt = temperature (°C, ITS-90).
- ccc.cccccc = conductivity (S/m).
- ppppp.ppp = pressure (decibars); sent only if pressure sensor installed.
- dd mmm yyyy = day, month, year.
- hh:mm:ss = hour, minute, second.
- sample = sample number (number of samples in FLASH memory at the time the command to take a sample was sent); sent only if **#iiTxSampleNum=Y** and in response to **Dataii**, **!iiData**, **#iiSACG**, **#iiSAC**, or a polled sampling command (but not sent for **#iiDNx**).
- navg = number of data samples contained in average; sent only in response to **Dataii**, **!iiData**, **#iiSACG**, **#iiSARG**, **#iiSAC**, or **#iiSAR**.

Leading zeros are suppressed, except for one zero to the left of the decimal point. All data is separated with a comma.

Example: Response to **Dataii** for MicroCAT with **#iiOutputFormat=1**, ID=03, pressure sensor installed, **#iiTxSampleNum=Y**:
 03,09999, 8.5796, 0.15269, 531.316, 26 Nov 2012, 09:01:44, 1126, 250
 (ID, serial number, temperature, conductivity (S/m), pressure, date, time, sample number, number of samples in average)

- **#iiOutputFormat=2**: converted decimal data, *alternate*

Notes:

- **#iiOutputFormat=2** provides **conductivity** output in **mS/cm** instead of S/m.
- When **#iiCompatibleMode=Y** and **#iiOutputFormat=2**, the data is identical to the format from an SBE 37-IM/IMP with **digital firmware < 3.0** and **#iiFormat=2**. It is provided for compatibility with systems programmed for those older instruments.

When #iiCompatibleMode=N

ii,nnnnn,ccc.cccc,ttt.tttt,pppp.ppp,hh:mm:ss,dd-mm-yyyy,sample,navg

When #iiCompatibleMode=Y

ii,nnnnn,ccc.cccc,ttt.tttt,pppp.ppp,hh:mm:ss,mm-dd-yyyy,sample,navg

where

- ii = MicroCAT ID (0 – 99); sent only in response to **Dataii** or **!iiData**.
- nnnnn = MicroCAT serial number (5 digits, omits the 037 prefix); sent only in response to **Dataii**, **!iiData**, **#iiSACG**, **#iiSAC**, or polled sampling command (but not sent for **#iiDNx**).
- ccc.cccc = conductivity (**mS/cm**).
- ttt.tttt = temperature (°C, ITS-90).
- pppp.ppp = pressure (decibars); sent only if pressure sensor installed.
- hh:mm:ss = hour, minute, second.
- dd-mm-yyyy = day, month, year (date output if **#iiCompatibleMode=N**).
- mm-dd-yyyy = month, day, year (date output if **#iiCompatibleMode=Y**).
- sample = sample number (number of samples in FLASH memory at the time the command to take a sample was sent); sent only if **#iiTxSampleNum=Y** and in response to **Dataii**, **!iiData**, **#iiSACG**, **#iiSAC**, or a polled sampling command (but not sent for **#iiDNx**).
- navg = number of data samples contained in average; sent only in response to **Dataii**, **!iiData**, **#iiSACG**, **#iiSARG**, **#iiSAC**, or **#iiSAR**.

Leading zeros are suppressed, except for one zero to the left of the decimal point. All data is separated with a comma.

Example: Response to **Dataii** for MicroCAT with **#iiOutputFormat=2**, ID=03, pressure sensor installed, **#iiTxSampleNum=Y**:

Case 1: **#iiCompatibleMode=N**

03,09999, 1.5269, 8.5796, 531.316, 09:01:44, 26-11-2012, 1126, 250

(ID, serial number, conductivity (mS/cm), temperature, pressure, time, date (**dd-mm-yyyy**), sample number, samples in average)

Case 2: **#iiCompatibleMode=Y**

03,09999, 1.5269, 8.5796, 531.316, 09:01:44, 11-26-2012, 1126, 250

(ID, serial number, conductivity (mS/cm), temperature, pressure, time, date (**mm-dd-yyyy**), sample number, samples in average)

- **#iiOutputFormat=3**: raw decimal data, intended for diagnostic use at Sea-Bird

ii,ttttt,cccc.ccc,pppppp,vvvv,dd mmm yyyy, hh:mm:ss,navg

where

- ii = MicroCAT ID (0 – 99); sent only in response to **Dataii** or **!iiData**.
- tttttt = temperature A/D counts.
- cccc.ccc = conductivity frequency (Hz).
- pppppp = pressure sensor pressure A/D counts; sent only if pressure sensor installed.
- vvvv = pressure sensor pressure temperature compensation A/D counts; sent only if pressure sensor installed.
- dd mmm yyyy = day, month, year.
- hh:mm:ss = hour, minute, second.
- avg = number of data samples contained in average; sent only in response to **Dataii**, **!iiData**, **#iiSACG**, or **#iiSAC**.

All data is separated with a comma and a space.

Note:

Sample number is never transmitted if **#iiOutputFormat=3**, regardless of the setting for **#iiTxSampleNum=**.

Example: Response to **Dataii** for MicroCAT with **#iiOutputFormat=3**, ID=03, pressure sensor installed:

03,524276, 2886.656, 785053, 2706, 26 Nov 2012, 09:01:34, 250
(ID, temperature counts, conductivity frequency, pressure sensor pressure counts, pressure sensor temperature compensation counts, date, time, number of samples in average)

- **#iiOutputFormat=4**: converted decimal data in XML

Note:

For ease in reading, the data structure is shown with each XML tag on a separate line. However, there are no carriage returns or line feeds between tags (see example below).

```
ii,
<?xml version="1.0"?>
<datapacket>
<hdr>
<mfg>Sea-Bird</mfg>
<model>37IM</model>
<sn>nnnnnnnn</sn>
</hdr>
<data>
<t1>ttt.tttt</t1>
<c1>cc.ccccc</c1>
<p1>pppp.ppp </p1>
<smp1>sample</smp1>
<navg>navg</navg>
<dt>yyyy-mm-ddThh:mm:ss</dt>
</data>
</datapacket>
```

where

- ii = MicroCAT ID (0 – 99); sent only in response to **Dataii** or **!iiData**.
- nnnnnnnn = MicroCAT serial number.
- ttt.tttt = temperature (°C, ITS-90).
- cc.ccccc = conductivity (S/m).
- pppp.ppp = pressure (decibars); sent only if pressure sensor installed.
- sample = sample number (number of samples in FLASH memory at the time the command to take a sample was sent); sent only if **#iiTxSampleNum=Y** and in response to a polled sampling command (but not sent for **#iiDNx**)
- navg = number of data samples contained in average; sent only in response to **Dataii**, **!iiData**, **#iiSACG**, or **#iiSAC**.
- yyyy-mm-ddThh:mm:ss = year, month, day, hour, minute, second.

Leading zeros are suppressed, except for one zero to the left of the decimal point.

Example: Response to **Dataii** for MicroCAT with **#iiOutputFormat=4**, ID=03, pressure sensor installed, **#iiTxSampleNum=Y**:
03,<?xml version="1.0"?><datapacket><hdr><mfg>Sea-Bird</mfg><model>37IM</model>
<sn>03709999</sn></hdr><data><t1> 8.5796</t1><c1> 0.15269</c1><p1> 531.316</p1>
<smp1>1126</smp1><navg>250</navg><dt>2012-11-26T09:01:44</dt></data></datapacket> CRLF
(ID, manufacturer, SBE model, serial number, temperature, conductivity (S/m), pressure, sample number, number of samples in average, date and time)

Setup for Deployment

1. Install new AA lithium cells (see *Section 5: Routine Maintenance and Calibration*) or ensure the existing battery pack has enough capacity to cover the intended deployment.
2. Program the MicroCAT for the intended deployment (see *Section 3: Preparing MicroCAT for Deployment* for connection information; see information in this section on commands and sampling modes):
 - A. Ensure all data has been uploaded, and then send **#iiInitLogging** to make the entire memory available for recording.
If **#iiInitLogging** is not sent, data will be stored after the last recorded sample.
 - B. Set the date and time. Note that the date and time can be set globally for all MicroCATs online (**DateTime=**) or individually for each MicroCAT (**#iiDateTime=**). To synchronize autonomous sampling for a system with multiple MicroCATs on a mooring cable, set the date and time globally, with all the MicroCATs online (see *Autonomous Sampling* in this section for details on synchronization).
 - C. Establish the setup and logging parameters.
 - D. If the system will have multiple MicroCATs (or other IM instruments) on the mooring cable, verify that SeatermIM is set to *Use fixed ID* to allow use of SeatermIM's Send Commands window:
 - 1) In the Communications menu, select *Configure*.
 - 2) Click on *Use fixed ID*. Enter the MicroCAT's ID.
 - 3) Click OK.
 - E. Use **one** of the following sequences to initiate logging:
 - **#iiStartNow** to start logging now, taking a sample every **#iiSampleInterval** seconds.
 - **#iiStartDateTime=** and **#iiStartLater** to start logging at the specified date and time, taking a sample every **#iiSampleInterval** seconds.
 - **ResumeLogging** or **GData** to globally start logging now for all MicroCATs online, taking a sample every **#iiSampleInterval** seconds.
3. If you will be using SeatermIM to view occasional data samples while logging, click Capture to save the data to a file. Note that this file **cannot be processed by SBE Data Processing, as it does not have the required headers and format for Sea-Bird's processing software.**

Attaching MicroCAT to Mooring Cable

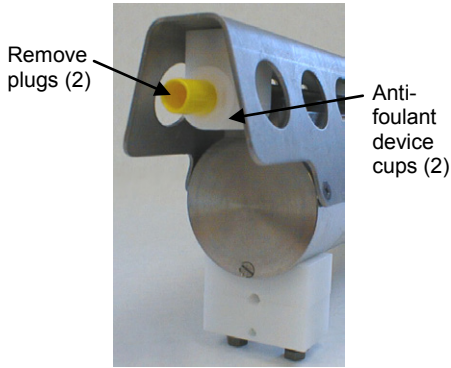

Note:

See *Application Note 85: Handling of Ferrite Core on Instruments with Inductive Modem Telemetry* for more detailed information on handling and installation.

1. New MicroCATs are shipped with AF24173 Anti-Foulant Devices and protective plugs pre-installed.
 - A. Remove the protective plugs, if installed, from the anti-foulant device cups. **The protective plugs must be removed prior to deployment or pressurization.** If the plugs are left in place during deployment, the sensor will not register conductivity. If left in place during pressurization, the cell may be destroyed.
 - B. Verify that the anti-foulant device cups contain AF24173 Anti-Foulant Devices (see *Section 5: Routine Maintenance and Calibration*).
2. Attach the mounting brackets to the insulated mooring cable:
 - A. Open each mounting bracket by unthreading the two large titanium hex bolts.
 - B. Place the insulated mooring cable inside the brackets' grooves.
 - C. Reinstall each bracket half with the hex bolts.
 - D. Verify that the two halves of the modem coupling toroid have come together evenly, and that the mounting clamp is secure.

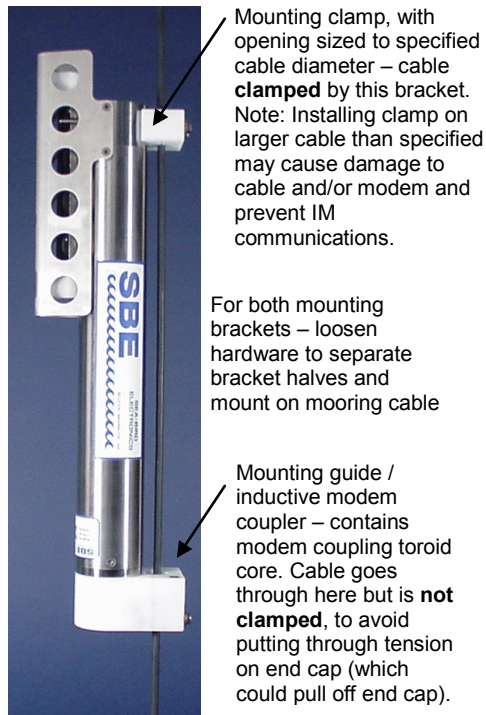

3. Verify that the hardware and external fittings are secure.

Mounting guide / Inductive Modem Coupler Detail

Guide is sized *slightly* bigger than specified cable diameter, to allow cable to pass through freely but limit vibration of MicroCAT on cable

For proper communications, 2 halves of modem coupling toroid core must mate, with no gaps

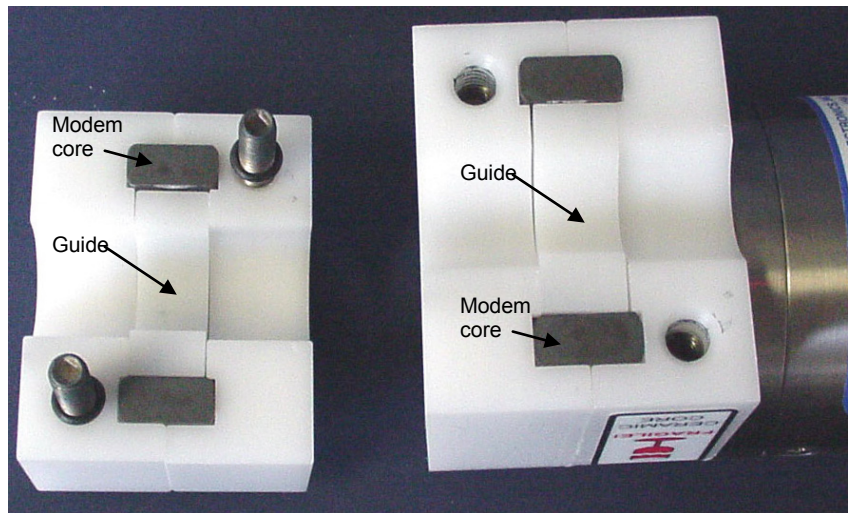

System Installation and Wiring

For system installation and wiring details, refer to:

- *Mooring Cable and Wiring Requirements* in *Section 2: Description of MicroCAT*
- *Appendix IV: SIM Hookup and Configuration* or *IMM manual*.

Installing Optional Inductive Cable Coupler (ICC)

1. Loosen the titanium hex head bolts connecting the two halves of each of the ICC brackets. Pull the halves apart.
2. Place the insulated mooring cable inside the brackets' grooves.
3. Reinstall each bracket half with the hex bolts.
4. Verify that the two halves of the modem coupling toroid have come together evenly, and that the mounting clamp is secure.

Note:

See *Application Note 85: Handling of Ferrite Core on Instruments with Inductive Modem Telemetry* for more detailed information on handling and installation.

Mounting clamp, with opening sized to specified cable diameter – cable **clamped** by this bracket. Note: Installing clamp on larger cable than specified may cause damage to cable and/or modem and prevent IM communications.

Mounting guide / inductive modem coupler – contains modem coupling toroid. Cable goes through here but is **not clamped**, to avoid putting through tension on end cap (which could pull off end cap). **Detail of guide and core is similar to shown above for the 37-IM guide and core.**

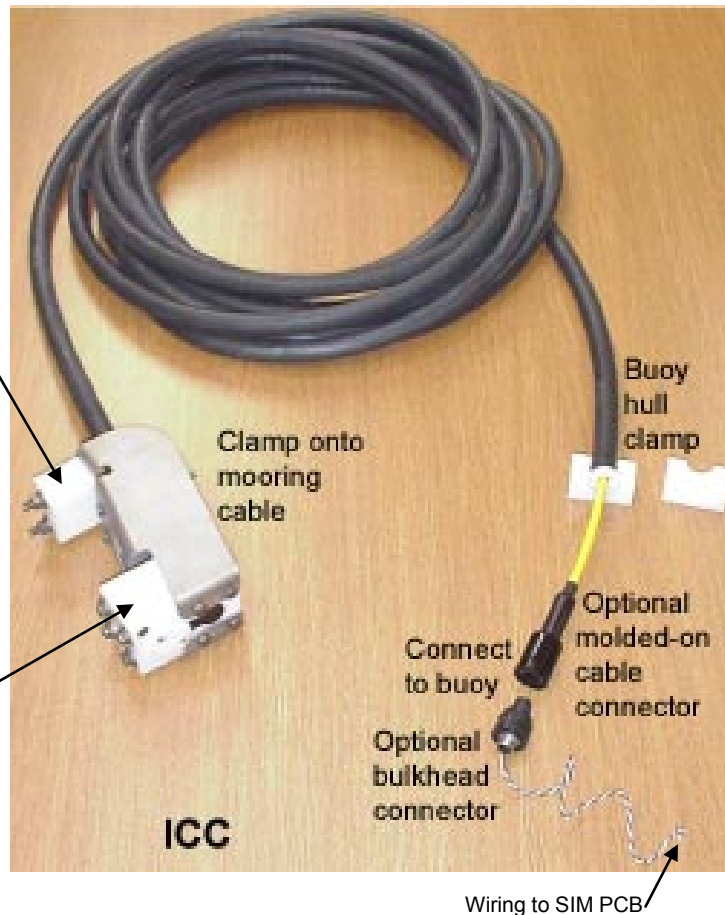

Recovery

WARNING!

If the MicroCAT stops working while underwater, is unresponsive to commands, or shows other signs of flooding or damage, carefully secure it away from people until you have determined that abnormal internal pressure does not exist or has been relieved. Pressure housings may flood under pressure due to dirty or damaged o-rings, or other failed seals. When a sealed pressure housing floods at great depths and is subsequently raised to the surface, water may be trapped at the pressure at which it entered the housing, presenting a danger if the housing is opened before relieving the internal pressure. Instances of such flooding are rare. However, a housing that floods at 5000 meters depth holds an internal pressure of more than 7000 psia, and has the potential to eject the end cap with lethal force. A housing that floods at 50 meters holds an internal pressure of more than 85 psia; this force could still cause injury.

If you suspect the MicroCAT is flooded, point it in a safe direction away from people. There are 4 socket head cap screws securing the conductivity cell tray to the end cap. There is an o-ring face seal between the cell tray and end cap. Using a 9/64 inch Allen hex key, loosen each screw 1/4-turn, in a crossing pattern, while looking for signs of internal pressure (hissing or water leakage). If no sign of pressure is detected, continue to loosen the screws in 1/4-turn increments until the cell tray is loose and the o-ring seal is broken. If internal pressure is detected, let it bleed off slowly. Then, you can safely remove the end cap.

The seals and surrounding surfaces must be properly cleaned before remounting the cell tray; we recommend that this work be performed at Sea-Bird. Remount the tray (to secure the conductivity cell for transport) and send the MicroCAT to Sea-Bird for servicing, with a note that the cell tray o-ring seals have been broken.

1. Rinse the MicroCAT and conductivity cell with fresh water. (See *Section 5: Routine Maintenance and Calibration* for cell cleaning and storage.)
2. Reinsert the protective plugs in the anti-foulant device cups.
3. If the battery pack is exhausted, new cells must be installed before the data can be uploaded. Stored data will not be lost as a result of exhaustion or removal of the battery pack. See *Section 5: Routine Maintenance and Calibration* for replacement of cells.
4. If immediate redeployment is not required, it is best to leave the MicroCAT with battery pack in place and in a quiescent (sleep) state (**PwrOff**), so that date and time are retained. The quiescent current required is only 120 microAmps (less than 12% loss per year).

Uploading and Processing Data

Upload data using one of these telemetry methods:

Note:

The uploaded data format is the same, regardless of the choice of upload telemetry (IM or RS-232) and type (ASCII or binary).

- **RS-232 (serial mode)** - Much faster upload (up to 115,200 baud) is available in serial mode; however, you must remove the battery end cap to access the internal RS-232 serial connector. The RS-232 telemetry allows ASCII or binary upload; binary upload is inherently twice as fast as ASCII upload. When using RS-232 telemetry, select *SBE 37 RS232* in SeatermV2's Instrument menu; this launches **Seaterm232**.
- **Inductive modem** – Data can be uploaded while the MicroCAT is deployed, or is wired in the lab as shown in *Test Setup with SIM* or *Test Setup with IMM* in *Section 3: Preparing MicroCAT for Deployment*. Upload speed is limited by the baud rate between the MicroCAT and IMM/SIM, which is 1200 baud. We recommend uploading with IM telemetry only if you are interested in looking at a small amount of data or need to upload the data without recovering the instrument.

Each upload method is detailed separately below.

Upload Using RS-232 (Serial Mode) Telemetry

Note:

You cannot change the RS-232 baud rate while communicating using RS-232 telemetry.



Holding wire cluster near connector, pull gently to detach female end of connector from pins. Plug data I/O cable (PN 801836) into connector.

1. Connect to the MicroCAT using IM telemetry (see *Section 3: Preparing MicroCAT for Deployment*). Set the baud rate that you want to use for the upload, using `#iiBaudRate=` (600, 1200, 2400, 4800, 9600, 19200, 38400, 57600, or 115200). Disconnect from the MicroCAT. Disconnect the SIM or IMM from the computer.
2. Remove the battery end cap from the housing (see *Battery Installation in Section 3: Preparing MicroCAT for Deployment* for details).
3. Unplug the end cap wiring from the Molex connector. Attach the optional RS-232 data I/O cable (PN 801836) to the Molex connector and to the computer.
4. Double click on **SeatermV2.exe**. The main screen appears.
5. In the Instruments menu, select **SBE 37 RS232 (not SBE 37 IM)**. **Seaterm232** opens.
6. Seaterm232 tries to automatically connect to the MicroCAT. As it connects, it sends **GetHD** and displays the response. Seaterm232 also fills the Send Commands window with the correct list of commands for your MicroCAT. **If there is no communication:**
 - A. In the Communications menu, select *Configure*. The Serial Port Configuration dialog box appears. Select the Comm port and baud rate for communication, and click OK. Note that the factory-set baud rate is documented on the Configuration Sheet.
 - B. In the Communications menu, select *Connect* (if *Connect* is grayed out, select *Disconnect and reconnect*). Seaterm232 will attempt to connect at the baud specified in Step A, but if unsuccessful will then cycle through all other available baud rates.
 - C. If there is still no communication, check cabling between the computer and MicroCAT.
 - D. If there is still no communication, repeat Step A with a different comm port, and try to connect again.
7. If sampling autonomously, command the MicroCAT to stop logging by pressing any key, typing **Stop**, and pressing the Enter key.
8. Display MicroCAT status information by typing **DS** and pressing the Enter key. The display looks like this:

```
SBE37-IM V 3.0e SERIAL NO. 1000 18 Oct 2012 09:00:19
vMain = 8.49, vLith = 2.84
samplenum = 6, free = 559234
not logging, stop command
sample interval = 20 seconds
data format = converted engineering
compatible mode disabled
transmit sample number
transmit sample HEX time
pump installed = no
PC baud rate = 9600
```

Verify that the status is **not logging**.

Note:

You may need to send **Stop** several times to get the MicroCAT to respond.

9. Click the Upload menu to upload stored data. Seaterm232 responds as follows:
 - A. Seaterm232 sends **GetHD** and displays the response, verifying that it is communicating with the 37-IM.
 - B. Seaterm232 sends **OutputExecutedTag=Y**, which is necessary for the upload process.
 - C. Seaterm232 sends **GetSD** and displays the response, providing information on the number of samples in memory.
 - D. In the Save As dialog box, enter the desired upload file name and click Save. The upload file has a .XML extension.
 - E. An Upload Data dialog box appears:

Note:
 If binary upload is selected, Seaterm232 uploads the data in binary and then converts it to ASCII text, resulting in a data file that is identical to one uploaded in ASCII text.

Select number of bytes uploaded in each block. Seaterm232 uploads data in blocks, and calculates a checksum at end of each block. If block fails checksum verification, Seaterm232 tries to upload block of data again, cutting block size in half.

Defines data upload type and range:

- All data as a single file – All data is uploaded into 1 file.
- By scan number range – Enter beginning scan (sample) number and total number of scans. All data within range is uploaded into 1 file.

To change upload file name selected in Step D above, click Browse to navigate to desired upload file path and name. Upload file has a .xml extension. After Seaterm232 uploads data into .xml data file, it creates .hex data file and .xmlcon configuration file that are compatible with SBE Data Processing. These files are placed in same directory as .xml data file, and have same name (but different extensions).

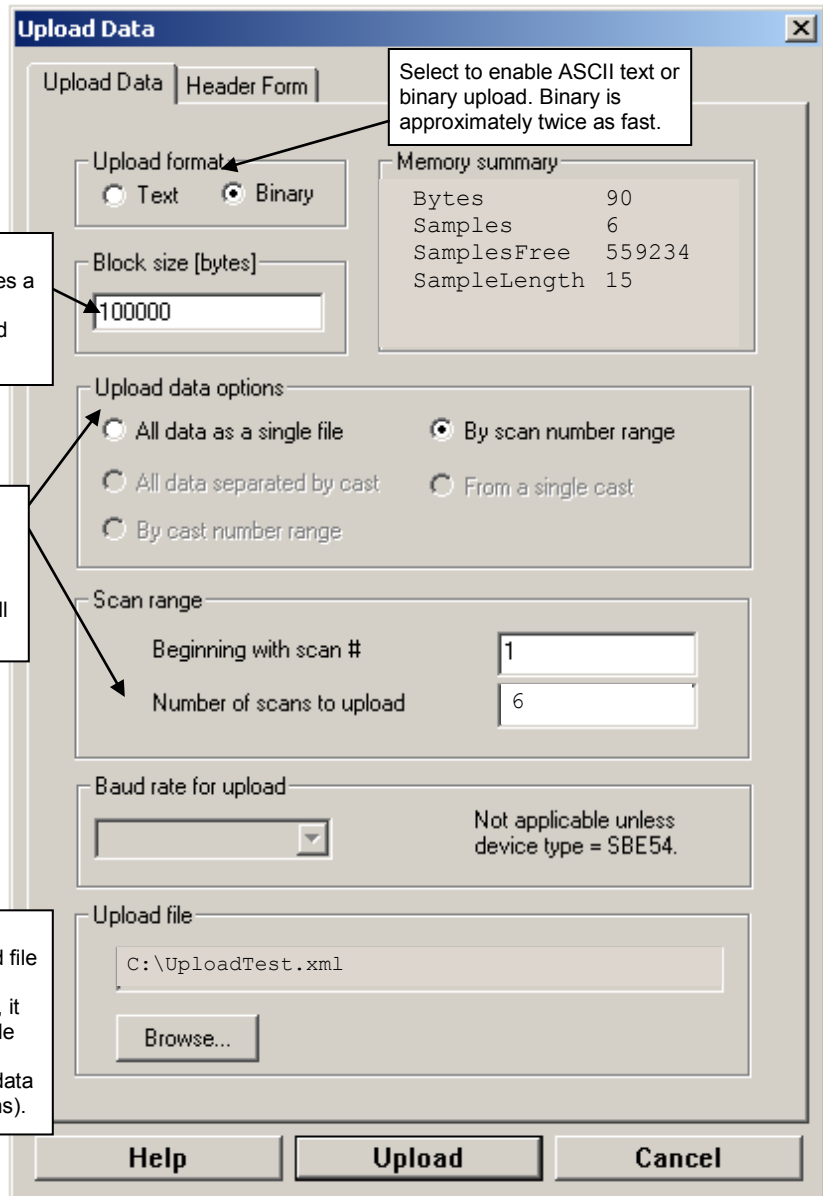

Make the desired selections.

10. Click the Header Form tab to customize the header:

Defines header information included with uploaded data:

- Prompt for header information – As data is uploaded, user is prompted to fill out user-defined header form.
- Include default header form in upload file – User-defined default header form included in upload file. User is not prompted to add any information when data is uploaded.
- Don't include default header form in upload file – Header information not included in upload file.

The entries are free form, 0 to 12 lines long. This dialog box establishes:

- the header prompts that appear for the user to fill in when uploading data, if *Prompt for header information* was selected
- the header included with the uploaded data, if *Include default header form in upload file* was selected

Enter the desired header/header prompts.

11. Click Upload; the Status bar at the bottom of the window displays the upload progress.
 - A. Seaterm232 sends several status commands providing information regarding the number of samples in memory, calibration coefficients, etc., and writes the responses to the upload .xml file.
 - B. **If you selected *Prompt for header information in the Upload Data dialog box*** – a dialog box with the header form appears. Enter the desired header information, and click OK. Seaterm232 writes the header information to the upload .xml file.
 - C. Seaterm232 sends the data upload command, based on your selection of upload range in the Upload Data dialog box, and writes the data to the upload .xml file.
 - D. From the information in the .xml file, Seaterm232 creates a .hex data file and a .xmlcon configuration file that are compatible with SBE Data Processing for processing and plotting the data. These files are placed in the same directory as the .xml data file and have the same name (but different extensions).
12. After the data has been uploaded, Seaterm232 prompts you to run SBE Data Processing's Data Conversion module if desired. Data Conversion converts the .hex (raw data) file to a .cnv file, which can then be processed by other modules in SBE Data Processing. See *Processing Data* below.
13. Remove the data I/O cable from the Molex connector. Reinstall the wiring from the end cap to the Molex connector, and reinstall the end cap in the housing (see *Battery Installation in Section 3: Preparing MicroCAT for Deployment* for details).

Note:

SeatermV2 with version < 1.1 did not convert the uploaded .xml data file to a .hex and .xmlcon file. *Convert .XML data file* in the Tools menu was used to convert the .xml data file to a .cnv file, which could be processed in SBE Data Processing. We recommend that you update your SeatermV2 software to 1.1b or later.

Upload Using Inductive Modem Telemetry (recommended only for uploading small amounts of data)

Note:

Data may be uploaded during deployment or after recovery. If uploading after recovery, wire the MicroCAT and SIM or IMM as described in *Power and Communications Test and Setting MicroCAT IDs in Section 3: Preparing MicroCAT for Deployment*.

1. Double click on **SeatermV2.exe**. The main screen appears.
2. In the Instruments menu, select *SBE 37 IM*. **SeatermIM** opens.
3. SeatermIM first sends commands to determine if it is connected to a SIM or an IMM, and sends the appropriate command to wake up all IM instruments on the line. The remaining connection attempt varies, depending on the configuration setting the last time SeatermIM was used:
 - If SeatermIM was set to *Automatically get instrument ID* the last time it was used – SeatermIM sends **id?** and waits for a response from the MicroCAT. Once the ID response is received, SeatermIM sends **!iiGetHD** and **#iiGetHD**, using the ID provided by the MicroCAT.
 - If SeatermIM was set to *Use fixed ID* the last time it was used – SeatermIM sends **!iiGetHD** and **#iiGetHD**, using the fixed ID that was entered the last time the software was used.

SeatermIM then fills the Send Commands window with the correct list of commands for your MicroCAT.

If there is no communication (no response to **id?** and/or no response to **!iiGetHD** and/or **#iiGetHD**):

- A. In the Communications menu, select *Configure*. The Configure Communications dialog box appears. Select the Comm port and baud rate for communication. Note that the factory-set baud rate is documented on the Configuration Sheet. If using a fixed ID, verify that the designated ID is correct for the MicroCAT with which you want to communicate. Click OK.
 - B. In the Communications menu, select *Connect* (if *Connect* is grayed out, select *Disconnect and reconnect*). SeatermIM will attempt to connect at the baud specified in Step A, but if unsuccessful will then cycle through all other available baud rates.
 - C. If there is still no communication, check cabling between the computer, SIM or IMM, and MicroCAT, and try to connect again.
 - D. If there is still no communication, repeat Step A with a different comm port and/or different fixed ID, and try to connect again.
4. If sampling autonomously, command the MicroCAT to stop logging by typing **#iiStop** (ii=MicroCAT ID) and pressing the Enter key.
 5. Display MicroCAT status information by typing **#iiDS** (ii=MicroCAT ID) and pressing the Enter key. The display looks like this:

```
SBE37-IM V 3.0e SERIAL NO. 1000 18 Oct 2012 09:00:19
vMain = 8.49, vLith = 2.84
samplenumber = 6, free = 559234
not logging, stop command
sample interval = 20 seconds
data format = converted engineering
compatible mode disabled
transmit sample number
transmit sample HEX time
pump installed = no
PC baud rate = 9600
```

Verify that the status is **not logging**.

Note:

You may need to send **#iiStop** several times to get the MicroCAT to respond.

6. Click the Upload menu to upload stored data. SeatermIM responds as follows:
 - A. SeatermIM sends a wake-up tone.
 - B. Seaterm232 sends **#iiGetHD** and displays the response, verifying that it is communicating with the 37-IM.
 - C. SeatermIM sends **#iiOutputExecutedTag=Y**, which is necessary for the upload process.
 - D. SeatermIM sends **#iiGetSD** and displays the response, providing information on the number of samples in memory.
 - E. In the Save As dialog box, enter the desired upload file name and click Save. The upload file has a .XML extension.
 - F. An Upload Data dialog box appears:

Select number of bytes uploaded in each block. SeatermIM uploads data in blocks, and calculates a checksum at end of each block. If block fails checksum verification, SeatermIM tries to upload block of data again, cutting block size in half.

Defines data upload type and range:

- All data as a single file – All data is uploaded into 1 file.
- By scan number range – Enter beginning scan (sample) number and total number of scans. All data within range is uploaded into 1 file.

To change upload file name selected in Step E above, click Browse to navigate to desired upload file path and name. Upload file has a .xml extension. After SeatermIM uploads data into .xml file, it automatically converts .xml file to .hex file (same file name, different extension), which is compatible with Seasave and SBE Data Processing.

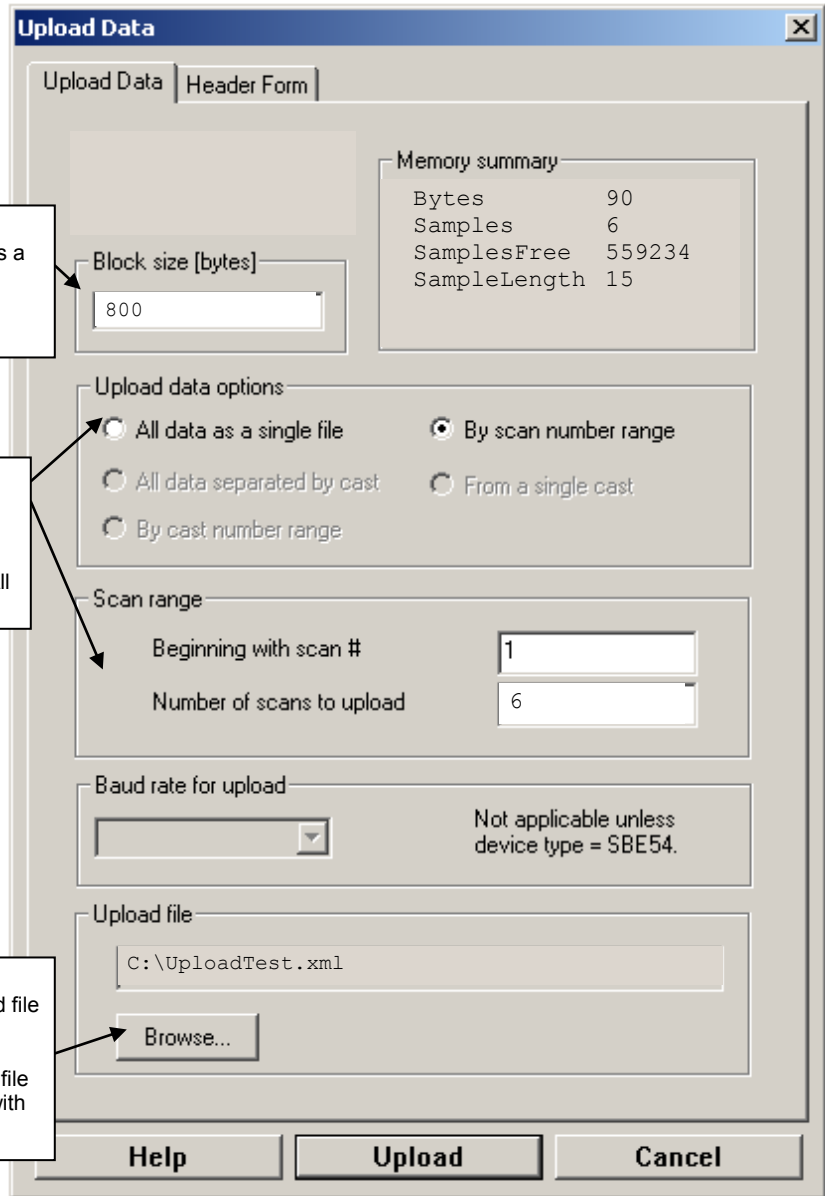

Make the desired selections.

7. Click the Header Form tab to customize the header:
The entries are free form, 0 to 12 lines long. This dialog box establishes:

Defines header information included with uploaded data:

- Prompt for header information – As data is uploaded, user is prompted to fill out user-defined header form.
- Include default header form in upload file – User-defined default header form included in upload file. User is not prompted to add any information when data is uploaded.
- Don't include default header form in upload file – Header information not included in upload file.

- the header prompts that appear for the user to fill in when uploading data, if *Prompt for header information* was selected
 - the header included with the uploaded data, if *Include default header form in upload file* was selected
- Enter the desired header/header prompts.

8. Click Upload; the Status bar at the bottom of the window displays the upload progress.
- SeatermIM sends several status commands providing information regarding the number of samples in memory, calibration coefficients, etc., and writes the responses to the upload .xml file.
 - If you selected *Prompt for header information* in the Upload Data dialog box** – a dialog box with the header form appears. Enter the desired header information, and click OK. SeatermIM writes the header information to the upload .xml file.
 - SeatermIM sends the data upload command, based on your selection of upload range in the Upload Data dialog box, and writes the data to the upload .xml file.
 - From the information in the .xml file, SeatermIM creates a .hex data file and a .xmlcon configuration file that are compatible with SBE Data Processing for processing and plotting the data. These files are placed in the same directory as the .xml data file and have the same name (but different extensions).
9. After the data has been uploaded, SeatermIM prompts you to run SBE Data Processing's Data Conversion module if desired. Data Conversion converts the .hex (raw data) file to a .cnv file, which can then be processed by other modules in SBE Data Processing. See *Processing Data* below.

Note:

SeatermV2 with version < 1.1 did not convert the uploaded .xml data file to a .hex and .xmlcon file. *Convert .XML data file* in the Tools menu was used to convert the .xml data file to a .cnv file, which could be processed in SBE Data Processing. We recommend that you update your SeatermV2 software to 1.1b or later.

Notes:

- Ensure all data has been uploaded from the MicroCAT by reviewing the data in SBE Data Processing.
- If you do not run Data Conversion now, you can run it later by opening SBE Data Processing.
- See the SBE Data Processing manual and/or Help for details.

Processing Data

1. After the data has been uploaded, Seaterm232 (if you uploaded via the internal RS-232 connector) or SeatermIM (if you uploaded via inductive modem telemetry) prompts you to run SBE Data Processing's Data Conversion module if desired. Data Conversion converts the .hex (raw data) file to a .cnv file, which can then be processed by other modules in SBE Data Processing.

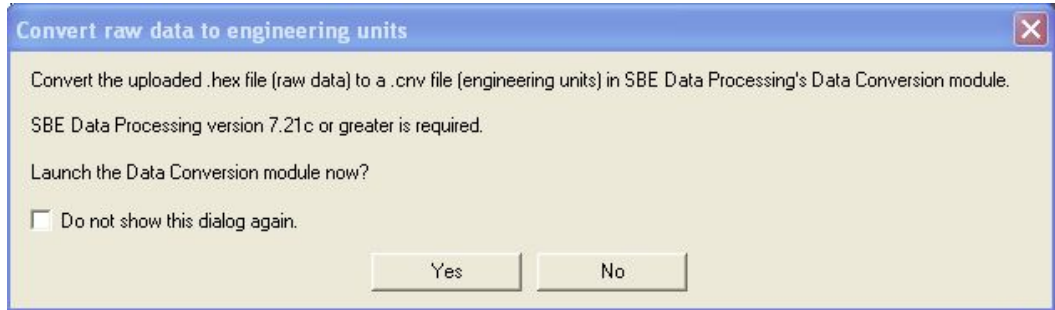

- A. If you click Yes, Seaterm232 or SeatermIM opens SBE Data Processing's Data Conversion module, and fills in the appropriate instrument configuration (.xmlcon) file and data (.hex) file on the File Setup tab.

Location to store all setup information. Default is directory with SeatermV2 application data, when Data Conversion is launched from Seaterm232 or SeatermIM.

Instrument configuration (.xmlcon) file location, which is created by Seaterm232 or SeatermIM, and contains MicroCAT's calibration coefficients (see dialog box below).

Directory and file name for raw data (.hex) file created by Seaterm232 or SeatermIM from uploaded data.

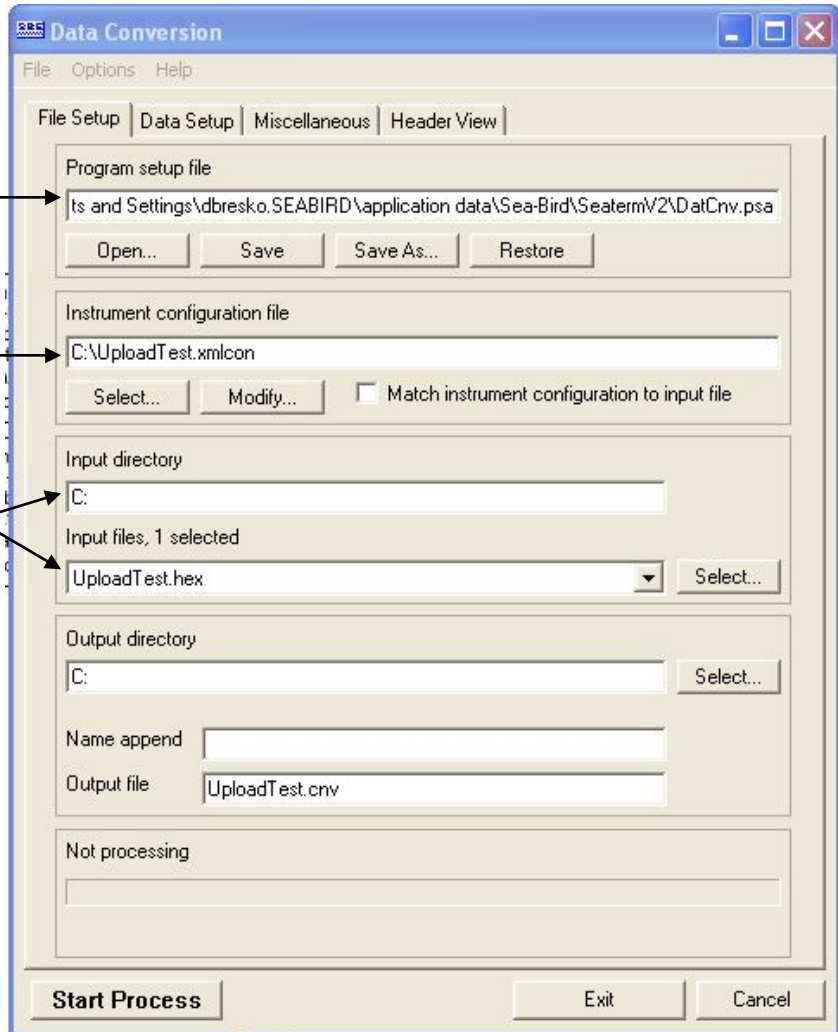

The Configuration dialog box (which appears if you click *Modify* on the File Setup tab) looks like this:

The screenshot shows the 'Configuration for the SBE 37 Microcat' dialog box. The configuration file is 'UploadTest.xmlcon'. The sample interval is set to 10 seconds. The pressure sensor is disabled. The oxygen sensor is set to 'None'. The deployment pressure is 100 dbar. The deployment latitude is 0. The 'Use deployment latitude in depth calculations' checkbox is unchecked. The sensor list shows '1. Count' with 'Temperature' and '2. Frequency' with 'Conductivity'. The dialog includes buttons for 'New', 'Open...', 'Save', 'Save As...', 'Modify...', 'Report...', 'Help...', 'Exit', and 'Cancel'.

Indicates if MicroCAT includes pressure sensor. If no pressure sensor included, deployment pressure is used to calculate conductivity (and derived variables such as salinity and sound velocity). Value shown is based on **#iiReferencePressure=** that was programmed into MicroCAT; **you can change this value in .xmlcon file, if you have updated deployment depth information.**

Time between scans. Must agree with MicroCAT setup (**#iiSampleInterval=**); see reply from **#iiGetCD** or **#iiDS**.

Indicates whether MicroCAT includes dissolved oxygen sensor (IDO or ODO MicroCATs only).

Latitude is used to calculate local gravity (to calculate salt water depth). If enabled, software uses input latitude in calculation. If disabled, software uses Latitude on Miscellaneous tab of Data Conversion. **Enter latitude for your deployment.**

Double click on sensor to view and/or modify calibration coefficients, which are based on calibration coefficients that were programmed into MicroCAT.

Channel	Sensor
1. Count	Temperature
2. Frequency	Conductivity

The settings in the .xmlcon file created by Seaterm232 or SeatermIM are based on the setup of the MicroCAT.

- Review the deployment latitude, and modify as needed.
- If your MicroCAT does not have a pressure sensor, review the deployment pressure, and modify as needed.

Click Save if you made any changes, and then click Exit.

B. Click on the Data Setup tab.

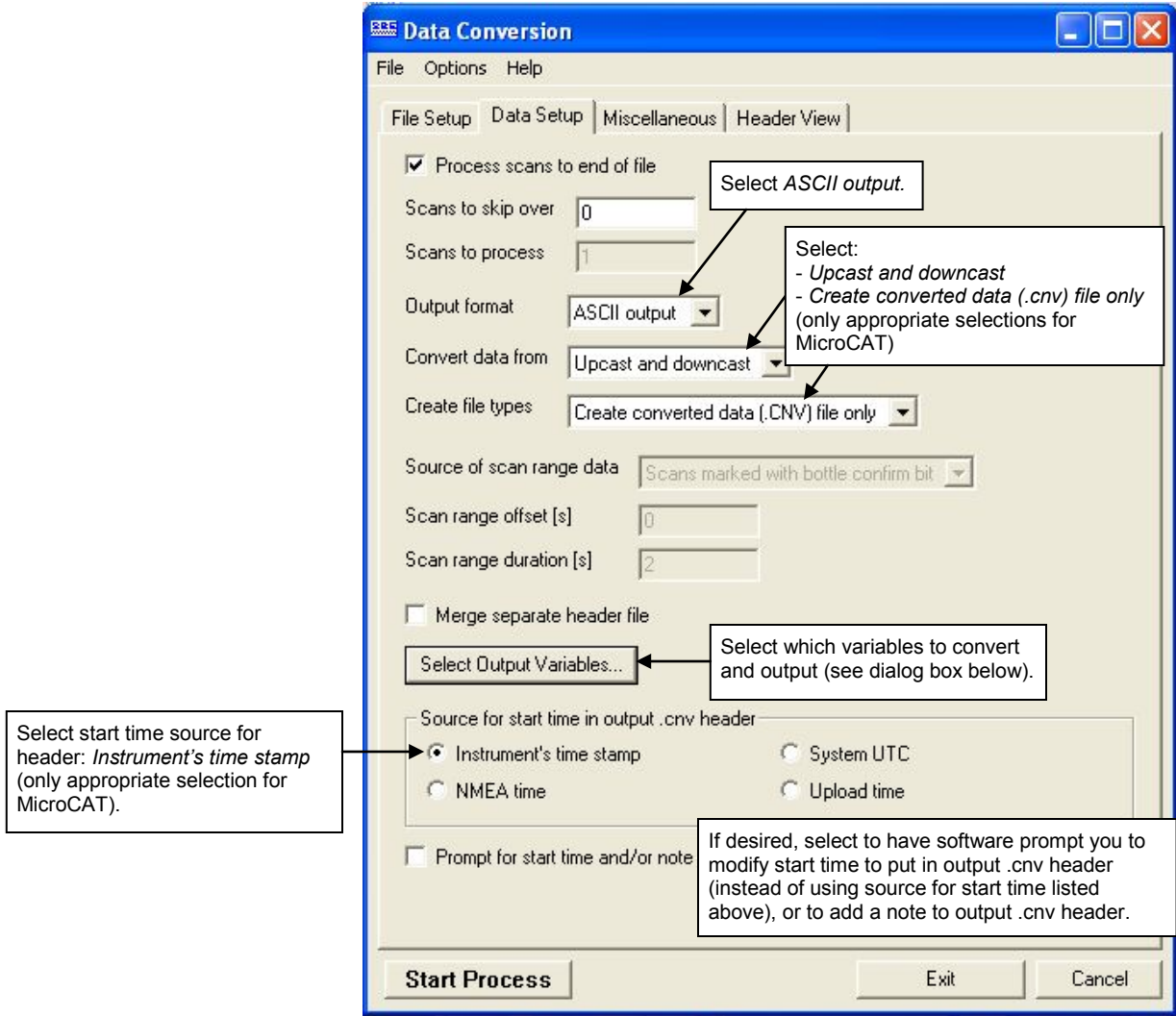

The Select Output Variables dialog box (which appears when you click *Select Output Variables* on the Data Setup tab) looks like this:

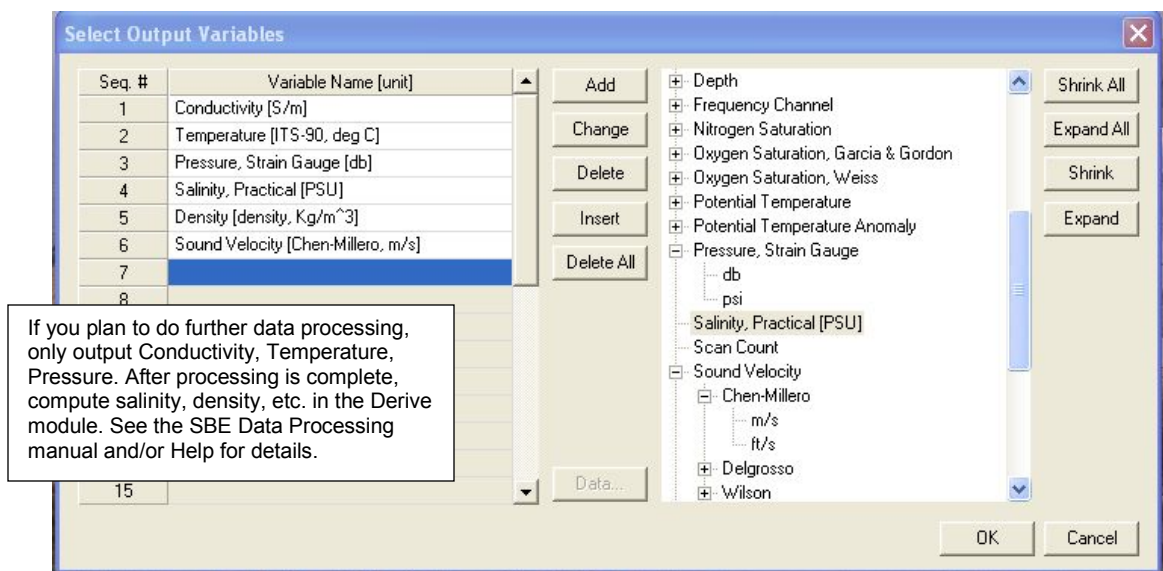

Select Temperature, Conductivity, and Pressure (optional), as well as desired derived variables such as salinity, sound velocity, etc. Click OK.

C. At the bottom of the Data Conversion dialog box, click Start Process to convert the .hex file to a .cnv file.

Notes:

To prepare for re-deployment:

1. After all data is uploaded, send **#iiInitLogging**. If not sent, new data will be stored after the last sample, preventing use of the entire memory.
2. Do *one* of the following:
 - Send **PwrOff** to put the MicroCAT in quiescent (sleep) state until ready to redeploy. Quiescent current is only 120 microAmps, so the battery pack can be left in place without significant loss of capacity.
 - Use **#iiStartNow**, **ResumeLogging**, or **GData** to begin logging immediately.
 - Set a date and time for logging to start using **#iiStartDateTime=** and **#iiStartLater**.

2. Once the data is converted to a .cnv file, use the other SBE Data Processing modules as desired:
 - Derive module - Calculate additional derived variables.
 - Sea Plot module - Plot data.

Editing Raw Data File

Sometimes users want to edit the raw .hex data file before beginning processing, to remove data at the beginning of the file corresponding to instrument *soak* time, remove blocks of bad data, edit the header, or add explanatory notes. **Editing the raw .hex file can corrupt the data, making it impossible to perform further processing using Sea-Bird software.** Sea-Bird strongly recommends that you first convert the data to a .cnv file (using the Data Conversion module in SBE Data Processing), and then use other SBE Data Processing modules to edit the .cnv file as desired.

Note:

Although we provide this technique for editing a raw .hex file, **Sea-Bird's strong recommendation, as described above, is to always convert the raw data file and then edit the converted file.**

The procedure described below for editing a .hex data file has been found to work correctly on computers running Windows 98, 2000, and NT. **If the editing is not performed using this technique, SBE Data Processing may reject the edited data file and give you an error message.**

1. **Make a back-up copy of your .hex data file before you begin.**
2. Run **WordPad**. In the File menu, select Open. The Open dialog box appears. For *Files of type*, select *All Documents (*.*)*. Browse to the desired .hex file and click Open.
3. Edit the file as desired, **inserting any new header lines after the System Upload Time line**. Note that all header lines must begin with an asterisk (*), and *END* indicates the end of the header. An example is shown below (for an SBE 21), with the added lines in bold:

```
* Sea-Bird SBE 21 Data File:
* FileName = C:\Odis\SAT2-ODIS\oct14-19\oc15_99.hex
* Software Version Seasave Win32 v1.10
* Temperature SN = 2366
* Conductivity SN = 2366
* System Upload Time = Oct 15 1999 10:57:19
* Testing adding header lines
* Must start with an asterisk
* Place anywhere between System Upload Time & END of header
* NMEA Latitude = 30 59.70 N
* NMEA Longitude = 081 37.93 W
* NMEA UTC (Time) = Oct 15 1999 10:57:19
* Store Lat/Lon Data = Append to Every Scan and Append to .NAV
File When <Ctrl F7> is Pressed
** Ship:          Sea-Bird
** Cruise:       Sea-Bird Header Test
** Station:
** Latitude:
** Longitude:
*END*
```
4. In the File menu, select Save (**not Save As**). If you are running Windows 2000, the following message displays:
You are about to save the document in a Text-Only format, which will remove all formatting. Are you sure you want to do this?
Ignore the message and click *Yes*.
5. In the File menu, select Exit.

Section 5: Routine Maintenance and Calibration

This section reviews corrosion precautions, conductivity cell cleaning and storage, plastic housing handling instructions, replacement of AA cells, O-ring maintenance, pressure sensor maintenance, replacement of AF24173 Anti-Foulant Devices, and sensor calibration. The accuracy of the MicroCAT is sustained by the care and calibration of the sensors and by establishing proper handling practices.

Corrosion Precautions

Rinse the MicroCAT with fresh water after use and prior to storage.

All exposed metal is titanium; other materials are plastic. No corrosion precautions are required, but avoid direct electrical connection of the MicroCAT housing to mooring or other dissimilar metal hardware.

Conductivity Cell Maintenance

CAUTIONS:

- **Do not put a brush or any object inside the conductivity cell to clean it.** Touching and bending the electrodes can change the calibration. Large bends and movement of the electrodes can damage the cell.
- **Do not store the MicroCAT with water in the conductivity cell.** Freezing temperatures (for example, in Arctic environments or during air shipment) can break the

The MicroCAT's conductivity cell is shipped dry to prevent freezing in shipping. Refer to *Application Note 2D: Instructions for Care and Cleaning of Conductivity Cells* for conductivity cell cleaning procedures and cleaning materials.

- The Active Use (after each cast) section of the application note is not applicable to the MicroCAT, which is intended for use as a moored instrument.

A conductivity cell filling and storage kit is available from Sea-Bird. The kit (PN 50087.1) includes a syringe and tubing assembly, and two anti-foulant device caps with hose barbs. The tubing cannot attach to an anti-foulant device cap that is not barbed.

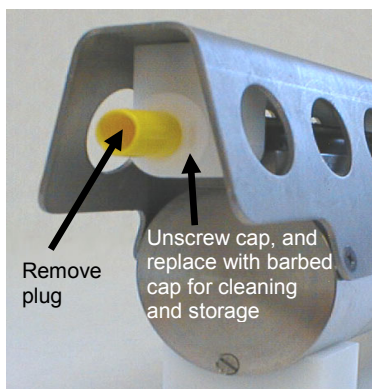

Cleaning and storage instructions require use of the syringe and tubing assembly at the intake end of the cell (requiring one barbed cap), and looping Tygon tubing from end to end of the cell (requiring two barbed caps). Remove the installed anti-foulant device cap(s) and replace them with the anti-foulant device cap(s) with hose barbs **for cleaning and storage only**. Remember to reinstall the original anti-foulant device cap(s) before deployment. **Deploying a MicroCAT with barbed anti-foulant device cap(s) in place of the installed caps is likely to produce undesirable results in your data.** See *Replacing Anti-Foulant Devices* for safety precautions when handling the AF24173 Anti-Foulant Devices.

Handling Instructions for Plastic *ShallowCAT*



See detail below

Hex screw securing modem end cap (one each side)



Detail - Modem end cap

The MicroCAT's 7000-meter titanium housing offers the best durability with a modest amount of care. The *ShallowCAT*, a 350-meter plastic housing, saves money and weight. However, more care and caution in handling is required. To get the same excellent performance and longevity for the plastic-housing version:

- The MicroCAT's modem end cap is retained by two screws through the side of the housing. The screw holes are close to the end of the housing. Particularly in a cold environment, where plastic is more brittle, the potential for developing a crack around the screw hole(s) is greater for the plastic housing than for the titanium housing. Observe the following precautions –
 - When removing the end cap (to replace the AA cells and/or to access the electronics), be careful to avoid any impact in this area of the housing.
 - When reinstalling the end cap, do not use excess torque on the screws. Sea-Bird recommends tightening the screws to 15 inch-lbs. Alternatively, tighten the screws finger-tight, and then turn each screw an additional 45 degrees.
- A plastic housing is more susceptible to scratches than a titanium housing. Do not use screwdrivers or other metal tools to pry off the end cap.
 - Of primary concern are scratches on O-ring mating and sealing surfaces. Take extra precaution to avoid a scraping contact with these surfaces when replacing AA cells and/or re-seating the end cap.
 - Also take care to keep the O-ring lubricated surfaces clean – avoid trapping any sand or fine grit that can scratch the critical sealing surfaces. If the O-ring lubricant does accumulate any material or grit that can cause a leak or make a scratch, it must be carefully cleaned and replaced with fresh, clean lubricant (Parker Super O Lube).
 - Shallow, external scratches are cosmetic only, and will not affect the performance of the MicroCAT. However, deep external scratches can become points of weakness for deep deployments or fracture from impact during very cold weather.
- If you remove the screws securing the conductivity cell guard to the housing (not typically done by the customer), follow the same precautions as described above for removing and replacing the modem end cap.

See *Battery Pack Installation* in *Section 3: Preparing MicroCAT for Deployment* and *Appendix II: Electronics Disassembly / Reassembly* for detailed step-by-step procedures for removing the MicroCAT's end cap.

Replacing AA Cells

Notes:

- For details and photos, see *Installing Battery Pack* in *Section 3: Preparing MicroCAT for Deployment*.
- **Only use the battery pack with the red cover plate.** Some MicroCATs use a battery pack with a yellow cover plate; those packs are wired differently, and will not work properly in this MicroCAT.
- Cells must be removed before returning the MicroCAT to Sea-Bird. Do not return used cells when shipping the MicroCAT for calibration repair.
- See *Shipping Precautions* in *Section 1: Introduction*.

1. Remove the 2 screws holding the modem end cap to the MicroCAT housing, and remove the end cap.
2. Loosen the captured screw holding the battery pack in the housing, and remove the battery pack from the housing.
3. Place the handle in an upright position. Unscrew the red cover plate from the top of the battery pack assembly.
4. Roll the 2 O-rings on the outside of the pack out of their grooves.
5. Remove the existing cells. Install new cells, positive end (+) first.
6. Roll the O-rings into place in the grooves on the side of the battery pack.
7. Place the handle in an upright position. Reinstall the battery pack cover plate.
8. Replace the battery pack assembly in the housing, and secure the assembly with the captured screw. Plug in the Molex connector, and reinstall the MicroCAT end cap.

O-Ring Maintenance

Note:

For details on recommended practices for cleaning, handling, lubricating, and installing O-rings, see the *Basic Maintenance of Sea-Bird Equipment* module in the Sea-Bird training materials: www.seabird.com/training/TrainingHandouts.htm.

Recommended inspection and replacement schedule:

- For modem end cap O-rings – inspect each time you open the housing to replace the cells or connect to the internal RS-232 connector; replace approximately once a year.
- For O-rings that are not normally disturbed (for example, on the electronics end cap) - approximately every 3 to 5 years.

Remove any water from the O-rings and mating surfaces in the housing with a lint-free cloth or tissue. Inspect O-rings and mating surfaces for dirt, nicks, and cuts. Clean or replace as necessary. Apply a light coat of O-ring lubricant (Parker Super O Lube) to O-rings and mating surfaces.

Pressure Sensor (optional) Maintenance



Pressure sensor port plug

The pressure port plug has a small vent hole to allow hydrostatic pressure to be transmitted to the pressure sensor inside the instrument, while providing protection for the pressure sensor, keeping most particles and debris out of the pressure port.

Periodically (approximately once a year) inspect the pressure port to remove any particles, debris, etc:

1. Unscrew the pressure port plug from the pressure port.
2. Rinse the pressure port with warm, de-ionized water to remove any particles, debris, etc.
3. Replace the pressure port plug.

CAUTION:

Do not put a brush or any object in the pressure port. Doing so may damage or break the pressure sensor.

Replacing Anti-Foulant Devices (SBE 37-SI, SM, IM)



AF24173
Anti-Foulant
Device

The MicroCAT has an anti-foulant device cup and cap on each end of the cell. New MicroCATs are shipped with an Anti-Foulant Device and a protective plug pre-installed in each cup.

WARNING!

AF24173 Anti-Foulant Devices contain bis(tributyltin) oxide. Handle the devices only with rubber or latex gloves. Wear eye protection. Wash with soap and water after handling.

Read precautionary information on product label (see Appendix VI) before proceeding.

It is a violation of US Federal Law to use this product in a manner inconsistent with its labeling.

Wearing rubber or latex gloves, follow this procedure to replace each Anti-Foulant Device (two):

1. Remove the protective plug from the anti-foulant device cup;
2. Unscrew the cap with a $\frac{5}{8}$ -inch socket wrench;
3. Remove the old Anti-Foulant Device. If the old device is difficult to remove:

- Use needle-nose pliers and carefully break up material;
- If necessary, remove the guard to provide easier access.

Place the new Anti-Foulant Device in the cup;

4. Rethread the cap onto the cup. Do not over tighten;
5. If the MicroCAT is to be stored, reinstall the protective plug. **Note that the plugs must be removed prior to deployment or pressurization.** If the plugs are left in place during deployment, the cell will not register conductivity. If left in place during pressurization, the cell may be destroyed.

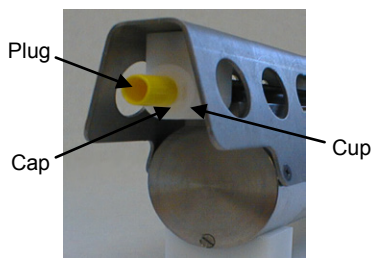
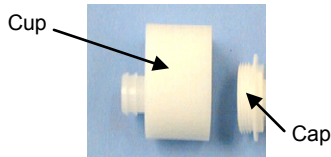

CAUTION:

Anti-foulant device cups are attached to the guard and connected with tubing to the cell. **Removing the guard without disconnecting the cups from the guard will break the cell.** If the guard must be removed:

1. Remove the two screws connecting each anti-foulant device cup to the guard.
2. Remove the four Phillips-head screws connecting the guard to the housing and sensor end cap.
3. Gently lift the guard away.

Sensor Calibration

Notes:

- Cells must be removed before returning the MicroCAT to Sea-Bird. Do not return used cells to Sea-Bird when shipping the MicroCAT for recalibration or repair.
- Please remove AF24173 Anti-Foulant Devices before returning the MicroCAT to Sea-Bird. Store them for future use. See *Replacing Anti-Foulant Devices* for removal procedure.

Sea-Bird sensors are calibrated by subjecting them to known physical conditions and measuring the sensor responses. Coefficients are then computed, which may be used with appropriate algorithms to obtain engineering units. The sensors on the MicroCAT are supplied fully calibrated, with coefficients printed on their respective Calibration Certificates (see back of manual). These coefficients have been stored in the MicroCAT's EEPROM.

We recommend that MicroCATs be returned to Sea-Bird for calibration.

Conductivity Sensor Calibration

The conductivity sensor incorporates a fixed precision resistor in parallel with the cell. When the cell is dry and in air, the sensor's electrical circuitry outputs a frequency representative of the fixed resistor. This frequency is recorded on the Calibration Certificate and should remain stable (within 1 Hz) over time.

The primary mechanism for calibration drift in conductivity sensors is the fouling of the cell by chemical or biological deposits. Fouling changes the cell geometry, resulting in a shift in cell constant.

Accordingly, the most important determinant of long-term sensor accuracy is the cleanliness of the cell. We recommend that the conductivity sensors be calibrated before and after deployment, but particularly when the cell has been exposed to contamination by oil slicks or biological material.

Temperature Sensor Calibration

The primary source of temperature sensor calibration drift is the aging of the thermistor element. Sensor drift will usually be a few thousandths of a degree during the first year, and less in subsequent intervals. Sensor drift is not substantially dependent upon the environmental conditions of use, and — unlike platinum or copper elements — the thermistor is insensitive to shock.

Pressure Sensor (optional) Calibration

The optional strain-gauge pressure sensor is a mechanical diaphragm type, with an initial static error band of 0.05%. Consequently, the sensor is capable of meeting MicroCAT's 0.10% error specification with some allowance for aging and ambient-temperature induced drift.

Pressure sensors show most of their error as a linear offset from zero.

A technique is provided below for making small corrections to the pressure sensor calibration using the *offset* (**#iiPOffset=**) calibration coefficient term by comparing MicroCAT pressure output to readings from a barometer.

Allow the MicroCAT to equilibrate in a reasonably constant temperature environment for at least 5 hours before starting. Pressure sensors exhibit a transient change in their output in response to changes in their environmental temperature. Sea-Bird instruments are constructed to minimize this by thermally decoupling the sensor from the body of the instrument. However, there is still some residual effect; allowing the MicroCAT to equilibrate before starting will provide the most accurate calibration correction.

Note:

The MicroCAT's pressure sensor is an absolute sensor, so its **raw** output (**#iiOutputFormat=3**) includes the effect of atmospheric pressure (14.7 psi). As shown on the Calibration Sheet, Sea-Bird's calibration (and resulting calibration coefficients) is in terms of psia. However, when outputting pressure in **engineering units**, the MicroCAT outputs pressure relative to the ocean surface (i.e., at the surface the output pressure is 0 decibars). The MicroCAT uses the following equation to convert psia to decibars:

$$\text{Pressure (db)} = [\text{pressure (psia)} - 14.7] * 0.689476$$

1. Place the MicroCAT in the orientation it will have when deployed.
2. In SeatermIM:
 - A. Set the pressure offset to 0.0 (**#iiPOffset=0**).
 - B. Set the output format to converted decimal (**#iiOutputFormat=1**), so the pressure output will be in decibars.
 - C. Send **#iiTSN:100** to take 100 samples and transmit data.
3. Compare the MicroCAT output to the reading from a good barometer at the same elevation as the MicroCAT's pressure sensor port. Calculate *offset* = barometer reading – MicroCAT reading
4. Enter the calculated offset (positive or negative) in the MicroCAT's EEPROM, using **#iiPOffset=** in SeatermIM.

Offset Correction Example

Absolute pressure measured by a barometer is 1010.50 mbar. Pressure displayed from MicroCAT is -2.5 dbars.

Convert barometer reading to dbars using the relationship: mbar * 0.01 = dbar

Barometer reading = 1010.50 mbar * 0.01 = 10.1050 dbar

The MicroCAT's internal calculations output gage pressure, using an assumed value of 14.7 psi for atmospheric pressure. Convert MicroCAT reading from gage to absolute by adding 14.7 psia to the MicroCAT's output:

-2.5 dbars + (14.7 psi * 0.689476 dbar/psia) = -2.5 + 10.13 = 7.635 dbars

Offset = 10.1050 – 7.635 = + 2.47 dbars

Enter offset in MicroCAT.

For demanding applications, or where the sensor's air ambient pressure response has changed significantly, calibration using a dead-weight generator is recommended. The pressure sensor port uses a $7/16$ -20 straight thread for mechanical connection to the pressure source. Use a fitting that has an O-ring tapered seal, such as Swagelok-200-1-4ST, which conforms to MS16142 boss.

Section 6: Troubleshooting

This section reviews common problems in operating the MicroCAT, and provides the most common causes and solutions.

Problem 1: Unable to Communicate with MicroCAT

If `#iiOutputExecutedTag=N`, the `S>` prompt indicates that communications between the MicroCAT and computer have been established. Before proceeding with troubleshooting, attempt to establish communications again by selecting *Connect* in the Communications menu in SeatermIM.

Cause/Solution 1: The I/O cable connection may be loose. Check the cabling between the SIM or IMM and computer for a loose connection.

Cause/Solution 2: The instrument type and/or its communication settings may not have been entered correctly in SeatermIM. Verify the settings in the Configure Communications dialog box (Communications menu -> *Configure*). The settings should match those on the instrument Configuration Sheet.

Cause/Solution 3: The I/O cable between the SIM or IMM and computer may not be the correct one. The I/O cable supplied with the SIM or IMM permits connection to standard 9-pin RS-232 interfaces.

Cause/Solution 4: The modem core in the MicroCAT (and/or the ICC, if applicable) may have a gap, be misaligned, or be damaged. See *Application Note 85: Handling of Ferrite Core in Instruments with Inductive Modem Telemetry* for details on inspecting the modem core and proper installation of the MicroCAT and the ICC (if applicable) on the cable.

Problem 2: No Data Recorded

Cause/Solution 1: The memory may be full; once the memory is full, no further data will be recorded. Verify that the memory is not full using `#iiGetSD` or `#iiDS` (*free = 0* or *1* if memory is full). Sea-Bird recommends that you upload all previous data before beginning another deployment. Once the data is uploaded, send `#iiInitLogging` to reset the memory. After the memory is reset, `#iiGetSD` or `#iiDS` will show *samplenum* = *0*.

Problem 3: Unreasonable T, C, or P Data

The symptom of this problem is a data file that contains unreasonable values (for example, values that are outside the expected range of the data).

Cause/Solution 1: A data file with unreasonable (i.e., out of the expected range) values for temperature, conductivity, or pressure may be caused by incorrect calibration coefficients in the MicroCAT. Send `#iGetCC` or `#iDC` to verify the calibration coefficients in the MicroCAT match the instrument Calibration Certificates. Note that calibration coefficients do not affect the raw data stored in MicroCAT memory or the raw data in the uploaded .hex file.

- If you have not yet overwritten the memory with new data, you can correct the coefficients and then upload the data again.
- If you have overwritten the memory with new data, you can manually correct the coefficients in the .xmlcon configuration file, and then reprocess the data in SBE Data Processing's Data Conversion module.

Problem 4: Salinity Spikes

Salinity is a function of conductivity, temperature, and pressure, and must be calculated from C, T, and P measurements made on the same parcel of water. Salinity can be calculated in SBE Data Processing's Data Conversion module from the data uploaded from memory (.hex file) or in SBE Data Processing's Derive module from the converted (.cnv) file.

[*Background information:* Salinity spikes in **profiling** (i.e., moving, fast sampling) instruments typically result from misalignment of the temperature and conductivity measurements in conditions with sharp gradients. This misalignment is often caused by differences in response times for the temperature and conductivity sensors, and can be corrected for in post-processing if the T and C response times are known.]

In **moored**, free-flushing instruments such as the 37-IM MicroCAT, wave action, mooring motion, and currents flush the conductivity cell at a faster rate than the environment changes, so the T and C measurements stay closely synchronized with the environment (i.e., even slow or varying response times are not significant factors in the salinity calculation). More typical causes of salinity spikes in a moored 37-IM include:

Cause/Solution 1: Severe external bio-fouling can restrict flow through the conductivity cell to such an extent that the conductivity measurement is significantly delayed from the temperature measurement.

Cause/Solution 2: For a MicroCAT moored at shallow depth, differential solar heating can cause the actual temperature inside the conductivity cell to differ from the temperature measured by the thermistor. Salinity spikes associated mainly with daytime measurements during sunny conditions may be caused by this phenomenon.

Cause/Solution 3: For a MicroCAT moored at shallow depth, air bubbles from breaking waves or spontaneous formation in supersaturated conditions can cause the conductivity cell to read low or correct.

Glossary

Note:

The 37-IM battery pack has a **red** cover plate. Some MicroCATs use a battery pack with a yellow cover plate; the wiring of that pack is different from this one, and cannot be used with this MicroCAT.

Note:

All Sea-Bird software listed was designed to work with a computer running Windows XP service pack 2 or later, Windows Vista, or Windows 7.

Note:

IDO MicroCATs are integrated with SBE 43F DO sensors (Clark polarographic membrane type).
ODO MicroCATs are integrated with SBE 63 Optical DO sensors.

Battery pack – 12 AA lithium cells in a battery holder that connects 2 cells in series and each series string in parallel. Battery pack uses:

- Saft LS 14500, AA, 3.6 V and 2.45 Amp-hours each (www.saftbatteries.com) (**recommended**),
- Tadiran TL-4903, AA, 3.6 V and 2.4 Amp-hours each (www.tadiran.com), or
- Electrochem 3B0064/BCX85, AA, 3.9 V and 2.0 Amp-hours each (www.electrochemsolutions.com)

Deployment Endurance Calculator – Sea-Bird’s Windows software used to calculate deployment length for moored instruments, based on user-input deployment scheme, instrument power requirements, and battery capacity.

Fouling – Biological growth in the conductivity cell during deployment.

ICC – Inductive Cable Coupler, which clamps to the insulated mooring cable and transfers the inductive signal on the wire to the SIM PCB or IMM installed inside the buoy or elsewhere.

IMM – Inductive Modem Module PCB, used to interface between the computer serial port and 37-IMs or other compatible IM instruments. Either an IMM or SIM is required to interface with the 37-IM.

MicroCAT (SBE 37) – High-accuracy conductivity, temperature, and optional pressure Recorder/Sensor. A number of models are available:

- 37-IM (Inductive Modem, internal battery pack and memory)
- 37-IMP (Inductive Modem, internal battery pack and memory, integral Pump)
- 37-IMP-IDO (Inductive Modem, internal battery pack and memory, integral Pump, Integrated Dissolved Oxygen sensor) – includes internal RS-232 interface
- 37-IMP-ODO (Inductive Modem, internal battery pack and memory, integral Pump, Optical Dissolved Oxygen sensor) – includes internal RS-232 interface
- 37-SM (Serial interface, internal battery pack and Memory)
- 37-SMP (Serial interface, internal battery pack and Memory, integral Pump)
- 37-SMP-IDO (Serial interface, internal battery pack and Memory, integral Pump, Integrated Dissolved Oxygen sensor)
- 37-SMP-ODO (Serial interface, internal battery pack and Memory, integral Pump, Optical Dissolved Oxygen sensor)
- 37-SI (Serial Interface, memory, no internal battery pack) *
- 37-SIP (Serial Interface, integral Pump, memory, no internal battery pack) *
- 37-SIP-IDO (Serial Interface, integral Pump, Integrated Dissolved Oxygen sensor, memory, no internal battery pack)
- 37-SIP-ODO (Serial Interface, integral Pump, Optical Dissolved Oxygen sensor, memory, no internal battery pack)

The serial interface versions are available with RS-232 or RS-485 interface. Some serial interface versions are also available with an SDI-12 interface.

* Note: Version 3.0 and later of the 37-SI and 37-SIP include memory; earlier versions did not include memory.

PCB – Printed Circuit Board.

SBE Data Processing - Windows data processing software, which calculates and plots temperature, conductivity, and optional pressure, and derives variables such as salinity and sound velocity.

Scan – One data sample containing temperature, conductivity, optional pressure, and date and time.

Seasoft V2– Sea-Bird’s complete Windows software package, which includes software for communication, real-time data acquisition, and data analysis and display. Seasoft V2 includes ***Deployment Endurance Calculator***, ***SeatermV2***, and ***SBE Data Processing***.

SeatermV2 – Windows terminal program *launcher*, which launches the appropriate terminal program for the selected instrument (SeatermIM for this MicroCAT).

SeatermIM – Windows terminal program used with Sea-Bird instruments that communicate via an Inductive Modem (IM) interface, and that were developed or redesigned in 2006 and later. The common feature of these instruments is the ability to output data in XML. Instruments currently supported by SeatermIM include: SBE 16*plus*-IM V2 (version 2 or later digital firmware), 37-IM/ IMP (version 3 or later digital firmware), and 37-IMP-IDO.

Seaterm232 – Windows terminal program used with Sea-Bird instruments that communicate via an RS-232 interface, and that were developed or redesigned in 2006 and later. The common feature of these instruments is the ability to output data in XML. **Use Seaterm232 (by selecting *SBE 37 RS232* in SeatermV2) when communicating with the SBE 37-IM via its internal RS-232 connector.**

SIM – Surface Inductive Modem PCB, used to interface between the computer serial port and 37-IMs or other compatible IM instruments. Either a SIM or IMM is required to interface with the 37-IM.

Super O-Lube – Silicone lubricant used to lubricate O-rings and O-ring mating surfaces. Super O-Lube can be ordered from Sea-Bird, but should also be available locally from distributors. Super O-Lube is manufactured by Parker Hannifin (www.parker.com/ead/cm2.asp?cmid=3956).

TCXO – Temperature Compensated Crystal Oscillator.

Triton X-100 – Reagent grade non-ionic surfactant (detergent), used for cleaning the conductivity cell. Triton can be ordered from Sea-Bird, but should also be available locally from chemical supply or laboratory products companies. Triton is manufactured by Avantor Performance Materials (www.avantormaterials.com/commerce/product.aspx?id=2147509608).

Appendix I: Functional Description

Sensors

The MicroCAT embodies the same sensor elements (3-electrode, 2-terminal, borosilicate glass cell, and pressure-protected thermistor) previously employed in our modular SBE 3 and SBE 4 sensors and in the Seacat and Seacat *plus* family.

Note:

Pressure ranges are expressed in meters of deployment depth capability.

The MicroCAT's optional strain-gauge pressure sensor is available in the following pressure ranges: 20, 100, 350, 600, 1000, 2000, 3500, and 7000 meters. Compensation of the temperature influence on pressure offset and scale is performed by the MicroCAT's CPU.

Sensor Interface

Temperature is acquired by applying an AC excitation to a hermetically sealed VISHAY reference resistor and an ultra-stable aged thermistor with a drift rate of less than 0.002°C per year. A 24-bit A/D converter digitizes the outputs of the reference resistor and thermistor (and optional pressure sensor).

AC excitation and ratiometric comparison using a common processing channel avoids errors caused by parasitic thermocouples, offset voltages, leakage currents, and reference errors.

Conductivity is acquired using an ultra-precision Wien Bridge oscillator to generate a frequency output in response to changes in conductivity.

Real-Time Clock

To minimize power and improve clock accuracy, a temperature-compensated crystal oscillator (TCXO) is used as the real-time-clock frequency source. The TCXO is accurate to ± 1 minute per year (0 °C to 40 °C).

Appendix II: Electronics Disassembly/Reassembly

Disassembly:

CAUTION:

See *Section 5: Routine Maintenance and Calibration* for handling instructions for the plastic *ShallowCAT* housing.

1. Remove the modem end cap and battery pack following instructions in *Installing Batteries* in *Section 3: Preparing MicroCAT for Deployment*.
Do not remove the titanium guard!
2. The electronics are on a sandwich of three rectangular PCBs. These PCBs are assembled to a bulkhead that can be seen at the bottom of the battery compartment. To remove the PCB assembly:
 - A. Use a long screwdriver (#1 screwdriver) to remove the Phillips-head screw at the bottom of the battery compartment. The Phillips-head screw is a 198mm (7.8 inch) threaded rod with Phillips-head.
 - B. Pull out the PCB assembly using the PVC pylon post (post with 3-pin Molex connector). The assembly will pull away from the 10-position edge connector used to connect to the sensors.

Reassembly:

Note:

If the rod will not tighten, the PCBs are not fully mated or are mated in reverse.

1. Sight down into the MicroCAT housing to find the hole into which the Phillips-head screw threads. The hole is at the bottom of the housing, next to the edge connector. The small-diameter brass sleeve between two of the PCBs guides the screw into the hole. Align this sleeve with the hole.
2. Guide the PCB assembly into the housing and push the assembly until the edge connector is fully inserted. A gentle resistance can be felt during the last 3 mm ($1/8$ inch) of insertion as the PCB assembly mates to the edge connector.
3. Drop the Phillips-head screw into the hole and tighten gently.
4. If it is difficult to align the cards, obtain a 305mm (12 in.) length of 6-32 threaded rod.
 - A. Thread the end of this rod into the hole at the bottom of the housing (next to the edge connector).
 - B. Slide the PCB assembly's small diameter brass sleeve down the rod. The rod will help guide the assembly into the proper position.
 - C. Push the assembly until the edge connector is fully inserted. After the PCB assembly has been fully inserted, remove the rod.
 - D. Drop the Phillips-head screw into the hole and tighten gently.
5. Reinstall the battery pack and modem end cap following instructions in *Installing Batteries* in *Section 3: Preparing MicroCAT for Deployment*.

Note:

Sea-Bird inserts a desiccant package is inserted in the housing and fills the electronics chamber with dry Argon gas to help prevent condensation. To ensure proper functioning:

1. Install a new desiccant bag if you open the electronics chamber. If a new bag is not available, see *Application Note 71: Desiccant Use and Regeneration (drying)*.
 2. If possible, dry gas backfill if you open the housing. If you cannot, wait at least 24 hours before redeploying, to allow the desiccant to remove any moisture from the housing.
- Note that opening the battery compartment does not affect desiccation of the electronics.

Appendix III: Command Summary

Note:

- See *Command Descriptions* in *Section 4: Deploying and Operating MicroCAT* for detailed information and examples.
- If using the MicroCAT with an IMM, see the IMM manual for IMM command descriptions.

FUNCTION	CATEGORY	COMMAND	DESCRIPTION
SIM Commands	Power-On	PwrOn	Send wakeup tone to all MicroCATs.
		PwrOff	Send power off command to all MicroCATs. MicroCATs enter quiescent (sleep) state. Main power turned off, but logging and memory retention unaffected.
		AutoPwrOn=x	x=Y (default): Automatically send PwrOn to MicroCATs when power applied to SIM. This wakes up all MicroCATs on line. x=N : Do not send PwrOn when power applied to SIM.
	Status	DS	Display SIM status.
	Communications	Baud=x	x = baud rate between SIM and computer/controller (1200, 2400, 4800, or 9600). Default 9600.
		DataNNMax=x	x = timeout (milliseconds) that applies to Dataii or !iiData only. If no reply received within x (0-32767), control returned to computer and other commands can be sent. Default 1000 milliseconds.
		RelayMax=x	x = timeout (seconds) that applies to all other commands. If no reply received within x (0-3276), control returned to computer and other commands can be sent. Default 20 seconds.
		EchoOn	Echo characters received from computer (default).
		EchoOff	Do not echo characters received from computer.
	MicroCAT Communication Microcontroller Commands	Global	DateTime=mmddyyyyhhmmss
ResumeLogging			Simultaneously command all MicroCATs to start logging.
GData			Command all MicroCAT communication microcontrollers to get average data from acquisition units and (re)start logging and start next averaging cycle. Communication microcontrollers hold averaged data in a buffer until receiving Dataii or !iiData .
StayOn			Command all MicroCATs to reset counting for 2-minute timeout.
Get data		!iiData or Dataii	Get averaged data obtained with GData from MicroCAT with ID=ii.
MicroCAT ID		ID?	Get MicroCAT ID (0-99).
		*ID=ii (only 1 MicroCAT can be on line or all MicroCATs will have same ID)	Set MicroCAT ID to ii (0-99). *ID=ii must be sent twice, because verification requested.
Status		!iiGetHD	Get and display communication microcontroller hardware data.
		!iiDS	Display communication microcontroller status data.

FUNCTION	CATEGORY	COMMAND	DESCRIPTION
MicroCAT Acquisition Microcontroller Commands (ii = MicroCAT ID)	Status	#iiGetCD	Get and display configuration data.
		#iiGetSD	Get and display status data.
		#iiGetCC	Get and display calibration coefficients.
		#iiGetEC	Get and display event counter data.
		#iiResetEC	Reset event counter.
		#iiGetHD	Get and display hardware data.
		#iiDS	Get and display status and configuration data.
		#iiDC	Get and display calibration coefficients.
	General Setup	#iiDateTime= mmddyyyyhhmmss	Set real-time clock month, day, year, hour, minute, second.
		#iiBaudRate=x	x= baud rate (600, 1200, 2400, 4800, 9600, 19200, 38400, 57600, or 115200) for communicating through MicroCAT's internal RS-232 connector. This command must be sent while communicating with IM telemetry; it cannot be sent while communicating via RS-232.
		#iiOutputExecutedTag=x	x=Y: Display XML Executing and Executed tags. x=N: Do not.
		#iiReferencePressure=x	x= reference pressure (gauge) in decibars (used for conductivity calculation when MicroCAT does not have pressure sensor).
		QS	For use only when communicating through internal RS-232 serial connector. Place MicroCAT in quiescent (sleep) state. Main power is turned off. Data logging and memory retention are not affected.
	Memory Setup	#iiInitLogging	Initialize logging to make entire memory available for recording.
		#iiSampleNumber=x	x= sample number for last sample in memory. #iiSampleNumber=0 equivalent to #iiInitLogging .
	Output Format Setup	#iiOutputFormat=x	x=0: output converted hex data. x=1: output converted decimal data x=2: output converted decimal data, alternate format. x=3: output raw decimal data. x=4: output converted decimal data in XML.
		#iiCompatibleMode= x	x=Y: Output data in format compatible with 37-IM/IMP with firmware < 3.0. x=N: Do not output data in compatible mode.
		#iiTxHexTime=x	If #iiOutputFormat=0 : x=Y: Output date/time with hex data. x=N: Do not output date/time with hex data.
		#iiTxSampleNum=x	x=Y: Output six-character sample number with data from Dataii , !iiData , #iiTS , #iiSLT , #iiTSS , #iiTSN:x , #iiSL , #iiSLT , #iiSACG , or #iiSAC . x=N: Do not output sample number.

FUNCTION	CATEGORY	COMMAND	DESCRIPTION	
Continued . . . Acquisition Microcontroller Commands (ii = MicroCAT ID)	Autonomous Sampling (Logging)	#iiSampleInterval=x	x= interval (seconds) between samples (6 – 21,600). When commanded to start sampling with #iiStartNow , #iiStartLater , #iiGA , GData , or ResumeLogging , MicroCAT takes sample, stores data in FLASH memory, and powers down at x second intervals.	
		#iiStartNow	Start logging now.	
		#iiStartDateTime=mmddyyyymmss	Delayed logging start: month, day, year, hour, minute, second.	
		#iiStartLater	Start logging at delayed logging start time.	
		#iiStop	Stop logging or stop waiting to start logging. Must send #iiStop before uploading data.	
		#iiGA	Start logging now	
		#iiSACG	Output averaged data, in format specified by #iiOutputFormat= . Start new average.	
#iiSARG		Output averaged raw data. Start new average.		
#iiSAC		Output averaged data, in format specified by #iiOutputFormat= . Continue averaging.		
#iiSAR		Output averaged raw data. Continue averaging.		
#iiSS		Output statistics. Continue averaging.		
Continued . . . Acquisition Microcontroller Commands (ii = MicroCAT ID)		Polled Sampling (data not stored in FLASH memory, except as noted)	#iiTS	Take sample and output data in format specified by #iiOutputFormat= .
			#iiTSR	Take sample and output data in raw decimal format.
	#iiTSH		Take sample (do not output data).	
	#iiTSS		Take sample, store data in FLASH memory , and output data in format specified by #iiOutputFormat= .	
	#iiTSN:x		Take x samples and output data in format specified by #iiOutputFormat= .	
	#iiSL		Output data from last sample, in format specified by #iiOutputFormat= .	
	#iiSLT		Output data from last sample in format specified by #iiOutputFormat= , and then take new sample (do not output data from new sample).	
	#iiSLTR		Output data from last sample in raw decimal format from last sample, and than take new sample (do not output data from new sample).	
	#iiDNx		Upload last x scans from FLASH memory, in format specified by #iiOutputFormat= .	
	Data Upload (send #iiStop before sending upload command)		#iiGetSamples:b,e	Upload scan b to scan e , in format defined by #iiOutputFormat= .
#iiDDb,e		Upload data from scan b to scan e , in alternate converted decimal format (#iiOutputFormat=2).		

Note:
Use SeatermIM's or Seterm232's Upload menu to upload data that will be processed by SBE Data Processing.
 Manually entering a data upload command does not produce data with the required header information for processing by SBE Data Processing.

FUNCTION	CATEGORY	COMMAND	DESCRIPTION
Continued . . . Acquisition Microcontroller Commands (ii = MicroCAT ID)	Coefficients (F=floating point number; S=string with no spaces) Calibration coefficients are initially factory- set and should agree with Calibration Certificates shipped with MicroCATs. View all coefficients with #iiGetCC or #iiDC .	#iiTCalDate=S	S=Temperature calibration date.
		#iiTA0=F	F=Temperature A0.
		#iiTA1=F	F=Temperature A1.
		#iiTA2=F	F=Temperature A2.
		#iiTA3=F	F=Temperature A3.
		#iiCCalDate=S	S=Conductivity calibration date.
		#iiCG=F	F=Conductivity G.
		#iiCH=F	F=Conductivity H.
		#iiCI=F	F=Conductivity I.
		#iiCJ=F	F=Conductivity J.
		#iiWBOTC=F	F=Conductivity wbotc.
		#iiCTCor=F	F=Conductivity etcor.
		#iiCPCor=F	F=Conductivity epcor.
		#iiPCalDate=S	S=Pressure calibration date.
		#iiPA0=F	F=Pressure A0.
		#iiPA1=F	F=Pressure A1.
		#iiPA2=F	F=Pressure A2.
		#iiPTCA0=F	F=Pressure ptca0.
		#iiPTCA1=F	F=Pressure ptca1.
		#iiPTCA2=F	F=Pressure ptca2.
		#iiPTCB0=F	F=Pressure ptcb0.
		#iiPTCB1=F	F=Pressure ptcb1.
		#iiPTCB2=F	F=Pressure ptcb2.
#iiPTempA0=F	F=Pressure temperature a0.		
#iiPTempA1=F	F=Pressure temperature a1.		
#iiPTempA2=F	F=Pressure temperature a2.		
#iiPOffset=F	F=Pressure offset (decibars).		

Appendix IV: SIM Hookup and Configuration

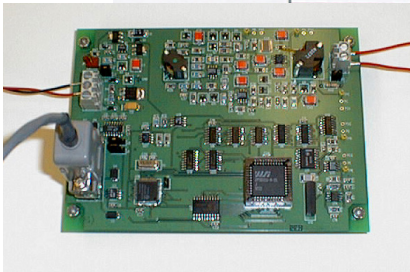
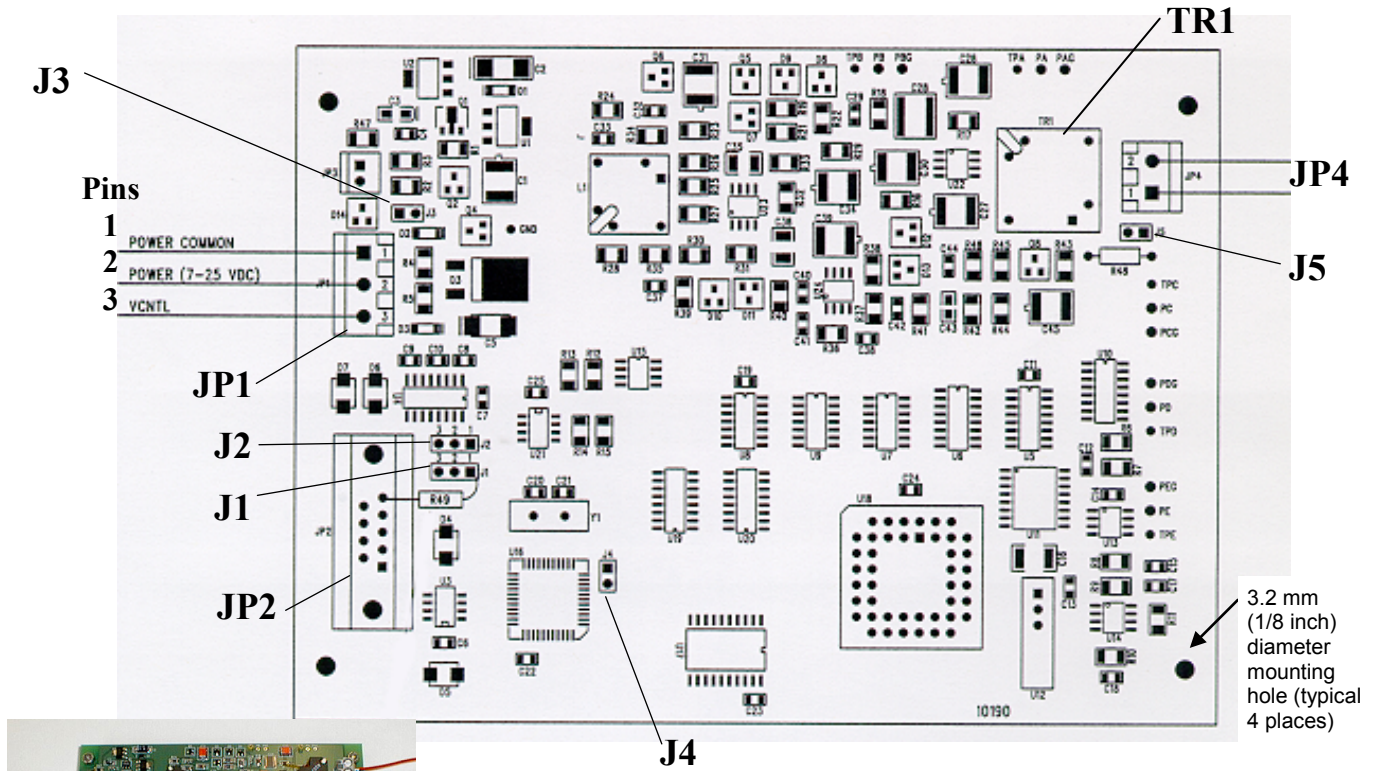

Photo shows SIM-Direct for use without Inductive Cable Coupler. SIM-Coupled for use with Inductive Cable Coupler is similar, but does not include TR1.

Dimensions:

PCB: 109 mm x 147.5 mm (4 1/4 x 5 3/4 inches)

Mounting holes: 90.5 mm x 138.1 mm (3 9/16 x 5 7/16 inches)

Power Connection

The SIM can be configured to power up in either of the following two modes:

- **Normal Power Switching (factory setting)** – The SIM runs when power is applied. Set up the SIM as follows:
 1. Connect Power Common to JP1 pin 1.
 2. Connect 7-25 VDC to JP1 pin 2.
 3. Verify there is no connection to JP1 pin 3.
 4. Verify jumper is across J3.
- **Logic Level Controlled Power Switching** – Power is always applied to JP1, pins 1 and 2. Voltage applied to JP1 pin 3 (VCNTL) switches power to the SIM. Set up the SIM as follows:
 1. Connect Power Common to JP1 pin 1.
 2. Connect 7-25 VDC to JP1 pin 2.
 3. Remove jumper on J3.

Note:
 If VCNTL < 1 volt, SIM is Off (consuming < 100 microAmps).
 If VCNTL > 2 volts, SIM is On.

Interface Option Connection (J1, J2, and J4) and I/O Connector Wiring (JP2)

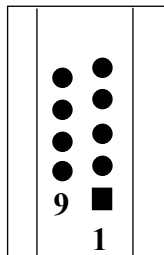
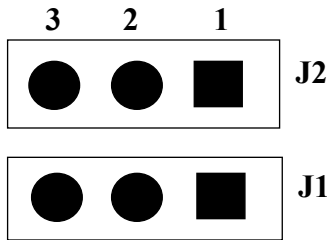

The SIM can be configured to accept RS-232 or RS-485:

- **RS-232 (factory setting)**
 1. Verify jumper is on **J1** pins 2 and 3.
 2. Verify jumper is on **J2** pins 2 and 3.
 3. Remove jumper on **J4**.
- **RS-485**
 1. Install jumper on **J1** pins 1 and 2.
 2. Install jumper on **J2** pins 1 and 2.
 3. Install jumper on **J4**.

Connect wires to **JP2** as follows:

- **RS-232**
 1. **Pin 2** – RS-232 transmit from SIM to computer
 2. **Pin 3** – RS-232 transmit from computer to SIM
 3. **Pin 5** – Power Common
- **RS-485**
 1. **Pin 4** – RS-485 ‘A’
 2. **Pin 5** – Power Common
 3. **Pin 6** – RS-485 ‘B’

Notes on RS-485 Interface

- This implementation of RS-485 allows for extended cable lengths, but does not include the ability to address multiple SIMs online. The RS-485 interface is described as *Simple*, because it does not allow you to communicate with more than one SIM on a single line.
- The RS-485 interface is half-duplex. Do not type or send a command while the SIM is transmitting data or responding to a command, or you will disrupt both sent and received data.
- This SIM can transmit data at 38400 baud over up to 1200 meters of twisted pair wire cable, 26 AWG or smaller gauge (larger diameter); data transmission at long distances is highly application specific, and requires high-quality cable and appropriate termination.

Inductive Mooring Cable Connection (JP4)

Note:

ICC version 4 may have 3 wires in the cable. If you ordered the ICC with a pigtail termination, solder the white and white/black wires together and attach to 1 terminal of JP4. Attach the white/red wire to the other terminal.

- **MicroCAT installed with Inductive Cable Coupler (ICC) -**
Connect wires from the ICC to JP4 on SIM-Coupled.
- **MicroCAT installed without Inductive Cable Coupler -**
Connect wires from the mooring cable and seawater ground to JP4 on SIM-Direct.

Normal Deployed Operation (J5)

Note:

If more than one IM instrument is on-line when you set the ID, all IM instruments will be set to the same ID. The inductive modem receivers in IM instruments are very sensitive; two IM instruments that are side-by-side will take the same ID, even if one of them is not on the IM loop. **Therefore, separate IM instruments by at least 2 meters when setting IDs.**

- **Normal Deployed Operation** – Ensure jumper on J5 is installed.
- **Instrument Setup and Lab Testing** - Remove jumper on J5. Removing the jumper on J5 inserts a 1K resistor in series with the inductive loop, reducing the signal amplitude. This prevents the MicroCATs in close proximity from responding to commands, which is especially important when sending ***ID=**.

Appendix V: *Old-Style* Compatible Commands

To assist customers who have SBE 37-IM MicroCATs with digital firmware less than 3.0 as well as the newer MicroCATs documented in this manual, Sea-Bird retained the following commands in the new firmware. You can use these commands as an alternative to the equivalent commands documented in *Section 4: Deploying and Operating MicroCAT*.

MicroCAT Communication Microcontroller Commands

Notes:

- **DDMMYY=** and **MMDDYY=** are equivalent. Either can be used to set the date.
- **Always set date and then time.** If a new date is entered but not a new time, the new date will not be saved. If a new time is entered without first entering a new date, the date will reset to the last date it was set for with **MMDDYY=** or **DDMMYY=**.

MMDDYY=mmddy

Set real-time clock month, day, year for **all** MicroCATs. Must be followed by **HHMMSS=** to set time.

DDMMYY=ddmmyy

Set real-time clock day, month, year for **all** MicroCATs. Must be followed by **HHMMSS=** to set time.

HHMMSS=hhmmss

Set real-time clock hour, minute, second for **all** MicroCATs.

MicroCAT Acquisition Microcontroller Commands

Notes:

- **#iiDDMMYY=** and **#iiMMDDYY=** are equivalent. Either can be used to set the date.
- **Always set date and then time.** If a new date is entered but not a new time, the new date will not be saved. If a new time is entered without first entering a new date, the date will reset to the last date it was set for with **#iiMMDDYY=** or **#iiDDMMYY=**.

#iiMMDDYY=mmddy

Set real-time clock month, day, year. Must be followed by **#iiHHMMSS=** command to set time.

#iiDDMMYY=ddmmyy

Set real-time clock day, month, year. Must be followed by **#iiHHMMSS=** command to set time.

#iiHHMMSS=hhmmss

Set real-time clock hour, minute, second.

Example: Set current date and time for MicroCAT 03 to 10 January 2012 12:00:00 (user input in bold).

#03MMDDYY=011012

#03HHMMSS=120000

or

#03DDMMYY=100112

#03HHMMSS=120000

#iiFormat=x

x=1 (default): Output converted data. date format dd mmm yyyy, conductivity =S/m, temperature precedes conductivity

x=2: Output converted data. date format dd-mm-yyyy, conductivity=mS/cm, conductivity precedes temperature.

Note: This date format does not match older format. See *Note* at left.

Note:

If **#iiCompatibleMode=Y** and **#iiFormat=2**, date is output as mm-dd-yyyy instead of dd-mm-yyyy. This provides output compatible with systems programmed for 37-IM/IMPs with digital firmware < 3.0.

#iiRefPress=x	x = reference pressure (gauge) in decibars. MicroCAT without installed pressure sensor uses this reference pressure in conductivity calculation. Entry ignored if MicroCAT includes pressure sensor.
#iiPumpInstalled=x	x =Y: Not valid setting for 37-IM. x=N: Internal pump not installed (only valid setting for 37-IM).
#iiInterval=x	x= interval (6 – 21,600 seconds) between samples. When commanded to start sampling (with #iiStartNow , #iiStartLater , GData , or ResumeLogging), MicroCAT takes a sample, stores data in FLASH memory, and powers down at x second intervals.
#iiSampleNum=x	x= sample number for first sample when logging. After all previous data has been uploaded from MicroCAT, set sample number to 0 before starting to log to make entire memory available for recording. If #iiSampleNum is not reset to 0, data will be stored after last recorded sample.
#iiStartMMDDYY=mmddy	Set delayed logging start month, day, year. Must be followed by #iiStartHHMMSS= to set delayed start time.
#iiStartDDMMYY=ddmmy	Set delayed logging start day, month, year. Must be followed by #iiStartHHMMSS= to set delayed start time.
#iiStartHHMMSS=hhmss	Set delayed logging start hour, minute, second.

Note:

#iiStartDDMMYY= and **#iiStartMMDDYY=** are equivalent. Either can be used to set the delayed start date.

Example: Program MicroCAT 03 to start logging on 20 July 2012 12:00:00 (user input in bold).

```
#03STARTMMDDYY=072012
#03STARTEHHMMSS=120000
#03STARTLATER
```

or

```
#03STARTDDMMYY=200712
#03STARTEHHMMSS=120000
#03STARTLATER
```

#iiTSSTx	Take sample, store in FLASH memory , and transmit converted data. If MicroCAT is logging or waiting to log when #iiTSSTx is sent, MicroCAT executes #iiTS instead.
-----------------	---

Appendix VI: AF24173 Anti-Foulant Device

AF24173 Anti-Foulant Devices supplied for user replacement are supplied in polyethylene bags displaying the following label:

AF24173 ANTI-FOULANT DEVICE	
FOR USE ONLY IN SEA-BIRD ELECTRONICS' CONDUCTIVITY SENSORS TO CONTROL THE GROWTH OF AQUATIC ORGANISMS WITHIN ELECTRONIC CONDUCTIVITY SENSORS.	
ACTIVE INGREDIENT:	
Bis(tributyltin) oxide.....	53.0%
OTHER INGREDIENTS:	<u>47.0%</u>
Total.....	100.0%
DANGER	
See the complete label within the Conductivity Instrument Manual for Additional Precautionary Statements and Information on the Handling, Storage, and Disposal of this Product.	
Net Contents: Two anti-foulant devices	
Sea-Bird Electronics, Inc. 13431 NE 20 th Street Bellevue, WA 98005	EPA Registration No. 74489-1 EPA Establishment No. 74489-WA-1

AF24173 Anti-Foulant Device

FOR USE ONLY IN SEA-BIRD ELECTRONICS' CONDUCTIVITY SENSORS TO CONTROL THE GROWTH OF AQUATIC ORGANISMS WITHIN ELECTRONIC CONDUCTIVITY SENSORS.

ACTIVE INGREDIENT:

Bis(tributyltin) oxide.....	53.0%
OTHER INGREDIENTS:	47.0%
Total.....	100.0%

DANGER

See Precautionary Statements for additional information.

FIRST AID	
If on skin or clothing	<ul style="list-style-type: none"> • Take off contaminated clothing. • Rinse skin immediately with plenty of water for 15-20 minutes. • Call a poison control center or doctor for treatment advice.
If swallowed	<ul style="list-style-type: none"> • Call poison control center or doctor immediately for treatment advice. • Have person drink several glasses of water. • Do not induce vomiting. • Do not give anything by mouth to an unconscious person.
If in eyes	<ul style="list-style-type: none"> • Hold eye open and rinse slowly and gently with water for 15-20 minutes. • Remove contact lenses, if present, after the first 5 minutes, then continue rinsing eye. • Call a poison control center or doctor for treatment advice.
HOT LINE NUMBER	
Note to Physician	Probable mucosal damage may contraindicate the use of gastric lavage.
Have the product container or label with you when calling a poison control center or doctor, or going for treatment. For further information call National Pesticide Telecommunications Network (NPTN) at 1-800-858-7378.	

Net Contents: Two anti-foulant devices

Sea-Bird Electronics, Inc.
13431 NE 20th Street
Bellevue, WA 98005

EPA Registration No. 74489-1
EPA Establishment No. 74489-WA-1

PRECAUTIONARY STATEMENTS

HAZARD TO HUMANS AND DOMESTIC ANIMALS

DANGER

Corrosive - Causes irreversible eye damage and skin burns. Harmful if swallowed. Harmful if absorbed through the skin or inhaled. Prolonged or frequently repeated contact may cause allergic reactions in some individuals. Wash thoroughly with soap and water after handling.

PERSONAL PROTECTIVE EQUIPMENT

USER SAFETY RECOMMENDATIONS

Users should:

- Remove clothing immediately if pesticide gets inside. Then wash thoroughly and put on clean clothing.
- Wear protective gloves (rubber or latex), goggles or other eye protection, and clothing to minimize contact.
- Follow manufacturer's instructions for cleaning and maintaining PPE. If no such instructions for washables, use detergent and hot water. Keep and wash PPE separately from other laundry.
- Wash hands with soap and water before eating, drinking, chewing gum, using tobacco or using the toilet.

ENVIRONMENTAL HAZARDS

Do not discharge effluent containing this product into lakes, streams, ponds, estuaries, oceans, or other waters unless in accordance with the requirements of a National Pollutant Discharge Elimination System (NPDES) permit and the permitting authority has been notified in writing prior to discharge. Do not discharge effluent containing this product to sewer systems without previously notifying the local sewage treatment plant authority. For guidance contact your State Water Board or Regional Office of EPA. This material is toxic to fish. Do not contaminate water when cleaning equipment or disposing of equipment washwaters.

PHYSICAL OR CHEMICAL HAZARDS

Do not use or store near heat or open flame. Avoid contact with acids and oxidizers.

DIRECTIONS FOR USE

It is a violation of Federal Law to use this product in a manner inconsistent with its labeling. For use only in Sea-Bird Electronics' conductivity sensors. Read installation instructions in the applicable Conductivity Instrument Manual.

STORAGE AND DISPOSAL

PESTICIDE STORAGE: Store in original container in a cool, dry place. Prevent exposure to heat or flame. Do not store near acids or oxidizers. Keep container tightly closed.

PESTICIDE SPILL PROCEDURE: In case of a spill, absorb spills with absorbent material. Put saturated absorbent material to a labeled container for treatment or disposal.

PESTICIDE DISPOSAL: Pesticide that cannot be used according to label instructions must be disposed of according to Federal or approved State procedures under Subtitle C of the Resource Conservation and Recovery Act.

CONTAINER HANDLING: Nonrefillable container. Do not reuse this container for any other purpose. Offer for recycling, if available.

Appendix VII: Replacement Parts

Part Number	Part	Application Description	Quantity in MicroCAT
50441	3.6V AA Saft Lithium cells (12)	Power MicroCAT	1
801797	Cell holder holder for MicroCAT	Holds AA cells. Note: This battery holder has a red cover plate. Some MicroCATs use a battery holder with a yellow cover plate; those packs are wired differently, and will not work properly in this MicroCAT.	1
801542	AF24173 Anti-Foulant Device	Bis(tributyltin) oxide device inserted into anti-foulant device cup	1 (set of 2)
233539	Anti-foulant device cup	Holds AF24173 Anti-Foulant Device	2
233540	Anti-foulant device cap	Secures AF24173 Anti-Foulant Device in cup	2
30984	Plug	Seals end of anti-foulant cap when not deployed, keeping dust and aerosols out of conductivity cell during storage	2
30411	Triton X-100	Octyl Phenol Ethoxylate – Reagent grade non-ionic cleaning solution for conductivity cell (supplied in 100% strength; dilute as directed)	1
50087.1	Conductivity cell filling & storage device with hose barb caps	For cleaning and storing conductivity cell	-
30507	Parker 2-206N674-70 O-ring	Between end of conductivity cell and anti-foulant device cup	2
60050	Spare hardware/ O-ring kit for 37-IM/-IMP with titanium housing	Assorted hardware and O-rings, including: <ul style="list-style-type: none"> • 30544 Machine screw, 8-32 x 1/2, FH, titanium (secures conductivity cell guard to housing) • 30900 Bolt, 1/4-20 x 2" hex head, titanium (secures mounting clamp) • 30633 Washer, 1/4" split ring lock, titanium (for 30900) • 30634 Washer 1/4" flat, titanium (for 30900) • 31019 O-ring Parker 2-008 N674-70 (for 30900) • 30857 Parker 2-033E515-80 O-ring (modem end cap and sensor end cap o-ring) • 30859 Machine screw, 8-32 x 3/8" FH, titanium (secures housing to modem end cap) • 31749 Hex key, 7/64 inch, long arm (secures battery pack in housing with captured screw) • 31322 O-ring Parker 2-130 N674-70 (for grooves on side of battery pack) • 30858 O-ring Parker 2-133 N674-70 (for battery pack cover plate) 	-

Continued on next page

Continued from previous page

Part Number	Part	Application Description	Quantity in MicroCAT
60054	Spare hardware/ O-ring kit for 37-IM with plastic housing	Assorted hardware and O-rings, including: <ul style="list-style-type: none"> • 30544 Machine screw, 8-32 x 1/2", FH, titanium (secures conductivity cell guard to housing) • 30900 Bolt, 1/4-20 x 2" hex head, titanium (secures mount clamp) • 30633 Washer, 1/4" split ring lock, titanium (for 30900) • 30634 Washer, 1/4" flat, titanium (for 30900) • 31019 O-ring Parker 2-008 N674-70 (for 30900) • 30857 O-Ring Parker 2-033E515-80 (modem end cap and sensor end cap o-ring) • 31755 Cap screw, 8-32 X 1/4" SH, titanium (secures housing to modem end cap) • 31516 Hex key, 9/64 inch long arm (for installing 31755) • 31749 Hex key, 7/64 inch, long arm (secures battery pack in housing with captured screw) • 31322 O-ring Parker 2-130 N674-70 (for grooves on side of battery pack) • 30858 O-ring Parker 2-133 N674-70 (for battery pack cover plate) 	-
801836	6-pin DF11 to 9-pin DB-9S I/O cable, 0.3 m (1 ft) long	From internal RS-232 connector to computer, for fast upload and/or for updating firmware (remove battery end cap to connect)	-
171887	9-pin DB-9P to 9-pin DB-9S I/O cable, 3 m (10 ft)	From SIM to computer	-
801583	10-pin DF11 to 9-pin DB-9S and battery snap	From IMM to computer and power supply	-
17188	25-pin DB-25S to 9-pin DB-9P cable adapter	For use with computer with DB-25 connector	-

Appendix VIII: Manual Revision History

Manual Version	Date	Description
005	11/99	<ul style="list-style-type: none"> Change product from potted to modular (take apart) design.
006	09/00	<ul style="list-style-type: none"> Change to Druck pressure sensor. Incorporate Seaterm. Correct pressure port size. Add information about synchronizing logging. Add Echoon & Echooff commands. Changes related to digital firmware version 2.1.
007	01/01	<ul style="list-style-type: none"> Minor update to specifications, consistent with new data sheet. Correct #iiTXSampleNum. Discuss Deployment Pressure dialog box when using Seaterm's Convert. Add references to SBE Data Processing.
008	03/01	<ul style="list-style-type: none"> Add Baud command for SIM.
009	02/02	<ul style="list-style-type: none"> Correct SIM power supply VDC in Test Setup. Update communications current. Add 2000 meter pressure sensor, add miscellaneous explanatory information.
010	12/02	<ul style="list-style-type: none"> Setting time without date resets date to last date set with ddmmyy= or mmddyy=. Correct part number for anti-foul cup. Anti-foul replacement – use EPA-approved description. Add O-ring to Replacement Parts list. Correct pressure sensor calibration fitting. Add pressure port maintenance. Remove information about anti-foulant life. Rewrite description of Convert. Add more information on power endurance calculation.
011	01/03	<ul style="list-style-type: none"> Add AF label information in appendix. Add new commands (global StayOn and ResumeLogging, and #iiDNx) for SIM 2.5, 37-IM modem 1.2 and 37-IM Digital 2.2
012	03/04	<ul style="list-style-type: none"> Changes associated with Seaterm updates. Add SIM mounting hole diameter. Add / revise information on shipping lithium batteries. GData starts logging without needing to send StartNow or StartLater. Update SIM DS reply to reflect new commands in SIM version 2.8a. #iiDS output <i># to be averaged</i> cannot be changed by command, preset by SBE. Reference pressure line in #iiDS reply only if no pressure sensor installed. Mention large toroid and titanium clamp availability.
013	06/04	<ul style="list-style-type: none"> Changes associated with new board layout, modem firmware 1.3, digital firmware 2.3. ICC Version 4. Change SIM terminology to SIM-Direct and SIM-Coupled.
014	12/04	<ul style="list-style-type: none"> Digital firmware 2.3a eliminates requirement to send #iiStop before #iiDNx. Add 600 m pressure sensor. Add more Triton information – strength, where to order, etc. Heat to < 40 C. Add details on processing data in Derive with .con file. Change DataNNMax maximum value to 32767 msec. Previously showed 65535 msec as maximum – number greater than 65485 works properly but displays incorrectly. Add troubleshooting section
015	05/05	<ul style="list-style-type: none"> Update cleaning recommendations to correspond to revised application note 2D. Update AF24173 Anti-Foulant Device appendix to current label. Update battery shipping precautions. Add #iiDNx to list of commands that can be sent while logging. Change SIM operating current from 60 mA to 30 mA based on testing.

Continued on next page

Continued from previous page

016	08/05	<ul style="list-style-type: none"> • Add information about <i>SBE 37-IM Format 0 to ASCII Converter</i>. • Add note to SIM wiring appendix, Inductive Mooring Cable Connection (JP4): For ICC with pigtail termination: In some ICC versions, there are 3 wires. Solder white and white/black wires together, attach to 1 terminal of JP4. Attach white/red wire to other JP4 terminal.
017	05/06	<ul style="list-style-type: none"> • Add more detail to recovery warning.
018	12/06	<ul style="list-style-type: none"> • Add option for plastic housing. • Add more detail on mating of modem core, description of guide, communication problems caused by broken ferrite in ICC or instrument clamp, see application note 85 for details. • Add explanation about NCycles in status (#iiDS) response. • Update Triton website information. • Pressure port maintenance – SBE no longer putting silicon oil in port. • Update PN of AF24173.
019	06/07	<ul style="list-style-type: none"> • Add handling precautions for plastic housing.
020	07/08	<ul style="list-style-type: none"> • Update battery installation procedure, specifications, endurance, & shipping instructions for new battery packs (12 AA lithium cells). • Add information that Poffset is in decibars. • Change stability specification for pressure to per year instead of per month.
021	12/08	<ul style="list-style-type: none"> • Update for new boards and Digital Firmware Version 3.0. • Update for SeatermV2. • Manufacturing change: for plastic housing, 2 Phillips-head screws at battery end cap replaced with hex screws (9/64" Allen wrench shipped with instrument). • Update PN231459 to 233539 (black cup), PN 231505 to 233540 (black cap).
022	08/09	<ul style="list-style-type: none"> • Add information about Deployment Endurance Calculator. • Change Seasoft-Win32 to Seasoft V2, update file name to SeasoftV2_date.exe. • Update SeatermV2 screen capture. • Update SeatermIM Send Commands window screen capture. • Add battery endurance example to cover uploading all data since last query using #iiDNx. • RS-232 upload: remove battery end cap and connect to Molex pins, don't need to connect to PCB. • Update battery pack information in Replacement Parts list.
023	12/09	<ul style="list-style-type: none"> • Digital firmware 3.0c: Add #iiCompatibleMode= to fix firmware bug. If Y, then date & time format for #iiOutputFormat=2 or #iiFormat=2 matches that of firmware < 3.0. Also, output for #iiDNx doesn't have start sample number or start sample time lines. This makes current firmware fully compatible with systems set up for firmware < 3.0. • Remove #iiFormat=0 from list of old compatible commands, not supported. • Add statement about not having other IM instruments nearby when setting ID. • SBE Data Processing 7.20a: Add information about .xmlcon file. • Add CE mark. • Update SBE address. • Update anti-foul label in Appendix with new Container Handling requirement and new address.
024	07/10	<ul style="list-style-type: none"> • Digital firmware 3.0c fix, not documented previously: Fix bug related to #iiStartDateTime=. Previously, when #iiStartLater was sent, register ignored month in #iiStartDateTime=, and started at next day and time corresponding to day and time (example: if it is July 1 and you set it to start on August 15, it ignored the August part of the date, and started on July 15). Manual said could be started 90 days out, but this actually limited it to 30 days out. Now, it provides a message saying it will start logging in 5 seconds if start date is > 30 days out. • Clarify shipping restrictions for spare lithium batteries. • Add 60054 spare parts kit for plastic housing.
025	08/10	<ul style="list-style-type: none"> • Digital firmware 3.0e: add #iiOutputFormat=0 for converted hex data, #iiTxHexTime=0 (do not append date/time with converted hex data) or 1 (append date/time with converted hex data). This gives output as described in appendix III of manual for 37-IM digital firmware 2.3b.
026	10/10	<ul style="list-style-type: none"> • Update for changes to SeatermV2 version 1.1 (upload now converts .xml file to .hex and .xmlcon files, which are used in Data Conversion to convert to .cnv file for further processing). • Remove references to Druck pressure sensors (pressure sensors can be supplied by other manufacturers).

Continued on next page

Continued from previous page

027	03/11	<ul style="list-style-type: none"> • SeatermV2 1.1b changes: <ul style="list-style-type: none"> - Update upload procedure, Seaterm232 now automatically starts SBE Data Processing after upload. - Update SeatermV2 Instruments list screen capture. • Add information about compatibility with Windows 7.
028	08/12	<ul style="list-style-type: none"> • Update Shipping Precautions for latest IATA rules. • Add Declaration of Conformity. • Add more information on selecting output variables for data processing of uploaded data. • Update configuration dialog box in SBE Data Processing. • Triton – update company name (Avantor Performance Materials) and link. • Remove factory-set commands: #iiSetPressureInstalled=, #iiSetMfgDate=, #iiSetPCBAssembly=, #iiSetPCBSerialNum=. • Glossary - Add information on ODO MicroCATs • Add more information on RS-485 version of SIM. • Remove RS-485 option for IMM. • Clarify information on correct battery pack to use with this MicroCAT. • Fix typos.
029	01/13	<ul style="list-style-type: none"> • Update lithium shipping restrictions to meet 2013 requirements. • Update Upload dialog box. • Update software compatibility information. • Add information about limitations with 115200 baud rate.
030	09/13	<ul style="list-style-type: none"> • Update plastic housing depth rating to 350 meters. • Add RS-232 cable wiring drawing. • Update SeatermV2 screen capture, and Upload dialog box. • Clarify that accuracy specifications are \pm. • Glossary - Add information on SDI-12 MicroCATs. • Add information on editing raw .hex files. • Update Declaration of Conformity. • Fix typos.
031	03/14	<ul style="list-style-type: none"> • Update lithium cell and battery language to conform to latest IATA rules. • Update temperature range and accuracy specifications. • Add information on O-ring maintenance. • Remove <i>standard</i> and <i>optional</i> language.

Index

.hex files
editing · 77

A

Acquisition microcontroller · 43
Anti-Foulant Device · 63, 98
 removal before shipping to Sea-Bird · 82
 replacing · 81
Autonomous sampling · 35, 52

B

Battery pack · 11, 62
 endurance · 10, 14, 20
 installing · 18
 replacing · 80
 shipping precautions · 8
Baud command · 50

C

Cables · 13
Calibration · 82
Calibration coefficients · 56
CE certification · 3
Cells
 installing · 18
 replacing · 80
Cleaning · 78
Clock · 11, 88
Combo sampling · 36
Command summary · 90
Commands
 acquisition microcontroller · 43, 96
 autonomous sampling · 52
 baud · 50
 calibration coefficients · 56
 communication microcontroller · 41, 96
 communications · 40, 50
 data format · 51
 data upload · 55
 date and time · 50
 descriptions · 38
 echo · 39
 general setup · 50
 get data · 42
 global · 41
 ID · 42
 logging · 52
 memory setup · 51
 old-style · 96
 output format · 51
 polled sampling · 53
 power-on · 39
 status · 39, 42, 43
 Surface Inductive Modem · 39
 timeout · 39
 upload · 66
Communication defaults · 23, 26, 30, 70
Communication microcontroller · 41
Communications commands · 40, 50
Conductivity cell · 88
 cleaning · 78
Corrosion precautions · 78

D

Data Conversion · 73
Data format · 51, 57
Data processing · 10, 20, 66, 73
Data upload · 55, 66
Date and time · 50
Declaration of Conformity · 3
Deployment · 63
 preparing for · 18
 setup · 62
Deployment Endurance Calculator · 10, 14, 20
Derive · 73
Description · 9
Dimensions · 12

E

Editing data files · 77
Electronics disassembly/reassembly · 89

F

Flooded CTD · 65
Format
 data · 57
Functional description · 88

G

Get data · 42
Global commands · 41
Glossary · 86
Guard
 removal · 81

I

ICC · *See* Inductive Cable Coupler
ID · 26, 30, 42
 setting · 25, 28
IM telemetry · 21
IMM · 28, *See* Inductive Modem Module
Inductive Cable Coupler · 17, 64
Inductive Modem Module · 16, 28
Initializing memory · 51

L

Limited liability statement · 2
Logging · 35, 52

M

Maintenance · 78
Manual revision history · 104
Memory · 11
Memory setup · 51
Modes · *See* Sampling modes
Mooring cable · 17
Mounting · 63

O

Old-style commands · 96
Operation description · 32
O-ring
 maintenance · 80
Output format · 51, 57

P

Parker Super O-Lube · 87
 Parts
 replacement · 102
 Plastic housing
 handling · 79
 Plugs · 63
 Polled sampling · 34, 53
 Power
 endurance · 10, 14, 20
 Power-on commands · 39
 Pressure sensor · 88
 maintenance · 80
 Processing data · 66

Q

Quick start · 6

R

Recovery · 65
 uploading data · 66
 Replacement parts · 102
 Revision history · 104
 RS-232 telemetry · 21, 67
 RS-485 · 95

S

Sample timing · 14
 Sampling modes · 33
 autonomous · 35
 averaging · 37
 combo · 36
 logging · 35
 polled · 34
 SBE Data Processing · 10, 20, 73
 Sea Plot · 73
 Seasoft · 10, 20
 Seaterm232 · 10, 20, 21, 67
 SeatermIM · 10, 20, 21, 26, 30, 70
 SeatermV2 · 10, 20, 21, 26, 30, 66, 70
 Sensors · 11
 Serial mode telemetry · 21, 67
 Setup commands · 50
 ShallowCAT
 handling · 79
 Shipping precautions · 8
 SIM · *See* Surface Inductive Modem
 Software · 10, 20
 Specifications · 11
 Status · 42
 Status commands · 39, 43
 Storage · 78
 Super O-Lube · 87
 Surface Inductive Modem · 16, 25
 RS-485 · 95
 wiring · 94
 System description · 9

T

Terminal program · 10, 20, 21, 26, 30, 66, 70
 Test
 setup · 28
 Testing · 25, 28
 Thermistor · 88
 Timeout descriptions · 33
 Triton · 87
 Troubleshooting · 84

U

Unpacking MicroCAT · 7
 Uploading data · 55, 66
 RS-232 telemetry · 67
 serial mode telemetry · 67

V

Versions · 104

W

Wiring · 13, 64