

SBE 37-SMP-ODO SDI-12 MicroCAT

*Conductivity, Temperature, (optional) Pressure, and
Optical Dissolved Oxygen Recorder with
SDI-12 and RS-232 Interface and Integral Pump*



For most applications, deploy in orientation shown (connector end down) for proper operation

User's Manual

Sea-Bird Electronics, Inc.
13431 NE 20th Street
Bellevue, Washington 98005 USA
Telephone: +1 425-643-9866
Fax: +1 425-643-9954
E-mail: seabird@seabird.com
Website: www.seabird.com

Manual version #005, 03/12/14
Firmware version 2.4.2 and later
SeatermV2 version 2.3.0 and later
SBE Data Processing version 7.23.1 and later



Limited Liability Statement

Extreme care should be exercised when using or servicing this equipment. It should be used or serviced only by personnel with knowledge of and training in the use and maintenance of oceanographic electronic equipment.

SEA-BIRD ELECTRONICS, INC. disclaims all product liability risks arising from the use or servicing of this system. SEA-BIRD ELECTRONICS, INC. has no way of controlling the use of this equipment or of choosing the personnel to operate it, and therefore cannot take steps to comply with laws pertaining to product liability, including laws which impose a duty to warn the user of any dangers involved in operating this equipment. Therefore, acceptance of this system by the customer shall be conclusively deemed to include a covenant by the customer to defend, indemnify, and hold SEA-BIRD ELECTRONICS, INC. harmless from all product liability claims arising from the use or servicing of this system.

Declaration of Conformity

Sea-Bird Electronics, Inc.
13431 NE 20th Street, Bellevue, WA 98005 USA

DECLARATION OF CONFORMITY

Manufacturer's Name: Sea-Bird Electronics
Manufacturer's Address: 13431 NE 20th Street
Bellevue, WA 98005, USA

The Authorized Representative located within the Community is:
OTT MESSTECHNIK GmbH & Co.KG
P.O.Box: 2140 / 87411 Kempten / Germany
Ludwigstrasse 16 / 87437 Kempten
Internet: <http://www.ott.com>
Phone: +49 831 5617 – 100
Fax: +49 831 5617 - 209

Device Description: Various Data Acquisition Devices and Sensors

Model Numbers:

3S	3F	3plus	4C	4M	5T	5P	5M	7
8	9plus	11plus	14	16plus V2	16plus-IM V2		17plus V2	18
19plus V2	21	25plus	26plus	27	29	32	32C	32SC
33	35	35RT	36	37-IMP	37-IM	37-SMP	37-SM	37-SIP
37-SI	38	39	39-IM	39plus	41	41CP	43	43F
44	45	49	50	52-MP	53BPR	54	55	56
63	SIM	ICC	IMM	PDIM	AFM	90488	90204	90402
90504	Glider Payload CTD		NiMH Battery Charger and Battery Pack					

Applicable EU Directives: Machinery Directive 98 / 37 /EC
EMC Directive 2004 / 108 /EC
Low Voltage Directive (73 / 23 /EEC) as amended by (93 / 68 /EEC)

Applicable Harmonized Standards:
EN 61326-1:2006 Class A Electrical Equipment for Measurement, Control, and Laboratory Use, EMC Requirement – Part 1: General Requirements
(EN 55011:2007 Group 1, Class A)

EN 61010-1:2001, Safety Requirements for Electrical Equipments for Measurement, Control, and Laboratory Use – Part 1: General Requirements

Declaration based upon compliance to the Essential Requirements and Letter of Opinion from CKC Certification Services, LLC., Notified Body 0976

I, the undersigned, hereby declare that the equipment specified above conforms to the above European Union Directives and Standards.

Authorized Signature: 
Name: Nordeen Larson
Title of Signatory: President
Date: 3 September 2013
Place: Bellevue, WA

Table of Contents

Limited Liability Statement	2
Declaration of Conformity	3
Table of Contents	4
Section 1: Introduction	6
About this Manual	6
Quick Start	6
Unpacking MicroCAT	7
Shipping Precautions	8
Section 2: Description of MicroCAT	9
System Description	9
Specifications.....	11
Dimensions and End Cap Connector	12
Cables and Wiring	13
Pump Operation	14
Minimum Conductivity Frequency for Pump Turn-On	14
Pumping Time and Speed	14
Sample Timing.....	16
Battery Endurance.....	16
External Power.....	18
Cable Length and External Power	18
Section 3: Preparing MicroCAT for Deployment	20
Battery Installation.....	20
Software Installation	22
Power and Communications Test	22
Test Setup	22
Test	23
Section 4: Deploying and Operating MicroCAT	28
Sampling Modes	28
Polled Sampling.....	29
Autonomous Sampling (Logging commands).....	30
RS-232 Real-Time Data Acquisition	31
Timeout Description	31
Command Descriptions – Transmission via RS-232	32
Command Descriptions and Data Output Format –	
Transmission via SDI-12	53
SDI-12 Standard Commands	53
SDI-12 Extended Commands	55
SDI-12 Data Format	56
RS-232 Data Formats.....	57
Optimizing Data Quality / Deployment Orientation	61
Setup for Deployment.....	62
Deployment.....	63
Recovery	64
Uploading and Processing Data	65
Editing Raw Data File.....	72

Section 5: Routine Maintenance and Calibration	73
Corrosion Precautions	73
Connector Mating and Maintenance	73
Conductivity Cell and Dissolved Oxygen Sensor Maintenance	74
Plumbing Maintenance	74
Handling Instructions for Plastic <i>ShallowCAT</i>	75
Replacing Batteries	76
Pressure Sensor (optional) Maintenance	76
Replacing Anti-Foulant Devices – Mechanical Design Change	77
Replacing Anti-Foulant Devices (SBE 37-SI, SM, IM)	78
Sensor Calibration	79
Section 6: Troubleshooting	81
Problem 1: Unable to Communicate with MicroCAT	81
Problem 2: No Data Recorded	81
Problem 3: Unreasonable T, C, P, or D.O. Data	81
Problem 4: Salinity Spikes	82
Glossary	83
Appendix I: Functional Description	85
Sensors	85
Sensor Interface	85
Real-Time Clock	85
Appendix II: Electronics Disassembly/Reassembly	86
Appendix III: Command Summary	88
Appendix IV: AF24173 Anti-Foulant Device	91
Appendix V: Replacement Parts	95
Appendix VI: Manual Revision History	97
Index	98

Section 1: Introduction

This section includes a Quick Start procedure, photos of a typical MicroCAT shipment, and battery shipping precautions.

About this Manual

This manual is to be used with the SBE 37-SMP-ODO SDI-12 MicroCAT Conductivity, Temperature, and **O**ptical **D**issolved **O**xxygen Recorder (pressure optional) with SDI-12 and RS-232 Serial interfaces, internal **M**emory, and integral **P**ump. It is organized to guide the user from installation through operation and data collection. We've included detailed specifications, command descriptions, maintenance and calibration information, and helpful notes throughout the manual.

Sea-Bird welcomes suggestions for new features and enhancements of our products and/or documentation. Please contact us with any comments or suggestions (seabird@seabird.com or 425-643-9866). Our business hours are Monday through Friday, 0800 to 1700 Pacific Standard Time (1600 to 0100 Universal Time) in winter and 0800 to 1700 Pacific Daylight Time (1500 to 0000 Universal Time) the rest of the year.

Quick Start

Follow these steps to get a Quick Start using the MicroCAT.

The manual provides step-by-step details for performing each task:

1. Install AA lithium cells and test power and communications (*Section 3: Preparing MicroCAT for Deployment*).
2. Deploy the MicroCAT (*Section 4: Deploying and Operating MicroCAT*):
 - A. Install new AA lithium cells if necessary.
 - B. Ensure all data has been uploaded, and then send **InitLogging** to make entire memory available for recording if desired.
 - C. Set date and time, and establish setup and logging parameters.
 - D. Check status (**DS**) and calibration coefficients (**DC**) to verify setup.
 - E. **For SDI-12 deployments:**
 - Set address (**SetAddress=** via RS-232, or aAb! via SDI-12) for SDI-12 communications (0-9, a-z, A-Z).
 - Program controller to send periodic requests to run pump and sample (aM!, aMC!, aC!, or aCC! store data in MicroCAT FLASH memory; aM1!, aMC1!, aC1!, or aCC1! do not store data in FLASH memory), and then transmit sample (aD0!, aD1!).
 - F. **For RS-232 deployments:** If you will be sampling autonomously, use of the following sequences to start logging:
 - **StartNow** to start logging now, sampling every **SampleInterval=** seconds.
 - **StartDateTime=** and **StartLater** to start logging at specified date and time, sampling every **SampleInterval=** seconds.
 - G. Remove yellow protective label from plumbing intake and exhaust. Remove conductivity cell guard, and verify AF24173 Anti-Foulant Devices are installed. Replace conductivity cell guard. Leave label off for deployment.
 - H. Install dummy plug or cable connector, and locking sleeve.
 - I. Deploy MicroCAT, using Sea-Bird or customer-supplied hardware. For **most** applications, mount the MicroCAT with the connector at the bottom for proper operation.
 - J. Upload data from memory.

Unpacking MicroCAT

Shown below is a typical MicroCAT shipment.



SBE 37-SMP-ODO SDI-12
MicroCAT



12 AA lithium cells



I/O cable



Spare hardware
and o-ring kit



Conductivity cell cleaning
solution (Triton-X)



Software, and Electronic Copies of
Software Manuals and User Manual

Shipping Precautions

DISCLAIMER / WARNING:

The shipping information provided in is a general overview of lithium battery shipping requirements; it does not provide complete shipping information. The information is provided as a courtesy, to be used as a guideline to assist properly trained shippers. These materials do not alter, satisfy, or influence any federal or state requirements. These materials are subject to change due to changes in government regulations. Sea-Bird accepts no liability for loss or damage resulting from changes, errors, omissions, or misinterpretations of these materials. **See the current edition of the IATA Dangerous Good Regulations for complete information on packaging, labeling, and shipping document requirements.**



WARNING!
Do not ship assembled battery pack.

Assembled battery pack

For its main power supply, the MicroCAT uses twelve 3.6-volt AA lithium cells (Saft LS14500). The MicroCAT was shipped from the factory with the cells packaged separately within the shipping box (not inside MicroCAT).

BATTERY PACKAGING

Cells are packed in heat-sealed plastic, and then placed in bubble-wrap outer sleeve and strong packaging for shipment.



If the shipment is not packaged as described above, or does not meet the requirements below, the shipment is considered Dangerous/Hazardous Goods, and must be shipped according to those rules.

	1-5 MicroCATs and associated cells, but no spares	1-5 MicroCATs and associated cells, plus up to 2 spare cell sets/MicroCAT	Spares (without MicroCATs) – Note new rules as of January 1, 2013
UN #	UN3091	UN3091	Must be shipped as Class 9 Dangerous Goods. If re-shipping spares, you must have your own Dangerous Goods program.
Packing Instruction (PI) #	969	969	
Passenger Aircraft	Yes	No	
Cargo Aircraft	Yes	Yes	
Labeling Requirement	1 **	1, 2 **	
Airway Bill (AWB) Requirement	Yes *	Yes *	

* AWB must contain following information in Nature and Quantity of Goods Box: "Lithium Metal Batteries", "Not Restricted", "PI #"

** Labels are defined below:



2

1 – Shipper must provide an emergency phone number

Note:

Remove the cells before returning the MicroCAT to Sea-Bird. Do not return used cells when shipping the MicroCAT for calibration or repair. All setup information is preserved when the cells are removed.

Install the battery pack assembly in the MicroCAT for testing (see *Battery Installation* in Section 3). **If you will re-ship the MicroCAT after testing:**

1. Remove the battery pack assembly from the MicroCAT.
2. Remove the cells from the battery pack assembly.
3. Pack the cells properly for shipment, apply appropriate labels, and prepare appropriate shipping documentation.

Section 2: Description of MicroCAT

This section describes the functions and features of the SBE 37-SMP-ODO **SDI-12** MicroCAT, including specifications, dimensions, end cap connectors, sample timing, battery pack endurance, and external power.

System Description



For most applications, deploy in orientation shown (connector end down) for proper operation – see [Optimizing Data Quality / Deployment Orientation in Section 4: Deploying and Operating MicroCAT](#)

The SBE 37-SMP-ODO **SDI-12** MicroCAT is a high-accuracy conductivity and temperature recorder (pressure optional) with internal battery pack and non-volatile memory, an integral pump, an SDI-12 interface, and an RS-232 serial interface. The MicroCAT also includes an Optical Dissolved Oxygen (DO) sensor (SBE 63). Designed for moorings and other long-duration, fixed-site deployments, these MicroCATs have non-corroding plastic *ShallowCAT* housings rated for operation to 350 meters (1150 feet) or pressure sensor full-scale range.

For setup and data upload, communication with the MicroCAT is over an internal, 3-wire, RS-232C link. Over 50 different commands can be sent to the MicroCAT to provide status display, data acquisition setup, data retrieval, and diagnostic tests.

User-selectable operating modes include:

- **Autonomous sampling** (not compatible with SDI-12 deployments) – At pre-programmed intervals, the MicroCAT wakes up, runs the pump, samples, stores the data in its FLASH memory, and goes to sleep. If desired, real-time data can also be transmitted.
- **Polled sampling** – On command, the MicroCAT runs the pump, takes one sample, and transmits the data. Alternatively, the MicroCAT can be commanded to transmit the last sample in its memory while it is sampling autonomously. Polled sampling is useful for integrating the MicroCAT with satellite, radio, or wire telemetry equipment.

The MicroCAT can be deployed in three ways:

- **Connected to RS-232 or USB port** on computer – The MicroCAT can be remotely controlled, allowing for polled sampling or for periodic requests of data from the MicroCAT memory while the MicroCAT is sampling autonomously. If desired, data can be periodically uploaded while the MicroCAT remains deployed. The MicroCAT can be externally powered.
- **Connected to SDI-12 controller** - The MicroCAT can be remotely controlled, allowing for polled sampling. The MicroCAT can be externally powered.
- **Dummy plug installed** – The MicroCAT cannot be remotely controlled or externally powered. Autonomous sampling is programmed before deployment, and data is uploaded after recovery.

Note:

If connected to a USB port, a RS-232 to USB converter is required. See [Application Note 68: Using USB Ports to Communicate with Sea-Bird Instruments](#).

Calibration coefficients stored in EEPROM allow the MicroCAT to transmit conductivity, temperature, pressure, and oxygen data in engineering units. The MicroCAT retains the temperature and conductivity sensors used in the SeaCAT and SeaCAT*plus* family. The MicroCAT's aged and pressure-protected thermistor has a long history of exceptional accuracy and stability (typical drift is less than 0.002 °C per year). Electrical isolation of the conductivity electronics eliminates any possibility of ground-loop noise.

The MicroCAT's internal-field conductivity cell is immune to proximity errors and unaffected by external fouling. The conductivity cell guard retains the expendable AF24173 Anti-Foulant Devices.

The MicroCAT's integral pump runs each time the MicroCAT takes a sample, providing the following advantages over a non-pumped system:

- Improved conductivity and oxygen response – The pump flushes the previously sampled water from the conductivity cell and oxygen sensor plenum, and brings a new water sample quickly into the system.
- Improved anti-foul protection – Water does not freely flow through the conductivity cell between samples, allowing the anti-foul concentration inside the system to maintain saturation.
- Improved measurement correlation – The individually calibrated SBE 63 Optical Dissolved Oxygen sensor is integrated within the CTD flow path, providing optimum correlation with CTD measurements.

With *Adaptive Pump Control*, the MicroCAT calculates the pump run time for best dissolved oxygen accuracy, as a function of the temperature and pressure of the previous sample.

Note that the MicroCAT was designed to be deployed as shown, with the sensor end up, providing an inverted U-shape for the flow. This orientation prevents sediment from being trapped in the plumbing. An air bleed hole allows air to escape from the plumbing, so the pump will prime. See *Optimizing Data Quality / Deployment Orientation* in *Section 4: Deploying and Operating MicroCAT*.

The MicroCAT's optional strain-gauge pressure sensor is available in the following pressure ranges: 20, 100, and 350 meters. Compensation of the temperature influence on pressure offset and scale is performed by the MicroCAT's CPU.

Future upgrades and enhancements to the MicroCAT firmware can be easily installed in the field through a computer serial port and the bulkhead connector on the MicroCAT, without the need to return the MicroCAT to Sea-Bird.

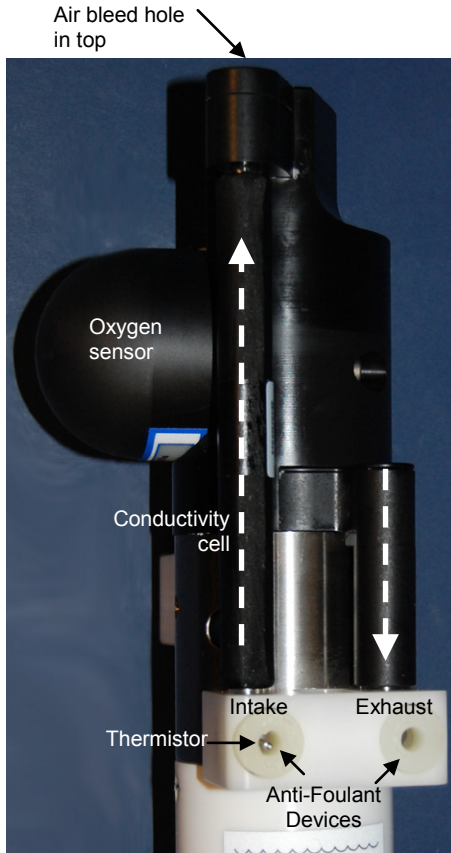

Shown with conductivity cell guard removed

Notes:

- Help files provide detailed information on the use of the software.
- A separate software manual on CD-ROM contains detailed information on the setup and use of SBE Data Processing.
- Sea-Bird supplies the current version of our software when you purchase an instrument. As software revisions occur, we post the revised software on our FTP site. See our website (www.seabird.com) for the latest software version number, a description of the software changes, and instructions for downloading the software from the FTP site.

The MicroCAT is supplied with a powerful software package, Seasoft[®] V2, which includes:

- **Deployment Endurance Calculator**– program for determining deployment length based on user-input deployment scheme, instrument power requirements, and battery pack capacity.
- **SeatermV2** – terminal program for easy setup and data retrieval. SeatermV2 is a *launcher*, and launches the appropriate terminal program for the selected instrument (**Seaterm232** for instruments that can communicate via RS-232, such as this MicroCAT).
- **SBE Data Processing** - program for calculation and plotting of conductivity, temperature, pressure (optional), oxygen, and derived variables such as salinity, sound velocity, depth, density, etc.

Specifications

	Temperature	Conductivity	Pressure	Dissolved Oxygen						
Measurement Range	-5 to +45 °C	0 to 7 (0 to 70 mS/cm)	0 to full scale range: 20 / 100 / 350 meters (expressed in meters of deployment depth capability)	See SBE 63 Optical Dissolved Oxygen Sensor manual						
Initial Accuracy	± 0.002 (-5 to 35 °C); ± 0.01 (35 to 45 °C)	± 0.0003 (0.003 mS/cm)	± 0.1% of full scale range							
Typical Stability	0.0002 °C / month	0.0003 (0.003 mS/cm) / month	0.05% of full scale range / year							
Resolution	0.0001 °C	0.00001 (0.0001 mS/cm)	0.002% of full scale range							
Sensor Calibration (measurement outside these ranges may be at slightly reduced accuracy due to extrapolation errors)	+1 to +32 °C	0 to 6; physical calibration over range 2.6 to 6 S/m, plus zero conductivity (air)	Ambient pressure to full scale range in 5 steps							
Memory	8 Mbyte non-volatile FLASH memory									
Data Storage	Conductivity & temperature: 6 bytes/sample (3 bytes each). Time: 4 bytes/sample. Oxygen: 6 bytes/sample. Pressure (optional): 5 bytes/sample.									
	<table border="1"> <thead> <tr> <th><u>Recorded Parameters</u></th> <th><u>Memory Space (number of samples)</u></th> </tr> </thead> <tbody> <tr> <td>C, T, DO, and time</td> <td>500,000</td> </tr> <tr> <td>C, T, P, DO, and time</td> <td>381,000</td> </tr> </tbody> </table>				<u>Recorded Parameters</u>	<u>Memory Space (number of samples)</u>	C, T, DO, and time	500,000	C, T, P, DO, and time	381,000
<u>Recorded Parameters</u>	<u>Memory Space (number of samples)</u>									
C, T, DO, and time	500,000									
C, T, P, DO, and time	381,000									
Real-Time Clock	32,768 Hz TCXO accurate to ±1 minute/year.									
Internal Battery Pack	Nominal 7.8 Amp-hour pack consisting of 12 AA Saft LS 14500 lithium cells (3.6 V and 2.6 Amp-hours each), with 3 strings of 4 cells. For battery pack endurance calculations, derated capacity of 257 KJoules. See <i>Battery Pack Endurance</i> for example sampling calculation. See <i>Shipping Precautions</i> in <i>Section 1: Introduction</i> . Note: Saft batteries can be purchased from Sea-Bird or other sources. See Saft's website for suppliers (www.saftbatteries.com). Alternatively, substitute either of the following: - Tadiran TL-4903, AA (3.6 V and 2.4 Amp-hours each) (www.tadiran.com) - Electrochem 3B0064/BCX85, AA (3.9 V and 2.0 Amp-hours each) (www.electrochemsolutions.com)									
External Power	0.25 Amps at 9 - 24 VDC. To avoid draining internal battery pack, use an external voltage greater than 10 VDC. See <i>External Power</i> .									
Power Consumption	<ul style="list-style-type: none"> • Quiescent: 78 microAmps (0.001 Watts) • Pump: 0.12 Watts (see <i>Pump Operation</i> for time that pump runs) • CTD-DO Sample Acquisition, with pressure (excluding pump): Real-time data enabled – 0.17 Watts (see <i>Sample Timing</i> for acquisition time) Real-time data disabled – 0.155 Watts (see <i>Sample Timing</i> for acquisition time) • CTD-DO Sample Waiting (pump running, not sampling), with pressure (excluding pump): Real-time data enabled and receive line valid – 0.056 Watts Real-time data enabled and receive line not valid – 0.016 Watts Real-time data disabled – 0.016 Watts • CTD-DO Between Samples, with pressure: Real-time data enabled and receive line valid – 0.056 Watts Real-time data enabled and receive line not valid – 0.0004 Watts Real-time data disabled – 0.0004 Watts • Communications: RS-232 - 0.065 Watts; SDI-12 - 0.024 Watts 									
Housing Material and Depth Rating	Plastic housing rated at 350 m (1150 ft)									
Weight (with mooring guide and clamp)	3.4 kg (7.5 lbs) in air, 1.5 kg (3.3 lbs) in water									

CAUTION:

See *Section 5: Routine Maintenance and Calibration* for handling instructions for the plastic *ShallowCAT* housing.

Dimensions and End Cap Connector

Note:
For most applications, deploy in the orientation shown (connector end down) for proper operation.

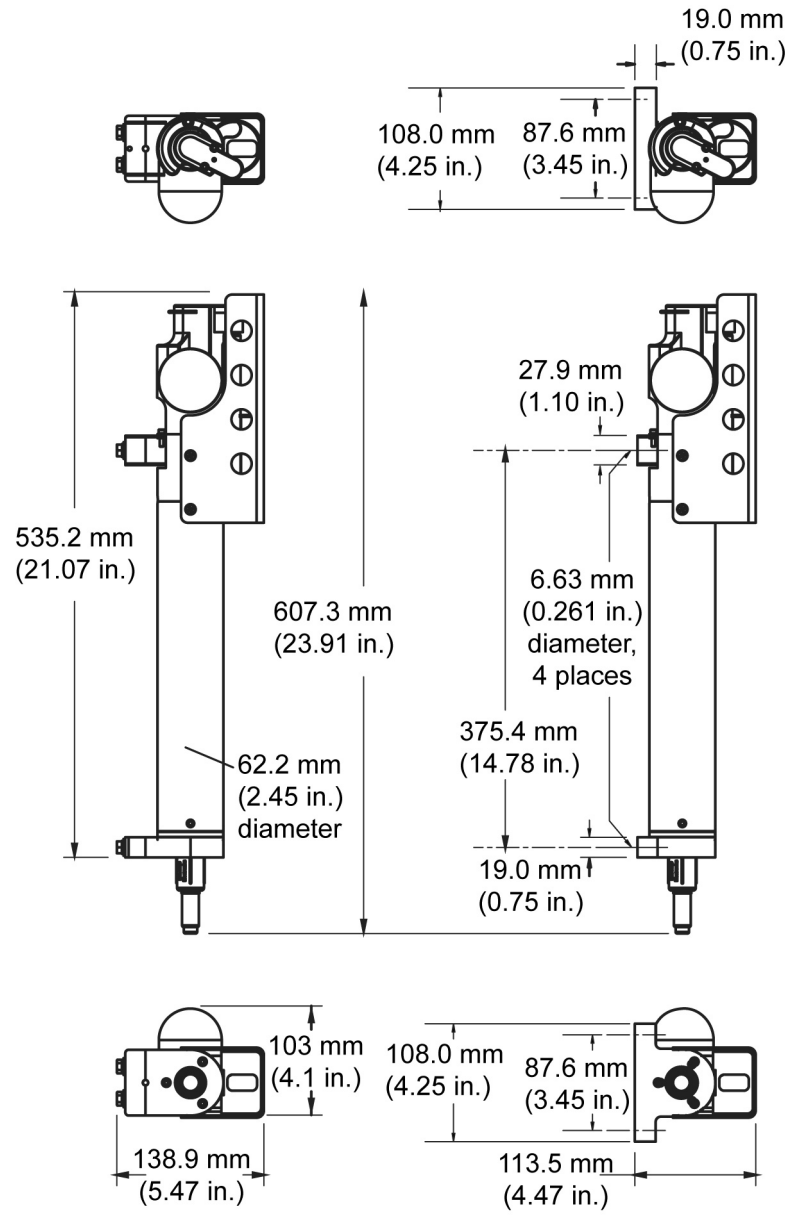

Standard Wire Mounting Clamp and Guide

Alternate Flat Surface Mounting Brackets

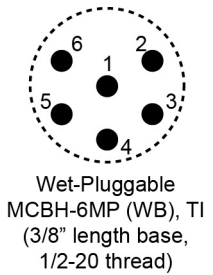

Pin	Signal
1	Common
2	RS-232 data receive
3	RS-232 data transmit
4	SDI-12 data transmit
5	--
6	9-24 VDC external power

Cables and Wiring

MCIL Wet-Pluggable Connector Cable Wiring -- DN 33733

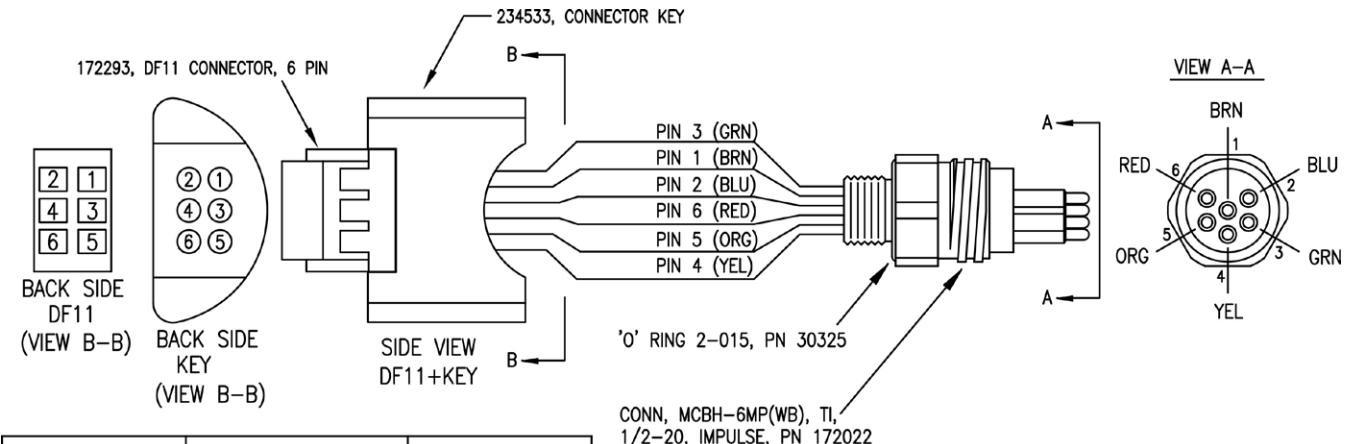
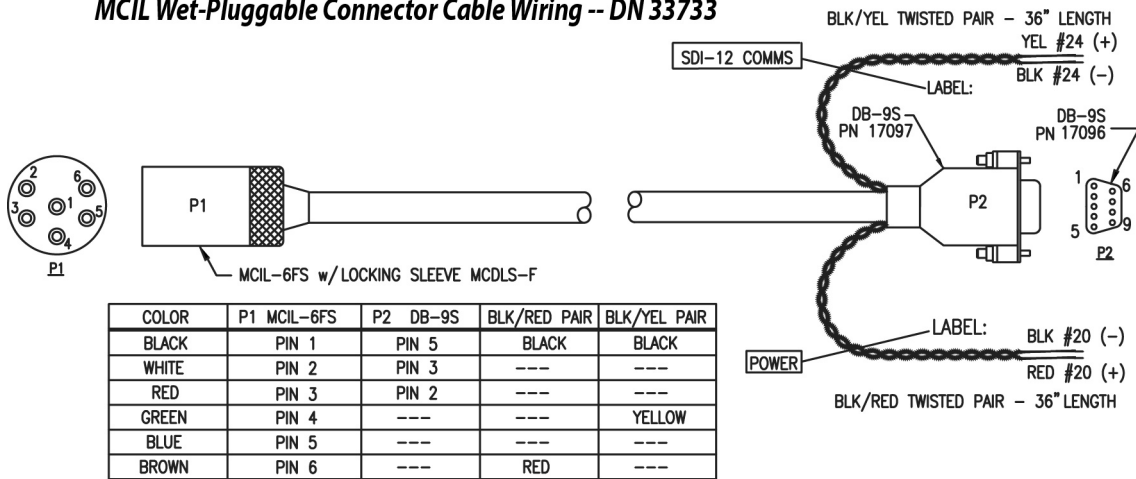

DF11 CONNECTOR	BULKHEAD CONNECTOR	FUNCTION
PIN 1	PIN 3 (GRN)	TX TO PC
PIN 2	PIN 1 (BRN)	COMMON
PIN 3	PIN 2 (BLU)	RX FROM PC
PIN 4	PIN 6 (RED)	EXTERNAL PWR
PIN 5	PIN 5 (ORG)	NO CONNECT
PIN 6	PIN 4 (YEL)	SDI-12

Pump Operation

Minimum Conductivity Frequency for Pump Turn-On

The MicroCAT's integral pump is water lubricated; running it *dry* for an extended period of time will damage it. To prevent the pump from running dry while sampling, the MicroCAT checks the raw conductivity frequency (Hz) from the last sample against the user-input minimum conductivity frequency (**MinCondFreq**). If the raw conductivity frequency is greater than **MinCondFreq**, it runs the pump before taking the sample; otherwise it does not run the pump.

If the minimum conductivity frequency is too close to the *zero conductivity frequency* (from the MicroCAT Calibration Sheet), the pump may turn on when the MicroCAT is in air, as a result of small drifts in the electronics. Some experimentation may be required to control the pump, particularly in fresh water applications.

By setting **MinCondFreq** to an appropriate value, you can start logging in the lab or on the ship in dry conditions; the pump will not run until you deploy the MicroCAT. Upon recovery, the MicroCAT will continue logging data but the pump will stop running, so a delay in getting the MicroCAT to the lab to send the **Stop** command will not damage the pump.

Pumping Time and Speed

The pump runs before and during sampling, providing flushing of the system consistent with the calibration of the oxygen sensor at our factory. The amount of time that the pump runs for each sample is a function of whether the *Adaptive Pump Control* is enabled.

- If enabled (**AdaptivePumpControl=Y**), the MicroCAT calculates the pump time **before** each sample for best oxygen accuracy, as a function of the temperature and pressure of the previous sample (temperature and pressure influence the oxygen sensor time constant). Pump time increases with increasing pressure and decreasing temperature. The pump continues to run while sampling. See next page for algorithm.
- If not enabled (**AdaptivePumpControl=N**), the pump runs for a user-programmable amount of time (a multiple of the oxygen sensor response time) **before** each sample, and then continues to run while sampling. **Adaptive pump control should be disabled only for testing and calibration.**

$$\text{pump time} = \text{OxNTau} * \text{OxTau20}$$
where

$$\text{OxTau20} = \text{oxygen calibration coefficient (OxTau20=)}$$

$$\text{OxNTau} = \text{pump time multiplier (OxNTau=)}$$

Note:

The pump continues to run while the MicroCAT takes the sample. See *Sample Timing* below for the time to take each sample, which varies depending on the sampling mode, command used to start sampling, whether real-time data is transmitted, and whether the MicroCAT includes a pressure sensor.

For testing and/or to remove sediment from inside the plumbing, the pump can be *manually* turned on and off with the **PumpOn** and **PumpOff** commands.

The *Adaptive Pump Control* algorithm and operation is detailed below.

Notes:

- OxTau20 is programmed into the MicroCAT at the factory (**OxTau20=**).
- If the MicroCAT does not include a pressure sensor, the *Adaptive Pump Control* algorithm uses **ReferencePressure=** in place of the measured pressure.
- The calculated Pump Time does not include the pumping while sampling.

$$ft = A + (B * T) + (C * T^2)$$

$$fp = e^{(pcor * P)}$$

$$\tau = \text{OxTau20} * ft * fp \quad (\text{minimum } \tau 2.0, \text{ maximum } \tau 30.0)$$

$$\text{pump time} = \text{OxNTau} * \tau \quad (\text{minimum pump time } 3.0)$$

where

$$A = 2.549$$

$$B = -1.106 \times 10^{-1}$$

$$C = 1.571 \times 10^{-3}$$

$$pcor = 1.45 \times 10^{-4}$$

OxTau20 = oxygen calibration coefficient (**OxTau20=**)

OxNTau = pump time multiplier (**OxNTau=**)

P = measured pressure (decibars)

T = measured temperature (°C)

Looking at pump times in the range of oceanographic values, and using a typical OxTau20 value of 5.5 and OxNTau value of 7.0:

(for OxTau20=5.5 and OxNTau=7.0)					
T (°C)	P (db)	Ft	Fp	Tau	Pump Time <i>before sampling (sec)</i>
-3	1500	2.89	1.24	19.7	138
-3	0	2.89	1.0	15.9	111
0	0	2.549	1.0	14.0	98
0	1500	2.549	1.24	17.3	121
4	0	2.132	1.0	11.7	82
4	1500	2.132	1.24	14.5	102
20	0	0.9654	1.0	5.3	37
20	1500	0.9654	1.24	6.6	46

Note that the adaptive pump control operation can impact the interval between samples. The total time for each sample is the calculated pump time plus the actual sampling time (the pump continues to run while sampling). The MicroCAT requires a minimum of 3 seconds after taking a sample to the start of the next sampling interval. If the time required to run the pump is too large, it will not be able to take samples at the user-programmed **SampleInterval=**. If that occurs, the MicroCAT starts the next sampling interval 5 seconds after the end of the previous sampling interval.

Sea-Bird recommends that you calculate the expected pumping time based on the algorithm above, the planned deployment pressure, and the worst (i.e., the coldest) expected temperature. Do not set the sample interval (**SampleInterval=**) to less than (pumping time + sampling time + 5 sec).

Sample Timing

Notes:

- Acquisition time shown does not include time to transmit real-time data, which is dependent on baud rate (**BaudRate=**) and number of characters being transmitted (defined by **OutputFormat=** and commands to enable/disable specific output parameters).
- Time stored and output with the data is the time at the **start** of the sample, after the MicroCAT wakes up, runs the pump, and prepares to sample.

Sample timing is dependent on several factors, including sampling mode, command used to start sampling, whether real-time data is transmitted, and whether the MicroCAT includes a pressure sensor

Autonomous Sampling (time between samples = **SampleInterval**)

Power on time for each sample while logging:

- **Without pressure, no real-time data:** power-on time = 2.4 sec
- **Without pressure, with real-time data:** power-on time = 2.8 sec

If the MicroCAT includes a pressure sensor, add 0.4 sec to the time.

Polled Sampling

Time from receipt of take sample command to beginning of reply:

- **Without pressure:** power-on time = 2.7 sec

If the MicroCAT includes a pressure sensor, add 0.4 sec to the time.

Battery Pack Endurance

Notes:

- If the MicroCAT is logging data and the battery voltage is less than 7.1 volts for five consecutive scans, the MicroCAT halts logging.
- Sea-Bird recommends using the capacity value of 6.0 Amp-hours for the Saft cells as well as the alternate cell types (Tadiran TL-4903 and Electrochem 3B0064/BCX85 AA).
- The 37-SMP-ODO uses a battery pack with a **yellow** cover plate. Older MicroCATs without dissolved oxygen use a battery pack with a red cover plate; **the wiring of that pack is different from this one, and cannot be used with the 37-SMP-ODO.**
- See *Specifications* above for data storage limitations.

The battery pack (4 cells in series, 3 parallel strings) has a nominal capacity of 7.8 Amp-hours (2.6 Amp-hours * 3). For planning purposes, to account for the MicroCAT's current consumption patterns and for environmental conditions affecting cell performance, **Sea-Bird recommends using a conservative value of 6.0 Amp-hours.**

- Power consumption is defined above in *Specifications*.
- The time required for data acquisition for each sample is defined above in *Sample Timing*.
- The pump time using the Adaptive Pump Control algorithm is described above in *Pumping Time and Speed*.

So, battery pack endurance is highly dependent on the application. An example is shown below for one sampling scheme. **You can use the Deployment Endurance Calculator** to determine the maximum deployment length, instead of performing the calculations by hand.

Example 1 – real-time RS-232 communication at 9600 baud while sampling:

A MicroCAT with pressure is sampling autonomously every 10 minutes (6 samples/hour). Real-time data is enabled, but the receive line is not valid between samples, to minimize the power required from the MicroCAT and from the controller. Adaptive Pump Control is enabled. The MicroCAT is set up to transmit salinity, sound velocity, and specific conductivity as well as C, T, P, and DO. The MicroCAT is to be deployed at approximately 500 db; expected temperature there is approximately 10 °C. Oxtau20 (programmed into the MicroCAT at the factory) is 5.5, and OxNTau is 7.0. How long can it be deployed?

CTD-DO Sampling = 0.17 Watts * 3.2 sec sampling time = 0.544 Joules/sample

In 1 hour, sampling consumption = 6 samples/hour * 0.544 Joules/sample = **3.26 Joules/hour**

Pump

$ft = A + (B * T) + (C * T^2) = 2.549 + (-1.106 \times 10^{-1} * 10) + (1.571 \times 10^{-3} * 10 * 10) = 1.600$

$fp = e^{(pcor * P)} = e^{(1.45e-4 * 500)} = 1.075$

tau = OxTau20 * ft * fp = 5.5 * 1.600 * 1.075 = 9.46

Pump Time = OxNTau * tau = 7.0 * 9.46 = 66.2 sec (> Minimum Pump Time = 3 sec)

From above, pump runs for an additional 3.2 sec while sampling.

Pumping, 0.12 Watts * (66.2 + 3.2) sec = 8.33 Joules/sample

In 1 hour, pump consumption = 6 samples/hour * 8.33 Joules/sample = **49.98 Joules/hour**

CTD-DO Waiting while pump running = 0.016 Watts * 66.2 sec = 1.06 Joules/sample

In 1 hour, consumption = 6 samples * 1.06 Joules/sample = **6.36 Joules/hour**

CTD-DO Waiting between Samples = 0.001 Watts * (600 – [66.2 + 3.2]) sec = 0.53 Joules/sample

In 1 hour, consumption = 6 samples/hour * 0.53 Joules/sample = **3.18 Joules/hour**

Communications – assume outputting temperature, conductivity, pressure, oxygen, salinity, sound velocity, specific conductivity, sample number; see *Data Formats* in *Section 4: Deploying and Operating MicroCAT*.

Number of characters transmitted/sample = 7(T) + 2(comma&space) + 7(C) + 2 + 7(P) + 2 + 6(DO) + 2 + 8(salinity) + 2 + 8 (sound velocity) + 2 + 7(specific conductivity) + 2(comma&space) + 11 (date) + 2 + 8 (time) + 2 + 6 = 93

Time required to transmit data = 93 characters * 10 bits/character / 9600 baud = 0.1 sec

Communication power/sample = 0.065 Watts * 0.1 sec = 0.065 Joules/sample

In 1 hour, consumption = 6 samples/hour * 0.065 Joules/sample = **0.04 Joules/hour**

Total consumption / hour = 3.26 + 49.98 + 6.36 + 3.18 + 0.04 = **62.8 Joules/hour**

Battery pack capacity

Assume nominal voltage of 14 V and 85% DC/DC converter efficiency

14 V * 6 Amp-hours * 3600 sec/hour * 0.85 = 257040 Joules

Capacity = 257040 Joules / 62.8 Joules/hour = 4093 hours = 170 days = **0.47 years**

Number of samples = 4093 hours * 6 samples/hour = **24,558 samples**

Example 2 – Same as Example 1, but SDI-12 controller polls for last sample to be transmitted 6 times/hour.

SDI-12 communication is always at 1200 baud:

All values same as in Example 1, with exception of Communications power.

Communications – assume outputting temperature, conductivity, pressure, oxygen, salinity, sound velocity, specific conductivity, sample number; see *Data Formats* in *Section 4: Deploying and Operating MicroCAT*.

Number of characters transmitted/sample = 1 (address) + 10(T) + 10(C) + 10(P) + 7(DO) + 10(salinity) + 9 (sound velocity) + 10(specific conductivity) + 7 (sample number) = 74

Time required to transmit data = 74 characters * 10 bits/character / 1200 baud = 0.62 sec

Communication power/sample = 0.024 Watts * (0.62) sec = 0.015 Joules/sample

In 1 hour, consumption = 6 samples/hour * 0.015 Joules/sample = **0.09 Joules/hour**

Total consumption / hour = 3.26 + 49.98 + 6.36 + 3.18 + 0.09 = **62.9 Joules/hour**

Battery pack capacity

Capacity = 257040 Joules / 62.9 Joules/hour = 4087 hours = 170 days = **0.46 years**

Number of samples = 4087 hours * 6 samples/hour = **24,522 samples**

External Power

The MicroCAT can be powered from an external source that supplies 0.25 Amps at 9-24 VDC. The internal lithium pack is diode-OR'd with the external source, so power is drawn from whichever voltage source is higher. The MicroCAT can also be operated from the external supply without having the battery pack installed. Electrical isolation of conductivity prevents ground loop noise contamination in the conductivity measurement.

Note:

See *Real-Time Data Acquisition* in *Section 4: Deploying and Operating MicroCAT* for baud rate limitations on cable length if transmitting real-time data.

Note:

Common wire resistances:

Gauge	Resistance (ohms/foot)
12	0.0016
14	0.0025
16	0.0040
18	0.0064
19	0.0081
20	0.0107
22	0.0162
24	0.0257
26	0.0410
28	0.0653

Cable Length and External Power

There are two issues to consider if powering the MicroCAT externally:

- Limiting the communication IR loss to 1 volt **if transmitting real-time data via RS-232**; higher IR loss will cause the instrument to transmit data that does not meet the RS-232 communication standard.
- Supplying enough power at the power source so that sufficient power is available at the instrument after considering IR loss.

Each issue is discussed below.

Limiting Communication IR Loss to 1 Volt if Transmitting Real-Time Data

The limit to cable length is typically reached when the maximum **communication** current times the power common wire resistance is more than 1 volt.

$$V_{\text{limit}} = 1 \text{ volt} = IR_{\text{limit}}$$

$$\text{Maximum cable length} = R_{\text{limit}} / \text{wire resistance per foot}$$

where I = communication current required by MicroCAT (see *Specifications*: 0.065 Watts / 13 Volts = 0.005 Amps = 5 milliAmps).

Example 1 – For 20 gauge wire, what is maximum distance to transmit power to MicroCAT if transmitting real-time data?

For 5 milliAmp communications current, $R_{\text{limit}} = V_{\text{limit}} / I = 1 \text{ volt} / 0.005 \text{ Amps} = 200 \text{ ohms}$

For 20 gauge wire, resistance is 0.0107 ohms/foot.

Maximum cable length = $200 \text{ ohms} / 0.0107 \text{ ohms/foot} = 18691 \text{ feet} = 6568 \text{ meters}$

Example 2 – Same as above, but there are 4 MicroCATs powered from the same power supply.

For 4.3 milliAmp communications current, $R_{\text{limit}} = V_{\text{limit}} / I = 1 \text{ volt} / (0.005 \text{ Amps} * 4 \text{ MicroCATs}) = 50 \text{ ohms}$

Maximum cable length = $50 \text{ ohms} / 0.0107 \text{ ohms/foot} = 4672 \text{ feet} = 1424 \text{ meters}$ (to MicroCAT *furthest* from power source)

Supplying Enough Power to MicroCAT

Another consideration in determining maximum cable length is supplying enough power at the power source so that sufficient voltage is available, after IR loss in the cable (**from the 0.25 Amp turn-on transient, two-way resistance**), to power the MicroCAT. The power requirement varies, depending on whether *any* power is drawn from the battery pack:

- Provide at least 10 volts, after IR loss, to prevent the MicroCAT from drawing **any** power from the battery pack (if you do not want to draw down the battery pack): $V - IR \geq 10$ volts
- Provide at least 9 volts, after IR loss, if allowing the MicroCAT to draw down the battery pack or if no battery pack is installed: $V - IR \geq 9$ volts
where I = MicroCAT turn-on transient (0.25 Amps; see *Specifications*).

Example 1 – For 20 gauge wire, what is maximum distance to transmit power to MicroCAT if using 12 volt power source and deploying MicroCAT with no battery pack?

$$V - IR \geq 9 \text{ volts} \quad 12 \text{ volts} - (0.25 \text{ Amps}) * (0.0107 \text{ ohms/foot} * 2 * \text{cable length}) \geq 9 \text{ volts}$$

$$3 \text{ volts} \geq (0.25 \text{ Amps}) * (0.0107 \text{ ohms/foot} * 2 * \text{cable length}) \quad \text{Cable length} \leq 560 \text{ ft} = 170 \text{ meters}$$

Note that 170 m << 6568 m (maximum distance if MicroCAT is transmitting real-time data), so IR drop in power is controlling factor for this example. Using a higher voltage power supply or a different wire gauge would increase allowable cable length.

Example 2 – Same as above, but there are 4 MicroCATs powered from same power supply.

$$V - IR \geq 9 \text{ volts} \quad 12 \text{ volts} - (0.25 \text{ Amps} * 4 \text{ MicroCATs}) * (0.0107 \text{ ohms/foot} * 2 * \text{cable length}) \geq 9 \text{ volts}$$

$$3 \text{ volts} \geq (0.25 \text{ Amps} * 4 \text{ MicroCATs}) * (0.0107 \text{ ohms/foot} * 2 * \text{cable length})$$

$$\text{Cable length} \leq 140 \text{ ft} = 42 \text{ meters (to MicroCAT furthest from power source)}$$

Section 3: Preparing MicroCAT for Deployment

This section describes the pre-check procedure for preparing the MicroCAT for deployment. Installation of the battery pack, installation of Sea-Bird software, and testing power and communications are discussed.

Battery Pack Installation

WARNING!
Do not ship the MicroCAT with battery pack installed. See *Shipping Precautions* in *Section 1: Introduction*.

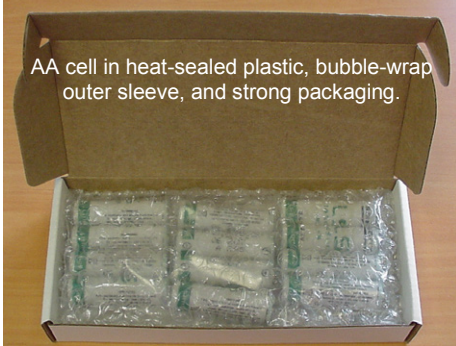

AA cell in heat-sealed plastic, bubble-wrap outer sleeve, and strong packaging.

CAUTION:
See *Section 5: Routine Maintenance and Calibration* for handling instructions for the plastic *ShallowCAT* housing.

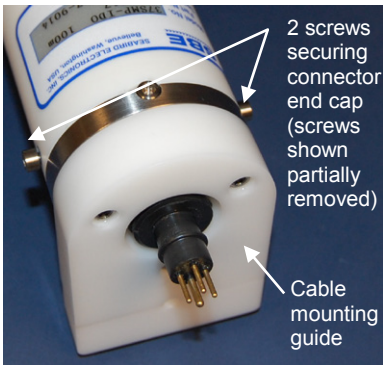

2 screws securing connector end cap (screws shown partially removed)

Cable mounting guide

Note: XSG connector shown; end cap removal details identical for MCBH connector (for this MicroCAT).

Twist end cap counter clockwise, twisting cap screw out of machined slot; end cap releases from housing.

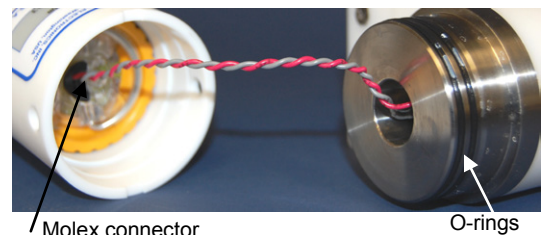
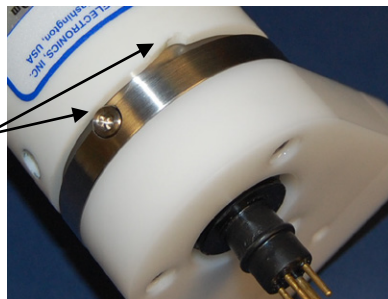

Molex connector

O-rings

Description of Cells and Battery Pack

Sea-Bird supplies twelve 3.6-volt AA lithium cells, shipped with the MicroCAT in a heat-sealed plastic bag placed in bubble wrap and a cardboard box. The empty cell holder is installed inside the MicroCAT for shipment.

No soldering is required when assembling the battery pack.

Installing Cells and Battery Pack

1. Remove the I/O connector end cap:
 - A. Wipe the outside of the end cap and housing dry, being careful to remove any water at the seam between them.
 - B. Remove the 2 cap screws on the sides of the housing. Do not remove any other screws.
Note: Sea-Bird ships the MicroCAT with a 9/64-inch Allen wrench for these screws.
 - C. Remove the I/O end cap by twisting the end cap counter clockwise; the end cap will release from the housing. Pull the end cap out.
 - D. The end cap is electrically connected to the electronics with a Molex connector. Holding the wire cluster near the connector, pull gently to detach the female end of the connector from the pins.
 - E. Remove any water from the O-ring mating surfaces inside the housing with a lint-free cloth or tissue.
 - F. Put the end cap aside, being careful to protect the O-rings from damage or contamination.

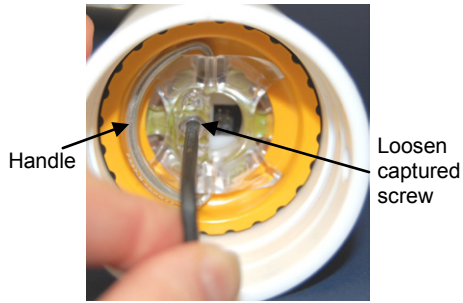

2. Remove the battery pack assembly from the housing:
 - A. Loosen the captured screw from the battery pack cover plate, using the 7/64-inch Allen wrench included with the shipment.
 - B. Lift the battery pack assembly straight out of the housing, using the handle.
3. Keep the handle in an upright position. Holding the edge of the **yellow** cover plate, unscrew the cover plate from the battery pack assembly. Note: Older MicroCATs without dissolved oxygen use a battery pack with a red cover plate; the wiring of that pack is different from this one, and **cannot be used with the 37-SMP-ODO**.

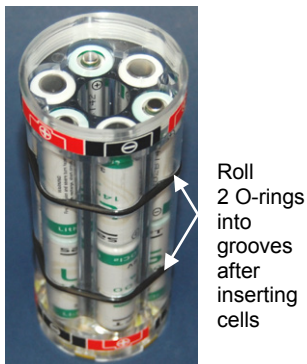
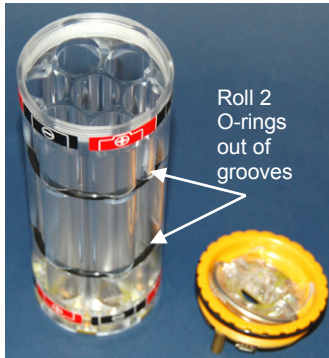

4. Roll the 2 O-rings on the outside of the battery pack out of their grooves.
5. Insert each cell into the pack, **alternating** positive (+) end first and negative (-) end first to match the labels on the pack.
6. Roll the 2 O-rings on the outside of the battery pack into place in the grooves. The O-rings compress the side of the battery pack and hold the cells tightly in place in the pack.
7. Reinstall the battery pack cover plate:
 - A. Align the pin on the battery pack cover plate PCB with the post hole in the battery pack housing.
 - B. Place the handle in an upright position. Screw the yellow cover plate onto the battery pack assembly. Ensure the cover is tightly screwed on to provide a reliable electrical contact.

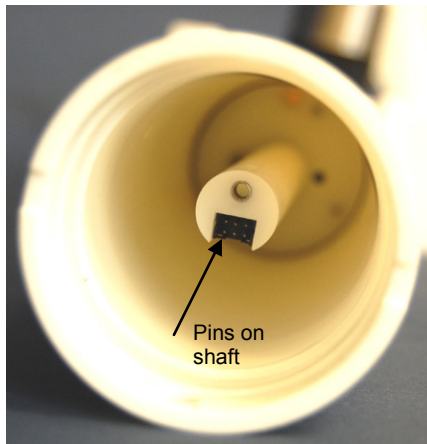
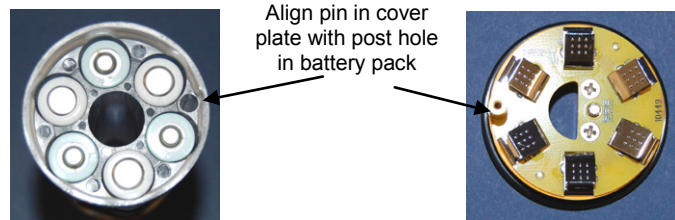

8. Replace the battery pack assembly in the housing:
 - A. Align the D-shaped opening in the cover plate with the pins on the shaft. Lower the assembly slowly into the housing, and once aligned, push gently to mate the banana plugs on the battery compartment bulkhead with the lower PCB. A post at the bottom of the battery compartment mates with a hole in the battery pack's lower PCB to prevent improper alignment.
 - B. Secure the assembly to the shaft with the captured screw, using the 7/64-inch Allen wrench. Ensure the screw is tight to provide a reliable electrical contact.
9. Reinstall the I/O connector end cap:
 - A. Remove any water from the O-rings and mating surfaces in the housing with a lint-free cloth or tissue. Inspect the O-rings and mating surfaces for dirt, nicks, and cuts. Clean as necessary. Apply a light coat of O-ring lubricant (Parker Super O Lube) to the O-rings and mating surfaces.
 - B. Plug the female end of the Molex connector onto the pins.
 - C. Carefully fit the end cap into the housing until the O-rings are fully seated.
 - D. Reinstall the 2 cap screws to secure the end cap.

Software Installation

Notes:

- Help files provide detailed information on the software. A separate software manual on the CD-ROM contains detailed information on SBE Data Processing.
- It is possible to use the MicroCAT without the SeatermV2 terminal program by sending direct commands from a dumb terminal or terminal emulator, such as Windows HyperTerminal.
- Sea-Bird supplies the current version of our software when you purchase an instrument. As software revisions occur, we post the revised software on our FTP site. See our website (www.seabird.com) for the latest software version number, a description of the software changes, and instructions for downloading the software from the FTP site.

Seasoft V2 was designed to work with a PC running Windows XP service pack 2 or later, Windows Vista, or Windows 7.

If not already installed, install Sea-Bird software programs on your computer using the supplied software CD:

1. Insert the CD in your CD drive.
2. Install software: Double click on **SeasoftV2.exe**. Follow the dialog box directions to install the software. The installation program allows you to install the desired components. Install all the components, or just install Deployment Endurance Calculator (battery endurance calculator), SeatermV2 (terminal program *launcher* for the MicroCAT) and SBE Data Processing (data processing).

The default location for the software is c:\Program Files\Sea-Bird. Within that folder is a sub-directory for each program.

Power and Communications Test

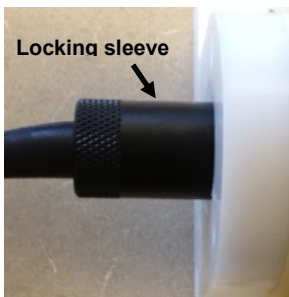
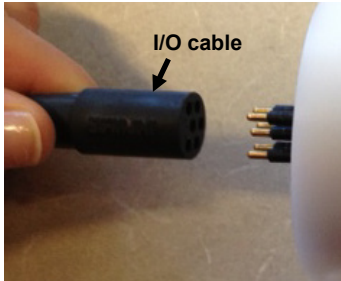

The power and communications test will verify that the system works, prior to deployment.

Test Setup

1. Remove dummy plug (if applicable):
 - A. By hand, unscrew the locking sleeve from the MicroCAT's bulkhead connector. If you must use a wrench or pliers, be careful not to loosen the bulkhead connector instead of the locking sleeve.
 - B. Remove the dummy plug from the MicroCAT's I/O bulkhead connector by pulling the plug firmly away from the connector.
2. Install the I/O cable connector, aligning the pins.
3. Connect the I/O cable connector to your computer's serial port.

Note:
See SeatermV2's Help files.

Test

1. Double click on **SeatermV2.exe**. The main screen looks like this:

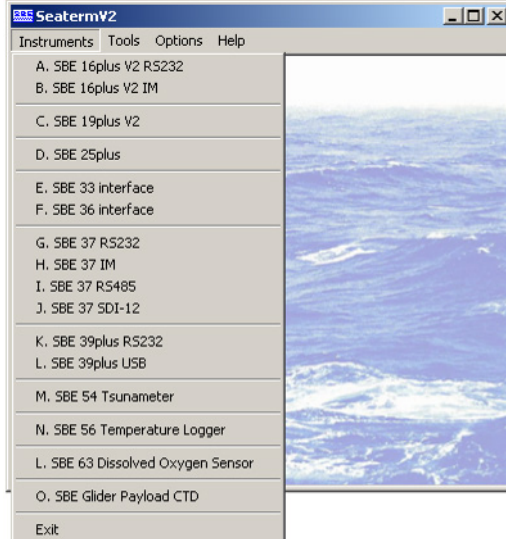

SeatermV2 is a *launcher*, and launches the appropriate terminal program for the selected instrument.

Note:
See Seaterm232's Help files.

2. In the Instruments menu, select *SBE 37 RS232*. **Seaterm232** opens; the main screen looks like this:

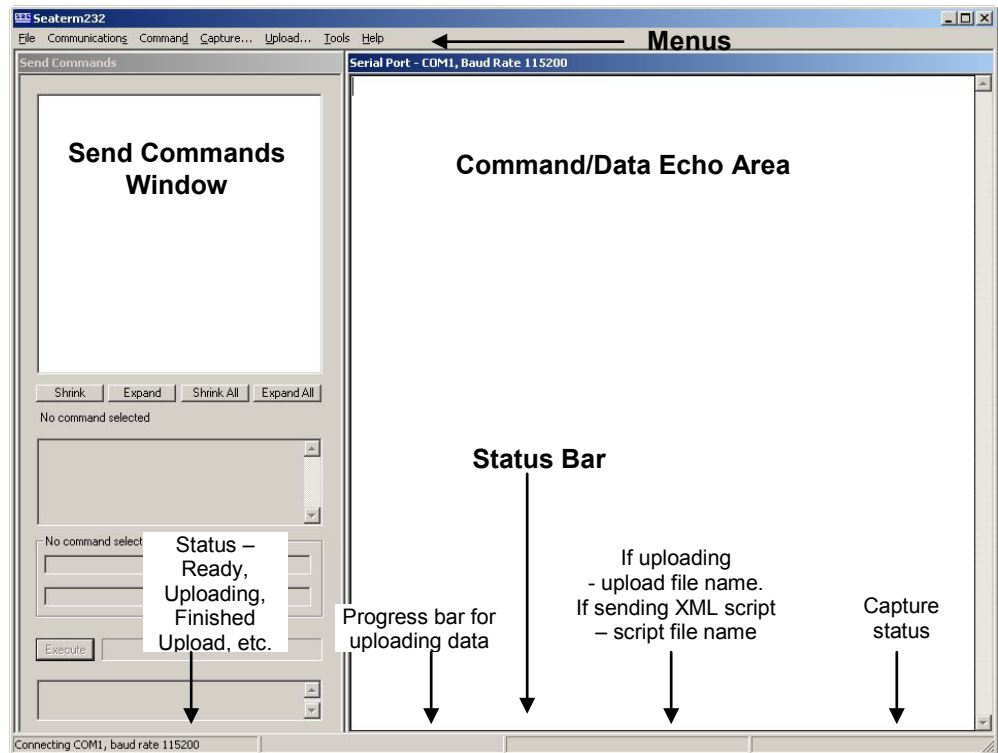

- **Menus** – For tasks and frequently executed instrument commands.
- **Send Commands window** – Contains commands applicable to your MicroCAT. The list appears after you connect to the MicroCAT.
- **Command/Data Echo Area** – Title bar of this window shows Seaterm232's current comm port and baud rate. Commands and the MicroCAT responses are echoed here. Additionally, a command can be manually typed or pasted (ctrl + V) here. Note that the MicroCAT must be *connected* and *awake* for it to respond to a command.
- **Status bar** – Provides connection, upload, script, and capture status information.

Following is a description of the menus:

Menu	Description	Equivalent Command*
File	<ul style="list-style-type: none"> • Load command file – opens selected .XML command file, and fills Send Commands window with commands. • Unload command file – closes command file, and removes commands from Send Commands window. • Exit - Exit program. 	-
Communications	<ul style="list-style-type: none"> • Configure – Establish communication parameters (comm port and baud rate). • Connect – connect to comm port. • Disconnect – disconnect from comm port. • Disconnect and reconnect – may be useful if instrument has stopped responding. 	-
Command	<ul style="list-style-type: none"> • Abort – interrupt and stop MicroCAT's response. • Send 5 second break (not applicable to 37-SMP-ODO). • Send stop command. • Set local time– Set date and time to time sent by timekeeping software on your computer; accuracy ± 25 msec of time provided by computer. • Set UTC Time (Greenwich Mean Time) – Set date and time to time sent by timekeeping software on your computer; accuracy ± 25 msec of time provided by computer. 	<ul style="list-style-type: none"> • (press Esc key several times for Abort) • Stop • DateTime= • DateTime=
Capture	Capture instrument responses on screen to file, to save real-time data or use for diagnostics. File has .cap extension. Click Capture menu again to turn off capture. Capture status displays in Status bar.	—
Upload	Upload data stored in memory, in a format that Sea-Bird's data processing software can use. Uploaded data has .xml extension, and is then automatically converted to a .hex and a .xmlcon file that can be used in SBE Data Processing's Data Conversion module. Before using Upload: stop logging by sending Stop .	Several status commands and appropriate data upload command as applicable to user selection of range of data to upload (use Upload menu if you will be processing data with SBE Data Processing)
Tools	<ul style="list-style-type: none"> • Diagnostics log - Keep a diagnostics log. • Convert .XML data file – Using Upload menu automatically does this conversion; tool is available if there was a problem with the automatic conversion. • Send script – Send XML script to MicroCAT. May be useful if you have a number of MicroCATs to program with same setup. 	-

Note:

Set local time and *Set UTC time* are disabled if the baud rate in Seaterm232 is set to 115200, because the software cannot reliably set the time at that baud.

*See *Command Descriptions* in Section 4: *Deploying and Operating MicroCAT*.

3. If this is the first time Seaterm232 is being used, the configuration dialog box displays:

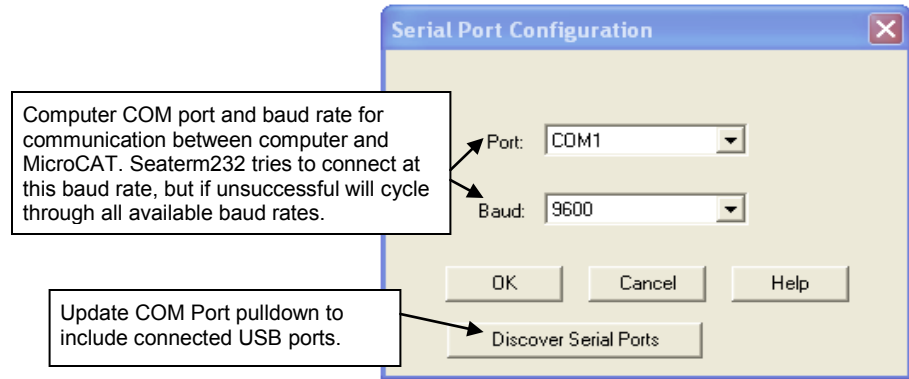

Make the desired selections, and click OK.

Note:

Seaterm232's baud rate must be the same as the MicroCAT baud rate (set with **BaudRate=**). Baud is factory-set to 9600, but can be changed by the user (see *Command Descriptions* in *Section 4: Deploying and Operating MicroCAT*). Other communication parameters – 8 data bits, 1 stop bit, and no parity – cannot be changed.

4. Seaterm232 tries to automatically connect to the MicroCAT. As it connects, it sends **GetHD** and displays the response, which provides factory-set data such as instrument type, serial number, and firmware version. Seaterm232 also fills the Send Commands window with the correct list of commands for your MicroCAT.

If there is no communication:

- In the Communications menu, select *Configure*. The Serial Port Configuration dialog box appears. Select the Comm port and baud rate for communication, and click OK. Note that the factory-set baud rate is documented on the Configuration Sheet.
- In the Communications menu, select *Connect* (if *Connect* is grayed out, select *Disconnect and reconnect*). Seaterm232 will attempt to connect at the baud specified in Step A, but if unsuccessful will then cycle through all other available baud rates.
- If there is still no communication, check cabling between the computer and MicroCAT, and try to connect again.
- If there is still no communication, repeat Step A with a different comm port, and try to connect again.

Note:

If **OutputExecutedTag=Y**, the MicroCAT does **not** provide an S> prompt after the **<Executed/>** tag at the end of a command response.

After Seaterm232 displays the **GetHD** response, it provides an S> prompt to indicate it is ready for the next command.

Note:
For this Beta version, the Send Commands window does not fill with commands. You must manually type commands in the Commands/Data Echo Area.

Taking a look at the Send Commands window:

The screenshot shows the 'Send Commands' window for 'SBE37SMP-ODO SDI-12 Commands'. The window has a tree view on the left with the following items: Status, General Setup, RS-232 Setup, SDI-12 Setup, Pump Setup, SBE 63 ODO Sensor Setup, Memory Setup, Output Format Setup, Autonomous Sampling (logging), Polled Sampling, Data Upload, and Calibration Coefficients. The 'Data Upload' item is expanded, showing two sub-items: 'Upload data from FLASH memory' (which is selected) and another 'Upload data from FLASH memory'. Below the tree view are buttons for 'Shrink', 'Expand', 'Shrink All', and 'Expand All'. Below these buttons is a section titled 'Help for command GetSamples:' with a text area containing the text: 'Upload selected data from FLASH memory in format defined by OutputFormat=. If starting and ending sample numbers are omitted, all data is uploaded.' Below the help text is a section titled 'Arguments for command GetSamples:' with two input boxes labeled 'Starting sample number' and 'Ending sample number'. At the bottom left is an 'Execute' button. At the bottom right is a text area labeled 'GetSamples:' with the text 'This box shows selected command.' below it. A callout box on the left points to the 'Upload data from FLASH memory' item with the text 'Click on desired command description in list.' Another callout box on the left points to the help text with the text 'Help box describes selected command in more detail.' A third callout box on the left points to the 'Starting sample number' and 'Ending sample number' boxes with the text 'Enter any command arguments (such as starting and ending sample number for upload) in these boxes.' A fourth callout box on the left points to the 'Execute' button with the text 'Click Execute when ready to send selected command.'

You can use the Send Commands window to send commands, or simply type the commands in the Command/Data Echo area if desired.

Note:

The MicroCAT automatically enters quiescent (sleep) state after 2 minutes without receiving a command. This timeout algorithm is designed to conserve battery pack energy if the user does not send **QS** to put the MicroCAT to sleep. If the system does not appear to respond, select *Connect* in the Communications menu to reestablish communications.

5. Display MicroCAT status information typing **DS** and pressing the Enter key. The display looks like this:

```
SBE37SMP-ODO-SDI12 v2.4.2 SERIAL NO. 10103 11 Oct 2013 20:48:03
vMain = 13.08, vLith = 3.17
samplenumber = 172, free = 399285
not logging, stop command
sample interval = 300 seconds
data format = converted engineering
output temperature, Celsius
output conductivity, uS/cm
output pressure, PSI
output oxygen, mg/L
output salinity, PSU
output sound velocity, m/s
output specific conductivity, uS/cm
user defined specific conductivity coefficient = 0.0200
output sample number
transmit real time data= yes
minimum conductivity frequency = 3224.1
adaptive pump control enabled
nTau = 7.0
SDI-12 address = 0
SDI-12 flag = +9999999
```

6. Command the MicroCAT to take a sample by typing **TS** and pressing the Enter key. The display looks like this if pressure sensor installed, all output parameters are enabled, and **OutputFormat=1** (converted engineering units):

```
23.1109, 0.2, -6.775, 0.001, 1.0942, 1492.642,
0.2, 11 Oct 2013, 07:44:26
```

where

- 23.1109 = temperature in degrees Celsius (output if **OutputTemp=Y**, units set by **SetTempUnits=**)
- 0.2 = conductivity in $\mu\text{S}/\text{cm}$ (output if **OutputCond=Y**, units set by **SetCondUnits=**)
- -6.775 = pressure in PSI (output if **OutputPress=Y**, units set by **SetPressUnits=**)
- 0.001 = dissolved oxygen in mg/l (output if **OutputOx=Y**, units set by **SetOxUnits=**)
- 1.0942 = salinity (psu) (output if **OutputSal=Y**)
- 1492.642 = sound velocity (m/sec) (output if **OutputSV=Y**)
- 0.2 = specific conductivity ($\mu\text{S}/\text{cm}$) (output if **OutputSC=y**)
- 11 Oct 2013 = date
- 07:44:26 = time

These numbers should be reasonable; i.e., room temperature, zero conductivity, barometric pressure (gauge pressure), current date and time (shipped from the factory set to Pacific Daylight or Standard Time).

7. Command the MicroCAT to go to sleep (quiescent state) by typing **QS** and pressing the Enter key.

The MicroCAT is ready for programming and deployment.

Section 4:

Deploying and Operating MicroCAT

This section includes:

- system operation with example sets of operation commands
- baud rate and cable length considerations
- timeout description
- detailed command descriptions
- data output formats
- optimizing data quality / deployment orientation
- deploying and recovering the MicroCAT
- uploading and processing data from the MicroCAT's memory

Sampling Modes

Notes:

- The pump runs only if the conductivity frequency from the last sample was greater than the minimum conductivity frequency for running the pump (**MinCondFreq=**). Checking the conductivity frequency prevents the pump from running in air for long periods of time, which could damage the pump. See *Command Descriptions* for details on setting the minimum conductivity frequency.
- Autonomous sampling is not compatible with SDI-12 operation.

The MicroCAT has two basic sampling modes for obtaining data:

- Polled Sampling – On command, the MicroCAT runs the pump, takes one sample, and transmits data.
- Autonomous Sampling – At pre-programmed intervals, the MicroCAT wakes up, runs the pump, samples, stores data in memory, and goes to sleep. Data is transmitted real-time if **TxRealTime=Y**.

Commands can be used in various combinations to provide a high degree of operating flexibility.

The integral pump runs before every sample measurement. The pump flushes the previously sampled water from the conductivity cell and oxygen plenum and brings a new water sample quickly into the system. Water does not freely flow through the plumbing between samples, minimizing fouling. See *Pump Operation* in *Section 2: Description of MicroCAT* for details.

Descriptions and examples of the sampling modes follow. Note that the MicroCAT's response to each command is not shown in the examples. Review the operation of the basic sampling modes and the commands described in *Command Descriptions* before setting up your system.

Polled Sampling

On command, the MicroCAT takes a measurement and sends the data to the computer. Storing of data in the MicroCAT's FLASH memory is dependent on the particular command used.

For polled sampling commands that run the pump (**TPS**, **TPSH**, **TPSS**, **TPSN:x**, **SLTP**), the MicroCAT checks if the conductivity frequency from the last sample was greater than **MinCondFreq** before running the pump. Pumping time is dependent on the setting for **AdaptivePumpControl**, and on the temperature and pressure of the previous sample, as described in *Pump Operation* in *Section 2: Description of MicroCAT*.

Example: **Polled Sampling** (user input in bold)

Wake up MicroCAT. Set current date and time to December 1, 2012 9 am. Set up to send data in converted decimal format, and include temperature, conductivity, pressure, oxygen, and salinity with data. Command MicroCAT to run pump and take a sample, and send data to computer (do not store data in MicroCAT's memory). Send power-off command.

(Select *Connect* in Seaterm232's Communications menu to connect and wake up.)

DATE**TIME=12012012090000**

OUTPUTFORMAT=1

OUTPUTTEMP=Y

OUTPUTCOND=Y

OUTPUTPRESS=Y

OUTPUTOX=Y

OUTPUTSAL=Y

GETCD (to verify setup)

TPS (Pump runs before measurement if conductivity frequency from previous sample > **MinCondFreq**.)

QS

When ready to take a sample (repeat as desired): wake up MicroCAT, command it to take a sample and output data, and send power-off command.

(Before first sample, click Capture menu to capture data to a file – Seaterm232 requests file name for data to be stored.)

(Select *Connect* in Seaterm232's Communications menu to connect and wake up.)

TPS (Pump runs before measurement if conductivity frequency from previous sample > **MinCondFreq**.)

QS

Autonomous Sampling (Logging commands)

At pre-programmed intervals (**SampleInterval=**) the MicroCAT wakes up, runs the pump (if the conductivity frequency from the last sample was greater than **MinCondFreq=**), samples data, stores the data in its FLASH memory, and goes to sleep (enters quiescent state). Logging is started with **StartNow** or **StartLater**, and is stopped with **Stop**. Transmission of real-time data to the computer is dependent on **TxRealTime**. Pumping time is dependent on the setting for **AdaptivePumpControl=**, and on the temperature and pressure of the previous sample, as described in *Pump Operation* in *Section 2: Description of MicroCAT*.

Notes:

- Autonomous sampling is not compatible with SDI-12 operation.
- If the FLASH memory is filled to capacity, sampling continues, but excess data is not saved in memory (i.e., the MicroCAT does not overwrite the data in memory).
- Use **Stop** to:
 - stop logging.
 - stop waiting to start logging (after **StartLater** has been sent).
 Once **Stop** is sent, the MicroCAT will accept all commands again.

The MicroCAT has a *lockout* feature to prevent unintended interference with sampling. If the MicroCAT is logging or is waiting to start logging (**StartLater** has been sent, but logging has not started yet), the MicroCAT will only accept the following commands: **GetCD**, **GetSD**, **GetCC**, **GetEC**, **GetHD**, **DS**, **DC**, **TS**, **TSR**, **TPS**, **TPSH**, **SL**, **SLTP**, **QS**, and **Stop**.

Additionally, if the MicroCAT is logging, **it cannot be interrupted during a measurement** to accept any commands. If the MicroCAT is logging and appears unresponsive, it may be in the middle of taking a measurement; continue to try to establish communications.

If transmitting real-time data, keep the signal line open circuit or within ± 0.3 V relative to ground to minimize power consumption when not trying to send commands.

Example: Autonomous Sampling (user input in bold).

Wake up MicroCAT. Initialize logging to overwrite previous data in memory. Set current date and time to May 1, 2012 9 am. Set up to sample every 300 sec. Do not transmit real-time data to computer. Set up to automatically start logging on 10 May 2012 at 12:00:00. Send power-off command after all parameters are entered – system will automatically wake up and go to sleep for each sample.

(Select *Connect* in Seaterm232's Communications menu to connect and wake up.)

```
INITLOGGING
DATETIME=05012012090000
SAMPLEINTERVAL=300
TXREALTIME=N
STARTDATETIME=05102012120000
STARTLATER
GETCD      (to verify setup)
GETSD      (to verify status is not logging, start at . . .)
QS
```

After logging begins, look at data from last sample to check results, and then go to sleep:

(Select *Connect* in Seaterm232's Communications menu to connect and wake up.)

```
SL
QS
```

When ready to upload all data to computer, wake up MicroCAT, stop sampling, upload data, and then go to sleep:

(Select *Connect* in Seaterm232's Communications menu to connect and wake up.)

```
STOP
(Click Upload menu – Seaterm232 leads you through screens to define data to be uploaded and where to store it.)
QS
```

RS-232 Real-Time Data Acquisition

Notes:

- RS-232 Baud rate is set with **BaudRate=**. Set **TxRealTime=Y** to output real-time data for RS-232 communications. See *Command Descriptions*.
- If using external power, see *External Power* in *Section 2: Description of MicroCAT* for power limitations on cable length.

The length of cable that the MicroCAT can drive when communicating via **RS-232** is dependent on the baud rate. The allowable combinations are:

Maximum Cable Length (meters)	Maximum Baud Rate
200	4800
100	9600
50	19200
25	38400
16	57600
8	115200

Check the capability of your computer and terminal program before increasing the baud; high baud requires a short cable and good PC serial port with an accurate clock.

If acquiring real-time data with Seaterm232, click the Capture menu; enter the desired file name in the dialog box, and click Save. Begin sampling. The data displayed in Seaterm232 will be saved to the designated file. Process the data as desired. Note that this file **cannot be processed by SBE Data Processing, as it does not have the required headers and format for Sea-Bird's processing software**. To process data with SBE Data Processing, upload the data from the MicroCAT's memory

Timeout Description

The MicroCAT has a timeout algorithm. If the MicroCAT does not receive a command for 2 minutes, it powers down its communication circuits to prevent exhaustion of the battery pack. This places the MicroCAT in quiescent state, drawing minimal current. **To re-establish control (wake up), select *Connect* in Seaterm232's Communications menu or press the Enter key.**

Command Descriptions – Transmission via RS-232

This section describes all commands that can be sent to the MicroCAT via RS-232, and provides sample outputs. Entries made with the commands are permanently stored in the MicroCAT and remain in effect until you change them. See *Appendix III: Command Summary* for a summarized command list.

When entering commands:

- Input commands to the MicroCAT in upper or lower case letters and register commands by pressing the Enter key. Note that commands are shown with a mix of upper and lower case for ease in reading (for example, **MinCondFreq=**), but do not need to be entered that way.
- The MicroCAT sends an error message if an invalid command is entered.
- Commands to enable a parameter (such as enabling adaptive pump control) can be entered with the *argument* as Y or 1 for yes, and N or 0 for no (for example, **AdaptivePumpControl=y** and **AdaptivePumpControl=1** are equivalent; both enable adaptive pump control).
- If a new command is not received within 2 minutes after the completion of a command, the MicroCAT returns to the quiescent (sleep) state.
- If in quiescent (sleep) state, re-establish communications by selecting *Connect* in Seaterm232's Communications menu or pressing the Enter key.
- If the MicroCAT is transmitting data and you want to stop it, press the Esc key or type ^C. Then press the Enter key. Alternatively, select *Abort* in Seaterm232's Command menu.
- The MicroCAT responds only to **GetCD**, **GetSD**, **GetCC**, **GetEC**, **GetHD**, **DS**, **DC**, **TS**, **TSR**, **TPS**, **TPSH**, **SL**, **SLTP**, **QS**, and **Stop** while sampling autonomously (**StartNow** has been sent). If you wake the MicroCAT while it is pumping or sampling (for example, to send **DS** to check on progress):
 - (if **OutputExecutedTag=Y**) The MicroCAT responds with one or more `<Executing>` tags until the sample is complete, and then responds to the command.
 - (if **OutputExecutedTag=N**) The MicroCAT responds to the command after the sample is complete.
- The MicroCAT responds only to **GetCD**, **GetSD**, **GetCC**, **GetEC**, **GetHD**, **DS**, **DC**, **TS**, **TSR**, **TPS**, **TPSH**, **SL**, **SLTP**, **QS**, and **Stop** while waiting to start autonomous sampling (**StartLater** has been sent). To send any other commands, send **Stop**, send the desired commands to modify the setup, and then send **StartLater** again.

Status Commands

Notes:

- **GetCD** output does not include calibration coefficients. To display calibration coefficients, use the **GetCC** command.
- Lines describing what parameters to output (temperature, conductivity, pressure, oxygen, salinity, sound velocity, specific conductivity, sample number) only appear if **OutputFormat=1, 2, or 3**. Raw output (**OutputFormat=0**) is not affected by enabling / disabling parameter outputs.

GetCD

Get and display configuration data, which includes parameters related to MicroCAT setup. Most of these parameters can be user-input/modified. List below includes, where applicable, command used to modify parameter:

- Device type, Serial number
- Pressure sensor installed?
- Reference pressure (dbar) to use in calculations if no pressure sensor installed (only sent if pressure not installed) [**ReferencePressure=**]
- Output data format [**OutputFormat=**]
- Units for:
 - temperature [**SetTempUnits=**],
 - conductivity and specific conductivity [**SetCondUnits=**],
 - pressure [**SetPressUnits=**],
 - oxygen [**SetOxUnits=**]
- Output with each sample:
 - temperature [**OutputTemp=**]?
 - conductivity [**OutputCond=**]?
 - pressure [**OutputPress=**]?
 - oxygen [**OutputOx=**]?
 - salinity [**OutputSal=**]?
 - sound velocity [**OutputSV=**]?
 - specific conductivity [**OutputSC=**]?
- Specific conductivity temperature coefficient [**UseSCDefault=** and **SetSCA=**]
- Output sample number with real-time autonomous data and polled data from memory [**TxSampleNum=**]?
- Interval between samples for autonomous sampling [**SampleInterval=**]
- Transmit autonomous data real-time [**TxRealTime=**]?
- Minimum conductivity frequency for pump turn-on [**MinCondFreq=**]
- Adaptive pump control enabled [**AdaptivePumpControl=**]?
- Pump time multiplier [**OxNTau=**].
- Pump-on time for each measurement [**OxNTau * OxTau20**] if Adaptive Pump Control disabled. Only sent if Adaptive Pump Control disabled.
- SDI-12 address [**SetAddress=**]
- Out of range value for **OutputFormat=3** and SDI-12 communications [**SetSDI12Flag=**]

Example: MicroCAT with a pressure sensor (user input in bold, command used to modify parameter in parentheses).

GETCD

```

<ConfigurationData DeviceType = 'SBE37SMP-ODO-SDI12' SerialNumber = '03710103'>
  <PressureInstalled>yes</PressureInstalled>                (inclusion of pressure sensor set at factory)
  <SampleDataFormat>converted engineering</SampleDataFormat> [OutputFormat=]
  <TemperatureUnits>Celsius</TemperatureUnits>             [SetTempUnits=]
  <ConductivityUnits>µS/m</ConductivityUnits>               [SetCondUnits=]
  <PressureUnits>PSI</PressureUnits>                        [SetPressUnits=]
  <OxygenUnits>mg/L</OxygenUnits>                            [SetOxUnits=]
  <OutputTemperature>yes</OutputTemperature>                [OutputTemp=]
  <OutputConductivity>yes</OutputConductivity>              [OutputCond=]
  <OutputPressure>yes</OutputPressure>                       [OutputPress=]
  <OutputOxygen>yes</OutputOxygen>                           [OutputOx=]
  <OutputSalinity>yes</OutputSalinity>                       [OutputSal=]
  <OutputSV>yes</OutputSV>                                   [OutputSV=]
  <OutputSC>yes</OutputSC>                                   [OutputSC=]
  <SCCoeff>0.0200</SCCoeff>                                  [UseSCDefault= and SetSCA=]
  <TxSampleNumber>yes</TxSampleNumber>                       [TxSampleNum=]
  <SampleInterval>300</SampleInterval>                       [SampleInterval=]
  <TxRealTime>yes</SampleInterval>                           [TxRealTime=]
  <MinCondFreq>3224.1</MinCondFreq>                         [MinCondFreq=]
  <AdaptivePumpControl>yes</AdaptivePumpControl>            [AdaptivePumpControl=]
  <nTau>7.0</nTau>                                           [OxNTau=]
  <SDI12Address>0</SDI12Address>                             [SetAddress=]
  <SDI12Flag>+9999999</SDI12Flag>                           [SetSDI12Flag=]
</ConfigurationData>

```

Status Commands (*continued*)**GetSD**

Get and display status data, which contains data that changes while deployed.

List below includes, where applicable, command used to modify parameter:

- Device type, Serial number
- Date and time [**DateTime=**] in ISO8601-2000 extended format (yyyy – mm-ddThh:mm:ss)
- Number of recorded events in event counter [reset with **ResetEC**]
- Voltages – main battery pack voltage and back-up lithium cell voltage
- Memory – [reset with **InitLogging**]
 - Number of bytes in memory
 - Number of samples in memory
 - Number of additional samples that can be placed in memory
 - Length (number of bytes) of each sample
- Logging status –
 - yes or no (to indicate whether it is currently logging data);
 - if applicable, reason that logging has stopped

Example: (user input in bold, command used to modify parameter in parentheses)

getsd

```

<StatusData DeviceType = 'SBE37SMP-ODO-SDI12' SerialNumber = ' 03712345'>
  <DateTime>2012-11-02T00:48:32</DateTime>                                [DateTime=]
  <EventSummary numEvents = '0' />                                       [can clear with ResetEC=]
  <Power>
    <vMain> 13.32</vMain>
    <vLith> 3.19</vLith>
  </Power>
  <MemorySummary>
    <Bytes>3612</Bytes>
    <Samples>172</Samples>                                               [can clear with InitLogging]
    <SamplesFree>399285</SamplesFree>                                     [can clear with InitLogging]
    <SampleLength>21</SampleLength>
  </MemorySummary>
  <AutonomousSampling>no, stop command</AutonomousSampling>          [StartNow or StartLater, Stop]
</StatusData>

```

Status Commands (*continued*)**Note:**

Dates shown are when calibrations were performed.

GetCC

Get and display calibration coefficients, which are initially factory-set and should agree with Calibration Certificates shipped with MicroCAT.

Example: MicroCAT with a pressure sensor (user input in bold, command used to modify parameter in parentheses)

getcc

```

<CalibrationCoefficients DeviceType = 'SBE37SMP-ODO-SDI12' SerialNumber = '03712345'>
  <Calibration format = 'TEMP1' id = 'Temperature'>
    <SerialNum>03712345</SerialNum>
    <CalDate>04-Aug-12</CalDate> [TCalDate=]
    <A0>6.947802e-05</A0> [TA0=]
    <A1>2.615233e-04</A1> [TA1=]
    <A2>-1.265233e-06</A2> [TA2=]
    <A3>1.310479e-07</A3> [TA3=]
  </Calibration>
  <Calibration format = 'WBCOND0' id = 'Conductivity'>
    <SerialNum>03712345</SerialNum>
    <CalDate>04-Oct-12</CalDate> [CCalDate=]
    <G>-1.009121e+00</G> [CG=]
    <H>1.410162e-01</H> [CH=]
    <I>-2.093167e-04</I> [CI=]
    <J>3.637053e-05</J> [CJ=]
    <PCOR>-9.570000e-08</PCOR> [CTCor=]
    <TCOR>3.250000e-06</TCOR> [CPCor=]
    <WBOTC>1.954800e-05</WBOTC> [CWBOTC=]
  </Calibration>
  <Calibration format = 'STRAIN0' id = 'Pressure'>
    <SerialNum>2478619</SerialNum>
    <CalDate>28-Oct-12</CalDate> [PCalDate=]
    <PA0>1.729067e+00</PA0> [PA0=]
    <PA1>1.415754e-01</PA1> [PA1=]
    <PA2>1.246912e-08</PA2> [PA2=]
    <PTCA0>2.243971e+00</PTCA0> [PTCA0=]
    <PTCA1>1.055267e+00</PTCA1> [PTCA1=]
    <PTCA2>-2.276308e-02</PTCA2> [PTCA2=]
    <PTCB0>1.003849e+02</PTCB0> [PTCB0=]
    <PTCB1>1.014510e-02</PTCB1> [PTCB1=]
    <PTCB2>-2.057110e-04</PTCB2> [PTCB2=]
    <PTempa0>5.669780e+01</PTempa0> [PTempa0=]
    <PTempa1>-5.474043e-02</PTempa1> [PTempa1=]
    <PTempa2>1.267908e-05</PTempa2> [PTempa2=]
    <POFFSET>0.000000e+00</POFFSET> [POffset= (decibars)]
    <PRANGE>0.000000e+00</PRANGE> [PRange= (psi)]
  </Calibration>
  <Calibration format = 'OXYGEN1' id = 'Oxygen'>
    <SerialNum>12</SerialNum>
    <CalDate>28-Jul-12</CalDate> [OxCalDate=]
    <TAU20>4.000000e+00</TAU20> [OxTau20=]
    <NTAU>7.000000e+00</NTAU> [OxNTau=]
    <OXA0>1.051300e+00</OXA0> [OxA0=]
    <OXA1>-1.500000e-03</OXA1> [OxA1=]
    <OXA2>4.161926e-01</OXA2> [OxA2=]
    <OXB0>-2.325492e-01</OXB0> [OxB0=]
    <OXB1>1.692931e+00</OXB1> [OxB1=]
    <OXC0>8.966704e-02</OXC0> [OxC0=]
    <OXC1>3.617471e-03</OXC1> [OxC1=]
    <OXC2>5.112384e-05</OXC2> [OxC2=]
    <OXTA0>6.517293e-04</OXTA0> [OxTA0=]
    <OXTA1>2.533749e-04</OXTA1> [OxTA1=]
    <OXTA2>3.140482e-07</OXTA2> [OxTA2=]
    <OXTA3>1.064506e-07</OXTA3> [OxTA3=]
    <OXE>1.100000e-02</OXE> [OxE=]
  </Calibration>
</CalibrationCoefficients>

```

Status Commands (*continued*)**GetEC**

Get and display event counter data, which can help to identify root cause of a malfunction. Event counter records number of occurrences of common timeouts, power-on resets, etc. Can be cleared with **ResetEC**. Possible events that may be logged include:

- WDT reset – unexpected reset
- PON reset - power cycled on (each time power is applied)
- ErrorADC12TimeOut – response delayed from A/D converter that measures main power and back-up lithium cell power
- ErrorUART0TimeOut – timeout for transmitter to finish transmitting previous character via RS-232
- ErrorAD7714TimeOut – response delayed from temperature and pressure A/D converter
- ErrorInvWakeUpFlag – unexpected wakeup
- ErrorFLASHTimeOut – problem with writing data to FLASH memory
- Alarm long - time to take next sample is too far in future
- Alarm short - woke up MicroCAT to send a command while logging, and missed taking a sample
- LoggingRestartNoAlarm – no sample taken for 8 hours while logging, restart logging
- LoggingRestartPON – power cycled while logging, logging restarted
- ErrorSBE63Timeout – SBE 63 not responding within 1.5 sec of when power applied by MicroCAT

Example: (user input in bold, command used to modify parameter in parentheses)

getec

```
<EventCounters DeviceType = 'SBE37SMP-ODO-SDI12' SerialNumber = '03712345'>
  <EventSummary numEvents = '1' /> [can clear with ResetEC]
  <Event type = 'PON reset' count = '1' /> [can clear with ResetEC]
</EventCounters>
```

ResetEC

Delete all events in event counter (number of events displays in **GetSD** response, and event details display in **GetEC** response).

Status Commands (*continued*)**GetHD**

Get and display hardware data, which is fixed data describing MicroCAT:

- Device type, Serial number
- Manufacturer
- Firmware version
- Firmware date
- PCB serial numbers and assembly numbers
- Manufacture date
- Sensor types and serial numbers

Example: (user input in bold, command used to modify parameter in parentheses)

gethd

```
<HardwareData DeviceType='SBE37SMP-ODO-SDI12' SerialNumber='03710663'>
  <Manufacturer>Sea-Bird Electronics, Inc.</Manufacturer>
  <FirmwareVersion>2.4.2</FirmwareVersion>
  <FirmwareDate>30 Sep 2013 15:59:47</FirmwareDate>
  <CommandSetVersion>1.1</CommandSetVersion>
  <PCBAssembly SerialNum='51390' AssemblyNum='41783C' />
  <PCBAssembly SerialNum='56651' AssemblyNum='41785B' />
  <PCBAssembly SerialNum='56805' AssemblyNum='41661B' />
  <PCBAssembly SerialNum='51434' AssemblyNum='41787C' />
  <MfgDate>10-Oct-2013</MfgDate>
  <FirmwareLoader>SBE 37-232-V3 FirmwareLoader V 1.0</FirmwareLoader>
  <InternalSensors>
    <Sensor id='Temperature'>
      <type>temperature-1</type>
      <SerialNumber>03710663</SerialNumber>
    </Sensor>
    <Sensor id='Conductivity'>
      <type>conductivity-1</type>
      <SerialNumber>03710663</SerialNumber>
    </Sensor>
    <Sensor id='Pressure'>
      <type>strain-0</type>
      <SerialNumber>3811790</SerialNumber>
    </Sensor>
    <Sensor id='Oxygen'>
      <type>oxygen-1</type>
      <SerialNumber>0439</SerialNumber>
    </Sensor>
  </InternalSensors>
</HardwareData>
```

Help

Display list of currently available commands, which may be useful if you do not have access to the MicroCAT manual and/or are not using SeatermV2. Command list depends on logging state. Many commands are not available while MicroCAT is sampling autonomously or waiting to start autonomous sampling (**StartLater** has been sent).

Status Commands (*continued*)**Notes:**

- The **DS** response contains similar information as the combined responses from **GetSD** and **GetCD**, but in a different format.
- Lines describing what parameters to output (temperature, conductivity, pressure, oxygen, salinity, sound velocity, specific conductivity, sample number) only appear if they are enabled, and if **OutputFormat=1, 2, or 3**. Raw output (**OutputFormat=0**) is not affected by enabling / disabling parameter outputs.
- The **DS** response is also affected by the **Legacy=** command. See the Output Format Setup commands below.

DS

Display operating status and setup.

List below includes, where applicable, command used to modify parameter.

- Firmware version, serial number, date and time [**DateTime=**].
- Main battery pack voltage and back-up lithium cell voltage.
- Number of samples in memory [**SampleNumber=**] and available sample space in memory.
- Logging status (logging not started, logging data, not logging, or unknown).
- Interval between samples for autonomous sampling [**SampleInterval=**].
- Output data format [**OutputFormat=**].
- Output temperature [**OutputTemp=**]? Temperature units [**SetTempUnits=**]
- Output conductivity [**OutputCond=**]? Conductivity and specific conductivity units [**SetCondUnits=**]
- Output pressure [**OutputPress=**]? Pressure units [**SetPressUnits=**]
- Output oxygen [**OutputOx=**]? Oxygen units [**SetOxUnits=**]
- Output salinity [**OutputSal=**]? Factory-set salinity units (psu)
- Output sound velocity [**OutputSV=**]? Factory-set sound velocity units (m/s)
- Output specific conductivity [**OutputSC=**]? Conductivity and specific conductivity units [**SetCondUnits=**]
- Specific conductivity temperature coefficient [**UseSCDefault=** and **SetSCA=**]
- Transmit sample number with real-time autonomous data and polled data from memory [**TxSampleNum=**]?
- Transmit autonomous data real-time [**TxRealTime=**]?
- Reference pressure to use in calculations if no pressure sensor installed (only sent if pressure sensor not installed) [**ReferencePressure=**].
- Minimum conductivity frequency for pump turn-on [**MinCondFreq=**].
- Adaptive pump control enabled [**AdaptivePumpControl=**]? If not enabled, pump-on time for each measurement displays [**OxNTau * OxTau20**].
- Pump time multiplier [**OxNTau=**]
- SDI-12 address [**SetAddress=**].
- Out of range value for **OutputFormat=3** and SDI-12 communications [**SetSDI12Flag=**]

Example: MicroCAT with a pressure sensor (user input in bold, command used to modify parameter in parentheses).

DS

SBE37SMP-ODO-SDI12 V 2.4.2 SERIAL NO. 12345 11 Oct 2013 10:55:45	[DateTime=]
vMain = 13.31, vLith = 3.19	
samplenum = 0, free = 399457	[SampleNumber=]
not logging, stop command	
sample interval = 300 seconds	[SampleInterval=]
data format = converted engineering	[OutputFormat=]
output temperature, Celsius	[OutputTemp=, SetTempUnits=]
output conductivity, μ S/m	[OutputCond=, SetCondUnits=]
output pressure, PSI	[OutputPress=, SetPressUnits=]
output oxygen, mg/L	[OutputOx=, SetOxUnits=]
output salinity, PSU	[OutputSal=, factory-set units]
output sound velocity, m/s	[OutputSV=, factory-set units]
output specific conductivity, μ S/m	[OutputSC=, SetCondUnits=]
user defined specific conductivity coefficient = 0.0200	[UseSCDefault= and SetSCA=]
output sample number	[TxSampleNum=]
transmit real time data = yes	[TxRealTime=]
minimum conductivity frequency = 3000.00	[MinCondFreq=]
adaptive pump control enabled	[AdaptivePumpControl=]
nTau = 7.0	[OxNTau=]
SDI-12 address = 0	[SetAddress=]
SDI-12 flag = +9999999	[SetSDI12Flag=]

Notes:

- The **DC** and **GetCC** responses contain the same information, but in different formats.
- Dates shown are when calibrations were performed.

Status Commands (*continued*)**DC**

Display calibration coefficients, which are initially factory-set and should agree with Calibration Certificates shipped with MicroCAT.

Example: MicroCAT with a pressure sensor (user input in bold, command used to modify parameter in parentheses).

DC

```

SBE37SMP-ODO-SDI12 V 2.4.2 12345
temperature: 04-Aug-13 [TCalDate=]
TA0 = 6.947802e-05 [TA0=]
TA1 = 2.615233e-04 [TA1=]
TA2 = -1.265233e-06 [TA2=]
TA3 = 1.310479e-07 [TA3=]
conductivity: 04-Aug-13 [CCalDate=]
G = -1.036689e+00 [CG=]
H = 1.444342e-01 [CH=]
I = -3.112137e-04 [CI=]
J = 3.005941e-05 [CJ=]
CPCOR = -9.570001e-08 [CPCor=]
CTCOR = 3.250000e-06 [CTCor=]
WBOTC = 1.968100e-05 [CWBOTC=]
pressure S/N 2478619, range = 2901 psia, 03-Aug-13 [PRange= (psi), PCalDate=]
  PA0 = 0.000000e+00 [PA0=]
  PA1 = 0.000000e+00 [PA1=]
  PA2 = 0.000000e+00 [PA2=]
  PTCA0 = 0.000000e+00 [PTCA0=]
  PTCA1 = 0.000000e+00 [PTCA1=]
  PTCA2 = 0.000000e+00 [PTCA2=]
  PTCB0 = 0.000000e+00 [PTCB0=]
  PTCB1 = 0.000000e+00 [PTCB1=]
  PTCB2 = 0.000000e+00 [PTCB2=]
  PTEMPA0 = 0.000000e+00 [PTempA0=]
  PTEMPA1 = 0.000000e+00 [PTempA1=]
  PTEMPA2 = 0.000000e+00 [PTempA2=]
  POFFSET = 0.000000e+00 [POffset= (decibars)]
oxygen S/N 12, 28-Aug-13 [OxCalDate=]
TAU_20 = 4.000000e+00 [OxTau20=]
OXA0 = 1.051300e+00 [OxA0=]
OXA1 = -1.500000e-03 [OxA1=]
OXA2 = 4.161926e-01 [OxA2=]
OXB0 = -2.325492e-01 [OxB0=]
OXB1 = 1.692931e+00 [OxB1=]
OXC0 = 8.966704e-02 [OxC0=]
OXC1 = 3.617471e-03 [OxC1=]
OXC2 = 5.112384e-05 [OxC2=]
OXTA0 = 6.517293e-04 [OxTA0=]
OXTA1 = 2.533749e-04 [OxTA1=]
OXTA2 = 3.140482e-07 [OxTA2=]
OXTA3 = 1.064506e-07 [OxTA3=]
OXE = 1.100000e-02 [OxE=]

```

General Setup Commands

DateTime=mmddyyhhmmss Set real-time clock month, day, year, hour, minute, second.

Example: Set current date and time to 10 November 2012 12:00:00 (user input in bold).
DATE TIME=11102012120000

Notes:

- The MicroCAT baud rate (set with **BaudRate=**) must be the same as Seaterm232's baud rate (set in the Communications menu).
- **BaudRate=** must be sent twice. After the first entry, the MicroCAT changes to the new baud, and then waits for the command to be sent again at the new baud (In Seaterm232's Communications menu, select *Configure*. In the dialog box, select the new baud rate and click OK. Then retype the command.). This prevents you from accidentally changing to a baud that is not supported by your computer. If it does not receive the command again at the new baud, it reverts to the previous baud rate.

BaudRate=x

x = baud rate for **RS-232** communication (4800, 9600, 19200, 38400, 57600, or 115200). Default 9600. Check capability of your computer and terminal program before increasing baud; high baud requires a short cable and good PC serial port with accurate clock. **Command must be sent twice to change rate.**

Length of cable that MicroCAT can drive for RS-232 communication is dependent on baud. See *Real-Time Data Acquisition*.

Note: 1200 baud is used for SDI-12 communication, and is independent of baud set for RS-232 communication.

ReferencePressure=x

x = reference pressure (gauge) in decibars. MicroCAT without pressure sensor uses this pressure in conductivity (and optional salinity, sound velocity, and specific conductivity) calculations, and in *Adaptive Pump Control* algorithm (if enabled). Entry ignored if pressure sensor installed.

Note:

The MicroCAT automatically enters quiescent state after 2 minutes without receiving a command. This timeout algorithm is designed to conserve battery pack energy if the user does not send **QS** to put the MicroCAT to sleep.

QS

Quit session and place MicroCAT in quiescent (sleep) state. Main power is turned off. Data logging and memory retention are not affected.

RS-232 Setup Commands

These commands are not applicable for SDI-12 communications. Executed tags and real-time autonomous sampling data are never output for SDI-12 communications.

OutputExecutedTag=x **x=Y:** Display XML Executing and Executed tags for **RS-232** communications. Executed tag displays at end of each command response; Executing tag displays one or more times if MicroCAT response to command requires additional time.

x=N: Do not.

Example: Set to output Executed and Executing tags (user input in bold).

```
outputexecutedtag=y
<Executed/>getcd
. . . (GetCD response)
<Executed/>
(Note: <Executed/> tag at end of command response takes place of S> prompt.)
```

Notes:

- The MicroCAT always outputs real-time data for polled sampling.
- **TxRealTime=** does not affect storing data to memory, but slightly increases current consumption and time needed to sample (and then transmit) data.
- To capture real-time data to a file, do the following *before* starting logging:
 1. Click the Capture menu in Seaterm232.
 2. Enter the desired file name in the dialog box. The *capture* status displays in the status bar at the bottom of the screen.

TxRealTime=x **x=Y:** Output real-time data for **RS-232** communications while sampling autonomously. Data is transmitted immediately after it is sampled.

x=N: Do not output real-time data.

SDI-12 Setup Commands

SetAddress=x **x=** address (0-9, a-z, A-Z) for **SDI-12** communications. **Command must be sent twice to change address.**

SetSDI12Flag=x **x=** out-of-range value (-9999999 to +9999999; must include + or - sign) for **SDI-12** communications (**OutputFormat=3**). **Default +9999999**. If MicroCAT calculates data that is out of range for a particular parameter, this value is inserted in data stream for that parameter.

Out-of-range value is not applicable if **OutputFormat=0, 1, or 2**; it is factory set to *nan*.

Pump Setup Commands

Note:

See *Pump Operation* in *Section 2: Description of MicroCAT* for details.

The MicroCAT's integral pump is water lubricated; running it *dry* for an extended period of time will damage it. To prevent the pump from running dry while sampling, the MicroCAT checks the raw conductivity frequency (Hz) from the last sample against the user-input minimum conductivity frequency (**MinCondFreq**). If the raw conductivity frequency is greater than **MinCondFreq**, it runs the pump before taking the sample; otherwise it does not run the pump.

If the minimum conductivity frequency is too close to the *zero conductivity frequency* (from the MicroCAT Calibration Sheet), the pump may turn on when the MicroCAT is in air, as a result of small drifts in the electronics. Some experimentation may be required to control the pump, particularly in fresh water applications.

MinCondFreq=x

x= minimum conductivity frequency (Hz) to enable pump turn-on, to prevent pump from running before MicroCAT is in water. Pump does not run when conductivity frequency drops below **MinCondFreq**. MicroCAT Configuration Sheet lists uncorrected (raw) frequency output at 0 conductivity.

Typical value (and factory-set default) for salt water and estuarine applications:
(zero conductivity frequency + 500 Hz).

Typical value for fresh water applications:
(zero conductivity frequency + 5 Hz).

Note:

OxTau20 is the SBE 63 ODO sensor response time. If Adaptive Pump Control is turned off, the pump runs for a multiple [**OxNTau**] of the response time before each sample.

AdaptivePumpControl=x

x=Y: Run pump before each sample based on *Adaptive Pump Control*. Run pump for **OxNTau * OxTau20 * ft * fp**. **Default**.

x=N: Do not use *Adaptive Pump Control*; run pump for [**OxNTau * OxTau20**] before each sample. **Adaptive Pump Control should be disabled only for testing and calibration.**

Example: If **AdaptivePumpControl=N**, **OxTau20=4.0** (sec), and **OxNTau=7.0**, pump will run for 28 sec (= 7.0 * 4.0) before each sample.

OxNTau=x

x= pump time multiplier.
Range 1 – 100; **default 7**.

CAUTION:

The MicroCAT does not check **MinCondFreq** when you send **PumpOn**; **do not run the pump dry**. The pump is water lubricated; running it without water will damage it. If briefly testing your system with **PumpOn** in dry conditions, orient the MicroCAT to provide an upright U-shape for the plumbing. Then fill the internal plumbing and inside of the pump head with water via the pump exhaust. This will provide enough lubrication to prevent pump damage during brief testing.

PumpOn

Turn pump on to test pump or remove sediment from inside plumbing. **Pump runs continuously, drawing current**. Send **PumpOff** to stop. **PumpOn** has no effect on pump operation while sampling.

PumpOff

Turn pump off if it was turned on with **PumpOn**. **PumpOff** has no effect on pump operation while sampling.

SBE 63 Optical Dissolved Oxygen Sensor Setup Commands

Note:
 When using the SBE 63 integrated with a MicroCAT, the following setup in the **SBE 63** is required:

- **SetBaud=2400** (factory set; cannot be changed by command through the MicroCAT).
- **SetEcho=1.**
- **SetFormat=1.**
- **SetAvg=1 to 16; recommended value is 2.**
- **SetAutoRun=0.**
- <TxPwrSave> in SBE 63's **GetSD** or **GetHD** response is 0 (factory set; cannot be changed by command).

Send63=command Command MicroCAT to send **command** to SBE 63 and receive response; **command** can be any command recognized by SBE 63.

```

Example: Send GetSD command to SBE 63 to verify its setup (user input in bold).
send63=getsd
Sending SBE63: getsd
-----
getsd
<StatusData DeviceType = 'SBE063' SerialNumber = '0012'>
  <FirmwareVersion>V0.9n 05Dec2011</FirmwareVersion>
  <LoaderVersion>SBE 63 FirmwareLoader V 1.0</LoaderVersion>
  <CalibrationDate>04150</CalibrationDate>
  <StatusConfig>
    <BaudRate>002400</BaudRate>
    <BlueOnTime>0000001</BlueOnTime>
    <SampleAvg>002</SampleAvg>
    <SampleInterval>00002</SampleInterval>
    <BootDelay>001</BootDelay>
    <OutFormat>01</OutFormat>
    <AnalogGain>2</AnalogGain>
    <AnalogOffset>06</AnalogOffset>
    <Autorun>0</Autorun>
    <BlueTupdate>0</BlueTupdate>
    <Flags>0x0000</Flags>
  </StatusConfig>
</StatusData>
<Executed/>
    
```

Commands that can be sent to the SBE 63 that are applicable to its use when integrated with the MicroCAT are listed below with brief descriptions; see the SBE 63 manual for details.

- GetSD** Get and display SBE 63 status data.
- GetHD** Get and display SBE 63 hardware data.
- GetCC** Get and display SBE 63 calibration coefficients
- SetBaud=2400** Required SBE 63 setting for use with MicroCAT.
- SetFormat=1** Required SBE 63 setting for use with MicroCAT.
- SetAvg=x** x= number of measurements in SBE 63 to average per sample; each measurement takes approximately 0.03 sec. Increasing **SetAvg=** may shorten sensor film life. **Required range for use with MicroCAT is 1-16; recommended value 2.**
- SetAutoRun=0** Required SBE 63 setting for use with MicroCAT.
- *Default** Reset most SBE 63 Setup parameters to factory defaults. Note that baud (**SetBaud=**) is **not** reset.
- TS** Take **1** SBE 63 sample, transmit data in format defined by SBE 63's **SetFormat=**.
- TSR** Take **1** SBE 63 sample, transmit data in raw format (for factory diagnostics).

Notes:

- The MicroCAT pump does not run when **TS** or **TSR** is sent to the SBE 63. If desired, use **PumpOn** and **PumpOff** to turn the pump on and off.
- **Converted data in the SBE 63 response to TS is based on the calibration coefficients programmed into the SBE 63, not the oxygen sensor calibration coefficients programmed into the MicroCAT.**

Notes:

- If the FLASH memory is filled to capacity, sampling continues, but excess data is not saved in memory (i.e., the MicroCAT does not overwrite data in memory).
- The MicroCAT requires verification when **InitLogging** or **SampleNumber=** are sent. It responds with a request to repeat the command to confirm. Type the command again and press the Enter key to proceed.
- **Do not send InitLogging or SampleNumber=0 until all data has been uploaded.** These commands do not delete data; they just reset the data pointer. **If you accidentally send one of these commands before uploading,** recover the data as follows:
 1. Set **SampleNumber=x**, where **x** is your estimate of number of samples in memory.
 2. Upload data. If **x** is more than actual number of samples in memory, data for non-existent samples will be bad, random data. Review uploaded data file carefully and delete any bad data.
 3. If desired, increase **x** and upload data again, to see if there is additional valid data in memory.

Memory Setup Commands**InitLogging**

Initialize logging – after all previous data has been uploaded, initialize logging before starting to sample again to make entire memory available for recording.

InitLogging sets sample number (**SampleNumber=**) to 0 (sampling will start with sample 1). If not set to 0, data will be stored after last recorded sample.

Do not send InitLogging until all existing data has been uploaded.

MicroCAT requires this command to be sent twice, to prevent accidental reset of memory.

SampleNumber=x

x= sample number for last sample in memory. **SampleNumber=0** is equivalent to **InitLogging**. **Do not send SampleNumber=0 until all existing data has been uploaded.**

MicroCAT requires this command to be sent twice, to prevent accidental reset of memory.

Output Format Setup Commands

Notes:

- See *Data Formats* after the command descriptions.
- The MicroCAT does not *store* salinity, sound velocity, or specific conductivity in memory when they are enabled. It calculates and outputs these derived parameters in real-time, when polled for data or as data is uploaded; therefore, outputting these parameters has no effect on the number of samples that can be stored in memory.
- Salinity, sound velocity, and specific conductivity (as well as other parameters, such as density) can also be calculated in SBE Data Processing, from data uploaded from the MicroCAT's memory.
- The pressure sensor is an absolute sensor, so its **raw** output (**OutputFormat=0**) includes the effect of atmospheric pressure (14.7 psi). However, when outputting pressure in **psi** or **decibars**, the MicroCAT outputs pressure relative to the ocean surface (i.e., at the surface the output pressure is 0 psi or 0 dbar). The MicroCAT uses the following equations to convert psia:

$$P(\text{psi}) = P(\text{psia}) - 14.7$$

$$P(\text{dbar}) = [P(\text{psia}) - 14.7] * 0.689476$$

OutputFormat=x	<p>x=0: output raw decimal data.</p> <p>x=1: output converted decimal data.</p> <p>x=2: output converted decimal XML data.</p> <p>x=3: output converted decimal data in format compatible with SDI-12. Note: MicroCAT automatically outputs over SDI-12 line in this format; setting OutputFormat=3 allows you to view this data format while communicating via RS-232.</p>
OutputTemp=x	<p>x=Y: Output temperature (units defined by SetTempUnits=) with each sample if OutputFormat=1, 2, or 3.</p> <p>x=N: Do not.</p>
SetTempUnits=x	<p>x=0: Temperature output °C, ITS-90.</p> <p>x=1: Temperature output °F, ITS-90.</p>
OutputCond=x	<p>x=Y: Output conductivity (units defined by SetCondUnits=) with each sample if OutputFormat=1, 2, or 3.</p> <p>x=N: Do not.</p>
SetCondUnits=x	<p>x=0: Conductivity and specific conductivity output S/m.</p> <p>x=1: Conductivity and specific conductivity output mS/cm.</p> <p>2: Conductivity and specific conductivity output µS/cm.</p>
OutputPress=x	<p>x=Y: Output pressure (units defined by SetPressUnits=) with each sample if OutputFormat=1, 2, or 3.</p> <p>x=N: Do not.</p>
SetPressUnits=x	<p>x=0: Pressure output decibars.</p> <p>x=1: Pressure output psi (gauge).</p>
OutputOx=x	<p>x=Y: Output oxygen (units defined by SetOxUnits=) with each sample if OutputFormat=1, 2, or 3.</p> <p>x=N: Do not.</p>
SetOxUnits=x	<p>x=0: Oxygen output ml/L.</p> <p>x=1: Oxygen output mg/L.</p>
OutputSal=x	<p>x=Y: Output salinity (psu) with each sample if OutputFormat=1, 2, or 3.</p> <p>x=N: Do not.</p>

Output Format Setup Commands (*continued*)

OutputSV=x

x=Y: Output sound velocity (m/sec) using Chen and Millero formula (UNESCO Technical Papers in Marine Science #44) with each sample, if **OutputFormat=1, 2, or 3**.

x=N: Do not.

OutputSC=x

x=Y: Output specific conductivity (units defined by **SetCondUnits=**) with each sample, if **OutputFormat=1, 2, or 3**.

x=N: Do not.

UseSCDefault=x

*Only applicable if **OutputSC=Y**.*

x=0: Use value specified by **SetSCA=**.

x=1: Use default value of 0.020 for thermal coefficient of conductivity for natural salt ion solutions (used in specific conductivity calculation).

SetSCA=x

*Only applicable if **OutputSC=Y** and **UseSCDefault=0**.*

x= thermal coefficient of conductivity for natural salt ion solutions (used in specific conductivity calculation).

TxSampleNum=x

x=Y: Output sample number with each *polled* sample if **OutputFormat=1, 2, or 3**.

x=N: Do not.

SetCoastal=x

x=0: Reset output units to °C, S/m, dbar, and ml/L, and enable output of temperature, conductivity, pressure, and oxygen (disable salinity, sound velocity, specific conductivity, and sample number).

x=1: Reset output units to °C, µS/cm, psi, and mg/L (typical for coastal applications), and enable output of temperature, pressure, oxygen, and specific conductivity (disable conductivity, salinity, sound velocity, and sample number).

Note:

Specific conductivity
= $C / (1 + A * [T - 25])$

where

- C = conductivity (same units as specific conductivity: µS/cm, mS/cm, or S/m)
- T = temperature (°C)
- A = thermal coefficient of conductivity for natural salt ion solutions (default 0.020).

Note:

The parameters reset by **SetCoastal=** can be individually set using **SetTempUnits=**, **SetCondUnits=**, **SetPressUnits=**, **SetOxUnits=**, **OutputTemp=**, **OutputCond=**, **OutputPress=**, **OutputOx=**, **OutputSal=**, **OutputSV=**, **OutputSC=**, and **TxSampleNum=**.

Legacy=x**Note:**

Legacy=1 forces the 37-SMP-ODO to have output data strings like older 37-SMP-ODOs that did not have SDI-12 capability. Those instruments did not have as many user output selections. **Legacy=1** is intended for use only by customers who have a mix of old and new instruments, and **who are not using the SDI-12 capabilities of this 37-SMP-ODO**.

x=0: Allow all commands documented in this manual

x=1: Reset output units to °C, S/m, dbar, and ml/L, and enable output of temperature, conductivity, pressure, and oxygen (disable sound velocity, specific conductivity, and sample number). Do not allow user to disable temperature, conductivity, pressure, or oxygen, or to change output units. Modify **DS** response to match older instruments that did not have SDI-12 capability.

Autonomous Sampling (Logging) Commands

Logging commands direct the MicroCAT to sample data at pre-programmed intervals and store the data in its FLASH memory. Pump operation is dependent on the settings for **MinCondFreq=** and **AdaptivePumpControl=**, and on the temperature and pressure of the previous sample, as described in *Pump Operation* in *Section 2: Description of MicroCAT*.

Notes:

- Autonomous sampling is not compatible with SDI-12 operation.
- If the MicroCAT is logging data and the battery pack voltage is less than 7.1 volts for five consecutive scans, the MicroCAT halts logging.
- If the FLASH memory is filled to capacity, sampling continues but excess data is not saved in memory (i.e., the MicroCAT does not overwrite the data in memory).

SampleInterval=x

x= interval (sec) between samples (10 – 21,600). When commanded to start sampling with **StartNow** or **StartLater**, at **x** sec intervals MicroCAT takes measurement (running pump before each measurement), stores data in FLASH memory, transmits real-time data (if communicating via RS-232 and **TxRealTime=Y**), and goes to sleep. Note: Do not set **SampleInterval=** to less than (pumping time + sampling time + 5 sec); see *Pump Operation* in *Section 2: Description of MicroCAT* for details.

StartNow

Start logging now, at rate defined by **SampleInterval=**. Data is stored in FLASH memory. Data is transmitted real-time if connected via RS-232 and **TxRealTime=Y**.

Notes:

- After receiving **StartLater**, the MicroCAT displays `not logging: start at` in reply to **DS**. Once logging has started, the reply displays `logging`.
- If the delayed start date and time has already passed when **StartLater** is received, the MicroCAT executes **StartNow**.
- If the delayed start date and time is more than 30 days in the future when **StartLater** is received, the MicroCAT assumes that the user made an error in setting the delayed start date and time, and it executes **StartNow**.

StartDateTime=mmddyyyyhhmmss

Set delayed logging start month, day, year, hour, minute, second.

StartLater

Start logging at time set with delayed start date and time command, at rate defined by **SampleInterval**. Data is stored in FLASH memory. Data is transmitted real-time if **TxRealTime=Y**. If you need to change MicroCAT setup after **StartLater** has been sent (but before logging has started), send **Stop**, change setup as desired, and then send **StartLater** again.

Example: Program MicroCAT to start logging on 20 September 2012 12:00:00 (user input in bold).

```
STARTDATETIME=09202012120000
STARTLATER
```

Note:

You may need to send **Stop** several times to get the MicroCAT to respond. This is most likely to occur if sampling with a small **SampleInterval** and transmitting real-time data (**TxRealTime=Y**).

Stop

Stop logging (started with **StartNow** or **StartLater**) or stop waiting to start logging (if **StartLater** was sent but logging has not begun yet). Connect to MicroCAT (*Connect* in *Seaterm232*'s Communications menu) before entering **Stop**. **Stop** must be sent before uploading data from memory.

Polled Sampling Commands

These commands are used to request 1 or more samples from the MicroCAT. Unless noted otherwise, the MicroCAT does **not** store the data in FLASH memory.

Note:

See *Pump Operation* in *Section 2: Description of MicroCAT* for details.

For polled sampling commands that run the pump (**TPS**, **TPSH**, **TPSS**, **TPSN:x**, **SLTP**), pump operation is dependent on:

- Conductivity frequency from the last sample, and the setting for **MinCondFreq=**,
- Setting for **AdaptivePumpControl=**, and
- Temperature and pressure of the previous sample.

TS	Do not pump. Take sample, store data in buffer, output data.
TSR	Do not pump. Take sample, store data in buffer, output data in raw decimal format (regardless of OutputFormat=).
TPS	Run pump, take sample, store data in buffer, output data.
TPSH	Run pump, take sample, store data in buffer (do not output data).
TPSS	Run pump, take sample, store data in buffer and FLASH memory , output data. Note: MicroCAT ignores this command if sampling data (StartNow or StartLater has been sent).
TPSN:x	Do not pump. Take x samples and output data. To interrupt, press Esc key. Note: MicroCAT ignores this command if sampling data (StartNow or StartLater has been sent).
TPSN:x	Run pump continuously while taking x samples and outputting data. To interrupt this sampling, press Esc key. Note: MicroCAT ignores this command if sampling data (StartNow or StartLater has been sent).
T63	Do not pump. Command SBE 63 to take 1 sample, and output oxygen data in format set by SetFormat= in <i>SBE 63</i> .
SL	Output last sample stored in buffer.
SLTP	Output last sample stored in buffer. Then run pump, take new sample, and store data in buffer (do not output data from new sample).

Note:

The MicroCAT has a buffer that stores the most recent data sample. Unlike data in the FLASH memory, data in the buffer is erased upon removal or failure of power.

Data Upload Commands

Stop sampling (send **Stop**) before uploading data.

Notes:

- **Use Seaterm232's Upload menu to upload data that will be processed by SBE Data Processing.** Manually entering a data upload command does not produce data with the required header information for processing by our software. These commands are included here for reference for users who are writing their own software.
- **If not using the Upload menu -** To save data to a file, click Capture before entering a data upload command.
- See *Data Formats* after these *Command Descriptions*.

GetSamples:b,e

Upload data from scan **b** to scan **e**, in format defined by **OutputFormat=**. First sample is number 1. As data is uploaded, screen first displays
 start time =
 start sample number =
 These are start time and starting sample number for requested data.

DDb,e

Upload data from scan **b** to scan **e**, in converted decimal form (**OutputFormat=1**) (regardless of **OutputFormat=**). First sample is number 1. As data is uploaded, screen first displays
 start time =,
 start sample number =
 These are start time and starting sample number for requested data.

Example: Upload samples 1 to 200 to a file (user input in bold).

(Click Capture menu and enter desired filename in dialog box)

GETSAMPLES : 1 , 200

or

DD1 , 200

Calibration Coefficients Commands

Calibration coefficients are initially factory-set and should agree with Calibration Certificates shipped with the MicroCAT.

Note:

F = floating point number
S = string with no spaces

Temperature

TCalDate=S	S=Temperature calibration date.
TA0=F	F=Temperature A0.
TA1=F	F=Temperature A1.
TA2=F	F=Temperature A2.
TA3=F	F=Temperature A3.

Conductivity

CCalDate=S	S=Conductivity calibration date.
CG=F	F=Conductivity G.
CH=F	F=Conductivity H.
CI=F	F=Conductivity I.
CJ=F	F=Conductivity J.
WBOTC=F	F=Conductivity wbotc.
CTCor=F	F=Conductivity ctcor.
CPCor=F	F=Conductivity cpcor.

Pressure

PCalDate=S	S=Pressure calibration date.
PA0=F	F=Pressure A0.
PA1=F	F=Pressure A1.
PA2=F	F=Pressure A2.
PTCA0=F	F=Pressure ptca0.
PTCA1=F	F=Pressure ptca1.
PTCA2=F	F=Pressure ptca2.
PTCB0=F	F=Pressure ptcb0.
PTCB1=F	F=Pressure ptcb1.
PTCB2=F	F=Pressure ptcb2.
PTempA0=F	F=Pressure temperature a0.
PTempA1=F	F=Pressure temperature a1.
PTempA2=F	F=Pressure temperature a2.
POffset=F	F=Pressure offset (decibars).

Note:

Dissolved oxygen sensor coefficients are also stored separately in the SBE 63.

- **Coefficients stored in the SBE 63** are used to output converted oxygen data in response to **Send63=TS** or **T63**. To modify those coefficients, use the **Send63=** command to send calibration coefficient commands to the SBE 63; see the SBE 63 manual for those commands.
- **Coefficients stored in the MicroCAT** are used to output converted oxygen data in response to all other commands. They are also placed in the configuration (.xmlcon) file automatically created when you upload data from the MicroCAT memory. The .xmlcon file is used by SBE Data Processing when post-processing the uploaded data.

Dissolved Oxygen

OxCalDate=S	S= Oxygen calibration date.
OxTau20=F	F= Oxygen Tau20 (sensor response time).
OxA0=F	F= Oxygen A0 coefficient.
OxA1=F	F= Oxygen A1 coefficient.
OxA2=F	F= Oxygen A2 coefficient.
OxB0=F	F= Oxygen B0 coefficient.
OxB1=F	F= Oxygen B1 coefficient.
OxC0=F	F= Oxygen C0 coefficient.
OxC1=F	F= Oxygen C1 coefficient.
OxC2=F	F= Oxygen C2 coefficient.
OxTA0=F	F= Oxygen TA0 coefficient.
OxTA1=F	F= Oxygen TA1 coefficient.
OxTA2=F	F= Oxygen TA2 coefficient.
OxTA3=F	F= Oxygen TA3 coefficient.
OxE=F	F= Oxygen E coefficient.

Command Descriptions and Data Output Format – Transmission via SDI-12

All SDI-12 commands:

- Are case sensitive.
- Are terminated with ‘!’ (except as noted).
- Start with the SDI-12 address, designated as ‘a’ in the command descriptions below (0-9, a-z, A-Z).

All SDI-12 command responses:

- Are terminated with <CR><LF> (except as noted).

SDI-12 Standard Commands

Break

Command	Response	Description
Break	None; initiate search for valid mark.	12 millisecc spacing on line - Wake all MicroCATs on line. Note: ‘!’ command termination and <CR><LF> do not apply.

Acknowledge Active

Command	Response	Description
a!	a <CR><LF>	Check that MicroCAT ‘a’ is responding.

Send Identification

Command	Response	Description
a!	Allccccccmmmmmv.vnnnn ooooooo<CR><LF> <i>where</i> ll = SDI-12 version compatibility (13 = 1.3) cccccc = vendor ID (‘Sea-Bird’) mmmmm = Instrument ID (‘37SMP-’) v.v = MicroCAT firmware version (‘2.4’) nnnn = MicroCAT serial number ooooooo= up to 8 characters, designation of optional sensors (P if pressure installed, O if oxygen installed) <i>Example string when 37-SMP-ODO’s SDI-12 address is 0, serial number is 03712345, and pressure sensor is installed:</i> 013Sea-Bird37SMP-2.412345PO	Identify instrument. Notes: <ul style="list-style-type: none"> • Serial number is last 5 characters of serial number (037xxxx). • Firmware version in a! response is limited to number of digits shown. Use aXV! (see SDI-12 Extended Commands) to get full firmware version. For example, for firmware version 2.4.2, a! will return ‘2.4’, while aXV! will return ‘2.4.2’.

SDI-12 Address Query

Command	Response	Description
?!	a<CR><LF>	Get MicroCAT’s SDI-12 address; valid only if just 1 MicroCAT online.

Change SDI-12 Address

Command	Response	Description
aAb!	b<CR><LF>	Change MicroCAT’s SDI-12 address from ‘a’ to ‘b’.

Note:

Responses to Start Measurement commands include:

- a = SDI-12 address
- ttt = maximum amount of time (sec) until data is ready
- n (1 digit, for M commands) or nn (2 digits, for C [Concurrent] commands) = number of parameters in data string (can include T, C, P, DO, salinity, sound velocity, specific conductivity, sample number; dependent on which outputs are enabled)

Start Measurement TPSS (run pump; store data in MicroCAT FLASH memory)

Command	Response	Description
aM!	atttn<CR><LF> <i>(followed by)</i> a<CR><LF> <i>(when data is ready)</i>	Send TPSS to MicroCAT (run pump, take sample, store data in buffer, and store data in MicroCAT's FLASH memory for later upload). Hold results in MicroCAT buffer until another sample taken. Service request issued when data ready.
aMC!	Same as aM!	Same as aM!, but response in buffer includes 3-character checksum before <CR><LF>.
aC!	atttn<CR><LF>	Same as aM!, but service request (a<CF><LF>) not sent.
aCC!	Same as aC!	Same as aC!, but response in buffer includes 3 character checksum before <CR><LF>.

Start Measurement TPS (run pump; do **not** store data in FLASH memory)

Command	Response	Description
aM1!	atttn<CR><LF> <i>(followed by)</i> a<CR><LF> <i>(when data is ready)</i>	Send TPS to MicroCAT (run pump, take sample, store data in buffer). Hold results in MicroCAT buffer until another sample taken. Service request issued when data ready.
aMC1!	Same as aM1!	Same as aM1!, but response in buffer includes 3-character checksum before <CR><LF>.
aC1!	atttn<CR><LF>	Same as aM1!, but service request (a<CF><LF>) not sent.
aCC1!	Same as aC1!	Same as aC1!, but response in buffer includes 3 character checksum before <CR><LF>.

Start Measurement TS (do **not** run pump or store data in FLASH memory)

Command	Response	Description
aM2!	atttn<CR><LF> <i>(followed by)</i> a<CR><LF> <i>(when data is ready)</i>	Send TS to MicroCAT (do not run pump ; take sample, store data in buffer). Hold results in MicroCAT buffer until another sample taken. Service request issued when data ready.
aMC2!	Same as aM2!	Same as aM2!, but response in buffer includes 3-character checksum before <CR><LF>.
aC2!	atttn<CR><LF>	Same as aM2!, but service request (a<CF><LF>) not sent.
aCC2!	Same as aC2!	Same as aC2!, but response in buffer includes 3 character checksum before <CR><LF>.

Send Data

Command	Response	Description
aD0!	a<values><CRC><CR><LF> <i>where</i> <values> = parameters in data string (can include T, C, P, DO, salinity, sound velocity, specific conductivity, sample number; dependent on which outputs are enabled) CRC is sent if Start Measurement command included CRC request (aMC!, aMC1!, aCC!, aCC1!, etc.)	Send data from MicroCAT buffer. If string is too long, additional commands (aD1!, aD2!, etc.) required to retrieve remaining data. Number of characters in values plus CRC string is limited to 75 for Concurrent data (sampling command string includes 'C'), or 35 for non-Concurrent data (sampling command string includes 'M').

SDI-12 Extended Commands

The following commands, defined by an 'X', make it possible to perform common setup changes in the field without connecting to a computer:

Command	Response	Description
aXV!	av.v.v, mmm dd yyyy hh:mm:ss <CR><LF> <i>where</i> v.v.v = firmware version mm dd yyyy = firmware date hh:mm:ss = firmware time	Get full MicroCAT firmware version string (firmware version and firmware date).
aXPx!	ax<CR><LF>	Send PumpOn (1) or PumpOff (0) . Turn pump on to test or remove sediment; runs continuously, drawing current.
aXMCFx!	ax<CR><LF>	Send MinCondFreq=x . Minimum conductivity frequency (Hz) to enable pump turn-on, to prevent pump from running in air. Configuration Sheet lists frequency output at 0 conductivity. Typical MinCondFreq values: salt water & estuarine: (0 conductivity frequency + 500). fresh water: (0 conductivity frequency + 5).
aXMRx!	xx<CR><LF> <i>where</i> xx = current sample number Note: must send aXMR0! twice. Response to first command shows current sample number. Response to second command shows that sample number has been reset to 0 (memory has been reset).	Send InitLogging when x=0 . After all data has been uploaded , initialize logging to make entire memory available for recording. If not initialized, data is stored after last recorded sample. MicroCAT requires command to be sent twice, to prevent accidental reset of memory.
aXUTx!	ax<CR><LF>	Send SetTempUnits=x . x=0 : Temperature °C, ITS-90. x=1 : °F, ITS-90.
aXUCx!	ax<CR><LF>	Send SetCondUnits=x . x=0 : Conductivity S/m. x=1 : mS/cm. x=2 : µS/cm.
aXUPx!	ax<CR><LF>	Send SetPressUnits=x . x=0 : Pressure decibars. x=1 : psi (gauge).
aXUOx!	ax<CR><LF>	Send SetOxUnits=x . x=0 : Oxygen ml/L. x=1 : mg/L.
aXOxxxxxxxx!	axxxxxxxxx<CR><LF> <i>where</i> xxxxxxxx=enable (1)/disable (0) status for each output parameter (in order: temperature, conductivity, pressure, oxygen, salinity, sound velocity, specific conductivity, sample number) <i>Example (enable T, C, P, O, salinity):</i> a11111000 <i>Example (enable T, C, O, salinity; no pressure installed):</i> a11x11000	Send OutputTemp=x , OutputCond=x , OutputPress=x , OutputOx=x , OutputSal=x , OutputSV=x , OutputSC=x , TxSampleNum=x . x=0 : Disable output. x=1 : Enable output.
aXUR!	a<CR><LF>	Send SetCoastal=1 . Reset units to °C, µS/cm, psi, mg/L; enable temperature, pressure, oxygen, and specific conductivity (disable other outputs).

Note:

For all extended commands with an argument (x): If the argument is omitted, the response provides the current setting.

Note:

If the MicroCAT does not have a pressure sensor:

- The pressure enable/disable character has no effect on the output, but must be included in the string.
- MicroCAT returns an 'x' for the current pressure output setting.

SDI-12 Data Format

The **identification string** (a!) for SDI-12 is:

```
a!3Sea-Bird<Model Number><Firmware version><Serial Number><Optional Sensors>
```

where

- a = SDI=12 address
 - Firmware version = 3 characters (v.v); use aXV! to get the full firmware version (for example, for firmware 2.4.2, a! shows the firmware as 2.4, while aXV! shows the firmware as 2.4.2)
 - Model number = 6 characters (**37SMP-** for this MicroCAT)
 - Serial number = last 5 characters of MicroCAT serial number (037xxxxx)
 - Optional Sensors = up to 8 characters
 - P = pressure sensor installed
 - O = dissolved oxygen sensor installed (**always for this MicroCAT**)
- additional characters available for future products*

Example: Identification string for MicroCAT with SDI-12 address 0, when MicroCAT's serial number is 03712345 and **pressure sensor is installed**:
013Sea-Bird37SMP-2.412345PO

Note:

MicroCAT automatically outputs in this format over the SDI-12 line. You do not need to set **OutputFormat=3**.

The **converted decimal data format** for SDI-12 is:

```
a+ttt.tttt+c+ppp.pppp+oo.ooo+sss.ssss+vvvv.vvv+x+n
```

where

- a = SDI=12 address
- (+ or -) sign precedes each parameter
- ttt.tttt = temperature (sent if **OutputTemp=Y**; units defined by **SetTempUnits=**).
- c = conductivity (sent if **OutputCond=Y**; units defined by **SetCondUnits=**).
 - cc.ccccc if **SetCondUnits=0** (S/m)
 - ccc.cccc if **SetCondUnits=1** (mS/cm)
 - cccc.c if **SetCondUnits=2** (μS/cm)
- pppp.ppp = pressure (sent if optional pressure sensor installed and **OutputPress=Y**; units defined by **SetPressUnits=**).
- oo.ooo = oxygen (sent if **OutputOx=Y**; units defined by **SetOxUnits=**).
- sss.ssss = salinity (psu); sent if **OutputSal=Y**.
- vvvv.vvv = sound velocity (m/sec); sent if **OutputSV=Y**.
- x = specific conductivity; sent if **OutputSC=Y** (units defined by **SetCondUnits=**).
 - xx.xxxxx if **SetCondUnits=0** (S/m)
 - xxx.xxxx if **SetCondUnits=1** (mS/cm)
 - xxxxx.x if **SetCondUnits=2** (μS/cm)
- n = sample number in FLASH memory (sent if **TxSampleNum=y**, and using polled sampling command that stores data in FLASH memory).

Note the following:

- Polarity sign is always sent.
- Decimal point is optional.
- Maximum digits for a value is 7, even without a decimal point.
- Minimum digits for a value is 1.
- Maximum characters in data value is 9 (sign, 7 digits, decimal point).
- Leading zeros are suppressed, except for one zero to left of decimal point.

Example: Sample data output when pressure sensor is installed, aXUT0!, aXUC0!, aXUP0!, aXUO0!, and aXO1111111!
(outputting all parameters):

```
0+23.6261+0.00002-0.267+0.838+0.0115+1492.967+0.00002+1
```

(SDI-12 address, temperature, conductivity, pressure, oxygen, salinity, sound velocity, specific conductivity, sample number)

RS-232 Data Formats

Notes:

- Time is the time at the **start** of the sample.
- When **TxRealTime=Y**, real-time autonomous data transmitted via **RS-232** is preceded by a **#** sign.
- The MicroCAT's pressure sensor is an absolute sensor, so its **raw** output (**OutputFormat=0**) includes the effect of atmospheric pressure (14.7 psi). As shown on the Calibration Sheet, Sea-Bird's calibration (and resulting calibration coefficients) is in terms of psia. However, when outputting pressure in **psi** or **decibars**, the MicroCAT outputs pressure relative to the ocean surface (i.e., at the surface the output pressure is 0 psi or 0 dbar). The MicroCAT uses the following equations to convert psia:

$$P \text{ (psi)} = P \text{ (psia)} - 14.7$$

$$P \text{ (dbar)} = [P \text{ (psia)} - 14.7] * 0.689476$$

Defined below are the MicroCAT's RS-232 output data formats. Each scan ends with a carriage return <CR> and line feed <LF>.

- **OutputFormat=0**: raw decimal data, for diagnostic use at Sea-Bird
 tttttt, ccccc.ccc, pppppp, vvvv, oo.ooo, t.ttttt, dd mmm yyyy, hh:mm:ss

where

- tttttt = temperature A/D counts.
- ccccc.ccc = conductivity frequency (Hz).
- pppppp = pressure sensor pressure A/D counts; sent if pressure sensor installed.
- vvvv = pressure sensor pressure temperature compensation A/D counts; sent if pressure sensor installed.
- oo.ooo = oxygen sensor phase (μ sec).
- t.ttttt = oxygen sensor temperature voltage.
- dd mmm yyyy = day, month, year.
- hh:mm:ss = hour, minute, second.

Note that salinity, sound velocity, specific conductivity, and sample number are not sent, regardless of the setting for those parameters. All data is separated with a comma and a space.

Example: Sample data output when pressure sensor is installed and **OutputFormat=0**:

223474, 2723.945, 578618, 1965, 16.693, 0.686060, 14 Nov 2012, 08:32:05
 (temperature, conductivity, pressure sensor pressure, pressure sensor temperature compensation, oxygen phase, oxygen temperature voltage, date, time)

- **OutputFormat=1**: converted decimal data
tt.tttt, c, p.ppp, oo.ooo, sss.ssss, vvvv.vvv, x, dd mmm yyyy, hh:mm:ss, n

where

- tt.tttt = temperature (sent if **OutputTemp=Y**; units defined by **SetTempUnits=**).
- c = conductivity (sent if **OutputCond=Y**; units defined by **SetCondUnits=**).
c.ccccc if **SetCondUnits=0** (S/m)
cc.cccc if **SetCondUnits=1** (mS/cm)
cccc.c if **SetCondUnits=2** (μ S/cm)
- p.ppp = pressure (sent if pressure sensor installed and **OutputPress=Y**; units defined by **SetPressUnits=**.)
Number of digits to left of decimal place is dependent on pressure sensor range.
- oo.ooo = oxygen (sent if **OutputOx=Y**; units defined by **SetOxUnits=**).
- sss.ssss= salinity (psu); sent if **OutputSal=Y**.
- vvvv.vvv – sound velocity (m/sec); sent if **OutputSV=Y**.
- x = specific conductivity; sent if **OutputSC=Y**
(units defined by **SetCondUnits=**).
- x.xxxxx if **SetCondUnits=0** (S/m)
- xx.xxxx if **SetCondUnits=1** (mS/cm)
- xxxxx.x if **SetCondUnits=2** (μ S/cm)
- dd mmm yyyy = day, month, year.
- hh:mm:ss = hour, minute, second.
- n = sample number in FLASH memory (sent if **TxSampleNum=y**, and autonomous sampling or using polled sampling commands that store data in FLASH memory or retrieve last sample from FLASH memory).

Leading zeros are suppressed, except for one zero to the left of the decimal point. All data is separated with a comma and at least one space.

Example: Sample data output for real-time autonomous data transmitted via RS-232 when pressure sensor is installed, **OutputFormat=1**, **SetTempUnits=0**, **SetCondUnits=0**, **SetPressUnits=0**, **SetOxUnits=0**, and outputting all parameters:
23.6261, 0.00002, -0.267, 0.838, 0.0115, 1492.967, 0.00002, 20 Nov 2012, 12:28:00, 1
(temperature, conductivity, pressure, oxygen, salinity, sound velocity, specific conductivity, date, time, sample number)

Note:

For ease in reading, the data structure is shown with each XML tag on a separate line. However, there are no carriage returns or line feeds between tags (see example below).

- **OutputFormat=2:** converted decimal data in XML

```
<?xml version="1.0"?>
<datapacket>
<hdr>
<mfg>Sea-Bird</mfg>
<model>37SMP-ODO-SDI12</model>
<sn>037nnnn</sn>
</hdr>
<data>
<t1>ttt.ttt</t1>
<c1>c</c1>
<p1>p.ppp </p1>
<ox63r>oo.ooo </ox63r>
<sal>sss.ssss</sal>
<sv>vvvv.vvv </sv>
<sc>x</sc>
<smpl>n</smpl>
<dt>yyyy-mm-ddThh:mm:ss</dt>
</data>
</datapacket>
```

where

- 037nnnn = MicroCAT serial number
- ttt.ttt = temperature (sent if **OutputTemp=Y**; units defined by **SetTempUnits=**).
- c = conductivity (sent if **OutputCond=Y**; units defined by **SetCondUnits=**).
 - c.ccccc if **SetCondUnits=0** (S/m)
 - cc.cccc if **SetCondUnits=1** (mS/cm)
 - cccc.c if **SetCondUnits=2** (μS/cm)
- p.ppp = pressure (sent if pressure sensor installed and **OutputPress=Y**; units defined by **SetPressUnits=**). Number of digits to left of decimal place is dependent on pressure sensor range.
- oo.ooo = oxygen (sent if **OutputOx=Y**; units defined by **SetOxUnits=**).
- sss.ssss = salinity (psu); sent if **OutputSal=Y**.
- vvvv.vvv – sound velocity (m/sec); sent if **OutputSV=Y**.
- x = specific conductivity; sent if **OutputSC=Y** (units defined by **SetCondUnits=**).
 - x.xxxxx if **SetCondUnits=0** (S/m)
 - xx.xxxx if **SetCondUnits=1** (mS/cm)
 - xxxxx.x if **SetCondUnits=2** (μS/cm)
- dd mmm yyyy = day, month, year.
- hh:mm:ss = hour, minute, second.
- n = sample number in FLASH memory (sent if **TxSampleNum=y**, and autonomous sampling or using polled sampling commands that store data in FLASH memory or retrieve last sample from FLASH memory).

Leading zeros are suppressed, except for one zero to the left of the decimal point.

Example: Sample data output for real-time autonomous data transmitted via RS-232 when pressure sensor is installed, **OutputFormat=2**, **SetTempUnits=0**, **SetCondUnits=0**, **SetPressUnits=0**, **SetOxUnits=0**, and outputting all parameters:

```
<?xml version="1.0"?><datapacket><hdr><mfg>Sea-Bird</mfg><model>37SMP-ODO-SDI12</model>
<sn>03700000</sn></hdr><data><t1>23.6261</t1><c1>0.00002</c1><p1>-0.267</p1>
<ox63r>0.838</ox63r><sal>0.0115</sal><sv>1492.967</sv><sc>0.00002</sc><smpl>1</smpl>
<dt>2012-11-20T12:28:00</dt></data></datapacket> CRLF
(temperature, conductivity, pressure, oxygen, salinity, sound velocity, specific conductivity, sample number, date and time)
```

Note:

MicroCAT automatically outputs in this format over the SDI-12 line. Setting **OutputFormat=3** allows you to view the SDI-12 data output string while communicating via RS-232.

- **OutputFormat=3**: converted decimal data in SDI-12 format

a+ttt.tttt+c+ppp.pppp+oo.ooo+sss.ssss+vvvv.vvv+x+n

where

- a = SDI-12 address
- (+ or -) sign precedes each parameter
- ttt.tttt = temperature (sent if **OutputTemp=Y**; units defined by **SetTempUnits=**).
- c = conductivity (sent if **OutputCond=Y**; units defined by **SetCondUnits=**).
cc.cccc if **SetCondUnits=0** (S/m)
ccc.cccc if **SetCondUnits=1** (mS/cm)
cccc.c if **SetCondUnits=2** (μS/cm)
- pppp.ppp = pressure (sent if pressure sensor installed and **OutputPress=Y**; units defined by **SetPressUnits=**).
- oo.ooo = oxygen (sent if **OutputOx=Y**; units defined by **SetOxUnits=**).
- sss.ssss = salinity (psu); sent if **OutputSal=Y**.
- vvvv.vvv = sound velocity (m/sec); sent if **OutputSV=Y**.
- x = specific conductivity; sent if **OutputSC=Y** (units defined by **SetCondUnits=**).
xx.xxxxx if **SetCondUnits=0** (S/m)
xxx.xxxx if **SetCondUnits=1** (mS/cm)
xxxxx.x if **SetCondUnits=2** (μS/cm)
- n = sample number in FLASH memory (sent if **TxSampleNum=y**, and autonomous sampling or using polled sampling commands that store data in FLASH memory or retrieve last sample from FLASH memory).

Note the following:

- Polarity sign is always sent.
- Decimal point is optional.
- Maximum digits for a value is 7, even without a decimal point.
- Minimum digits for a value is 1.
- Maximum characters in data value is 9 (sign, 7 digits, decimal point).
- Leading zeros are suppressed, except for one zero to left of decimal point.

Example: Sample data output when pressure sensor is installed, **OutputFormat=3**, **SetTempUnits=0**, **SetCondUnits=0**, **SetPressUnits=0**, **SetOxUnits=0**, and outputting all parameters:

0+23.6261+0.00002-0.267+0.838+0.0115+1492.967+0.00002+1

(SDI-12 address, temperature, conductivity, pressure, oxygen, salinity, sound velocity, specific conductivity, sample number)

Optimizing Data Quality / Deployment Orientation

Note:

A pump clogged with sediment results in poor flushing, causing poor quality data.

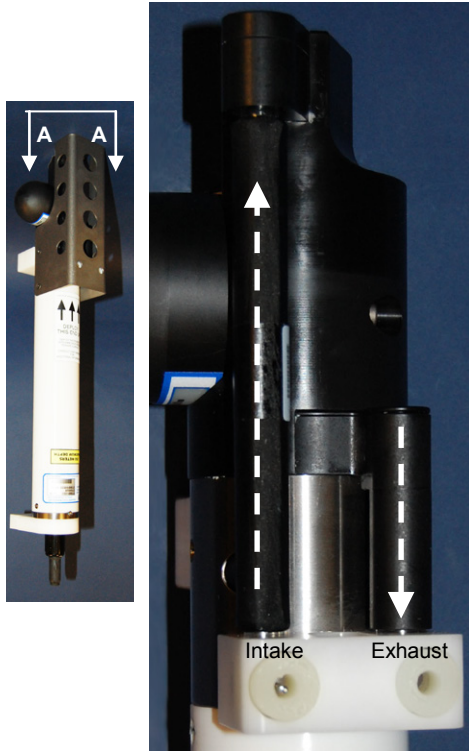

Shown with conductivity cell guard removed

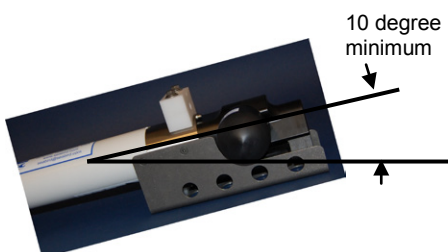
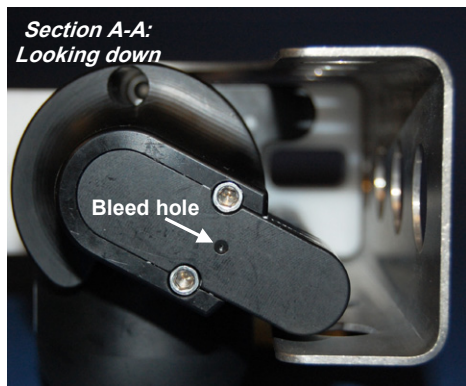

Background Information

Sea-Bird's general recommendation is to deploy the MicroCAT with the plumbing in an **inverted** U-shape, to minimize the ingestion of sediment. A small bleed hole in the duct provides a way for air to exit the plumbing, so that the pump will prime and operate. In considering the effect of air on the pump, it can be instructive to look at the amount of air in the water column:

- **Case 1:** The top ~2 meters of the water column may contain a continuous supply of bubbles injected into the system by breaking waves. In this area, the ability to continuously eliminate air from the system, throughout the deployment, is of prime concern.
- **Case 2:** The next ~30 meters of the water column is not typically affected by bubbles from breaking waves. *Without a bleed hole*, it could take a few days to weeks after deployment for the air to clear out of the system in an inverted U-shape. However, once the air was bled, no more air would be injected into the plumbing.
- **Case 3:** Below ~30 meters, *without a bleed hole*, it could take only a few hours to a day for the air to clear out of the system in an inverted U-shape. As in Case 2, once the air was bled, no more air would be injected into the plumbing.

The bleed hole, while providing a way for air to exit the plumbing, also provides a little more ventilation; this ventilation will cause a slight decrease in the concentration of anti-foulant in the water held in the plumbing between samples. In our judgment, and the experience of customers, the risk of poor data due to sediment accumulation is usually greater than the risk of slightly reduced effectiveness of the anti-foulant, or is at least a reasonable trade-off.

Deployment Recommendations

- **Most deployments** – Deploy the MicroCAT with the plumbing in an **inverted** U-shape (as shown in the photos), allowing air to exit the plumbing through the bleed hole.
- **Deployments where severe bio-fouling is the main concern and sediment is not an issue** –
 - Case A:* You need accurate data immediately upon deployment - **Plug the bleed hole.** Deploy the MicroCAT with the plumbing in an **upright** U-shape, providing maximum bio-foul protection but leaving the MicroCAT vulnerable to ingestion of sediment.
 - Case B:* You can skip some initial data, allowing time for trapped air to dissolve into the water and the pump to prime properly – **Plug the bleed hole.** Deploy the MicroCAT with the plumbing in an **inverted** U-shape, providing maximum bio-foul protection as well as protection from the ingestion of sediment. This deployment method will provide good data within a day if the deployment is deeper than ~30 meters. Eliminate scans associated with the initial deployment by evaluating the conductivity data; minimal changes in conductivity are an indication that pump flow is not correct because air in the plumbing has prevented the pump from priming.
- **Deployments where air bubbles are the main concern and sediment is not an issue - Plug the bleed hole.** Deploy the MicroCAT with the plumbing in an **upright** U-shape. This orientation provides better bleeding of air from the plumbing than can be achieved with the small bleed hole, but leaves the MicroCAT vulnerable to ingestion of sediment.
- **Deployments where (for mounting reasons) the preferred orientation is horizontal** – Sea-Bird does not recommend horizontal mounting, because sediment can accumulate in the conductivity cell, resulting in very poor quality conductivity data. **As a minimum, incline the MicroCAT 10 degrees above the horizontal, with the inlet and exhaust pointing down**, to prevent sediment accumulation and provide proper pump operation.

Setup for Deployment

1. Install new AA lithium cells(see *Section 5: Routine Maintenance and Calibration*) or ensure the existing battery pack has enough capacity to cover the intended deployment.
2. Ensure all data has been uploaded, and then send **InitLogging** to make the entire memory available for recording. If **InitLogging** is not sent, data will be stored after the last recorded sample.
3. Set the date and time (**DateTime=**).
4. **For SDI-12 Deployment:** Program the MicroCAT for the intended deployment (see information in this section on commands and sampling modes):
 - A. Set the address (**SetAddress=** via RS-232, or aAb! via SDI-12) for SDI-12 communications
 - B. Set other parameters as desired.
 - C. Program the SDI-12 controller to send periodic requests to run the pump and take a sample (aM!, aMC!, aC!, or aCC! store data in MicroCAT FLASH memory; aM1!, aMC1!, aC1!, or aCC1! do not store data in FLASH memory), and then to transmit the sample (aD0!, aD1!, etc.).
5. **For RS-232 Deployment:** Program the MicroCAT for the intended deployment (see information in this section on commands and sampling modes):
 - A. Set up the MicroCAT as desired.
 - B. If you want the MicroCAT to sample autonomously when deployed, use **one** of the following command sequences to initiate logging.:
 - **StartNow** to start logging now, taking a sample every **SampleInterval=** seconds.
 - **StartDateTime=** and **StartLater** to start logging at the specified date and time, taking a sample every **SampleInterval=** seconds.

Note:

You can program the RS-232 controller to send periodic requests to transmit the last data sample from the MicroCAT memory (**SL**), while sampling autonomously. Alternatively, if not interested in sampling autonomously, you can program the controller to send periodic requests to take and transmit a sample (**TPS** or **TPSS**).

Deployment



CAUTIONS:

- Do not use **WD-40** or other petroleum-based lubricants, as they will damage the connectors.
- For wet-pluggable MCBH connectors: **Silicone lubricants in a spray can** may contain ketones, esters, ethers, alcohols, or glycols in their propellant. **Do not use these sprays, as they will damage the connector.**

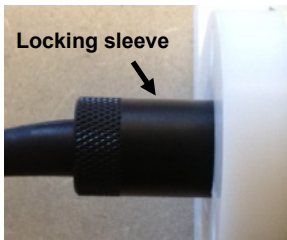
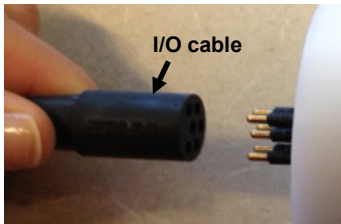

For most applications, deploy in orientation shown (connector at bottom)

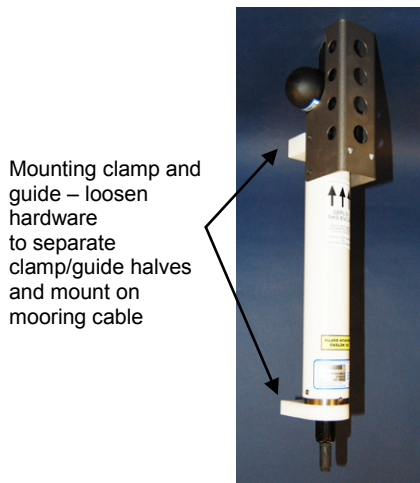

The MicroCAT comes with a pre-installed Sea-Bird wire mounting clamp and guide.

1. New MicroCATs are shipped with AF24173 Anti-Foulant Devices and a yellow protective label pre-installed.
 - A. Remove the protective label, if installed, from the intake and exhaust. **The label must be removed prior to deployment or pressurization.** If the label is left in place, the flow will be impeded, the sensor will not operate properly, and you may cause severe damage to the conductivity cell.
 - B. Verify that the Anti-Foulant Devices are installed (see *Replacing Anti-Foulant Devices – Mechanical Design Change in Section 5: Routine Maintenance and Calibration*).

2. Install the dummy plug or I/O cable (for external power and/or communication during deployment):
 - A. Lightly lubricate the inside of the dummy plug or cable connector with silicone grease (DC-4 or equivalent).
 - B. Install the plug/cable connector, aligning the pins.
 - C. Place the locking sleeve over the plug/connector. Tighten the locking sleeve finger tight only. **Do not overtighten the locking sleeve and do not use a wrench or pliers.**

3. Attach the mounting clamp and guide to the mooring cable. See *Optimizing Data Quality / Deployment Orientation* for deployment recommendations.

4. Verify that the hardware and external fittings are secure.
5. Deploy the MicroCAT.

Recovery

WARNING!

If the MicroCAT stops working while underwater, is unresponsive to commands, or shows other signs of flooding or damage, carefully secure it away from people until you have determined that abnormal internal pressure does not exist or has been relieved. Pressure housings may flood under pressure due to dirty or damaged o-rings, or other failed seals. When a sealed pressure housing floods at great depths and is subsequently raised to the surface, water may be trapped at the pressure at which it entered the housing, presenting a danger if the housing is opened before relieving the internal pressure. Instances of such flooding are rare. However, a housing that floods at 350 meters depth holds an internal pressure of more than 500 psia, and has the potential to eject the end cap with lethal force.

A housing that floods at 50 meters holds an internal pressure of more than 85 psia; this force could still cause injury.

If you suspect the MicroCAT is flooded, point it in a safe direction away from people, and loosen the bulkhead connector very slowly, at least 1 turn. This opens an o-ring seal under the connector. Look for signs of internal pressure (hissing or water leak). If internal pressure is detected, let it bleed off slowly past the connector o-ring. Then, you can safely remove the end cap.

1. Rinse the instrument, conductivity cell, and dissolved oxygen sensor with fresh water. (See *Section 5: Routine Maintenance and Calibration* for conductivity cell and oxygen sensor cleaning and storage.)
2. Install a yellow protective label over the intake and exhaust (1 extra label is included in the spares kit that ships with the MicroCAT).



3. If the battery pack is exhausted, new cells must be installed before the data can be extracted. Stored data will not be lost as a result of exhaustion or removal of the battery pack. See *Section 5: Routine Maintenance and Calibration* for replacement of cells.
4. If immediate redeployment is not required, you can leave the MicroCAT with battery pack in place and in a quiescent state (**QS**). Because the quiescent current required is small, the battery pack can be left in place without significant loss of capacity.

Uploading and Processing Data

Note:

Data may be uploaded during deployment or after recovery. If uploading after recovery, connect the I/O cable as described in *Power and Communications Test* in *Section 3: Preparing MicroCAT for Deployment*.

1. Double click on **SeatermV2.exe**. The main screen appears.
2. In the Instruments menu, select *SBE 37 RS232*. **Seaterm232** opens.
3. Seaterm232 tries to automatically connect to the MicroCAT. As it connects, it sends **GetHD** and displays the response. Seaterm232 also fills the Send Commands window with the correct list of commands for your MicroCAT. **If there is no communication:**
 - A. In the Communications menu, select *Configure*. The Serial Port Configuration dialog box appears. Select the Comm port and baud rate for communication, and click OK. Note that the factory-set baud rate is documented on the Configuration Sheet.
 - B. In the Communications menu, select *Connect* (if *Connect* is grayed out, select *Disconnect and reconnect*). Seaterm232 will attempt to connect at the baud specified in Step A, but if unsuccessful will then cycle through all other available baud rates.
 - C. If there is still no communication, check cabling between the computer and MicroCAT.
 - D. If there is still no communication, repeat Step A with a different comm port, and try to connect again.
4. If sampling autonomously, command the MicroCAT to stop logging by pressing any key, typing **Stop**, and pressing the Enter key.
5. Display MicroCAT status information by typing **DS** and pressing the Enter key. The display looks like this:

```
SBE37SMP-ODO-SDI12 v2.4.2 SERIAL NO. 10103 11 Oct 2013 20:48:03
vMain = 13.08, vLith = 3.17
samplenum = 95, free = 399362
not logging, stop command
sample interval = 300 seconds
data format = converted engineering
output temperature, Celsius
output conductivity, uS/cm
output pressure, PSI
output oxygen, mg/L
output salinity, PSU
output sound velocity, m/s
output specific conductivity, uS/cm
user defined specific conductivity coefficient = 0.0200
output sample number
transmit real time data= yes
minimum conductivity frequency = 3224.1
adaptive pump control enabled
nTau = 7.0
SDI-12 address = 0
SDI-12 flag = +9999999
```

Note:

BaudRate= must be sent twice. After the first entry, the MicroCAT changes to the new baud, and then waits for the command to be sent again at the new baud (In Seaterm232's Communications menu, select *Configure*. In the dialog box, select the new baud rate and click OK. Then retype the command.). If it does not receive the command again at the new baud, it reverts to the previous baud rate.

- Verify that the status is **not logging**.
6. If desired, increase the MicroCAT's baud rate for data upload.

7. Click the Upload menu to upload stored data. Seaterm232 responds as follows:
 - A. Seaterm232 sends **GetHD** and displays the response, verifying that it is communicating with the 37-SMP-ODO.
 - B. Seaterm232 sends **OutputExecutedTag=Y**; this setting is required for the upload.
 - C. Seaterm232 sends **GetSD** and displays the response, providing information on the number of samples in memory.
 - D. In the Save As dialog box, enter the desired upload file name and click Save. The upload file has a .XML extension.
 - E. An Upload Data dialog box appears:

Note:
 If binary upload is selected, Seaterm232 uploads the data in binary and then converts it to ASCII text, resulting in a data file that is identical to one uploaded in ASCII text.

Select number of bytes uploaded in each block. Seaterm232 uploads data in blocks, and calculates a checksum at end of each block. If block fails checksum verification, Seaterm232 tries to upload block of data again, cutting block size in half.

Defines data upload type and range:

- All data as a single file – All data is uploaded into 1 file.
- By scan number range – Enter beginning scan (sample) number and total number of scans. All data within range is uploaded into 1 file.

To change upload file name selected in Step D above, click Browse to navigate to desired upload file path and name. Upload file has a .xml extension. After Seaterm232 uploads data into .xml data file, it creates .hex data file and .xmlcon configuration file that are compatible with SBE Data Processing. These files are placed in same directory as .xml data file, and have same name (but different extensions).

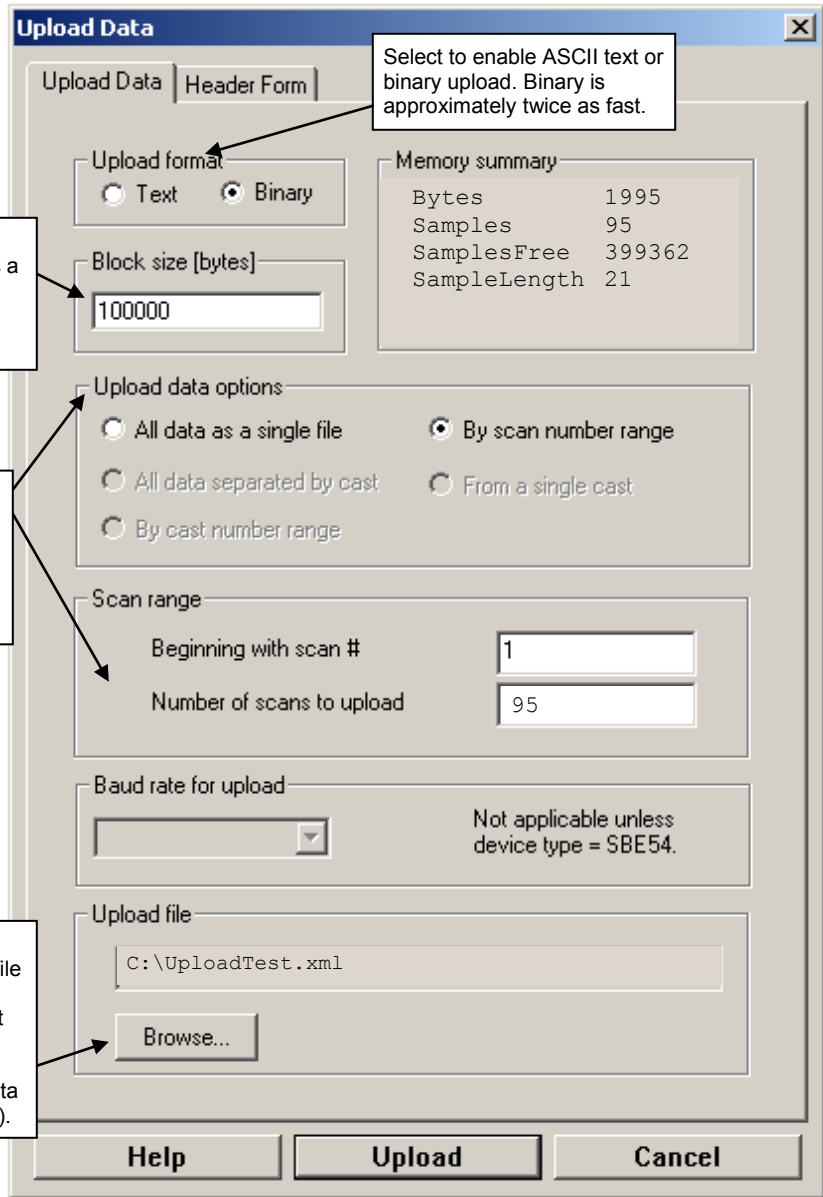

Make the desired selections.

8. Click the Header Form tab to customize the header:

Defines header information included with uploaded data:

- Prompt for header information – As data is uploaded, user is prompted to fill out user-defined header form.
- Include default header form in upload file – User-defined default header form included in upload file. User is not prompted to add any information when data is uploaded.
- Don't include default header form in upload file – Header information not included in upload file.

The entries are free form, 0 to 12 lines long. This dialog box establishes:

- the header prompts that appear for the user to fill in when uploading data, if *Prompt for header information* was selected
- the header included with the uploaded data, if *Include default header form in upload file* was selected

Enter the desired header/header prompts.

9. Click Upload; the Status bar at the bottom of the window displays the upload progress:
- A. Seaterm232 sends several status commands providing information regarding the number of samples in memory, calibration coefficients, etc., and writes the responses to the upload .xml file.
 - B. **If you selected *Prompt for header information* in the Upload Data dialog box** – a dialog box with the header form appears. Enter the desired header information, and click OK. Seaterm232 writes the header information to the upload .xml file.
 - C. Seaterm232 sends the data upload command, based on your selection of upload range in the Upload Data dialog box, and writes the data to the upload .xml file.
 - D. From the information in the .xml file, Seaterm232 creates a .hex data file and .xmlcon configuration file that are compatible with SBE Data Processing for processing and plotting the data. These files are placed in the same directory as the .xml data file and have the same name (but different extensions).

Notes:

- Ensure all data has been uploaded from the MicroCAT by reviewing the data in SBE Data Processing.
- If you do not run Data Conversion now, you can run it later by opening SBE Data Processing.
- See the SBE Data Processing manual and/or Help for details.

10. After the data has been uploaded, Seaterm232 prompts you to run SBE Data Processing's Data Conversion module if desired. Data Conversion converts the .hex (raw data) file to a .cnv file, which can then be processed by other modules in SBE Data Processing.

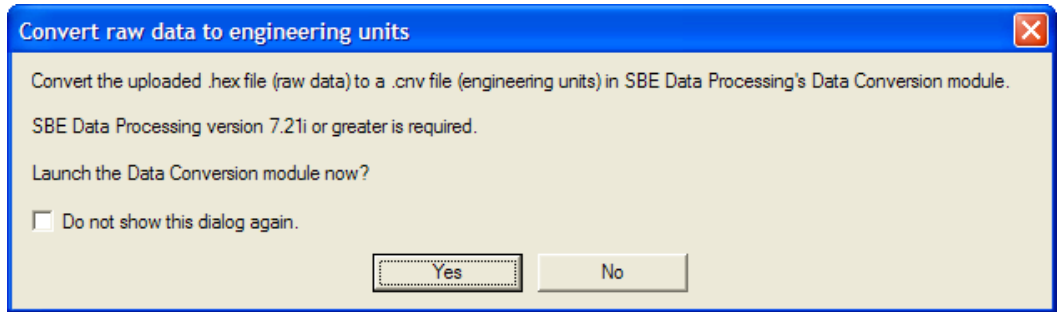

- A. If you click Yes, Seaterm232 opens SBE Data Processing's Data Conversion module, and fills in the appropriate instrument configuration (.xmlcon) file and data (.hex) file on the File Setup tab.

Location to store all setup information. Default is directory with SeatermV2 application data, when Data Conversion is launched from Seaterm232.

Instrument configuration (.xmlcon) file location, which is created by Seaterm232, and contains MicroCAT's calibration coefficients (see dialog box below).

Directory and file name for raw data (.hex) file created by Seaterm232 from uploaded data.

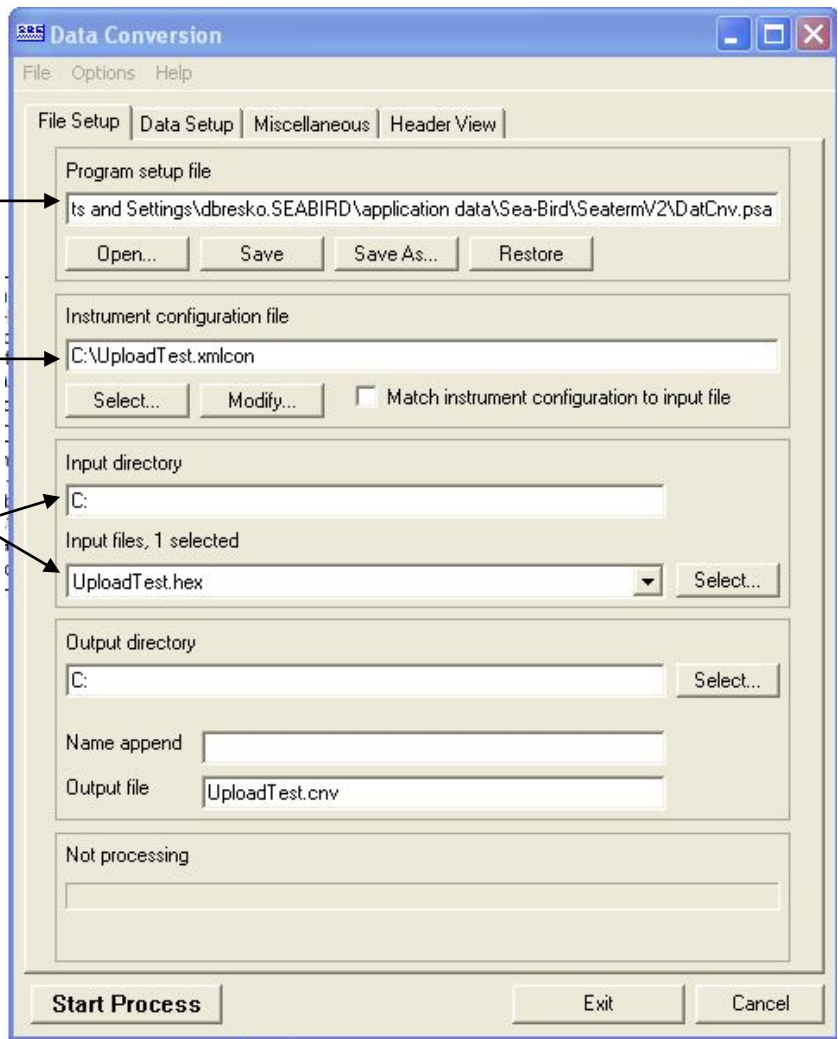

The Configuration dialog box (which appears if you click *Modify* on the File Setup tab) looks like this:

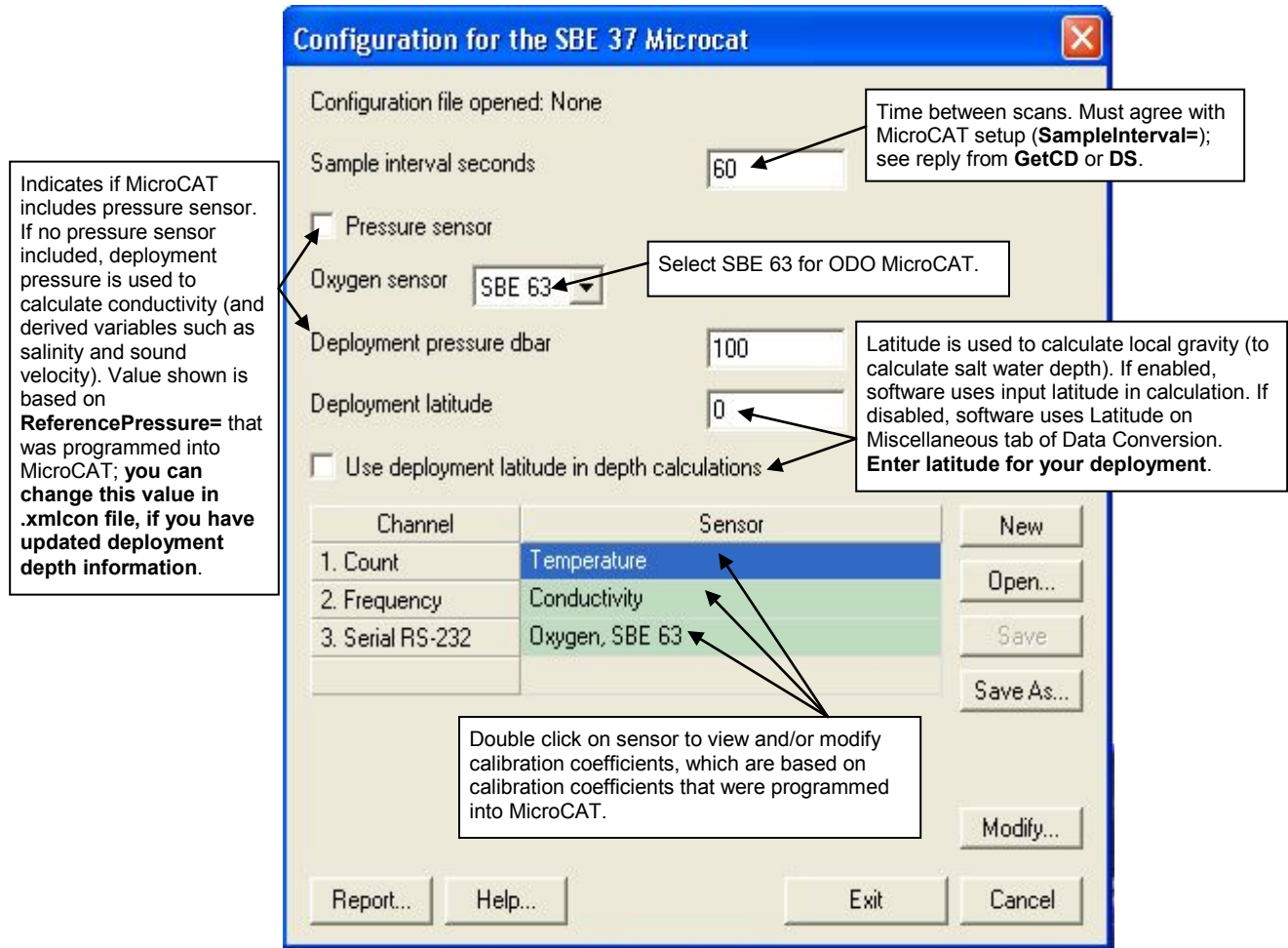

The settings in the .xmlcon file created by Seaterm232 are based on the setup of the MicroCAT.

- Review the deployment latitude, and modify as needed.
- If your MicroCAT does not have a pressure sensor, review the deployment pressure, and modify as needed.

Click Save if you made any changes, and then click Exit.

B. Click on the Data Setup tab.

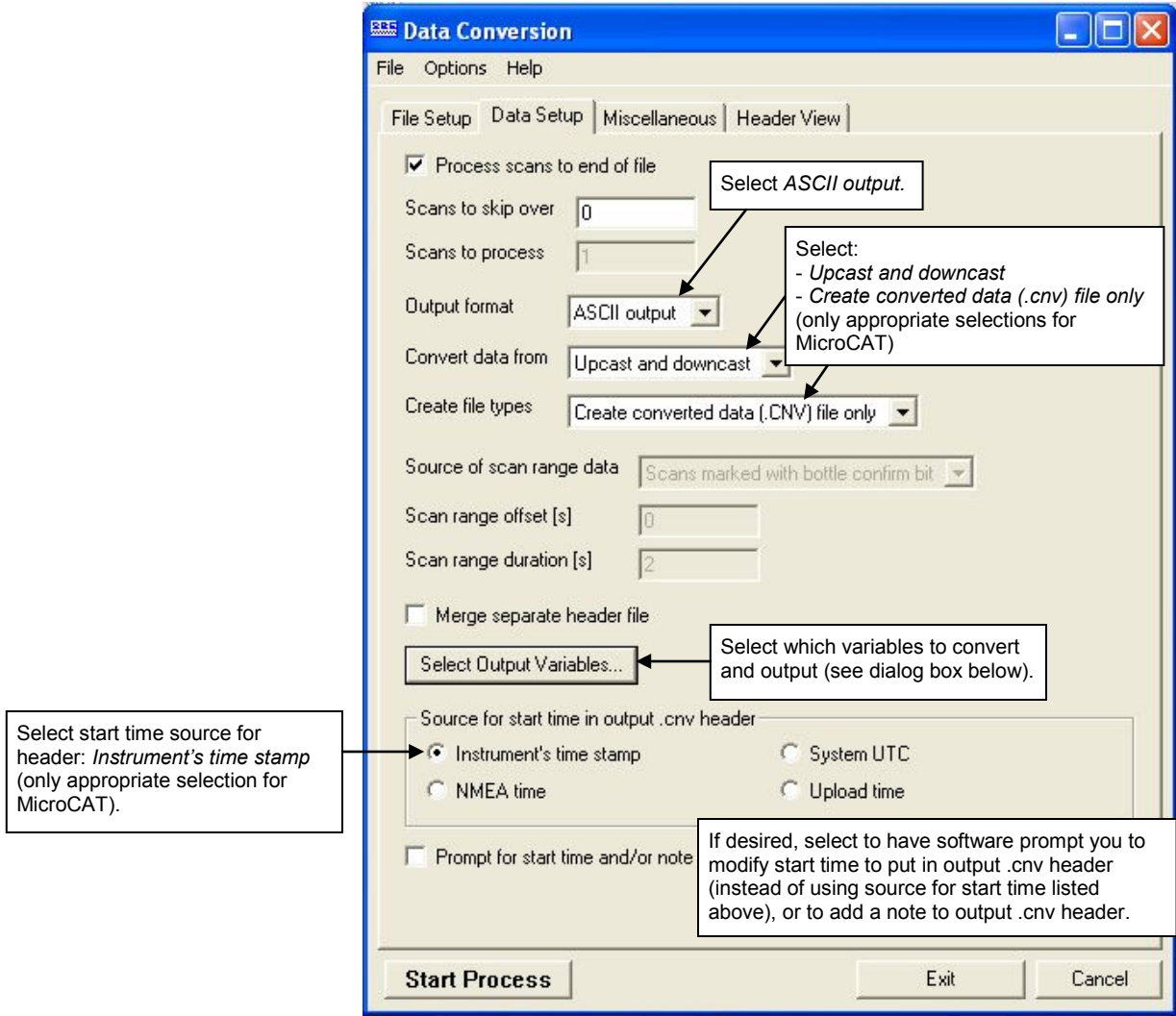

The Select Output Variables dialog box (which appears when you click *Select Output Variables* on the Data Setup tab) looks like this:

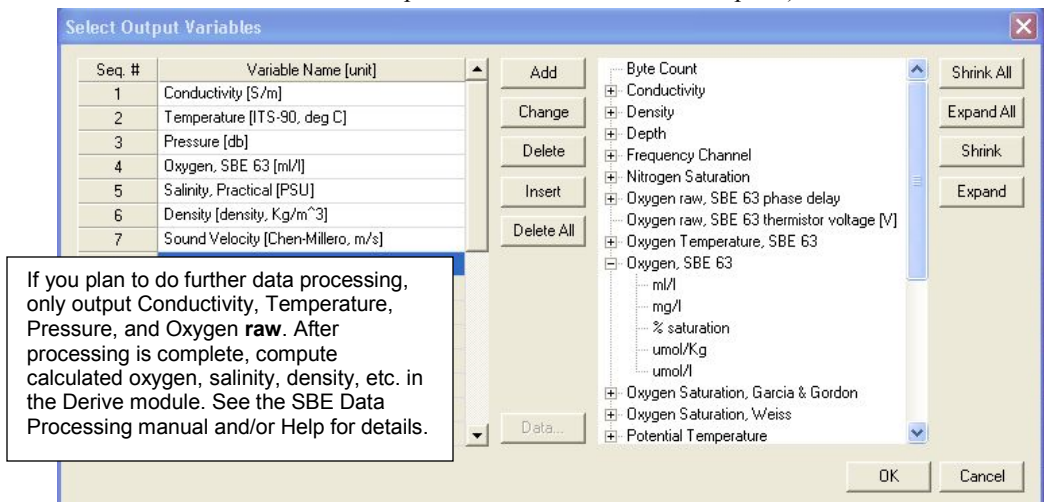

Select Temperature, Conductivity, Pressure (optional), and Oxygen as well as desired derived variables such as salinity, sound velocity, etc. Click OK.

C. At the bottom of the Data Conversion dialog box, click Start Process to convert the .hex file to a .cnv file.

Notes:

To prepare for re-deployment:

1. After all data has been uploaded, send **InitLogging**. If this is not sent, new data will be stored after the last sample, preventing use of the entire memory.
2. Do *one* of the following:
 - Send **QS** to put the MicroCAT in quiescent (sleep) state until ready to redeploy. Quiescent current is only 78 microAmps, so the battery pack can be left in place without significant loss of capacity.
 - Use **StartNow** to begin logging immediately.
 - Set a date and time for logging to start using **StartDateTime=** and **StartLater**.

11. Once the data is converted to a .cnv file, use the other SBE Data Processing modules as desired:
 - Derive module - Calculate additional derived variables.
 - Sea Plot module - Plot data.

Editing Raw Data File

Sometimes users want to edit the raw .hex data file before beginning processing, to remove data at the beginning of the file corresponding to instrument *soak* time, remove blocks of bad data, edit the header, or add explanatory notes.

Editing the raw .hex file can corrupt the data, making it impossible to perform further processing using Sea-Bird software. Sea-Bird strongly recommends that you first convert the data to a .cnv file (using the Data Conversion module in SBE Data Processing), and then use other SBE Data Processing modules to edit the .cnv file as desired.

Note:

Although we provide this technique for editing a raw .hex file, **Sea-Bird's strong recommendation, as described above, is to always convert the raw data file and then edit the converted file.**

The procedure described below for editing a .hex data file has been found to work correctly on computers running Windows 98, 2000, and NT. **If the editing is not performed using this technique, SBE Data Processing may reject the edited data file and give you an error message.**

1. **Make a back-up copy of your .hex data file before you begin.**
2. Run **WordPad**. In the File menu, select Open. The Open dialog box appears. For *Files of type*, select *All Documents (*.*)*. Browse to the desired .hex file and click Open.
3. Edit the file as desired, **inserting any new header lines after the System Upload Time line**. Note that all header lines must begin with an asterisk (*), and *END* indicates the end of the header. An example is shown below (for an SBE 21), with the added lines in bold:

```
* Sea-Bird SBE 21 Data File:
* FileName = C:\Odis\SAT2-ODIS\oct14-19\oc15_99.hex
* Software Version Seasave Win32 v1.10
* Temperature SN = 2366
* Conductivity SN = 2366
* System Upload Time = Oct 15 1999 10:57:19
* Testing adding header lines
* Must start with an asterisk
* Place anywhere between System Upload Time & END of header
* NMEA Latitude = 30 59.70 N
* NMEA Longitude = 081 37.93 W
* NMEA UTC (Time) = Oct 15 1999 10:57:19
* Store Lat/Lon Data = Append to Every Scan and Append to .NAV
File When <Ctrl F7> is Pressed
** Ship:          Sea-Bird
** Cruise:        Sea-Bird Header Test
** Station:
** Latitude:
** Longitude:
*END*
```
4. In the File menu, select Save (**not Save As**). If you are running Windows 2000, the following message displays:
You are about to save the document in a Text-Only format, which will remove all formatting. Are you sure you want to do this?
Ignore the message and click *Yes*.
5. In the File menu, select Exit.

Section 5: Routine Maintenance and Calibration

This section reviews corrosion precautions, connector mating and maintenance, conductivity cell cleaning and storage, plumbing maintenance, plastic housing handling instructions, replacement of AA cells, O-ring maintenance, pressure sensor maintenance, replacement of AF24173 Anti-Foulant Devices, and sensor calibration. The accuracy of the MicroCAT is sustained by the care and calibration of the sensors and by establishing proper handling practices.

Corrosion Precautions

Rinse the MicroCAT with fresh water after use and prior to storage.

All exposed metal is titanium; other materials are plastic. No corrosion precautions are required, but direct electrical connection of the MicroCAT housing to mooring or other dissimilar metal hardware should be avoided.

Connector Mating and Maintenance

Note:

See *Application Note 57: Connector Care and Cable Installation*.

CAUTIONS:

- **Do not use WD-40** or other petroleum-based lubricants, as they will damage the connectors.
- For wet-pluggable MCBH connectors: **Silicone lubricants in a spray can** may contain ketones, esters, ethers, alcohols, or glycols in their propellant. **Do not use these sprays, as they will damage the connector.**

Clean and inspect the connectors, cable, and dummy plug before every deployment and as part of your yearly equipment maintenance. Inspect connectors that are unmated for signs of corrosion product around the pins, and for cuts, nicks or other flaws that may compromise the seal.

When remating:

1. Lightly lubricate the inside of the dummy plug/cable connector with silicone grease (DC-4 or equivalent).
2. Install the plug/cable connector, aligning the pins.
3. Place the locking sleeve over the plug/cable connector. Tighten the locking sleeve finger tight only. **Do not overtighten the locking sleeve and do not use a wrench or pliers.**

Verify that a cable or dummy plug is installed on the MicroCAT before deployment.

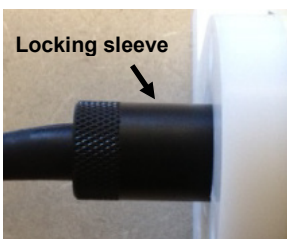
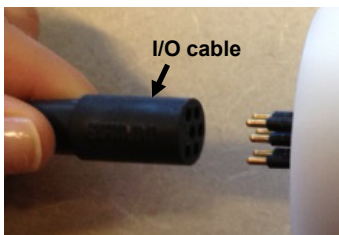

Conductivity Cell and Dissolved Oxygen Sensor Maintenance

CAUTIONS:

- **Do not put a brush or any object inside the plumbing to clean it.** Touching and bending conductivity cell electrodes can change the calibration; large bends /movement of the electrodes can damage the cell. Touching or wiping the oxygen sensor window can damage it.
- **Do not store with water in the plumbing.** Freezing temperatures (for example, Arctic environments or during air shipment) can break the conductivity cell or damage the oxygen sensor if it is full of water.

The MicroCAT's conductivity cell, plumbing, and oxygen sensor plenum is shipped dry to prevent freezing in shipping.

Refer to *Application Note 2D: Instructions for Care and Cleaning of Conductivity Cells* for conductivity cell cleaning procedures and cleaning materials.

- The Active Use (after each cast) section of the application note is not applicable to the MicroCAT, which is intended for use as a moored instrument.

Refer to the *SBE 63 manual for cleaning and storage procedures and materials*.

- **Prolonged exposure of the dissolved oxygen sensor optical window to Triton X-100 may be harmful.** Because the conductivity cell and oxygen sensor are integrated in this instrument, we recommend use of the dissolved oxygen sensor cleaning and storage instructions for the entire plumbing system; **do not use cleaning and storage instructions for the conductivity cell (these could damage the oxygen sensor).**

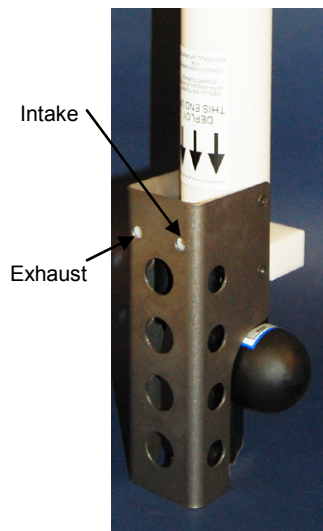

To rinse or fill the conductivity cell, dissolved oxygen plenum, pump, and plumbing:

- Hold or clamp the MicroCAT with the connector end up, so that the plumbing is in a U-shape.
- Pour the water or solution through the plumbing with a syringe or wash bottle.

Plumbing Maintenance



A clogged bleed hole can trap air, preventing the pump from functioning properly; this will affect the data quality. Before each deployment, clean the bleed hole with 0.4 mm (0.016 inch) diameter (#26 AWG) wire; a wire is included in the spares kit that ships with the MicroCAT. Insert the wire 13 mm (0.5 inches) into the hole to clean it; verify it is clear by spraying water into the hole.

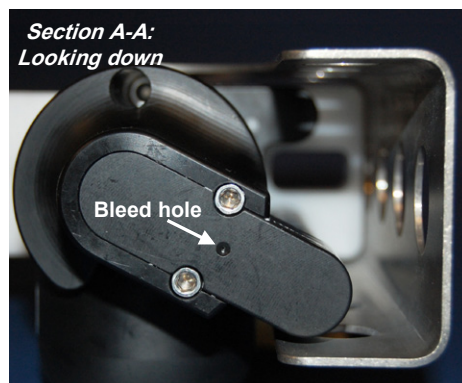

Handling Instructions for Plastic *ShallowCAT*



See detail below

Cap screw securing connector end cap (one each side)



Detail - Connector end cap

To get excellent performance and longevity for the plastic housing:

- The MicroCAT's connector end cap is retained by two screws through the side of the housing. The screw holes are close to the end of the housing. Particularly in a cold environment, where plastic is more brittle, the potential for developing a crack around the screw hole(s) is greater for the plastic housing than for a titanium housing. Observe the following precautions –
 - When removing the end cap (to replace the AA cells and/or to access the electronics), be careful to avoid any impact in this area of the housing.
 - When reinstalling the end cap, do not use excess torque on the screws. Sea-Bird recommends tightening the screws to 15 inch-lbs. Alternatively, tighten the screws finger-tight, and then turn each screw an additional 45 degrees.
- A plastic housing is more susceptible to scratches than a titanium housing. Do not use screwdrivers or other metal tools to pry off the end cap.
 - Of primary concern are scratches on O-ring mating and sealing surfaces. Take extra precaution to avoid a scraping contact with these surfaces when replacing AA cells and/or re-seating the end cap.
 - Also take care to keep the O-ring lubricated surfaces clean – avoid trapping any sand or fine grit that can scratch the critical sealing surfaces. If the O-ring lubricant does accumulate any material or grit that can cause a leak or make a scratch, it must be carefully cleaned and replaced with fresh, clean lubricant (Parker Super O Lube).
 - Shallow, external scratches are cosmetic only, and will not affect the performance of the MicroCAT. However, deep external scratches can become points of weakness for deep deployments or fracture from impact during very cold weather.
- If you remove the screws securing the conductivity cell guard to the housing (for example, to change the Anti-Foulant Devices), follow the same precautions as described above for removing and replacing the connector end cap.

See *Battery Pack Installation* in *Section 3: Preparing MicroCAT for Deployment* and *Appendix II: Electronics Disassembly / Reassembly* for detailed step-by-step procedures for removing the MicroCAT's end cap.

Replacing AA Cells

Notes:

- For details and photos, see *Installing Battery Pack* in *Section 3: Preparing MicroCAT for Deployment*.
- **Only use the battery pack with the yellow cover plate.** Older MicroCATs without dissolved oxygen use a battery pack with a red cover plate; the wiring of that pack is different from this one, and will not work properly in the 37-SMP-ODO.
- Cells must be removed before returning the MicroCAT to Sea-Bird. Do not return used cells to Sea-Bird when shipping the MicroCAT for calibration or repair.

1. Remove the 2 cap screws holding the I/O connector end cap to the MicroCAT housing. Remove the I/O end cap by twisting the end cap counter clockwise; the end cap will release from the housing. Pull the end cap out.
2. Loosen the captured screw holding the battery pack in the housing, and remove the battery pack from the housing.
3. Place the handle in an upright position. Unscrew the **yellow** cover plate from the top of the battery pack assembly.
4. Roll the 2 O-rings on the outside of the pack out of their grooves.
5. Remove the existing cells. Install new cells, **alternating** positive (+) end first and negative (-) end first to match the labels on the pack.
6. Roll the O-rings into place in the grooves on the side of the battery pack.
7. Place the handle in an upright position. Reinstall the battery pack cover plate.
8. Replace the battery pack assembly in the housing, and secure the assembly with the captured screw. Plug in the Molex connector. Reinstall the MicroCAT end cap, and secure with the 2 cap screws.

O-Ring Maintenance

Note:

For details on recommended practices for cleaning, handling, lubricating, and installing O-rings, see the *Basic Maintenance of Sea-Bird Equipment* module in the Sea-Bird training materials: www.seabird.com/training/TrainingHandouts.htm.

Recommended inspection and replacement schedule:

- For connector end cap O-rings – inspect each time you open the housing to replace the cells; replace approximately once a year.
- For O-rings that are not normally disturbed (for example, on the electronics end cap) - approximately every 3 to 5 years.

Remove any water from the O-rings and mating surfaces in the housing with a lint-free cloth or tissue. Inspect O-rings and mating surfaces for dirt, nicks, and cuts. Clean or replace as necessary. Apply a light coat of O-ring lubricant (Parker Super O Lube) to O-rings and mating surfaces.

Pressure Sensor (optional) Maintenance

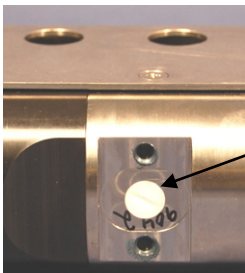

Pressure port plug

The pressure port is located behind the mount clamp. The pressure port plug has a small vent hole to allow hydrostatic pressure to be transmitted to the pressure sensor inside the instrument, while providing protection for the pressure sensor, keeping most particles and debris out of the pressure port.

Periodically (approximately once a year) inspect the pressure port to remove any particles, debris, etc:

1. Unscrew the pressure port plug from the pressure port.
2. Rinse the pressure port with warm, de-ionized water to remove any particles, debris, etc.
3. Replace the pressure port plug.

CAUTION:

Do not put a brush or any object in the pressure port. Doing so may damage or break the pressure sensor.

Replacing Anti-Foulant Devices – Mechanical Design Change

CAUTIONS:

- Be careful not to damage the glass conductivity cell or the thermistor when removing / replacing Anti-Foulant Devices.
- See *Handling Instructions for Plastic ShallowCAT*.

The AF24173 Anti-Foulant Devices are installed at the intake and the pump exhaust. Details are provided below on replacing the AF24173 Anti-Foulant Devices. This page provides the mechanical details for the SBE 37-SMP-ODO MicroCAT. The following page, developed for a MicroCAT that does not include an integral pump or dissolved oxygen sensor, provides the precautions and handling details.

1. Remove the 4 Phillips-head screws holding the conductivity cell guard to the housing. Carefully remove the cell guard.
2. Remove and replace the Anti-Foulant Devices.
3. Carefully replace the cell guard, securing it to the housing with the 4 Phillips-head screws.

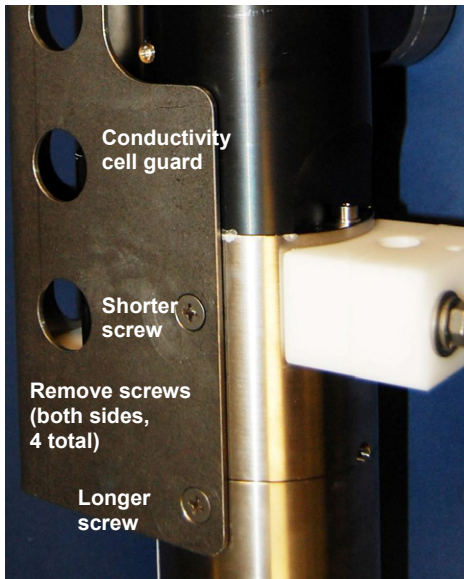

Shown with conductivity cell guard removed

Replacing Anti-Foulant Devices (SBE 37-SI, SM, IM)



AF24173
Anti-Foulant
Device

The MicroCAT has an anti-foulant device cup and cap on each end of the cell. New MicroCATs are shipped with an Anti-Foulant Device and a protective plug pre-installed in each cup.

WARNING!

AF24173 Anti-Foulant Devices contain bis(tributyltin) oxide. Handle the devices only with rubber or latex gloves. Wear eye protection. Wash with soap and water after handling.

Read precautionary information on product label (see Appendix IV) before proceeding.

It is a violation of US Federal Law to use this product in a manner inconsistent with its labeling.

Wearing rubber or latex gloves, follow this procedure to replace each Anti-Foulant Device (two):

1. Remove the protective plug from the anti-foulant device cup;
2. Unscrew the cap with a $\frac{5}{8}$ -inch socket wrench;
3. Remove the old Anti-Foulant Device. If the old device is difficult to remove:

- Use needle-nose pliers and carefully break up material;
- If necessary, remove the guard to provide easier access.

Place the new Anti-Foulant Device in the cup;

4. Rethread the cap onto the cup. Do not over tighten;
5. If the MicroCAT is to be stored, reinstall the protective plug. **Note that the plugs must be removed prior to deployment or pressurization.** If the plugs are left in place during deployment, the cell will not register conductivity. If left in place during pressurization, the cell may be destroyed.

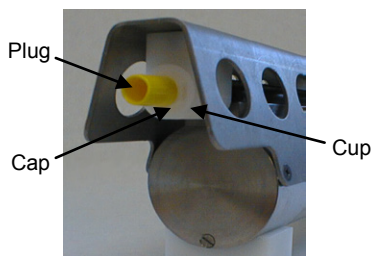
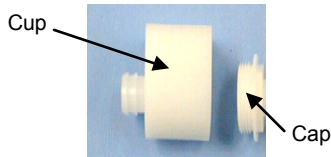

CAUTION:

Anti-foulant device cups are attached to the guard and connected with tubing to the cell. **Removing the guard without disconnecting the cups from the guard will break the cell.** If the guard must be removed:

1. Remove the two screws connecting each anti-foulant device cup to the guard.
2. Remove the four Phillips-head screws connecting the guard to the housing and sensor end cap.
3. Gently lift the guard away.

Sensor Calibration

Notes:

- Cells must be removed before returning the MicroCAT to Sea-Bird. Do not return used cells to Sea-Bird when shipping the MicroCAT for recalibration or repair.
- Please remove AF24173 Anti-Foulant Devices from the anti-foulant device cup before returning the MicroCAT to Sea-Bird. Store them for future use. See *Replacing Anti-Foulant Devices* for removal procedure.

Sea-Bird sensors are calibrated by subjecting them to known physical conditions and measuring the sensor responses. Coefficients are then computed, which may be used with appropriate algorithms to obtain engineering units. The sensors on the MicroCAT are supplied fully calibrated, with coefficients printed on their respective Calibration Certificates (see back of manual). These coefficients have been stored in the MicroCAT's EEPROM.

We recommend that MicroCATs be returned to Sea-Bird for calibration.

Conductivity Sensor Calibration

The conductivity sensor incorporates a fixed precision resistor in parallel with the cell. When the cell is dry and in air, the sensor's electrical circuitry outputs a frequency representative of the fixed resistor. This frequency is recorded on the Calibration Certificate and should remain stable (within 1 Hz) over time.

The primary mechanism for calibration drift in conductivity sensors is the fouling of the cell by chemical or biological deposits. Fouling changes the cell geometry, resulting in a shift in slope. Accordingly, the most important determinant of long-term sensor accuracy is the cleanliness of the cell. We recommend that the conductivity sensor be calibrated before and after deployment, but particularly when the cell has been exposed to contamination by oil slicks or biological material.

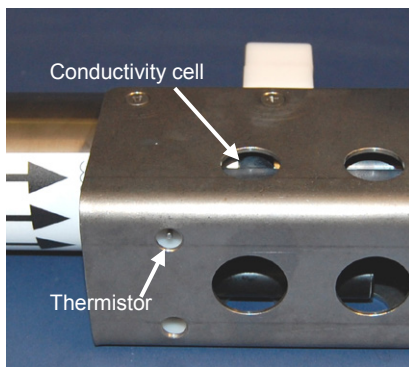

Temperature Sensor Calibration

The primary source of temperature sensor calibration drift is the aging of the thermistor element. Sensor drift will usually be a few thousandths of a degree during the first year, and less in subsequent intervals. Sensor drift is not substantially dependent upon the environmental conditions of use, and — unlike platinum or copper elements — the thermistor is insensitive to shock.

Dissolved Oxygen Sensor Calibration

The primary mechanism for calibration drift in optical oxygen sensors is the fouling of the optical window by chemical or biological deposits. Accordingly, the most important determinant of long-term sensor accuracy is the cleanliness of the window. We recommend that oxygen sensors be calibrated before and after deployment, but particularly when the sensor has been exposed to contamination by oil slicks or biological material.

Another important mechanism for oxygen sensor drift is photobleaching of the sensor film. Keep the SBE 63 sensor film out of direct sunlight if detached from the main body of the MicroCAT. Also, every sample that is taken illuminates the film with short wavelength light that eventually degrades the film. As a rule of thumb, re-calibration of the oxygen sensor on the MicroCAT is recommended when enough samples are taken to fill the MicroCAT's memory (300,000 to 500,000 samples).

Pressure Sensor (optional) Calibration

The optional strain-gauge pressure sensor is a mechanical diaphragm type, with an initial static error band of 0.05%. Consequently, the sensor is capable of meeting the MicroCAT's 0.10% error specification with some allowance for aging and ambient-temperature induced drift.

Pressure sensors show most of their error as a linear offset from zero.

A technique is provided below for making small corrections to the pressure sensor calibration using the *offset* (**POffset=**) calibration coefficient term by comparing MicroCAT pressure output to readings from a barometer.

Allow the MicroCAT to equilibrate in a reasonably constant temperature environment for at least 5 hours before starting. Pressure sensors exhibit a transient change in their output in response to changes in their environmental temperature. Sea-Bird instruments are constructed to minimize this by thermally decoupling the sensor from the body of the instrument. However, there is still some residual effect; allowing the MicroCAT to equilibrate before starting will provide the most accurate calibration correction.

Note:

The MicroCAT's pressure sensor is an absolute sensor, so its **raw** output (**OutputFormat=0**) includes the effect of atmospheric pressure (14.7 psi). As shown on the Calibration Sheet, Sea-Bird's calibration (and resulting calibration coefficients) is in terms of psia. However, when outputting pressure in **psi** or **decibars**, the MicroCAT outputs pressure relative to the ocean surface (i.e., at the surface the output pressure is 0 psi or 0 dbar). The MicroCAT uses the following equations to convert psia:

$$P \text{ (psi)} = P \text{ (psia)} - 14.7$$

$$P \text{ (dbar)} = [P \text{ (psia)} - 14.7] * 0.689476$$

1. Place the MicroCAT in the orientation it will have when deployed.
2. In Seaterm232:
 - A. Set the pressure offset to 0.0 (**POffset=0**).
 - B. Set the output format to converted decimal (**OutputFormat=1**), enable pressure output (**OutputPress=y**), and set pressure output units to decibars (**SetPressUnits=0**).
 - C. Send **TSN:100** to take 100 samples and transmit data.
3. Compare the MicroCAT output to the reading from a good barometer at the same elevation as the MicroCAT's pressure sensor port. Calculate *offset* = barometer reading – MicroCAT reading
4. Enter the calculated offset (positive or negative) in the MicroCAT's EEPROM, using **POffset=** in Seaterm232.

Offset Correction Example

Absolute pressure measured by a barometer is 1010.50 mbar. Pressure displayed from MicroCAT is -2.5 dbar.

Convert barometer reading to dbar using the relationship: mbar * 0.01 = dbar

Barometer reading = 1010.50 mbar * 0.01 = 10.1050 dbar

The MicroCAT's internal calculations output gauge pressure, using an assumed value of 14.7 psi for atmospheric pressure. Convert MicroCAT reading from gauge to absolute by adding 14.7 psia to the MicroCAT's output:

$$-2.5 \text{ dbar} + (14.7 \text{ psi} * 0.689476 \text{ dbar/psia}) = -2.5 + 10.13 = 7.635 \text{ dbar}$$

$$\text{Offset} = 10.1050 - 7.635 = + 2.47 \text{ dbar}$$

Enter offset in MicroCAT.

For demanding applications, or where the sensor's air ambient pressure response has changed significantly, calibration using a dead-weight generator is recommended. The pressure sensor port uses a ⁷/₁₆-20 straight thread for mechanical connection to the pressure source. Use a fitting that has an O-ring tapered seal, such as Swagelok-200-1-4ST, which conforms to MS16142 boss.

Section 6: Troubleshooting

This section reviews common problems in operating the MicroCAT, and provides the most common causes and solutions.

Problem 1: Unable to Communicate with MicroCAT

If **OutputExecutedTag=N**, the `S>` prompt indicates that communications between the MicroCAT and computer have been established. Before proceeding with troubleshooting, attempt to establish communications again by selecting *Connect* in the Communications menu in Seaterm232 or pressing the Enter key several times.

Cause/Solution 1: The I/O cable connection may be loose. Check the cabling between the MicroCAT and computer for a loose connection.

Cause/Solution 2: The instrument communication settings may not have been entered correctly in Seaterm232. Verify the settings in the Serial Port Configuration dialog box (Communications menu -> *Configure*). The settings should match those on the instrument Configuration Sheet.

Cause/Solution 3: The I/O cable between the MicroCAT and computer may not be the correct one. The I/O cable supplied with the MicroCAT permits connection to standard 9-pin RS-232 interfaces.

Problem 2: No Data Recorded

Cause/Solution 1: The memory may be full; once the memory is full, no further data will be recorded. Verify that the memory is not full using **GetSD** or **DS** (*free = 0* or *1* if memory is full). Sea-Bird recommends that you upload all previous data before beginning another deployment. Once the data is uploaded, send **InitLogging** to reset the memory. After the memory is reset, **GetSD** or **DS** will show *samples = 0*.

Problem 3: Unreasonable T, C, P, or D.O. Data

The symptom of this problem is a data file that contains unreasonable values (for example, values that are outside the expected range of the data).

Cause/Solution 1: A data file with unreasonable (i.e., out of the expected range) values for temperature, conductivity, pressure, or dissolved oxygen may be caused by incorrect calibration coefficients in the MicroCAT. Send **GetCC** to verify the calibration coefficients in the MicroCAT match the instrument Calibration Certificates. Note that calibration coefficients do not affect the raw data stored in MicroCAT memory.

- If you have not yet overwritten the memory with new data, you can correct the coefficients and then upload the data again.
- If you have overwritten the memory with new data, you can manually correct the coefficients in the .xmlcon configuration file, and then reprocess the data in SBE Data Processing's Data Conversion module.

Cause/Solution 2: Minimal changes in **conductivity** are an indication that the pump flow is not correct. Poor flushing can have several causes:

- Air in the plumbing may be preventing the pump from priming. This can result from:
 - A clogged air bleed hole; clean the air bleed hole (see *Plumbing Maintenance* in *Section 5: Routine Maintenance and Calibration*).
 - Incorrect orientation for a shallow deployment in a location with breaking waves; see *Optimizing Data Quality / Deployment Orientation* in *Section 4: Deploying and Operating MicroCAT*.
- The pump may be clogged by sediment. Using a wash bottle, flush the plumbing to attempt to dislodge the sediment. If the sediment is impacted and you cannot flush it, return the MicroCAT to Sea-Bird for servicing. To minimize ingestion of sediment for future deployments, see *Optimizing Data Quality / Deployment Orientation* in *Section 4: Deploying and Operating MicroCAT*.
- The pump may not be turning on before each sample, if **MinCondFreq=** is set too high. See *Command Descriptions* in *Section 4: Deploying and Operating MicroCAT* for details.

Problem 4: Salinity Spikes

Salinity is a function of conductivity, temperature, and pressure, and must be calculated from C, T, and P measurements made on the same parcel of water. Salinity is calculated and output by the 37-SMP-ODO if **OutputSal=Y**. Alternatively, salinity can be calculated in SBE Data Processing's Data Conversion module from the data uploaded from memory (.hex file) or in SBE Data Processing's Derive module from the converted (.cnv) file.

[*Background information:* Salinity spikes in **profiling** (i.e., moving, fast sampling) instruments typically result from misalignment of the temperature and conductivity measurements in conditions with sharp gradients. This misalignment is often caused by differences in response times for the temperature and conductivity sensors, and can be corrected for in post-processing if the T and C response times are known.]

In **moored**, pumped instruments such as the 37-SMP-ODO SDI-12 MicroCAT, the pump flushes the conductivity cell at a faster rate than the environment changes, so the T and C measurements stay closely synchronized with the environment (i.e., even slow or varying response times are not significant factors in the salinity calculation). More typical causes of salinity spikes in a moored 37-SMP-ODO include:

Cause/Solution 1: Severe external bio-fouling can restrict flow through the conductivity cell to such an extent that the conductivity measurement is significantly delayed from the temperature measurement.

Cause/Solution 2: For a MicroCAT moored at shallow depth, differential solar heating can cause the actual temperature inside the conductivity cell to differ from the temperature measured by the thermistor. Salinity spikes associated mainly with daytime measurements during sunny conditions may be caused by this phenomenon.

Cause/Solution 3: For a MicroCAT moored at shallow depth, air bubbles from breaking waves or spontaneous formation in supersaturated conditions can cause the conductivity cell to read low of correct.

Glossary

Note:

The 37-SMP-ODO battery pack has a **yellow** cover plate. **Older MicroCATs without dissolved oxygen use a battery pack with a red cover plate; the wiring of that pack is different from this one, and cannot be used with the 37-SMP-ODO.**

Note:

All Sea-Bird software listed was designed to work with a computer running Windows XP service pack 2 or later, Windows Vista, or Windows 7.

Note:

IDO MicroCATs are integrated with SBE 43F DO sensors (Clark polarographic membrane type). **ODO** MicroCATs are integrated with SBE 63 Optical DO sensors.

Battery pack – 12 AA lithium cells in a battery holder that connects 4 cells in series and each series string in parallel. Battery pack uses:

- Saft LS 14500, AA, 3.6 V and 2.6 Amp-hours each (www.saftbatteries.com) (**recommended**),
- Tadiran TL-4903, AA, 3.6 V and 2.4 Amp-hours each (www.tadiran.com), or
- Electrochem 3B0064/BCX85, AA, 3.9 V and 2.0 Amp-hours each (www.electrochemsolutions.com)

Deployment Endurance Calculator – Sea-Bird’s Windows software used to calculate deployment length for moored instruments, based on user-input deployment scheme, instrument power requirements, and battery capacity.

Fouling – Biological growth in the conductivity cell and in the oxygen sensor plenum during deployment.

MicroCAT (SBE 37) – High-accuracy conductivity, temperature, and optional pressure Recorder/Monitor. A number of models are available:

- 37-IM (**I**nductive **M**odem, internal battery pack and memory)
- 37-IMP (**I**nductive **M**odem, internal battery pack and memory, integral **P**ump)
- 37-IMP-IDO (**I**nductive **M**odem, internal battery pack and memory, integral **P**ump, **I**ntegrated **D**issolved **O**xygen sensor) – includes internal RS-232 interface
- 37-IMP-ODO (**I**nductive **M**odem, internal battery pack and memory, integral **P**ump, **O**ptical **D**issolved **O**xygen sensor) – includes internal RS-232 interface
- 37-SM (**S**erial interface, internal battery pack and **M**emory)
- 37-SMP (**S**erial interface, internal battery pack and **M**emory, integral **P**ump)
- 37-SMP-IDO (**S**erial interface, internal battery pack and **M**emory, integral **P**ump, **I**ntegrated **D**issolved **O**xygen sensor)
- 37-SMP-ODO (**S**erial interface, internal battery pack and **M**emory, integral **P**ump, **O**ptical **D**issolved **O**xygen sensor)
- 37-SI (**S**erial **I**nterface, memory, no internal battery pack) *
- 37-SIP (**S**erial **I**nterface, integral **P**ump, memory, no internal battery pack) *
- 37-SIP-IDO (**S**erial **I**nterface, integral **P**ump, **I**ntegrated **D**issolved **O**xygen sensor, memory, no internal battery pack)
- 37-SIP-ODO (**S**erial **I**nterface, integral **P**ump, **O**ptical **D**issolved **O**xygen sensor, memory, no internal battery pack)

The serial interface versions are available with RS-232 or RS-485 interface.

Some serial interface versions are also available with an SDI-12 interface.

* Note: Version 3.0 and later of the 37-SI and 37-SIP include memory; earlier versions did not include memory.

PCB – Printed Circuit Board.

SBE Data Processing - Sea-Bird’s Windows data processing software, which calculates and plots temperature, conductivity, oxygen, and optional pressure, and derives variables such as salinity and sound velocity.

Scan – One data sample containing temperature, conductivity, optional pressure, oxygen, and date and time, as well as optional derived variables (salinity, sound velocity, specific conductivity).

Seasoft V2 – Sea-Bird’s Windows software package, which includes software for communication, real-time data acquisition, and data analysis and display. Seasoft V2 includes *Deployment Endurance Calculator*, *SeatermV2*, and *SBE Data Processing*.

SeatermV2 – Windows terminal program *launcher*, which launches the appropriate terminal program for the selected instrument (Seaterm232 for this MicroCAT).

Seaterm232 – Windows terminal program used with Sea-Bird instruments that communicate via an RS-232 interface, and that were developed or redesigned in 2006 and later. The common feature of these instruments is the ability to output data in XML.

Super O-Lube – Silicone lubricant used to lubricate O-rings and O-ring mating surfaces. Super O-Lube can be ordered from Sea-Bird, but should also be available locally from distributors. Super O-Lube is manufactured by Parker Hannifin (www.parker.com/ead/cm2.asp?cmid=3956).

TCXO – Temperature Compensated Crystal Oscillator.

Triton X-100 – Reagent grade non-ionic surfactant (detergent), used for cleaning the conductivity cell. Triton can be ordered from Sea-Bird, but should also be available locally from chemical supply or laboratory products companies. Triton is manufactured by Avantor Performance Materials (www.avantormaterials.com/commerce/product.aspx?id=2147509608).

Appendix I: Functional Description

Sensors

The MicroCAT embodies the same sensor elements (3-electrode, 2-terminal, borosilicate glass cell, and pressure-protected thermistor) previously employed in our modular SBE 3 and SBE 4 sensors and in the SeaCAT and SeaCAT*plus* family.

Note:

Pressure ranges are expressed in meters of deployment depth capability.

The MicroCAT's optional strain-gauge pressure sensor is available in the following pressure ranges: 20, 100, and 350 meters. Compensation of the temperature influence on pressure offset and scale is performed by the MicroCAT's CPU.

The Optical Dissolved Oxygen sensor is an SBE 63 Dissolved Oxygen sensor, with the same performance specifications.

Sensor Interface

Temperature is acquired by applying an AC excitation to a hermetically sealed VISHAY reference resistor and an ultra-stable aged thermistor with a drift rate of less than 0.002°C per year. A 24-bit A/D converter digitizes the outputs of the reference resistor and thermistor (and optional pressure sensor). AC excitation and ratiometric comparison using a common processing channel avoids errors caused by parasitic thermocouples, offset voltages, leakage currents, and reference errors.

Conductivity is acquired using an ultra-precision Wien Bridge oscillator to generate a frequency output in response to changes in conductivity.

Real-Time Clock

To minimize power and improve clock accuracy, a temperature-compensated crystal oscillator (TCXO) is used as the real-time-clock frequency source. The TCXO is accurate to ± 1 minute per year (0 °C to 40 °C).

Appendix II: Electronics Disassembly/Reassembly

CAUTION:

See Section 5: Routine Maintenance and Calibration for handling instructions for the plastic ShallowCAT housing.

Disassembly:

1. Remove the connector end cap and battery pack following instructions in Section 3: Preparing MicroCAT for Deployment.
2. Remove two screws connecting the conductivity cell guard to the housing. Put one of the removed end cap screws in the machined detail. Remove the housing by twisting the housing counter clockwise; the housing will release.

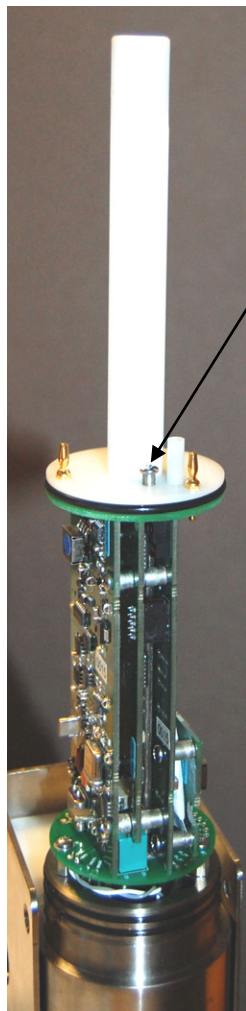
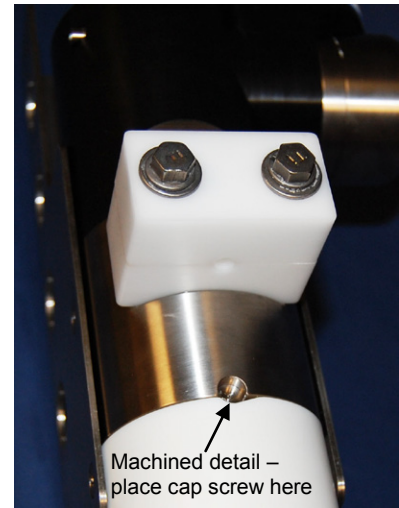
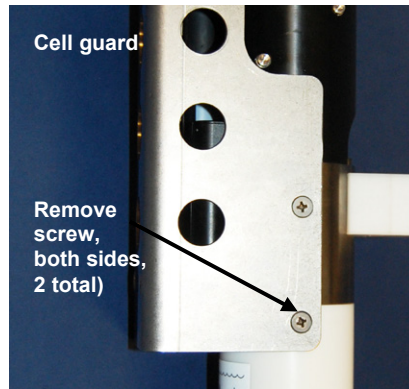

3. The electronics are on a sandwich of three rectangular PCBs. These PCBs are assembled to a bulkhead. To remove the PCB assembly:
 - A. Use a long screwdriver (#1 screwdriver) to remove the Phillips-head screw. The Phillips-head screw is a 198 mm (7.8 inch) threaded rod with Phillips-head.
 - B. Pull out the PCB assembly using the pylon (post with connector). The assembly will pull away from the edge connector used to connect to the sensors. If needed, pull the sandwich of three rectangular PCBs from the bulkhead.

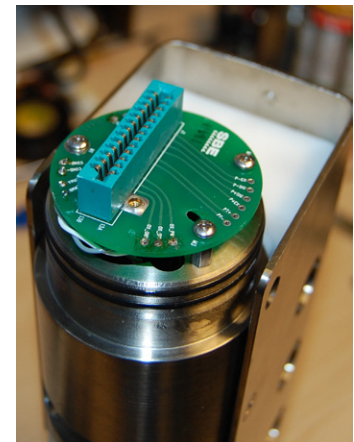
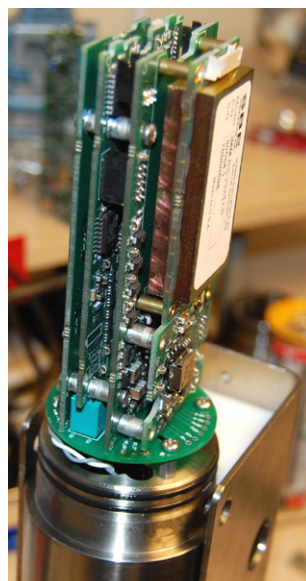

Reassembly:**Note:**

If the rod will not tighten, the PCBs have not fully mated or are mated in reverse.

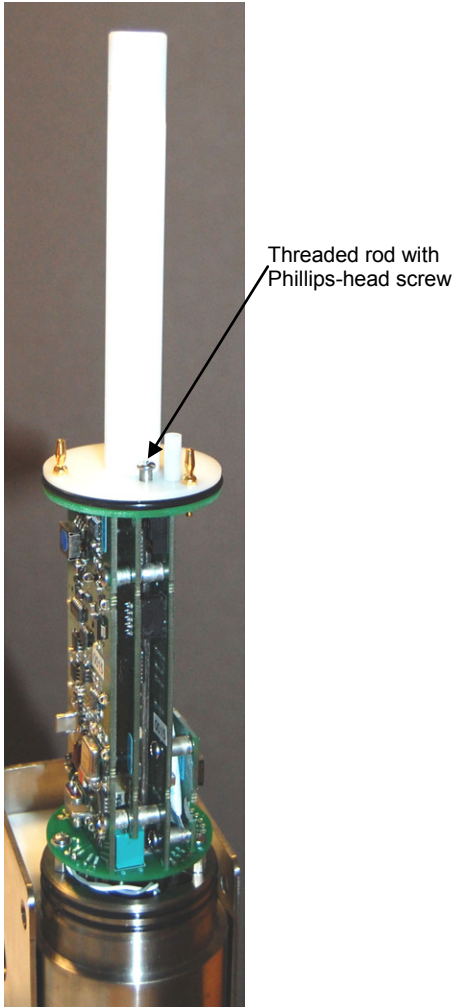

1. Replace all the components as shown at left. Tighten gently the threaded rod with Phillips-head screw. A gentle resistance can be felt as the PCB assembly mates to the edge connector.

2. Replace the housing on the end cap:
 - A. Remove any water from the O-rings and mating surfaces with a lint-free cloth or tissue. Inspect the O-rings and mating surfaces for dirt, nicks, and cuts. Clean as necessary. Apply a light coat of O-ring lubricant (Parker Super O Lube) to the O-rings and mating surfaces.
 - B. Carefully fit the housing onto the housing until the O-rings are fully seated.
 - C. Reinstall the two Phillips-head screws to secure the housing.
3. Reinstall the battery pack and end cap following instructions in *Section 3: Preparing MicroCAT for Deployment*.

Note:

Before delivery, a desiccant package is inserted in the housing and the electronics chamber is filled with dry Argon gas. These measures help prevent condensation. To ensure proper functioning:

1. Install a new desiccant bag each time you open the electronics chamber. If a new bag is not available, see *Application Note 71: Desiccant Use and Regeneration (drying)*.
2. If possible, dry gas backfill each time you open the housing. If you cannot, wait at least 24 hours before redeploying, to allow the desiccant to remove any moisture from the housing.

Note that opening the battery compartment does not affect desiccation of the electronics.

Appendix III: Command Summary

Note:
See *Command Descriptions* in *Section 4: Deploying and Operating MicroCAT* for detailed information and examples.

CATEGORY	COMMAND	DESCRIPTION
Status	GetCD	Display configuration data.
	GetSD	Display status data.
	GetCC	Display calibration coefficients.
	GetEC	Display event counter data.
	ResetEC	Reset event counter.
	GetHD	Display hardware data.
	Help	Display list of currently available commands.
	DS	Display status and configuration data.
General Setup	DC	Display calibration coefficients.
	DateTime= mmdyyyhmmss	Set real-time clock month, day, year, hour, minute, second.
	BaudRate=x	x= baud rate for RS-232 communications (4800, 9600, 19200, 38400, 57600, or 115200). Default 9600. <i>Note: 1200 baud is used for SDI-12 communication, and is independent of baud set for RS-232 communication.</i>
	ReferencePressure=x	x= reference pressure (gauge) in decibars (used for conductivity (and optional salinity and sound velocity) computation and for <i>Adaptive Pump Control</i> algorithm when MicroCAT does not have pressure sensor).
RS-232 Setup	QS	Enter quiescent (sleep) state. Main power turned off, but data logging and memory retention unaffected.
	OutputExecutedTag=x	x=Y: Display XML Executing and Executed tags for RS-232 communications. x=N: Do not.
SDI-12 Setup	TxRealTime=x	x=Y: Output real-time data for RS-232 communications while sampling autonomously. x=N: Do not.
	SetAddress=x	x= address (0-9, a-z, A-Z) for SDI-12 communications.
Pump Setup	SetSDI12Flag=x	x= out-of-range value (-9999999 to +9999999; must include + or - sign) for SDI-12 communications (OutputFormat=3). Default +9999999 . If MicroCAT calculates out of range data for a particular parameter, this value is inserted in data stream for that parameter.
	MinCondFreq=x	x= minimum conductivity frequency (Hz) to enable pump turn-on.
	AdaptivePumpControl= x	x=Y: Run pump before each sample using <i>Adaptive Pump Control</i> ; run pump for [OxNTau * OxTau20 * ft * fp]. Default . x=N: Do not use <i>Adaptive Pump Control</i> ; run pump before each sample for [OxNTau * OxTau20].
	OxNTau=x	x= pump time multiplier. Default 7.0 .
	PumpOn	Turn pump on for testing or to remove sediment.
SBE 63 Optical DO Sensor Setup	PumpOff	Turn pump off, if turned on with PumpOn .
	Send63=command	Command MicroCAT to send command to SBE 63 and receive response (command can be any command recognized by SBE 63).
Memory Setup	Other commands	See SBE 63 manual for command list. Following setup of SBE 63 is required for use with MicroCAT: SetFormat=1 , SetAvg=1 to 16 (recommended value is 2), SetAutoRun=0 .
	InitLogging	Initialize logging to make entire memory available for recording.
Memory Setup	SampleNumber=x	x= sample number for last sample in memory. SampleNumber=0 equivalent to InitLogging .

Note:
 Commands that enable/disable parameter outputs (temperature, conductivity, pressure, oxygen, salinity, sound velocity, specific conductivity, sample number) only apply if **OutputFormat=1, 2, or 3**. Raw output (**OutputFormat=0**) is not affected by enabling / disabling parameter outputs.

CATEGORY	COMMAND	DESCRIPTION
Output Format Setup	OutputFormat=x	x=0: Output raw decimal data. x=1: Output converted decimal data x=2: Output converted decimal data in XML format. x=3: Output converted decimal data in SDI-12 format.
	OutputTemp=x	x=Y: Output temperature. x=N: Do not.
	SetTempUnits=x	x=0: Temperature °C, ITS-90. x=1: Temperature °F, ITS-90.
	OutputCond=x	x=Y: Output conductivity. x=N: Do not.
	SetCondUnits=x	x=0: Conductivity and specific conductivity S/m. x=1: Conductivity and specific conductivity mS/cm. x=2: Conductivity and specific conductivity µS/cm.
	OutputPress=x	x=Y: Output pressure. x=N: Do not.
	SetPressUnits=x	x=0: Pressure decibars. x=1: Pressure psi (gauge).
	OutputOx=x	x=Y: Output oxygen. x=N: Do not.
	SetOxUnits=x	x=0: Oxygen ml/L. x=1: Oxygen mg/L.
	OutputSal=x	x=Y: Calculate and output salinity (psu). x=N: Do not.
	OutputSV=x	x=Y: Calculate and output sound velocity (m/sec). x=N: Do not.
	OutputSC=x	x=Y: Calculate and output specific conductivity. x=N: Do not.
	UseSCDefault=x	<i>Only applicable if OutputSC=y.</i> x=0: Do not use default; use SetSCA=. x=1: Use default value (0.020) for thermal coefficient of conductivity for natural salt ion solutions (specific conductivity calculation).
	SetSCA=x	<i>Only applicable if OutputSC=y and UseSCDefault=0.</i> x= thermal coefficient of conductivity for natural salt ion solutions (specific conductivity calculation).
	TxSampleNum=x	x=Y: Output sample number with each <i>polled</i> sample. x=N: Do not.
Autonomous Sampling (Logging)	SetCoastal=x	x=0: Reset output units to °C, S/m, dbar, and ml/L, and enable output of temperature, conductivity, pressure, and oxygen (disable output of salinity, sound velocity, specific conductivity, and sample number). x=1: Reset output units to °C, µS/cm, psi, and mg/L (typical for coastal applications), and enable output of temperature, pressure, oxygen, and specific conductivity (disable output of conductivity, salinity, sound velocity, and sample number).
	Legacy=x	x=0: Allow all commands documented in this manual. x=1: Reset output units to °C, S/m, dbar, and ml/L, and enable output of temperature, conductivity, pressure, and oxygen (disable sound velocity, specific conductivity, and sample number). Do not allow user to disable temperature, conductivity, pressure, or oxygen, or to change output units. Modify DS response to match older instruments that did not have SDI-12 capability.
	SampleInterval=x	x= interval (sec) between samples (10 - 21600).
	StartNow	Start logging now.
	StartDateTime=mmddyyhhmmss	Delayed logging start: month, day, year, hour, minute, second.
	StartLater	Start logging at delayed logging start time.
	Stop	Stop logging or waiting to start. Press Enter key before entering Stop . Must stop before uploading data.

Note:
 Do not set **SampleInterval=** to less than (pumping time + sampling time + 5 sec).

CATEGORY	COMMAND	DESCRIPTION
Polled Sampling	TS	Do not pump. Take sample, store in buffer, output.
	TSR	Do not pump. Take sample, store in buffer, output in raw decimal format.
	TPS	Run pump, take sample, store in buffer, output.
	TPSH	Run pump, take sample, store in buffer (do not output).
	TPSS	Run pump, take sample, store in buffer and in FLASH memory, output.
	TSN:x	Do not pump. Take x samples and output data.
	TPSN:x	Run pump continuously while taking x samples and outputting.
	T63	Do not pump. Take sample from SBE 63, output oxygen data in format set by SetFormat= in SBE 63.
	SL	Output last sample in buffer.
SLTP	Output last sample in buffer, run pump, take new sample, store in buffer (do not output new sample).	
Data Upload (send Stop before sending upload command)	GetSamples:b,e	Upload scan b to e , format defined by OutputFormat= .
	DDb,e	Upload scan b to e , converted decimal form (OutputFormat=1).
Coefficients (F=floating point number; S=string with no spaces) Dates shown are when calibrations were performed. Calibration coefficients are initially factory-set and should agree with Calibration Certificates shipped with MicroCATs. View all coefficients with GetCC or DC .	TCalDate=S	S =Temperature calibration date.
	TA0=F	F =Temperature A0.
	TA1=F	F =Temperature A1.
	TA2=F	F =Temperature A2.
	TA3=F	F =Temperature A3.
	CCalDate=S	S =Conductivity calibration date.
	CG=F	F =Conductivity G.
	CH=F	F =Conductivity H.
	CI=F	F =Conductivity I.
	CJ=F	F =Conductivity J.
	WBOTC=F	F =Conductivity wbotc.
	CTCor=F	F =Conductivity ctcor.
	CPCor=F	F =Conductivity cpcor.
	PCalDate=S	S =Pressure calibration date.
	PA0=F	F =Pressure A0.
	PA1=F	F =Pressure A1.
	PA2=F	F =Pressure A2.
	PTCA0=F	F =Pressure ptca0
	PTCA1=F	F =Pressure ptca1.
	PTCA2=F	F =Pressure ptca2.
	PTCB0=F	F =Pressure ptcb0.
	PTCB1=F	F =Pressure ptcb1.
	PTCB2=F	F =Pressure ptcb2.
	PTempA0=F	F =Pressure temperature a0.
	PTempA1=F	F =Pressure temperature a1.
	PTempA2=F	F =Pressure temperature a2.
	POffset=F	F =Pressure offset (decibars).
	OxCalDate=S	S = Oxygen calibration date.
	OxTau20=F	F = Oxygen Tau20 (sensor response time).
	OxA0=F	F = Oxygen A0 coefficient.
	OxA1=F	F = Oxygen A1 coefficient.
	OxA2=F	F = Oxygen A2 coefficient.
	OxB0=F	F = Oxygen B0 coefficient.
OxB1=F	F = Oxygen B1 coefficient.	
OxC0=F	F = Oxygen C0 coefficient.	
OxC1=F	F = Oxygen C1 coefficient.	
OxC2=F	F = Oxygen C2 coefficient.	
OxTA0=F	F = Oxygen TA0 coefficient.	
OxTA1=F	F = Oxygen TA1 coefficient.	
OxTA2=F	F = Oxygen TA2 coefficient.	
OxTA3=F	F = Oxygen TA3 coefficient.	
OxE=F	F = Oxygen E coefficient.	

Note:
Use **Seaterm232's** Upload menu to upload data that will be processed by **SBE Data Processing**. Manually entering a data upload command does not produce data with the required header information for processing by **SBE Data Processing**.

Appendix IV: AF24173 Anti-Foulant Device

AF24173 Anti-Foulant Devices supplied for user replacement are supplied in polyethylene bags displaying the following label:

AF24173 ANTI-FOULANT DEVICE	
FOR USE ONLY IN SEA-BIRD ELECTRONICS' CONDUCTIVITY SENSORS TO CONTROL THE GROWTH OF AQUATIC ORGANISMS WITHIN ELECTRONIC CONDUCTIVITY SENSORS.	
ACTIVE INGREDIENT:	
Bis(tributyltin) oxide.....	53.0%
OTHER INGREDIENTS:	<u>47.0%</u>
Total.....	100.0%
DANGER	
See the complete label within the Conductivity Instrument Manual for Additional Precautionary Statements and Information on the Handling, Storage, and Disposal of this Product.	
Net Contents: Two anti-foulant devices	
Sea-Bird Electronics, Inc. 13431 NE 20 th Street Bellevue, WA 98005	EPA Registration No. 74489-1 EPA Establishment No. 74489-WA-1

AF24173 Anti-Foulant Device

FOR USE ONLY IN SEA-BIRD ELECTRONICS' CONDUCTIVITY SENSORS TO CONTROL THE GROWTH OF AQUATIC ORGANISMS WITHIN ELECTRONIC CONDUCTIVITY SENSORS.

ACTIVE INGREDIENT:

Bis(tributyltin) oxide.....	53.0%
OTHER INGREDIENTS:	47.0%
Total.....	100.0%

DANGER

See Precautionary Statements for additional information.

FIRST AID	
If on skin or clothing	<ul style="list-style-type: none"> Take off contaminated clothing. Rinse skin immediately with plenty of water for 15-20 minutes. Call a poison control center or doctor for treatment advice.
If swallowed	<ul style="list-style-type: none"> Call poison control center or doctor immediately for treatment advice. Have person drink several glasses of water. Do not induce vomiting. Do not give anything by mouth to an unconscious person.
If in eyes	<ul style="list-style-type: none"> Hold eye open and rinse slowly and gently with water for 15-20 minutes. Remove contact lenses, if present, after the first 5 minutes, then continue rinsing eye. Call a poison control center or doctor for treatment advice.
HOT LINE NUMBER	
Note to Physician	Probable mucosal damage may contraindicate the use of gastric lavage.
Have the product container or label with you when calling a poison control center or doctor, or going for treatment. For further information call National Pesticide Telecommunications Network (NPTN) at 1-800-858-7378.	

Net Contents: Two anti-foulant devices

Sea-Bird Electronics, Inc.
 13431 NE 20th Street
 Bellevue, WA 98005

EPA Registration No. 74489-1
 EPA Establishment No. 74489-WA-1

PRECAUTIONARY STATEMENTS

HAZARD TO HUMANS AND DOMESTIC ANIMALS

DANGER

Corrosive - Causes irreversible eye damage and skin burns. Harmful if swallowed. Harmful if absorbed through the skin or inhaled. Prolonged or frequently repeated contact may cause allergic reactions in some individuals. Wash thoroughly with soap and water after handling.

PERSONAL PROTECTIVE EQUIPMENT

USER SAFETY RECOMMENDATIONS

Users should:

- Remove clothing immediately if pesticide gets inside. Then wash thoroughly and put on clean clothing.
- Wear protective gloves (rubber or latex), goggles or other eye protection, and clothing to minimize contact.
- Follow manufacturer's instructions for cleaning and maintaining PPE. If no such instructions for washables, use detergent and hot water. Keep and wash PPE separately from other laundry.
- Wash hands with soap and water before eating, drinking, chewing gum, using tobacco or using the toilet.

ENVIRONMENTAL HAZARDS

Do not discharge effluent containing this product into lakes, streams, ponds, estuaries, oceans, or other waters unless in accordance with the requirements of a National Pollutant Discharge Elimination System (NPDES) permit and the permitting authority has been notified in writing prior to discharge. Do not discharge effluent containing this product to sewer systems without previously notifying the local sewage treatment plant authority. For guidance contact your State Water Board or Regional Office of EPA. This material is toxic to fish. Do not contaminate water when cleaning equipment or disposing of equipment washwaters.

PHYSICAL OR CHEMICAL HAZARDS

Do not use or store near heat or open flame. Avoid contact with acids and oxidizers.

DIRECTIONS FOR USE

It is a violation of Federal Law to use this product in a manner inconsistent with its labeling. For use only in Sea-Bird Electronics' conductivity sensors. Read installation instructions in the applicable Conductivity Instrument Manual.

STORAGE AND DISPOSAL

PESTICIDE STORAGE: Store in original container in a cool, dry place. Prevent exposure to heat or flame. Do not store near acids or oxidizers. Keep container tightly closed.

PESTICIDE SPILL PROCEDURE: In case of a spill, absorb spills with absorbent material. Put saturated absorbent material to a labeled container for treatment or disposal.

PESTICIDE DISPOSAL: Pesticide that cannot be used according to label instructions must be disposed of according to Federal or approved State procedures under Subtitle C of the Resource Conservation and Recovery Act.

CONTAINER HANDLING: Nonrefillable container. Do not reuse this container for any other purpose. Offer for recycling, if available.

Appendix V: Replacement Parts

Part Number	Part	Application Description	Quantity in MicroCAT
50441	AA Saft Lithium cell set (12)	Power MicroCAT	1
801863	Cell holder for SBE 37 ODO MicroCATs	Holds AA cells	1
801542	AF24173 Anti-Foulant Device	Bis(tributyltin) oxide device inserted into anti-foulant device cup	1 (set of 2)
30411	Triton X-100	Octyl Phenol Ethoxylate – Reagent grade non-ionic cleaning solution for conductivity cell (supplied in 100% strength; dilute as directed)	1
802220	6-pin MCIL-6FS (wet-pluggable connector) to 9-pin DB-9S I/O cable with power leads and leads to SDI-12, 2.4 m (8 ft) long	From MicroCAT to computer and/or SDI-12 controller	1
171192	Locking sleeve (wet-pluggable connector)	Locks cable/plug in place	1
171498.1	6-pin MCDC-6-F dummy plug with locking sleeve, wet-pluggable connector	For when cable not used	1
171888	25-pin DB-25S to 9-pin DB-9P cable adapter	For use with computer with DB-25 connector	-

<p>60056</p>	<p>Spare hardware / O-ring kit for 37-SMP-ODO</p>	<p>Assorted hardware and O-rings:</p> <ul style="list-style-type: none"> • 30900 Bolt, 1/4-20 x 2", Hex head, titanium (secures guide to connector end cap and clamp to sensor end cap) • 30633 Washer, 1/4" Split Ring Lock, titanium (for 30900) • 30634 Washer, 1/4" Flat, titanium (for 30900) • 31019 O-ring, Parker 2-008 N674-70 (for 30900) • 31066 Cap screw, 8-32 x 3/4 socket head, titanium (secures guide to connector end cap) • 31873 Cap Screw, 6-32 x 1/2", socket head, titanium (secures clamp to sensor end cap) • 30867 Washer, #6 split ring lock, titanium (for 31873) • 31755 Cap Screw, 8-32 x 1/4" SH, titanium (secures connector end cap to housing) • 30857 O-ring, Parker 2-033E515-80 (connector end cap O-rings) • 30858 O-ring, Parker 2-133 N674-70 (battery pack end cap O-ring) • 31322 O-ring, Parker 2-130 N674-70 (battery pack housing O-rings) • 31749 Hex Key, 7/64" long arm, DoALL BDH12106 (tool for battery pack) • 31089 Screw, 10-32 x 1/2" FH Phillips, titanium (secures cell guard to end cap) • 31118 Screw, 10-32 x 3/8" FH Phillips, titanium (secures cell guard to sensor end cap) • 31516 Hex Key, 9/64" long arm, DoALL AHT58010 (tool for guide) • 311281 Removable shipping sticker (covers cell intake and exhaust for storage) • Air bleed valve wire kit (for clearing bleed valve) 	<p>-</p>
--------------	---	---	----------

Appendix VI: Manual Revision History

Manual Version	Date	Description
001	11/12	<ul style="list-style-type: none"> Initial release for Beta testing.
002	12/12	<ul style="list-style-type: none"> First production version release – product and documentation changes.
003	04/13	<ul style="list-style-type: none"> Firmware 2.1.0: Fix <SDI-12Address> and <SDI-12Flag> tags in GetCD response – hyphens are not valid in XML tags. Firmware 2.2.0: <ul style="list-style-type: none"> Delete MicroCAT baud rates less than 4800 baud, which are not compatible with DO sensor. Add Legacy= command for consistency with other MicroCATs of this generation. Add example of how firmware version looks different in a! and aXV! command responses. Update SeatermV2 main screen capture. Update Seaterm232 Serial Port Config dialog screen capture. Fix typos.
004	10/13	<ul style="list-style-type: none"> Firmware 2.4.2: OxNTau= now appears in GetCD and DS responses. GetHD response now provides correct XML formatting. Correct description of OxNTau. OxNTau affects pump time, regardless of whether Adaptive Pump Control is enabled or disabled (documentation previously said that it had no effect if Adaptive Pump Control was enabled). Correct minimum pump time with Adaptive Pump Control to 3.0 sec. Correct quiescent current to 78 μA (was 70). Update plastic housing depth rating to 350 meters. Add more information on required settings in SBE 63. Update SeatermV2 screen capture and Upload dialog box. Add information on editing raw .hex files. Update contents of spare hardware & o-ring kit. Add information on new protective label to cover intake and exhaust, in place of plugs that were used previously. Update information on cleaning air bleed valve. Add information on O-ring maintenance. Clarify that accuracy specifications are \pm. Clarify that SetPressUnits=0 (decibars) and OutputPress=Y in pressure sensor calibration example in Section 5. Update Declaration of Conformity. Fix typos.
005	03/14	<ul style="list-style-type: none"> Update temperature range and accuracy specifications. Update lithium cell and battery language to conform to latest IATA rules. Add caution on using spray can lubricants on MCBH connectors. Remove <i>standard</i> and <i>optional</i> language. Fix typos.

Index

.hex files
editing · 72

A

Adaptive pump control · 14, 44
Air bleed hole · 61, 74
Anti-Foulant Device · 91
removal before shipping to Sea-Bird · 79
replacing · 77, 78
Autonomous sampling · 30, 49

B

Batteries · 11, 62
description · 20
endurance · 16
installing · 20
replacing · 76
shipping precautions · 8
Battery endurance · 10
Baud rate · 31, 42
Bleed hole · 61, 74

C

Cable length · 31
Cables · 13
Calibration · 79
CE certification · 3
Cleaning · 74
Clock · 11, 85
Command summary · 88
Commands
autonomous sampling · 49
baud rate · 42
calibration coefficients · 52
data format · 47
data upload · 51, 65
date and time · 42
descriptions · 32, 53
general setup · 42
logging · 49
memory setup · 46
optical dissolved oxygen sensor setup · 45
polled sampling · 50
pump setup · 44
RS-232 setup · 43
SBE 63 setup · 45
SDI-12 · 53
SDI-12 setup · 43
status · 33
upload · 65
Communication defaults · 25
Conductivity cell · 85
cleaning · 74
Connector · 12, 73
Corrosion precautions · 73

D

Data Conversion · 68
Data format · 47, 56, 57
Data processing · 10, 22, 65, 68
Data upload · 65
Date and time · 42
Declaration of Conformity · 3
Deployment · 61
installation · 63
preparing for · 20
setup · 62
Deployment Endurance Calculator · 10, 16
Deployment orientation · 10, 12, 63
Derive · 68
Description · 9
Dimensions · 12
Dissolved oxygen sensor
cleaning · 74
Dissolved Oxygen sensor · 85

E

Editing data files · 72
Electronics disassembly/reassembly · 86
End cap · 73
End cap connector · 12
External power · *See* Power, external

F

Flooded MicroCAT · 64
Format
data · 56, 57
Functional description · 85

G

Glossary · 83
Guard
removal · 77, 78

I

Initializing memory · 46

L

Limited liability statement · 2
Logging · 30, 49

M

Maintenance · 73
 Manual revision history · 97
 Memory · 11
 Memory setup · 46
 Minimum conductivity frequency · 14, 44
 Modes · *See* Sampling modes
 Mounting · 61

O

Orientation · 61
 Output format · 47, 57
 Oxygen sensor · 85
 cleaning · 74

P

Parker Super O-Lube · 84
 Parts
 replacement · 95
 Plastic housing
 handling · 75
 Plumbing
 maintenance · 74
 Polled sampling · 29
 Power
 endurance · 10
 external · 11, 18
 Pressure sensor · 85
 maintenance · 76
 Processing data · 65
 Pump · 10, 11, 12, 14, 28, 50, 61, 63
 Pump setup commands · 44

Q

Quick start · 6

R

Real-time setup
 baud rate · 31
 cable length · 31
 Recovery · 64
 uploading data · 65
 Replacement parts · 95
 Revision history · 97
 RS-232 output format · 57
 RS-232 setup commands · 43

S

Sample timing · 16
 Sampling modes · 28
 autonomous · 30
 logging · 30
 polled · 29
 SBE Data Processing · 10, 22, 68
 SDI-12
 commands · 53
 data format · 56
 SDI-12 setup commands · 43
 Sea Plot · 68
 Seasoft · 10, 22
 Seaterm232 · 10, 22, 23, 65
 SeatermV2 · 10, 22, 23, 65
 Sensors · 11
 Setup commands · 42
 ShallowCAT
 handling · 75
 Shipping precautions · 8
 Software · 10, 22
 Specifications · 11
 Status commands · 33
 Storage · 74
 Super O-Lube · 84
 System description · 9

T

Terminal program · 10, 22, 23, 65
 Testing · 22
 Thermistor · 85
 Timeout description · 31
 Transient current · 18
 Triton · 84
 Troubleshooting · 81

U

Unpacking MicroCAT · 7
 Uploading data · 65

V

Versions · 97

W

Wiring · 13, 22