

SBE 44

Underwater Inductive Modem (UIM)

With RS-232 Interface for Serial Instrument



User's Manual

Sea-Bird Electronics, Inc.
13431 NE 20th Street
Bellevue, Washington 98005 USA
Telephone: +1 425-643-9866
Fax: +1 425-643-9954
seabird@seabird.com
www.seabird.com

Manual Version #022, 03/12/14
SBE 44 Firmware Version 1.9a & later
SIM Firmware Version 3.0a & later
IMM firmware 1.12 & later



Limited Liability Statement

Extreme care should be exercised when using or servicing this equipment. It should be used or serviced only by personnel with knowledge of and training in the use and maintenance of oceanographic electronic equipment.

SEA-BIRD ELECTRONICS, INC. disclaims all product liability risks arising from the use or servicing of this system. SEA-BIRD ELECTRONICS, INC. has no way of controlling the use of this equipment or of choosing the personnel to operate it, and therefore cannot take steps to comply with laws pertaining to product liability, including laws which impose a duty to warn the user of any dangers involved in operating this equipment. Therefore, acceptance of this system by the customer shall be conclusively deemed to include a covenant by the customer to defend, indemnify, and hold SEA-BIRD ELECTRONICS, INC. harmless from all product liability claims arising from the use or servicing of this system.

Declaration of Conformity

Sea-Bird Electronics, Inc.
13431 NE 20th Street, Bellevue, WA 98005 USA

DECLARATION OF CONFORMITY

Manufacturer's Name: Sea-Bird Electronics
Manufacturer's Address: 13431 NE 20th Street
Bellevue, WA 98005, USA

The Authorized Representative located within the Community is:
OTT MESSTECHNIK GmbH & Co.KG
P.O.Box: 2140 / 87411 Kempten / Germany
Ludwigstrasse 16 / 87437 Kempten
Internet: <http://www.ott.com>
Phone: +49 831 5617 – 100
Fax: +49 831 5617 - 209

Device Description: Various Data Acquisition Devices and Sensors

Model Numbers:

3S	3F	3plus	4C	4M	5T	5P	5M	7
8	9plus	11plus	14	16plus V2	16plus-IM V2		17plus V2	18
19plus V2	21	25plus	26plus	27	29	32	32C	32SC
33	35	35RT	36	37-IMP	37-IM	37-SMP	37-SM	37-SIP
37-SI	38	39	39-IM	39plus	41	41CP	43	43F
44	45	49	50	52-MP	53BPR	54	55	56
63	SIM	ICC	IMM	PDIM	AFM	90488	90204	90402
90504	Glider Payload CTD		NiMH Battery Charger and Battery Pack					

Applicable EU Directives: Machinery Directive 98 / 37 /EC
EMC Directive 2004 / 108 /EC
Low Voltage Directive (73 / 23 /EEC) as amended by (93 / 68 /EEC)

Applicable Harmonized Standards:
EN 61326-1:2006 Class A Electrical Equipment for Measurement, Control, and Laboratory Use, EMC Requirement – Part 1: General Requirements
(EN 55011:2007 Group 1, Class A)

EN 61010-1:2001, Safety Requirements for Electrical Equipments for Measurement, Control, and Laboratory Use – Part 1: General Requirements

Declaration based upon compliance to the Essential Requirements and Letter of Opinion from CKC Certification Services, LLC., Notified Body 0976

I, the undersigned, hereby declare that the equipment specified above conforms to the above European Union Directives and Standards.

Authorized Signature: 
Name: Nordeen Larson
Title of Signatory: President
Date: 3 September 2013
Place: Bellevue, WA

Table of Contents

Limited Liability Statement	2
Declaration of Conformity	3
Table of Contents	4
Section 1: Introduction	6
About this Manual	6
Quick Start	6
Unpacking SBE 44.....	7
Shipping Precautions	8
Section 2: Description of SBE 44	9
System Description	9
Specifications	10
Dimensions and Bulkhead Connector.....	11
External Power (optional).....	12
Battery Pack Endurance	12
Surface Inductive Modem (SIM) or Inductive Modem Module (IMM)	13
Mooring Cable and Wiring Requirements	14
Section 3: Preparing SBE 44 for Deployment	15
Battery Pack Installation	15
Description of Cells and Battery Pack	15
Installing Cells and Battery Pack	15
Software Installation	17
Power and Communications Test and Setting SBE 44 IDs – Using Surface Inductive Modem (SIM).....	18
Test Setup with SIM	18
Test and Set SBE 44 ID Using SBE 44 with SIM	19
Power and Communications Test and Setting SBE 44 IDs – Using Inductive Modem Module (IMM)	23
Test Setup with IMM	23
Setup of IMM for use with SBE 44	24
Test and Set SBE 44 ID Using SBE 44 with IMM	25
Section 4: Deploying and Operating SBE 44	29
Operation Description	29
Operating Modes	31
Examples	33
Timeout Descriptions.....	36
IMM Timeouts.....	36
SIM Timeouts	36
SBE 44 Timeouts.....	36
Command Descriptions.....	37
SIM Commands	37
ID Commands	39
SBE 44 and Sensor Commands	39
Setup for Deployment	46
SBE 44 Deployment	47
System Installation and Wiring	48
Installing Optional Inductive Cable Coupler (ICC)	48
Recovery	49
Section 5: Routine Maintenance	50
Corrosion Precautions.....	50
Replacing AA cells	50
Connector Mating and Maintenance	50
O-Ring Maintenance.....	51

Section 6: Troubleshooting	52
Problem 1: Unable to Communicate with SBE 44.....	52
Glossary	53
Appendix I: Functional Description	54
Appendix II: Electronics Disassembly/Reassembly	55
Appendix III: Command Summary	56
Appendix IV: SIM Hookup and Configuration	61
Power Connection.....	61
Interface Option Connection (J1, J2, and J4) and	
I/O Connector Wiring (JP2).....	62
Notes on RS-485 Interface.....	62
Inductive Mooring Cable Connection (JP4)	62
Normal Deployed Operation (J5).....	62
Tone Detect Board Connection.....	63
Appendix V: SBE 44 Interface PCB Configuration	64
Standard Setup (no optional control signal or optional switched power out) ..	64
Optional Control Signal (jumper J1 on Interface PCB)	64
Optional Switched Power Out (jumper J2 on Interface PCB).....	64
Appendix VI: Using SBE 44 with Tone Detect Board	65
Wiring	65
Operation	66
Appendix VII: Character Map and Values	69
Appendix VIII: Replacement Parts	70
Appendix IX: Manual Revision History	71
Index	73

Section 1: Introduction

This section includes contact information, Quick Start procedure, photos of a typical SBE 44 Underwater Inductive Modem (UIM) shipment, and shipping precautions.

About this Manual

This manual is to be used with the SBE 44 UIM.

It is organized to guide the user from installation through operation. We've included detailed specifications, command descriptions, maintenance information, and helpful notes throughout the manual.

Sea-Bird welcomes suggestions for new features and enhancements of our products and/or documentation. Please contact us with any comments or suggestions (seabird@seabird.com or 425-643-9866). Our business hours are Monday through Friday, 0800 to 1700 Pacific Standard Time (1600 to 0100 Universal Time) in winter and 0800 to 1700 Pacific Daylight Time (1500 to 0000 Universal Time) the rest of the year.

Quick Start

Follow these steps to get a Quick Start using the SBE 44.
The manual provides step-by-step details for performing each task:

1. Perform pre-check (*Section 3: Preparing SBE 44 for Deployment*):
 - A. Install lithium AA cells.
 - B. Test power and communications, and set SBE 44 ID.
2. Deploy SBE 44 (*Section 4: Deploying and Operating SBE 44*):
 - A. Install new lithium AA cells if necessary.
 - B. Input system operating parameters.
 - C. Check status (**!iIDS**) to verify setup.
 - D. Deploying multiple SBE 44s: verify Seaterm set to *Prompt ID*.
 - E. Install cable connecting SBE 44 to serial instrument.
 - F. Install SBE 44 on mooring cable.
 - G. (optional) Install Inductive Cable Coupler on mooring cable.
 - H. Wire system.

Unpacking SBE 44

Shown below is a typical SBE 44 shipment.



SBE 44

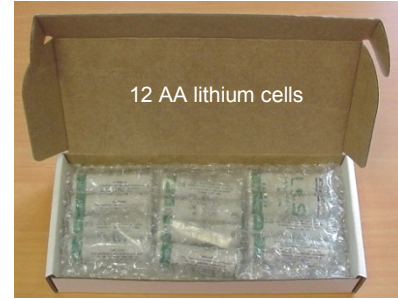

12 AA lithium cells



Spare parts (hardware and o-rings) kit



Software, and Electronic Copies of Software Manuals and User Manual



Serial Test Cable – connects SBE 44 to computer to test serial communications through SBE 44's RS-232 bulkhead connector

Note:
SBE 44 can be used with SIM or with IMM; IMM not shown.

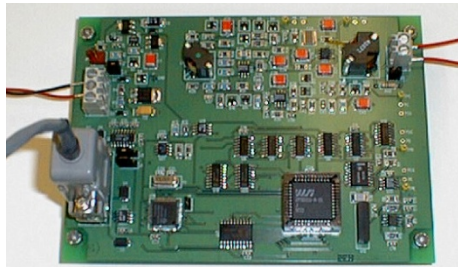

Surface Inductive Modem (SIM) PCB (one per mooring, optional)



I/O Cable (included with SIM)

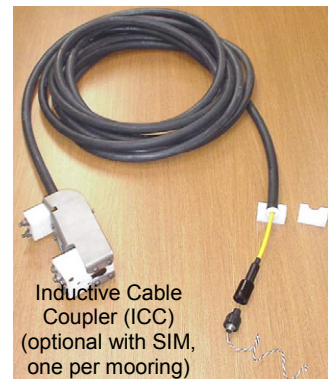

Inductive Cable Coupler (ICC) (optional with SIM, one per mooring)

Shipping Precautions

DISCLAIMER / WARNING:

The shipping information provided in is a general overview of lithium shipping requirements; it does not provide complete shipping information. The information is provided as a courtesy, to be used as a guideline to assist properly trained shippers. These materials do not alter, satisfy, or influence any federal or state requirements. These materials are subject to change due to changes in government regulations. Sea-Bird accepts no liability for loss or damage resulting from changes, errors, omissions, or misinterpretations of these materials. **See the current edition of the IATA Dangerous Good Regulations for complete information on packaging, labeling, and shipping document requirements.**



WARNING!
Do not ship assembled battery pack.

Assembled battery pack

For its main power supply, the SBE 44 uses twelve 3.6-volt AA lithium cells (Saft LS14500). The SBE 44 was shipped from the factory with the cells packaged separately within the shipping box (not inside SBE 44).

BATTERY PACKAGING

Cells are packed in heat-sealed plastic, and then placed in bubble-wrap outer sleeve and strong packaging for shipment.



If the shipment is not packaged as described above, or does not meet the requirements below, the shipment is considered Dangerous/Hazardous Goods, and must be shipped according to those rules.

	1-5 SBE 44s and associated cells, but no spares	1-5 SBE 44s and associated cells, plus up to 2 spare cell sets/SBE 44	Spares (without SBE 44s) – Note new rules as of January 1, 2013
UN #	UN3091	UN3091	Must be shipped as Class 9 Dangerous Goods . If re-shipping spares, you must have your own Dangerous Goods program.
Packing Instruction (PI) #	969	969	
Passenger Aircraft	Yes	No	
Cargo Aircraft	Yes	Yes	
Labeling Requirement	1 **	1, 2 **	
Airway Bill (AWB) Requirement	Yes *	Yes *	

* AWB must contain following information in Nature and Quantity of Goods Box: "Lithium Metal Batteries", "Not Restricted", "PI #"
 ** Labels are defined below:



2

1 – Shipper must provide an emergency phone number

Note:

Remove the cells before returning the SBE 44 to Sea-Bird. Do not return used cells when shipping the SBE 44 for repair. All setup information is preserved when the cells are removed.

Install battery pack assembly in the SBE 44 for testing (see *Battery Pack Installation* in Section 3). **If you will re-ship the SBE 44 after testing:**

1. Remove the battery pack assembly from the SBE 44.
2. Remove the cells from the battery pack assembly.
3. Pack the cells properly for shipment, apply appropriate labels, and prepare appropriate shipping documentation.

Section 2: Description of SBE 44

This section describes the functions and features of the SBE 44, including specifications, dimensions, and mooring requirements.

System Description



Note:

For detailed information on inductive modem systems, see *Real-Time Oceanography with Inductive Moorings*, at www.seabird.com under *Technical Papers*.

Note:

Half-duplex communication is **one-direction** at a time (i.e., you cannot send commands and receive data at the same time). For example, if the IMM or SIM commands an SBE 44 to upload data from the serial instrument, nothing else can be done while the data is being sent – the data upload cannot be stopped, and commands cannot be sent to other SBE 44s on the line.

The SBE 44 Underwater Inductive Modem (UIM) makes it possible to integrate current meters, Doppler profilers, or other instruments having standard serial interfaces with MicroCATs or other instruments that communicate via Sea-Bird's inductive modem telemetry system. The SBE 44 has a built-in inductive cable coupler (split toroid) and cable clamp, providing data communications without the need for electrical connections, and an easy and secure attachment to any point on a jacketed mooring wire. An underwater bulkhead connector on the end cap provides the serial data connection, an optional control line, and optional switched power out. Designed for moorings and other long duration, fixed-site deployments, SBE 44s have non-corroding titanium housings rated for operation to 7000 meters (23,000 feet).

When using the SBE 44, all that is required to link a computer or data logger to a serial instrument is an Inductive Modem Module (IMM) or Surface Inductive Modem (SIM), and a jacketed mooring wire. Communication between the PC or data logger and the IMM/SIM is full-duplex RS-232C (optional RS-485 for SIM). Commands and data are transmitted half-duplex between the IMM/SIM and the SBE 44. The SBE 44 interprets the commands, relays correctly addressed commands to the serial instrument, and transmits replies from the instrument to the IMM/SIM.

The SBE 44 transmits data over any insulated wire. Communication on a mooring is typically via the jacketed mooring wire. Cables up to 7000 meters (23,000 feet) long can be used. The superiority of the DPSK telemetry system provides a high degree of immunity from *fishbite* or other cable degradation. Laboratory bench testing may be performed by simply looping any insulated wire through the inductive core and connecting the ends of the wire to the IMM/SIM.

Each SBE 44 has a unique programmable address (ID), allowing up to 100 SBE 44s (or other instruments compatible with the Sea-Bird inductive modem) to be attached to a single mooring cable. Upon power up or receipt of the global wakeup command, the SIM sends a tone for two seconds, waking all SBE 44s on the cable. When the SBE 44 receives a command containing its unique ID, it relays the command to the serial instrument and then transmits the reply over the inductive link. A 30 Kbyte FIFO buffer allows the SBE 44 to interface to a serial instrument at 300, 600, 1200, 2400, 4800, 9600, or 19200 baud while transmitting data at 1200 baud over the inductive modem link. Programmable setup parameters stored in EEPROM include timeout values, control signal logic, and sensor response termination logic, allowing the SBE 44 to interface to a wide variety of instruments without requiring custom programming. A global power-off command returns all SBE 44s to a quiescent (sleep) stand-by state. The SBE 44 automatically returns to quiescent state if there is no line activity for a user-specified length of time.

Note:

Characters sent **from** the serial instrument **to** the SBE 44 must be greater than 09 decimal (09 Hex) and less than 123 decimal (7B Hex). Additionally, the @ symbol (64 decimal or 40 Hex) cannot be sent.

Data can be requested and transmitted from the serial instrument in several ways, including:

- **Relay command** – sends a user-defined command string, character, or break recognizable by the serial instrument. This command is sent to a specific SBE 44, which transmits the character string / break to the serial instrument. The serial instrument replies to the SBE 44, which immediately transmits the reply to the SIM and computer/controller. Use a Relay command when you want data from a particular serial instrument, and do not want to synchronize with data from other serial instruments.
- **Get Data command** – sends a user-defined character string recognizable by the serial instrument. Get Data can be global (sent to all SBE 44s on the cable) or local (sent to a specific SBE 44). The SBE 44 transmits the character string to the serial instrument. The serial instrument replies to the SBE 44, which holds the reply in a buffer. Another command gets the reply from a specific SBE 44 and transmits it to the IMM/SIM and computer/controller. Use the global Get Data command when you want synchronized data from each SBE 44 (and attached serial instrument) on the cable.

The SBE 44's internal battery pack uses twelve AA lithium cells. The SBE 44 can be externally powered, and can provide power to the serial instrument from either the external source or its internal battery pack, via the switched power output pin on the bulkhead connector.

Note:

Help files provide detailed information on Seaterm.

The SBE 44 is supplied with a powerful Windows software package, Seasoft V2, which includes:

- **Seaterm** - terminal program for easy communication with the SBE 44 (via the IMM or SIM) and data retrieval.

Specifications

Internal Battery Pack	Nominal 10.6 Amp-hour pack consisting of 12 AA Saft LS 14500 lithium cells (3.6 V, 2.45 Amp-hours each); derated to 8.8 Amp-hours (if not supplying power to serial instrument) or 5.7 Amp-hours (if supplying power to serial instrument). See <i>Battery Endurance</i> for example calculation. Also see <i>Shipping Precautions</i> in <i>Section 1: Introduction</i> . Note: Saft cells (www.saftbatteries.com) can be purchased from Sea-Bird or other sources. Alternatively, substitute: - Tadiran TL-4903, AA (3.6 V, 2.4 Amp-hours each) (www.tadiran.com), or - Electrochem 3B0064/BCX85, AA (3.9 V, 2.0 Amp-hours each) (www.electrochemsolutions.com)
Current	Quiescent Current: < 100 microAmps Operating Current: 10 milliAmps Maximum Current to serial instrument: 1.5 Amps (see <i>Battery Pack Endurance</i> for length of deployment)
Materials	Titanium pressure case rated at 7000 meters (23,000 feet)
Serial Instrument Interface	RS-232 standard
Weight	<i>In water:</i> 2.1 kg (4.7 lbs) <i>In air:</i> 3.2 kg (7.1 lbs)

Dimensions and Bulkhead Connector

Dimensions in millimeters (inches).

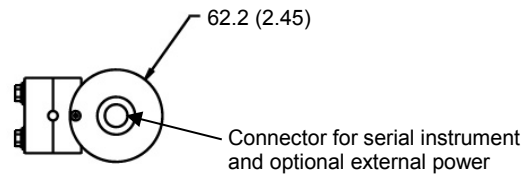
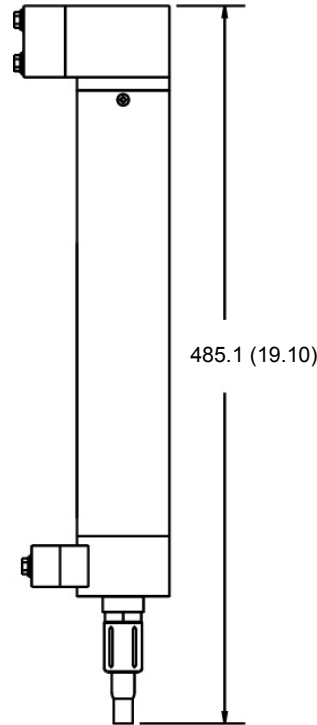
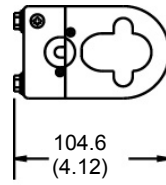

Note:
See *Appendix V: SBE 44 Interface PCB Configuration* for required jumper settings for switched power out and control signal.

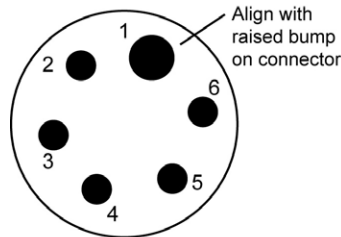

AG-306-HP

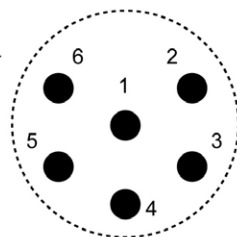

**Wet-Pluggable
MCBH-6MP (WB), TI**
(3/8" length base, 1/2-20 thread)

Pin	Description
1	Common
2	RS-232C Receive from serial instrument
3	RS-232C Transmit to serial instrument
4	Switched power out (optional)
5	Control signal (optional)
6	External power in (10-20 VDC) (optional)

External Power (optional)

The SBE 44 can be powered from an external source through pin 6 on the bulkhead connector. The internal battery pack is diode-OR'd with the external source, so **power for the SBE 44** is drawn from whichever voltage source is higher. The SBE 44 can also be operated from the external supply without having the lithium batteries installed.

Power for the serial instrument (if connecting to pin 4, switched power out, on the bulkhead connector) is drawn from the SBE 44's battery pack or from the external power source, depending on the J2 jumper setting on the SBE 44 Interface PCB (see *Appendix V: SBE 44 Interface PCB Configuration*).

Battery Pack Endurance

The battery pack has a nominal capacity of 10.6 Amp-hours. This is lower than the Saft factory capacity rating (2.45 Amp-hours * 6 = 14.7 Amp-hours), because the cell holder includes voltage up-conversion circuitry that consumes some capacity. For planning purposes, to account for the SBE 44's current consumption patterns and for environmental conditions affecting cell performance, **Sea-Bird recommends using a conservative value:**

- SBE 44 **not** providing power to serial instrument - 8.8 Amp-hours
- SBE 44 **providing power** to serial instrument - 5.7 Amp-hours

Note:

Sea-Bird recommends using these recommended capacity values for Saft cells as well as for the alternate cells (Tadiran TL-4903 and Electrochem 3B0064/BCX85 AA).

Current consumption is as follows:

- SBE 44's 10 mA operating current is drawn during each of these stages:
 1. Sampling - While the serial instrument is sampling, including any delays programmed into the system.
 2. Communication - While the SBE 44 is transmitting data from its buffer to the IMM/SIM. Assuming the fastest practical interrogation scheme (wake all SBE 44s on mooring, send **GData**, send **Dataii** to each SBE 44, and power off all SBE 44s), the operating current is drawn for approximately 0.5 sec **per SBE 44 on the mooring**. Each SBE 44 draws this current while any of the SBE 44s are being queried to transmit data. Other interrogation schemes require more time.
- Optional power for the serial instrument (if connecting serial instrument to pin 4, switched power out, on the bulkhead connector, and J2 on the SBE 44 Interface PCB is set to pins 1 and 2) can be up to 1.5 Amps.
- Quiescent current is less than 100 microAmps (0.9 AH per year).

So, battery pack endurance is highly dependent on the user-programmed sampling scheme. An example is shown below for one sampling scheme.

Example:

10 SBE 44s are deployed on a mooring, and each is powering a serial instrument that draws 50 mA for 3 sec every time it samples. Every 10 minutes, simultaneous data is requested using **GData**, and then data is transmitted sequentially from each SBE 44 using **Dataii**. How long can the instruments be deployed?

Power to serial instrument = 50 mA * 3 sec sampling time = 0.150 Amp-sec/sample

SBE 44 operating current while powering serial instrument = 10 mA * 3 sec sampling time = 0.030 Amp-sec/sample

In 1 hour, sampling consumption = 6 samples * (0.150 + 0.030 Amp-sec/sample) = **1.08 Amp-sec/hour**

Communication current = 10 mA * 0.5 sec/SBE 44 to be queried * 10 SBE 44s on mooring = 0.05 Amp-sec/query

In 1 hour, communication current = 6 queries * 0.05 Amp-sec/query = **0.30 Amp-sec/hour**

Quiescent current = 100 microAmps = 0.1 mA

In 1 hour, quiescent current consumption ≈ 0.1 mA * 3600 sec/hour = **0.36 Amp-sec/hour**

In 1 hour, the current consumption is:

Total current consumption / hour = 1.08 + 0.30 + 0.36 = **1.74 Amp-sec**

Capacity = (5.7 Amp-hours * 3600 sec/hr) / (1.74 Amp-sec/hour) = 11,800 hours = 490 days = 1.3 years

Surface Inductive Modem (SIM) or Inductive Modem Module (IMM)

A Surface Inductive Modem or Inductive Modem Module is required for communication with the SBE 44. These devices impress (*modulate*) the mooring cable with a DPSK signal that is encoded with commands received from the computer/controller. The encoded signals are *demodulated* by SBE 44s coupled to the mooring cable. Replies from SBE 44s are similarly coupled to the mooring cable and *demodulated* by the devices.

Surface Inductive Modem (SIM)

The SIM must be supplied with 7 to 25 volts DC power. The SIM's operating current is approximately 30 milliAmps.

The user's computer or buoy controller can be interfaced via RS-232 (optional RS-485) serial port to the SIM. The standard interface protocol between the user's computer/controller and SIM is 1200, 2400, 4800, or 9600 baud (user-selectable); 8 data bits; no parity; RS-232C; with echoing of characters.

The DPSK communication link between the SIM and IM instruments is half-duplex, so talking and listening is sequential only (cannot send and receive at the same time). Although the data link between the SIM and computer/controller is established at 1200, 2400, 4800, or 9600 baud, the DPSK modem communication between SIM and IM instruments always operates at 1200 baud. Communication between the SBE 44 and serial instrument is user-selectable at 300, 600, 1200, 2400, 4800, 9600, or 19200 baud.

Inductive Modem Module (IMM)

The IMM must be supplied with 7 to 24 volts DC power. The maximum operating current is approximately 15 milliAmps. When using the SBE 44 with the IMM, a minimum of 20 ohms impedance is required.

The user's computer or buoy controller is interfaced via RS-232 serial port to the IMM. The standard interface protocol between the computer/controller and IMM is 1200, 2400, 4800, 9600, or 19200 baud (user-selectable); 8 data bits; no parity; RS-232C.

The DPSK communication link between the IMM and IM instrument(s) is half-duplex, so talking and listening is sequential only (cannot send and receive at the same time). Although the data link between the IMM and the user's computer/controller is established at 1200, 2400, 4800, 9600, or 19200, the DPSK modem communication between IMM and IM instruments always operates at 1200 baud.

See the IMM Manual for details.

Mooring Cable and Wiring Requirements

Notes:

- For wiring, see applicable document:
 - *Appendix IV: SIM Hookup and Configuration.* **OR**
 - IMM manual.
- See *Appendix VI: Using SBE 44 with Tone Detect Board* for a schematic of that specialized application.

The SBE 44 can mechanically accommodate mooring cables up to 16 mm (0.63 inches) in diameter. Clamps for specific cable diameters are available, or can be supplied on a custom basis. Suitable mooring cables use steel wire rope with a polypropylene or polyethylene insulating jacket. The SIM operates without data errors using up to 7000 meters (23,000 feet) of 3 mm (0.12 inches) or larger cable.

The mooring cable must provide connection to seawater ground below the deepest IM instrument. Terminating the wire with a metallic eye or clevis readily provides this connection.

The mooring cable must also provide for connection to the IMM or SIM:

- In a direct connection (typical cable-to-shore applications), the bottom end of the wire is grounded to seawater, and the top end remains insulated to the connection to the IMM/SIM. A second wire from the IMM/SIM connects to seawater ground, completing the circuit.
- In typical surface buoys it is often preferable to connect the jacketed mooring wire to the buoy with a length of chain, grounding the jacketed wire to seawater at each end. An Inductive Cable Coupler (ICC) connects the IMM/SIM to the jacketed wire above the uppermost IM instrument and below the point where the wire is grounded.

IMM with external transformer or SIM-Direct PCB

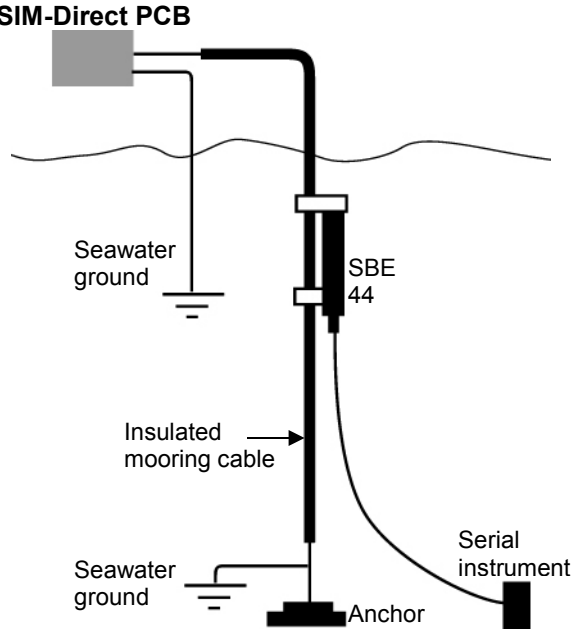

Direct Connection

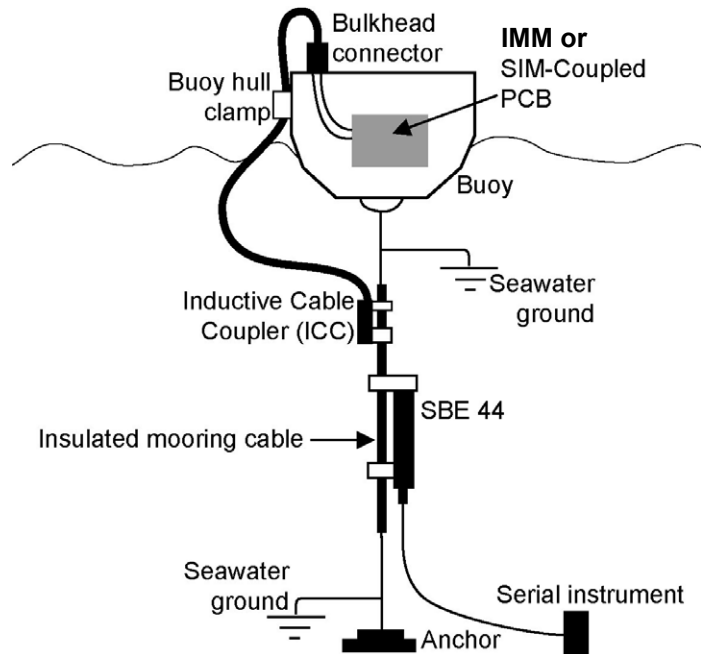

Connection with ICC

Note:

These illustrations are schematic only. The serial instrument, shown on the ocean floor, is usually clamped to the insulated mooring cable at the desired depth.

Section 3: Preparing SBE 44 for Deployment

This section describes installation of the battery pack, installation of software, testing power and communications, and setting the SBE 44 ID.

Battery Pack Installation

WARNING!
Do not ship the SBE 44 with battery pack installed.
See *Shipping Precautions* in *Section 1: Introduction*.

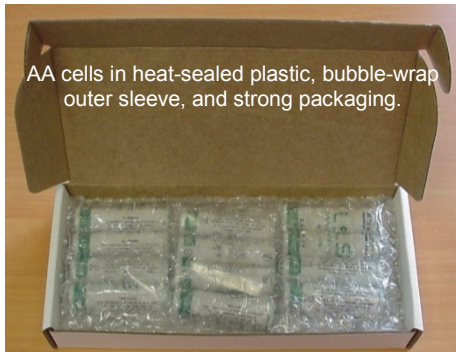

Description of Cells and Battery Pack

Sea-Bird supplies twelve 3.6-volt AA lithium cells, shipped with the SBE 44 in a heat-sealed plastic bag placed in bubble wrap and a cardboard box. The empty cell holder is installed inside the SBE 44 for shipment.

No soldering is required when assembling the battery pack.

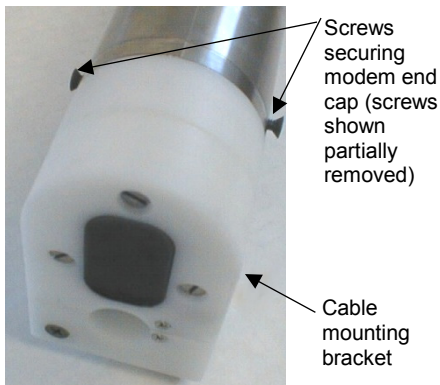

Installing Cells and Battery Pack

1. Remove the modem end cap:
 - A. Wipe the outside of the modem end cap and housing dry, being careful to remove any water at the seam between them.
 - B. Remove the 2 flat Phillips-head titanium machine screws. Do not remove any other screws from the housing.
 - C. Remove the end cap by pulling firmly and steadily on the plastic cable mounting bracket/inductive coupler. It may be necessary to twist or rock the end cap back and forth or use a non-marring tool on the edge of the cap to loosen it.
 - D. The end cap is electrically connected to the electronics with a 3-pin Molex connector. Holding the wire cluster near the connector, pull gently to detach the female end of the connector from the pins.
 - E. Remove any water from the O-ring mating surfaces inside the housing with a lint-free cloth or tissue.
 - F. Put the end cap aside, being careful to protect the O-rings from damage or contamination.

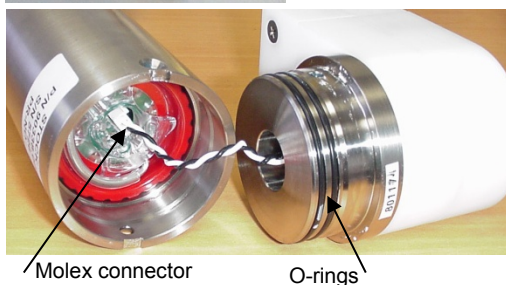

2. Remove the battery pack assembly from the housing:
 - A. Loosen the captured screw from the battery cover plate, using the 7/64-inch Allen wrench included with the shipment.
 - B. Lift the battery pack assembly straight out of the housing, using the handle.

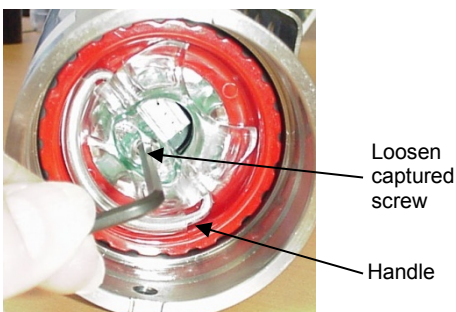

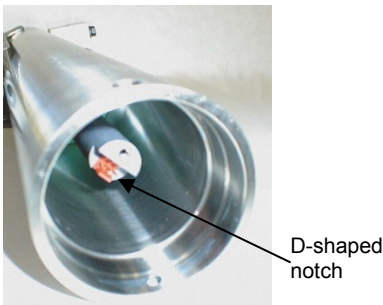
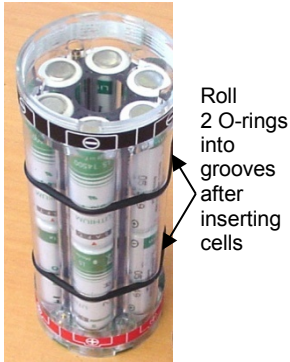
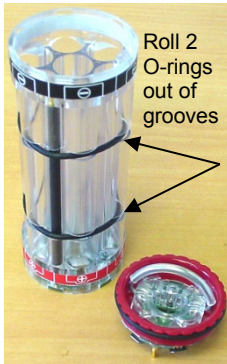

3. Keep the handle in an upright position. Holding the edge of the **red** cover plate, unscrew the cover plate from the battery pack assembly.
Note: Some MicroCATs use a battery pack with a yellow cover plate; the wiring of that pack is different from this one, and **cannot be used with the SBE 44**.
4. Roll the 2 O-rings on the outside of the battery pack out of their grooves.
5. Insert each cell into the pack, **positive end (+) first**.
6. Roll the 2 O-rings on the outside of the battery pack into place in the grooves. The O-rings compress the side of the battery pack and hold the cells tightly in place in the pack.
7. Reinstall the battery pack cover plate:
 - A. Align the pin on the battery cover plate PCB with the post hole in the battery pack housing.
 - B. Place the handle in an upright position. Screw the red cover plate onto the battery pack assembly. Ensure the cover is tightly screwed on to provide a reliable electrical contact.

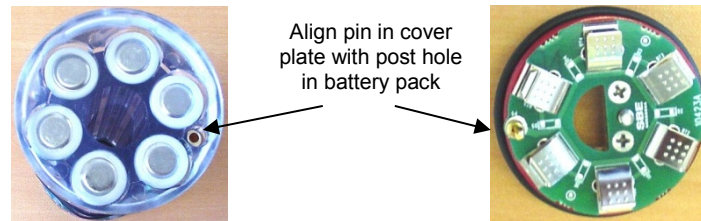

8. Replace the battery pack assembly in the housing:
 - A. Align the D-shaped opening in the cover plate with the D-shaped notch on the shaft. Lower the assembly slowly into the housing, and once aligned, push gently to mate the banana plugs on the battery compartment bulkhead with the lower PCB. A post at the bottom of the battery compartment mates with a hole in the battery pack's lower PCB to prevent improper alignment.
 - B. Secure the assembly to the shaft with the captured screw, using the 7/64-inch Allen wrench. Ensure the screw is tight to provide a reliable electrical contact.
9. Reinstall the modem end cap:
 - A. Remove any water from the O-rings and mating surfaces in the housing with a lint-free cloth or tissue. Inspect the O-rings and mating surfaces for dirt, nicks, and cuts. Clean as necessary. Apply a light coat of O-ring lubricant (Parker Super O Lube) to the O-rings and mating surfaces.
 - B. Plug the female end of the 3-pin Molex connector onto the pins, with the flat portion of the female end against the flat portion of the 'D' cutout. Verify the connector is properly aligned – a backward connection will prevent communication with the computer.
 - C. Carefully fit the end cap into the housing until the O-rings are fully seated.
 - D. Reinstall the 2 flat Phillips-head titanium screws to secure the end cap.

Software Installation

Notes:

- Help files provide detailed information on the software.
- It is possible to use the SBE 44 without the Seaterm terminal program by sending direct commands from a dumb terminal or terminal emulator, such as Windows HyperTerminal.
- Sea-Bird supplies the current version of our software when you purchase an instrument. As software revisions occur, we post the revised software on our FTP site. See our website (www.seabird.com) for the latest software version number, a description of the software changes, and instructions for downloading the software from the FTP site.

Seasoft V2 was designed to work with a PC running Windows XP service pack 2 or later, Windows Vista, or Windows 7.

If not already installed, install Seaterm and other Sea-Bird software programs on your computer using the supplied software CD:

1. Insert the CD in your CD drive.
2. Install software: Double click on **SeasoftV2.exe**. Follow the dialog box directions to install the software. The installation program allows you to install the desired components. Install all the components, or just install Seaterm (terminal program).

The default location for the software is c:\Program Files\Sea-Bird. Within that folder is a sub-directory for each program.

Power and Communications Test and Setting SBE 44 IDs – Using Surface Inductive Modem (SIM)

Note:

You can also simulate the serial instrument using only one computer, if the computer has a spare COM port. Test instructions below are written assuming you are using a second computer.

Note:

For testing and setup, an ICC is not required, even if using SIM-Coupled.

Notes:

- **If more than one IM instrument is on-line when you set the ID, all IM instruments will be set to the same ID.** The inductive modem receivers in IM instruments are very sensitive; two IM instruments that are side-by-side will take the same ID, even if one of them is not on the IM loop. **Therefore, separate IM instruments by at least 2 meters when setting IDs.**
- **Important! For Normal Deployed operation, reinstall the jumper across J5.**

The power and communications test will verify that the system works, prior to deployment. It requires a computer (*Computer #1*) to send commands to the SIM, and connection of the SBE 44's bulkhead connector to one of the following:

- to the serial instrument you intend to use when deployed, **or**
- to a second computer to simulate the serial instrument (*Computer #2*) – an optional serial instrument test cable can be supplied by Sea-Bird.

Test Setup with SIM

1. Loop insulated wire through the SBE 44's modem coupling core to simulate a mooring cable. Connect the test wire ends to the SIM's mooring cable terminals (JP4) (see *Appendix IV: SIM Hookup and Configuration*).
2. On the SIM, remove the J5 jumper (see *Appendix IV*). This inserts a 1K resistor in series with the inductive loop and reduces signal amplitude, preventing SBE 44s that are near, but not attached to, the inductive loop from responding to commands (especially important when sending ***ID=** command).
3. Connect the SIM to a 7-25 VDC power supply. Approximately 30 milliAmps are required. **Do not turn on the power supply yet.**
4. Connect the SIM to Computer #1's serial port using the 9-pin to 9-pin cable supplied with the SIM.
5. If a dummy plug and locking sleeve is installed on the connector: By hand, unscrew the locking sleeve from the SBE 44's bulkhead connector. **If you must use a wrench or pliers, be careful not to loosen the bulkhead connector instead of the locking sleeve.** Remove the dummy plug from the SBE 44's bulkhead connector by pulling the plug firmly away from the connector.
6. Install the serial instrument cable or the test cable: **AG Connector** - align the raised bump on the side of the connector with the large pin (pin 1 - ground) on the SBE 44. **OR** **MCBH Connector** – align the pins with the pins on the SBE 44.
7. Connect the other end of the serial instrument cable or test cable to the desired instrument or to Computer #2.

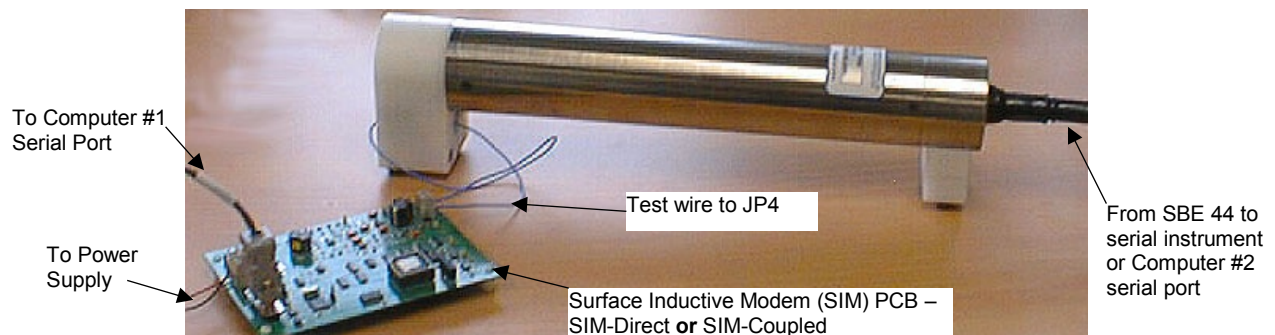
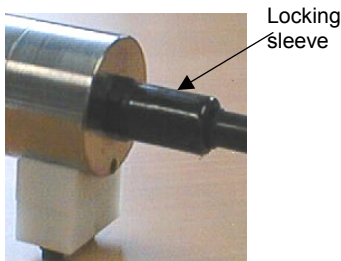

Test and Set SBE 44 ID Using SBE 44 with SIM

Note:
See Seaterm's Help files for detailed information on the use of the program.

1. **On Computer #1** - Double click on Seaterm.exe. If this is the first time the program is used, the setup dialog box may appear:



Select the instrument type (SBE 44) and the computer COM port for communication with the SBE 44. Click OK.

2. The main screen looks like this:

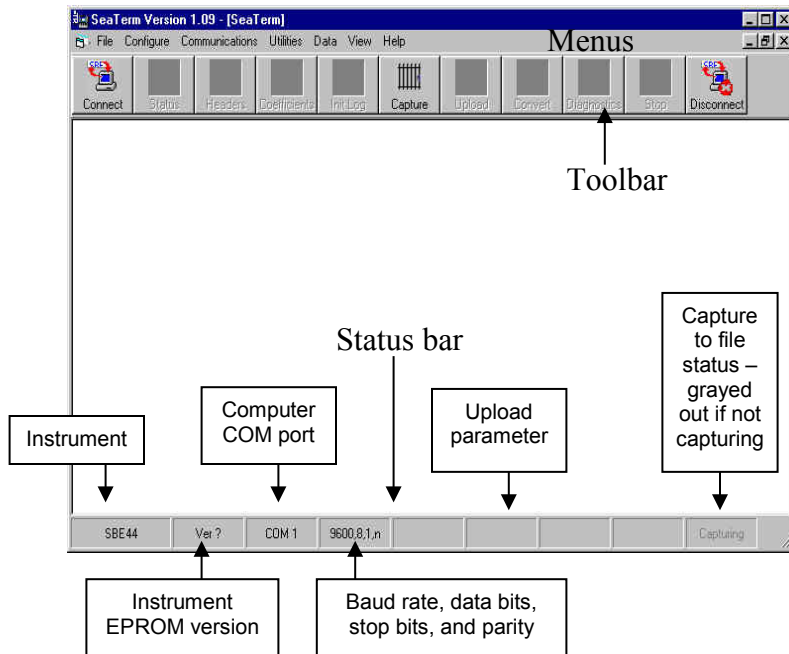

Note:
There is at least one way, and as many as three ways, to enter a command:

- Manually type a command in Command/Data Echo Area
- Use a menu to automatically generate a command
- Use a Toolbar button to automatically generate a command

Note:
Once the system is configured and connected (Steps 3 through 5 below), to update the Status bar:

- on the Toolbar, click Status; or
- from the Utilities menu, select Instrument Status.

Seaterm sends the status command, which displays in the Command/Data Echo Area, and updates the Status bar.

- **Menus** – Contains tasks and frequently executed instrument commands.
- **Toolbar** – Contains buttons for frequently executed tasks and instrument commands. All tasks and commands accessed through the Toolbar are also available in the Menus. To display or hide the Toolbar, select View Toolbar in the View menu. Grayed out Toolbar buttons are not applicable.
- **Command/Data Echo Area** – Echoes a command executed using a Menu or Toolbar button, as well as the instrument's response. Additionally, a command can be manually typed in this area, from the available commands for the instrument. The instrument must be *awake* for it to respond to a command (use Connect on the Toolbar to wake up the instrument).
- **Status bar** – Provides status information. To display or hide the Status bar, select View Status bar in the View menu.

Following are the Toolbar buttons applicable to the SBE 44:

Toolbar Buttons	Description	Equivalent Command*
Connect	Re-establish communications by sending wakeup tone to all SBE 44s. Computer responds with S> prompt. SBE 44s <i>go to sleep</i> after user-programmable timeout (!iiTimeOut – default is 120 sec) without communication from computer have elapsed.	PwrOn
Status	Display instrument setup status (timeout settings, power-up settings, etc.).	!iiDS
Capture	Capture instrument responses on screen to file. File has .cap extension. Press Capture again to turn off capture. Capture status displays in Status bar.	—
Disconnect	Free computer COM port used to communicate with SBE 44. COM port can then be used by another program.	—

*See *Command Descriptions* in Section 4: *Deploying and Operating SBE 44*.

3. In the Configure menu, select SBE 44. The dialog box looks like this:

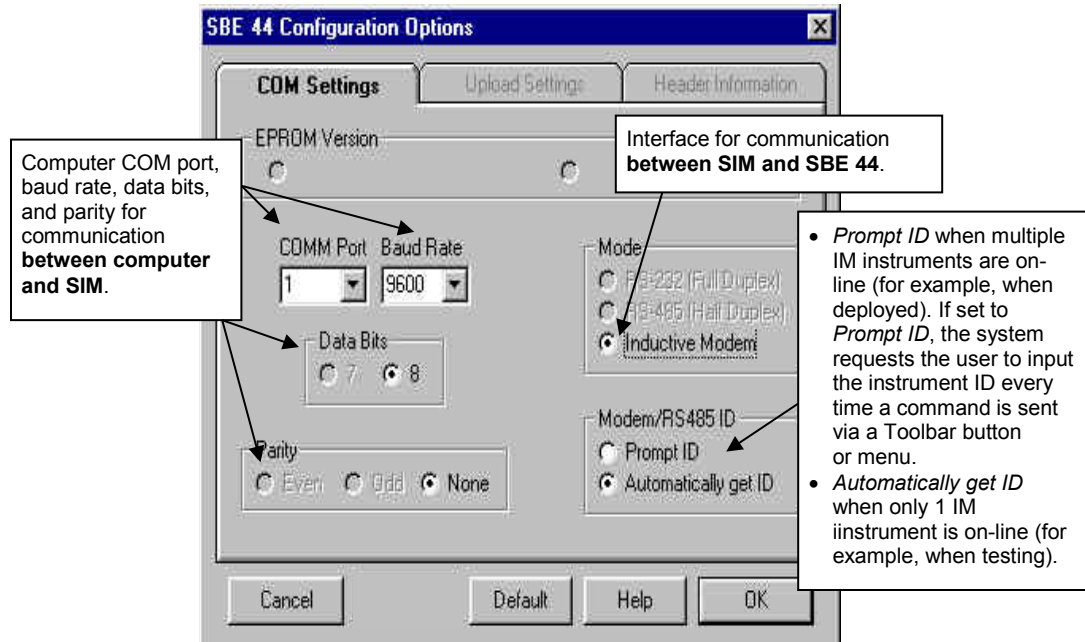

Notes:

- Seaterm’s baud must be the same as the SIM baud (set with **Baud=**). Baud is factory-set to 9600, but can be changed by the user (see *Command Descriptions* in Section 4: *Deploying and Operating SBE 44*).
- When you click OK, Seaterm saves the Configuration Options settings to the Seaterm.ini file in your Windows directory. Seaterm.ini contains the last saved settings for each instrument (SBE 37, 44, etc.). When you open Seaterm and select the desired instrument in the Configure menu, the Configuration Options dialog box shows the last saved settings for that instrument.
- When deploying on a mooring cable with multiple SBE 44s, change **Modem/RS485 ID** to **Prompt ID** after testing is complete.

Make the selections in the Configuration Options dialog box:

- **COM Port:** COM 1 through COM 10, as applicable
- **Baud Rate:** 1200, 2400, 4800, or 9600, as applicable
- **Data Bits:** 8
- **Parity:** None
- **Mode:** Inductive Modem
- **Modem/RS485 ID:** Automatically get I.D.

Click OK to save the settings.

Note:

The display shows 37 because the SIM was originally developed for the SBE 37-IM MicroCAT.

- Turn on the SIM power supply (if already on, turn it off and then on again). The display looks like this:

```
37 SURFACE MODEM V 3.0
S>
Sending wake up tone, wait 4 seconds
S>
```

This shows that correct communications between the computer and the SIM has been established, and the SIM has sent the wake-up signal to the SBE 44.

If the system does not respond as shown above:

- Click Connect on the Toolbar.
- Verify the correct instrument was selected in the Configure menu and the settings were entered correctly in the Configuration Options dialog box. The baud rate is documented on the Configuration Sheet.
- Check cabling between the computer, the SIM, and the SBE 44.

- Click Connect on the Toolbar. This allows the system to use the *Automatically get ID* feature when using the Toolbar keys or menus.

Note:

The SIM and SBE 44 have timeout algorithms designed to:

- restore control to the computer if an illegal command is sent
- conserve power if too much time elapses between commands

If the system does not respond, see *Timeout Descriptions* in *Section 4: Deploying and Operating SBE 44*.

- Confirm the SBE 44 has responded to the wake-up signal by typing **ID?** and pressing the Enter key. The display looks like this:

```
id=01
```

where 01 is the number set at the factory or by the previous user. See the Configuration Sheet for the factory-set identification (ID) number. The ID is stored in the SBE 44's EEPROM and can be changed so that multiple SBE 44s on a single mooring each have a unique ID.

Press the Enter key to get the S> prompt.

- Display SBE 44 status information by typing **!iIDS** (ii=SBE 44 ID) and pressing the Enter key. The display looks like this:

```
SBE 44 UNDERWATER MODEM V 1.9a
sensor baud rate = 9600
break character length = 500 milliseconds
time out after 30 seconds without receiving a valid command
termination character is 62, char =>
Relay Command Settings:
  relay termination characters = <CR><LF>
  total time for response = 15 seconds
  wait 0 milliseconds before sending the command
  halt relay after a gap of 1000 milliseconds between characters
GDATA Command Settings:
  total time for response = 30 seconds
  wait 0 milliseconds before sending the command
  halt acquisition after a gap of 1000 milliseconds between characters
GDATA command string = NO STRING
include gdata reply delay in datann reply
do not enable control line on power up
enable control line before relaying command
enable control line before sending GDATA command
do not switch power to sensor on power up
switch power to sensor before relaying command
switch power to sensor before sending GDATA command
```

Press the Enter key to get the S> prompt.

Note:

Steps 8 through 10 apply if you are connected to a second computer for testing purposes. If you are connected to the sensor (serial instrument), test the system using the commands described in *Command Descriptions* in *Section 4: Deploying and Operating SBE 44*.

8. **On Computer #2** – Set up Computer #2 as if it was an SBE 37 communicating with RS-232:
 - A. Double click on Seaterm.exe.
 - B. If the setup dialog box appears, select the instrument type (**SBE 37**) and the computer COM port for communication with the SBE 37. Click OK.
 - C. In the main screen's Configure menu, select **SBE 37**.
 - D. Make the selections in the Configuration Options dialog box:
 - **COMM Port:** COM 1 through COM 10, as applicable
 - **Baud Rate:** (baud rate reported as **sensor baud rate** from Computer #1 in Step 7)
 - **Data Bits:** 8
 - **Parity:** None
 - **Mode:** RS-232 (Full Duplex)
 - **Modem/RS485 ID:** (not applicable)
 Click OK to save the settings.

9. **On Computer #1** – Type **#iiSENORTEST** (ii=SBE 44 ID).

Note:

Characters sent **from** the serial instrument (or from Computer #2) **to** the SBE 44 must be greater than 09 decimal (09 Hex) and less than 123 decimal (7B Hex). Additionally, the @ symbol (64 decimal or 40 Hex) cannot be sent.

10. **On Computer #2** – Display should show **SENORTEST**. Immediately begin typing on Computer #2. The characters will echo on Computer #1, until **one** of the following end-of-relay conditions are met:
 - SIM times out (default for **RelayMax**, total time allowed for reply, is 20 sec)
 - SBE 44 times out (default for **!iiRTotalMax**, total time allowed for reply, is 15 sec)
 - SBE 44 receives a termination character (default for **!iiTermChar**, sensor reply termination character, is >)
 - SBE 44 detects a gap between received characters in the reply, which acts as a termination character (default for **!iiRTermMax**, maximum gap between characters in reply, is 1000 millisecond)

The remaining steps refer to commands on **Computer #1**.

Note:

If more than one IM instrument is on-line when you set the ID, all IM instruments will be set to the same ID. The inductive modem receivers in IM instruments are very sensitive; two IM instruments that are side-by-side will take the same ID, even if one of them is not on the IM loop. **Therefore, separate IM instruments by at least 2 meters when setting IDs.**

11. Each SBE 44 on a mooring must have a unique ID for communicating with the SIM and computer. Set the ID as described below, first verifying that only one SBE 44 is on-line before you set the ID:
 - A. Set the SBE 44 ID by typing ***ID=ii** (ii= user-assigned ID number) and pressing the Enter key.
 - B. The computer responds by requesting verification, requiring you to again type ***ID=ii** and press the Enter key.
 - C. Record the ID for future reference.
 - D. Press the Enter key to get the **S>** prompt.
 - E. Click Connect on the Toolbar. This allows the system to use the *Automatically get I.D.* feature when using the Toolbar keys or menus.
12. Send additional commands, as desired.
13. Command the SBE 44 to go to sleep (quiescent state) by typing **PwrOff** and pressing the Enter key.

The SBE 44 is ready for deployment.

Important! When testing and ID setting is complete for all the SBE 44s, reinstall the J5 jumper on the SIM PCB. The jumper must be installed for Normal Deployed operation.

Power and Communications Test and Setting SBE 44 IDs – Using Inductive Modem Module (IMM)

The power and communications test will verify that the system works, prior to deployment.

Test Setup with IMM

1. Loop insulated wire through the SBE 44's modem coupling core to simulate a mooring cable. Place the other end of the loop through the IMM test coupler (supplied with the IMM) or the ICC. Connect the wire ends from the IMM test coupler or ICC to the IMM's mooring cable terminals (J1) (see IMM Manual).
2. Sea-Bird recommends a minimum of 20 ohms impedance to reduce noise during testing.
3. Connect the IMM to your computer's serial port and to a 7 – 24 VDC power supply using the cable supplied with the IMM. A maximum of 15 mA is required.

Note:

If more than one IM instrument is on-line when you set the ID, all IM instruments will be set to the same ID. The inductive modem receivers in IM instruments are very sensitive; two IM instruments that are side-by-side will take the same ID, even if one of them is not on the IM loop. **Therefore, separate IM instruments by at least 2 meters when setting IDs.**

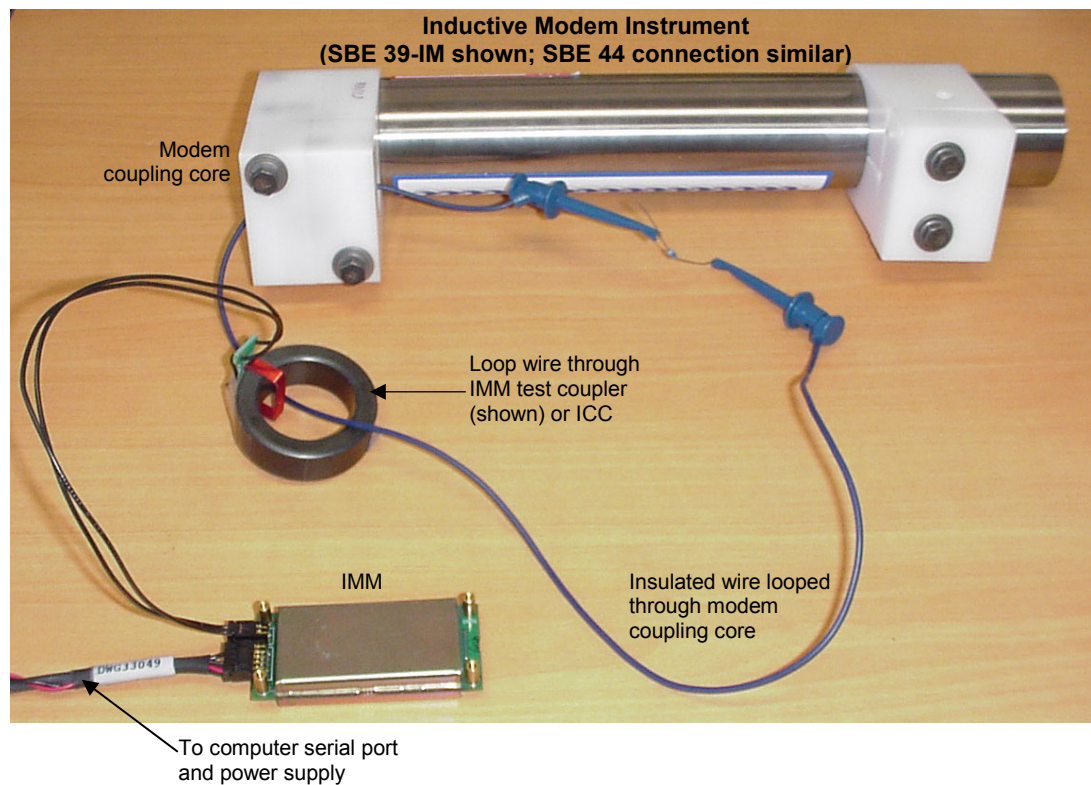

Note:

See the IMM manual for complete details on the use and setup of the IMM.

Setup of IMM for use with SBE 44

Sea-Bird recommends **one** of the following setups of the IMM for use with the SBE 44:

To make full use of IMM capabilities:

***Init**

***Init** (Resets IMM to factory default state [must be sent twice])

SetConfigType=2

SetEnableAutoIMFlag=0

SetEnableBackSpace=1

SetEnableBinaryData=0

SetEnableEcho=1

SetEnableHostFlagConfirm=0

SetEnableHostFlagTerm=0

SetEnableHostFlagWakeup=0

SetEnableHostPromptConfirm=0

SetEnableHostServeOnPwrUp=1

SetEnablePrompt=1

SetEnableHostWakeupCR=0

SetEnableSignalDetector=0

SetTermFromHost=36

SetTermToHost=13

To have the IMM emulate the SIM:

***Init**

***Init** (Resets IMM to factory default state [must be sent twice])

SetConfigType=1

SetEnableBinaryData=0

Verify that the IMM is set up as described by sending the **GetCD** command before proceeding with the SBE 44 setup.

A script including one of the above setups should be included in the buoy controller, to allow the IMM to be reset to the appropriate state if it becomes corrupted.

Test and Set SBE 44 ID Using SBE 44 with IMM

Note:

See Seaterm's Help files.

1. **On Computer #1** - Double click on Seaterm.exe. If this is the first time the program is used, the setup dialog box may appear:

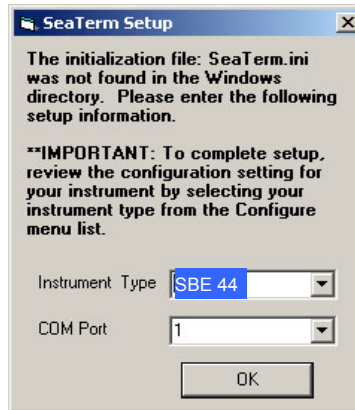

Select the instrument type (SBE 44) and the computer COM port for communication with the SBE 44. Click OK.

2. The main screen looks like this:

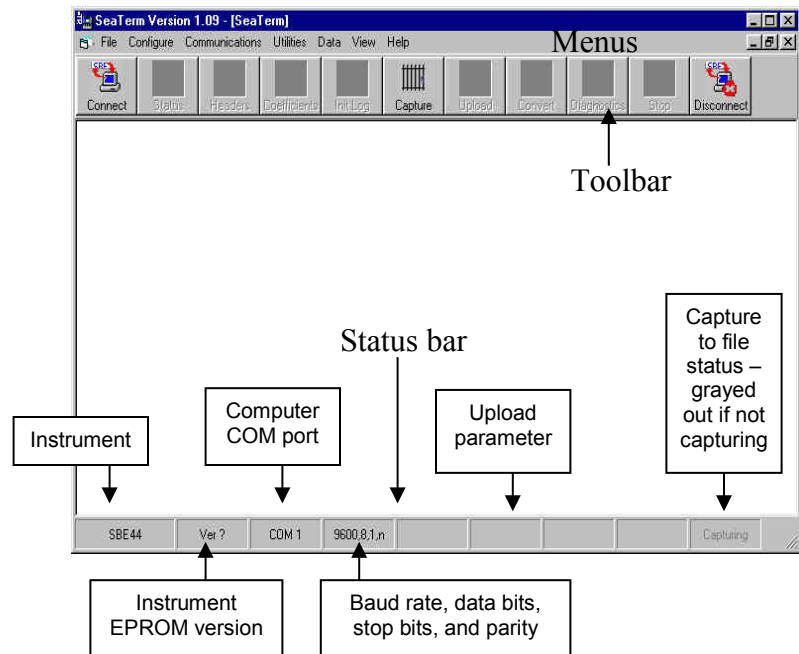
Note:

There is at least one way, and as many as three ways, to enter a command:

- Manually type a command in Command/Data Echo Area
- Use a menu to automatically generate a command
- Use a Toolbar button to automatically generate a command

Note:

Once the system is configured and connected (Steps 3 through 5 below), to update the Status bar:

- on the Toolbar, click Status; or
- from the Utilities menu, select Instrument Status.

Seaterm sends the status command, which displays in the Command/Data Echo Area, and updates the Status bar.

- **Menus** – Contains tasks and frequently executed instrument commands.
- **Toolbar** – Contains buttons for frequently executed tasks and instrument commands. All tasks and commands accessed through the Toolbar are also available in the Menus. To display or hide the Toolbar, select View Toolbar in the View menu. Grayed out Toolbar buttons are not applicable.
- **Command/Data Echo Area** – Echoes a command executed using a Menu or Toolbar button, as well as the instrument's response. Additionally, a command can be manually typed in this area, from the available commands for the instrument. The instrument must be *awake* for it to respond to a command (use Connect on the Toolbar to wake up the instrument).
- **Status bar** – Provides status information. To display or hide the Status bar, select View Status bar in the View menu.

Following are the Toolbar buttons applicable to the SBE 44:

Toolbar Buttons	Description	Equivalent Command*
Connect	Re-establish communications by sending wakeup tone to all SBE 44s. Computer responds with S> prompt. SBE 44s <i>go to sleep</i> after user-programmable timeout (!iiTimeOut – default is 120 sec) without communication from computer have elapsed.	PwrOn
Status	Display instrument setup status (timeout settings, power-up settings, etc.).	!iiDS
Capture	Capture instrument responses on screen to file. File has .cap extension. Press Capture again to turn off capture. Capture status displays in Status bar.	—
Disconnect	Free computer COM port used to communicate with SBE 44. COM port can then be used by another program.	—

*See *Command Descriptions* in Section 4: *Deploying and Operating SBE 44*.

3. In the Configure menu, select SBE 44 IM. The dialog box looks like this:

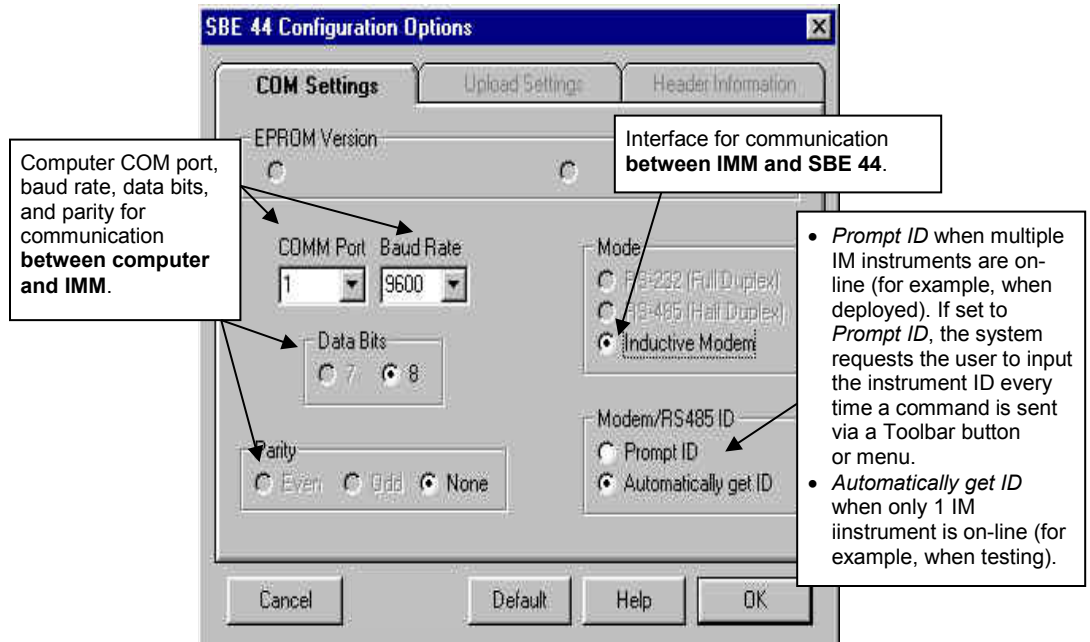

Notes:

- Seaterm’s baud must be the same as the IMM baud. The IMM baud is factory-set to 9600, but can be changed by the user (set with **Baud=** or **SetBaudRate=**; see IMM manual).
- When you click OK, Seaterm saves the Configuration Options settings to the Seaterm.ini file in your Windows directory. Seaterm.ini contains the last saved settings for each instrument (SBE 37, 44, etc.). When you open Seaterm and select the desired instrument in the Configure menu, the Configuration Options dialog box shows the last saved settings for that instrument.
- When deploying on a mooring cable with multiple SBE 44s, change **Modem/RS485 ID** to **Prompt ID** after testing is complete.

Make the selections in the Configuration Options dialog box:

- **COM Port:** COM 1 through COM 10, as applicable
 - **Baud Rate:** 1200, 2400, 4800, or 9600, as applicable (Note: The IMM can also communicate with the computer at 19200 baud, but the current version of Seaterm does not support this higher baud rate.)
 - **Data Bits:** 8
 - **Parity:** None
 - **Mode:** Inductive Modem
 - **Modem/RS485 ID:** Automatically get I.D.
- Click OK to save the settings.

4. Turn on the IMM power supply.
5. Send **GetHD** to get IMM status information.
6. Connect to the SBE 44 as follows:
 - If the IMM is set to **ConfigType=1**: Send **PwrOn** to wake up all IM instruments on the line.
 - If the IMM is set to **ConfigType=2**: Send **ForceCaptureLine** to reserve the IM line by transmitting a carrier signal. Then send **SendWakeupTone** to wake up all IM instruments on the line.
7. Confirm the SBE 44 has responded to the wake-up signal by typing **ID?** and pressing the Enter key. The display looks like this:

```
id=01
```

where 01 is the number set at the factory or by the previous user. See the Configuration Sheet for the factory-set identification (ID) number. The ID is stored in the SBE 44's EEPROM and can be changed so that multiple SBE 44s on a single mooring each have a unique ID.

8. Display SBE 44 status information by typing **!iIDS** (ii=SBE 44 ID) and pressing the Enter key. The display looks like this:

```
SBE 44 UNDERWATER MODEM V 1.9a
sensor baud rate = 9600
break character length = 500 milliseconds
time out after 30 seconds without receiving a valid command
termination character is 62, char =>
Relay Command Settings:
  relay termination characters = <CR><LF>
  total time for response = 15 seconds
  wait 0 milliseconds before sending the command
  halt relay after a gap of 1000 milliseconds between characters
GDATA Command Settings:
  total time for response = 30 seconds
  wait 0 milliseconds before sending the command
  halt acquisition after a gap of 1000 milliseconds between characters
  GDATA command string = NO STRING
include gdata reply delay in datann reply
do not enable control line on power up
enable control line before relaying command
enable control line before sending GDATA command
do not switch power to sensor on power up
switch power to sensor before relaying command
switch power to sensor before sending GDATA command
```

Note:

The IMM and SBE 44 have timeout algorithms designed to:

- restore control to the computer if an illegal command is sent
- conserve power if too much time elapses between commands

If the system does not appear to respond:

- If **ConfigType=1**: send **PwrOn**.
- If **ConfigType=2**: wait at least 1 sec, send **ForceCaptureLine**, and send **SendWakeupTone**.

See *Timeout Descriptions* in *Section 4: Deploying and Operating SBE 44* and the IMM manual.

9. **If there is no communication** (no response to **id?** and/or no response to **!iIDS**):
 - Verify the correct instrument was selected in the Configure menu and the settings were entered correctly in the Configuration Options dialog box. The baud rate is documented on the Configuration Sheet.
 - Check cabling between the computer, the IMM, and the SBE 44.

Note:

Steps 10 through 12 apply if you are connected to a second computer for testing purposes. If you are connected to the sensor (serial instrument), test the system using the commands described in *Command Descriptions* in *Section 4: Deploying and Operating SBE 44*.

10. **On Computer #2** – Set up Computer #2 as if it was an SBE 37 communicating with RS-232:
 - A. Double click on Seaterm.exe.
 - B. If the setup dialog box appears, select the instrument type (**SBE 44 IM**) and the computer COM port for communication with the SBE 44. Click OK.
 - C. In the main screen's Configure menu, select **SBE 44 IM**.
 - D. Make the selections in the Configuration Options dialog box:
 - **COMM Port:** COM 1 through COM 10, as applicable
 - **Baud Rate:** (baud rate reported as **sensor baud rate** from Computer #1 in Step 8)
 - **Data Bits:** 8
 - **Parity:** None
 - **Mode:** RS-232 (Full Duplex)
 - **Modem/RS485 ID:** (not applicable)
 Click OK to save the settings.
11. **On Computer #1** – Type **!iiSENORTEST** (ii=SBE 44 ID).
12. **On Computer #2** – Display should show **SENORTEST**. Immediately begin typing on Computer #2. The characters will echo on Computer #1, until **one** of the following end-of-relay conditions are met:
 - IMM times out (see IMM manual)
 - SBE 44 times out (default for **!iiRTotalMax**, total time allowed for reply, is 15 sec)
 - SBE 44 receives a termination character (default for **!iiTermChar**, sensor reply termination character, is >)
 - SBE 44 detects a gap between received characters in the reply, which acts as a termination character (default for **!iiRTermMax**, maximum gap between characters in reply, is 1000 millisec)

The remaining steps refer to commands on **Computer #1**.

Note:

If more than one IM instrument is on-line when you set the ID, all IM instruments will be set to the same ID. The inductive modem receivers in IM instruments are very sensitive; two IM instruments that are side-by-side will take the same ID, even if one of them is not on the IM loop. **Therefore, separate IM instruments by at least 2 meters when setting IDs.**

13. Each SBE 44 on a mooring must have a unique ID for communicating with the IMM and computer. Set the ID as described below, first verifying that only one SBE 44 is on-line before you set the ID:
 - A. Set the SBE 44 ID by typing ***ID=ii** (ii= user-assigned ID number) and pressing the Enter key.
 - B. The computer responds by requesting verification, requiring you to again type ***ID=ii** and press the Enter key.
 - C. Record the ID for future reference.
 - D. Click Connect on the Toolbar. This allows the system to use the *Automatically get I.D.* feature when using the Toolbar keys or menus.
14. Send additional commands, as desired.
15. Command the SBE 44 to go to sleep (quiescent state) by typing **PwrOff** and pressing the Enter key.

The SBE 44 is ready for deployment.

Section 4: Deploying and Operating SBE 44

This section includes system operation, example command sets, command descriptions, and instructions for deploying and recovering the SBE 44.

Operation Description

Commands sent to the IMM or SIM (both typically at the surface) can be directed to the IMM or SIM, SBE 44, or serial instrument (sensor). A command prefix that includes the SBE 44 ID (ii) directs commands to a specific SBE 44 or to the serial instrument connected to it. Global commands are recognized by all SBE 44s on the same inductive cable.

Command prefixes determine which part of the system decodes the commands. The table below shows the general form of the commands; see *Command Descriptions* for detailed information:

Command Form	Response
String	<i>String</i> is decoded by IMM or SIM.
!iiString	<i>String</i> is decoded by SBE 44 with ID=ii.
#iiString	<i>String</i> is decoded by serial instrument connected to SBE 44 with ID=ii. ASCII reply from serial instrument is transmitted through SBE 44 to IMM/SIM and computer/controller.
BiiString	<i>String</i> is decoded by serial instrument connected to SBE 44 with ID=ii. Binary reply from serial instrument is transmitted through SBE 44 to IMM/SIM and computer/controller. Note: The SBE 44's binary data capability is intended for use on a system with only one IM instrument online. A binary data reply <i>could</i> inadvertently include the equivalent of a valid command for other inductive modem instruments on line, causing other instruments to respond and thereby corrupting the data stream. Sea-Bird strongly recommends that you do not use the binary data capability with multiple inductive modem instruments online.
GData	Commands all SBE 44s to send pre-defined string to sensors. Each SBE 44 holds sensor reply in buffer until receiving Dataii.
Dataii	Directs SBE 44 with ID=ii to transmit data in its buffer to IMM/SIM and computer/controller.

The SBE 44 has a 30 Kbyte FIFO buffer, so the serial instrument response to any command is limited to 30,000 bytes.

Note:
 Characters sent **from** the serial instrument to the SBE 44 must be greater than 09 decimal (09 Hex) and less than 123 decimal (7B Hex). Additionally, the @ symbol (64 decimal or 40 Hex) cannot be sent. These limitations are not applicable to binary replies from the serial instrument.

Data can be requested and transmitted in several ways:

- A Relay command sends a user-defined command recognizable by the sensor. This command is sent to a specific SBE 44, which transmits the character string/break to the sensor. The sensor replies to the SBE 44, which immediately transmits the reply to the IMM/SIM and computer. Use a Relay command when you want data from a particular sensor at a particular time, and do not need to synchronize with data from other sensors. Relay commands include **#iiCmdString** (command string), **!iiSendCharW=x** (decimal value of character), **!iiSendBreak** (break character), and **BiiCmdString** (command string requesting a binary reply).

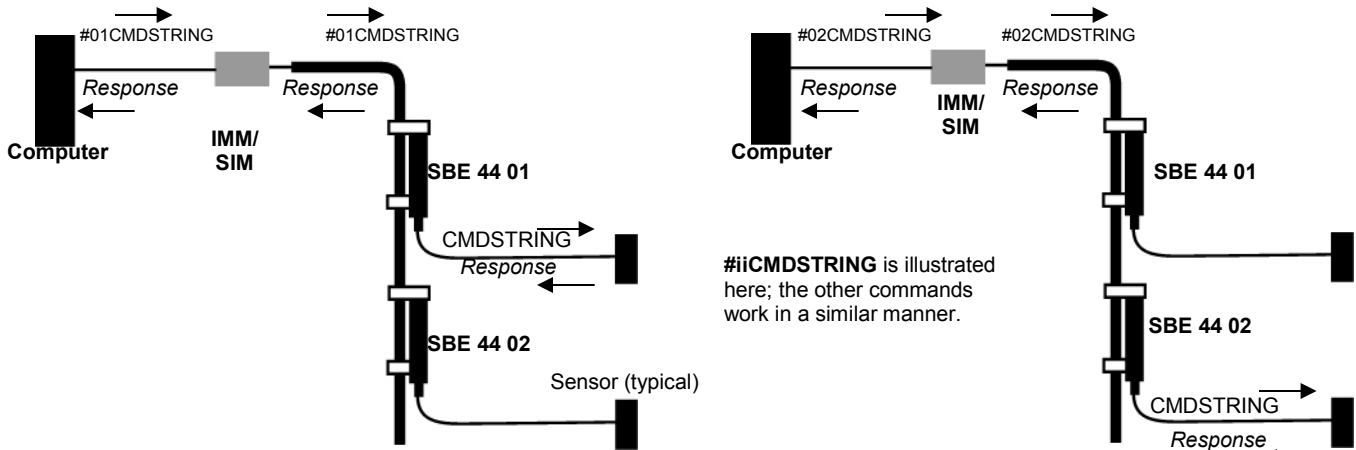

- A Get Data command sends a pre-defined character string recognizable by the sensor. A different character string can be pre-defined for each SBE 44 (and associated sensor). Get Data can be global (for all SBE 44s on the cable) or local (for a specific SBE 44). The SBE 44 transmits the character string to the sensor; the sensor replies to the SBE 44, which holds the reply in a buffer. **Dataii** gets the reply from a specific SBE 44 and transmits it to the IMM/SIM and computer. Use **GData**, the global Get Data command, when you want synchronized data from each SBE 44 on the cable.

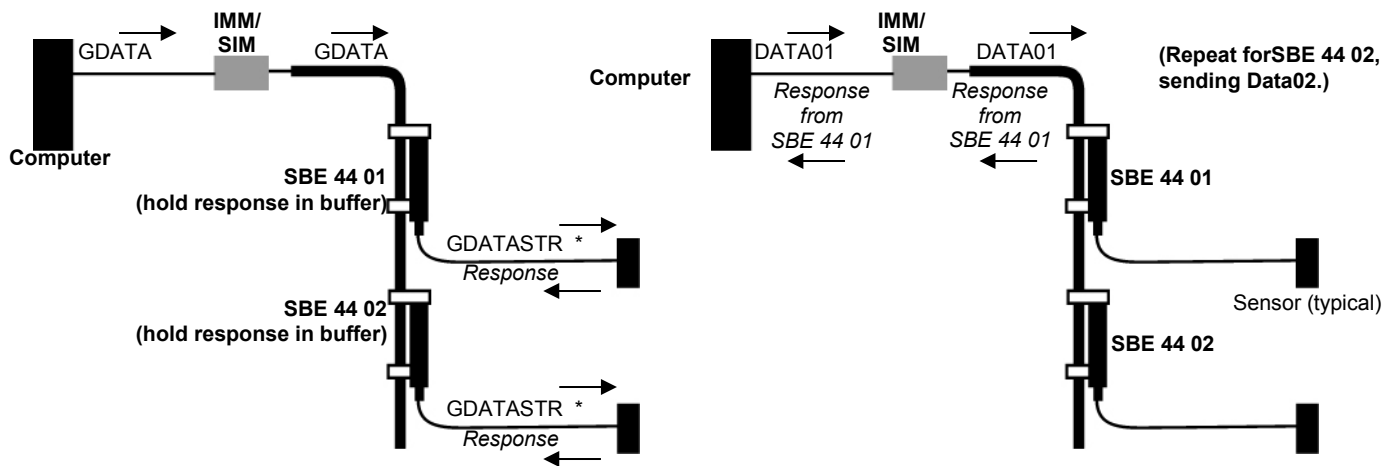

* GDATASTR is pre-defined by **!iiGDataSTR=** for each SBE 44. Note that a different string can be defined for each SBE 44.

Operating Modes

Note:

See *Appendix V: SBE 44 Interface PCB Configuration* for jumper settings for standard, switched power out, and control signal modes.

The SBE 44 has three basic operating modes that affect how power is provided to the serial instrument:

- **Standard** – The serial instrument is powered independent of the SBE 44. The instrument can be set up for continuous logging (if applicable), or intermittent commands to take samples can be sent through the SBE 44.
- **Optional Switched Power Out (pin 4 on bulkhead connector)** – The serial instrument is powered by the SBE 44's internal batteries or by optional external power input to the SBE 44 (pin 6). In this mode, power is applied to the instrument in one of the following ways:
 - On command (when **!iiSwPwrOn** command sent),
 - Automatically when SBE 44 powers on (if **!iiAutoSwPwrPON=Y**), **or**
 - Automatically when a Relay command (if **!iiAutoSwPwrRelay=Y**) or Get Data command (if **!iiAutoSwPwrGData=Y**) is sent.

This mode is not compatible with continuous logging by the instrument, because power is removed from the instrument when the SBE 44 enters the quiescent (sleep) state.
- **Optional Control Signal (pin 5 on bulkhead connector)** – The control signal can be 0 to 5 Volt or open collector, and is used to turn the serial instrument power on and off. In this mode, the control signal is enabled in one of the following ways:
 - On command (when **!iiCntlOn** command sent),
 - Automatically when SBE 44 powers on (if **!iiAutoCntlOn=Y**), **or**
 - Automatically when a Relay command (if **!iiAutoCntlRelay=Y**) or Get Data command (if **!iiAutoCntlGData=Y**) is sent.

This mode is not compatible with continuous logging by the instrument, because the control line is disabled when the SBE 44 enters the quiescent (sleep) state.

For each mode, data stored in the serial instrument's memory can be uploaded through the SBE 44 and IMM/SIM. Uploading data may require temporarily resetting system timeouts, to allow sufficient time for data transfer.

Commands can be used in various combinations to provide a high degree of operating flexibility. Review the operating modes, the examples, and the commands described in *Command Descriptions* before setting up your system.

Relay Command Operation

Action	Response		
	Standard Mode	Optional Switched Power	Optional Control Signal
1. SBE 44 powers on	-	If !iiAutoSwPwrPOn=Y , apply power to sensor.	If !iiAutoCntlPOn=Y , enable control line to sensor.
2. SBE 44 receives a command with its ID to be sent to sensor (#iiCmdString, where CmdString is command recognizable by sensor)	-	If !iiAutoSwPwrRelay=Y , apply power to sensor.	If !iiAutoCntlRelay=Y , enable control line to sensor.
	Wait !iiRStartWait millisecond.		
	Send command to sensor. Send reply to IMM/SIM until a Relay timeout condition is met.		
	-	If !iiAutoSwPwrRelay=Y , remove power from sensor.	If !iiAutoCntlRelay=Y , disable control line to sensor
3. SBE 44 powers down	-	If power not already removed from sensor, remove power from sensor.	If control line not already disabled, disable control line.

Get Data Command Operation

Action	Response		
	Standard Mode	Optional Switched Power	Optional Control Signal
1. SBE 44 powers on	-	If !iiAutoSwPwrPOn=Y , apply power to sensor.	If !iiAutoCntlPOn=Y , enable control line to sensor.
2. SBE 44 receives a global Get Data command (GData) or a Get Data command with its ID (!iiGData)	-	If !iiAutoSwPwrGData=Y , apply power to sensor.	If !iiAutoCntlGData=Y , enable control line to sensor.
	Wait !iiGStartWait millisecond.		
	Send command to sensor (as defined by !iiGDataStr=S).		
	Accept reply until a Get Data timeout condition is met. Store reply in SBE 44 buffer.		
	-	If !iiAutoSwPwrGData=Y , remove power from sensor.	If !iiAutoCntlGData=Y , disable control line to sensor
3. SBE 44 receives Dataii command	Send data held in SBE 44 buffer. Data in buffer is erased when SBE 44 powers down.		
4. SBE 44 powers down	-	If power not already removed from sensor, remove power from sensor.	If control line not already disabled, disable control line.

Examples

Shown below are examples of the three basic operating modes for a system with a **Surface Inductive Modem (SIM)** and **two SBE 44s (IDs 01 and 02)** on a mooring cable. The SBE 44's response to each command is not shown in the examples.

*Example: **Standard Operating Mode*** (user input in bold)

Example 1: Get Data Operation

Send wakeup tone to all SBE 44s. Pre-define data string to be sent to sensor when Get Data command is used. Data string can be any command understood by sensor (in example, TS is shown for sensor connected to SBE 44 01; SL is shown for sensor connected to SBE 44 02). Send power-off command to all SBE 44s.

```
S>PWRON  
S>! 01GDATASTR=TS  
S>! 02GDATASTR=SL  
S>PWROFF
```

Send wakeup tone to all SBE 44s. Get data from each sensor using the global Get Data command, and store sensor reply in each SBE 44's buffer. Send data from each SBE 44 to SIM and computer/controller. Send power-off command to all SBE 44s.

```
S>PWRON  
S>GDATA  
S>DATA01  
S>DATA02  
S>PWROFF
```

Example 2: Relay Command Operation

Send wakeup tone to all SBE 44s. Define data string to be sent to sensor now. Data string can be any command understood by sensor (in example, TS is shown for sensor connected to SBE 44 01; SL is shown for sensor connected to SBE 44 02). Sensor reply is sent to SIM and computer/controller. Send power-off command to all SBE 44s.

```
S>PWRON  
S>#01TS  
S>#02SL  
S>PWROFF
```

*Example: **Switched Power Mode*** (user input in bold)

Note: Switched power mode requires connection of serial instrument to pin 4 on SBE 44 bulkhead connector.

Example 1: Get Data Operation

Send wakeup tone to all SBE 44s. Pre-define data string to be sent to sensor when Get Data command is used. Data string can be any command understood by the sensor (in example, TS is shown for sensor connected to SBE 44 01; SL is shown for sensor connected to SBE 44 02). Set up each SBE 44 to switch power on to sensor automatically before relaying Get Data command string. Send power-off command to all SBE 44s.

```
S>PWRON
S>!01GDATASTR=TS
S>!02GDATASTR=SL
S>!01AUTOSWPWRGDATA=Y
S>!02AUTOSWPWRGDATA=Y
S>PWROFF
```

Send wakeup tone to all SBE 44s. Get data from each sensor using global Get Data command, and store sensor reply in each SBE 44's buffer. Send data from each SBE 44 to SIM and computer/controller. Send power-off command to all SBE 44s.

```
S>PWRON
S>GDATA
S>DATA01
S>DATA02
S>PWROFF
```

Example 2: Relay Command Operation

Send wakeup tone to all SBE 44s. Set up each SBE 44 to switch power on to sensor automatically before sending a Relay command. Send power-off command to all SBE 44s.

```
S>PWRON
S>!01AUTOSWPWRRELAY=Y
S>!02AUTOSWPWRRELAY=Y
S>PWROFF
```

Send wakeup tone to all SBE 44s. Define data string to be sent to sensor now. Data string can be any command understood by the sensor (in example, TS is shown for sensor connected to SBE 44 01; SL is shown for sensor connected to SBE 44 02). Sensor reply is sent to SIM and computer/controller. Send power-off command to all SBE 44s.

```
S>PWRON
S>#01TS
S>#02SL
S>PWROFF
```

Example: Control Line Mode (user input in bold)

Note: Control line mode requires connection of serial instrument to pin 5 on SBE 44 bulkhead connector

Example 1: Get Data Operation

Send wakeup tone to all SBE 44s. Pre-define data string to be sent to sensor when Get Data command is used. Data string can be any command understood by the sensor (in example, TS is shown for sensor connected to SBE 44 01; SL is shown for sensor connected to SBE 44 02). Set up each SBE 44 to enable control line automatically before relaying Get Data command string. Send power-off command to all SBE 44s.

```
S>PWRON
S>! 01GDATASTR=TS
S>! 02GDATASTR=SL
S>! 01AUTOCNTLGDATA=Y
S>! 02AUTOCNTLGDATA=Y
S>PWROFF
```

Send wakeup tone to all SBE 44s. Get data from each sensor using global Get Data command, and store sensor reply in each SBE 44's buffer. Send data from each SBE 44 to SIM and computer/controller. Send power-off command to all SBE 44s.

```
S>PWRON
S>GDATA
S>DATA01
S>DATA02
S>PWROFF
```

Example 2: Relay Command Operation

Send wakeup tone to all SBE 44s. Set up each SBE 44 to enable control line automatically before sending a Relay command. Send power-off command to all SBE 44s.

```
S>PWRON
S>! 01AUTOCNTLRELAY=Y
S>! 02AUTOCNTLRELAY=Y
S>PWROFF
```

Send wakeup tone to all SBE 44s. Define data string to be sent to sensor now. Data string can be any command understood by the sensor (in example, TS is shown for sensor connected to SBE 44 01; SL is shown for sensor connected to SBE 44 02). Sensor reply is sent to SIM and computer/controller. Send power-off command to all SBE 44s.

```
S>PWRON
S>#01TS
S>#02SL
S>PWROFF
```

Timeout Descriptions

Set user-programmable timeouts to allow proper operation of your serial instrument while minimizing the time the system is tied-up waiting for a response.

IMM Timeouts

For **IMM timeouts**, see the IMM manual.

SIM Timeouts

SIM timeouts restore control to the computer if no reply is received from the SBE 44 (for example, upon sending an illegal command) within a specified length of time, thereby allowing new commands to be sent:

- **DataNMax** – timeout that applies to **Dataii** only. Default is 1000 millisecond.
- **RelayMax** – timeout that applies to all other commands. Default is 20 sec.
- **BinaryGap** – termination timeout that applies to commands requesting binary response (**BiiCmdString**). Gap of **BinaryGap** since last byte received acts as termination character. Bytes sent after gap are ignored; control is returned to computer and other commands can be sent. Default is 1000 millisecond.

Note:

For proper system operation when transmitting binary data, **BinaryGap** in the SIM must be less than **!iiRTermMax** in the SBE 44. Sea-Bird recommends **!iiRTermMax** \geq **BinaryGap**+1000 msec.

When using RS-232 between the SIM and computer, control of the SIM can be re-established sooner than the timeout by pressing the Esc key and then the Enter key. When the S> prompt is displayed, new commands can be sent.

SBE 44 Timeouts

SBE 44 Power Down Timeout

If the SBE 44 does not receive a command for **!iiTimeOut** (default 120 sec), the SBE 44 communication circuits power down to prevent battery pack exhaustion. To re-establish control, send **PwrOn** or click Connect on the Toolbar.

Note:

ii = SBE 44 ID.

Relay Command (Send Command String, Character, or Break) Timeouts

Notes:

- **!iiTermChar=** is not applicable for binary sensor replies (replies to **BiiCmdString**).
- When transmitting binary data, set **!iiRTermMax** \geq **BinaryGap**+1000 msec for proper system operation.

Relay command timeouts are used to determine when the sensor reply to a Relay command is complete:

- **!iiTermChar** – If the SBE 44 receives a termination character, it ignores any additional characters received. Default is 62 ('>').
- **!iiRTermMax** – If the SBE 44 detects a gap between received characters in the reply, it is interpreted as a termination character, and the SBE 44 ignores any additional characters received. Default is 1000 millisecond.
- **!iiRTotalMax** – After a total of **!iiRTotalMax** seconds, the SBE 44 ignores any additional characters received. Default is 15 sec.

Get Data Command Timeouts

Get Data timeouts are used to determine when the sensor reply to a Get Data command is complete. These are applicable to the global Get Data (**GData**) and the Get Data sent to a specific SBE 44 (**!iiGData**):

- **!iiTermChar** – If the SBE 44 receives a termination character, it ignores any additional characters received. Default is 62 ('>').
- **!iiGTermMax** – If the SBE 44 detects a gap between received characters in the reply, it is interpreted as a termination character, and the SBE 44 ignores any additional characters received. Default is 1000 millisecond.
- **!iiGTotalMax** – After a total of **!iiGTotalMax** seconds, the SBE 44 ignores any additional characters received. Default is 15 sec.

Command Descriptions

Notes:

- If using the SBE 44 with a **Surface Inductive Modem (SIM)**: the SIM commands are included in this manual.
- If using the SBE 44 with an **Inductive Modem Module (IMM)**: see the IMM manual for details on IMM commands.

This section describes commands and provides sample outputs. See *Appendix III: Command Summary* for a summarized command list.

When entering commands:

- Input commands to the SBE 44 in upper or lower case letters and register commands by pressing the Enter key.
- The SBE 44 sends `? CMD` if an invalid command is entered.
- If the system does not return an `S>` prompt after executing a command, press the Enter key to get the `S>` prompt.
- If a new command is not received within **!iiTimeOut** (default 120 sec) after the completion of a command, the SBE 44 returns to the quiescent (sleep) state.
- If in quiescent state, re-establish communications by clicking Connect on the Toolbar, or
 - (if using SIM) sending **PwrOn**.
 - (if using IMM set to **ConfigType=1**) sending **PwrOn**.
 - (if using IMM set to **ConfigType=2**) waiting at least 1 sec, sending **ForceCaptureLine**, and sending **SendWakeupTone**.

SIM Commands

SIM commands are directed to the Surface Inductive Modem, to set it up for operation with the SBE 44.

Power-On Commands

PwrOn Send wakeup tone to **all** IM instruments on-line. Equivalent to Connect on Toolbar.

PwrOff Send power-off command to **all** IM instruments on-line. Main power turned off and IM instruments placed in quiescent (sleep) state. Any data in SBE 44 buffer is erased.

AutoPwrOn=x **x=Y** (default): Automatically send **PwrOn** to IM instruments on-line when power applied to SIM. This wakes up all IM instruments on-line.

x=N: Do not send **PwrOn** when power applied to SIM.

Note:

AutoPwrOn=N is typically used only with a *Tone Detect* board system; see *Appendix VI: Using SBE 44 with Tone Detect Board*.

Note:

The **DS** response shows **SBE 37** because the SIM was originally developed for the SBE 37-IM MicroCAT.

Status Command**DS**

Display SIM firmware version and status. Example includes command used to modify parameter [in parentheses].

Example: (user input in bold)

S>**DS**

SBE 37 SURFACE MODEM V 3.0

wait time for dataNN response = 1000 msec

[DataNNMax=]

wait time for relay command response = 20 seconds

[RelayMax=]

binary relay character timeout = 1000 msec

[BinaryGap=]

echo = yes

[EchoOn or EchoOff]

execute pwrOn command on powerup = yes

[AutoPwrOn=]

Communications Commands**Baud=x**

x= baud rate between SIM and computer / controller (1200, 2400, 4800, or 9600). Default 9600.

Note:

The SIM's baud rate (set with **Baud=**) must be the same as Seaterm's baud rate (set in the Configure menu).

DataNNMax=x

x= timeout (0-32767 millisecond; SIM rounds down to nearest 50 millisecond) that applies to **Dataii** only. If no reply received within **DataNNMax**, control returned to computer and other commands can be sent. Default 1000 millisecond.

RelayMax=x

x= timeout (0-3276 sec) that applies to all other commands. If no reply received within **RelayMax**, control returned to computer and other commands can be sent. Default 20 sec.

Note:

Set **!iiRTermMax** \geq **BinaryGap**+1000 msec for proper system operation when transmitting binary data.

BinaryGap=x

x= termination timeout (0 – 65535 millisecond) for commands requesting binary data (**BiiCmdString**). Gap of **BinaryGap** since last byte received acts as termination character. Bytes sent after gap ignored; control returned to computer and other commands can be sent. Default 1000 millisecond.

EchoOn

Echo characters received from computer (default) - computer monitor shows entered commands as you type.

EchoOff

Do not echo characters.

ID Commands

Note:
If more than one IM instrument is on-line when you set the ID, all IM instruments will be set to the same ID. The inductive modem receivers in IM instruments are very sensitive; two IM instruments that are side-by-side will take the same ID, even if one of them is not on the IM loop. **Therefore, separate IM instruments by at least 2 meters when setting IDs.**

Only one IM instrument can be on-line when sending these commands.

ID?	Display SBE 44 ID (ID = ii, where ii=0-99).
*ID=ii	Set SBE 44 ID to ii, where ii= 0-99. Must be sent twice, because verification requested. If more than one IM instrument is on-line, all IM instruments will be set to same ID.

SBE 44 and Sensor Commands

SBE 44 Status Commands

SBE 44 Status commands are preceded by **!ii** (ii = SBE 44 ID).

!iids	Display SBE 44 firmware version and setup parameters. Equivalent to Status on Toolbar. Example includes command used to modify parameter [in parentheses]:
--------------	--

```

Example: (user input in bold)
S>!01DS
SBE 44 UNDERWATER MODEM V 1.9a
sensor baud rate = 9600 [!iiBaud=]
break character length = 500 milliseconds [!iiBreakLen=]
time out after 30 seconds without receiving a valid command [!iiTimeOut=]
termination character is 62, char=> [!iiTermChar=]
Relay Command Settings:
  relay termination characters = <CR><LF> [!iiRelayTermChar=]
  total time for response = 15 seconds [!iiRTotalMax=]
  wait 0 milliseconds before sending the command [!iiRStartWait=]
  halt relay after a gap of 1000 milliseconds between characters [!iiRTermMax=]
GDATA Command Settings:
  total time for response = 30 seconds [!iiGTotalMax=]
  wait 0 milliseconds before sending the command [!iiGStartWait=]
  halt acquisition after a gap of 1000 milliseconds between characters [!iiGTermMax=]
  GDATA command string = NO STRING [!iiGDataStr=]
include gdata reply delay in datann reply [!iiIncGDataDelay=]
do not enable control line on power up [!iiAutoCntlPOn=]
enable control line before relaying command [!iiAutoCntlRelay=]
enable control line before sending GDATA command [!iiAutoCntlGData=]
do not switch power to sensor on power up [!iiAutoSwPwrPOn=]
switch power to sensor before relaying command [!iiAutoSwPwrRelay=]
switch power to sensor before sending GDATA command [!iiAutoSwPwrGData=]
send tone on powerup [!iiPOnTone=; this line appears only if !iiPOnTone=Y]
    
```

!ii*EETest	Test SBE 44's EEPROM, and reset all parameters to default values. Before performing test, record all parameters, so they can be reentered after test if desired.
-------------------	---

SBE 44 General Setup Commands

All SBE 44 General Setup commands are preceded by **!ii** (ii = SBE 44 ID).

Note:

The following parameters for communication between the SBE 44 and sensor cannot be modified:

- Data bits – 8
- Stop bits – 1
- Parity – none

!iiBaud=x

x= baud rate for serial communication **between SBE 44 and sensor** (300, 600, 1200, 2400, 4800, 9600, or 19200). Default 9600.

!iiRelayTermChar=x

x= decimal value (0-255) of **command termination character**. This allows user to specify what is appended to sensor command string for both Send Command String and Get Data commands. See *Appendix VII: Character Map and Values* for characters and decimal values. If x=**CRLF** (default), SBE 44 appends carriage return and line feed to relayed string. If x=**NONE**, SBE 44 does not append anything to relayed string.

Examples: (user input in bold)

S>**!01RELAYTERMCHAR=CRLF**

relay termination characters=<CR><LF>

S>**!01RELAYTERMCHAR=100**

relay termination character set to 100, char = d

S>**!01RELAYTERMCHAR=NONE**

no relay termination character

Note:

If the sensor is transmitting binary data in response to **BiiCmdString**, the SBE 44 ignores **!iiTermChar**.

!iiTermChar=x

x= decimal value (11-122) of **sensor reply termination character**. If SBE 44 receives a termination character, it ignores any additional characters received from sensor. Default is 62 (decimal value for '>'). See *Appendix VII: Character Map and Values* for characters and decimal values. If **!iiTermChar=NONE**, termination character checking is disabled.

!iiTimeOut=x

x= SBE 44 timeout (30-1800 sec). If no commands or replies are received for **!iiTimeOut**, SBE 44 automatically enters quiescent (sleep) state. **When SBE 44 enters quiescent state, any data held in its buffer is erased.** Default 120 sec.

Relay Commands

These commands set up the controls for and send commands relayed from the SBE 44 to the sensor. A Send Command String, Send Character, or Send Break command is sent to one SBE 44, which transmits it to the connected sensor. Unlike a Get Data command, the sensor response to these commands is sent immediately to the SBE 44, IMM/SIM, and computer/controller. Use a Relay command when you want to obtain data from a particular instrument at a particular time, and are not interested in synchronizing with data from other instruments.

Relay Setup Commands

These setup parameters apply to Send Command String, Send Character, and Send Break commands. Relay setup commands are preceded by **!ii** (ii = SBE 44 ID).

!iiRStartWait=x

x= command transmission delay after setting control line or switched power (0-32767 millisecond). Delaying transmission allows sensor to wake up before relaying command if **!iiAutoSwPwrRelay=Y** or **!iiAutoCntlRelay=Y**. Default 0.

Note:

Set

!iiRTermMax ≥ **BinaryGap**+1000 msec for proper system operation when transmitting binary data.

!iiRTermMax=x

x= termination timeout for sensor reply (0-32767 millisecond). Gap of **!iiRTermMax** after 2 characters have been received acts as termination character – characters sent by sensor after gap are ignored. Default 1000 millisecond.

!iiRTotalMax=x

x= total time allowed for sensor reply (0-600 sec). Characters sent by sensor after **!iiRTotalMax** are ignored. Default 15 sec.

Send Command String Commands

#iiCmdString

Command SBE 44 to send string defined by **CmdString** to sensor. **CmdString** can be any character string recognized by sensor. SBE 44 can append carriage return and line feed or character (defined by **!iiRelayTermChar**) to **CmdString**. Response is sent through SBE 44 to IMM/SIM and computer/controller.

Note:

The SBE 44's binary data capability is intended for use on a system with only one inductive modem instrument online. A binary data reply *could* inadvertently include the equivalent of a valid command for other inductive modem instruments on line, causing other instruments to respond and thereby corrupting the data stream. **Sea-Bird strongly recommends that you do not use the binary data capability with multiple inductive modem instruments online.**

BiiCmdString

Command SBE 44 to send character string defined by **CmdString** to sensor. **CmdString** can be any character string recognized by sensor that requests a **binary** response. SBE 44 can append carriage return and line feed or character (defined by **!iiRelayTermChar**) to **CmdString**. Binary response is sent through SBE 44 to IMM/SIM and computer/controller; any reply termination characters (defined by **!iiTermChar**) are ignored.

Send Character Commands

Send Character commands allow you to send a single character (including a *non-printing* character) to a sensor. These commands are preceded by **!ii** (ii = SBE 44 ID). Termination character parameter **!iiRelayTermChar** does not apply to these commands.

!iiSendCharW=x Command SBE 44 to send character defined by decimal value **x** to sensor. Character can be any command recognized by sensor. Response is sent through SBE 44 to IMM/SIM and computer/controller.

!iiSendChar=x Command SBE 44 to send character defined by decimal value **x** to sensor. Character can be any command recognized by sensor. **Command should be one that does not require response; SBE 44 does not accept any response from sensor, and is immediately ready to accept another command.**

Examples: (user input in bold)

S> **!01SENDCHARW=101**

(send lower case e; wait for a reply from sensor)

S> **!01SENDCHAR=100**

(send lower case d; do not wait for reply from sensor)

Send Break Commands

These commands set up and send a break character, which may be a signal to some types of sensors to send data. These commands are preceded by **!ii** (ii = SBE 44 ID).

!iiBreakLen=x **x**= length of break character (0-32750 millisecc). Default 1000 millisecc.

!iiSendBreak Command SBE 44 to send break character, as defined by **!iiBreakLen**, to sensor. Termination character parameter **!iiRelayTermChar** does not apply to this command. Response is sent through SBE 44 to IMM/SIM and computer/controller.

Get Data Commands

These commands set up controls for and transmit Get Data commands. **GData** or **!iiGData** sends the command pre-defined by **!iiGDataStr=** from the SBE 44 to the sensor. The sensor reply is held in the SBE 44 buffer until **Dataii** is sent. Use the global Get Data (**GData**) to obtain synchronized data from all sensors connected to SBE 44s on the mooring cable.

Get Data Setup Commands - all preceded by **!ii** (ii = SBE 44 ID).

!iiGStartWait=x	x= command transmission delay (after setting control line or switched power) (0-32767 millisecond). Delaying transmission allows sensor to wake up before relaying command if !iiAutoSwPwrGData=Y or !iiAutoCntlGData=Y . Default 0.
!iiGTermMax=x	x= termination timeout for sensor reply (0-32767 millisecond). Gap of !iiGTermMax after 2 characters acts as termination character – characters sent by sensor after gap ignored. Default 1000 millisecond.
!iiGTotalMax=x	x= time allowed for sensor reply (0-600 sec). Characters sent by sensor after !iiGTotalMax ignored. Default 30 sec.
!iiIncGDataDelay=x	x=Y (default): In Dataii reply, include number of 0.1-sec ticks received while waiting for GData or !iiGData reply. May be helpful in verifying sensor / buoy controller clock synchronization. x=N : Do not include number of ticks.
!iiGDataStr=S	S= character string sent to sensor (any command recognized by sensor) in response to GData or !iiGData . SBE 44 can append carriage return and line feed or a character (defined by !iiRelayTermChar) to string. !iiGDataStr= followed by Enter key disables sending string. Default no string (disabled).

Get Data Commands *continued*

Get Data Commands**Note:**

Data in the SBE 44 buffer is erased when the SBE 44 enters quiescent (sleep) state. Always send **Dataii** to transmit data in the buffer before the SBE44 timeout (**!iiTimeOut**) automatically puts the SBE 44 to sleep and before sending **PwrOff** to put the SBE 44 to sleep.

GData

Command **all** SBE 44s to send character string defined by **!iiGDataStr** to sensor. Each SBE 44 holds sensor reply in buffer until receiving **Dataii**.

If using IMM with ConfigType=2 at surface: Use **SendGData** instead; this results in IMM sending **Gdata** to all IM instruments on-line.

!iiGData

Command SBE 44 with ID=**ii** to send character string defined by **!iiGDataStr** to sensor. SBE 44 holds sensor reply in buffer until receiving **Dataii**.

Dataii

Get data obtained with **GData** or **!iiGData** from buffer of SBE 44 with ID = **ii**. Response sent to IMM/SIM and computer/controller.

If using IMM at surface: Use **!iiData** instead. **Dataii** is not compatible with IMM.

Switched Power Setup Commands

Note:

See *Appendix V: SBE 44 Interface PCB Configuration* for required jumper settings on the SBE 44's Interface PCB.

These commands set up controls for optional switched power operation (pin 4 on bulkhead connector). All commands are preceded by **!ii** (**ii** = SBE 44 ID).

!iiSwPwrOn

Switch power on to sensor now. Power to sensor remains on while SBE 44 remains awake. When SBE 44 enters quiescent (sleep) state, power to sensor switches off.

!iiSwPwrOff

Switch power off to sensor now.

!iiAutoSwPwrPON=x

x=Y: Switch power on to sensor automatically each time SBE 44 powers on. When SBE 44 enters quiescent (sleep) state, power to sensor switches off automatically. Entering this command **does not** switch power on now.

x=N (default): Do not switch power on to sensor automatically.

!iiAutoSwPwrGData=x

x=Y: Switch power on to sensor automatically before sending Get Data command string (**!iiGDataStr**) to sensor. Power to sensor switches off automatically when sensor response ends.

x=N (default): Do not switch power on to sensor automatically.

!iiAutoSwPwrRelay=x

x=Y: Switch power on to sensor automatically before sending Relay command (**#iiCmdString**, **!iiSendCharW=**, **!iiSendChar=**, or **!iiSendBreak**) to sensor. Power to sensor switches off automatically when sensor response ends.

x=N (default): Do not switch power on to sensor automatically.

Control Line Setup Commands

Note:

See *Appendix V: SBE 44 Interface PCB Configuration* for required jumper settings on the SBE 44's Interface PCB.

These commands set up the controls for optional control line operation (pin 5 on bulkhead connector). All commands are preceded by **!ii** (ii = SBE 44 ID).

!iiCntlOn	Enable control line to sensor now. Control line to sensor remains enabled while SBE 44 remains awake. When SBE 44 enters quiescent (sleep) state, control line to sensor is disabled.
!iiCntlROff	Disable control line to sensor now.
!iiAutoCntlPOn=x	<p>x=Y: Enable control line to sensor automatically each time SBE 44 powers on. When SBE 44 enters quiescent (sleep) state, control line to sensor disables automatically. Entering this command does not enable control line now.</p> <p>x=N (default): Do not enable control line to sensor automatically each time SBE 44 powers on.</p>
!iiAutoCntlGData=x	<p>x=Y: Enable control line to sensor automatically before sending Get Data command string (!iiGDataStr) to sensor. Control line to sensor disables automatically when sensor response ends.</p> <p>x=N (default): Do not enable control line to sensor automatically before sending Get Data command string to sensor.</p>
!iiAutoCntlRelay=x	<p>x=Y: Enable control line to sensor automatically before sending Relay command (#iiCmdString, !iiSendCharW=, !iiSendChar=, or !iiSendBreak) to sensor. Control line to sensor disables automatically when sensor response ends.</p> <p>x=N (default): Do not enable control line to sensor automatically before sending Relay command to sensor.</p>

Surface Tone Detect Commands

Note:

A surface *Tone Detect* board can be supplied by Sea-Bird. See *Appendix VI: Using SBE 44 with Tone Detect Board*.

This command sets up the controls for when the system is used with a surface *Tone Detect* board to signal the surface controller electronics. A typical use is for a system where the serial instrument needs to indicate that it has completed sampling and is ready to transmit data:

1. When it has completed sampling, the serial instrument pulls the detect line low on the SBE 44, powering the SBE 44 on.
2. The SBE 44 waits 2.5 sec, enables its transmitter, transmits a 4800 Hz tone for 2.5 sec, and then turns off its transmitter.
3. The 4800 Hz tone is received by the surface *Tone Detect* board, which then signals the computer/controller.
4. The computer/controller sends the appropriate commands through the IMM/SIM to the SBE 44 to get the data from the serial instrument.

!iiPOnTone=x

x=Y: Enable surface tone detect. After powering on, SBE 44 waits 2.5 sec, enables its transmitter, transmits 4800 Hz tone for 2.5 sec, and then turns off its transmitter.

x=N: Do not enable surface tone detect; do not send a tone on power up. Default.

Setup for Deployment

1. Install new AA lithium cells or ensure the existing battery pack has enough capacity to cover the intended deployment (see *Replacing Batteries* in *Section 5: Routine Maintenance*).
2. Program the SBE 44 for the intended deployment (see *Section 3: Preparing SBE 44 for Deployment* for connection information; see information in this section on operation and commands):
 - A. Establish the system operating parameters.
 - B. If the system will have multiple IM instruments on the mooring cable (SBE 44s and/or SBE 37-IM/IMP/IMP-IDO/IMP-ODO MicroCAT, 39-IM, 16/16plus-IM/16plus-IM V2 SeaCAT, UIMM), verify the SBE 44 is set to *Prompt ID* to allow use of the Toolbar buttons and Menus:
 - 1) In the Configure menu, select SBE 44.
 - 2) Click on the COM Settings tab.
 - 3) For Modem/RS485 ID, click on *Prompt ID*.
 - 4) Click OK.

SBE 44 Deployment

Note:

See *Application Note 85: Handling of Ferrite Core on Instruments with Inductive Modem Telemetry* for more detailed information on handling and installation.

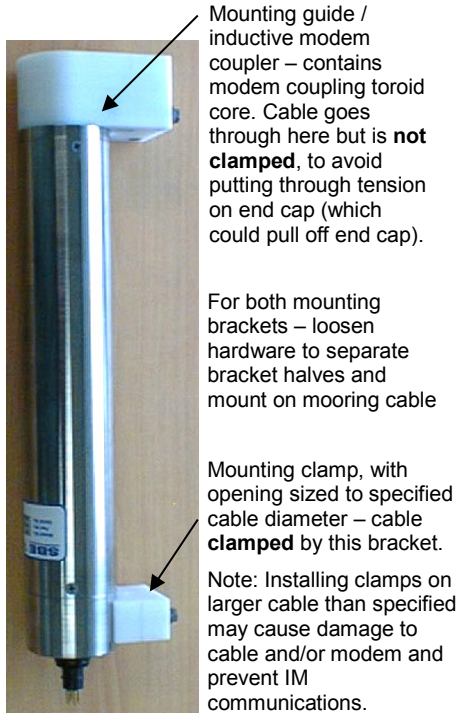

For both mounting brackets – loosen hardware to separate bracket halves and mount on mooring cable

For proper communications, 2 halves of modem coupling toroid core must mate, with no gaps

The SBE 44 comes with pre-installed Sea-Bird mounting brackets.

1. Attach the mounting brackets to the insulated mooring cable:
 - A. Open each mounting bracket by unthreading the two large titanium hex bolts.
 - B. Place the insulated mooring cable inside the brackets' grooves.
 - C. Reinstall each bracket half with the hex bolts.
 - D. Verify that the two halves of the modem coupling toroid have come together evenly, and that the mounting clamp is secure.

Mounting guide / Inductive Modem Coupler Detail

Guide is sized *slightly* bigger than specified cable diameter, to allow cable to pass through freely but limit vibration of SBE 44 on cable

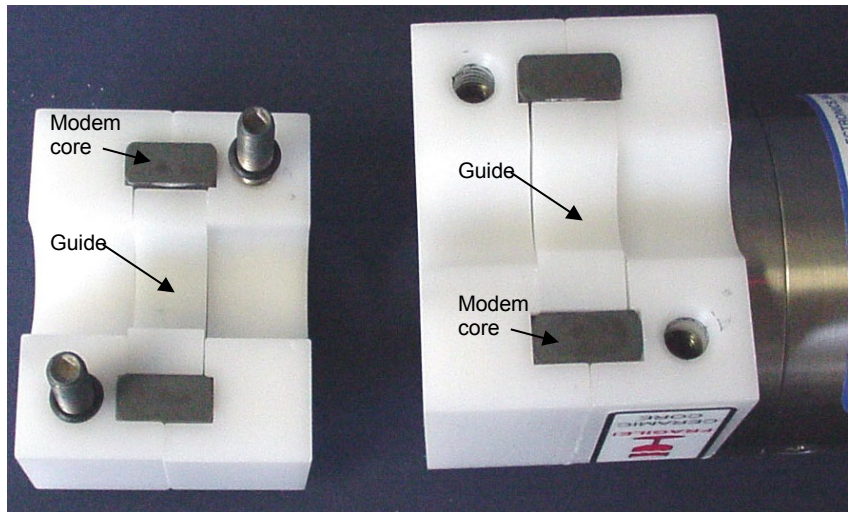

CAUTIONS:

- Do not use **WD-40** or other petroleum-based lubricants, as they will damage the connectors.
- For wet-pluggable MCBH connectors: **Silicone lubricants in a spray can** may contain ketones, esters, ethers, alcohols, or glycols in their propellant. **Do not use these sprays, as they will damage the connector.**

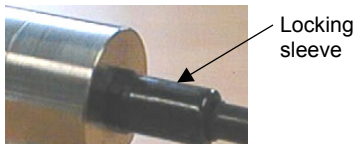
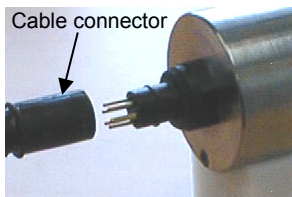

2. Verify that the hardware and external fittings are secure.
3. Install the serial instrument cable on the SBE 44:
 - A. Lightly lubricate the inside of the cable connector with silicone grease (DC-4 or equivalent).
 - B. **AG Connector** (shown in photos) - Install the cable connector, aligning the raised bump on the side of the connector with the large pin (pin 1 - ground) on the SBE 44. Remove any trapped air by *burping* or gently squeezing the plug/connector near the top and moving your fingers toward the end cap. **OR** **MCBH Connector** – Install the cable connector, aligning the pins
 - C. Place the locking sleeve over the connector. Tighten the locking sleeve finger tight only. **Do not overtighten the locking sleeve and do not use a wrench or pliers.**
4. Attach the other end of the cable to the serial instrument.
5. Deploy the SBE 44.

System Installation and Wiring

For system installation and wiring details, refer to:

- *Mooring Cable and Wiring Requirements* in *Section 2: Description of SBE 44*.
- *Appendix IV: SIM Hookup and Configuration* or *IMM manual*.
- *Appendix V: SBE 44 Interface PCB Configuration*.
- *Appendix VI: Using SBE 44 with Tone Detect Board*.

Installing Optional Inductive Cable Coupler (ICC)

1. Loosen the titanium hex head bolts connecting the two halves of each of the ICC brackets. Pull the halves apart.
2. Place the insulated mooring cable inside the brackets' grooves.
3. Reinstall each bracket half with the hex bolts.
4. Verify that the two halves of the modem coupling toroid have come together evenly, and that the mounting clamp is secure.

Note:

See *Application Note 85: Handling of Ferrite Core on Instruments with Inductive Modem Telemetry* for more detailed information on handling and installation.

Mounting clamp, with opening sized to specified cable diameter – cable **clamped** by this bracket.

Note: Installing clamps on larger cable than specified may cause damage to cable and/or modem and prevent IM communications.

Mounting guide / inductive modem coupler – contains modem coupling toroid. Cable goes through here but is **not clamped**, to avoid putting through tension on end cap (which could pull off end cap). **Detail of guide and core is similar to shown above for the SBE 44 guide and core.**

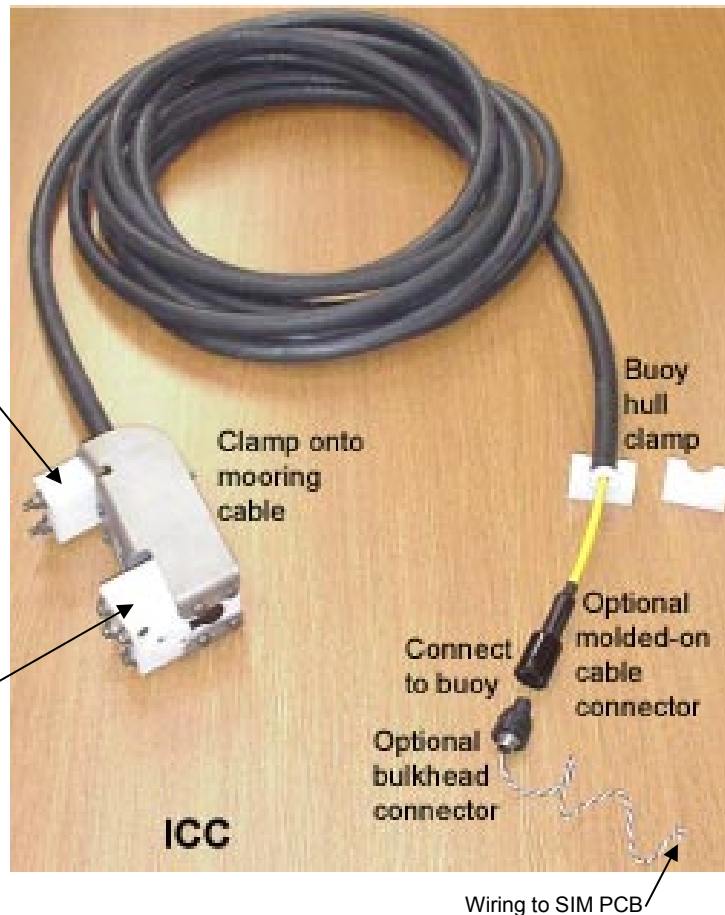

Recovery

WARNING!

If the SBE 44 stops working while underwater, is unresponsive to commands, or shows other signs of flooding or damage, carefully secure it away from people until you have determined that abnormal internal pressure does not exist or has been relieved. Pressure housings may flood under pressure due to dirty or damaged o-rings, or other failed seals. When a sealed pressure housing floods at great depths and is subsequently raised to the surface, water may be trapped at the pressure at which it entered the housing, presenting a danger if the housing is opened before relieving the internal pressure. Instances of such flooding are rare. However, a housing that floods at 5000 meters depth holds an internal pressure of more than 7000 psia, and has the potential to eject the end cap with lethal force. A housing that floods at 50 meters holds an internal pressure of more than 85 psia; this force could still cause injury.

If you suspect the SBE 44 is flooded, point it in a safe direction away from people, and loosen the bulkhead connector very slowly, at least 1 turn. This opens an o-ring seal under the connector. Look for signs of internal pressure (hissing or water leak). If internal pressure is detected, let it bleed off slowly past the connector o-ring. Then, you can safely remove the end cap.

1. Rinse the SBE 44 with fresh water.
2. If immediate redeployment is not required:
 - Remove the SBE 44's batteries (all setup parameters will be saved in EEPROM), **or**
 - Leave the SBE 44 with batteries in place and in a quiescent state (**PwrOff**). Because the quiescent current required is less than 100 microAmps, the battery pack can be left in place without significant loss of capacity.
3. If immediate redeployment is required and the battery pack is exhausted, install new cells. See *Section 5: Routine Maintenance* for cell replacement.

Section 5: Routine Maintenance

This section reviews corrosion precautions, AA cell replacement, connector mating and maintenance, and O-ring maintenance.

Corrosion Precautions

All exposed metal is titanium; other materials are plastic. No corrosion precautions are required, but avoid direct electrical connection of the SBE 44 housing to mooring or other dissimilar metal hardware. Rinse the SBE 44 with fresh water after use and prior to storage.

Replacing AA cells

Notes:

- For details and photos, see *Installing Battery Pack* in *Section 3: Preparing SBE 44 for Deployment*.
- **Only use the battery pack with the red cover plate.** Some MicroCATs use a battery pack with a yellow cover plate; those packs are wired differently, and **cannot be used with the SBE 44.**
- Cells must be removed before returning the SBE 44 to Sea-Bird. Do not return used cells to Sea-Bird when shipping the SBE 44 for calibration or repair.
- See *Shipping Precautions* in *Section 1: Introduction*.

1. Remove the 2 screws holding the modem end cap to the SBE 44 housing, and remove the end cap.
2. Loosen the captured screw holding the battery pack in the housing, and remove the battery pack from the housing.
3. Place the handle in an upright position. Unscrew the red cover plate from the top of the battery pack assembly.
4. Roll the 2 O-rings on the outside of the pack out of their grooves.
5. Remove the existing cells. Install new cells, positive end (+) first.
6. Roll the O-rings into place in the grooves on the side of the battery pack.
7. Place the handle in an upright position. Reinstall the battery pack cover plate.
8. Replace the battery pack assembly in the housing, and secure the assembly with the captured screw. Plug in the Molex connector, and reinstall the SBE 44 end cap.

Connector Mating and Maintenance

Note:

See *Application Note 57: Connector Care and Cable Installation*.

Clean and inspect the connectors, cable, and dummy plug before every deployment and as part of your yearly equipment maintenance. Inspect connectors that are unmated for signs of corrosion product around the pins, and for cuts, nicks or other flaws that may compromise the seal.

CAUTIONS:

- **Do not use WD-40** or other petroleum-based lubricants, as they will damage the connectors.
- For wet-pluggable MCBH connectors: **Silicone lubricants in a spray can** may contain ketones, esters, ethers, alcohols, or glycols in their propellant. **Do not use these sprays, as they will damage the connector.**

When remating:

1. Lightly lubricate the inside of the dummy plug/cable connector with silicone grease (DC-4 or equivalent).
2. **AG Connector** - Install the plug/cable connector, aligning the raised bump on the side of the plug/cable connector with the large pin (pin 1 - ground) on the SBE 44. Remove any trapped air by *burping* or gently squeezing the plug/connector near the top and moving your fingers toward the end cap. **OR**
MCBH Connector – Install the plug/cable connector, aligning the pins.
3. Place the locking sleeve over the plug/cable connector. Tighten the locking sleeve finger tight only. **Do not overtighten the locking sleeve and do not use a wrench or pliers.**

Verify that a cable is installed before deployment.

O-Ring Maintenance

Note:

For details on recommended practices for cleaning, handling, lubricating, and installing O-rings, see the *Basic Maintenance of Sea-Bird Equipment* module in the Sea-Bird training materials: www.seabird.com/training/TrainingHandouts.htm.

Recommended inspection and replacement schedule:

- For modem end cap O-rings – inspect each time you open the housing to replace the cells; replace approximately once a year.
- For O-rings that are not normally disturbed (for example, on the connector end cap) - approximately every 3 to 5 years.

Remove any water from the O-rings and mating surfaces in the housing with a lint-free cloth or tissue. Inspect O-rings and mating surfaces for dirt, nicks, and cuts. Clean or replace as necessary. Apply a light coat of O-ring lubricant (Parker Super O Lube) to O-rings and mating surfaces.

Section 6: Troubleshooting

This section reviews common problems in operating the SBE 44, and provides the most common causes and solutions.

Problem 1: Unable to Communicate with SBE 44

The `S>` prompt indicates that communications between the SBE 44 and computer have been established. Before proceeding with troubleshooting, attempt to establish communications again by clicking Connect on Seaterm's toolbar or pressing the Enter key several times.

Cause/Solution 1: The I/O cable connection may be loose. Check the cabling between the IMM/SIM and computer for a loose connection.

Cause/Solution 2: The instrument type and/or its communication settings may not have been entered correctly in Seaterm. Select the *SBE 44* in the Configure menu and verify the settings in the Configuration Options dialog box. The settings should match those on the instrument Configuration Sheet.

Cause/Solution 3: The I/O cable between the IMM/SIM and computer may not be the correct one. The I/O cable supplied with the IMM/SIM permits connection to standard 9-pin RS-232 interfaces.

Cause/Solution 4: The modem core in the SBE 44 (and/or the ICC, if applicable) may have a gap, be misaligned, or be damaged. See *Application Note 85: Handling of Ferrite Core in Instruments with Inductive Modem Telemetry* for details on inspecting the modem core and proper installation of the SBE 44 and the ICC (if applicable) on the cable.

Glossary

Battery pack – 12 AA lithium cells in a battery holder that connects 2 cells in series and each series string in parallel. Battery pack uses:

- Saft LS 14500, AA, 3.6 V and 2.45 Amp-hours each (www.saftbatteries.com) (**recommended**),
- Tadiran TL-4903, AA, 3.6 V and 2.4 Amp-hours each (www.tadiran.com), or
- Electrochem 3B0064/BCX85, AA, 3.9 V and 2.0 Amp-hours each (www.electrochemsolutions.com)

Character String - A group or sequence of characters, with no internal spaces. Letters of the alphabet, numbers, and punctuation symbols are characters.

ICC – Inductive Cable Coupler, which clamps to the insulated mooring cable and transfers the inductive signal on the wire to the SIM PCB installed inside the buoy or elsewhere.

IMM – Inductive Modem Module PCB, used to interface between the computer serial port and SBE 44s or other compatible IM instruments. Either an IMM or SIM is required to interface with the SBE 44.

PCB – Printed Circuit Board.

Scan – One data sample.

Note:

All Sea-Bird software listed was designed to work with a computer running Windows XP service pack 2 or later, Windows Vista, or Windows 7.

Seasoft V2 – Sea-Bird’s complete Windows software package, which includes software for communication, real-time data acquisition, and data analysis and display. Seasoft V2 includes **Seaterm**, SeatermAF, Seasave, SBE Data Processing, and Plot39.

Seaterm - Sea-Bird’s Windows software used to communicate with the SBE 44 through the SIM.

Sensor – See Serial Instrument.

Serial Instrument – An instrument connected serially to the SBE 44. Typical instruments with standard serial interfaces that are used with the SBE 44 include current meters and Doppler profilers.

SIM - Surface Inductive Modem PCB, used to interface between the computer serial port and SBE 44s or other IM instruments. Either an IMM or SIM is required to interface with the SBE 44.

Super O-Lube – Silicone lubricant used to lubricate O-rings and O-ring mating surfaces. Super O-Lube can be ordered from Sea-Bird, but should also be available locally from distributors. Super O-Lube is manufactured by Parker Hannifin (www.parker.com/ead/cm2.asp?cmid=3956).

UIM - SBE 44 Underwater Inductive Modem.

Appendix I: Functional Description

Sea-Bird's Inductive Modem telemetry system uses a DPSK data transmission method that overcomes most of the disadvantages of Frequency Shift Keyed (FSK) transmission, resulting in superior transmission efficiency and much lower error rates. The Sea-Bird system uses a carrier frequency of 4800 Hz, permitting four cycles of carrier frequency during the time allotted to each data bit (i.e., 1200 baud).

The encoding scheme is straightforward: if the next bit is a one, the phase of the carrier is inverted (shifted 180 degrees); if the next bit is a zero, the carrier phase does not change. With DPSK, both the modulation and demodulation hardware are extremely simple. Modulation requires only an OR gate and flip-flop, and demodulation is inherently coherent (bit energy is averaged rather than spot-sampled) using minimal hard logic, a shift register implementing a one-bit delay being the principle component. Further advantages are that the transmission of all zeros creates a single coherent frequency (4800 Hz) that is readily detected in IM instruments as the *wake up* signal, and that - unlike FSK - the connection polarity of the transformers used for coupling does not matter.

Appendix II: Electronics Disassembly/Reassembly

Disassembly

1. Remove the modem end cap and battery pack following instructions in *Installing Battery Pack* in *Section 3: Preparing SBE 44 for Deployment*.
2. The electronics are on a sandwich of three rectangular PCBs. These PCBs are assembled to a bulkhead that can be seen at the bottom of the battery compartment. To remove the PCB assembly:
 - A. Use a long screwdriver (#1 screwdriver) to remove the Phillips-head screw at the bottom of the battery compartment. The Phillips-head screw is a 198mm (7.8 in.) threaded rod with Phillips-head.
 - B. Pull out the PCB assembly using the PVC pylon post. The assembly will pull away from the 10-position edge connector used to connect to the sensors.

Reassembly

1. Sight down into the SBE 44 housing to find the hole into which the Phillips-head screw threads. The hole is at the bottom of the housing, next to the edge connector. The small-diameter brass sleeve between two of the PCBs guides the screw into the hole. Align this sleeve with the hole.
2. Guide the PCB assembly into the housing and push the assembly until the edge connector is fully inserted. A gentle resistance can be felt during the last 3 mm ($1/8$ inch) of insertion as the PCB assembly mates to the edge connector.
3. Drop the Phillips-head screw into the hole and tighten gently.
4. If it is difficult to align the cards, obtain a 305mm (12 in.) length of 6-32 threaded rod.
 - A. Thread the end of this rod into the hole at the bottom of the housing (next to the edge connector).
 - B. Slide the PCB assembly's small diameter brass sleeve down the rod. The rod will help guide the assembly into the proper position.
 - C. Push the assembly until the edge connector is fully inserted. After the PCB assembly has been fully inserted, remove the rod.
 - D. Drop the Phillips-head screw into the hole and tighten gently.
5. Reinstall the battery pack and modem end cap following instructions in *Installing Battery Pack* in *Section 3: Preparing SBE 44 for Deployment*.

Note:

If the rod will not tighten, the PCBs have not fully mated or are mated in reverse.

Note:

Before delivery, a desiccant package is inserted in the housing and the electronics chamber is filled with dry Argon gas. These measures help prevent condensation. To ensure proper functioning:

1. Install a new desiccant bag each time you open the electronics chamber. If a new bag is not available, see *Application Note 71: Desiccant Use and Regeneration (drying)*.
2. If possible, dry gas backfill each time you open the housing. If you cannot, wait at least 24 hours before redeploying, to allow the desiccant to remove any moisture from the housing.

Opening the battery compartment does not affect desiccation of the electronics.

Appendix III: Command Summary

Note:

- See *Command Descriptions* in *Section 4: Deploying and Operating SBE 44* for detailed information and examples.
- If using the SBE 44 with an IMM, see the IMM manual for IMM command descriptions.

FUNCTION	CATEGORY	COMMAND	DESCRIPTION
SIM Commands	Power-On	PwrOn	Send wakeup tone to all IMs.
		PwrOff	Send power off command to all IMs, turn off transmitter. IMs enter quiescent (sleep) state. Any data in SBE 44 buffer is erased.
		AutoPwrOn=x	x=Y (default): Send PwrOn to IMs when power applied to SIM. This wakes up all IMs on line. x=N : Do not send PwrOn to IMs when power applied to SIM.
	Status	DS	Display SIM firmware version and status.
	Communications	Baud=x	x = baud rate between SIM and computer/controller (1200, 2400, 4800, or 9600). Default 9600.
		DataNNMax=x	x = timeout (0-32767 msec) that applies to Dataii only. If no reply received within DataNNMax , control returned to computer and other commands can be sent. Default 1000 msec.
		RelayMax=x	x = timeout (0-3276 sec) that applies to all other commands. If no reply received within RelayMax , control returned to computer and other commands can be sent. Default 20 sec.
		BinaryGap=x	x = termination timeout (0 – 65535 msec) that applies to commands requesting binary response (BiCmdString). Gap of BinaryGap since last byte received acts as termination character. Bytes sent after gap are ignored; control is returned to computer and other commands can be sent. Default 1000 msec. Must set BinaryGap < !iiRTermMax .
		EchoOn	Echo characters received from computer (default).
		EchoOff	Do not echo characters.

FUNCTION	CATEGORY	COMMAND	DESCRIPTION
ID Commands	SBE 44 ID Only 1 SBE 44 can be on line when sending these commands.	ID?	Display SBE 44 ID (ID=ii, where ii=0-99)
		*ID=ii If more than 1 SBE 44 on line when setting ID, all SBE 44s will have same ID.	Set SBE 44 ID to ii, where ii=0-99. Command must be sent twice, because verification requested.
SBE 44 and Sensor Commands	SBE 44 Status Commands preceded by !ii (ii=SBE 44 ID).	!iiDS	Display firmware version and system setup information.
		!ii*EETest	Test SBE 44's EEPROM as a troubleshooting tool, and reset all parameters to default values.
	SBE 44 General Setup Commands preceded by !ii (ii=SBE 44 ID).	!iiBaud=x	x= baud rate for serial communication between SBE 44 and sensor (300, 600, 1200, 2400, 4800, 9600, or 19200). Default 9600.
		!iiRelayTermChar=x	x= decimal value (0-255) of command termination character to specify what is appended to sensor character string for Send Command String and Get Data commands. If x=CRLF (default), appends carriage return and line feed. If x=NONE, appends nothing.
		!iiTermChar=x	x= decimal value (11-122) of sensor reply termination character. If SBE 44 receives termination character, ignores any additional characters. If x=NONE, termination character checking disabled. Default 62 (>).
		!iiTimeOut=x	x= SBE 44 timeout (30-1800 sec). If no commands or replies received for x, SBE 44 enters quiescent (sleep) state. Any data in SBE 44 buffer erased. Default 120 sec.

FUNCTION	CATEGORY	COMMAND	DESCRIPTION
SBE 44 and Sensor Commands (continued)	Relay Commands: Relay Setup Commands preceded by !ii (ii=SBE 44 ID).	!iiRStartWait=x	x= command transmission delay after setting control line or switched power (0-32767 msec). Default 0 msec.
		!iiRTermMax=x	x= termination timeout for sensor reply (0-32767 msec). Gap of !iiRTermMax after 2 characters received acts as termination character. Default 1000 msec.
		!iiRTotalMax=x	x= total time allowed for sensor reply to (0-600 sec). Default 15 sec.
	Relay Commands: Send Command String Command preceded by #ii (ii=SBE 44 ID).	#iiCmdString	Command SBE 44 to send character string defined by CmdString to sensor. CmdString can be any command recognized by sensor. SBE 44 can append carriage return and line feed or character to string (see !iiRelayTermChar=). Response sent through SBE 44 to SIM and computer/controller.
		BiiCmdString	Command SBE 44 to send character string defined by CmdString to sensor. CmdString can be any character string recognized by sensor that requests a binary response. Binary response is sent through SBE 44 to SIM and computer/controller; any termination characters are ignored.
	Relay Commands: Send Character Commands preceded by !ii (ii=SBE 44 ID). !iiRelayTermChar does not apply to these commands.	!iiSendCharW=x	Command SBE 44 to send character defined by decimal value x to sensor. Character can be any command recognized by sensor. Response sent through SBE 44 to SIM and computer/controller.
		!iiSendChar=x	Command SBE 44 to send character defined by decimal value x to sensor. Character can be any command recognized by sensor. SBE 44 does not accept any response from sensor.
	Relay Commands: Send Break Commands preceded by !ii (ii=SBE 44 ID). !iiRelayTermChar does not apply to these commands.	!iiBreakLen=x	x= break character length (0-32750 msec). Default 1000 msec.
		!iiSendBreak	Command SBE 44 to send break character (defined by !iiBreakLen=) to sensor. Response sent through SBE 44 to SIM and computer/controller.

FUNCTION	CATEGORY	COMMAND	DESCRIPTION
SBE 44 and Sensor Commands (continued)	<p>Get Data Commands: <i>Setup</i> Commands preceded by !ii (ii=SBE 44 ID).</p> <p>Set up controls and timeouts for Get Data (GData or !iiGData) commands. Get Data commands cause sensor command pre-defined by !iiGDataStr=S to be sent to sensor. Sensor reply held in SBE 44 buffer.</p>	!iiGStartWait=x	x= command transmission delay after setting control line or switched power (0-32767 msec). Default 0 msec.
		!iiGTermMax=x	x= termination timeout for sensor reply (0-32767 msec). Gap of !iiGTermMax after 2 characters received acts as termination character. Default 1000 msec.
		!iiGTotalMax=x	x= total time allowed for sensor reply (0-600 sec). Default 30 sec.
		!iiIncGDataDelay=x	x=Y: In Dataii reply, include number of 0.1-sec ticks received while waiting for GData or !iiGData reply. x=N: Do not include number of ticks.
		!iiGDataStr=S	S= character string sent to sensor in response to GData or !iiGData . Character string can be any command recognized by sensor. SBE 44 can append carriage return and line feed or character to string (see !iiRelayTermChar).
	<p>Get Data Commands <i>Get Data</i></p>	<p>GData Global command to all SBE 44s.</p>	Command all SBE 44s to get data from sensors. Each SBE 44 holds data in buffer until receiving Dataii .
		<p>!iiGData Command to SBE 44 with ID=ii (ii=0-99).</p>	Command SBE 44 to get data from sensor. SBE 44 holds data in buffer until receiving Dataii .
		<p>Dataii Command to SBE 44 with ID=ii (0-99).</p>	Get data obtained with GData or !iiGData from buffer of SBE 44 with ID=ii. Data sent to SIM and computer/controller.
	<p>Switched Power Setup Commands preceded by !ii (ii=SBE 44 ID).</p> <p>Set up controls for optional switched power operation (pin 4 on connector).</p>	!iiSwPwrOn	Switch power on to sensor now. Power remains on while SBE 44 awake. When SBE 44 enters quiescent (sleep) state, power to sensor switches off.
		!iiSwPwrOff	Switch power off to sensor now.
		!iiAutoSwPwrPOn=x	x=Y: Switch power on to sensor each time SBE 44 powers on. When SBE 44 enters quiescent (sleep) state, power to sensor switches off. x=N (default): Do not switch power on to sensor when SBE 44 powers on.
		!iiAutoSwPwrGData=x	x=Y: Switch power on to sensor before sending Get Data command string (!iiGDataStr) to sensor. Power to sensor switches off when sensor response ends. x=N (default): Do not switch power on to sensor before sending Get Data command string.
		!iiAutoSwPwrRelay=x	x=Y: Switch power on to sensor before sending Relay command (#iiCmdString , !iiSendCharW=x , !iiSendChar=x , or !iiSendBreak) to sensor. Power to sensor switches off when sensor response ends. x=N (default): Do not switch power on to sensor before sending Relay command string.

FUNCTION	CATEGORY	COMMAND	DESCRIPTION
SBE 44 and Sensor Commands (continued)	Control Line Setup All commands preceded by !ii (ii=SBE 44 ID). Set up controls for optional control line operation (pin 5 on connector).	!iiCntlOn	Enable control line to sensor now. Control line remains enabled while SBE 44 awake. When SBE 44 enters quiescent (sleep) state, control line disabled.
		!iiCntlOff	Disable control line to sensor now.
		!iiAutoCntlPOn=x	x=Y : Enable control line to sensor each time SBE 44 powers on. When SBE 44 enters quiescent (sleep) state, control line disabled. x=N : Do not enable control line to sensor when SBE 44 powers on.
		!iiAutoCntlGData=x	x=Y : Enable control line to sensor before sending Get Data command string (!iiGDataStr) to sensor. Control line disabled when sensor response ends. x=N : Do not enable control line to sensor before sending Get Data command string.
	!iiAutoCntlRelay=x	x=Y : Enable control line to sensor before sending Relay command (#iiCmdString , !iiSendCharW= , !iiSendChar= , or !iiSendBreak) to sensor. Control line disabled when sensor response ends. x=N : Do not enable control line to sensor before sending Relay command string.	
	Surface Tone Detect Commands	!iiPOnTone=x	x=Y : Enable surface tone detect. After powering on, SBE 44 waits 2.5 sec, enables its transmitter, transmits 4800 Hz tone for 2.5 sec, and then turns off its transmitter. x=N : Do not enable surface tone detect. Default.

Appendix IV: SIM Hookup and Configuration

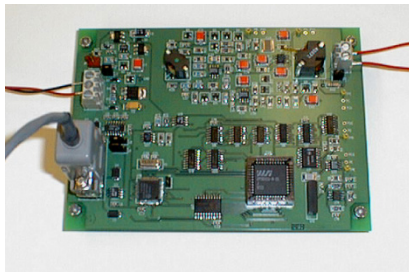
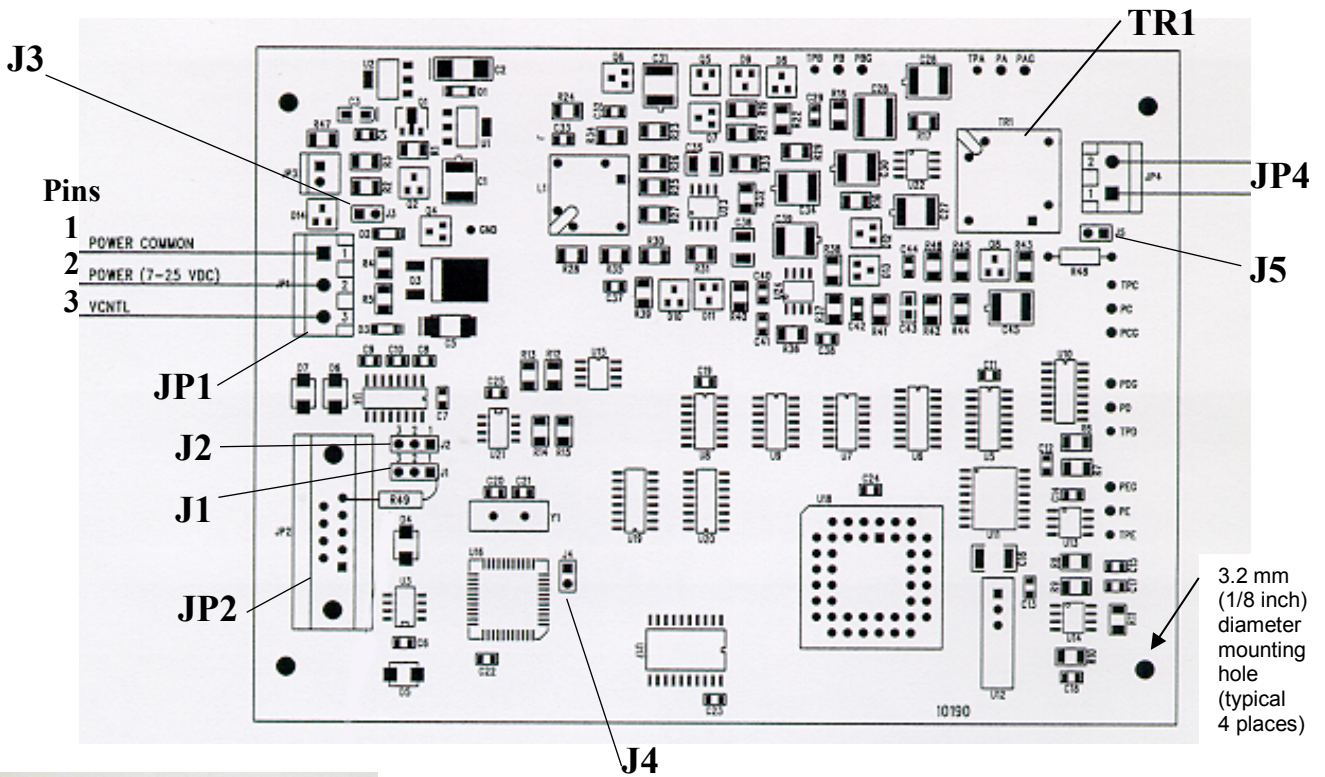

Photo shows SIM-Direct for use without Inductive Cable Coupler. SIM-Coupled for use with Inductive Cable Coupler is similar, but does not include TR1.

Dimensions:

PCB: 109 mm x 147.5 mm (4 1/4 x 5 3/4 inches)

Mounting holes: 90.5 mm x 138.1 mm (3 9/16 x 5 7/16 inches)

Power Connection

The SIM can be configured to power up in either of the following two modes:

- **Normal Power Switching (factory setting)** – The SIM runs when power is applied. Set up the SIM as follows:
 1. Connect Power Common to JP1 pin 1.
 2. Connect 7-25 VDC to JP1 pin 2.
 3. Verify there is no connection to JP1 pin 3.
 4. Verify jumper is across J3.
- **Logic Level Controlled Power Switching** – Power is always applied to JP1, pins 1 and 2. Voltage applied to JP1 pin 3 (VCNTL) switches power to the SIM. Set up the SIM as follows:
 1. Connect Power Common to JP1 pin 1.
 2. Connect 7-25 VDC to JP1 pin 2.
 3. Remove jumper on J3.

Note:

If VCNTL < 1 volt, SIM is Off (consuming < 100 microAmps).
If VCNTL > 2 volts, SIM is On.

Interface Option Connection (J1, J2, and J4) and I/O Connector Wiring (JP2)

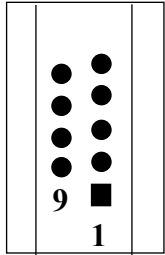
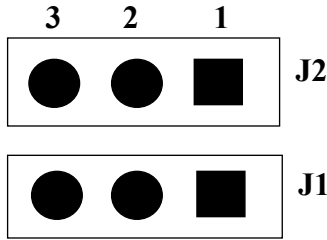

The SIM can be configured to accept RS-232 or RS-485:

- **RS-232 (factory setting)**
 1. Verify jumper is on **J1** pins 2 and 3.
 2. Verify jumper is on **J2** pins 2 and 3.
 3. Remove jumper on **J4**.
- **RS-485**
 1. Install jumper on **J1** pins 1 and 2.
 2. Install jumper on **J2** pins 1 and 2.
 3. Install jumper on **J4**.

Connect wires to **JP2** as follows:

- **RS-232**
 1. **Pin 2** – RS-232 transmit from SIM to computer
 2. **Pin 3** – RS-232 transmit from computer to SIM
 3. **Pin 5** – Power Common
- **RS-485**
 1. **Pin 4** – RS-485 ‘A’
 2. **Pin 5** – Power Common
 3. **Pin 6** – RS-485 ‘B’

Notes on RS-485 Interface

- This implementation of RS-485 allows for extended cable lengths, but does not include the ability to address multiple SIMs online. The RS-485 interface is described as *Simple*, because it does not allow you to communicate with more than one SIM on a single line.
- The RS-485 interface is half-duplex. Do not type or send a command while the SIM is transmitting data or responding to a command, or you will disrupt both sent and received data.
- This SIM can transmit data at 38400 baud over up to 1200 meters of twisted pair wire cable, 26 AWG or smaller gauge (larger diameter); data transmission at long distances is highly application specific, and requires high-quality cable and appropriate termination.

Inductive Mooring Cable Connection (JP4)

Note:

ICC version 4 may have 3 wires in the cable. If you ordered the ICC with a pigtail termination, solder the white and white/black wires together and attach to 1 terminal of JP4. Attach the white/red wire to the other terminal.

- **SBE 44 installed with Inductive Cable Coupler (ICC) -**
Connect wires from the ICC to JP4 on SIM-Coupled.
- **SBE 44 installed without Inductive Cable Coupler -**
Connect wires from the mooring cable and seawater ground to JP4 on SIM-Direct.

Normal Deployed Operation (J5)

Note:

If more than one IM instrument is on-line when you set the ID, all IM instruments will be set to the same ID. The inductive modem receivers in IM instruments are very sensitive; two IM instruments that are side-by-side will take the same ID, even if one of them is not on the IM loop. **Therefore, separate IM instruments by at least 2 meters when setting IDs.**

- **Normal Deployed Operation** – Ensure jumper on J5 is installed.
- **Instrument Setup and Lab Testing** - Remove jumper on J5. Removing the jumper on J5 inserts a 1K resistor in series with the inductive loop, reducing the signal amplitude. This prevents the SBE 44s in close proximity from responding to commands, which is especially important when sending the *ID= command.

Tone Detect Board Connection

For SIM-Direct:
Connect to PA and PAG

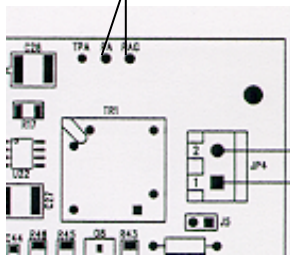

For SIM-Coupled:
Connect to JP4

A surface *Tone Detect* board is used for specialized applications. See *Appendix VI: Using SBE 44 with Tone Detect Board* for a detailed description.

- **SBE 44 installed without Inductive Cable Coupler (using SIM-Direct)**
– Connect wires from the *Tone Detect* board to PA and PAG.
- **SBE 44 installed with Inductive Cable Coupler (using SIM-Coupled)**
– Connect wires from the *Tone Detect* board to JP4, or solder wires to wires connecting to JP4.

Appendix V: SBE 44 Interface PCB Configuration

This appendix describes the jumper configuration on the SBE 44's **Interface PCB** (labeled 10219). See *Appendix II: Electronics Disassembly/Reassembly* to access the Interface PCB.

Standard Setup (no optional control signal or optional switched power out)

For standard configuration, Sea-Bird recommends that you remove the J1 and J2 jumpers.

Optional Control Signal (jumper J1 on Interface PCB)

The optional control signal (pin 5 on bulkhead connector) can be configured in either of the following modes:

- **5 Volt logic** – jumper J1 pins 1 and 2
- **Open Collector logic** – jumper J1 pins 2 and 3

Optional Switched Power Out (jumper J2 on Interface PCB)

The optional switched power out (pin 4 on bulkhead connector) can be configured to power the serial instrument in either of the following modes:

- Power serial instrument **from SBE 44 battery pack or external voltage** (draw power from whichever voltage source is higher) – jumper J2 **pins 1 and 2**
- Power serial instrument **from external voltage only** (regardless of which voltage source is higher) – jumper J2 **pins 2 and 3**

Note:

External voltage (optional) is supplied to the SBE 44 through pin 6 on the bulkhead connector.

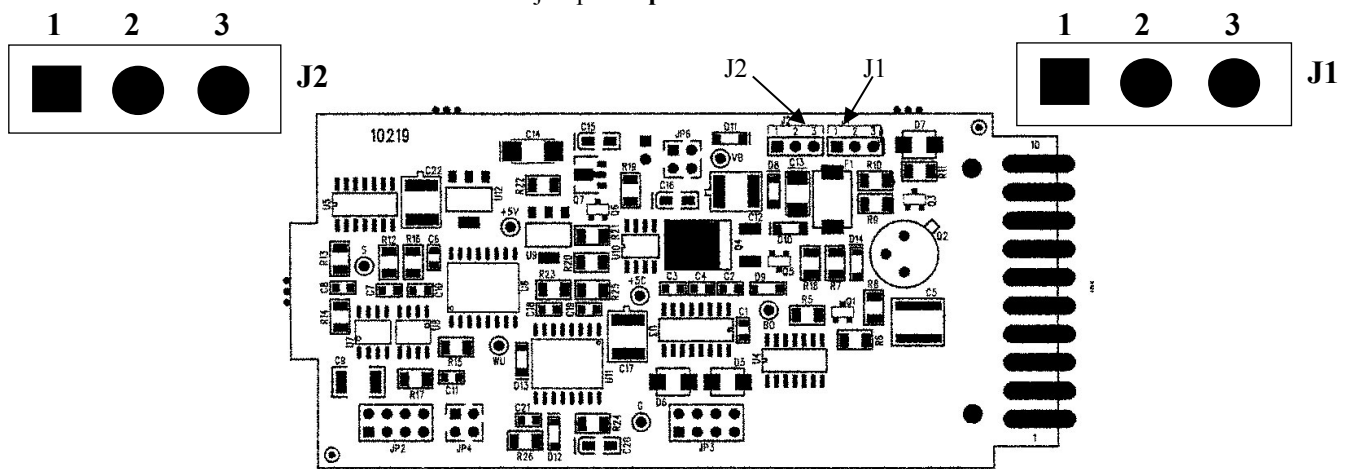

Appendix VI: Using SBE 44 with Tone Detect Board

A surface *Tone Detect* board can be supplied by Sea-Bird. Typically, a SBE 44 system with a *Tone Detect* board is used when the serial instrument needs to indicate that it has completed sampling and is ready to transmit data. System schematics are shown below:

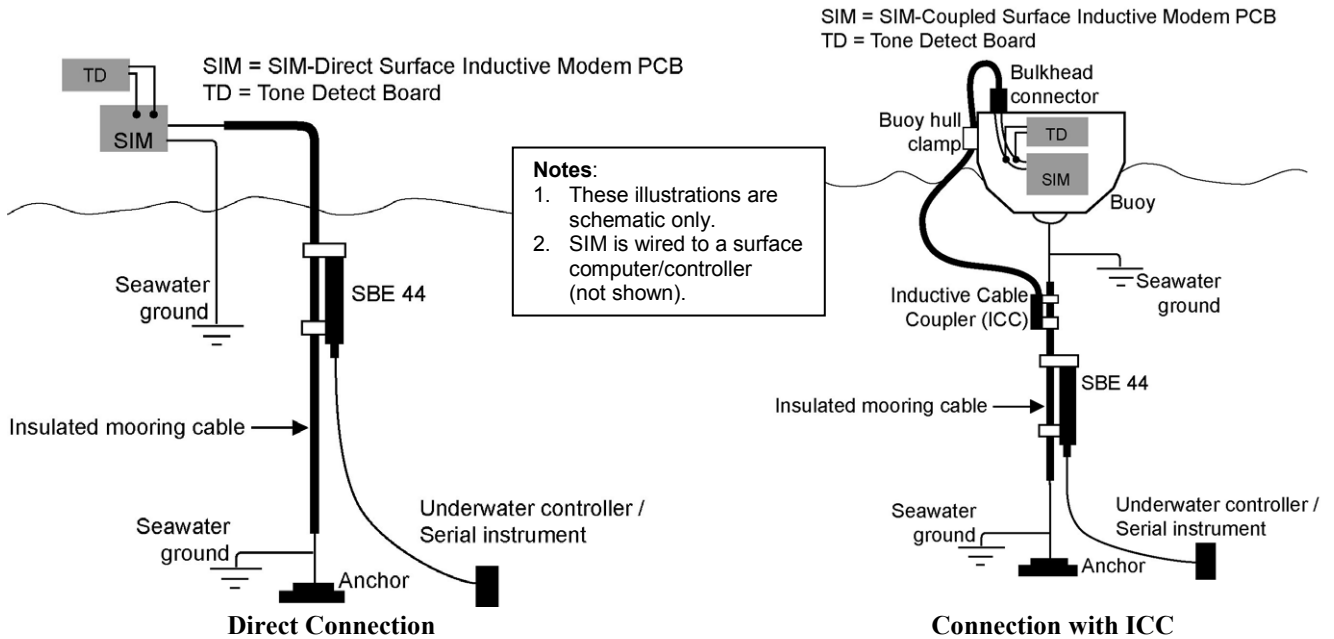

Wiring

- **Tone Detect Board JP1**
Pin 1: connect to SIM-Coupled JP4 pin 1 or SIM-Direct PA
Pin 2: connect to SIM-Coupled JP4 pin 2 or SIM-Direct PAG
- **Tone Detect Board JP4**
Pin 1: ground
Pin 2: tone detect output, PNP transistor emitter is pulled to ground when tone is detected
pin 3: 6 – 20 VDC in (150 microAmps when waiting for tone)

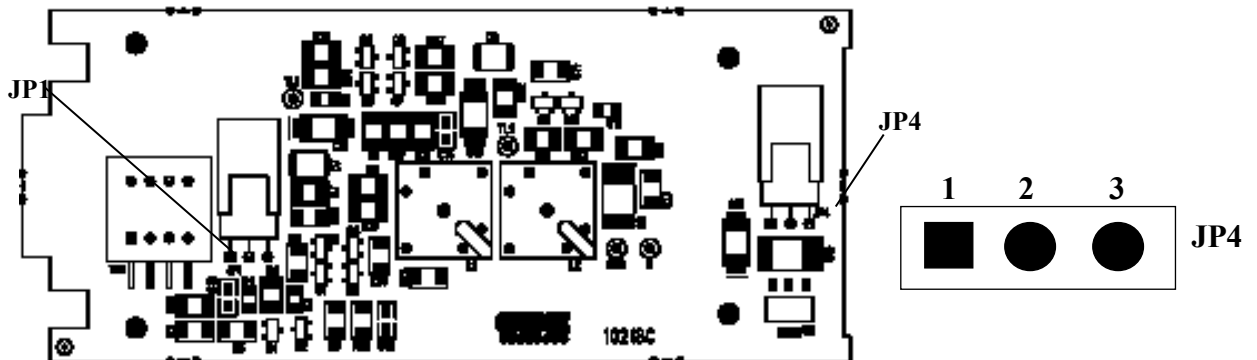
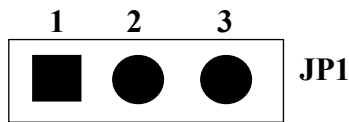

The impedance of the inductive link must be 500 ohms or less at 4800 Hz for reliable operation. A mooring cable on a spool may have considerable impedance, and may need to be unspooled before using the inductive link.

The inductance of a spooled cable can be estimated by:

$$L \text{ (Henries)} = 1.0 \times 10^{-6} * 0.8 * a^2 * n^2 / (6 * a + 9 * b + 10 * c)$$

where

a = average radius of windings (inches)

b = length of the coil (inches)

c = difference between outer and inner radii of coil (inches)

n = number of windings on spool

The impedance at 4800 Hz is:

$$\text{Impedance (ohms)} = 1 / (2.0 * \pi * 4800 * L)$$

where

L = inductance (Henries)

Operation

To use the tone detect:

- Set up your underwater controller/serial instrument to pull the detect line low on the SBE 44 when it has completed sampling.
- Set up your surface computer/controller to send the appropriate commands to get the data from the underwater controller/serial instrument, when it is signaled by the surface *Tone Detect* board.
- Set **!iiPOnTone=Y** to enable the tone detect in the SBE 44.

Note:

Transmission of the 4800 Hz tone by the SBE 44 *wakes up* all other inductive modem instruments (such as other 44s as well as 37-IM, 37-IMP, 37-IMP-IDO, 39-IM, 16*plus*-IM, 16*plus*-IM V2, UIMM) on the mooring cable. These other instruments will draw their communications current (varies; see appropriate instrument manual) from their batteries while awake. They will go back to sleep after 2 minutes, or sooner if you send the **PwrOff** command. If you will be using the tone detect frequently, you should consider this effect on the power budget for the other IM instruments on the mooring.

When the underwater controller/serial instrument has completed sampling, the system responds as follows:

1. The underwater controller/serial instrument pulls the detect line low on the SBE 44, powering the SBE 44 on.
2. The SBE 44 waits 2.5 sec, enables its transmitter, transmits a 4800 Hz tone for 2.5 sec, and then turns off its transmitter.
3. The 4800 Hz tone is received by the surface *Tone Detect* board, which then signals the surface computer/controller.
4. The surface computer/controller sends the appropriate commands through the SIM to the SBE 44 to get the data from the underwater controller/serial instrument.

Shown below are two example command sets for a tone detect board system. The SBE 44's response to each command is not shown in the examples.

Example: System with Tone Detect Board and Multiple Inductive Modem Instruments (user input in bold)

Assume the following system: An underwater controller/sensor (call this UC) is sampling, and needs to upload the last sample data through the SBE 44 after each sample is taken. UC is programmed to pull detect line low on SBE 44 when sampling is complete. UC command set includes **SL** (send last data sample taken by UC).

Define SIM operation for entire system, and then verify SIM setup.

S>**AUTOPWRON=N** (do not automatically send **PwrOn** to SBE 44s when power applied to SIM)
 S>**RELAYMAX=20** (set total time allowed for sensor reply in SIM to 20 sec)
 S>**ECHOOFF** (do not echo characters to surface controller)
 S>**DS** (verify SIM setup)

With (only) SBE 44 01 on-line: Send wakeup tone to SBE 44, and display SBE 44 ID to verify ID. Set baud, termination characters, and timeouts, and enable the surface tone detect. Verify SBE 44 setup, and send power-off command.

S>**PWRON** (wake up SBE 44; wait at least 10 sec before proceeding to ensure SBE 44 is awake)
 S>**ID?** (verify SBE 44 ID)
 S>**!01BAUD=9600** (set baud between SBE 44 and underwater controller/sensor to 9600)
 S>**!01TIMEOUT=120** (set SBE 44 main timeout to 120 sec = 2 minutes)
 S>**!01RELAYTERMCHAR=crlf** (append carriage return and line feed to commands relayed to underwater controller/sensor)
 S>**!01TERMCHAR=x** (application dependent reply termination character)
 S>**!01RSTARTWAIT=x** (application dependent)
 S>**!01RTERMMAX=2000** (set sensor reply gap timeout in SBE 44 to 2000 msec = 2 sec)
 S>**!01RTOTALMAX=20** (set total time allowed for sensor reply in SBE 44 to 20 sec)
 S>**!01PONTONE=Y** (enable surface tone detect)
 S>**!01DS** (verify SBE 44 setup)
 S>**PWROFF** (place SBE 44 in sleep state)

Disconnect SBE 44 01 from SIM.

For each SBE 44 that will be incorporated in system: connect SBE 44 to SIM, and repeat **PwrOn** through **PwrOff** using appropriate SBE 44 ID.

Deploy system. When UC has completed sampling and is ready to transmit data, it pulls detect line low on SBE 44, powering SBE 44. SBE 44 waits 2.5 sec, enables its transmitter, transmits a 4800 Hz tone for 2.5 sec, and then turns off its transmitter. Tone is received by surface *Tone Detect* board, which then signals SC to apply power to SIM. Wait at least 5 sec to ensure SBE 44 is listening for commands.

S>**#01SL** (SC sends command to send last sample taken by UC)
 S>**PWROFF** (SC sends command to power down all SBE 44s)
 (SC powers down SIM and SC)

Example: System with Tone Detect Board and 1 Instrument with Binary Data (user input in bold)

Assume the following system: An underwater controller/sensor (call this UC) is sampling, and needs to upload binary data through the SBE 44 after each sampling session is complete. UC is programmed to pull detect line low on SBE 44 when sampling is complete. UC command set includes **status** (transmit status of instrument, including number of bytes in memory) and **sendb,e** (upload data in binary, from byte **b** to byte **e**). Surface computer/controller (call this SC) is programmed to interpret UC status response, and then send appropriate command(s) to upload data, limiting data transfer to 30,000 bytes at a time because of SBE 44's 30 Kbyte buffer.

Note: The SBE 44's binary data capability is intended for use on a system with only one inductive modem instrument online. A binary data reply *could* inadvertently include the equivalent of a valid command for other inductive modem instruments on line, causing other instruments to respond and thereby corrupting the data stream. **Sea-Bird strongly recommends that you do not use the binary data capability with multiple inductive modem instruments online.**

Define SIM operation, and then verify SIM setup.

```
S>AUTOPWRON=N      (do not automatically send PwrOn to SBE 44s when power applied to SIM)
S>RELAYMAX=600     (set total time allowed for sensor reply in SIM to 600 sec = 10 minutes)
S>BINARYGAP=1000   (set sensor binary reply gap detect timeout in SIM to 1000 millisecc = 1 sec)
S>ECHOOFF         (do not echo characters to surface controller)
S>DS              (verify SIM setup)
```

With (only) SBE 44 01 on-line: Send wakeup tone to SBE 44, and display SBE 44 ID to verify ID. Set baud, termination characters, and timeouts, and enable the surface tone detect. Verify SBE 44 setup, and send power-off command.

```
S>PWRON           (wake up SBE 44; wait at least 10 sec before proceeding to ensure SBE 44 is awake)
S>ID?            (verify SBE 44 ID)
S>!01BAUD=9600    (set baud between SBE 44 and underwater controller/sensor to 9600)
S>!01TIMEOUT=120 (set SBE 44 main timeout to 120 sec = 2 minutes)
S>!01RELAYTERMCHAR=cr lf (append carriage return and line feed to commands relayed to underwater controller/sensor)
S>!01TERMCHAR=x  (application dependent reply termination character; not applicable to binary reply)
S>!01RSTARTWAIT=x (application dependent)
S>!01RTERM MAX=2000 (set sensor reply gap timeout in SBE 44 to 2000 msec = 2 sec)
S>!01RTOTALMAX=600 (set total time allowed for sensor reply in SBE 44 to 600 sec = 10 minutes)
S>!01PONTONE=Y   (enable surface tone detect)
S>!01DS         (verify SBE 44 setup)
S>PWROFF        (place SBE 44 in sleep state)
Disconnect SBE 44 01 from SIM.
```

Deploy system. When UC has completed sampling and is ready to transmit data, it pulls detect line low on SBE 44, powering SBE 44. SBE 44 waits 2.5 sec, enables its transmitter, transmits a 4800 Hz tone for 2.5 sec, and then turns off its transmitter. Tone is received by surface *Tone Detect* board, which then signals SC to apply power to SIM. Wait at least 5 sec to ensure SBE 44 is listening for commands.

```
S>#01status      (SC sends status command to UC connected to SBE 44 01; assume status command shows there are 45,000 bytes)
S>b01send1,30000 (SC sends command to upload bytes 1 - 30,000 in binary to UC connected to SBE 44 01)
S>b01send30001,45000 (SC sends command to upload bytes 30,001 - 45,000 in binary to UC connected to SBE 44 01)
S>PWROFF        (SC sends command to power down all SBE 44s)
                  (SC powers down SIM and SC)
```

Appendix VII: Character Map and Values

The character map is used to set the sensor reply termination character (**!iiTermChar**), as described in *Section 4: Deploying and Operating SBE 44*.

Screen Codes						Screen Codes (cont.)					
Dec.	Hex	Sym.	Dec.	Hex	Sym.	Dec.	Hex	Sym.	Dec.	Hex	Sym.
0	00		32	20		64	40	@	96	60	`
1	01	☺	33	21	!	65	41	A	97	61	a
2	02	☹	34	22	"	66	42	B	98	62	b
3	03	♥	35	23	#	67	43	C	99	63	c
4	04	♦	36	24	\$	68	44	D	100	64	d
5	05	♣	37	25	%	69	45	E	101	65	e
6	06	♠	38	26	&	70	46	F	102	66	f
7	07	•	39	27	'	71	47	G	103	67	g
8	08	■	40	28	(72	48	H	104	68	h
9	09	○	41	29)	73	49	I	105	69	i
10	0A	■	42	2A	*	74	4A	J	106	6A	j
11	0B	♠	43	2B	+	75	4B	K	107	6B	k
12	0C	♠	44	2C	,	76	4C	L	108	6C	l
13	0D	♠	45	2D	-	77	4D	M	109	6D	m
14	0E	♠	46	2E	.	78	4E	N	110	6E	n
15	0F	✱	47	2F	/	79	4F	O	111	6F	o
16	10	▶	48	30	0	80	50	P	112	70	p
17	11	◀	49	31	1	81	51	Q	113	71	q
18	12	‡	50	32	2	82	52	R	114	72	r
19	13	!!!	51	33	3	83	53	S	115	73	s
20	14	¶	52	34	4	84	54	T	116	74	t
21	15	§	53	35	5	85	55	U	117	75	u
22	16	■	54	36	6	86	56	V	118	76	v
23	17	‡	55	37	7	87	57	W	119	77	w
24	18	†	56	38	8	88	58	X	120	78	x
25	19	‡	57	39	9	89	59	Y	121	79	y
26	1A	→	58	3A	:	90	5A	Z	122	7A	z
27	1B	←	59	3B	;	91	5B	[123	7B	{
28	1C	┌	60	3C	<	92	5C	\	124	7C	
29	1D	++	61	3D	=	93	5D]	125	7D	}
30	1E	▲	62	3E	>	94	5E	ˆ	126	7E	~
31	1F	▼	63	3F	?	95	5F	—	127	7F	⌘

Appendix VIII: Replacement Parts

Part Number	Part	Application Description	Quantity in SBE 44
50441	AA Saft Lithium cell set (12)	Power SBE 44.	
801797	Cell holder for SBE 44	Holds AA cells.	1
171887	9-pin DB-9P to 9-pin DB-9S I/O cable, 3 m (10 ft) long	From SIM to computer	-
801583	10-pin DF11 to 9-pin DB-9S and battery snap	From IMM to computer and power supply	-
171888	25-pin DB-25S to 9-pin DB-9P cable adapter	For use with computer with DB-25 connector	-
801434	6-pin AG-206 to 9-pin DB-9S serial test cable, 2.4 m (8 ft) long	Connects SBE 44 connector to computer for lab testing	-
17047.1	6-pin AG-206 dummy plug with locking sleeve	For storage	-
17043	Locking sleeve for AG connector	Locks cable or dummy plug in place	
801450	6-pin (wet-pluggable) MCIL-6FS to 9-pin DB-9S serial test cable, 2.4 m (8 ft) long	Connects SBE 44 connector to computer for lab testing	
171498.1	6-pin MCDC-6F dummy plug with locking sleeve	For storage	
171192	Locking sleeve	Locks cable or dummy plug in place	
41247	Surface <i>Tone Detect</i> board	For specialized applications	-
60050	Spare hardware/ O-ring kit	Assorted hardware and O-rings, including: <ul style="list-style-type: none"> • 30900 Bolt, 1/4-20 x 2" hex head, titanium (secures mounting clamp) • 30633 Washer, 1/4" split ring lock, titanium (for 30900) • 30634 Washer 1/4" flat, titanium (for 30900) • 31019 O-ring 2-008 N674-70 (for 30900) • 30857 Parker 2-033E515-80 O-ring (modem end cap and connector end cap o-ring) • 30859 Machine screw, 8-32 x 3/8" FH, titanium (secures housing to end caps) • 31749 Hex key, 7/64 inch, long arm (secures battery pack in housing with captured screw) • 31322 O-ring 2-130 N674-70 (for grooves on side of battery pack) • 30858 O-ring 2-133 N674-70 (for battery pack cover plate) 	-

Appendix IX: Manual Revision History

Manual Version	Date	Description
005	12/99	<ul style="list-style-type: none"> Rewrite manual for product release (initial release of production units).
006	08/00	<ul style="list-style-type: none"> Add new commands for Firmware 1.5: RelayTermChar, SendChar, and SendCharw. Add command range information. Replace DOS TERM37 with Windows Seaterm.
007	03/01	<ul style="list-style-type: none"> Add Baud= command for SIM. Correct callout on SIM photo.
008	01/03	<ul style="list-style-type: none"> Test setup procedure: Correct 10-15 VDC power supply for SIM to 7-25 VDC. Add connector diagram for wet-pluggable connector. Add mounting hole diameter for SIM. Add information on how power provided, based on settings on Interface PCB.
009	05/03	<ul style="list-style-type: none"> Add information that characters relayed by serial instrument to 44 must be > 09 decimal (09 Hex) & < 123 decimal (7B Hex); cannot relay @ symbol. Update serial interface cable to 9pin.
010	09/03	<ul style="list-style-type: none"> Firmware 1.6a: Add information on tone detect command and operation.
011	02/04	<ul style="list-style-type: none"> Firmware updates: Biicmdstring to request binary response from serial instrument. BinaryGap= to provide termination timeout for binary response from serial instrument. AutoPwrOn=Y (default) to direct SIM to execute PwrOn when powered up; AutoPwrOn=N to direct SIM to not execute PwrOn when powered up. Add more information on use with a Tone Detect Board. Update cable part numbers.
012	05/04	<ul style="list-style-type: none"> Update photos, system drawings, and text for new ICC design and new SIM terminology (SIM-Direct and SIM-Coupled in place of SMODEM designation used before). Update information on shipping lithium batteries.
013	07/04	<ul style="list-style-type: none"> Add more information on tone detect board regarding wiring of tone detect board, change connection of tone detect board to SIM-Direct PCB, add information on impedance and inductance. Add information that Switched Power Out has a 1.5 Amp thermal fuse in-line (add maximum current consumption information and example power calculation for battery endurance).
014	04/05	<ul style="list-style-type: none"> Firmware rev 1.8a: add 19200 to available bauds between 44 and serial instrument (liiBaud=). Add more information on binary data. In Tone Detect appendix, change binary example to show only 1 instrument on line. Add another example with multiple instruments and a non-binary command. Add more information on use with Tone Detect Board. Update photo of ICC to show connectors as optional. Update battery shipping precautions. Change DataNNMax maximum value to 32767 msec; values not multiples of 50 rounded down. Add references to 39-IM, newest IM instrument. Update SIM operating current from 60 mA to 30 mA..
015	05/06	<ul style="list-style-type: none"> Update recovery warning, adding more detail. Add note to SIM wiring appendix, IM Cable Connection (JP4), regarding number of wires. Update wet-pluggable connector.
016	05/07	<ul style="list-style-type: none"> Add more detail on mating of modem core, description of guide. Add information on troubleshooting communication problems. Add information on BinaryGap in SIM: must be less than RTermMax in SBE 44 for binary reply to work reliably.
017	07/08	<ul style="list-style-type: none"> Update battery installation procedure, specifications, endurance, and shipping instructions for new battery packs (12 AA lithium cells) Update connector maintenance for consistency with application note 57.

Continued on next page

Continued from previous page

018	01/10	<ul style="list-style-type: none"> • Update software name. • List new address. • Add CE mark. • Add information about not having other IM instruments nearby when setting ID. • Add information that serial test cable not optional, included with standard shipment.
019	11/11	<ul style="list-style-type: none"> • Update battery endurance for SBE 44s providing power to the RS-232 sensor, based on Field Service Bulletin 23. • Add IMM information. • Add note about yellow-top battery pack incompatibility with SBE 44. • Add note to not ship spare lithium batteries by commercial aircraft.
020	08/12	<ul style="list-style-type: none"> • Add Certificate of Conformity. • Update Shipping Precautions for latest IATA rules. • Add information on RS-485 communications with SIM. • Remove RS-485 option for IMM.
021	01/13	<ul style="list-style-type: none"> • Update battery shipping restrictions to meet 2013 requirements. • Update software compatibility information.
022	03/14	<ul style="list-style-type: none"> • Update Declaration of Conformity. • Update lithium cell and battery language to conform to latest IATA rules. • Add O-ring maintenance section. • Add caution on using spray can lubricants on MCBH connectors. • Remove <i>standard</i> and <i>optional</i> language referring to connector types. • Correct lithium cell part numbers in Replacement Parts list.

Index

B

Battery pack · 10, 12, 64
 description · 15
 endurance · 12
 installing · 15
 replacing · 50
 shipping precautions · 8

C

CE certification · 3
 Cells
 description · 15
 installing · 15
 replacing · 50
 Character map · 69
 Command summary · 56
 Commands
 communications · 38
 control line setup · 45
 descriptions · 37
 echo · 38
 get data · 32, 43
 ID · 39
 power on/off · 37
 power-on · 37
 relay · 32, 41
 SBE 44 · 39
 SBE 44 general setup · 40
 SBE 44 ID · 39
 SBE 44 status · 39
 send break · 42
 send character · 42
 send command string · 41
 sensor · 39
 status · 38
 Surface Inductive Modem · 37
 surface tone detect · 46
 switched power setup · 44
 timeout · 38
 Communication defaults · 20, 26, 27
 Communications commands · 38
 Connector · 11, 50
 Control signal · 31, 35, 64
 Corrosion precautions · 50

D

Declaration of Conformity · 3
 Deployment · 47
 preparing for · 15
 setup · 46
 Description · 9
 Dimensions · 11

E

Electrical · 11
 Electronics disassembly/reassembly · 55
 External power · *See* Power, external

F

Functional description · 54

G

Glossary · 53

I

ICC · *See* Inductive Cable Coupler
 ID · 19, 25
 setting · 18, 23
 IMM · 23, *See* Inductive Modem Module
 Inductive Cable Coupler · 14, 48
 Inductive Modem Module · 13, 23

M

Maintenance · 50
 Manual revision history · 71
 Modes · *See* Operating modes
 Mooring cable · 14

O

Operating mode examples · 33
 Operating modes · 31
 Operation description · 29
 O-ring
 maintenance · 51

P

Parker Super O-Lube · 53
 Parts
 replacement · 70
 Power
 external · 12, 64
 Power-on commands · 37

Q

Quick start · 6

R

Recovery
 physical handling · 49
 Replacement parts · 70
 Revision history · 71
 RS-485 · 62

S

SBE 44 Interface PCB Configuration · 64
Seasoft · 10, 17
Seaterm · 10, 17, 19, 25
 main screen · 19, 25
 toolbar buttons · 20, 26
Shipping precautions · 8
SIM · *See* Surface Inductive Modem
Software · 10
Software installation · 17
Specifications · 10
Status commands · 38
Super O-Lube · 53
Surface Inductive Modem · 18, 37
 description · 13
 RS-485 · 62
 wiring · 61
Switched power out · 31, 34, 64
System description · 9

T

Terminal program · 10, 17, 19, 25
Testing · 18, 23
Timeout descriptions · 36
Tone detect board · 63, 65
Troubleshooting · 52

U

Unpacking SBE 44 · 7

V

Versions · 71

W

Wiring · 48