

# SBE 55 ECO Water Sampler

---



## User's Manual

Sea-Bird Electronics, Inc.  
13431 NE 20<sup>th</sup> Street  
Bellevue, Washington 98005 USA  
Telephone: 425-643-9866  
Fax: 425-643-9954  
E-mail: seabird@seabird.com  
Website: www.seabird.com

**Manual Version #007, 04/29/13**  
**Firmware Version 1.3 and later**  
**SeatermAF Version 2.1.3 and later**  
**Seasave V7 Version 7.22.5 and later**



# Limited Liability Statement

Extreme care should be exercised when using or servicing this equipment. It should be used or serviced only by personnel with knowledge of and training in the use and maintenance of oceanographic electronic equipment.

SEA-BIRD ELECTRONICS, INC. disclaims all product liability risks arising from the use or servicing of this system. SEA-BIRD ELECTRONICS, INC. has no way of controlling the use of this equipment or of choosing the personnel to operate it, and therefore cannot take steps to comply with laws pertaining to product liability, including laws which impose a duty to warn the user of any dangers involved in operating this equipment. Therefore, acceptance of this system by the customer shall be conclusively deemed to include a covenant by the customer to defend, indemnify, and hold SEA-BIRD ELECTRONICS, INC. harmless from all product liability claims arising from the use or servicing of this system.

# Declaration of Conformity

Sea-Bird Electronics, Inc.  
13431 NE 20<sup>th</sup> Street, Bellevue, WA 98005 USA

## DECLARATION OF CONFORMITY

**Manufacturer's Name:** Sea-Bird Electronics  
**Manufacturer's Address:** 13431 NE 20<sup>th</sup> Street  
Bellevue, WA 98005, USA

**The Authorized Representative located within the Community is:**  
OTT MESSTECHNIK GmbH & Co.KG  
P.O.Box: 2140 / 87411 Kempten / Germany  
Ludwigstrasse 16 / 87437 Kempten  
Internet: <http://www.ott.com>  
Phone: +49 831 5617 – 100  
Fax: +49 831 5617 - 209

**Device Description:** Various Data Acquisition Devices and Sensors

**Model Numbers:**

3S	3F	3plus	4C	4M	5T	5P	5M	7
8	9plus	11plus	14	16plus V2	16plus-IM V2		17plus V2	18
19plus V2	21	25plus	26plus	27	29	32	32C	32SC
33	35	35RT	36	37-IMP	37-IM	37-SMP	37-SM	37-SIP
37-SI	38	39	39-IM	41	41CP	43	43F	44
45	49	50	52-MP	53BPR	54	55	56	63
SIM	ICC	IMM	PDIM	AFM	90488	90204	90402	90504
Glider Payload CTD		NiMH Battery Charger and Battery Pack						

**Applicable EU Directives:** Machinery Directive 98 / 37 /EC  
EMC Directive 2004 / 108 /EC  
Low Voltage Directive (73 / 23 /EEC) as amended by (93 / 68 /EEC)

**Applicable Harmonized Standards:**  
EN 61326-1:2006 Class A Electrical Equipment for Measurement, Control, and Laboratory Use, EMC Requirement – Part 1: General Requirements  
(EN 55011:2007 Group 1, Class A)  
  
EN 61010-1:2001, Safety Requirements for Electrical Equipments for Measurement, Control, and Laboratory Use – Part 1: General Requirements

Declaration based upon compliance to the Essential Requirements and Letter of Opinion from CKC Certification Services, LLC., Notified Body 0976

I, the undersigned, hereby declare that the equipment specified above conforms to the above European Union Directives and Standards.

Authorized Signature:   
Name: Nordeen Larson  
Title of Signatory: President  
Date: 27 June 2012  
Place: Bellevue, WA

# Table of Contents

<b>Limited Liability Statement</b> .....	<b>2</b>
<b>Declaration of Conformity</b> .....	<b>3</b>
<b>Table of Contents</b> .....	<b>4</b>
<b>Section 1: Introduction</b> .....	<b>6</b>
About this Manual .....	6
Unpacking ECO .....	6
<b>Section 2: Description of ECO</b> .....	<b>7</b>
System Description .....	7
System Configurations.....	9
Autonomous Data Acquisition and Control (no conducting wire required) with Auto-Fire Feature .....	9
Real-Time Data Acquisition and Control Using SBE 33 Carousel Deck Unit .....	10
Specifications.....	11
Battery Endurance.....	12
Dimensions and Connectors .....	12
Cables and Wiring .....	14
<b>Section 3: Mechanically Preparing ECO for Deployment</b> .....	<b>16</b>
Mounting Bottles .....	16
Mounting Electronics Control Module and Instruments.....	17
Rigging and Cocking Lanyards.....	18
<b>Section 4: Deploying and Operating ECO – General Information</b> 21	
Optimizing Data Quality.....	21
Taking Water Samples on Upcast.....	21
Holding Water Sampler Stationary before Taking Samples .....	21
Taking Samples in Well-Mixed Water to Check for Drift.....	22
Using Real-Time Control for Highest Quality Water Samples.....	22
Software Installation.....	22
Communications and Commands .....	23
<b>Section 5: Setting Up, Deploying, and Operating ECO for Autonomous Operation</b> .....	<b>24</b>
Testing and Setting Up System.....	24
Using SeatermAF.....	25
Testing and Setting Up ECO and CTD.....	28
Bottle Closure Setup Parameters.....	34
Close on Upcast .....	35
Close on Downcast .....	37
Close when Stationary .....	39
Close on Elapsed Time - Record or Do Not Record CTD Data .....	41
Command Descriptions.....	43
Commands Not Typically Sent by User .....	47
Wiring System .....	49
Deploying System.....	49
Recovery .....	51
Physical Handling.....	51
Uploading Data.....	52
ECO Data Formats.....	60
CTD Data Formats.....	61



<b>Section 6: Setting Up, Deploying, and Operating ECO for Real-Time Operation .....</b>	<b>62</b>
Wiring System .....	62
Setup and Deploying System .....	63
Recovery .....	65
Bottle Log (.bl) Data Output Formats .....	66
CTD Data Formats .....	66
<b>Section 7: Data Processing .....</b>	<b>67</b>
Data Conversion .....	68
Bottle Summary .....	71
Other Processing Modules .....	71
<b>Section 8: Routine Maintenance .....</b>	<b>72</b>
Corrosion Precautions / Cleaning .....	72
Connector Mating and Maintenance .....	73
Bottle Maintenance .....	73
Storage .....	73
Replacing / Recharging Batteries.....	74
Replacing Alkaline Batteries .....	74
Recharging Optional Nickel Metal Hydride Batteries .....	75
Recharging Optional Nickel-Cadmium Batteries .....	77
Removing / Replacing Latches .....	78
<b>Glossary .....</b>	<b>79</b>
Safety and Electrical Symbols .....	80
<b>Appendix I: Making and Rigging Lanyards.....</b>	<b>81</b>
Lower Lanyard.....	82
Upper Lanyard .....	83
Middle Lanyard.....	84
<b>Appendix II: Electronics Control Module Disassembly/Reassembly .....</b>	<b>86</b>
<b>Appendix III: Replacement Parts.....</b>	<b>87</b>
<b>Appendix IV: Manual Revision History .....</b>	<b>90</b>
<b>Index.....</b>	<b>92</b>

# Section 1: Introduction

This section includes a description of the scope of this manual, and a list of what is included with a typical ECO shipment.

---

## About this Manual

This manual is to be used with the SBE 55 ECO Water Sampler. It is organized to guide the user in preparing the ECO for operation. We've included system operation, detailed specifications, installation instructions, maintenance information, command descriptions, and helpful notes throughout the manual.

The ECO can be operated and controlled:

- Autonomously via its built-in auto fire feature – see *Section 5: Setting Up, Deploying, and Operating ECO for Autonomous Operation* for details.
- In real-time, via the SBE 33 Carousel Deck Unit – see *Section 6: Setting Up, Deploying, and Operating ECO for Real-Time Operation* for an overview; see the SBE 33 manual for details.

Sea-Bird welcomes suggestions for new features and enhancements of our products and/or documentation. Please contact us with any comments or suggestions ([seabird@seabird.com](mailto:seabird@seabird.com) or 425-643-9866). Our business hours are Monday through Friday, 0800 to 1700 Pacific Standard Time (1600 to 0100 Universal Time) in winter and 0800 to 1700 Pacific Daylight Time (1500 to 0000 Universal Time) the rest of the year.

---

## Unpacking ECO

A typical ECO shipment includes:

- Fully assembled ECO, with Electronics Control Module (ECM), 1 or 2 lanyard release assemblies, 3 or 6 bottles, and frame.
- Cables - number and type is dependent on which CTD is to be used with the ECO and whether the ECO will be operated autonomously or in real-time. Cables always include:
  - ECM to computer data I/O cable extender (6-pin to 4-pin)
  - ECM to computer data I/O cable (4-pin to 9-pin DB-9S)
  - ECM to lanyard release assembly cable (1 or 2 for 3- or 6-bottle system respectively) (4-pin to 4-pin)
- Software, and electronic copies of this user manual and software manuals on CD-ROM
- Spare battery end cap hardware kit
- Spare jackscrew kit

# Section 2: Description of ECO

This section describes the functions and features of the SBE 55 ECO Water Sampler, specifications, dimensions, bulkhead connectors, and system configuration.

## System Description

### Notes:

- The SBE 49 can be used with the ECO only for real-time data acquisition and water sampling with an SBE 33 Carousel Deck Unit.
- The SBE 19, 19*plus*, 19*plus* V2, 25, and 25*plus* simultaneously record data in memory while transmitting data in real-time to the ECO (for autonomous sampling) or to the Deck Unit. The SBE 49 does not have internal memory.

The SBE 55 ECO Water Sampler is the ideal small-boat, continuously operating water sampler for coastal, estuarine, and large lake ecological monitoring, to depths of 600 meters. Available in 3-bottle or 6-bottle configurations, the ECO Sampler is light and economical and can be integrated with an SBE 19, 19*plus*, 19*plus* V2, 25, 25*plus*, or 49 CTD. The SBE 55 is primarily intended for self-contained autonomous operation, and can be programmed to close bottles at selected depths, allowing deployment with ordinary wire rope. The SBE 55 also can be used for real-time CTD data and water sampling operation with an SBE 33 Carousel Deck Unit (requires electro-mechanical cable and slip-ring equipped winch).

ECO Sampler features include:

- Small, robust, lightweight package
- Reliable, efficient, user-friendly design
- Open structure improves flushing and minimizes drag
- Fire bottles in any order

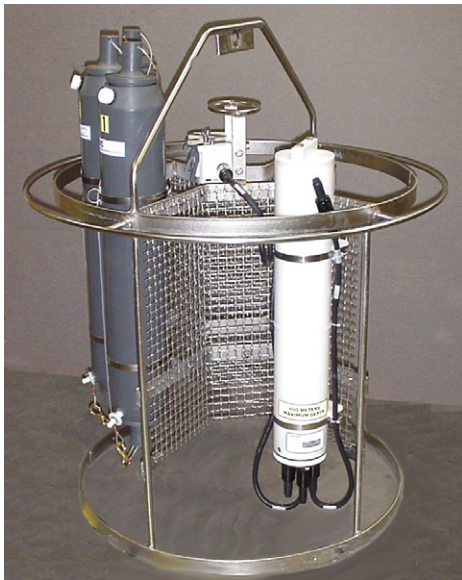

*With one 3-position lanyard release assembly and 3 bottles*

The heart of every ECO Sampler is a magnetically actuated lanyard release. A pressure-proof electromagnet at each bottle position is energized on command to release a latch holding the bottle lanyard. Only the magnetic pulse – not a moving part – trips each lanyard release mechanism. Bottles may be fired sequentially or any order. The ECO's unique design allows the lanyard release mechanism to be *cocked* with a touch of a finger before the lanyards are secured, permitting fast, convenient, safe, and reliable setup. The ECO is available with one or two 3-position release assemblies, each connecting to a separate connector on the Electronics Control Module (ECM), allowing easy do-it-yourself expansion from a three-bottle to a six-bottle system.

The lanyard release is the same one used in the SBE 32 Carousel Water Sampler, extensively deployed throughout the world's oceans, where it has built a reputation for reliability and ease-of-use. The release assembly's modular construction makes servicing easy. Titanium, acetal plastic, and other corrosion-resistant materials are used in the latch and magnet assembly.

The energy used to trip the magnetic trigger that controls each release latch is stored in an internal capacitor. When a fire command is received, the ECO switches the capacitor to the selected magnetic trigger for 20 milliseconds. A fire-confirm circuit detects current flowing through the circuit. Receipt of a fire-confirm message from the ECO verifies the bottle position selected and that energy was delivered to the magnetic trigger. The capacitor is charged to 70 volts with a current-limited DC/DC converter; time to recharge the capacitor is approximately 4 seconds.

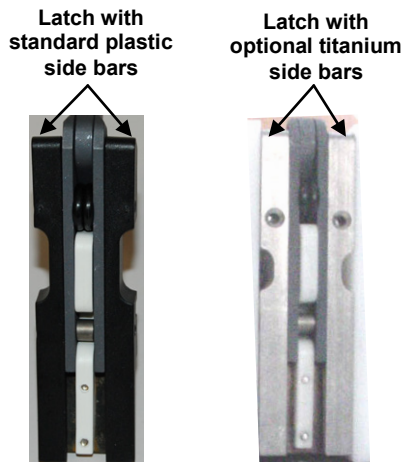

The ECO Sampler includes the Electronics Control Module (ECM) with aluminum end cap and alkaline batteries, one 3-position lanyard release assembly, latches with standard plastic side bars, stainless steel guard frame, lifting bail, and sturdy mesh panels for mounting the ECM, CTD, and other sensors that may be integrated with the CTD (e.g., dissolved oxygen sensor, fluorometer, turbidity sensor, etc.). Band clamps are used to mount the bottles.

Options include:

- Additional 3-position lanyard release assembly (allows for system use with 6 bottles)
- Titanium end cap in place of standard aluminum end cap
- Wet-pluggable MCBH connectors in place of standard glass-reinforced epoxy connectors
- Latches with titanium side bars, for more demanding applications
- Nickel Metal Hydride (NiMH) rechargeable batteries in a removable battery pack, and battery charger and associated cables

Future upgrades and enhancements to the Electronics Control Module firmware can be easily installed in the field through a computer serial port and the *Computer* bulkhead connector on the ECM, without the need to return the equipment to Sea-Bird.

#### Notes:

- Help files provide detailed information on the software.
- Separate software manuals on CD-ROM contain detailed information on Seasave and SBE Data Processing.
- Sea-Bird supplies the current version of our software when you purchase an instrument. As software revisions occur, we post the revised software on our FTP site. See our website ([www.seabird.com](http://www.seabird.com)) for the latest software version number, a description of the software changes, and instructions for downloading the software from the FTP site.

Sea-Bird equipment is supplied with a powerful Windows software package, Seasoft V2, which includes:

- **Seaterm** and **SeatermV2** – terminal programs for easy communication and data retrieval. SeatermV2 is for use with the SBE 19*plus* V2 and 25*plus*.
- **SeatermAF V2** – terminal program for easy communication and data retrieval for setting up auto-fire (autonomous) operation. Referred to as SeatermAF for brevity.
- **Seasave V7** – program for acquiring, converting, and displaying real-time or archived raw data.
- **SBE Data Processing** - program for calculation and plotting of conductivity, temperature, pressure, auxiliary sensor data, and derived variables such as salinity and sound velocity.

## System Configurations

### Autonomous Data Acquisition and Control (no conducting wire required) with Auto-Fire Feature

The ECO can operate autonomously on non-conducting cables, with or without a CTD. Power is supplied to the ECO by its internal batteries.

- Used with an **SBE 19 / 19plus / 19plus V2, 25 / 25plus CTD**, the ECO monitors the pressure data transmitted by the instrument in real-time, and fires bottles at predefined pressures (depths) on upcast or downcast, or whenever the system is stationary for a specified period of time. Bottle number, firing confirmation, and five scans of CTD data are recorded in ECO memory for each bottle fired. At the end of a cast, the bottle data (.afm) file is uploaded from the ECO, and the CTD data is uploaded from the CTD (through the AFM).
- Used **without a CTD**, the ECO is programmed to fire bottles at predefined intervals of elapsed time. The point at which samples are taken is determined (approximately) by monitoring cable payout and elapsed time. The ECO records bottle sequence and number, date and time, and firing confirmation for each bottle fired. At the end of a cast, the bottle data (.afm) file is uploaded from the ECO.

**Note:**

The SBE 19, 19plus, 19plus V2, 25, and 25plus simultaneously record data (including pressure) in memory while transmitting pressure data in real-time to the ECO.

### SBE 55 Autonomous Operation

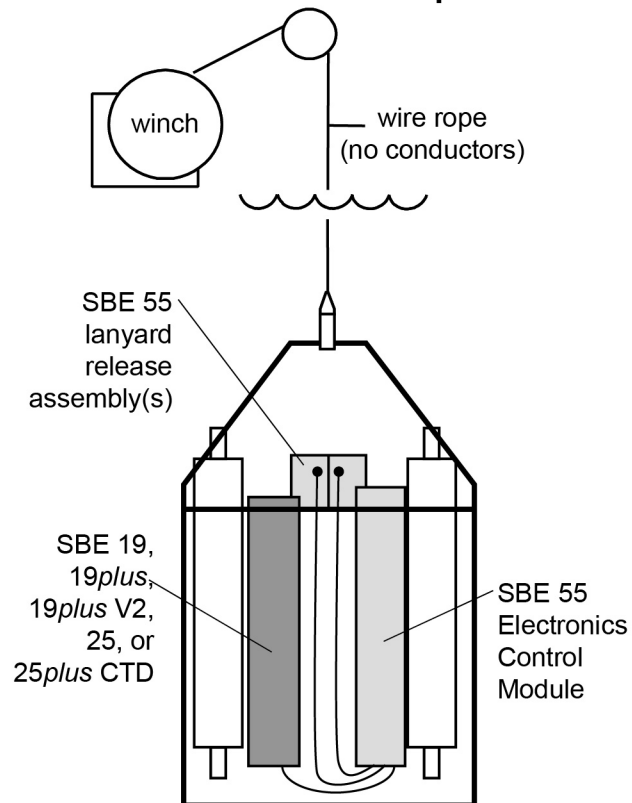

## Real-Time Data Acquisition and Control Using SBE 33 Carousel Deck Unit

The ECO's Electronics Control Module includes a winch cable connector for real-time use. Users can switch from autonomous to real-time operation at any time by connecting the winch cable to the ECM, and connecting the SBE 33 Carousel Deck Unit to AC power and the winch slip rings. The ECO is then powered and controlled using the SBE 33 Carousel Deck Unit, and can be used with or without a CTD (**SBE 19 / 19plus / 19plus V2, 25 / 25plus, or 49 CTD**). The interface provides real-time data telemetry capability and surface power for these CTDs and their auxiliary sensors, and permits control of the ECO through the SBE 33 or via Seasave. When used without a CTD, bottles are closed with the SBE 33 front panel controls; depth determination must be approximated by monitoring the cable payout.

The SBE 33 has a NMEA Interface to support NMEA 0183 protocol, and an interface for a Surface PAR sensor.

### Notes:

- For real-time operation, connection to two serial ports on the computer is required. COM1 (CTD data channel) and COM2 (Water Sampler command channel) are the defaults, and are shown in the diagrams for illustration only. You can use any two ports, in any order; set up the serial port configuration in Seasave to correspond.
- SBE 33's NMEA interface was optional prior to 2010.
- SBE 33's Surface PAR interface was optional prior to 2012.
- When using the SBE 49 FastCAT with the SBE 33, Seasave (real-time data acquisition software) does not support acquisition of Surface PAR data.
- Seasave 7.19 or later also supports acquisition of data from a NMEA device connected directly to the computer (instead of the deck unit).

### SBE 55 Real-Time Operation

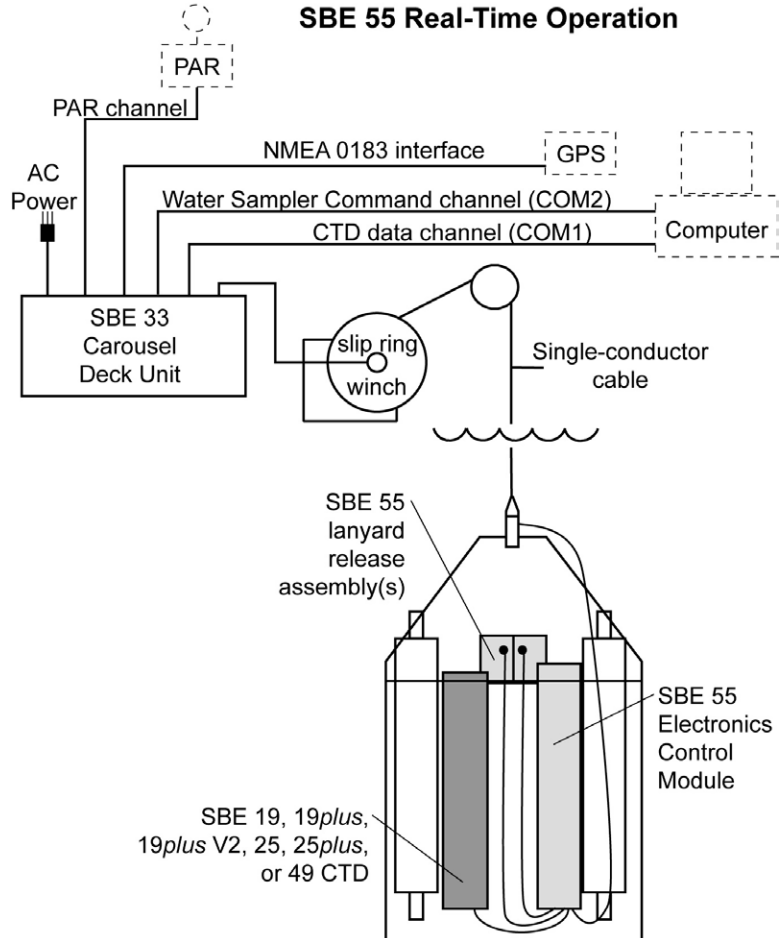



## Specifications

<b>Power</b>	<p><i>External power requirement (maximum):</i> 12 - 15VDC, 0.25A</p> <p><i>Sea cable power requirement (maximum):</i> 100VDC – 375VDC, 50W</p> <p><i>Quiescent (sleep) Current:</i> 15 microamps</p> <p><i>Operating Current:</i></p> <ul style="list-style-type: none"> <li>• Not armed, connected to computer - 2.5 milliAmps</li> <li>• Not armed, disconnected from computer, but not in quiescent state yet - 1 milliAmp</li> <li>• Armed, capacitor charging (for 90 sec after <b>Arm</b> command is sent) - 150 milliAmps</li> <li>• Armed, capacitor charged (current draw until last bottle is fired) - 10 milliAmps</li> </ul>
<b>Internal Batteries (for autonomous operation)</b>	<p><i>Standard:</i> Nine alkaline D-cells (Duracell MN 1300, LR-20, nominal capacity 14 Amp-hours; use 10.5 Amp-hours for planning purposes).</p> <p><i>Optional:</i> Rechargeable Nickel-Metal Hydride battery pack (nominal capacity 8 Amp-hours) or Nickel-Cadmium battery pack (nominal capacity 4.4 Amp-hours).</p> <p>See <i>Battery Endurance</i> for example capacity calculation.</p>
<b>Memory and Data Storage (for autonomous operation)</b>	<p>EEPROM memory provides memory space for 1 cast. Records for each bottle fired:</p> <ul style="list-style-type: none"> <li>• Bottle sequence and number, date and time, firing confirmation, battery voltage, scan number of first of 5 CTD scans, and 5 scans of CTD data, or</li> <li>• (if used without a CTD) Bottle sequence and number, date and time, firing confirmation, and battery voltage</li> </ul>
<b>Depth Rating</b>	600 meters
<b>Materials</b>	<p><i>Frame:</i> 316 stainless steel</p> <p><i>Latch/magnet assembly:</i> titanium, acetal plastic, and other corrosion-resistant materials</p> <p><i>Electronics Control Module housing:</i> plastic</p>
<b>Dimensions</b>	673 mm (26. 5 in.) diameter, 942 mm height (37.1 in.)
<b>Number of Bottles</b>	3 or 6 bottles
<b>Weight in air</b>	<p><i>Without CTD or Bottles:</i> 30 kg (66 lbs)</p> <p><i>With SBE 19plus* &amp; three <b>empty</b> 4-liter bottles –</i> 51 kg (113 lbs)</p> <p><i>With SBE 19plus* &amp; six <b>empty</b> 4-liter bottles –</i> 60 kg (133 lbs)</p> <p><i>With SBE 19plus* &amp; six <b>full</b> 4-liter bottles –</i> 84 kg (185 lbs)</p> <p>*Note: 19plus and 19plus V2 weights identical.</p>
<b>Winch Cable Compatibility</b>	Single or multi-core armored cable up to 10,000 meters long with inner core resistance of 0 - 350 ohms

## Battery Endurance

An example is shown below for one sampling scheme.

*Example:* ECO equipped with alkaline batteries is used to take 6 profiles/day. Each profile is complete 1 hour after ECO is armed (assume last bottle fired on upcast near surface after 1 hour), and then ½ hour is spent with ECO connected to computer, downloading data and re-arming.

Capacitor charging:  $6 \text{ profiles} * 0.150 \text{ Amps} * 90 \text{ sec charging} * 1 \text{ hour} / 3600 \text{ sec} = 0.00225 \text{ Amp-hours}$

Capacitor charged:  $6 \text{ profiles} * 0.010 \text{ Amps} * 1 \text{ hour charged} = 0.06 \text{ Amp-hours}$

Downloading data and re-arming:  $6 \text{ profiles} * 0.0025 \text{ Amps} * 0.5 \text{ hours} = 0.0075 \text{ Amp-hours}$

Quiescent:  $0.000015 \text{ Amps} * (24 \text{ hours} - 6 * 1.5 \text{ hours}) = 0.000225 \text{ Amp-Hours}$

Total =  $0.00225 + 0.06 + 0.0075 + 0.000225 = 0.07 \text{ Amp-hours/day}$

Number of days of use =  $10.5 \text{ Amp-hour capacity} / 0.07 \text{ Amp-hours/day} = 150 \text{ days}$

## Dimensions and Connectors

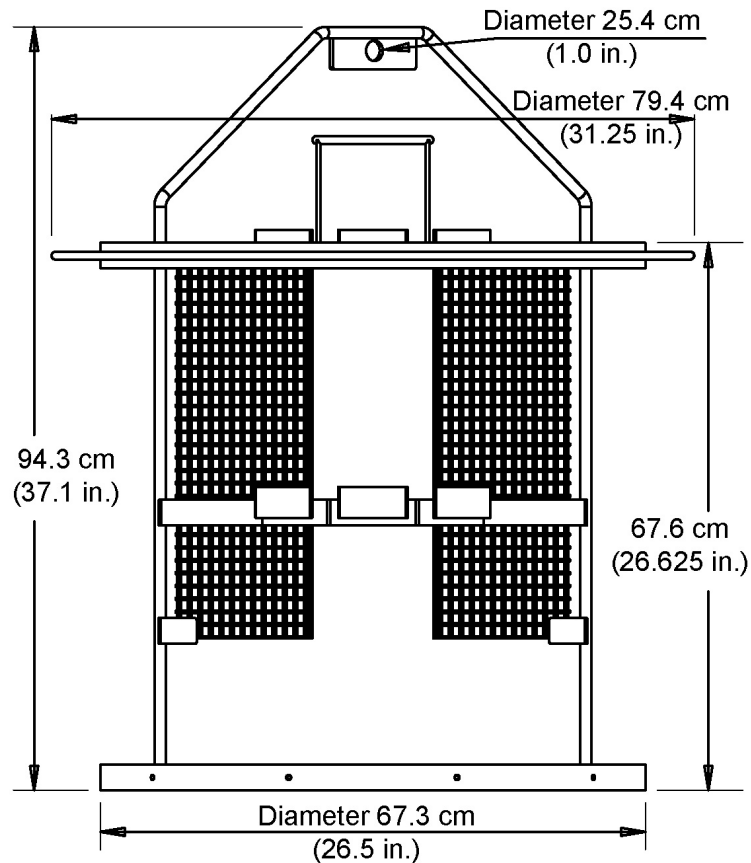

### Electronics Control Module (ECM) Connector End Cap

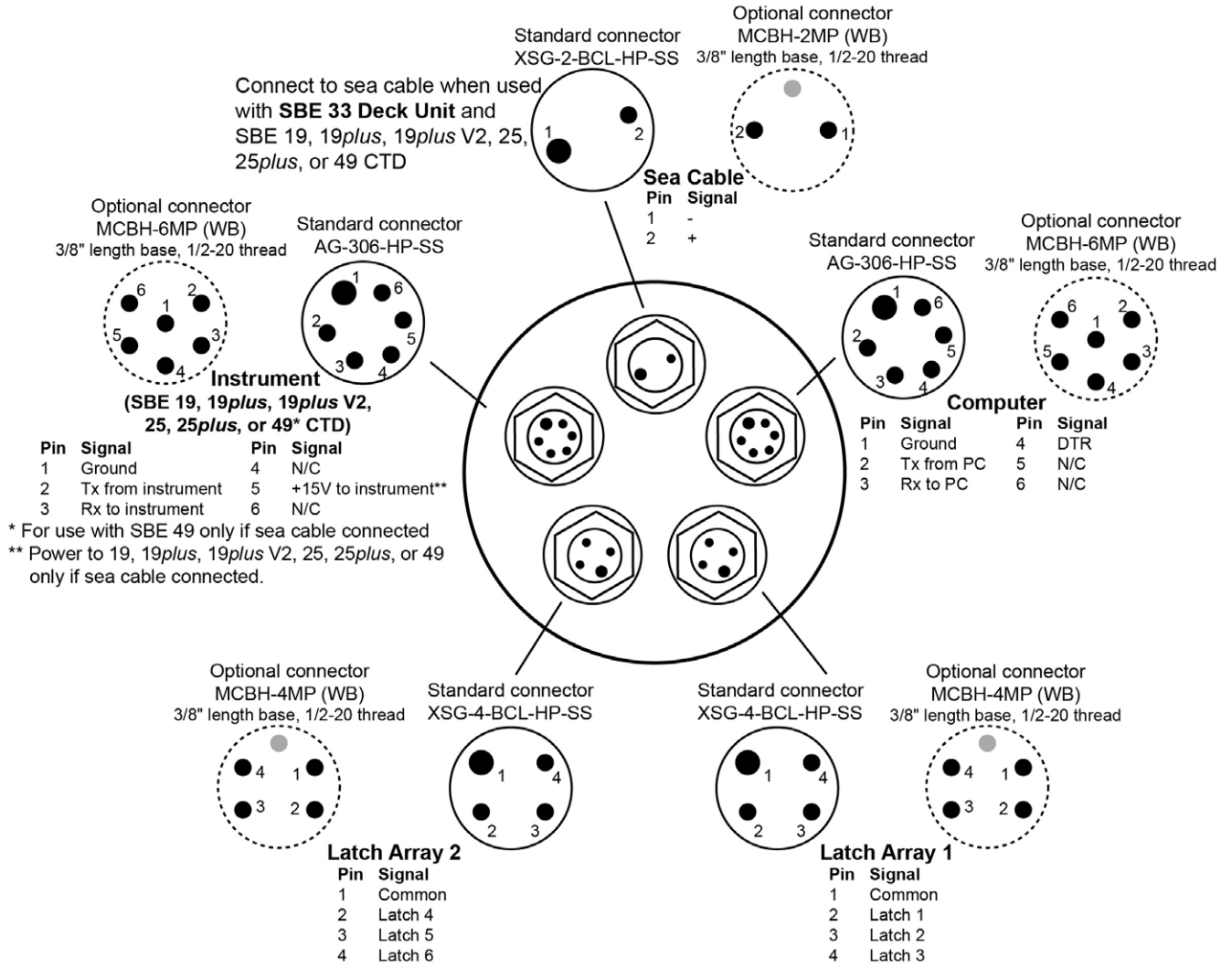

### Latch Assembly Connector (One per 3-Bottle Latch Assembly)

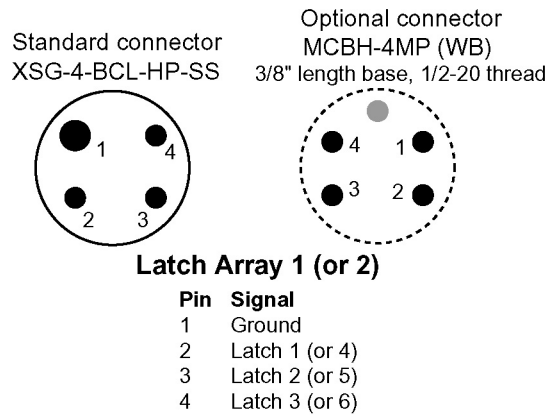

### Cables and Wiring

**6-pin to 4-pin Cable** –extension cable from SBE 55 Computer connector

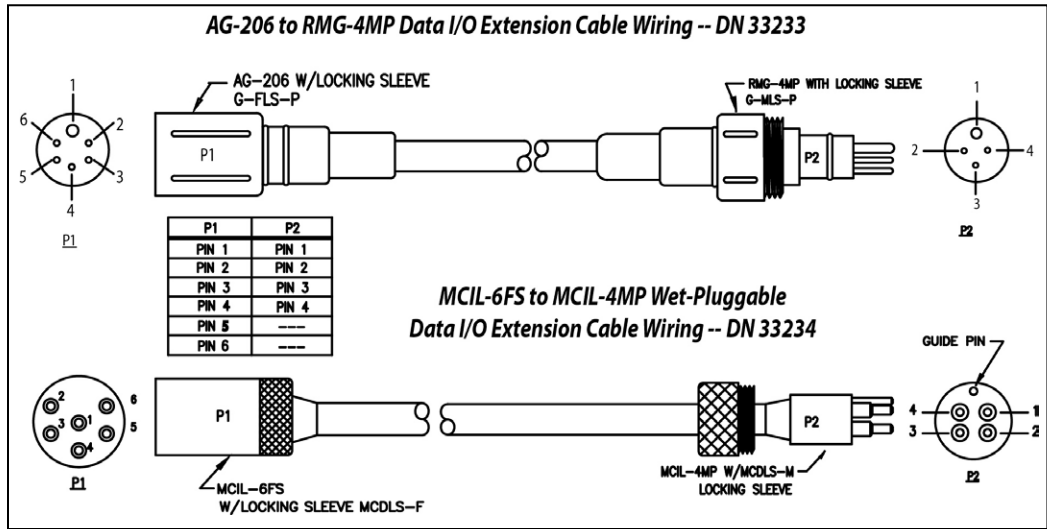

**4-pin Data I/O Cable** – from extension cable (from SBE 55 Computer connector) to computer

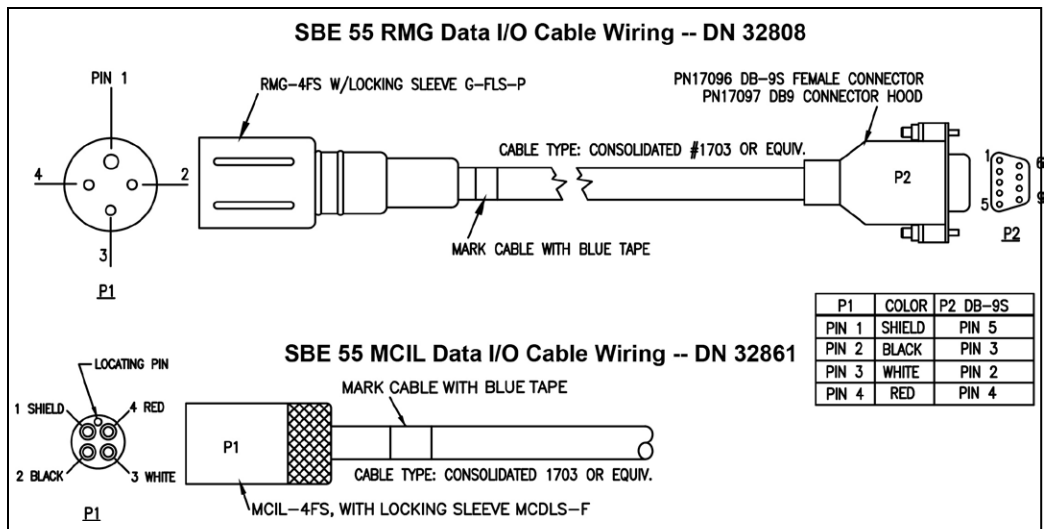

**Test Cable** – from SBE 55 Sea Cable connector to SBE 33

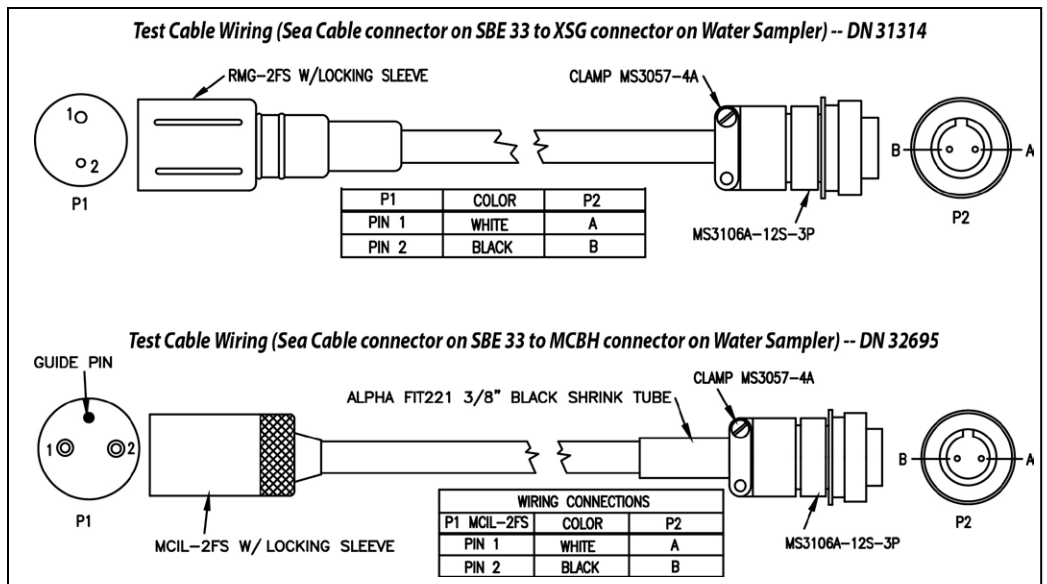

**2-pin to 2-pin Extension Cable**  
 – from SBE 55 Sea Cable connector to sea cable

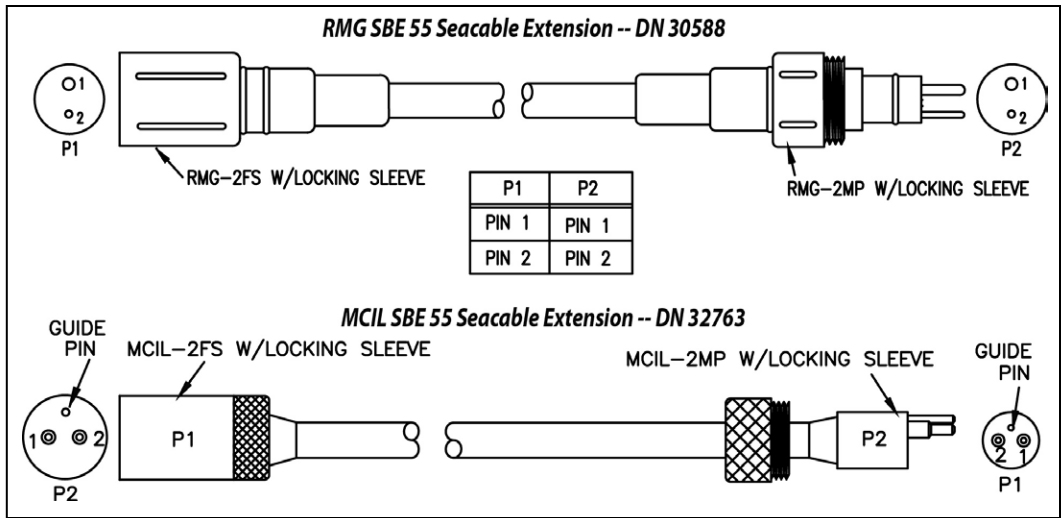

**4pin to 4-pin Latch Assembly Cable (up to 2)**  
 – from SBE 55 Latch Array connector to Latch Assembly

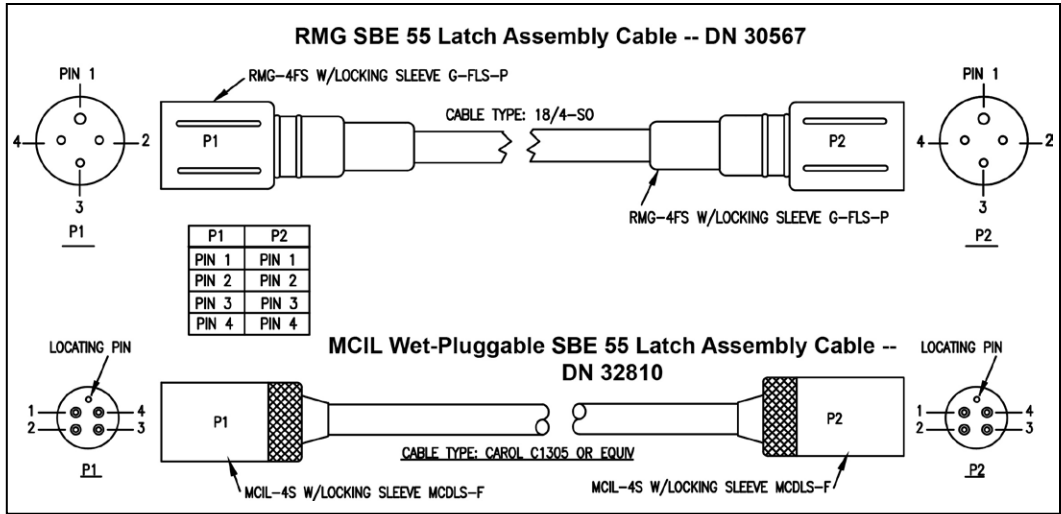

**6-pin to 4-pin CTD Cable**  
 – from SBE 55 Instrument connector to CTD (SBE 19, 19plus, 19plus V2, 25, 25plus, or 49)

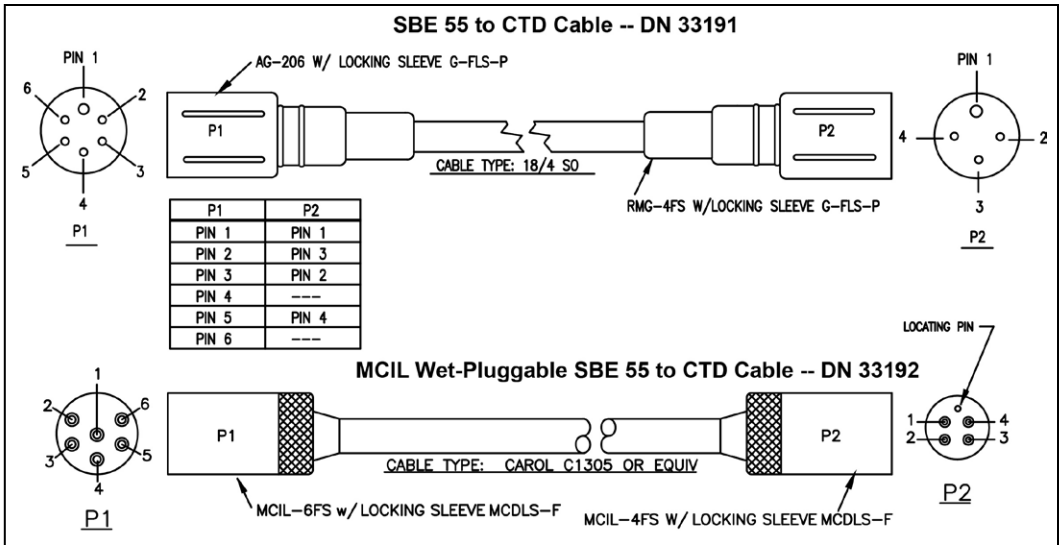

# Section 3: Mechanically Preparing ECO for Deployment

This section covers:

- Mounting bottles to ECO
- Mounting Electronics Control Module (ECM) and instruments to the ECO
- Rigging and cocking lanyards

Sea-Bird installs the ECM and bottles, and rigs lanyards on the ECO at the factory. If you purchase a CTD and auxiliary sensors at the same time as the ECO, Sea-Bird also mounts the instruments, and ships the system assembled.

## Mounting Bottles

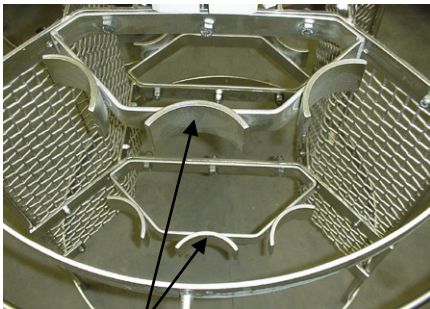

Saddle for bottle mount (top and bottom)

Bottles mount on the ECO frame's saddles with band clamps (two per bottle). The upper band clamp has a D-ring installed on it, for threading the middle lanyard through.



For *middle* bottle in group of 3 bottles, place bottle so that drain fitting is parallel to drain fitting on one of end bottles.

Place *end* bottles so that drain fitting is approximately parallel to adjacent frame, to avoid interference with lower end cap when cocked.

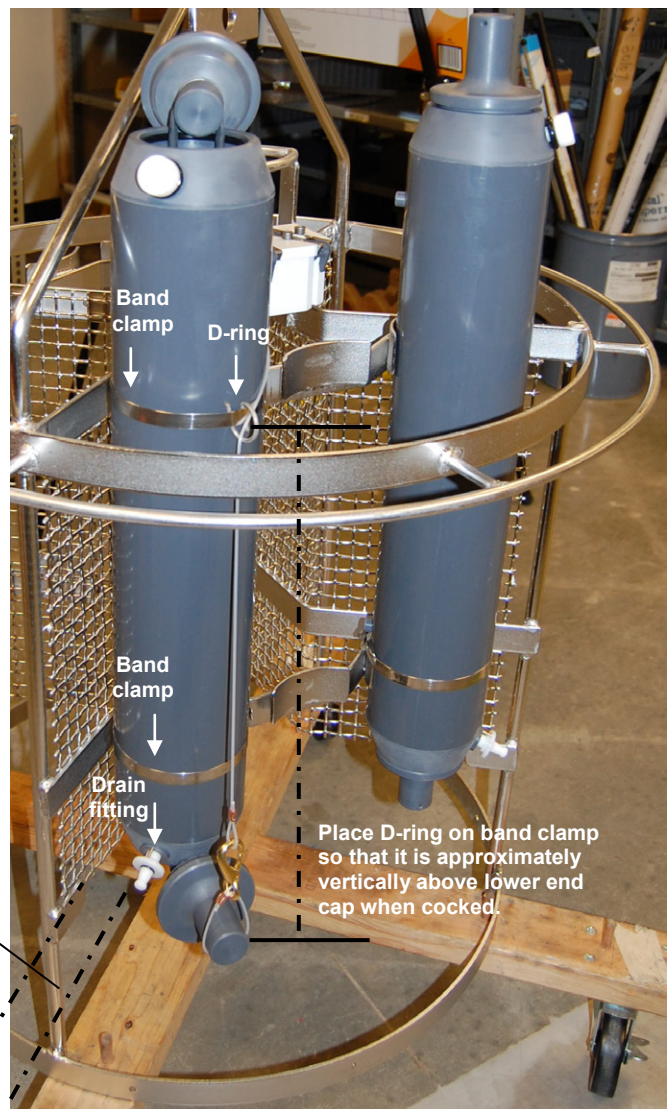



### Mounting Electronics Control Module and Instruments

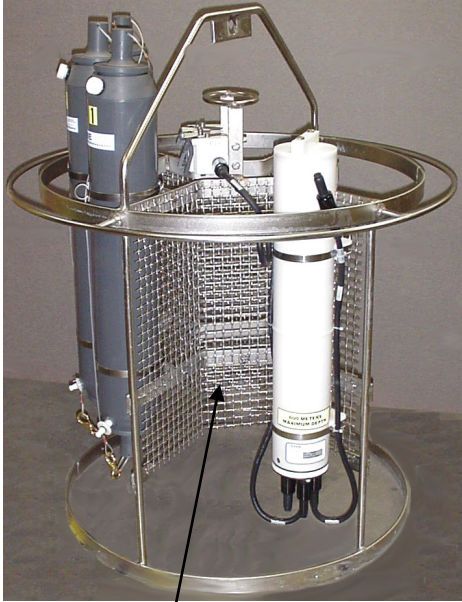

Mesh panels (2) for mounting Electronics Control Module (shown), CTD, and auxiliary sensors

To provide room for mounting a CTD and accessories, the bottle positions on the ECO are closely spaced into two arcs, centered 180 degrees apart. This leaves space between the arc ends for mounting the Electronics Control Module, a CTD, and auxiliary sensors on the ECO's mesh panels. Mounting is accomplished with two mount blocks and two band clamps for each housing. For a 3-bottle system, as shown at left, the ECM and CTD are often mounted off-center, to equilibrate the weight.

Place a layer of Teflon tape on the inside of the band clamps to provide electrical insulation between the clamps and the instrument housings.

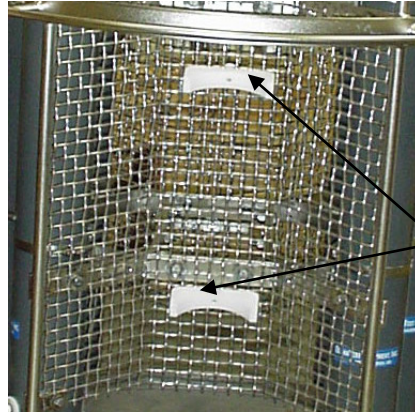

Mount blocks bolted to mesh panel

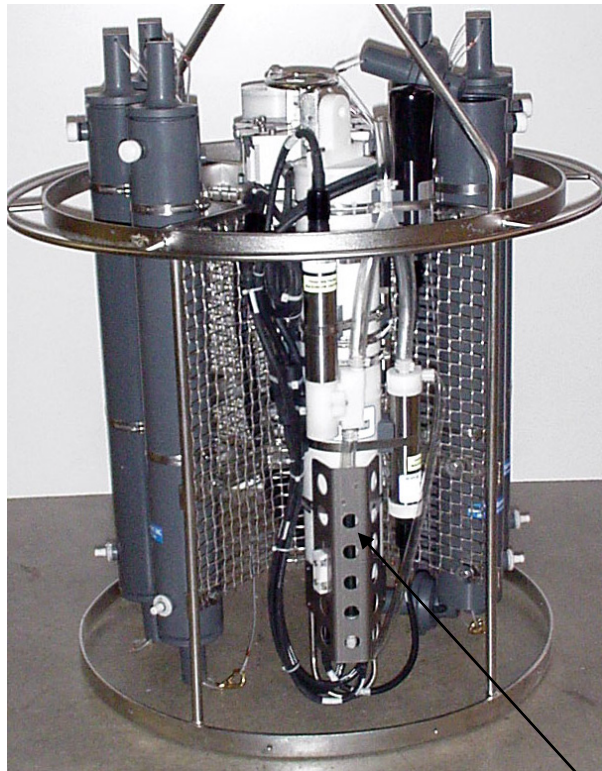

SBE 19plus with SBE 5T pump, SBE 43 DO Sensor, and Turner Cyclops-7 Fluorometer mounted on ECO's mesh panel (ECM on opposite side)

Note: Bottles in photo are custom bottles instead of standard 4-liter ECO bottles.

## Rigging and Cocking Lanyards

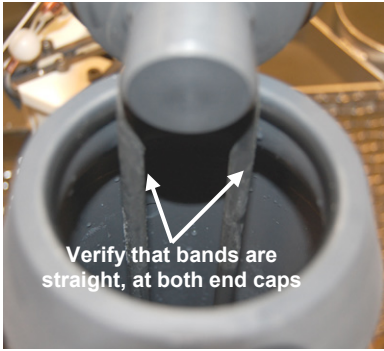

Before you start, verify that the bottle orientation on the frame is correct (see *Mounting Bottles* above) and that the internal bands in the bottle are straight.

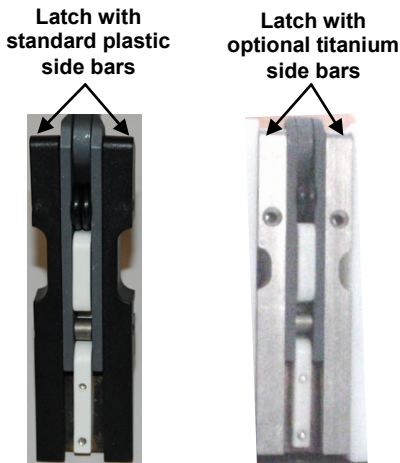

**CAUTION:** Some customers use aircraft wire in place of the recommended nylon monofilament lanyards. **Do not use aircraft wire on an ECO with latches with standard plastic side bars;** aircraft wire will damage the plastic side bars.

1. Unclip the lower lanyard from the middle lanyard.
2. Release (*uncock*) the mechanism by pushing on the white plastic trigger release.

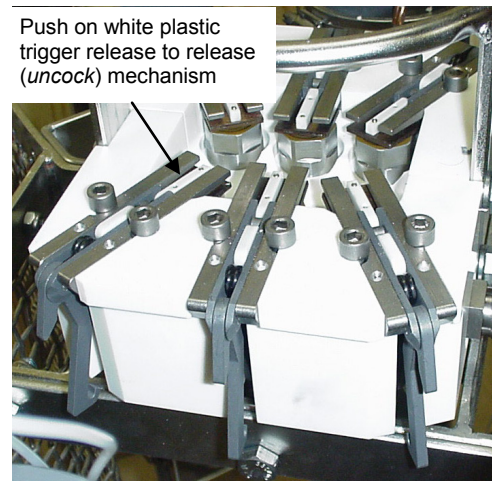
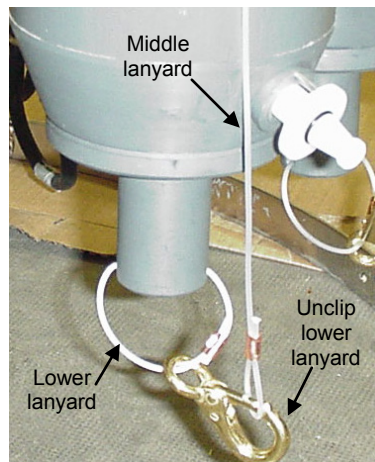



3. Pulling the bottle top cap toward the latch, thread the upper lanyard over the *football*-shaped framework, and attach the upper lanyard to the trigger.
4. Cock the release mechanism by pushing against the trigger until it clicks and locks in place.

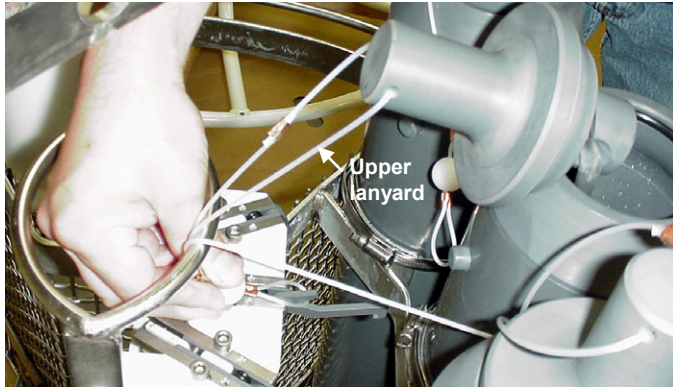

Pull bottle top cap toward latch. Thread end of upper lanyard through *football*-shaped frame. Attach upper lanyard to latch.

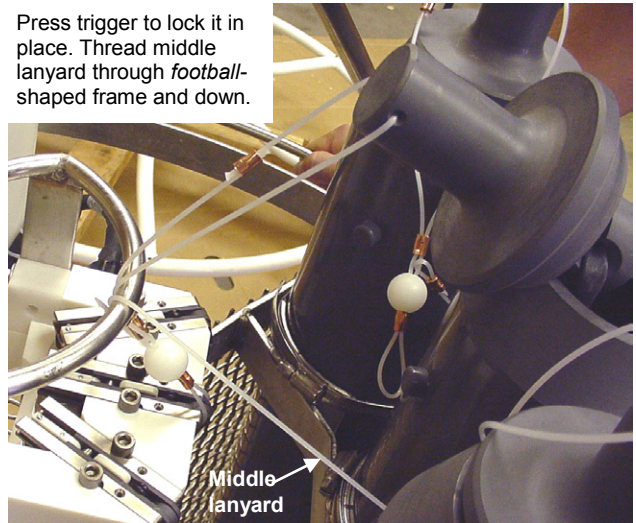

**Note:** In some cases, the trigger may not click in place due to residual magnetic force in the trigger release mechanism. If this happens: Push on the outer portion of the white plastic trigger release. Then, push the trigger until it clicks in place.

If trigger will not lock in place due to residual magnetic force, push on this part of the trigger release mechanism. Then, push trigger until it clicks in place.

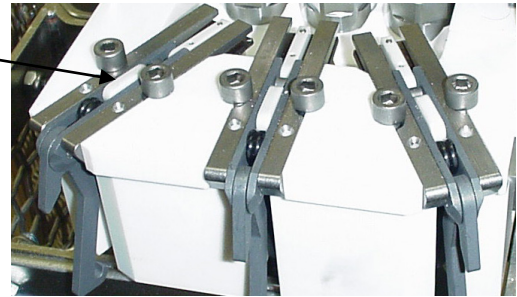

5. Thread the middle lanyard up and over the top of the *football-shaped* framework, and through the D-ring on the outside of the top band clamp on the bottle.
6. Pull the bottom end cap out (away from) the center of the ECO. Clip the lower lanyard to the middle lanyard.

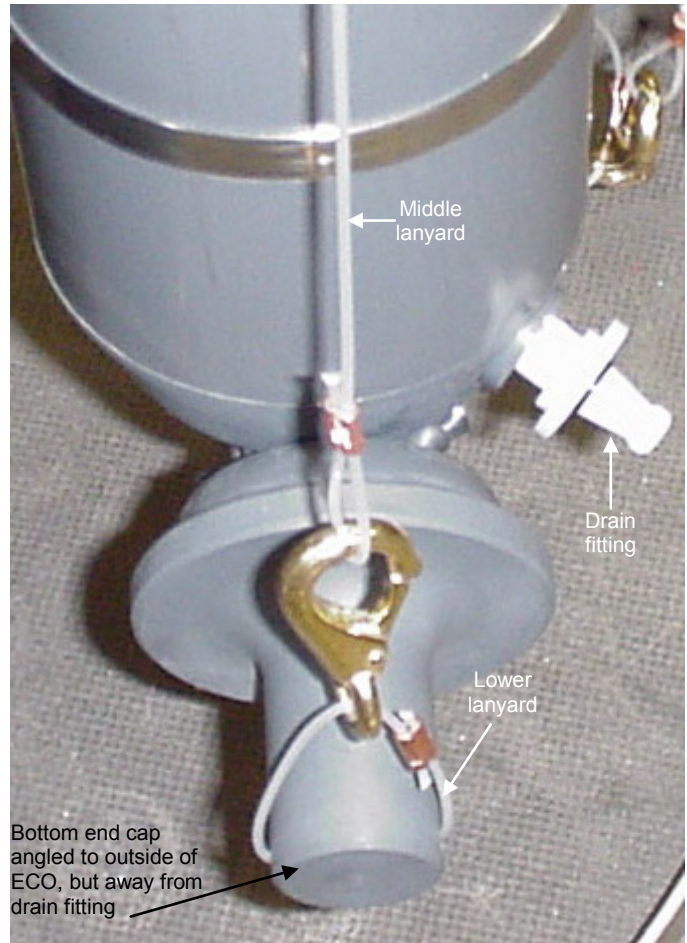
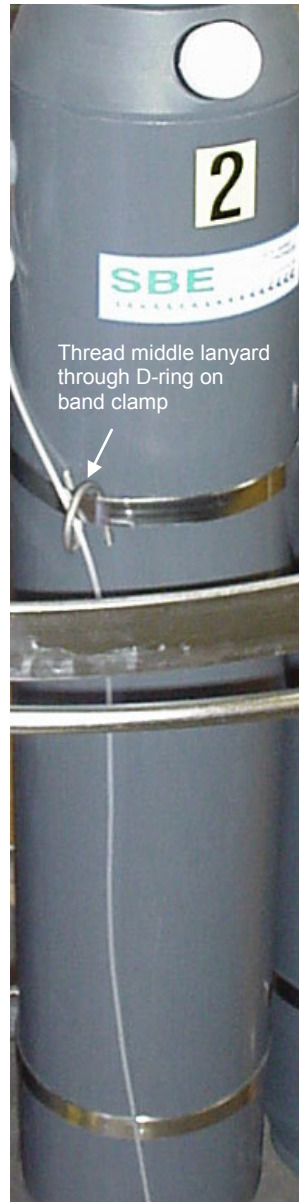

# Section 4: Deploying and Operating ECO – General Information

**Note:**

Separate software manuals (on CD-ROM) and Help files contain detailed information on installation, setup, and use of Sea-Bird's terminal programs, real-time data acquisition software, and data processing software.

This section includes discussions of:

- Optimizing data quality
- Software installation
- Commands to the ECO

System wiring, setup, operation, recovery, and data processing are covered in *Section 5: Setting Up, Deploying, and Operating ECO for Autonomous Operation* and *Section 6: Setting Up, Deploying, and Operating ECO for Real-Time Operation*.

---

## Optimizing Data Quality

### Taking Water Samples on Upcast

Most of our CTD manuals refer to **using downcast CTD data to characterize the profile**. For typical configurations, downcast CTD data is preferable, because the CTD is oriented so that the intake is *seeing* new water before the rest of the package causes any mixing or has an effect on water temperature.

If you take water samples on downcast, the pressure on an already closed bottle increases as you continue through the downcast; if there is a small leak, outside water is forced into the bottle, contaminating the sample with deeper water. Conversely, if you take water samples on upcast, the pressure decreases on an already closed bottle as you bring the package up; any leaking results in water exiting the bottle, leaving the integrity of the sample intact. Therefore, standard practice is to monitor real-time downcast data to determine where to take water samples (locations with well-mixed water and/or with peaks in the parameters of interest), and then **take water samples on upcast**.

### Holding Water Sampler Stationary before Taking Samples

If the CTD/water sampler package does not stop before you fire a bottle, the water in the bottle is a mixture of water from many meters below the firing point (assuming you are taking water samples on upcast). If moving at 1 m/sec, a bottle's *flushing constant* is typically five to eight volumes, with water flushing slowly at the bottle inside wall and faster toward the bottle center. For a 4-liter bottle, the trapped sample contains a mixture of water from a cylinder in the water column with diameter equal to the bottle inner diameter and a volume of 20 - 32 liters (i.e., height of the cylinder is five to eight times the bottle height).

Therefore, standard practice is to **stop the package to allow the bottle to flush freely for several minutes before each bottle closing**.

## Taking Samples in Well-Mixed Water to Check for Drift

Oceanographic conditions (for example, internal waves and currents) result in density surfaces moving continuously, causing water of a given salinity to move up and down. Therefore, standard practice is to monitor the real-time temperature / salinity / density structure during the downcast, **stopping the water sampler on upcast at depths where gradients are small before closing bottles that will be used to check for calibration drift.**

You can use the data associated with each bottle firing to check for calibration drift, by comparing data from the CTD / auxiliary sensors to lab measurements made on the water in the bottles.

## Using Real-Time Control for Highest Quality Water Samples

If using an autonomous sampling system, the ECO can be programmed to sample when stationary, eliminating the flushing problem caused by sampling without first stopping. However, the lack of real-time data can still result in samples being taken in areas with large gradients, because the user can only estimate the depth of the gradients, **and** can only estimate the actual package depth from the cable payout.

For these reasons, water sampling with a real-time system (control via SBE 33 Deck Unit) is preferable to autonomous sampling (pre-programmed).

**Autonomous sampling does not provide water sample quality that is equal to that from real-time sampling; it is a compromise intended to serve users who do not have real-time capability on their vessel.**

---

## Software Installation

### Notes:

- Help files provide detailed information on the software.
- Separate software manuals on CD-ROM contain detailed information on Seasave and SBE Data processing.
- Sea-Bird also supplies an older version of Seasave, Seasave-Win32. However, all Seasave instructions in this manual are written for Seasave V7. See Seasave-Win32's manual and/or Help files if you prefer to use the older software; note that Seasave-Win32 is not compatible with the SBE 19*plus* V2.
- Sea-Bird supplies the current version of our software when you purchase an instrument. As software revisions occur, we post the revised software on our FTP site. See our website ([www.seabird.com](http://www.seabird.com)) for the latest software version number, a description of the software changes, and instructions for downloading the software from the FTP site.

Seasoft V2 was designed to work with a PC running Windows XP service pack 2 or later, Windows Vista, or Windows 7.

If not already installed, install Sea-Bird software programs on your computer using the supplied software CD:

1. Insert the CD in your CD drive.
2. Double click on **SeasoftV2.exe**. Follow the dialog box directions to install the software. Install all the components, or as a minimum install Seaterm (terminal program), SeatermAF V2 (terminal program for setting up auto fire parameters), SeatermV2 (terminal program for use when directly communicating with an SBE 19*plus* V2), Seasave V7 (real-time data acquisition), and SBE Data Processing (data processing).

The default location for the software is c:\Program Files\Sea-Bird. Within that folder is a sub-directory for each program (Seaterm, SeatermAF, etc.).



## Communications and Commands

During normal operation, commands are sent automatically to the ECO by the system controlling the ECO's operation. These commands are included here for reference. All command characters must be upper case (capital letters).

Command to ECO	Description																
#SR	Go to home position (position #1).																
#SF	Fire next position (sequential firing).																
#SNx	Fire position x (first position is 1), where x is in ASCII.																
	<table border="1"> <thead> <tr> <th>Position #</th> <th>Command</th> <th>Position #</th> <th>Command</th> </tr> </thead> <tbody> <tr> <td>1</td> <td>#SN1</td> <td>4</td> <td>#SN4</td> </tr> <tr> <td>2</td> <td>#SN2</td> <td>5</td> <td>#SN5</td> </tr> <tr> <td>3</td> <td>#SN3</td> <td>6</td> <td>#SN6</td> </tr> </tbody> </table>	Position #	Command	Position #	Command	1	#SN1	4	#SN4	2	#SN2	5	#SN5	3	#SN3	6	#SN6
	Position #	Command	Position #	Command													
	1	#SN1	4	#SN4													
2	#SN2	5	#SN5														
3	#SN3	6	#SN6														
#SBx	Set ECO to CTD communication baud rate x:																
	<table border="1"> <thead> <tr> <th>Baud Rate</th> <th>Command</th> </tr> </thead> <tbody> <tr> <td>600 baud</td> <td>#SB0</td> </tr> <tr> <td>1200 baud</td> <td>#SB1</td> </tr> <tr> <td>2400 baud</td> <td>#SB2</td> </tr> <tr> <td>4800 baud</td> <td>#SB3</td> </tr> </tbody> </table>	Baud Rate	Command	600 baud	#SB0	1200 baud	#SB1	2400 baud	#SB2	4800 baud	#SB3						
	Baud Rate	Command															
	600 baud	#SB0															
	1200 baud	#SB1															
2400 baud	#SB2																
4800 baud	#SB3																

The ECO sends one of these ASCII replies upon receipt of a reset (go to home position) or bottle fire command:

Reply from ECO *	Description																
□!□	At home position, next bottle to fire is #1.																
□#□	Received invalid bottle number.																
□\$□	Did not confirm bottle fire.																
□ x □	Fired bottle x (first position is 1), where x is in ASCII.																
	<table border="1"> <thead> <tr> <th>Position</th> <th>Reply</th> <th>Position</th> <th>Reply</th> </tr> </thead> <tbody> <tr> <td>1</td> <td>□ 1 □</td> <td>4</td> <td>□ 4 □</td> </tr> <tr> <td>2</td> <td>□ 2 □</td> <td>5</td> <td>□ 5 □</td> </tr> <tr> <td>3</td> <td>□ 3 □</td> <td>6</td> <td>□ 6 □</td> </tr> </tbody> </table>	Position	Reply	Position	Reply	1	□ 1 □	4	□ 4 □	2	□ 2 □	5	□ 5 □	3	□ 3 □	6	□ 6 □
	Position	Reply	Position	Reply													
	1	□ 1 □	4	□ 4 □													
2	□ 2 □	5	□ 5 □														
3	□ 3 □	6	□ 6 □														

\* Note: The □ characters (they are decimal 6, which is not a printable ASCII character) may not appear, depending on the terminal program you are using.

# Section 5: Setting Up, Deploying, and Operating ECO for Autonomous Operation

For autonomous operation with the SBE 19, *19plus*, *19plus V2*, *25*, or *25plus* CTD, or with no CTD, the ECO closes bottles on upcast, on downcast, when stationary, or on elapsed time. This section provides detailed instructions on setup, commands, operation, data upload, and data format for the ECO.

---

## Testing and Setting Up System

**Note:**

See *Dimensions and Connectors and Cables and Wiring* in *Section 2: Description of ECO* for connector pin outs and cable wiring diagrams.

1. The ECO is supplied with a 6-pin to 4-pin cable extender, for connection to the ECO's 6-pin *Computer* connector (**clockwise** from the 2-pin *Sea Cable* connector on the Electronics Control Module). Connect to the extender cable with the 4-pin to 9-pin DB-9S cable; this cable (with blue tape on both ends) uses the Data Terminal Ready (DTR) line from the computer to control internal switches in the ECO. These switches allow the terminal program (SeatermAF) to communicate with the ECO or CTD without switching cables or serial ports (SeatermAF sets the DTR line high to select the ECO and low to select the CTD). **The CTD's data I/O cable is not able to communicate with the ECO.**
  - A. If there is a dummy plug on the connector, remove as follows:
    - (1) By hand, unscrew the locking sleeve from the connector. **If you must use a wrench or pliers, be careful not to loosen the bulkhead connector instead of the locking sleeve.**
    - (2) Remove the dummy plug from the connector by pulling the plug firmly away from the connector.
  - B. **Standard Connector** - Install the 4-pin to 9-pin DB-9S cable, aligning the raised bump on the side of the connector with the large pin (pin 1 - ground) on the cable extender. **OR**  
**MCBH Connector** - Install the 4-pin to 9-pin DB-9S cable, aligning the pins.
  - C. Connect the 9-pin end to your computer's serial port.
2. Connect the ECO's *Instrument* connector (**counter-clockwise** from the 2-pin *Sea Cable* connector on the Electronics Control Module) to the CTD, using the 6-pin to 4-pin CTD cable supplied with the system. Follow the procedure in Steps 1A and 1B when installing the cable. **Note:** SBE 19 and 25 CTDs configured with a pump, and all SBE *19plus V2* and *25plus* CTDs, have a 6-pin data I/O - pump connector. These CTDs are supplied with a Y-cable (6-pin to CTD, 4-pin data I/O, 2-pin pump); connect the ECO's Instrument connector to the 4-pin data I/O connector on the Y-cable.

## Using SeatermAF

Proceed as follows:

1. Double click on SeatermAF.exe. If this is the first time the program is used, the setup dialog box appears:

**Notes:**

- SeatermAF's initialization file, SeaTermAF.ini, includes information on the last instrument used when the program was closed, and the location of that instrument's settings (.psa) file. As a default, the .ini file is saved to %USERPROFILE%\Local Settings\Apps\Sea-Bird\ (for example c:\Documents and Settings\dbresko\Local Settings\Apps\Sea-Bird\SeatermAF.ini).
- See SeatermAF's Help files.

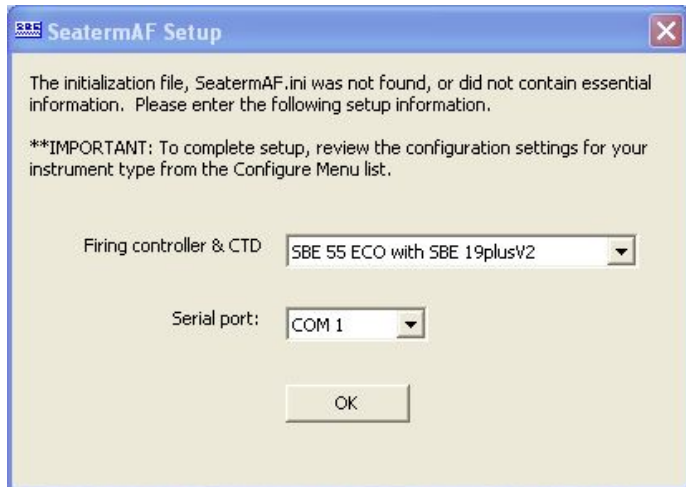

Select the auto fire instrument and CTD (*SBE 55 ECO with SBE 19, SBE 55 ECO with SBE 19plus, SBE 55 ECO with SBE 19plusV2, SBE 55 ECO with SBE 25, SBE 55 ECO with SBE 25plus, or SBE 55 ECO with no CTD*) and serial port for communication with the ECO. Click OK.

2. The main screen looks like this:

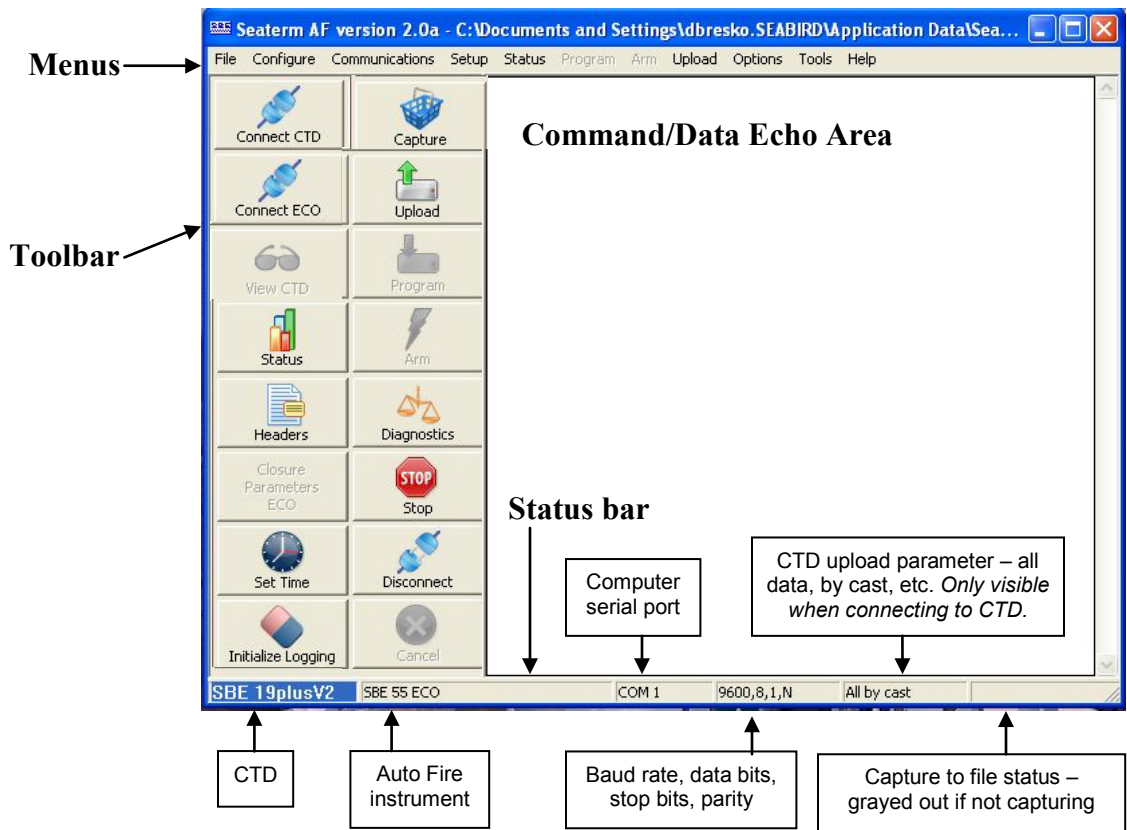

**Note:**

There is at least one way, and as many as three ways, to enter a command:

- Manually type a command in Command/Data Echo Area.
- Use a menu to automatically generate a command.
- Use a Toolbar button to automatically generate a command.

Description of SeatermAF main screen:

- **Menus** – Contains tasks and frequently executed instrument commands.
- **Toolbar** – Contains buttons for frequently executed tasks and instrument commands. Most tasks and commands accessed through the Toolbar are also available in the Menus. Grayed out Toolbar buttons are not applicable. To change the location of the Toolbar (at top or at left), go to the Options menu.
- **Command/Data Echo Area** – Echoes a command executed using a Menu or Toolbar button, as well as the instrument's response. Additionally, a command can be manually typed in this area, from the available commands for the instrument. Note that the instrument must be *awake* for it to respond to a command (use Connect ECO or Connect CTD on the Toolbar to wake up the instrument).
- **Status bar** – Provides status information.

**You must test and set up both the ECO and the CTD. The Status bar indicates which instrument is active by highlighting the active instrument.**

- Menus, toolbar buttons, and manually typed commands associated with the ECO are only applicable when the ECO is *connected* (use Connect ECO on the Toolbar).
- Menus, toolbar buttons, and manually typed commands associated with the CTD are only applicable when the CTD is *connected* (use Connect CTD on the Toolbar).

Following are the Toolbar buttons applicable to the ECO and/or CTD (some apply to both, others apply to only the ECO or only the CTD):

Toolbar Buttons	Description	Equivalent Command*
Connect CTD	Re-establish communications with <b>CTD</b> (SBE 19, <i>19plus</i> , <i>19plus V2</i> , <i>25</i> , <i>25plus</i> ). CTD responds with <i>S&gt;</i> prompt. SBE 19, <i>19plus</i> , <i>19plus V2</i> , <i>25</i> , or <i>25plus</i> goes to sleep after <b>2 minutes</b> without communication from computer have elapsed.	—
Connect ECO	Re-establish communications with <b>ECO</b> . ECO responds with <i>A&gt;</i> prompt. ECO goes to sleep after <b>2 hours</b> without communication from computer have elapsed.	—
View CTD	View data being transmitted from CTD to ECO, to ensure that logging has started before deploying system.	—
Status	Display <b>ECO or CTD</b> instrument status — provide information on instrument setup and current status.	<b>DS</b>
Headers	View SBE 19, <i>19plus</i> , <i>19plus V2</i> , or <i>25</i> <b>CTD</b> data headers (cast number, date and time, number of samples in cast, etc.). A new header is generated for each CTD cast. Note: Headers function is not compatible with SBE <i>25plus</i> .	<b>DH</b>
Closure Parameters ECO	Display all auto fire parameters and auto fire status for <b>ECO</b> .	<b>CP</b>
Set Time	Set <b>ECO or CTD</b> date and time to an accuracy of $\pm 25$ msec of time provided by timekeeping software on your computer (time-keeping software not provided by Sea-Bird). Note: Set Time function is not compatible with SBE 19 or 25; use <b>ST</b> command to set date and time.	SBE <i>19plus</i> : <b>MMDDYY= &amp; HHMMSS=</b> SBE <i>19plus V2</i> or ECO: <b>DateTime=</b>  SBE <i>25plus</i> : <b>SetDateTime=</b>
Initialize Logging	Reset data pointers and cast numbers for SBE 19, <i>19plus</i> , <i>19plus V2</i> , <i>25</i> , or <i>25plus</i> <b>CTD</b> . Initialize logging after existing data has been uploaded from CTD and prior to recording new data.	SBE 19 or 25: <b>IL</b>  SBE <i>19plus</i> , <i>19plus V2</i> , or <i>25plus</i> : <b>InitLogging</b>
Capture	Capture instrument ( <b>ECO or CTD</b> ) responses on screen to file; may be useful for diagnostics. File has .cap extension. Press Capture again to turn off capture. Capture status displays in Status bar.	—
Upload	Upload data from <b>ECO or CTD</b> (SBE 19, <i>19plus</i> , <i>19plus V2</i> , <i>25</i> , or <i>25plus</i> ), in format post-processing software can use. Before using upload: • CTD: Stop logging. • Configure upload and header parameters in Configure menu.	—
Program	Send auto fire information input in Configure menu to <b>ECO</b> . Must send this information before deployment for auto fire capability to function.	—
Arm	Enable <b>ECO's</b> auto fire algorithm to close bottles. Must arm ECO before deployment for auto fire capability to function. ECO will automatically disarm itself and enter the quiescent (sleep) state after <b>24 hours</b> .	<b>Arm</b>
Diagnostics	Perform one or more diagnostic tests on <b>CTD</b> . Diagnostic test(s) accessed in this manner are non-destructive – they do not write over any existing instrument settings. Note: Diagnostics function is not compatible with SBE <i>25plus</i> .	SBE 19 or 25: <b>DS, J, VR, FR</b>  SBE <i>19plus</i> or <i>19plus V2</i> : <b>DS, DCal, TS</b>
Stop	Interrupt ECO's current activity, such as uploading data or performing diagnostic testing.	(press Esc key or Ctrl C)
Disconnect	Free computer serial port used to communicate with <b>ECO or CTD</b> . Serial port can then be used by another program.	—
Cancel	Interrupt SeatermAF's current activity, such as attempting to connect to ECO or programming auto fire.	—

\*See *ECO Command Descriptions* and the applicable CTD manual for detailed command descriptions.

## Testing and Setting Up ECO and CTD

- In the Configure menu, select the SBE 55 ECO with the applicable CTD. The dialog box looks like this for the ECO with SBE 19 (others are similar):

Program setup file contains all instrument settings entered in Configuration Options dialog box. As a default, SeatermAF saves .psa file to last location and with last file name that was used for a particular combination of auto fire instrument and CTD. **You may want to save .psa files with unique names or in unique directories for reuse in future deployments.**

Configuration File – Select .xmlcon or .con file, provided by Sea-Bird (see notes below). File contains pressure coefficients, required for ECO to calculate pressure from raw CTD pressure data. Pressure is used to determine when to close bottles, based on bottle position and closure parameters.

Configuration file can be viewed and modified in SeatermAF by selecting the file (Browse button) and then clicking Modify button. SeatermAF's Configuration dialog box is identical to the one in SBE Data Processing. For details, see SeatermAFHelp.

For **SBE 19plus, 19plus V2, or 25plus**, coefficients are stored in CTD, so configuration file not needed.

Once you select an existing configuration file or create a new one, SeatermAF lists pressure sensor coefficients from configuration file in this area of Setup File tab.

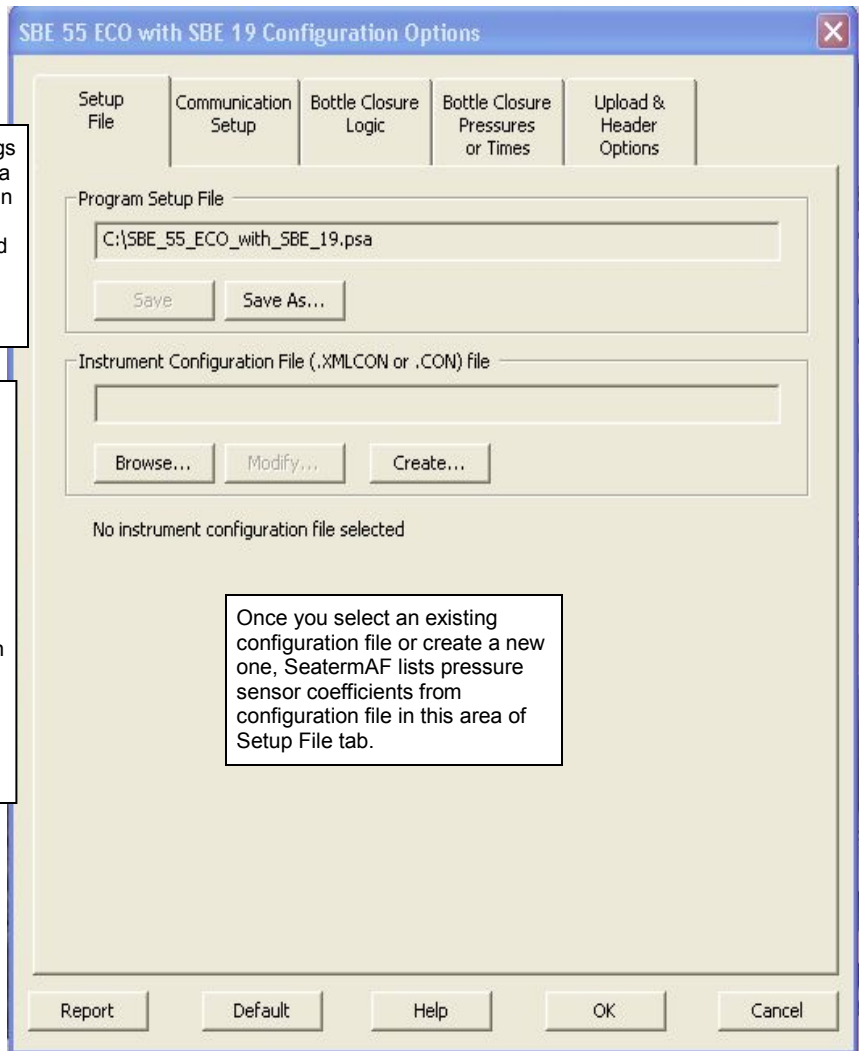

### Notes for SBE 19 and 25:

- Seasave and SBE Data Processing versions 7.20a introduced .xmlcon configuration files (in XML format). **SeatermAF is compatible with both .xmlcon and .con files.**
- The .xmlcon or .con file defines the CTD – integrated auxiliary sensors, and channels, serial numbers, and calibration dates and coefficients for all sensors (conductivity, temperature, pressure, and auxiliary sensors). For the SBE 19 (not 19plus or 19plus V2) and 25 (not 25plus), SeatermAF uses the pressure sensor coefficients to calculate raw pressure sensor output from the user's closure pressure entries in the Configuration Options dialog box. These pressures are used to determine when to close bottles, based on user-input bottle position and closure parameters. **If the configuration file does not match the actual instrument configuration, the ECO will not be able to interpret and process data correctly.**
- A new or recalibrated CTD ships with a configuration file that reflects the current configuration *as we know it*. The file is named with the instrument serial number, followed by a .xmlcon or .con extension. For example, for a CTD with serial number 2375, Sea-Bird names the file *2375.xmlcon*. You may rename the file (but not the extension) if desired; this will not affect the results.
- See the SBE Data Processing manual for setup of the configuration file for the SBE 19 or 25. For use with the ECO, **do not enable NMEA, Surface PAR voltage added, or Scan time added**. These items are only for real-time operation of the CTD, and are not applicable to use with the ECO for autonomous operation.



**Note:**

Only the Communication settings need to be entered to test communications. Bottle Closure Logic, Bottle Closure Pressures or Times, and Upload & Header Options (Steps 5 - 7) are not needed to test communications. These items can be entered now, or can be entered just before deployment, if desired.

4. Click the Communication Setup tab. The dialog box looks like this:

Communication between **ECO and computer:**

- Computer serial port
- Baud rate, data bits, and parity are fixed (4800, 7, even).

Communication between **CTD and computer** (through ECO and ECO data I/O cable) for **setup**:

- **Baud for setup** must match user-programmable baud set in CTD. See CTD manual for command.
- Data bits and parity must match CTD. See CTD manual.
- **Upload baud:** Baud for uploading data in **CTD** memory to computer (through ECO). **Some** CTDs allow a different baud for upload without the need to manually reset the baud rate in the CTD before starting upload.

Communication of real-time pressure data from **CTD to ECO** (required if closing bottles on upcast, downcast, or when stationary).

- **For most CTDs**, must match user-programmable baud rate set in CTD (and set above in this dialog box). See CTD manual for baud command.

The screenshot shows a dialog box titled "SBE 55 ECO with SBE 19 Configuration Options" with a close button in the top right corner. The dialog has five tabs: "Setup File", "Communication Setup", "Bottle Closure Logic", "Bottle Closure Pressures or Times", and "Upload & Header Options". The "Communication Setup" tab is selected. The dialog is divided into three sections:

- Communications between computer and SBE 55:**
  - Serial port: COM 1 (dropdown)
  - Data bits: 7 (dropdown)
  - Baud rate: 4800 (dropdown)
  - Parity: Even (dropdown)
- Communications between computer and CTD through SBE 55:**
  - Baud rate: 600 (dropdown)
  - Data bits: 7 (dropdown)
  - Upload baud rate: 19200 (dropdown)
  - Parity: Even (dropdown)
  - Text below: "Upload baud rate not applicable if 'Firmware version < 3.0' selected in .XMLCON or .CON file on 'Setup File' tab."
- Communication of pressure data from CTD to SBE 55:**
  - Real-time baud rate: 9600 (dropdown)
  - Text below: "Not applicable if 'Close on elapsed time, do not record CTD data' selected on 'SBE 55 Bottle Closure Logic' tab."

At the bottom of the dialog are five buttons: "Report", "Default", "Help", "OK", and "Cancel".

**Note:**  
See *Bottle Closure Setup Parameters* below for details and examples of each of the bottle closure options.

5. Click the Bottle Closure Logic tab. The dialog box looks like this if *Close on upcast* is selected:

Bottle closure logic.

If *Close on downcast* or *Close on upcast* - defines when bottom is reached and upcast begins.

If *Close when stationary* - defines when CTD is considered stationary, signaling ECO to close bottle.

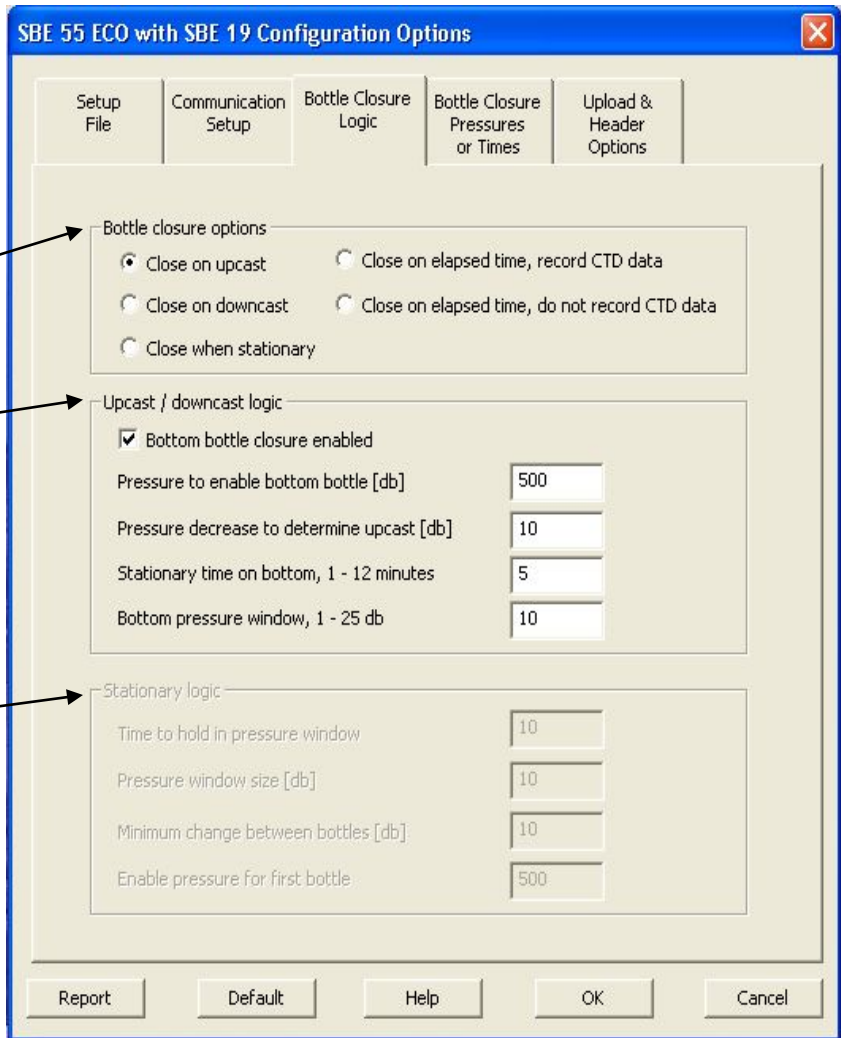

**Note:**  
See *Bottle Closure Setup Parameters* below for details and examples of each of the bottle closure options.

6. Click the Bottle Closure Pressures or Times tab. The dialog box looks like this if *Close on upcast* was selected:

Total number of bottles to close during deployment.

Bottles may be closed in any order desired. For this example, bottom bottle closure was enabled on Bottle Closure Logic tab, so closure 1 is for bottom bottle.

Closure order	Bottle position	Closure pressure[db]
Bottom bottle	1	stationary
2	3	400
3	5	300
4	2	200
5	4	100
6	6	10

Closure pressures must decrease from closure 1 to last bottle.

Closure pressures for closure on upcast or downcast, **or** closure times (elapsed minutes since ECO was armed) for closure on elapsed time.

- Closure on upcast - pressures must **decrease** from closure 1 to last closure
- Closure on downcast - pressures must **increase** from closure 1 to last closure
- Closure on elapsed time - elapsed times must **increase** from closure 1 to last closure

**Note:**

**SBE 25plus:** Upload and Header options for the CTD data do not appear in this dialog box.

- Click the Upload & Header Options tab. The dialog box looks like this:

Data upload type from **CTD** memory (through ECO) when using Upload on Toolbar or Upload menu:

- All data separated by cast - All data uploaded. Separate file written for each cast, with 3-digit cast ID (001, etc.) appended to user-selected file name.
- Single cast - SeatermAF prompts for cast number, and uploads all data from cast.
- By cast number range - SeatermAF prompts for beginning and ending cast numbers, and uploads data within that range. Separate file written for each cast, with 3-digit cast ID (001, etc.) appended to user-selected file name.
- All data as a single file – All data uploaded into 1 file.
- By scan number range – SeatermAF prompts for beginning and ending scan (sample) numbers, and uploads all data within range into 1 file.

Defines header information included with uploaded data from **CTD** or **ECO** memory, as applicable:

- Prompt for header information** (default) – Each time data is uploaded, user is prompted to fill out user-defined header form.
- Include default header form in upload file** – User-defined default header form included in upload file. User is not prompted to add any information when data is uploaded.
- Do not include default header form in upload file** – Header information not included in upload file.

SeatermAF uploads CTD data in *blocks*, and calculates a checksum at the end of each block. If the block fails the checksum verification, SeatermAF tries to upload the block of data again, cutting the block size in half. For most CTDs, the default block size is 250 scans (samples).

**Notes:**

When exiting the program, SeatermAF prompts you to save the instrument settings to the .psa file if they have been modified. Alternatively, to save the settings to the .psa file while still in the Configuration Options dialog box, click on the Setup File tab and click Save or Save As.

- Click OK to temporarily save the settings in the Configuration Options dialog box and to exit the dialog box.

- Click Connect ECO on the Toolbar. The display looks like this:

A>

This shows that correct communications between the computer and ECO have been established.

If the ECO does not respond as shown above:

- Click Connect ECO again.
- Verify the correct auto fire instrument was selected in the Configure menu and the communication settings were entered correctly on the Communication Setup tab in the Configuration Options dialog box.
- Check cabling between the computer and ECO.
- Check the ECO battery voltage - see *Replacing/Recharging Batteries* in Section 8: Routine Maintenance.

**Notes:**

- The ECO has a 2-hour timeout algorithm designed to conserve battery energy if too much time elapses between commands. If the ECO does not appear to respond, click Connect ECO on the Toolbar to reestablish communications.
- The ECO turns off power when voltage drops below 7.5 volts.
- Lithium battery: Replacing the back-up lithium battery is difficult and delicate; we recommend that you return the Electronic Control Module to Sea-Bird if it needs to be replaced. If you keep the ECO powered with the main alkaline batteries, the ECO can continue to operate with a low lithium battery voltage (the primary purpose of the lithium battery is to maintain the real-time clock and to allow for an orderly shut down of the unit if the alkaline batteries fail, but the alkaline batteries can maintain the real-time clock if the lithium voltage is too low).

10. Display ECO status information by clicking Status on the Toolbar. The display looks like this:

```
SBE 55 V 1.3 15 Dec 2012 16:40:11
main battery = 11.86 volts
lithium battery = 2.92 volts
SBE 55 is NOT ARMED
```

Looking at the status display, verify the following:

- Main battery voltage is sufficient (> 7.5 volts) - If not, replace/recharge the batteries before proceeding (see *Replacing/Recharging Batteries* in *Section 8: Routine Maintenance*).
  - Lithium battery voltage is sufficient (> 2.25 volts) – If not, replace the lithium battery (see note).
  - Date and time are correct - If not, type **DateTime=mmddyyhhmmss** (mm=month, dd=day, yyyy=year, hh=hour, mm=minutes, ss=seconds) and press the Enter key. Click Status on the Toolbar again to verify that the ECO accepted the new date and time.
  - SBE 55 is not armed - If it is armed, type **DA** (disarm) and press the Enter key before proceeding. The ECO must be disarmed before it accepts the bottle closure information you input in the Configuration Options dialog box.
11. Click Program on the Toolbar to send all the bottle closure information from the Configuration Options dialog box to the ECO. SeatermAF sends a number of commands to the ECO, transmitting the bottle closure parameters in the format required by the ECO.

12. Click Connect CTD on the Toolbar. The display looks like this:

```
Connected successfully . . .
S>
```

This shows that correct communications between the computer and CTD (through the ECO) have been established.

If the CTD does not respond as shown above:

- Click Connect CTD again.
  - Verify the correct CTD was selected in the Configure menu and the CTD communication settings were entered correctly on the Communication Setup tab in the Configuration Options dialog box.
  - Check cabling between the computer, ECO, and CTD.
  - Check the CTD battery voltage.
13. (All except SBE 25*plus*) Display CTD status information by clicking Status on the Toolbar.
14. (SBE 25*plus*) Display configuration and status information by sending **GetCD** and **GetSD** commands.
15. Review the information in the status display. As desired, send commands to the CTD to change the instrument setup (see CTD manual).

**Notes:**

- **SBE 25:** If closing bottles on upcast, verify that the SBE 25 configuration entered with **CC** is *Stop CTD on upcast (y/n)? = NO*.
- **SBE 19*plus* or 19*plus* V2:** SeatermAF automatically sets **OutputFormat=4** in the CTD when you program the ECO (Program on Toolbar or Program menu). This is required for real-time communication of pressure to the ECO.
- **SBE 25*plus*:** SeatermAF automatically sets **SetOutputFormat=1** when you program the ECO (Program on Toolbar or Program menu). This is required for real-time communication of pressure to the ECO.

## Bottle Closure Setup Parameters

**Notes:**

- After entering and saving information in the Configuration Options dialog box, you must *program* the ECO to send the bottle closure information to the ECO. With the ECO *connected*, click Program on the Toolbar; SeatermAF sends a number of commands to the ECO, transmitting the required information.
- A new or recalibrated CTD ships with a configuration file that reflects the current configuration as *we know it*. The file is named with the instrument serial number, followed by a .xmlcon or .con extension. For example, for a CTD with serial number 2375, Sea-Bird names the file *2375.xmlcon*. You may rename the file (but not the extension) if desired; this will not affect the results.

The ECO closes bottles on upcast, on downcast, when stationary, or based on elapsed time. Descriptions of each closure type follow.



### Close on Upcast

If you select *Close on upcast* on the Bottle Closure Logic tab, the ECO closes bottles on upcast only; it does not begin to close bottles until it determines that upcast has begun. Upcast/Downcast Logic parameters define the conditions of pressure and time that indicate that the bottom has been reached and upcast has begun.

**Note:**  
**SBE 25:** If you want to close bottles on upcast, verify that the SBE 25 configuration entered with **CC** is *Stop CTD on upcast (y/n)? = NO*.

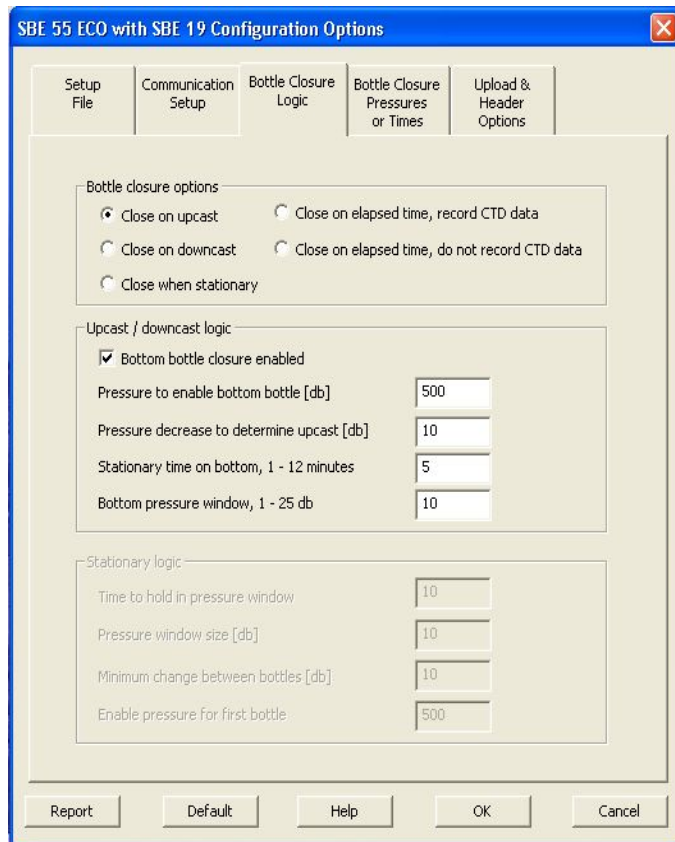

#### Bottom Bottle Closure not Enabled

Upcast is enabled (has begun) when the pressure is greater than *Minimum pressure to determine upcast* **and** the pressure decreases more than *Pressure decrease to determine upcast*. The ECO does not close a *bottom* bottle when upcast is enabled.

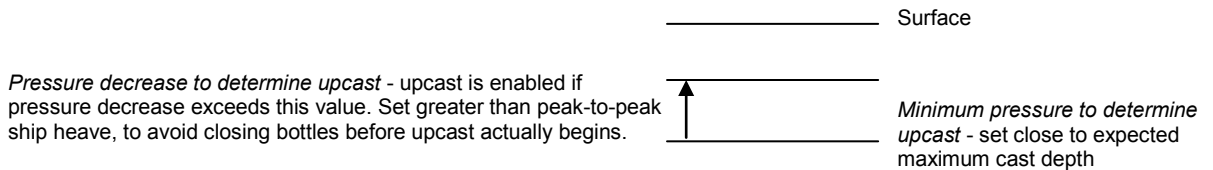

#### Bottom Bottle Closure Enabled

Upcast is enabled **and** the bottom bottle closes when the ECO determines that the bottom of the cast has been reached. The ECO enables upcast when the pressure is at least *Pressure to enable bottom bottle*, **and**

- the pressure remains within *Bottom pressure window* for *Stationary time on bottom*, **or**
- the pressure decreases by *Pressure decrease to determine upcast*.

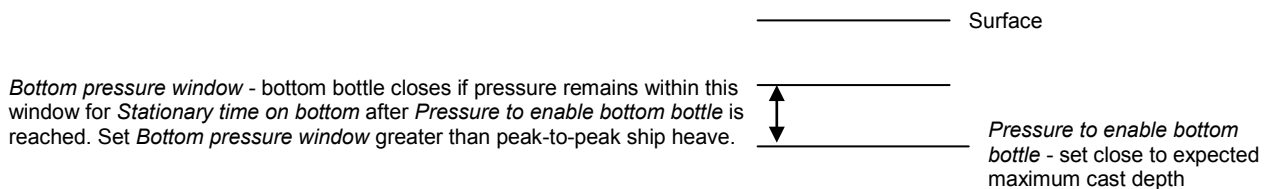

The Bottle Closure Pressures or Times tab defines the number of bottles to close, closure order, and closure pressures.

Total number of bottles to close during deployment.

Bottles may be closed in any order desired. **For closure on upcast, closure pressure must decrease from closure 1 to last closure.** For this example, bottom bottle closure was enabled on Bottle Closure Logic tab, so closure 1 is for bottom bottle.

Closure order	Bottle position	Closure pressure[db]
Bottom bottle	1	stationary
2	3	400
3	5	300
4	2	200
5	4	100
6	6	10

Closure pressures must decrease from closure 1 to last bottle.

### Close on Downcast

If you select *Close on downcast* on the Bottle Closure Logic tab, the ECO closes bottles on downcast only. Upcast/Downcast Logic parameters define the conditions of pressure and time that indicate that the bottom has been reached and upcast has begun, allowing closure of a *bottom* bottle if desired.

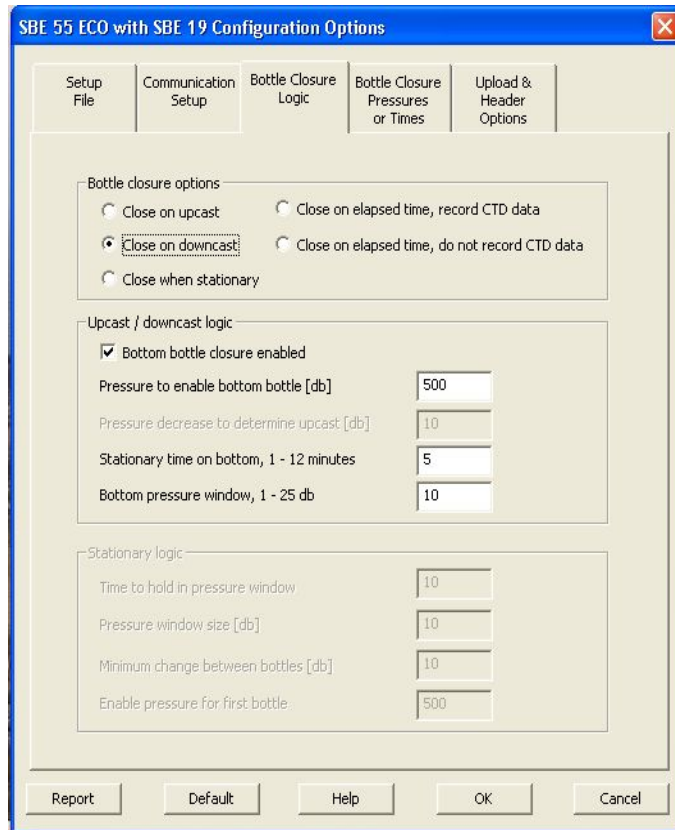

#### **Bottom Bottle Closure not Enabled**

The Upcast/Downcast Logic parameters are not applicable.

#### **Bottom Bottle Closure Enabled**

The bottom bottle closes when the ECO determines that the bottom of the cast has been reached. This occurs when the pressure is at least *Pressure to enable bottom bottle*, **and** the pressure remains within *Bottom pressure window* for *Stationary time on bottom*.

————— Surface

*Bottom Pressure Window* - bottom bottle closes if pressure remains within this window for *Stationary time on bottom* after *Pressure to enable bottom bottle* is reached. Set *Bottom pressure window* greater than peak-to-peak ship heave.

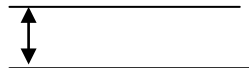

*Pressure to enable bottom bottle* - set close to expected maximum cast depth

The Bottle Closure Pressures or Times tab defines the number of bottles to close, closure order, and closure pressures.

Total number of bottles to close during deployment.

Bottles may be closed in any order desired. **For closure on downcast, closure pressure must increase from closure 1 to last closure.** For this example, bottom bottle closure was enabled on Bottle Closure Logic tab, so closure 12 is for bottom bottle.

Closure order	Bottle position	Closure pressure[db]
1	1	10
2	3	50
3	5	100
4	2	200
5	4	300
Bottom bottle	6	stationary

## Close when Stationary

If you select *Close when stationary* on the Bottle Closure Logic tab, Stationary Logic parameters define when the CTD is considered stationary, signaling the ECO to close a bottle. The ECO closes bottles **on upcast** when using stationary logic.

### Note:

If *Minimum change between bottles* is 0 (i.e., you **want** to close all bottles at the same pressure), there is a delay between each bottle closing to ensure the ECO has enough time to acquire five scans of CTD data. The delay is approximately:

- SBE 19, 19*plus*, or 19*plus* V2: 1.5 sec
- SBE 25 or 25*plus*: 1 sec

- Once the CTD reaches *Enable pressure for first bottle*, a bottle is closed each time the pressure remains within *Pressure window size* for *Time to hold in pressure window*.
- *Minimum change between bottles* is the minimum pressure change between two consecutive bottles to enable the next bottle closing. This prevents the ECO from closing multiple bottles at approximately the same pressure.

The Bottle Closure Pressures or Times tab defines the number of bottles to close and the bottle closure sequence.

Total number of bottles to close during deployment.

Bottles may be closed in any order desired.

Closure order	Bottle position	Closed when stationary
1	1	stationary
2	3	stationary
3	5	stationary
4	2	stationary
5	4	stationary
6	6	stationary

## Close on Elapsed Time - Record or Do Not Record CTD Data

**Note:**

If you selected *ECO with no CTD* in the Configure menu, the Bottle Closure Logic tab is grayed out, because bottle closure logic is automatically set to *Close on elapsed time, do not record CTD data*.

If you select *Close on elapsed time* on the Bottle Closure Logic tab, the ECO closes bottles based on the elapsed time from when the ECO is armed (by clicking Arm on Toolbar, selecting the Arm menu, or sending **Arm** from keyboard).

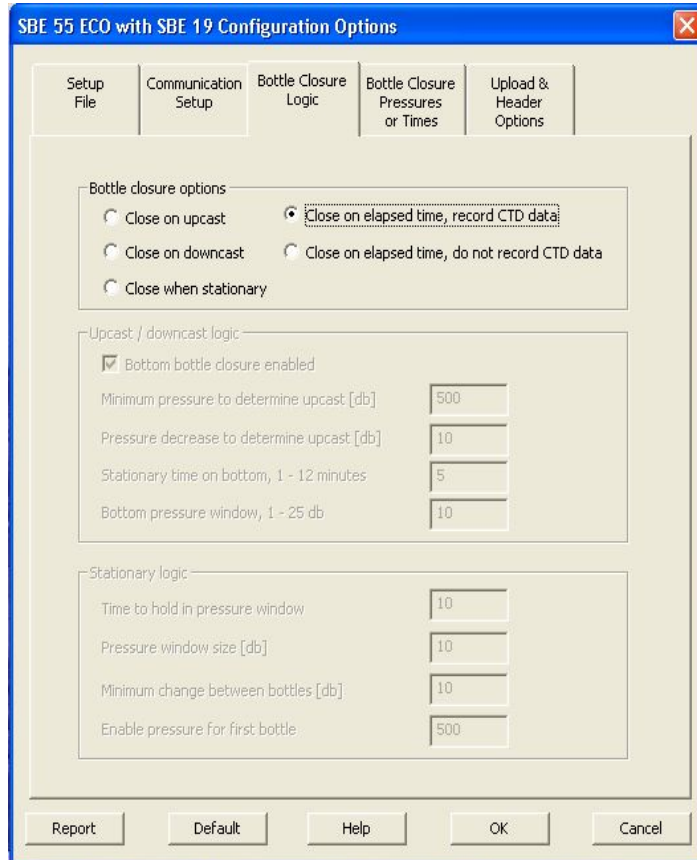

- Close on elapsed time, **record CTD data** - The ECO records 5 scans of CTD data each time a bottle is closed, to provide a CTD record for each water sample.
- Close on elapsed time, **do not record CTD data** - The ECO does not record any CTD data. This option is most often used for an ECO operating without a CTD.



The Bottle Closure Pressures or Times tab defines the number of bottles to close, closure sequence, and elapsed time for each bottle.

**SBE 55 ECO with SBE 19 Configuration Options**

Setup File | Communication Setup | **Bottle Closure Logic** | **Bottle Closure Pressures or Times** | Upload & Header Options

Total number of bottles to close during deployment. →

Number of Bottles to Close: 6

Closure order	Bottle position	Elapsed time since Arm [min]
1	1	10
2	3	14
3	5	18
4	2	22
5	4	26
6	6	30

Bottles may be closed in any order desired. **Elapsed time must increase from closure 1 to last closure.**

Elapsed time must increase from closure 1 to last bottle.

Report | Default | Help | OK | Cancel

## Command Descriptions

### Notes:

- When connected to the **ECO**, SeatermAF displays an A> prompt. When connected to the **CTD through the ECO**, SeatermAF displays an S> prompt.
- For CTD command descriptions, see the applicable CTD manual.

When entering commands for the **ECO**:

- **Verify that the computer is talking to the ECO, not the CTD** (check the left side of the status bar at the bottom of SeatermAF's window). If it is not, click Connect ECO on the Toolbar.
- Input commands to the ECO in upper or lower case letters and register commands by pressing the Enter key.
- The ECO sends `invalid command` if an invalid command is entered.
- If the ECO does not return an A> prompt after executing a command, press the Enter key to get the A> prompt.
- If a new command is not received within 2 hours after completion of a command, the Command/Data Echo Area indicates **time out** and the ECO returns to quiescent (sleep) state to prevent battery exhaustion.
- If in quiescent state, re-establish communications by clicking Connect ECO on the Toolbar to get an A> prompt.

---

### Status Commands

---

#### GetSD

Display operating status. List below includes, where applicable, command used to modify parameter:

- firmware version, date and time [Date Time=]
- main battery voltage
- back-up lithium battery voltage
- ECO armed status [Arm or DA]

Equivalent to Status on Toolbar.

*Example:* (user input in bold)

A>**getsd**

SBE 55 V 1.3 15 Feb 2013 16:40:11

[Date Time=]

main battery = 11.86 volts

lithium battery = 2.92 volts

SBE 55 is NOT ARMED

[DA]

or

A>**getsd**

ARMED

[Arm]

**DS**

Same as **GetSD**.

**Status Commands** *(continued)***DC**

Display bottle closure parameters.

- CTD type and firmware revision  
(note: SBE 19*plus* applies to 19*plus*, 19*plus* V2, or 25*plus*)
- CTD pressure sensor polarity
- CTD baud rate
- number of bottles to fire
- bottle closure sequence  
(Note: first bottle position is '0')
- bottle closure pressures
- bottle closure elapsed times
- closure mode - downcast, upcast, stationary, elapsed time with no CTD data, elapsed time with CTD data
- upcast/downcast logic - bottom bottle enabled, pressure to enable upcast, pressure change to enable upcast, stationary time on bottom, bottom pressure window
- stationary logic - minimum time to hold in pressure window to enable bottle closure, pressure window size, minimum change in pressure between bottles to enable next bottle closing, enable pressure for first bottle

**Note:**

The response to **DC** includes upcast/downcast logic, stationary logic, and bottle closure pressures and times. However, the *fire mode* (downcast, upcast, stationary, elapsed time) defines which of these parameters is actually applicable to the ECO's operation (for example, stationary logic and bottle closure elapsed times are irrelevant and not used if the fire mode is to close on upcast).

Equivalent to Closure Parameters ECO on Toolbar.

*Example:* (user input in bold).

```
A>>DC
CTD type = SBE 25, firmware >= 2.0
pressure sensor type = negative
CTD baud rate = 9600
number of bottles to fire = 6
bottle fire order = 0 ,1 ,2 ,3 ,4 ,5
bottle pressures = -3532 , -3595 , -3658 , -3721 , -3784 , -3847
bottle times = 5 ,10 ,15 ,6 ,7 ,10
fire mode = close on upcast
upcast / downcast logic:
  bottom bottle closure disabled
  pressure to enable upcast = -3490
  pressure change to enable upcast = 21
  stationary time on bottom = 5
  bottom pressure window = 21
stationary logic:
  time to hold in pressure window = 1
  pressure window size = 50
  min change between bottles = 101
  enable pressure for first bottle = -2576
```

**GetHD**

Display ECO hardware data (factory set).

*Example:* (user input in bold).

```
A>>gethd
SBE 55 V 1.3
SBE 55 FirmwareLoader V 1.0
```

---

**Status Commands** *(continued)*

---

**GetEC** Transmit list of *events* and number of times they occurred. Events can be unexpected conditions which should be interpreted as errors as well as device power-up, invalid commands, or low-battery conditions.

*Example:* (user input in bold).

```
A>getec
number of events = 0
```

**ResetEC** Clear event counters to 0.

---

**Date and Time Commands**

---

**Note:**

If the ECO battery has been removed, date and time must be reset.

**DateTime=x** x= real-time clock date and time (mmddyyyyhhmmss).

*Example:* Set date and time to 10 August 2013 12:15:33 (user input in bold).  
A>**datetime=08102013121533**

---

**Auto Fire: Arm/Disarm Commands**

---

Arm before deploying to enable the ECO to take water samples. Disarm to disable the ECO from taking water samples; the CTD (SBE 19, *19plus*, *19plus V2*, *25*, or *25plus*) can still log data.

**Arm** Arm (enable) auto fire to close bottles. ECO automatically disarms after 24 hours. Equivalent to Arm on Toolbar.

**DA** Disarm (disable) auto fire to close bottles.

**Notes:**

- **Use Upload on the Toolbar or the Upload menu to upload data that will be processed by SBE Data Processing.** Manually entering the data upload command does not produce data with the required header information for processing by our software. These commands are included here for reference for users who are writing their own software.
- To save data to a file, click Capture on the Toolbar before entering **DD**.
- See *ECO Data Formats* below.

---

**Data Upload Command**

---

Stop CTD logging/sampling before uploading data.

**DD** Upload raw data from **ECO**. For each bottle fired:

- Bottle sequence and number, date and time, firing confirmation, battery voltage, scan number of first of 5 CTD scans, and 5 scans of CTD data, or
- (if used without a CTD) Bottle sequence and number, date and time, firing confirmation, and battery voltage.

---

**Sleep Command**

---

**Note:**

ECO automatically goes to sleep if 2 hours elapse without receipt of a command.

**QS**

Quit session and place ECO in quiescent (sleep) state. Main power is turned off. Memory retention is unaffected.

---

**Testing Commands**

---

Test before arming and deploying the system to verify that the ECO is operating properly. Before testing, cock the release mechanisms by pushing against each trigger until it clicks and locks in place (see *Rigging and Cocking Lanyards* in *Section 3: Mechanically Preparing ECO for Deployment*).

**DCDCOn**

Turn on power to ECO for testing purposes; used to charge ECO storage capacitor prior to firing. Wait for 1 minute after sending **DCDCOn** before test firing a bottle.

**DCDCOff**

Turn off power to ECO when testing is complete. If you do not send this command, ECO automatically turns off power after 2 hours.

**FireX**

x= bottle number (1, 2, 3, 4, 5, or 6) to fire for testing purposes. ECO replies *fire confirmed* or *no confirm*.

**WARNING!**

If testing the ECO with lanyards rigged on the bottles and attached to the latches: **bottles close rapidly and with great force, which can cause injury**. Verify no one is near the ECO before beginning testing.

If **DCDCOn** was not sent before this command, ECO replies *wait 10 seconds for capacitor to charge* and then fires bottle after 10 sec. However, you may not get a fire confirmed reply when operating this way.

*Example:* Test bottles 1 through 3 (user input in bold).

```
A>dcdcon
A>fire1
A>fire2
A>fire3
A>dcdcoff
```

**\*EETest**

Test ECO EEPROM.

## Commands Not Typically Sent by User

The user does not typically send the remaining commands, which are included here for reference only. These involve setting up auto fire parameters, which are more easily set up in the Configuration Options dialog box (select the SBE 55 with the applicable CTD in the Configure menu). SeatermAF automatically sends many of these commands (with **calculated** values based on entries in the dialog box) to the ECO when the user clicks on the Toolbar's Program button. **Sea-Bird highly recommends using the Configuration Options dialog box to set up the ECO** instead of using these commands.

---

### General Setup Commands

---

<b>ITx</b>	Select CTD: <b>x=0</b> : SBE 19. <b>x=1</b> : SBE 25 with firmware version < 2.0. <b>x=2</b> : SBE 25 with firmware version $\geq$ 2.0. <b>x=3</b> : SBE 19 <i>plus</i> , 19 <i>plus</i> V2, or 25 <i>plus</i> .
<b>BRx</b>	$x = 76800 / (\text{CTD real-time data baud rate})$ (see CTD configuration sheet for baud).

---

### Auto Fire: *General Setup* Commands

---

<b>BLx</b>	Set bottle closure logic: <b>x=0</b> : Close on downcast. <b>x=1</b> : Close on upcast. <b>x=2</b> : Close on elapsed time, and do not record CTD data in ECO. <b>x=3</b> : Close when stationary. <b>x=4</b> : Close on elapsed time, and record CTD data in ECO.
<b>BNx</b>	$x =$ total number of bottles to be closed.
<b>BAnm</b>	ECO allows bottles to be fired out of numerical sequence. Bottle closure <b>n</b> closes bottle number <b>m</b> . Repeat for each bottle.

#### Notes:

- n = sequence, single character = (sequence number - 1) + '0'
- m = bottle number, single character = (bottle number - 1) + '0'
- t = time in minutes, long integer value between 0 and 2,147,483,648
- p = raw pressure sensor pressure number, integer value between -4095 and +4095. SeatermAF computes p using the calibration coefficients in the specified configuration (.con) file.

**Note:**

PTx applies only to the SBE 19 and 25.

**Auto Fire: *General Setup* Commands (continued)**

<b>PTx</b>	Select pressure polarity (see configuration sheet for CTD - SBE 19 or SBE 25 - used with ECO): <b>x=0</b> : Negative polarity (increasing pressures give decreasing pressure numbers) <b>x=1</b> : Positive polarity (increasing pressures give increasing pressure numbers)
------------	--

**Auto Fire: *Downcast and Upcast Logic Setup* Commands**

These commands set up closure parameters for closure on downcast or upcast (applicable if **BL0** or **BL1** was sent)

<b>BBx</b>	<b>x=Y</b> : Enable bottom bottle closure - close a bottle when pressure remains within <b>BBP</b> for <b>BBT</b> . <b>x=N</b> : Disable bottom bottle closure.
<b>BBPp</b>	<b>p</b> = bottom bottle pressure window size.
<b>BBTt</b>	<b>t</b> = bottom bottle time.
<b>BUPp</b>	<b>p</b> = pressure to signal upcast.
<b>BUDp</b>	<b>p</b> = pressure decrease from maximum to signal upcast.
<b>PAnp</b>	Perform bottle closure <b>n</b> at pressure <b>p</b> . Repeat for each bottle.

**Auto Fire: *Time-Based Logic Setup* Commands**

These commands set up closure parameters for closure based on elapsed time (applicable if **BL2** or **BL4** was sent).

<b>TAnt</b>	Perform bottle closure <b>n</b> at elapsed time <b>t</b> . Repeat for each bottle.
-------------	---

**Auto Fire: *Stationary Logic Setup* Commands**

These commands set up closure parameters for closure based on elapsed time (applicable if **BL3** was sent).

<b>BSTt</b>	<b>t</b> = time to hold in pressure window.
<b>BSPp</b>	<b>p</b> = pressure window size.
<b>BSGp</b>	<b>p</b> = change in pressure to switch from stop to go.
<b>BSMp</b>	<b>p</b> = minimum pressure to enable first bottle.



## Wiring System

### Note:

See *Dimensions and Connectors and Cables and Wiring* in Section 2: *Description of ECO* for connector pin outs and cable wiring diagrams.

- Connect the ECO's 6-pin *Instrument* connector (**counter-clockwise** from 2-pin *Sea Cable* connector on Electronics Control Module) to the CTD. **Note:** SBE 19 and 25 CTDs configured with a pump, and all SBE 19*plus* V2 and 25*plus* CTDs, have a 6-pin data I/O – pump connector. These CTDs are supplied with a Y-cable (6-pin to CTD, 4-pin data I/O, 2-pin pump); connect the ECO to the 4-pin data I/O connector on the Y-cable.
- The ECO's Electronics Control Module has two 4-pin *Latch Array* connectors, each controlling one latch assembly (3 bottles per latch assembly). Connect each of the 4-pin *Latch Array* connectors to the connector on a latch assembly.

See the CTD manual for connections to auxiliary sensors.

## Deploying System

### Notes:

- **Upload existing data from the ECO before redeploying.** On redeployment, the ECO overwrites any data in its memory.
- The ECO automatically disarms itself after 24 hours.
- **SBE 19*plus* or 19*plus* V2:** SeatermAF automatically sets **OutputFormat=4** in the CTD when you program the ECO (Program on Toolbar or Program menu). This is required for real-time communication of pressure to the ECO.
- **SBE 25*plus*:** SeatermAF automatically sets **SetOutputFormat=1** in the CTD when you program the AFM (Program on Toolbar or Program menu). This is required for real-time communication of pressure to the ECO.

1. Double click on SeatermAF.exe. The main screen appears.
2. Ready the **ECO** for deployment by programming and arming it:
  - A. In the File menu, select Open Setup File. In the dialog box, select the previously saved settings (.psa) file and click Open.
  - B. Click Connect ECO on the Toolbar to establish communications with the **ECO**.
  - C. Click Program on the Toolbar, sending the input closure parameters to the **ECO**.
  - D. Click Arm on the Toolbar, enabling the **ECO** to close bottles.
3. Ready the **CTD** for deployment:
  - A. Click Connect CTD on the Toolbar to establish communications with the **CTD**.
4. Deployment **starting the CTD with its switch:**
  - A. Verify the CTD's switch is in the Off position.
  - B. Send **QS** to put the CTD in quiescent (sleep) state.
  - C. Turn on the CTD's switch to start logging. Data will be recorded after existing data in the CTD.
  - D. If desired, click View CTD on the Toolbar to view the data being transmitted from the CTD to the ECO, to ensure that logging has started. Verify that pressure numbers from each CTD scan are displaying on the screen (see the CTD manual for data format details).
    - **SBE 19 or 25:** displayed pressures are raw values. For SBE 19, the first pressure number is not displayed until reference scans are received.
    - **SBE 19*plus* or 19*plus* V2:** ECO automatically set CTD to **OutputFormat=4**; displayed pressures are decibars.
    - **SBE 25*plus*:** ECO automatically set 25*plus* to **SetOutputFormat=1**; displayed pressures are decibars.
  - E. Exit SeatermAF.
  - F. Disconnect the I/O cable from the **ECO's** 6-pin to 4-pin extender cable. Place a dummy plug and locking sleeve on the end of the extender cable (see Step 6).

5. Deployment **starting the CTD with a computer command:**

- A. Start sampling/logging -
  - SBE 19 or 25: Turn on the CTD's switch, and then send **GL** (overwrite existing data in CTD) or **RL** (do not overwrite existing data in CTD).
  - SBE *19plus*, *19plus V2*, or *25plus*: Send **StartNow** (do not overwrite existing data in CTD).
- B. If desired, click View CTD on the Toolbar to view the data being transmitted from the CTD to the AFM, to ensure that logging has started. Verify that pressure numbers from each CTD scan are displaying on the screen (see the CTD manual for data format details).
  - **SBE 19 or 25:** displayed pressures are raw values. For SBE 19, the first pressure number is not displayed until reference scans are received.
  - **SBE *19plus* or *19plus V2*:** ECO automatically set CTD to **OutputFormat=4**; displayed pressures are decibars.
  - **SBE *25plus*:** ECO automatically set *25plus* to **SetOutputFormat=1**; displayed pressures are decibars.
- C. Exit SeatermAF.
- D. Disconnect the I/O cable from the **ECO's** 6-pin to 4-pin extender cable. Place a dummy plug and locking sleeve on the end of the extender cable (see Step 6)

**CAUTION:**

**Do not use WD-40** or other petroleum-based lubricants, as they will damage the connectors.

## 6. Verify that a cable connector or dummy plug is installed for every connector on the ECO and CTD:

- A. Lightly lubricate the inside of the cable connector or dummy plug with silicone grease (DC-4 or equivalent).
- B. **Standard Connector** - Install the cable connector/plug, aligning the raised bump on the side of the connector/plug with the large pin (pin 1 - ground) on the instrument. Remove any trapped air by burping or gently squeezing the connector/plug near the top and moving your fingers toward the end cap. **OR**  
**MCBH Connector** – Install the cable connector/plug, aligning the pins.
- C. Place the locking sleeve over the connector/plug. Tighten the locking sleeve finger tight only. Do not overtighten the locking sleeve and do not use a wrench or pliers.

## 7. Verify that the hardware and external fittings are secure.

## 8. Deploy the system.

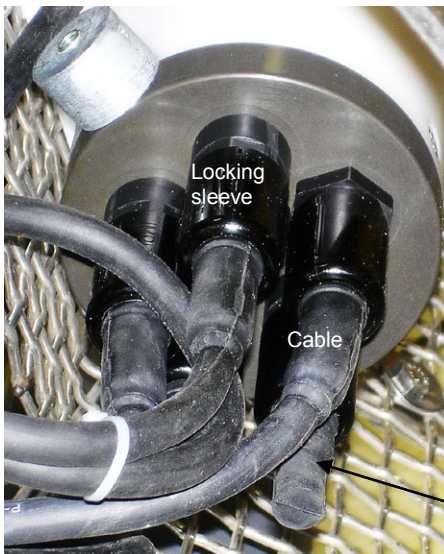

Dummy plug

Electronics Control Module shown; verify dummy plug or cable installed for every connector on ECO and CTD

## Recovery

**WARNING!**

**If the ECO, CTD, or auxiliary equipment/sensors stop working while underwater, are unresponsive to commands, or show other signs of flooding or damage, carefully secure the instrument away from people until you have determined that abnormal internal pressure does not exist or has been relieved.**

Pressure housings may flood under pressure due to dirty or damaged o-rings, or other failed seals. When a sealed pressure housing floods at great depths and is subsequently raised to the surface, water may be trapped at the pressure at which it entered the housing, presenting a danger if the housing is opened before relieving the internal pressure.

Instances of such flooding are rare. However, a housing that floods at 600 meters depth holds an internal pressure of more than 800 psia, and has the potential to eject the end cap with lethal force. A housing that floods at 50 meters holds an internal pressure of more than 85 psia; this force could still cause injury.

If you suspect the ECO's Electronics Control Module is flooded, point the Electronics Control Module in a safe direction away from people, and loosen 1 end cap bulkhead connector very slowly, at least 1 turn. This opens an o-ring seal under the connector. Look for signs of internal pressure (hissing or water leak). If internal pressure is detected, let it bleed off slowly past the connector o-ring. Then, you can safely remove the end cap.

## Physical Handling

Rinse the ECO, CTD, and auxiliary equipment and sensors with fresh water, and dry thoroughly.

## Uploading Data

### Prepare to Upload Data

**Note:**

**You must upload data from the ECO before redeploying.** On redeployment, the ECO overwrites any data in its memory.

1. If you have not already done so, stop CTD logging/sampling:
  - **SBE 19 or 25:** Move the switch to the Off position.
  - **SBE 19plus or 19plus V2:**  
Move the switch to the Off position. **OR**  
If set up to start and stop logging on command and ignore the switch position - connect the ECO to the computer, establish communications with the CTD through the ECO, and send **Stop** to stop logging.
  - **SBE 25plus:**  
Move the switch to the Off position. **OR**  
Connect the AFM to the computer, establish communications with the CTD through the AFM, and send **Stop** to stop logging.
2. If you have not already done so, connect the ECO to the computer:
  - A. By hand, unscrew the locking sleeve from the ECO's 6-pin to 4-pin data I/O cable extender. **If you must use a wrench or pliers, be careful not to loosen the bulkhead connector instead of the locking sleeve.**
  - B. Remove the dummy plug from the cable extender by pulling the plug firmly away from the connector.
  - C. **Standard Connector** - Install the 4-pin to 9-pin DB-9S cable (with blue tape on both ends), aligning the raised bump on the side of the connector with the large pin (pin 1 - ground) on the cable extender.  
**OR**  
**MCBH Connector** – Install the 4-pin to 9-pin DB-9S cable (with blue tape on both ends), aligning the pins.
  - D. Connect the I/O cable connector to your computer's serial port.
3. In SeatermAF's File menu, select Open Setup File. In the dialog box, select the setup (.psa) file you previously saved and click Open.

**Notes:**

- Set up Upload & Header options for the ECO and CTD (Step 4) the first time you upload data, and if you want to change header or upload parameters.
- **SBE 25plus:** Upload and Header options for the CTD data do not appear in this dialog box.

4. In the Configure menu, select the SBE 55 with the applicable CTD. Click the Upload & Header Options tab. The dialog box looks like this:

Data upload type from **CTD** memory (through ECO) when using Upload on Toolbar or Upload menu:

- All data separated by cast - All data uploaded. Separate file written for each cast, with 3-digit cast ID (001, etc.) appended to user-selected file name.
- Single cast - SeatermAF prompts for cast number, and uploads all data from cast.
- By cast number range - SeatermAF prompts for beginning and ending cast numbers, and uploads data within that range. Separate file written for each cast, with 3-digit cast ID (001, etc.) appended to user-selected file name.
- All data as a single file – All data uploaded into 1 file.
- By scan number range – SeatermAF prompts for beginning and ending scan (sample) numbers, and uploads all data within range into 1 file.

Defines header information included with uploaded data from **CTD** or **ECO** memory, as applicable:

- **Prompt for header information** (default) – Each time data is uploaded, user is prompted to fill out user-defined header form.
- **Include default header form in upload file** – User-defined default header form included in upload file. User is not prompted to add any information when data is uploaded.
- **Do not include default header form in upload file** – Header information not included in upload file.

SeatermAF uploads CTD data in *blocks*, and calculates a checksum at the end of each block. If the block fails the checksum verification, SeatermAF tries to upload the block of data again, cutting the block size in half. For most CTDs, the default block size is 250 scans (samples).

The screenshot shows the 'SBE 55 ECO with SBE 19 Configuration Options' dialog box, specifically the 'Upload & Header Options' tab. The dialog has five tabs: Setup File, Communication Setup, Bottle Closure Logic, Bottle Closure Pressures or Times, and Upload & Header Options. The 'Upload & Header Options' tab is active. It contains several sections:

- Upload options for CTD data upload (.hex) file:**
  - All data separated by cast
  - All data as a single file
  - Single cast
  - By scan number range
- Configure Header Form...:** A button with a callout box pointing to it that says "Click to customize header form; see below."
- Header options for CTD data upload (.hex) file:**
  - Prompt for header information
  - Do not include header information
  - Include default header information
- Header options for SBE 55 data upload (.afm) file:**
  - Prompt for header information
  - Do not include header information
  - Include default header information
- Scans per block for CTD upload:** A text box containing the value '500'.

At the bottom of the dialog are buttons for 'Report', 'Default', 'Help', 'OK', and 'Cancel'.

Click Configure Header Form to customize the header. The dialog box looks like this:

Header information: free form, 0 to 12 lines long. Defines:

- Header **prompts** that appear for user to fill in when uploading data, if *Prompt for header information* was selected on Upload & Header Options tab in Configuration Options dialog box
- Header included with uploaded data, if *Include default header form in upload file* was selected on Upload & Header Options tab in Configuration Options dialog box

Enter the desired header/header prompts. Click OK.

**Note:**

When exiting the program, SeatermAF prompts you to save the instrument settings to the .psa file if they have been modified. Alternatively, to save the settings to the .psa file while still in the Configuration Options dialog box, click on the Setup File tab and click Save or Save As.

Make the selections/enter data on the Upload & Header Options tab. Click OK to temporarily save the settings in the Configuration Options dialog box and to exit the dialog box.

5. Click the Communication Setup tab. The dialog box looks like this:

**Communication between ECO and computer:**

- Computer serial port
- Baud rate, data bits, and parity are fixed (4800, 7, even).

**Communication between CTD and computer** (through ECO and ECO data I/O cable) for **setup**:

- Baud **for setup** must match user-programmable baud set in CTD. See CTD manual for command.
- Data bits and parity must match CTD. See CTD manual.
- **Upload** baud: Baud for uploading data in **CTD** memory to computer (through ECO). **Some** CTDs allow a different baud for upload without the need to manually reset the baud rate in the CTD before starting upload.

**Communication of real-time pressure data from CTD to ECO** (required if closing bottles on upcast, downcast, or when stationary).

- **For most CTDs**, must match user-programmable baud rate set in CTD (and set above in this dialog box). See CTD manual for baud command.

6. Click OK to temporarily save the settings in the Configuration Options dialog box and to exit the dialog box.

**Notes:**

When exiting the program, SeatermAF prompts you to save the instrument settings to the .psa file if they have been modified. Alternatively, to save the settings to the .psa file while still in the Configuration Options dialog box, click on the Setup File tab and click Save or Save As.



## Upload Data from ECO

1. Click Connect ECO on the Toolbar to begin communications with the ECO. The display looks like this:

```
A>
```

This shows that correct communications between the computer and ECO have been established.

If the ECO does not respond as shown above:

- Click Connect ECO again.
  - Verify the correct auto fire instrument was selected in the Configure menu and the communication settings were entered correctly on the Communication Setup tab in the Configuration Options dialog box.
  - Check cabling between the computer and ECO.
  - Check the ECO battery voltage - see *Replacing/Recharging Batteries* in *Section 8: Routine Maintenance*.
2. Disarm the ECO by sending **DA** (the ECO responds with #A> if it is already disarmed).
  3. Display ECO status information by clicking Status on the Toolbar. The display looks like this:

```
SBE 55 V 1.3 15 Dec 2012 16:40:11  
main battery = 11.86 volts  
lithium battery = 2.92 volts  
SBE 55 is NOT ARMED
```

4. Click Upload on the Toolbar to upload data from the ECO. SeatermAF responds as follows:
  - A. SeatermAF sends **DS**, displays the status response, and writes the command and response to the upload file.
  - B. If you selected *Prompt for header information* on the Upload & Header Options tab in the Configuration Options dialog box (Step 4) – a dialog box with the header form appears. Enter the desired header information, and click OK.
  - C. In the Open dialog box, enter the desired upload file name and click OK. SeatermAF automatically adds the .afm file extension.
  - D. SeatermAF sends the data upload command (**DD**), and writes the response to the upload file.

**Note:**

Uploaded data files from the ECO and CTD must have the same name (different extensions) and be in the same directory for processing by SBE Data Processing.

**Note:**

See SBE *25plus* upload procedure after this procedure.

### Upload Data from SBE 19, *19plus*, *19plus V2*, or 25 CTD (not applicable to SBE *25plus*)

1. Click Connect CTD on the Toolbar to begin communications with the CTD. The display looks like this:

```
Connected successfully . . .
S>
```

This shows that correct communications between the computer and CTD has been established.

If the CTD does not respond as shown above:

- Click Connect CTD again.
- Verify the correct CTD was selected in the Configure menu and the CTD communication settings were entered correctly in the Configuration Options dialog box.
- Check cabling between the computer, ECO, and CTD.
- Check the CTD battery voltage.

2. Click Upload on the Toolbar to upload data from the CTD. SeatermAF responds as follows:

- A. SeatermAF sends the status (**DS**) and header (**DH**) commands, displays the responses, and writes the commands and responses to the upload file. These commands provide information regarding the instrument setup, number of samples in memory, cast number, etc.
- B. If you selected *Single cast*, *By cast number range*, or *By scan number range* on the Upload & Header Options tab in the Configuration Options dialog box – a dialog box requests the range/cast number. Enter the desired value(s), and click OK.
- C. **SBE 19plus or 19plus V2:** SeatermAF sends **OutputFormat=0** to the CTD. This sets the CTD format to raw hexadecimal data, which is required for data that will be processed with SBE Data Processing.
- D. If you selected *Prompt for header information* on the Upload & Header Options tab in the Configuration Options dialog box – a dialog box with the header form appears. Enter the desired header information, and click OK.
- E. In the Open dialog box, enter the desired upload file name and click OK. SeatermAF automatically adds the .hex file extension.
- F. SeatermAF sends the data upload command (**DDb,e**) to the CTD through the ECO, and writes the response to the upload file.
- G. **SBE 19plus or 19plus V2:** SeatermAF sends **OutputFormat=4** to the CTD. This sets the CTD format back to pressure in decibars, so it is ready to provide real-time pressure data to the ECO for the next deployment.

**Note:**

Uploaded data files from the ECO and CTD must have the same name (different extensions) and be in the same directory for processing by SBE Data Processing.

### Upload Data from SBE *25plus*

**Note:**

See SBE 19, *19plus*, *19plus V2*, and 25 upload procedure before this procedure.

1. Click Connect CTD on the Toolbar to begin communications with the CTD. The display looks like this:

```
Connected successfully . . .
S>
```

This shows that correct communications between the computer and CTD has been established.

If the CTD does not respond as shown above:

- Click Connect CTD again.
- Verify the correct CTD was selected in the Configure menu and the CTD communication settings were entered correctly on the Communication Setup tab in the Configuration Options dialog box.
- Check cabling between the computer, ECO, and CTD.
- Check the CTD battery voltage.

**Note:**

Uploaded data files from the ECO and CTD must have the same name (different extensions) and be in the same directory for processing by SBE Data Processing.

2. Click Upload on the Toolbar to upload data from the CTD. SeatermAF responds as follows:
  - A. SeatermAF sends **SetOutputExecutedTag=Y**, to put the *25plus* into the configuration required for data upload.
  - B. SeatermAF sends **GetSD** and displays the response. **GetSD** provides information on the instrument status, and number of samples in memory.
  - C. SeatermAF sends **GetFiles** and displays the response. **GetFiles** provides information on all of the files in memory.
  - D. An Upload Data dialog box appears:

Select files to upload. Files are within folders that are organized by date. There are two file types:

- .xml – Data file from CTD, labeled with UTC date and time that cast started, and with *25plus* serial number. Includes serial sensor data if **SetEnableSer1=Y** and/or **SetEnableSer2=Y**, and **SetInlineSer1=Y** and/or **SetInlineSer2=Y**.
- .txt – If your *25plus* is set up with 1 or more serial sensors (**SetEnableSer1=Y** and/or **SetEnableSer2=Y**), and serial sensor data is not stored within CTD data file (**SetInlineSer1=N** and/or **SetInlineSer2=N**), a .txt file is created with serial sensor data for each cast. Beginning of file name is same as .XML file name (UTC date and time that cast started), but then says *serial1* or *serial2* instead of *25plus* serial number.

Click Select Folder to navigate to desired upload file path. Upload files have .xml or .txt extensions. .xml files are compatible with Seasave and SBE Data Processing. You must provide your own software to process .txt files.

**Sub-folder options:**

- Place all files in destination folder – for this example, 3 files selected would be directly placed in Destination folder.
- Place files in sub-folders by cast start date - for this example, there would be 2 sub-folders (2012-03-10, and 2012-03-13), within Destination folder.
- Place files in sub-folders by cast start date and cast start time - for this example, there would be 2 sub-folders (2012-03-10T134108, and 2012-03-13T22726), within Destination folder.

**Name append:** If desired, add an identifying name before extension, to all files to be uploaded. For example, if using a Name Append of HOT, file 2012-03-13T122726 SBE0250003.xml would be uploaded as 2012-03-13T122726 SBE0250003HOT.xml, etc.

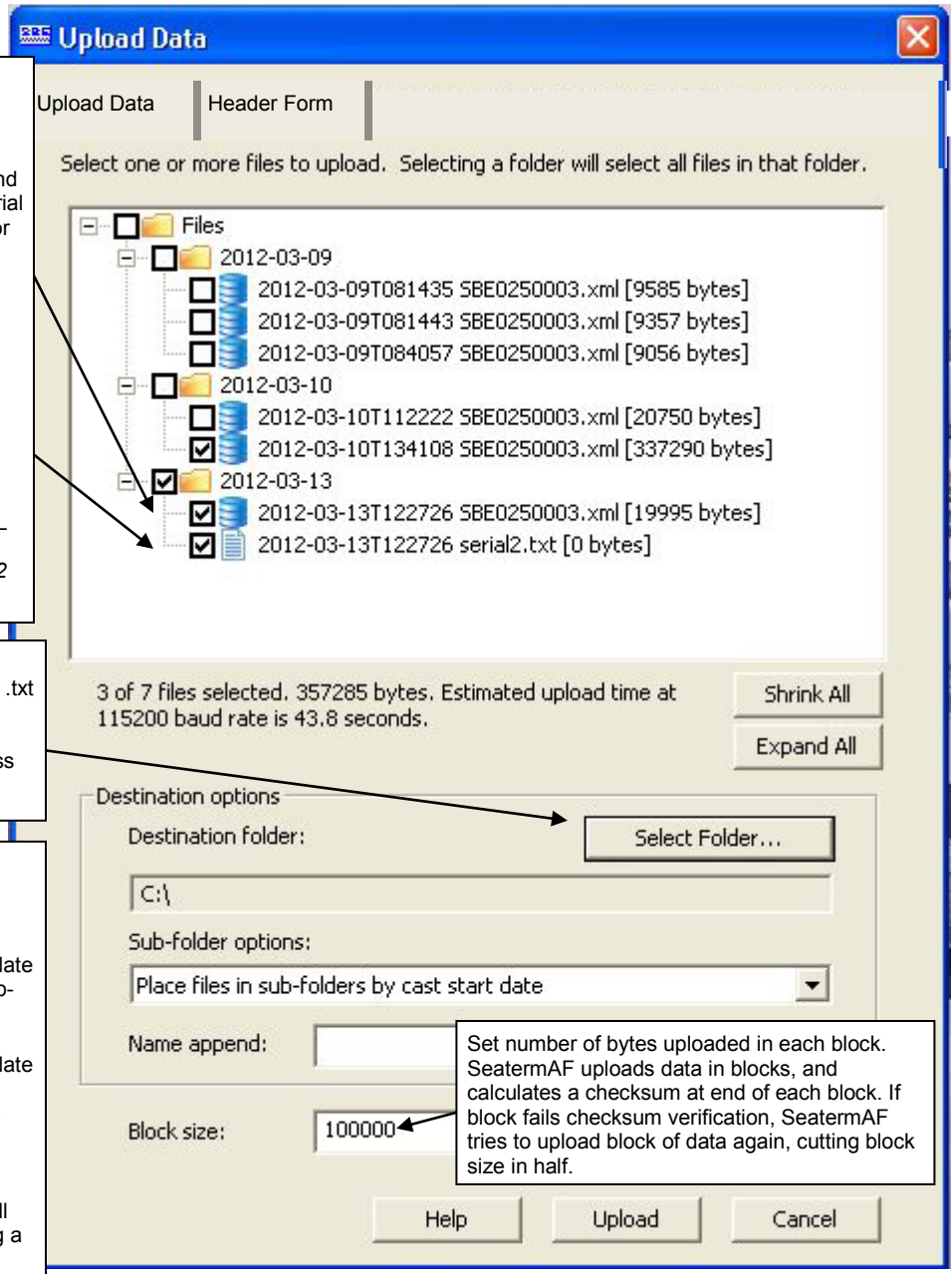

**Note:**

Sea-Bird software (SBE Data Processing and Seasave) cannot process serial sensor data in the uploaded .txt file.

3. Click Upload; the Status bar at the bottom of the window displays the upload progress:
  - A. SeatermAF sends the data upload command, and writes the data to the upload .xml or .txt file, as applicable. The .xml file contains the data in raw hexadecimal, for compatibility with Seasave and SBE Data Processing.
  - B. **If you selected *multiple files*** – SeatermAF repeats Step A for each cast.
  - C. When the data has been uploaded, SeatermAF shows the S> prompt.

**Review Data from ECO and CTD****Note:**

The ECO will enter quiescent (sleep) state after 2 hours without a command have elapsed. Leave the ECO with the batteries in place to retain the date and time. The quiescent current is only 15 microamps, so the batteries can be left in place without significant loss of capacity.

1. Ensure all data has been uploaded from the **ECO** and **CTD** by reviewing the data. Use **SBE Data Processing** to process the files; see *Section 7: Data Processing*.

## ECO Data Formats

When data is uploaded from the ECO using Upload on the Toolbar or the Upload menu, the data is written to a file with a .afm extension. The data consists of:

**Notes:**

- Each line of the ECO header starts with \*.
- See *Section 7: Data Processing* to process the .hex file.

- Header providing the .afm file name, SeatermAF software version, upload time, and ECO status
- For each bottle that was *fired*:
  - bottle closing information, in the following format -  
a b dd mmm yyyy hh:mm:ss.s xxxxxxxx cc.c dd  
*where*

Parameter	Description
a	Bottle sequence
b	Bottle position (first bottle position is '0')
dd mmm yyyy	Date
hh:mm:ss.s	Time
xxxxxxx	Closure confirmation message: <ul style="list-style-type: none"> <li>• confirmed = OK</li> <li>• user cmd = disarm command received</li> <li>• low volt = low battery voltage</li> <li>• no confirm = current through latch magnet insufficient</li> <li>• invalid bn = bottle number received was invalid</li> <li>• no reply = no reply from ECO's latch array</li> </ul>
cc.c	Main battery voltage
dd	Scan number of first of 5 CTD scans recorded with this bottle, <b>counting scans from when ECO was armed</b> . May not correspond to actual scan number in CTD file, where scan number is number of scans since last time memory pointer was reset to beginning of memory. Note: dd is 1 if no CTD was used.

**Note:**

SBE *19plus*, *19plus V2*, *25plus*: The first scan number dd for each bottle may not match the scan number ssssss because of differences in how scans are counted.

- dd is the number of scans counted by the ECO since the ECO was armed.
- ssssss is the number of scans counted by the CTD since the last time **InitLogging** or **SampleNumber=0** was sent to the CTD to reset logging to the beginning of memory.

- (if used with a CTD) 5 scans of CTD data in hex format (see CTD manual for data format details; the parameters included and the order of the parameters varies for each type of CTD).
  - SBE 19 or 25: The ECO records the entire data scan from the CTD, including any auxiliary sensor data.
  - SBE *19plus*, *19plus V2*, or *25plus*: The ECO records only the pressure and scan number, ppppsssss, *where*  
pressure [decibars] = pppp (converted from hex to decimal) – 100;  
ssssss = scan number (converted from hex to decimal).

Shown below is an example .afm file for an ECO used with an SBE 25 CTD; two bottles were closed.

```
* Sea-Bird SBE 25 Data File:
* FileName = C:\Debbie\25test.AFM
* Software Version 1.22
* System UpLoad Time = Feb 20 2007 16:34:06
* ds
* SBE 55 V 1.0 20 Feb 2007 16:40:11
* main battery = 11.86 volts
* lithium battery = 2.92 volts
* SBE 55 is NOT ARMED
* A>

*END*

dd
1 1 20 Feb 2007 16:23:02.7 confirmed 11.9 65
  25F0D40B300B0D991C90B806005E0000000FFF
  25F2A40B30080D971CB0B806105E0000000FFF
  25F49E0B300B0D971CC0B806005E0000000FFF
  25F6540B30130D951CE0B806005E0000000FFF
  25F7A00B30100D951CF0B806005E0000000FFF
2 2 20 Feb 2007 16:23:25.7 confirmed 11.9 88
  2607A80B30130C6D1E80B906005C0000000FFF
  2608410B300E0C561E90B806005C0000000FFF
  2609040B300A0C341EA0B906005C0000000FFF
  2609CA0B300A0C2C1EC0B806005C0000000FFF
  260A930B300B0C2C1ED0B906005C0000000FFF
```

## CTD Data Formats

### Notes:

- Each line of the CTD header starts with \*.
- See *Section 7: Data Processing* to process the .hex file.

When data is uploaded from the CTD (either through the ECO or directly from the CTD) using Upload on the Toolbar or the Upload menu, the data is written to a file with a .hex (SBE 19, *19plus*, *19plus V2*, or 25) or .xml (SBE *25plus*) extension. The data consists of a header and the CTD data. See the CTD manual for details on the CTD data format.

# Section 6: Setting Up, Deploying, and Operating ECO for Real-Time Operation

This section provides a brief review of real-time operation of the ECO with the SBE 33 Deck Unit and SBE 19, *19plus*, *19plus V2*, *25*, *25plus*, or 49 CTD – see the **SBE 33 manual for detailed setup and operation instructions**.

## Wiring System

### Notes:

- The CTD optical isolation feature (SBE 25 - standard; SBE 19 - optional) must be disabled when the CTD is used with the ECO **if providing external power to the CTD**:
  1. Open the CTD main housing.
  2. Solder a jumper wire across the neon bulb on the *above board*.
 See the CTD manual for details on accessing the *above board* and for the board schematic.
 

**This note is not applicable to the SBE 19plus, 19plus V2, 25plus, or 49.**
- See *Dimensions and Connectors and Cables and Wiring* in *Section 2: Description of ECO* for connector pin outs and cable wiring diagrams.

On the ship, cables longer than 3 meters should be installed inside an earthed metal conduit by a qualified electrician. This minimizes the potential for external signals to disrupt communication and ensures that high voltage lines (such as the sea cable) are sufficiently protected. Cables shorter than 3 meters can be used without shielding when installing or bench testing the instrument.

Wire the system:

- Connect the ECO's 6-pin *Instrument* connector (**counter-clockwise** from 2-pin *Sea Cable* connector on the Electronics Control Module) to the CTD, using the 6-pin to 4-pin CTD cable supplied with the system.
 

**Note:** SBE 19 and 25 CTDs configured with a pump, and all SBE *19plus V2* and *25plus* CTDs, have a 6-pin data I/O – pump connector. These CTDs are supplied with a Y-cable (6-pin to CTD, 4-pin data I/O, 2-pin pump); connect the ECO to the 4-pin data I/O connector on the Y-cable.
- Connect the ECO's 2-pin *Sea Cable* connector on the Electronics Control Module to the *Sea Cable* connector on the SBE 33 Deck Unit.
- The ECO's Electronics Control Module has two 4-pin *Latch Array* connectors, each controlling one latch assembly (3 bottles per latch assembly). Connect each of the 4-pin *Latch Array* connectors to the connector on a latch assembly.

See the CTD manual for connections to auxiliary sensors, and see the SBE 33 manual for connections to computer and auxiliary equipment

## Setup and Deploying System

### Note:

When using the **SBE 49 FastCAT** with the SBE 33:

- Seasave does not support acquisition of Surface PAR data.
- If the SBE 49 is not set to **AutoRun=Y** (start sampling automatically when power is applied), start sampling by sending the SBE 49 the **Start** command in Seaterm before you run Seasave.

### Note:

The configuration (.xmlcon or .con) file defines the CTD - auxiliary sensors integrated with the instrument, and channels, serial numbers, and calibration dates and coefficients for all integrated sensors (conductivity, temperature, pressure, and auxiliary sensors). Additionally, the configuration file defines if NMEA and/or Surface PAR data is to be appended to the CTD data. Seasave (and our data processing software) uses the information in the file to interpret and process the raw data. **If the configuration file does not match the actual instrument configuration, the software will not be able to interpret and process data correctly.**

### In Seaterm:

1. Set up the SBE 33 and CTD.

Note: If using the SBE 19*plus* V2 CTD, you can connect the CTD directly to the computer (instead of to the ECO) and use SeatermV2 instead of Seaterm to more easily set up the CTD.

### In Seasave:

2. Click Configure Inputs.
  - A. Click the Instrument Configuration tab. Select the CTD configuration (.xmlcon or .con) file.
  - B. Click the Serial Ports tab and set up CTD and water sampler communication parameters.
    - CTD communications - select the serial port connected to the SBE 33 *Serial Data* connector and the baud rate between the SBE 33 and the computer; the baud rate must agree with the SBE 33 dip switch setting. Set the data bits to 7 and parity to even.
    - Water sampler communications - select the serial port connected to the SBE 33 *Carousel Data* connector.
  - C. Click the Water Sampler tab. Select the water sampler type (**SBE ECO**), total number of bottles to be closed, and firing sequence. If applicable, enter bottle positions for table driven firing or auto fire pressure and positions.
  - D. Perform any other desired setup in the Configure Inputs dialog box, and click OK.
3. Perform any other desired setup in Configure Outputs and Display.

### CAUTION:

**Do not use WD-40** or other petroleum-based lubricants, as they will damage the connectors.

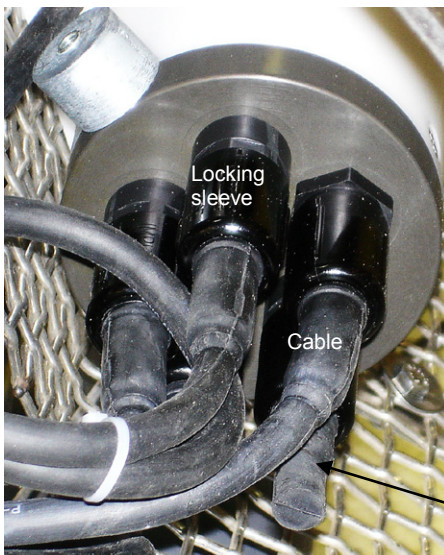

Dummy plug

Electronics Control Module shown; verify dummy plug or cable installed for every connector on ECO and CTD

4. Verify that a cable connector or dummy plug is installed for every connector on the ECO and CTD:
  - A. Lightly lubricate the inside of the cable connector or dummy plug with silicone grease (DC-4 or equivalent).
  - B. **Standard Connector** - Install the cable connector/plug, aligning the raised bump on the side of the connector/plug with the large pin (pin 1 - ground) on the instrument. Remove any trapped air by burping or gently squeezing the connector/plug near the top and moving your fingers toward the end cap. **OR**  
**MCBH Connector** - Install the cable connector/plug, aligning the pins.
  - C. Place the locking sleeve over the connector/plug. Tighten the locking sleeve finger tight only. Do not overtighten the locking sleeve and do not use a wrench or pliers.



5. In Seasave's Real Time Data menu, select *Start*.
  - A. Enter the desired name and location for the output data file.
  - B. Make any other desired selections.
  - C. Click *Start*. If the CTD is not already on, Seasave prompts you to turn on the CTD's switch.
6. To fire a bottle from Seasave:
  - Press Ctrl F3, **or**
  - In the Real-Time Control menu, select *Fire Bottle Control*. The *Bottle Fire* dialog box appears (you can leave this open throughout the cast). Click *Fire Bottle*.
7. To fire a bottle from the SBE 33 front panel:
  - A. Set the *Bottle to Fire* switch to 00 and then press *Reset*.
  - B. To fire in random order, set the *Bottle to Fire* switch to the desired bottle and press *Fire*.
  - C. To fire in sequential order, set the *Bottle to Fire* switch to 99 before firing the first bottle. Press *Fire*. ECO fires bottle 1, and then fires in sequential order each time that *Fire* is pressed.
8. To stop real-time data acquisition: In the Real-Time Data menu, select *Stop*.
9. Stop the CTD logging, using the method applicable to your CTD.
10. If desired, upload the data in the CTD memory for comparison with the real-time data saved by **Seasave**.
  - Connect the ECO directly to the computer and use SeatermAF to upload the CTD data from memory (through the ECO).
  - Alternatively, connect the CTD directly to the computer and use Seaterm (for SBE 19, 19*plus*, or 25) or SeatermV2 (SBE 19*plus* V2 or 25*plus*) to upload the CTD data from memory.
11. Use **SBE Data Processing** to process the data; see *Section 7: Data Processing*.

**Note:**

The ECO will enter quiescent (sleep) state after 2 hours without a command have elapsed. Leave the ECO with the batteries in place to retain the date and time. The quiescent current is only 15 microamps, so the batteries can be left in place without significant loss of capacity.

## Recovery

**WARNING!**

**If the ECO, CTD, or auxiliary equipment/sensors stop working while underwater, are unresponsive to commands, or show other signs of flooding or damage, carefully secure the instrument away from people until you have determined that abnormal internal pressure does not exist or has been relieved.**

Pressure housings may flood under pressure due to dirty or damaged o-rings, or other failed seals. When a sealed pressure housing floods at great depths and is subsequently raised to the surface, water may be trapped at the pressure at which it entered the housing, presenting a danger if the housing is opened before relieving the internal pressure.

Instances of such flooding are rare. However, a housing that floods at 600 meters depth holds an internal pressure of more than 800 psia, and has the potential to eject the end cap with lethal force. A housing that floods at 50 meters holds an internal pressure of more than 85 psia; this force could still cause injury.

If you suspect the ECO's Electronics Control Module is flooded, point the Electronics Control Module in a safe direction away from people, and loosen 1 end cap bulkhead connector very slowly, at least 1 turn. This opens an o-ring seal under the connector. Look for signs of internal pressure (hissing or water leak). If internal pressure is detected, let it bleed off slowly past the connector o-ring. Then, you can safely remove the end cap.

Rinse the ECO, CTD, and auxiliary equipment and sensors with fresh water, and dry thoroughly.

## Bottle Log (.bl) Data Output Formats

**Note:**

See *Section 7: Data Processing* to process the .bl file.

Scan range data for creation of the water bottle file typically comes from the bottle log (.bl) file, if you used Seasave to acquire real-time data. Seasave creates the .bl file - each time a bottle fire confirmation is received, the bottle sequence number, position, date, time, and beginning and ending scan numbers (1.5-sec duration for each bottle) are written to the .bl file.

The .bl file consists of:

- Header providing the .bl file name and the time the *Reset* command was sent to the ECO.
- For each bottle that was *fired*, bottle closing information, in the following format - a, b, mmm dd yyyy hh:mm:ss.s, bb, ee

where

Parameter	Description
a	Bottle sequence
b	Bottle position (first bottle position is '0')
mmm dd yyyy	Date
hh:mm:ss.s	Time
bb	Beginning CTD scan number associated with this bottle
ee	Ending CTD scan number associated with this bottle (providing a 1.5 sec duration; number of scans varies, depending on CTD sampling rate)

---

## CTD Data Formats

**Notes:**

- Each line of the CTD header starts with \*.
- See *Section 7: Data Processing* to process the data.
- See *Uploading Data* in *Section 5: Setting Up, Deploying, and Operating ECO for Autonomous Operation* to upload the CTD data from its memory, if desired. Data uploaded from memory provides a back-up to the real-time data, if there were telemetry problems during real-time data acquisition.

**When data is saved to a file by Seasave**, the data is written in hex format to a file with a .hex extension. The data consists of a header and the CTD data. See the CTD (SBE 19, 19*plus*, 19*plus* V2, 25, or 25*plus*) manual for details on the CTD data format.

**When data is uploaded from the CTD**, the data is written to a file with a .hex (SBE 19, 19*plus*, 19*plus* V2, or 25) or .xml (SBE 25*plus*) extension. The data consists of a header and the CTD data. See the CTD manual for details on the CTD data format.

# Section 7: Data Processing

**Note:**

Basic instructions are provided for processing the data using SBE Data Processing. See the SBE Data Processing manual / Help files.

This section provides basic instructions for processing .afm files from the ECO and data files from the SBE 19, 19*plus* V2, 25, or 25*plus*.

The data files are processed in SBE Data Processing in two steps:

1. **Data Conversion** module - Data Conversion creates:
  - .cnv file (from CTD data file) - CTD data converted to engineering units.
  - .ros water bottle file (from CTD data and .afm files from autonomous operation, or from CTD data and .bl files from real-time operation) - data converted from raw to engineering units. The .ros file contains the CTD data for the scans associated with each bottle firing as well as a user-selected range of scans before and after each bottle firing.
2. **Bottle Summary** module - The .ros file created by Data Conversion is processed by Bottle Summary, which creates a bottle data summary .btl file. The .btl file includes:
  - Bottle position, optional bottle serial number, and date and time.
  - User-selected derived variables, computed for each bottle from mean values of input variables (temperature, pressure, conductivity, etc.).
  - User-selected averaged variables, computed for each bottle from input variables.

The use of Data Conversion and Bottle Summary is described below (see the SBE Data Processing manual/Help files for details).

## Data Conversion

**Note:**

The .afm or .bl file with bottle file information are not selected on the File Setup tab. SBE Data Processing looks for these files in the same directory as the CTD data (.hex or .xml) file, with the same name as the data file but different extension.

In SBE Data Processing’s Run menu, select Data Conversion. The input files for Data Conversion are the .hex file from the CTD and the CTD configuration (.xmlcon or .con) file, and the file with the bottle fire information (.afm file for autonomous operation, .bl file for real-time operation). The File Setup tab in the dialog box looks like this:

Location to store all information input in File Setup and Data Setup tabs. **Open** to select a different .psu file, **Save** or **Save As** to save current settings, or **Restore** to reset all settings to match last saved version.

Instrument configuration (.xmlcon or .con) file location. **Select** to pick a different file, or **Modify** to view and/or modify configuration.

Directory and file names for raw data (.hex or .xml) from **CTD**. **Select** to pick a different file. To process multiple raw data files from same directory:  
 1. Click **Select**.  
 2. In Select dialog box, hold down Ctrl key while clicking on each desired file.

- Select to have program find configuration file with same name and in same directory as data file. For example, if processing test.hex and this option is selected, program searches for test.xmlcon (same directory as test.hex); if it does not find test.xmlcon, it searches for test.con.
- Also select if more than 1 data file is to be processed, **and** data files have different configuration files. For example, if processing test.hex and test1.hex, and this option is selected, program searches for test.xmlcon and test1.xmlcon (same directory as test.hex and test1.hex); if it does not find .xmlcon files, it searches for .con files.

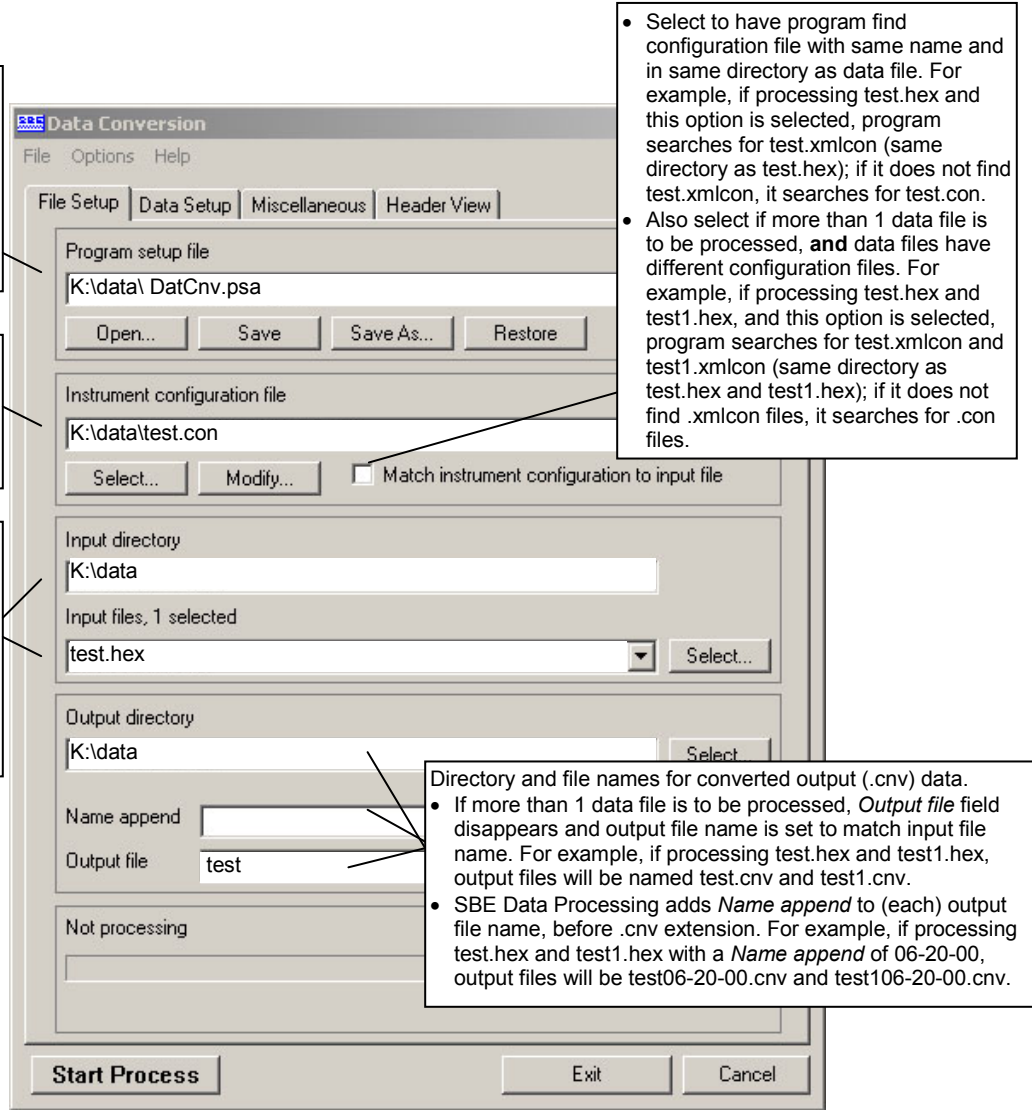

- Directory and file names for converted output (.cnv) data.
- If more than 1 data file is to be processed, *Output file* field disappears and output file name is set to match input file name. For example, if processing test.hex and test1.hex, output files will be named test.cnv and test1.cnv.
  - SBE Data Processing adds *Name append* to (each) output file name, before .cnv extension. For example, if processing test.hex and test1.hex with a *Name append* of 06-20-00, output files will be test06-20-00.cnv and test106-20-00.cnv.

The Data Setup tab in the dialog box looks like this:

**Data Conversion**

File Options Help

File Setup Data Setup Miscellaneous Header View

Process scans to end of file

Scans to skip over: 0

Scans to process: 1

Output format: ASCII output

Convert data from: Upcast and downcast

Create file types: Create both data and bottle file

Source of scan range data: Auto-Fire module or ECO (.AFM) file

Scan range offset [s]: 0

Scan range duration [s]: 2

Merge separate header file

Select Output Variables...

Source for start time in output .cnv header

Instrument's time stamp  System UTC

NMEA time  Upload time

Prompt for start time and/or note

Start Process Exit Cancel

**Callout 1 (top left):** Program skips first scans to skip over scans.  
 • If *Process scans to end of file* selected: process all remaining scans (upcast and downcast scans if *Upcast and downcast* selected; downcast scans only if *downcast* selected).  
 • If *Process scans to end of file* not selected: process next scans to process.

**Callout 2 (top right):**  
 • Binary - smaller file, processed faster than ASCII file by other SBE Data Processing modules.  
 • ASCII - larger file, can be viewed with a text editor. SBE Data Processing's Translate module can translate converted data file from binary to ASCII or vice versa.

**Callout 3 (middle right):** Create converted data .cnv file only, bottle .ros file only (for subsequent processing by Bottle Summary), or both.

**Callout 4 (right):** **Source of data for .ros bottle file:** file in same directory as CTD data (.hex) file, with same file name but with .afm extension (if used autonomous operation), or .bl extension (if used real-time operation).

**Callout 5 (middle right):** **Define scans from CTD data file to be included in .ros bottle file for each bottle.** Amount of data written to .ros file is based on:  
 • *Offset* defines first scan output to .ros file for each bottle, relative to first scan written to .afm or .bl file.  
 • *Duration* defines number of scans output to .ros file for each bottle. See example below.

**Callout 6 (left):** Select to replace existing header in input .hex file with header in .hdr file. Program looks for a file with a matching name (but .hdr extension) in same directory as input file.

**Callout 7 (left):** Select which variables to convert and output (see dialog box below).

**Callout 8 (bottom right):** **Select start time source for header:**  
 • Instrument's time stamp – instrument's time stamp in first data scan (if available) or in header of input raw data file.  
 • NMEA time – NMEA time (real-time use only).  
 • System UTC – computer time in first data scan (if available) or in header of input raw data file.  
 • Upload time – time that data was uploaded from instrument's memory.

**Example:** Scan range offset = -2 sec, Scan range duration = 5 sec.

**Example 1:** Scans 1,000 - 1,004 written to .afm for first bottle on ECO with 19plus (4 Hz sampling = 4 scans/sec).  
 $1,000 - (2 \text{ sec offset} \times 4 \text{ scans/sec}) = 992$   
 $992 + (5 \text{ sec duration} \times 4 \text{ scans/sec}) = 1,012$   
 Scans 992 - 1,012 will be written to .ros file for first bottle.

**Example 2:** Scans 1,000 - 1,005 written to .bl for first bottle on ECO with 19plus (4 Hz sampling = 4 scans/sec; 1.5 sec of data in .bl is 6 scans).  
 $1,000 - (2 \text{ sec offset} \times 4 \text{ scans/sec}) = 992$   
 $992 + (5 \text{ sec duration} \times 4 \text{ scans/sec}) = 1,012$   
 Scans 992 - 1,012 will be written to .ros file for first bottle.

The Select Output Variables dialog box (which appears when you click **Select Output Variables** on the Data Setup tab) looks like this:

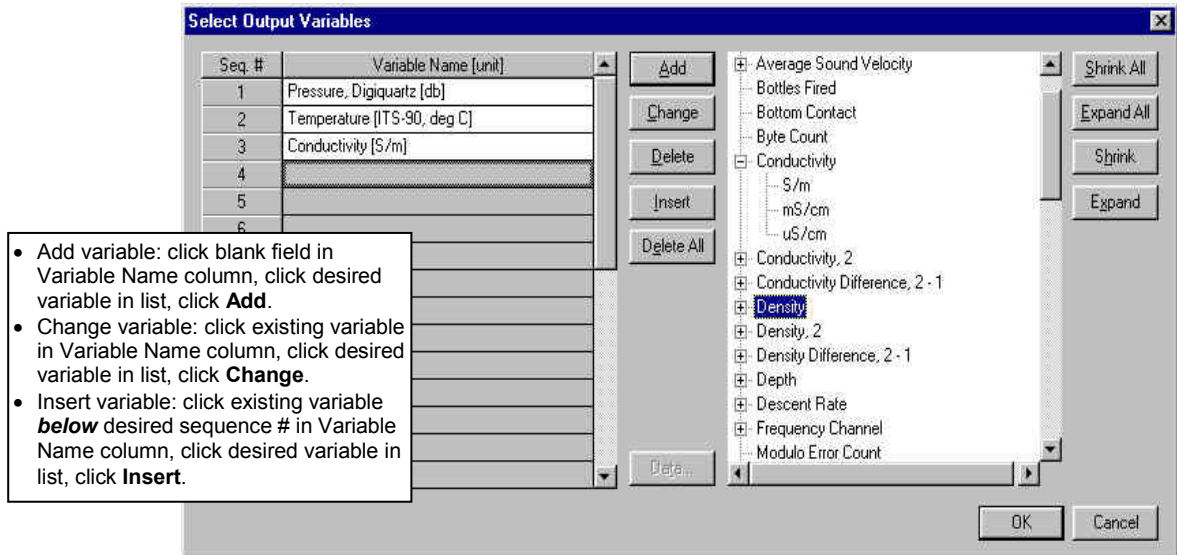

**Output variables selected here will be put in both the .cnv and .ros files.**

## Bottle Summary

In SBE Data Processing's Run menu, select Bottle Summary. The File Setup tab in the dialog box is similar to the one shown and described for Data Conversion above. The input files for Bottle Summary are the .ros file (created in Data Conversion) and the CTD configuration (.xmlcon or .con) file.

**Note:**

You can create a .sn file in a text editor.

- Additionally, if a .sn file (same name as input .ros file, with .sn extension) is found in the input file directory, bottle serial numbers are inserted between the bottle position and date/time columns in the .bt1 file output. The format for the .sn file is:  
Bottle position, serial number (with a comma separating the two fields)

The Data Setup tab in the dialog box looks like this:

**Oxygen selections apply to SBE 43 and Beckman/YSI sensors (they do not apply to SBE 63 or Aanderaa Oxygen Optode):**  
Tau correction ( $[\tau(T,P) * \delta V / \delta t]$  in SBE 43 or  $[\tau * \text{doc}/dt]$  in SBE 13 or 23) improves response of measured signal in regions of large oxygen gradients. However, this term also amplifies residual noise in signal (especially in deep water), and in some situations this negative consequence overshadows gains in signal responsiveness.

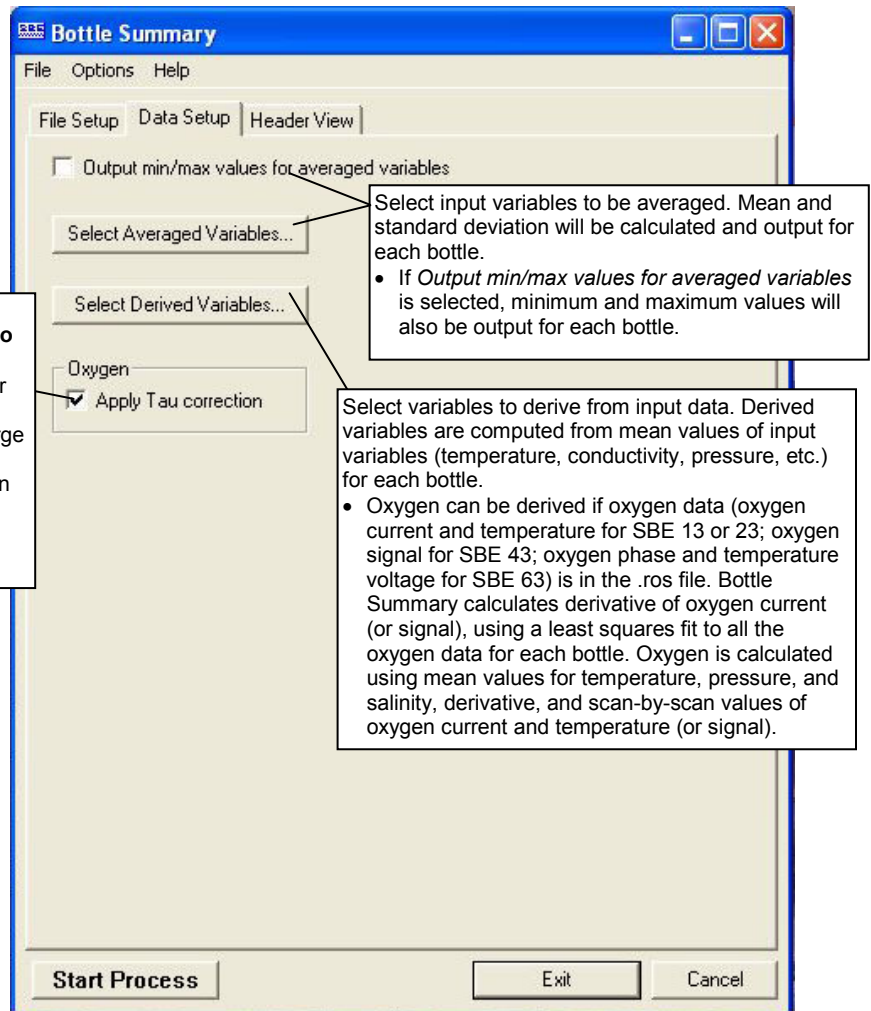

## Other Processing Modules

See the SBE Data Processing manual/Help files for information on additional processing that can be performed on the converted CTD data (.cnv) file.



# Section 8: Routine Maintenance

This section reviews:

- Corrosion precautions / cleaning
- Connector mating and maintenance
- Bottle maintenance
- Storage
- Replacing / recharging batteries
- Removal of latch assembly and center pylon

---

## Corrosion Precautions / Cleaning

### CAUTION:

Do not use WD-40 or other petroleum-based lubricants, as they will damage the trigger mechanism.

Rinse the **entire** ECO with **fresh** water after each cast.

- The trigger mechanism is titanium. The titanium is coated with Tiodizing; this product is similar to anodizing aluminum. **The Tiodized surface is water lubricating and should never be oiled with petroleum or silicon-based products.** Rinse the trigger mechanism with **fresh** water after each cast and clean it periodically with warm, soapy water. If the mechanism sticks after cleaning, remove the latch assembly and immerse it in warm, soapy water. See *Removing / Replacing Latch Assembly*.
- Rinse the inside and outside of all the **bottles** with **fresh** water, to prevent salt deposits on the tubing that close the bottles.
- Some ECOs were sold with an aluminum connector end cap on the Electronics Control Module. A large zinc anode is screwed to the end cap, to provide corrosion protection. Check the anode periodically to verify that it is securely fastened and has not been eaten away.

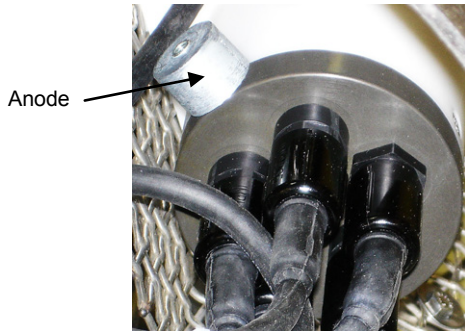

## Connector Mating and Maintenance

### Note:

See *Application Note 57: Connector Care and Cable Installation*.

### CAUTION:

**Do not use WD-40** or other petroleum-based lubricants, as they will damage the connectors.

Clean and inspect connectors, cables, and dummy plugs before every deployment and as part of your yearly equipment maintenance. Inspect connectors that are unmated for signs of corrosion product around the pins, and for cuts, nicks or other flaws that may compromise the seal.

When remating:

1. Lightly lubricate the inside of the dummy plug/cable connector with silicone grease (DC-4 or equivalent).
2. **Standard Connector** - Install the plug/cable connector, aligning the raised bump on the side of the plug/cable connector with the large pin (pin 1 - ground) on the ECO. Remove any trapped air by *burping* or gently squeezing the plug/connector near the top and moving your fingers toward the end cap. **OR**  
**MCBH Connector** – Install the plug/cable connector, aligning the pins.
3. Place the locking sleeve over the plug/cable connector. Tighten the locking sleeve finger tight only. **Do not overtighten the locking sleeve and do not use a wrench or pliers.**

Verify that a cable or dummy plug is installed for each connector on the system before deployment.

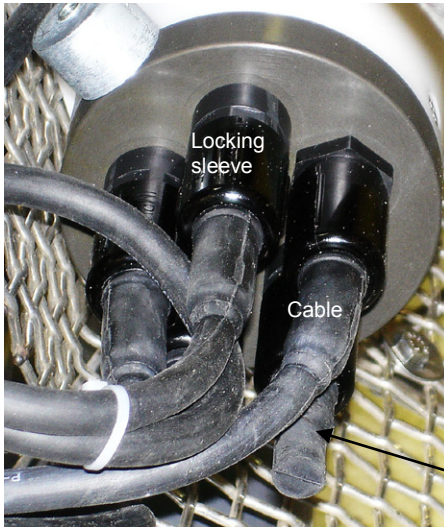

Electronics Control Module shown; verify dummy plug or cable installed for every connector on ECO and CTD

## Bottle Maintenance

As described above in *Corrosion Precautions / Cleaning*, rinse the inside and outside of each bottle with fresh water after every cast to prevent salt deposits on the tubing that closes each bottle.

- Periodically inspect the tubing for tears and to ensure the proper amount of tension. Replace the tubing if it becomes torn or damaged from salt deposits, or is overstretched.
- Periodically inspect the bottle O-rings (end caps, air bleed valve, and drain) for tears and cracks. We recommend replacement of the O-rings every 3 to 4 years, regardless of condition.

## Storage

Store the ECO with the bottles closed to preserve the tension of the tubing that closes the bottles.

If the ECO is stored on deck, we recommend covering it to keep off salt spray and protect the plastic parts from UV rays. At a minimum, a cover for the latch assembly is a good investment.

## Replacing / Recharging Batteries

Leave the batteries in place in the Electronics Control Module when storing the ECO to prevent depletion of the back-up lithium batteries by the real-time clock. Even *exhausted* main batteries will power the clock (15 microamps) almost indefinitely. If the ECO is to be stored for long periods, leave the batteries in place and replace them yearly.



Alkaline D-cell  
(MN1300, LR20)

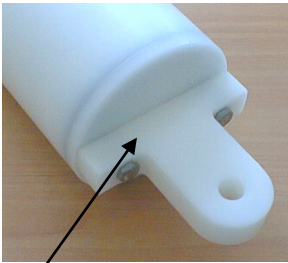

Unthread cap by rotating counter-clockwise

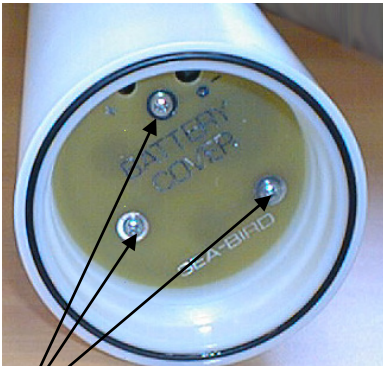

Remove Phillips-head screws and washers

### Replacing Alkaline Batteries

The Electronics Control Module uses alkaline D-cells (Duracell MN1300, LR20), dropped into the battery compartment.

1. Remove the battery end cap (end cap without connectors):
  - A. Wipe the outside of the end cap and housing dry, being careful to remove any water at the seam between them.
  - B. Unthread the end cap by rotating counter-clockwise (use a wrench on the white plastic bar if necessary).
  - C. Remove any water from the O-ring mating surfaces inside the housing with a lint-free cloth or tissue.
  - D. Put the end cap aside, being careful to protect the O-ring from damage or contamination.
2. Remove the battery cover plate from the housing:
  - A. Remove the three Phillips-head screws and washers from the battery cover plate inside the housing.
  - B. The battery cover plate will pop out. Put it aside.
3. Turn the Electronics Control Module over and remove the batteries.
4. Install the new batteries, with the + terminals against the flat battery contacts and the - terminals against the spring contacts.
5. Reinstall the battery cover plate in the housing:
  - A. Align the battery cover plate with the housing. The posts inside the housing are not placed symmetrically, so the cover plate fits into the housing only one way. Looking at the cover plate, note that one screw hole is closer to the edge than the others, corresponding to the post that is closest to the housing.
  - B. Reinstall the three Phillips-head screws and washers, while pushing hard on the battery cover plate to depress the spring contacts at the bottom of the battery compartment. **The screws must be fully tightened, or battery power to the circuitry will be intermittent.**
6. Check the battery voltage at BAT + and BAT - on the battery cover plate. It should be approximately 13.5 volts.
7. Reinstall the battery end cap:
  - A. Remove any water from the O-rings and mating surfaces with a lint-free cloth or tissue. Inspect the O-rings and mating surfaces for dirt, nicks, and cuts. Clean or replace as necessary. Apply a light coat of o-ring lubricant (Parker Super O Lube) to O-rings and mating surfaces.
  - B. Carefully fit the end cap into the housing and rethread the end cap into place. Use a wrench on the white plastic bar to ensure the end cap is tightly secured.

## Recharging Optional Nickel Metal Hydride Batteries

See the *NiMH Battery Charger and Battery Pack* manual for complete details on charging, error messages, battery specifications, etc.

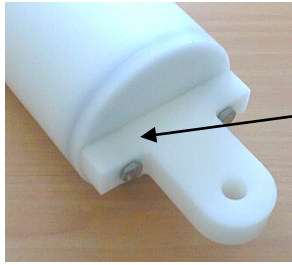

Unthread cap by rotating counter-clockwise

1. Remove the battery end cap (end cap without connectors):
  - A. Wipe the outside of the end cap and housing dry, being careful to remove any water at the seam between them.
  - B. Unthread the end cap by rotating counter-clockwise (use a wrench on the white plastic bar if necessary).
  - C. Remove any water from the O-ring mating surfaces inside the housing with a lint-free cloth or tissue.
  - D. Put the end cap aside, being careful to protect the O-ring from damage or contamination.

**Note:**

**If desired, you can recharge the NiMH battery pack while it is in the housing.** Skip Steps 2 and 4 if recharging in the housing.

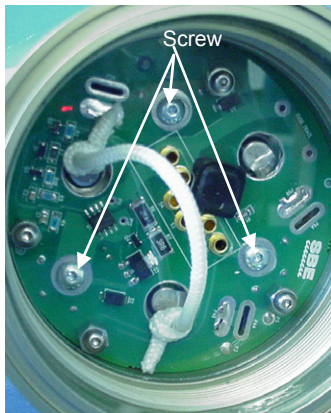

Screw

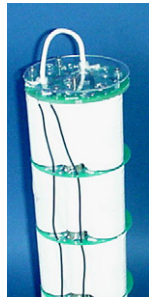

9-cell Battery pack

2. Remove the battery pack from the housing:
  - A. The protective plastic plate over the battery cover plate prevents you from completely removing the cap screws that connect the battery pack to the Electronics Control Module's battery posts in one step. Each of the screws is 12 mm (1/2 inch) long, but the clearance between the cover plate and plastic plate is only 6 mm (1/4 inch). Unscrew each of the three cap screws **just until they hit the bottom of the protective plastic plate**. The battery pack will *walk* out of the housing approximately 6 mm (1/4 inch) because of the spring contacts at the bottom of the battery compartment. Unscrew the cap screws again. The battery pack will *walk* out of the housing again, and should now be disconnected from the battery posts.
  - B. Pull on the cord to remove the battery pack from the housing.

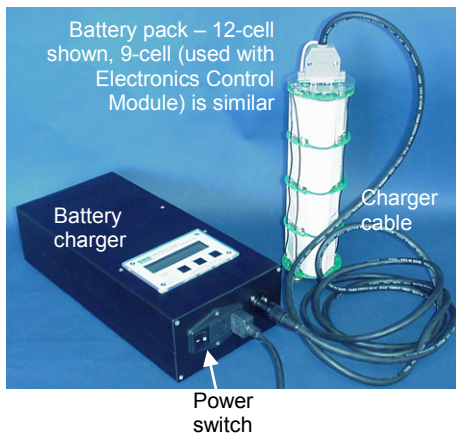

Battery pack – 12-cell shown, 9-cell (used with Electronics Control Module) is similar

Battery charger

Charger cable

Power switch

3. Recharge the batteries:
  - A. Plug the battery charger into a suitable power source and turn on power to the charger.
  - B. Connect the charger cable to the battery pack and charger. The LED should show **READY**, and display the battery type and measured voltage.
  - C. Press the **Discharge** button. The LED should show **DISCHARGE**. This starts the discharge cycle, which discharges any remaining battery capacity. Repeatedly charging without discharging may damage the battery pack. The Discharge cycle takes approximately 110 minutes. When discharging is complete, the LED should show **EMPTY**.
  - D. Press the **Charge** button. The LED should show **Fast Charge** (it may also show **WARM-UP CHARGE**, **REFILL CHARGE**, and/or **TOP OFF** during the charge cycle). The Charge cycle takes approximately 2 hours. When charging is complete, the LED should show **BATTERY FULL**.
  - E. Turn off power to the charger.
  - F. Disconnect the battery pack from the charger and the charger from the power source.

**WARNING!**

**Do not disconnect the battery while the Charger Active lamp is on. Doing so may cause a small spark.**

**Note:**

The NiMH battery pack fits tightly in the housing. When placing a battery pack in the housing, align it carefully and slowly insert it straight into the housing. If not careful, the battery pack shrink wrap can be torn.

4. Reinstall the battery pack in the housing:
  - A. Align the battery pack with the housing. The posts inside the housing are not placed symmetrically, so the battery pack fits into the housing only one way. Looking at the bottom of the battery pack, note that one tube is closer to the edge than the others, corresponding to the post that is closest to the housing.
  - B. Reinstall the three cap screws until they are snug against the top plate. While pushing hard on the protective plastic plate to depress the spring contacts at the bottom of the compartment, continue to tighten the cap screws. Repeat until all three cap screws are tightened and the battery pack cannot be pushed further into the housing. **The screws must be fully tightened, or battery power to the circuitry will be intermittent.**
  
5. Reinstall the battery end cap:
  - A. Remove any water from the O-rings and mating surfaces with a lint-free cloth or tissue. Inspect the O-rings and mating surfaces for dirt, nicks, and cuts. Clean or replace as necessary. Apply a light coat of O-ring lubricant (Parker Super O Lube) to O-rings and mating surfaces.
  - B. Carefully fit the end cap into the housing and rethread the end cap into place. Use a wrench on the white plastic bar to ensure the end cap is tightly secured.



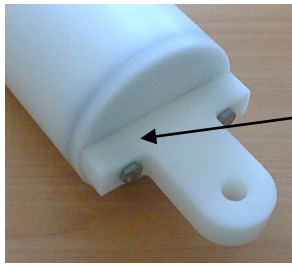

Unthread cap by rotating counter-clockwise

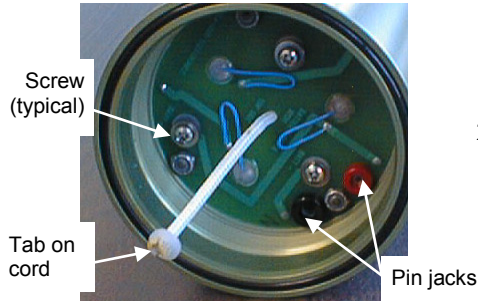

**CAUTION:**

**Do not recharge the Ni-Cad battery pack while it is in the housing.** If you do so, you may damage the Electronics Control Module's electronics.

## Recharging Optional Nickel-Cadmium Batteries

Note: Ni-Cad battery pack and charger are no longer available.

1. Remove the battery end cap (end cap without connectors):
  - A. Wipe the outside of the end cap and housing dry, being careful to remove any water at the seam between them.
  - B. Unthread the end cap by rotating counter-clockwise (use a wrench on the white plastic bar if necessary).
  - C. Remove any water from the O-ring mating surfaces inside the housing with a lint-free cloth or tissue.
  - D. Put the end cap aside, being careful to protect the O-ring from damage or contamination.
  
2. Remove the battery pack from the housing:
  - A. Remove the three Phillips-head machine screws and washers from the battery cover plate inside the housing.
  - B. Pull on the plastic tab on the center cord to remove the battery pack from the housing.
  
3. Recharge the batteries:
  - A. Connect the battery charger leads to the battery cover pin jacks, matching black-to-black and red-to-red (the pin jacks are different sizes to prevent cross-wiring).
  - B. Plug the battery charger into a suitable AC mains power source.
  - C. The red **Charge** LED on the charger comes on. Recharging takes approximately 15 hours. When recharging is complete, the yellow **Trickle** LED comes on, indicating the charger is providing a maintenance level charge.
  - D. Disconnect the battery pack from the charger and the charger from the power source.
  - E. Check the voltage at BAT + and BAT – on the battery cover. It should be approximately 10.8 volts.
  
4. Reinstall the battery pack in the housing:
  - A. Align the battery pack with the housing. The posts inside the housing are not placed symmetrically, so the battery pack fits into the housing only one way. Looking at the battery bottom cover, note that one circular cutout is closer to the edge than the others, corresponding to the post that is closest to the housing.
  - B. Reinstall the three Phillips-head screws and washers, while pushing hard on the top of the battery pack to depress the spring contacts at the bottom of the compartment. **The screws must be fully tightened, or the battery power to the circuitry will be intermittent.**
  
5. Reinstall the battery end cap:
  - A. Remove any water from the O-rings and mating surfaces with a lint-free cloth or tissue. Inspect the O-rings and mating surfaces for dirt, nicks, and cuts. Clean or replace as necessary. Apply a light coat of O-ring lubricant (Parker Super O Lube) to O-rings and mating surfaces.
  - B. Carefully fit the end cap into the housing and rethread the end cap into place. Use a wrench on the white plastic bar to ensure the end cap is tightly secured.

## Removing / Replacing Latches

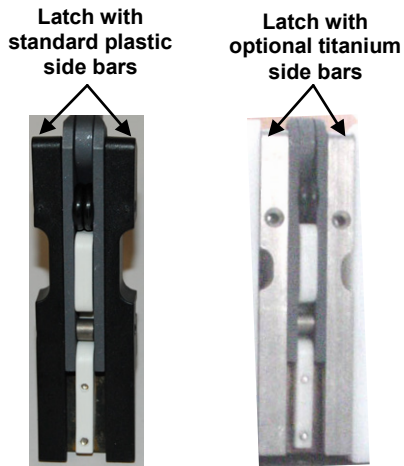

Latches are available with standard plastic side bars, or optional titanium side bars for more demanding applications.

### Removing Latches

1. Remove the latch assembly from the frame:
  - A. Remove the screws and washers from the side of the latch assembly.
  - B. Remove the *football*-shaped frame, pulling it straight up.
  - C. Lift the latch assembly(s) off the frame.
2. Remove individual triggers if desired:
  - A. Remove the two socket-head screws from the trigger.
  - B. Pull the trigger horizontally from the latch assembly. Mark the trigger to aid in reassembly.

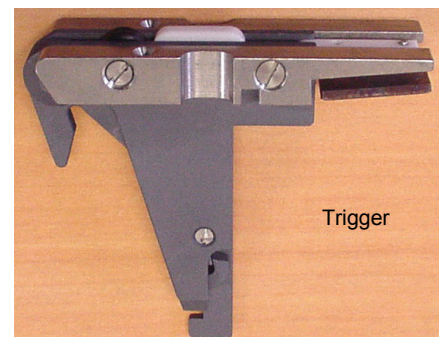
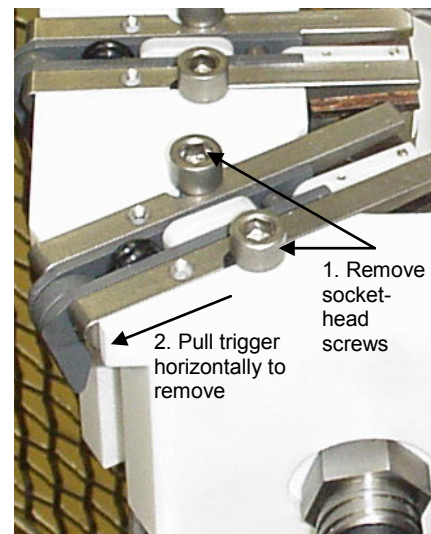

### Replacing Latches

1. Replace the trigger(s) on the latch assembly. Reinstall the two socket-head screws to secure each trigger to the latch assembly.
2. Place the latch assembly(s) on the frame. Reinstall the *football*-shaped frame, and secure it with screws and washers.

# Glossary

**Battery** – nine alkaline D-cells standard; optional NiMH or Ni-Cad battery pack can be substituted.

Note: Ni-Cad battery pack and charger are no longer available.

**CTD** – profiling instrument for measuring Conductivity, Temperature, and Depth (pressure); some CTDs can be integrated with auxiliary sensors to measure oxygen, pH, etc. The ECO is compatible with the SBE 19 SeaCAT, 19*plus* SeaCAT, 19*plus* V2 SeaCAT, 25 Sealogger, and 25*plus* Sealogger CTD.

**PCB** – Printed Circuit Board.

**Note:**

All Sea-Bird software listed was designed to work with a computer running Windows XP service pack 2 or later, Windows Vista, or Windows 7.

**SBE Data Processing** – Sea-Bird’s Win 2000/XP data processing software, which calculates and plots temperature, conductivity, pressure, and auxiliary sensor data, and derived variables such as salinity and sound velocity.

**Scan** – One data sample containing temperature, conductivity, pressure, and optional auxiliary inputs.

**Seasave V7** – Sea-Bird’s Windows software used to acquire, convert, and display real-time or archived raw data.

**Seasoft V2** – Sea-Bird’s complete Windows software package, which includes software for communication, real-time data acquisition, and data analysis and display. Seasoft V2 includes *Seaterm*, *SeatermAF*, *SeatermV2*, *Seasave V7*, *SBE Data Processing*, and Plot39.

**Seaterm** – Sea-Bird’s Windows terminal program used to communicate with the SBE 33 Deck Unit and the SBE 19, 19*plus*, or 25 CTD to set up the instruments.

**SeatermAF** – Sea-Bird’s Windows software used to communicate with the ECO and with a CTD (SBE 19, 19*plus*, 19*plus* V2, 25, or 25*plus* CTD) connected to the ECO.

**SeatermV2** – Windows terminal program *launcher*. Depending on the instrument selected, it launches Seaterm232 (RS-232 instruments), Seaterm485 (RS-485 instruments), or SeatermIM (inductive modem instruments).







**Seaterm232** – Windows terminal program used with Sea-Bird instruments that communicate via an RS-232 interface, and that were developed or redesigned in 2006 and later. The common feature of these instruments is the ability to output status information in XML. Seaterm232 is used with the SBE 19*plus* V2 and 25*plus*.

**Super O-Lube** – Silicone lubricant used to lubricate O-rings and O-ring mating surfaces. Super O-Lube can be ordered from Sea-Bird, but should also be available locally from distributors. Super O-Lube is manufactured by Parker Hannifin ([www.parker.com/ead/cm2.asp?cmid=3956](http://www.parker.com/ead/cm2.asp?cmid=3956)).



## Safety and Electrical Symbols

Some or all of the following symbols may be used on the SBE 55:

Symbol	Description
	Potentially hazardous voltage.
	Hazardous! Voltage > 30 VDC may be present.
	Attention! There is a potential hazard; consult the manual before continuing.
	DC (Direct Current).
	Double insulated. The metal enclosure of the SBE 55 is isolated such that protection from electrical shock is provided through reinforced electrical insulation.
	Static awareness. Static discharge can damage part(s).
	Protective earthing terminal.

# Appendix I: Making and Rigging Lanyards



Lanyards are made from heavy-weight nylon monofilament, 2 mm (0.080 inch) diameter. Monofilament used for gasoline-powered line trimmers (*weed eaters*) is suitable and readily available at most home and garden stores.

Lanyard loops are made with crimped copper sleeves (nico-press type). Available from Sea-Bird or from industrial suppliers, the copper sleeves can be installed with pliers made for crimping on soldered electrical connections. If copper sleeves or similar products are unavailable, the monofilament may be knotted; take care that there are no loose ends or large knots that may jam or hang up and hinder bottle closure.

To cock the lanyards in preparation for deployment, see *Lanyard Rigging and Cocking* in *Section 3: Mechanically Preparing ECO for Deployment*.

**Use the instructions in this appendix as a guideline; there may be some trial and error in fitting the lanyards properly.**

Before you start, verify that the bottle orientation on the frame is correct and that the internal bands in the bottle are straight, as shown in the photos.

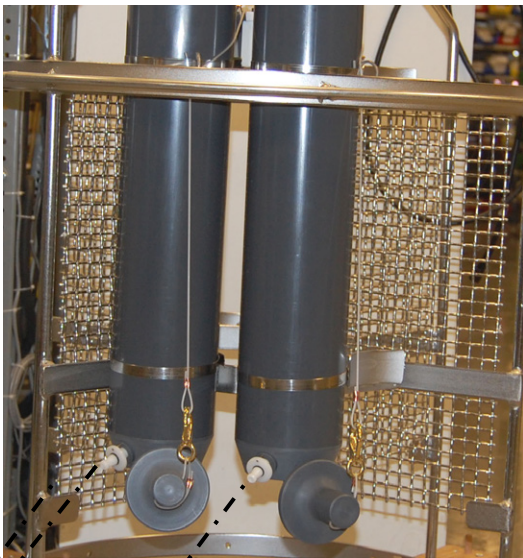
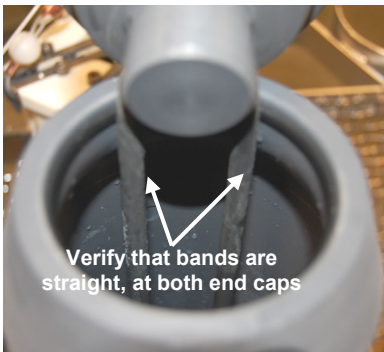

For *middle* bottle in group of 3 bottles, place bottle so that drain fitting is parallel to drain fitting on one of end bottles.

Place *end* bottles so that drain fitting is approximately parallel to adjacent frame, to avoid interference with lower end cap when cocked.

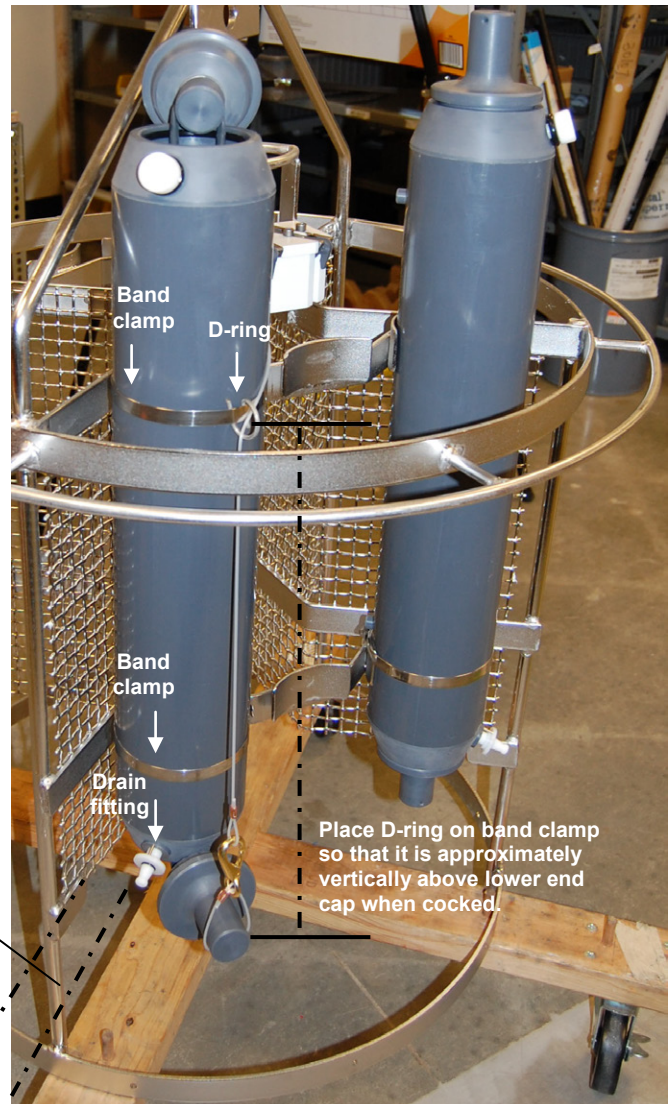

Place D-ring on band clamp so that it is approximately vertically above lower end cap when cocked.

Latch with standard plastic side bars



Latch with optional titanium side bars



CAUTION: Some customers use aircraft wire in place of the recommended nylon monofilament lanyards. **Do not use aircraft wire on a Carousel with latches with standard plastic side bars**; aircraft wire will damage the plastic side bars.

## Lower Lanyard

1. Cut a piece of lanyard material to 20.3 cm (8 inches).

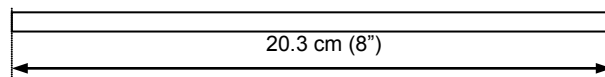

2. Thread the lanyard through the hole in the bottom end cap.
3. Thread the lanyard through the hole in a brass snap hook.
4. Thread the ends of the lanyard through a nico-press sleeve in opposite directions. Pull the lanyard material through until you have a 5.1 cm (2") diameter circle. Crimp the sleeve.
5. Cut excess lanyard material next to the sleeve at a 45-degree angle to make a smooth termination, with approximately 0.7 cm (0.25") of lanyard extending in each direction beyond the sleeve.
6. Move the loop around on the lower end cap until the sleeve is next to the end cap. Pull straight out on the hook to help the lanyard take the desired set.

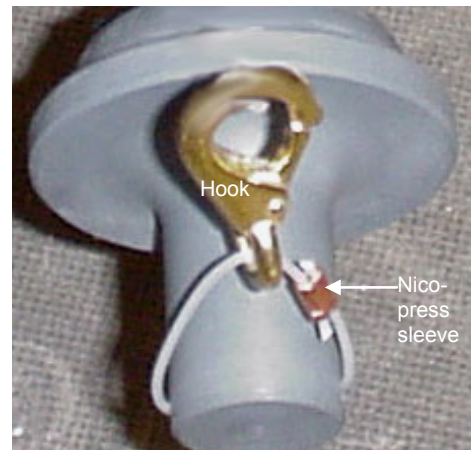
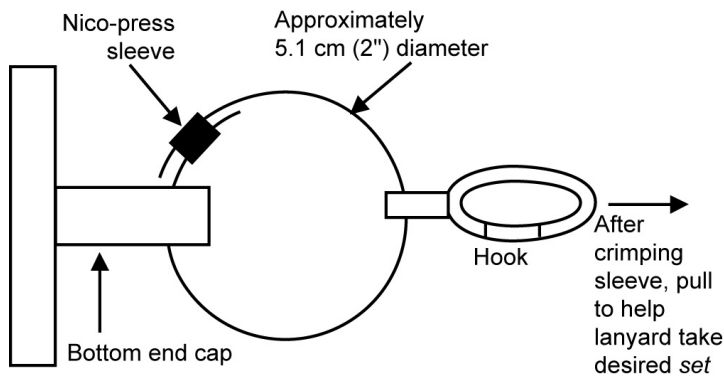



### Upper Lanyard

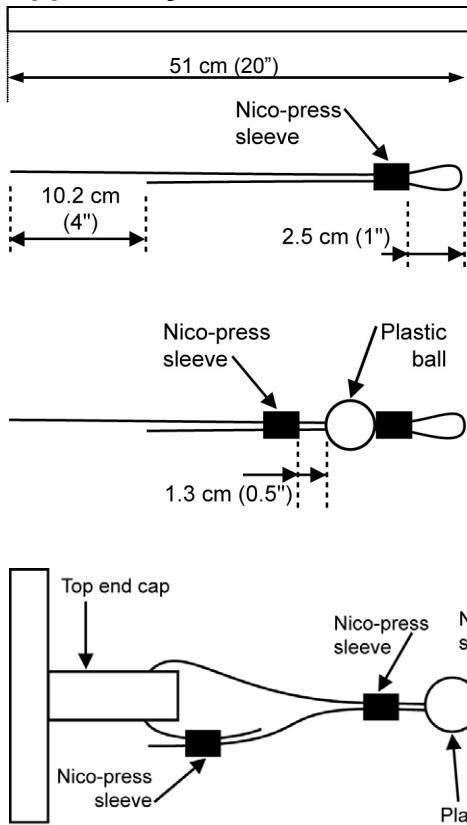

1. Cut a piece of lanyard material to 51 cm (20").
2. Thread both ends of the lanyard through a nico-press sleeve, leaving a 2.5 cm (1") loop (this loop will hook onto the trigger). Adjust the lanyard ends so that one end hangs below the other by 10.2 cm (4"). Crimp the sleeve.
3. Thread both ends of the lanyard through the hole in the plastic lanyard ball and work the ball up on the lanyard until it rests against the nico-press sleeve.
4. Thread both ends of the lanyard through a nico-press sleeve; place the sleeve 1.3 cm (0.5") from the end of the plastic ball. Crimp the sleeve.
5. Thread the longer end of the lanyard through the hole in the top end cap, and then thread the ends of the lanyard through a nico-press sleeve in opposite directions. **Do not crimp the sleeve yet.**

6. Open the top bottle end cap. Place a 5.1 cm (2 inch) wide wooden spacer in the top bottle mouth for safety. Hold the end cap in the correct *cocked* position, at approximately 90° (but not more) from the bottle. Place the lanyard loop over the *football*-shaped frame and onto the appropriate trigger. Press the trigger to lock in place. Pull on the loose ends of the lanyard until snug, and then crimp the sleeve.
7. Cut excess lanyard material next to the sleeve at a 45-degree angle to make a smooth termination, with approximately 0.7 cm (0.25") of lanyard extending in each direction beyond the sleeve.

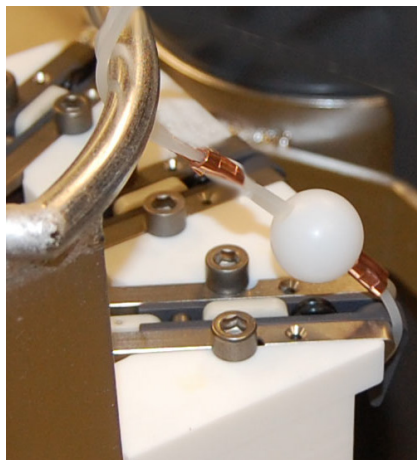

Attach upper lanyard to trigger. Press trigger to lock it in place.

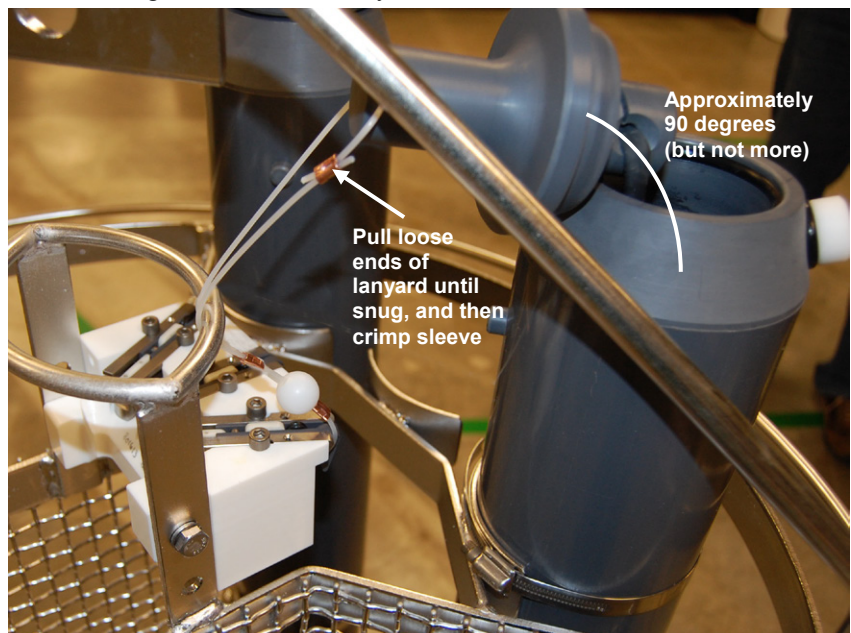

## Middle Lanyard

The middle lanyard connects the upper and lower lanyards.

1. Open both bottle end caps, with the top cap in the position described above, and the bottom cap angled toward the outside of the ECO. Place a 5.1 cm (2 inch) wide wooden spacer in each bottle mouth for safety:
  - A. Place the upper lanyard's loop over the *football*-shaped frame and onto the trigger so that it is in its *cocked* position.
  - B. Verify that the bottle end caps are cocked at the correct angles, and that the internal bands are straight.

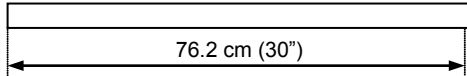

2. Cut a piece of lanyard material to 76.2 cm (30 inches).

3. Thread one end of the lanyard through the upper lanyard, in the space between the plastic ball and the nico-press sleeve. Thread both ends of the lanyard through a nico-press sleeve, leaving a 1.0 cm (0.4") loop and 0.7 cm (0.25") at one end of the lanyard extending beyond the sleeve. Crimp the sleeve.

4. Thread the end of the middle lanyard up and over the *football*-shaped frame.

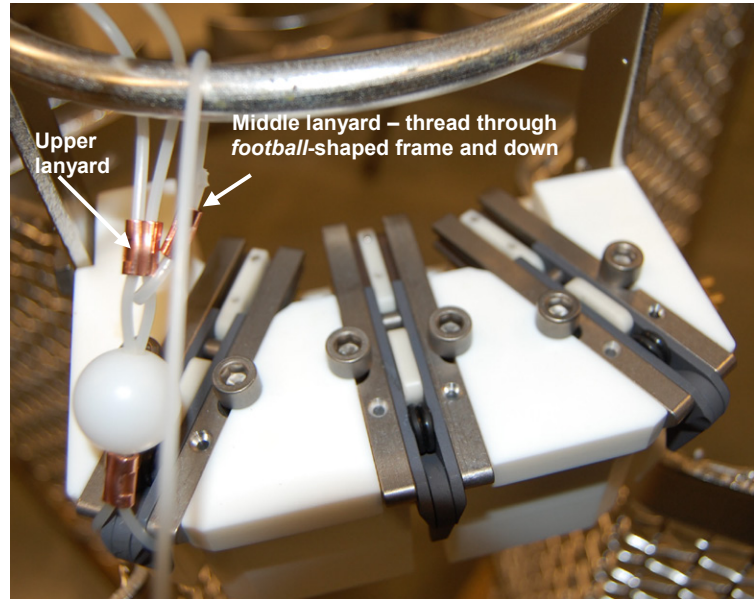
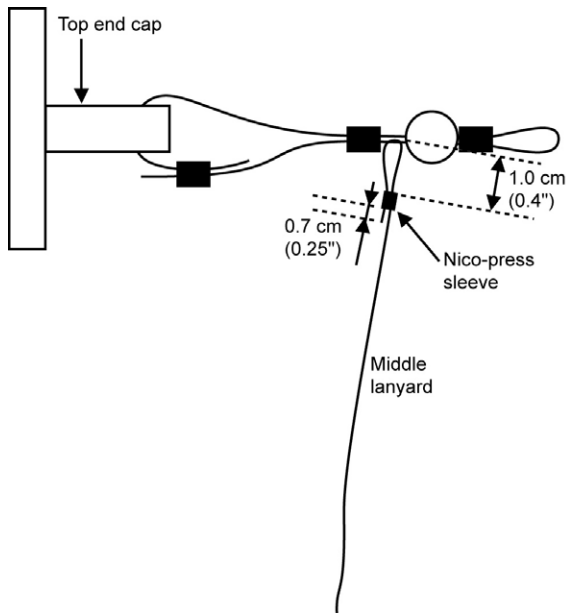

5. Thread the end of the middle lanyard through the D-ring on the outside of the top band clamp on the bottle.
6. Thread the end of the middle lanyard through a nico-press sleeve. Thread the middle lanyard through the lower lanyard snap hook, and thread the free end of the lanyard through the other side of the nico-press sleeve, leaving a 2.5 cm (1") loop.

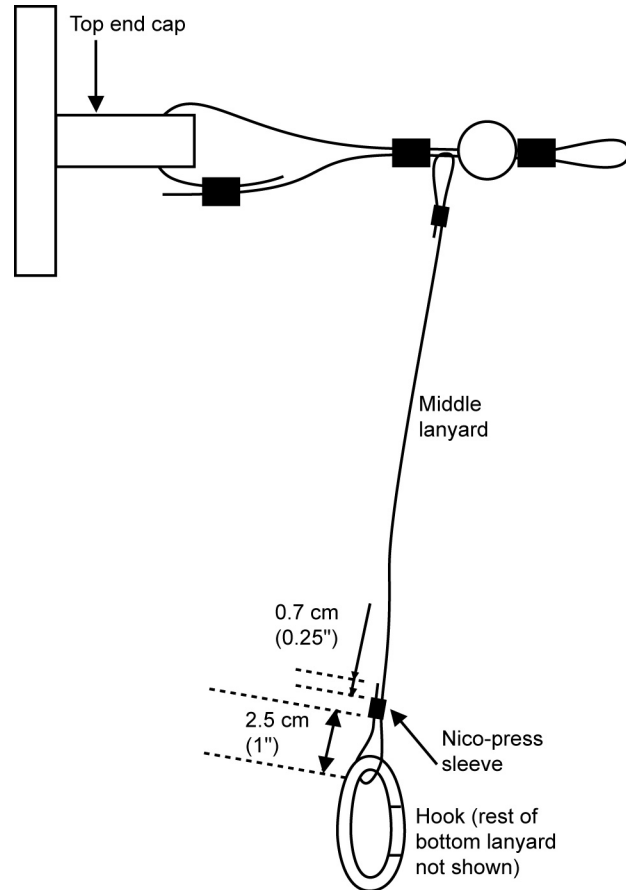
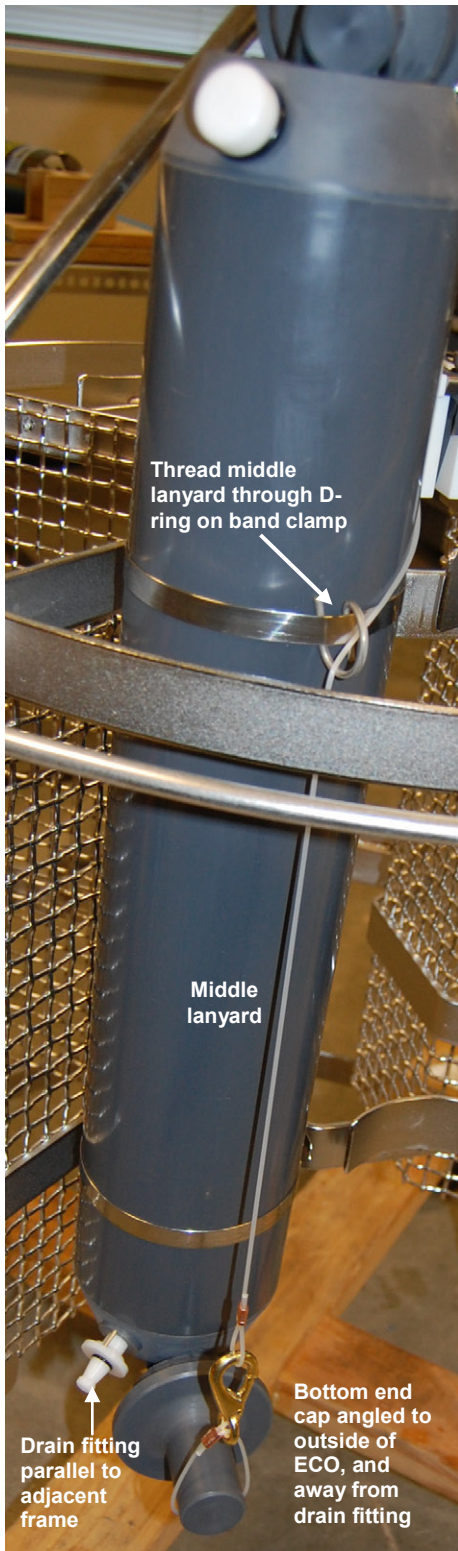

7. With both end caps cocked to 90°, pull on the loose end of the lanyard until it takes up the tension on the bottom end cap, and then crimp the sleeve. Cut excess lanyard material next to the sleeve at a 45-degree angle to make a smooth termination, with approximately 0.7 cm (0.25") of lanyard extending in each direction beyond the sleeve.
8. Remove the wooden spacers. Both end caps should be held in the proper *cocked* position. If not, remake the middle lanyard, adjusting the length as required.



# Appendix II: Electronics Control Module Disassembly/Reassembly

Remove the Electronics Control Module (ECM) from its band clamp mounting on the ECO before beginning.

Jackscrew kit



Sea-Bird provides a jackscrew kit with the SBE 55, to assist in removal of the ECM connector end cap. The kit contains:

- Two Allen wrenches
- Three jackscrews
- Two spare plastic socket hex-head screws

## Disassembly

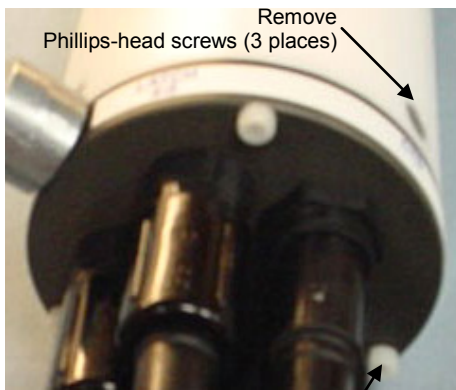

Remove plastic hex-head screws and install jackscrews in their place (3 places)

1. Wipe the outside of the connector end cap and housing dry, being careful to remove any water at the seam between them.
2. Remove the end cap and electronics:
  - A. Remove the three Phillips-head screws securing the end cap to the housing.
  - B. Remove the three plastic hex-head screws from the end cap using the larger Allen wrench. Insert the three jackscrews in these three holes in the end cap. When you begin to feel resistance, use the smaller Allen wrench to continue turning the screws. Turn each screw  $\frac{1}{2}$  turn at a time. As you turn the jackscrews, the end cap will push away from the housing. When the end cap is loosened, pull it and the PCB assembly out of the housing.
  - C. Remove any water from the O-ring mating surfaces inside the housing with a lint-free cloth or tissue. Be careful to protect the O-rings from damage or contamination.
  - D. Disconnect the Molex connectors connecting the PCB assembly to the Electronics Control Module.
  - E. Remove the jackscrews from the end cap.

## Reassembly

1. Remove any water from the O-ring and mating surfaces with a lint-free cloth or tissue. Inspect the O-ring and mating surfaces for dirt, nicks, and cuts. Clean or replace as necessary. Apply a light coat of O-ring lubricant (Parker Super O Lube) to O-ring and mating surfaces
2. Reconnect the Molex connectors to the PCB assembly. Verify the connectors hold and pins are properly aligned
3. Carefully fit the PCB assembly into the housing, aligning the holes in the end cap and housing.
4. Reinstall the three Phillips-head screws to secure the end cap to the housing.
5. Reinstall the three plastic hex head screws in the end cap.

### Note:

Before delivery, a desiccant package is inserted in the housing, and the electronics chamber is filled with dry Argon gas. These measures help prevent condensation. To ensure proper functioning:

1. Install a new desiccant bag each time you open the electronics chamber. If a new bag is not available, see *Application Note 71: Desiccant Use and Regeneration (drying)*.
2. If possible, dry gas backfill each time you open the housing. If you cannot, wait at least 24 hours before redeploying, to allow the desiccant to remove any moisture from the housing.

# Appendix III: Replacement Parts

**Note:**

SBE 19 and 25 CTDs configured with a pump, and all SBE 19*plus* V2 and 25*plus* CTDs, have a 6-pin data I/O – pump connector. These CTDs are supplied with a Y-cable (6-pin to CTD, 4-pin I/O, 2-pin pump); connect the ECO-CTD cable (172259 or 172260) to the 4-pin data I/O connector on the Y-cable.

Part Number	Part	Application Description	Quantity in ECO
22018	Alkaline D-cells, Duracell MN 1300 (LR20)	Batteries to power ECO	9
41124B	Battery cover plate	Retains alkaline batteries	1
801511	NiMH battery pack	Optional rechargeable 9-cell battery pack	-
90504	NiMH battery charger	For NiMH batteries	-
172302*	6-pin AG-206 to 4-pin RMG-4MP, 0.8 m (2.5 ft)	Data I/O cable extender	1
801436*	4-pin RMG-4FS to 9-pin DB-9S, 20 m (66 ft)	From data I/O cable extender to computer (test, setup, and upload)	1
17088*	4-pin RMG-4FS to 4-pin RMG-4FS, 1.1 m (3.8 ft)	From ECO's Electronics Control Module to ECO's latch assembly	1 or 2
172259*	6-pin AG-206 to 4-pin RMG-4FS, 1.2 m (4 ft)	From ECO's Electronics Control Module to SBE 19, 19 <i>plus</i> , 19 <i>plus</i> V2, 25, 25 <i>plus</i> , or 49	-
80915*	2-pin RMG-2FS to 2-pin MS3106A-12S-3P, 10 m (33 ft)	From ECO's Electronics Control Module to SBE 33 (test cable)	1
17120*	2-pin RMG-2FS to 2-pin RMG-2MP sea cable extension, 2 m (6.6 ft)	From ECO's Electronics Control Module to winch cable	-
172303	6-pin MCIL-6FS ( <b>wet-pluggable</b> ) to 4-pin MCIL-4MP, 0.8 m (2.5 ft)	Data I/O cable extender	
801460	4-pin MCIL-4FS ( <b>wet-pluggable</b> ) to 9-pin DB-9S, 20 m (66 ft)	From data I/O cable extender to computer (test, setup, and upload)	1
171792	4-pin MCIL-4FS to 4-pin MCIL-4FS ( <b>wet-pluggable</b> ), 1.1 m (3.8 ft)	From ECO's Electronics Control Module to ECO's latch assembly	1 or 2
172260	6-pin MCIL-6FS to 4-pin MCIL-4FS ( <b>wet-pluggable</b> ), 1.2 m (4 ft)	From ECO's Electronics Control Module to SBE 19, 19 <i>plus</i> , 19 <i>plus</i> V2, 25, 25 <i>plus</i> , or 49	-
801587	2-pin MCIL-2FS to 2-pin MS3106A-12S-3P ( <b>wet-pluggable</b> ), 10 m (33 ft)	From ECO's Electronics Control Module ( <b>wet-pluggable</b> connectors) to SBE 33 (test cable)	-
171743	2-pin MCIL-2FS to 2-pin MCIL-2MP ( <b>wet-pluggable</b> ) sea cable extension, 2 m (6.6 ft)	From ECO's Electronics Control Module to winch cable	-
17044.1*	2-pin RMG-2FSD-LP dummy plug and locking sleeve	For when 2-pin connector not used	1
17046.1*	4-pin RMG-4FSD-LP dummy plug and locking sleeve	For when 4-pin connector not used	3 or 4
17047.1*	6-pin AG-206FSD-LP dummy plug and locking sleeve	For when 6-pin connector not used	2

\* For standard Impulse glass-reinforced epoxy bulkhead connectors

Continued on next page



Continued from previous page

Part Number	Part	Application Description	Quantity in ECO
171497.1	2-pin MCDC-2-F dummy plug and locking sleeve	For when 2-pin connector not used (wet-pluggable connector)	1
171398.1	4-pin MCDC-4-F dummy plug and locking sleeve	For when 4-pin connector not used (wet-pluggable connector)	3 or 4
171498.1	6-pin MCDC-6-F dummy plug and locking sleeve	For when 6-pin connector not used (wet-pluggable connector)	2
50422	Spare CTD / Electronics mounting hardware kit	Hardware required to mount ECM or SBE 19, 19 <i>plus</i> , 19 <i>plus</i> V2, 25, 25 <i>plus</i> CTD on ECO, including: <ul style="list-style-type: none"> <li>• 233364.01 Mount blocks for 4-inch housings</li> <li>• 30379 Hose clamps, SS, #80 (secure housing and mount block to wire mesh)</li> <li>• 31138 Bolts ¼-20 x ¾ Hex head, SS (secure mount block to wire mesh)</li> <li>• 30253 Washers, ¼ Fender, SS, 1 in. OD (use with 31138)</li> <li>• 30409 Teflon tape, 1 inch wide (electrical insulation for hose clamps)</li> </ul>	-
50421	Spare frame assembly hardware kit	Including: <ul style="list-style-type: none"> <li>• 30360 Bolt, ¼-20 x 1 inch, Hex, SS (secure wire mesh to ECO frame)</li> <li>• 30216 Nut, ¼-20 Nylon stop, SS (for 30360 bolt)</li> <li>• 30253 Washer, ¼ Fender, SS, 1-inch OD (secure CTD or sensor mount to wire mesh; also for 30360 bolt)</li> </ul>	-
60021	Spare battery end cap hardware and o-ring kit	Hardware for Electronics Control Module battery end cap, including: <ul style="list-style-type: none"> <li>• 30145 Screw, 6-32 x 1/2 Phillips-head, stainless steel (secures battery cover plate to battery posts)</li> <li>• 30242 Washer, #6 flat, stainless steel (for screw 30145)</li> <li>• 30816 Parker 2-234E603-70 (battery end cap to housing piston seal, sensor end cap to housing seals)</li> <li>• 30090 Parker 2-153N674-70 (battery end cap to housing face seal)</li> </ul>	-
50429	SBE 55 Jackscrew Kit	For removing ECM connector end cap	1
50496	Spare standard plastic latch	To replace 1 latch	-
50299	Spare optional titanium latch	To replace 1 latch	-

Continued on next page

*Continued from previous page*

<b>Part Number</b>	<b>Part</b>	<b>Application Description</b>	<b>Quantity in ECO</b>
801714	ECO 4-liter water sample bottle	Water sample bottle designed for use on SBE 55	3 or 6
50430	ECO mounting and lanyard kit for 801714 bottle	Including: <ul style="list-style-type: none"> <li>• 233575 Lanyard Guide D-Ring (attaches to band clamp and routes middle lanyard)</li> <li>• 30664 Nicopress Oval Sleeves (for lanyards)</li> <li>• 31690 Monofilament line 0.080 inches OD (for lanyard)</li> <li>• 30772 Brass snap hook (for lanyard)</li> <li>• 30773 Plastic lanyard ball</li> <li>• 30988 Hose clamps, 316 SS, #80 (secure bottle to frame)</li> </ul>	
50424	Drain fitting kit for 801714 bottle	Including: <ul style="list-style-type: none"> <li>• 233589 Drain fitting barb (provides drain)</li> <li>• 233590 Drain fitting ring (attaches to barb and guide pin)</li> <li>• 30390 Parker 2-012 N674-70 (seals drain fitting)</li> </ul>	-
50425	Air bleed kit for 801714 bottle	Including: <ul style="list-style-type: none"> <li>• 233588 Air bleed port</li> <li>• 31649 Parker 2-312 N674-70 (seals air bleed valve)</li> </ul>	-
50426	O-ring kit for 801714 bottle	Including: <ul style="list-style-type: none"> <li>• 30390 Parker 2-012 N674-70 (seals drain fitting)</li> <li>• 31649 Parker 2-312 N674-70 (seals air bleed valve)</li> <li>• 31188 Parker 2-336 N674-70 (seals bottle caps to bottle)</li> </ul>	-
50427	Bottle repair kit for 801714 bottle	Including: <ul style="list-style-type: none"> <li>• 50426 O-ring kit</li> <li>• 50425 Air bleed kit</li> <li>• 50424 Drain fitting kit</li> <li>• 30773 Plastic lanyard ball</li> <li>• 30772 Brass snap hook (for lanyard)</li> <li>• 31690 Monofilament line 0.080 inches OD (for lanyard)</li> <li>• 30664 Nicopress Oval Sleeves (for lanyards)</li> <li>• 233650 latex rubber power cord (retains cap to bottle)</li> <li>• 233587 Water bottle cap</li> <li>• 233575 Lanyard Guide D-Ring (attaches to band clamp and routes middle lanyard)</li> </ul>	-

# Appendix IV: Manual Revision History

Manual Version	Date	Description
001	03/07	Initial release.
002	05/08	<ul style="list-style-type: none"> <li>• Firmware 1.2: Add compatibility with SBE 50 for autonomous bottle firing, add power on and power off commands (<b>DCDCOn</b>, <b>DCDCOff</b>) for testing firing.</li> <li>• Clarify that ECO can be used with SBE 19plus V2.</li> <li>• Add spares kits to replacement parts list.</li> <li>• Add extender cables (6-pin to 4-pin) for data I/O, change data I/O cable PNs.</li> <li>• Add photos showing ECO bottles, revised framing.</li> <li>• Update line art - revised framing, ECM connectors at bottom.</li> <li>• Add information that can upgrade firmware through the serial port for future changes.</li> <li>• Update maintenance information on connector for consistency with application note 57.</li> <li>• Note about CTD optical isolation that is standard in 25 &amp; optional in 19 (not plus) -- must be disabled only if providing external power; otherwise ok as is.</li> <li>• Update Appendix II to newer design, includes end cap with jackscrews.</li> <li>• Add note to keep ECO covered, especially latch assembly, when not in use, to avoid salt spray.</li> <li>• Add information on inspection and storing of bottles.</li> <li>• Add warning concerning potential for injury when testing bottle closure.</li> </ul>
003	02/10	<ul style="list-style-type: none"> <li>• Firmware 1.3: Stationary fire, DeepEnough, EnableStationary, and EnableUpCast logic now includes equality (<math>\geq</math> relevant value).</li> <li>• Correct information on Close on Upcast auto fire: Must meet pressure <b>and</b> change in pressure to enable upcast. If it never gets to pressure to enable upcast, it will not close any bottles.</li> <li>• Changes required for CE certification; add CE mark.</li> <li>• Update replacement parts.</li> <li>• SBE 33 NMEA Interface now standard, not optional.</li> <li>• Remove references to SCPlusV2_RS232 software, replaced with SeatermV2.</li> <li>• Update software names.</li> <li>• Seasave, SBE Data Processing 7.19: allows acquisition and processing of NMEA data for SBE 49.</li> <li>• Seasave &amp; SBE Data Processing 7.20a: Add information about .xmlcon file. Note that SeatermAF is not yet compatible with .xmlcon file, must continue to use .con file.</li> <li>• Update SBE address.</li> </ul>
004	05/10	<ul style="list-style-type: none"> <li>• Update lanyard procedures (making, rigging, and cocking).</li> <li>• Lithium battery replacement – add note that difficult to do, suggest you send to Sea-Bird.</li> </ul>
005	04/12	<ul style="list-style-type: none"> <li>• Add information on use with SBE 25<i>plus</i>.</li> <li>• Correct information on commands sent to 19<i>plus</i> or 19<i>plus</i> V2 when Diagnostics button on SeatermAF toolbar is used.</li> <li>• Add information on new latches.</li> <li>• Add maintenance information on bottle O-rings.</li> <li>• SBE Data Processing 7.20c: Update Bottle Summary Data Setup dialog box to reflect ability to enable/disable oxygen Tau correction.</li> <li>• SBE Data Processing 7.21a: Update Data Conversion Data Setup dialog box to reflect changes.</li> <li>• Add information that Ni-Cad battery pack and charger are no longer available.</li> <li>• Update end cap drawing to clarify that power for 19, 19<i>plus</i>, 19<i>plus</i> V2, 25, 25<i>plus</i>, or 49 is only supplied if seacable is connected.</li> <li>• Add information on compatibility with Windows 7.</li> </ul>
006	05/12	<ul style="list-style-type: none"> <li>• Update SeatermAF software description and use with SeatermAF V2.</li> <li>• Update schematic for use with SBE 33 Deck Unit; Surface PAR channel is now standard.</li> </ul>

Continued on next page

*Continued from previous page*

007	04/13	<ul style="list-style-type: none"><li>• Remove SBE 50 pressure sensor; not supported by SeatermAF or SeatermAF V2.</li><li>• SeatermAF V2 updates: Add information on use of View CTD button. Update Upload screen capture for SBE 25<i>plus</i>; update Upload &amp; Header Options dialog</li><li>• Add Declaration of Conformity.</li><li>• Add cable diagrams.</li><li>• Update software compatibility information.</li><li>• Update hose clamp part number.</li></ul>
-----	-------	--

# Index

---

- 
- .afm file · 60, 68
- .bl file · 66, 68
- .btl file · 71
- .cnv file · 68, 71
- .con file · 28, 35, 37, 63, 68
- .hex file · 61, 66, 68
- .ini file · 25
- .psa file · 25
- .ros file · 68, 71
- .xml file · 68
- .xmlcon file · 28, 35, 37, 63, 68

---

## A

- Auto-fire · 9
- Autonomous operation · 9, 24

---

## B

- Band clamp · 16
- Batteries
  - alkaline · 74
  - Ni-Cad · 77
  - NiMH · 75
  - recharging · 75, 77
  - replacing · 74
- Battery endurance · 12
- Baud rate · 29
- Bottle closure setup · 34
- Bottles · 73
  - mounting · 16
- Bulkhead connectors · 12

---

## C

- Cables · 14
- CE certification · 3
- Clamp · 16
- Cleaning · 72
- Close on downcast · 37
- Close on elapsed time · 41
- Close on upcast · 35
- Close when stationary · 39
- Commands · 23
  - Auto Fire arm/disarm · 45
  - Auto Fire downcast and upcast logic setup · 48
  - Auto Fire general setup · 47
  - Auto Fire stationary logic setup · 48
  - Auto Fire time-based logic setup · 48
  - data upload · 45
  - date and time · 45
  - descriptions · 43
  - general setup · 47
  - sleep · 46
  - status · 43
  - testing · 46

- Communication defaults · 29
- Configuration file · 28
- Configurations · 9
- Connectors · 12, 73
- Corrosion precautions · 72
- Covering ECO · 73
- CTD
  - mounting · 17

---

## D

- Data bits · 29
- Data formats · 60, 61, 66
- Data output formats · 66
- Data processing
  - SBE 19 · 67
  - SBE 19plus · 67
  - SBE 19plus V2 · 67
  - SBE 25 · 67
  - SBE 25plus · 67
- Declaration of Conformity · 3
- Deployment · 49, 63
  - autonomous · 24
  - preparing for · 16
  - real-time · 62
- Description · 7
- Dimensions · 12
- Downcast · 37

---

## E

- Elapsed time · 41
- Electrical symbols · 80
- Electronics disassembly/reassembly · 86
- End cap · 73, 74

---

## F

- Format
  - data · 60, 61, 66
  - data output · 66

---

## G

- Glossary · 79

---

## H

- Hose clamp · 16

---

## L

- Lanyards · 18, 81
- Latch replacement · 78

---

**M**

Maintenance · 72  
 Manual revision history · 90  
 Mounting bottles · 16  
 Mounting CTD · 17

---

**O**

Operation  
   autonomous · 24  
   real-time · 62

---

**P**

Parity · 29  
 Parker Super O-Lube · 79  
 Parts  
   replacement · 87  
 Power endurance · 12  
 Processing data  
   SBE 19 · 67  
   SBE 19plus · 67  
   SBE 19plus V2 · 67  
   SBE 25 · 67  
   SBE 25plus · 67

---

**R**

Real-time operation · 10, 62  
 Recovery  
   physical handling · 51  
   uploading data · 52  
 Recovery · 51  
 Recovery · 65  
 Replacement parts · 87  
 Revision history · 90

---

**S**

Safety symbols · 80  
 Sasoft · 63  
 SBE 19 CTD · 9, 10, 24, 61, 62, 66  
 SBE 19plus CTD · 9, 10, 24, 61, 62, 66  
 SBE 19plus V2 CTD · 9, 10, 24, 61, 62, 66  
 SBE 25 CTD · 9, 10, 24, 61, 62, 66  
 SBE 25plus CTD · 9, 10, 24, 61, 62, 66  
 SBE 33 Deck Unit · 10, 62  
 SBE 49 CTD · 10, 62  
 SBE Data Processing · 8, 22, 59, 64, 67  
 Seasave · 8, 22, 63  
 Seasoft · 8, 22, 25  
 Seaterm · 8, 22, 63  
 SeatermAF · 24, 25  
   main screen · 25  
   toolbar buttons · 27  
 SeatermAF V2 · 8, 22  
   communication defaults · 29  
   configuration options · 28  
 SeatermV2 · 8, 22  
 Serial port · 29  
 Setup · 24  
 Software · 8  
   installation · 22  
 Specifications · 11  
 Stationary · 39  
 Storage · 73  
 Super O-Lube · 79  
 System description · 7

---

**T**

Testing · 24  
 Time · 41  
 Tubing · 73

---

**U**

Unpacking ECO · 6  
 Upcast · 35  
 Uploading data · 52

---

**V**

Versions · 90

---

**W**

Wiring · 14, 49, 62