

# SeaCAT / Sealogger RS-232 and Navigation Interface Box

*AC-Powered Version: Part Number 90488*

*DC-Powered Version: Part Number 90545*



## User's Manual

Sea-Bird Electronics, Inc.  
13431 NE 20<sup>th</sup> Street  
Bellevue, Washington 98005 USA  
Telephone: +1 425-643-9866  
Fax: +1 425-643-9954  
E-mail: seabird@seabird.com  
Website: www.seabird.com

**Manual Version #016, 09/30/13**  
**Firmware Version 3.1b and later**  
**Seasave V7 Version 7.23.1 and later**  
**SBE Data Processing Version 7.23.1 and later**



# Limited Liability Statement

Extreme care should be exercised when using or servicing this equipment. It should be used or serviced only by personnel with knowledge of and training in the use and maintenance of oceanographic electronic equipment.

SEA-BIRD ELECTRONICS, INC. disclaims all product liability risks arising from the use or servicing of this system. SEA-BIRD ELECTRONICS, INC. has no way of controlling the use of this equipment or of choosing the personnel to operate it, and therefore cannot take steps to comply with laws pertaining to product liability, including laws which impose a duty to warn the user of any dangers involved in operating this equipment. Therefore, acceptance of this system by the customer shall be conclusively deemed to include a covenant by the customer to defend, indemnify, and hold SEA-BIRD ELECTRONICS, INC. harmless from all product liability claims arising from the use or servicing of this system.

# Declaration of Conformity

Sea-Bird Electronics, Inc.  
13431 NE 20<sup>th</sup> Street, Bellevue, WA 98005 USA

## DECLARATION OF CONFORMITY

**Manufacturer's Name:** Sea-Bird Electronics  
**Manufacturer's Address:** 13431 NE 20<sup>th</sup> Street  
Bellevue, WA 98005, USA

**The Authorized Representative located within the Community is:**  
OTT MESSTECHNIK GmbH & Co.KG  
P.O.Box: 2140 / 87411 Kempten / Germany  
Ludwigstrasse 16 / 87437 Kempten  
Internet: <http://www.ott.com>  
Phone: +49 831 5617 – 100  
Fax: +49 831 5617 - 209

**Device Description:** Various Data Acquisition Devices and Sensors

### Model Numbers:

3S	3F	3plus	4C	4M	5T	5P	5M	7
8	9plus	11plus	14	16plus V2	16plus-IM V2		17plus V2	18
19plus V2	21	25plus	26plus	27	29	32	32C	32SC
33	35	35RT	36	37-IMP	37-IM	37-SMP	37-SM	37-SIP
37-SI	38	39	39-IM	39plus	41	41CP	43	43F
44	45	49	50	52-MP	53BPR	54	55	56
63	SIM	ICC	IMM	PDIM	AFM	90488	90204	90402
90504	Glider Payload CTD		NiMH Battery Charger and Battery Pack					

**Applicable EU Directives:** Machinery Directive 98 / 37 /EC  
EMC Directive 2004 / 108 /EC  
Low Voltage Directive (73 / 23 /EEC) as amended by (93 / 68 /EEC)

### Applicable Harmonized Standards:

EN 61326-1:2006 Class A Electrical Equipment for Measurement, Control, and Laboratory Use, EMC Requirement – Part 1: General Requirements  
(EN 55011:2007 Group 1, Class A)

EN 61010-1:2001, Safety Requirements for Electrical Equipments for Measurement, Control, and Laboratory Use – Part 1: General Requirements

Declaration based upon compliance to the Essential Requirements and Letter of Opinion from CKC Certification Services, LLC., Notified Body 0976

I, the undersigned, hereby declare that the equipment specified above conforms to the above European Union Directives and Standards.

Authorized Signature:

Name: Nordeen Larson

Title of Signatory: President

Date: 3 September 2013

Place: Bellevue, WA

# Table of Contents

<b>Limited Liability Statement</b> .....	<b>2</b>
<b>Declaration of Conformity</b> .....	<b>3</b>
<b>Table of Contents</b> .....	<b>4</b>
<b>Section 1: Introduction</b> .....	<b>5</b>
About this Manual .....	5
Unpacking Interface Box .....	6
<b>Section 2: Description of Interface Box</b> .....	<b>7</b>
System Description .....	7
Specifications .....	8
System Communications .....	9
Interface Box Connections, Switches, LEDs, and Fan .....	10
Cables .....	11
NMEA Operation.....	12
<b>Section 3: Setting Up System</b> .....	<b>13</b>
Installing Software .....	13
Setting Up and Testing System.....	13
Changing Communication Settings between Interface Box and Computer .....	17
Troubleshooting NMEA Interface .....	18
Problem 1: Yellow <i>RX NMEA</i> LED Not Flashing.....	18
Problem 2: Yellow <i>RX NMEA</i> LED Flashing, but Lat/Lon Data Displaying Incorrectly .....	18
Setting Up CTD Configuration (.xmlcon or .con) File in Seasave .....	19
<b>Section 4: Operating System</b> .....	<b>21</b>
Acquiring Real-Time Data with Seasave .....	21
Uploading CTD Data from Memory.....	23
<b>Section 5: Routine Maintenance</b> .....	<b>24</b>
<b>Glossary</b> .....	<b>25</b>
Safety and Electrical Symbols .....	25
<b>Appendix I: NMEA Device Message and Data Formats</b> .....	<b>26</b>
Message Formats .....	26
Data Formats.....	27
<b>Appendix II: NMEA Message Simulation Program</b> .....	<b>28</b>
<b>Appendix III: Replacement Parts</b> .....	<b>30</b>
<b>Appendix V: Manual Revision History</b> .....	<b>31</b>
<b>Index</b> .....	<b>33</b>

# Section 1: Introduction

This section includes photos of a standard SeaCAT/Sealogger RS-232 and Navigation Interface Box shipment.

---

## About this Manual

This manual is to be used with the SeaCAT/Sealogger RS-232 and Navigation Interface Box. It is organized to guide the user from installation through operation. We've included specifications, setup and operation descriptions, and helpful notes throughout the manual.

Sea-Bird welcomes suggestions for new features and enhancements of our products and/or documentation. Please contact us with any comments or suggestions ([seabird@seabird.com](mailto:seabird@seabird.com) or 425-643-9866). Our business hours are Monday through Friday, 0800 to 1700 Pacific Standard Time (1600 to 0100 Universal Time) in winter and 0800 to 1700 Pacific Daylight Time (1500 to 0000 Universal Time) the rest of the year.

# Unpacking Interface Box

Shown below is a typical Interface Box shipment.



Interface Box



AC power cable



OR

DC power connector



I/O Cable  
(Interface Box to computer)



I/O Cable  
(CTD to Interface Box)



4-pin RMG-4FS pigtail with locking sleeve (from CTD to SeaCAT data I/O connector on Interface Box)



4-pin MS connector (for SeaCAT data I/O connector on Interface Box)



NMEA Interface test cable (Interface Box to NMEA device simulation computer)



5-pin MS connector (for NMEA Input connector on Interface Box)



Software, and Electronic Copies of Software Manuals and User Manual

# Section 2: Description of Interface Box

This section describes the functions and features of the Interface Box, specifications, system communications, wiring, and NMEA operation.

## System Description

### Note:

For brevity, throughout the manual we refer to the instruments used with the Interface Box as *CTDs*, although the SBE 21 is a thermosalinograph, and the SBE 16, *16plus*, and *16plus V2* may not have a pressure sensor.

The SeaCAT/Sealogger RS-232 and Navigation Interface Box provides continuous isolated power (up to 1.5 Amps at 12 VDC) and an opto-isolated RS-232C interface to the SBE 16, *16plus*, *16plus V2*, 19, *19plus*, *19plus V2*, 21, or 25 CTD. It also provides an opto-isolated NMEA receiver and up to 2 Amps at 12 VDC to power a NMEA device, and an RS-232C computer interface.

### Notes:

For NMEA depth data (DBT or DPT):

- Depth data can be decoded and merged with CTD data only if NMEA position data (GGA, GLL, RMA, RMC, or TRF) is also available.
- Seasave (real-time data acquisition software) and SBE Data Processing (post-processing software) are compatible with NMEA depth data in the data stream for the SBE 19, *19plus*, *19plus V2*, 21, and 25.

The Box's NMEA interface merges NMEA data with CTD data. The Interface Box decodes messages that are output from devices supporting NMEA 0183 protocol, in one or more of the following formats:

- GGA - Global Positioning System Fix Data
- GLL - Geographic Position: Latitude/Longitude
- RMA - Recommended Minimum Specific Loran-C Data
- RMC - Recommended Minimum Specific GPS/TRANSIT Data
- TRF - TRANSIT Fix Data
- DBT – Depth Below Transducer
- DPT – Depth

Decoded NMEA data is appended to the CTD data stream in the Interface Box, and is passed to the computer for storage and/or display with the CTD data.

There are two versions of the Interface Box:

- **PN 90488** - universal 85-270 VAC input with frequency of 47-63 Hz
- **PN 90545**- 10-15 VDC input. The voltage input is also the voltage supply for the NMEA navigation device. Power to the navigation device is not a regulated voltage. **Do not exceed the input voltage specifications of the Interface Box; voltages above 15 VDC will cause severe damage to the NMEA navigation device.**

### Notes:

- Help files provide detailed information on the software.
- NMEATest, a NMEA device simulation program, is part of the SBE Data Processing installation.
- Separate software manuals on CD-ROM contain detailed information on Seasave V7 and SBE Data Processing.

This manual describes the general setup and operation of the Interface Box. Because the Interface Box is designed to work with several different Sea-Bird instruments, specific instrument responses may vary from what is shown.

The Interface Box is supplied with a powerful Windows software package, Seasoft V2, which includes:

- **Seaterm** and **SeatermV2** – terminal programs for easy setup.
- **Seasave V7** – program for acquiring, converting, and displaying real-time or archived raw data.
- **SBE Data Processing** – program for calculation and plotting of conductivity, temperature, pressure, auxiliary sensor data, and derived variables such as salinity and sound velocity.

## Specifications

<b>Input Power</b>	85-250 VAC / 47-63Hz / 1A (AC version); The Interface Box should always be used with a three-terminal outlet that includes a protective earth.  <b>or</b>  10-15 VDC (DC version)
<b>Output Power</b>	<i>To CTD:</i> 1.5 Amps at 12 VDC. <i>To NMEA device:</i> 2 Amps at 12 VDC (AC version) or input power (DC version). <i>Note:</i> Power to CTD is isolated from RS-232 interface and from power to NMEA device.
<b>Fuse</b>	5x20mm, 250VAC Slow-Blow, 1.25 Amp
<b>Dimensions</b>	200 x 121 x 76 mm (7.875 x 4.75 x 3 inch)
<b>Weight</b>	1.1 kg (2.5 lbs)
<b>Installation Conditions</b>	Interface Box operates properly under following conditions: <ul style="list-style-type: none"> <li>• Indoor use</li> <li>• Altitude up to 2000 meters</li> <li>• Temperature from 5 °C to 40 °C</li> <li>• Maximum relative humidity 80%, non-condensing</li> <li>• Mains supply voltage <math>\pm 10\%</math></li> </ul>



## System Communications

### Note:

Seasave also supports acquisition of data from a NMEA device connected directly to the computer (instead of the interface box) for the following instruments: SBE 19, 19*plus*, 19*plus* V2, 21, 25, and 49.

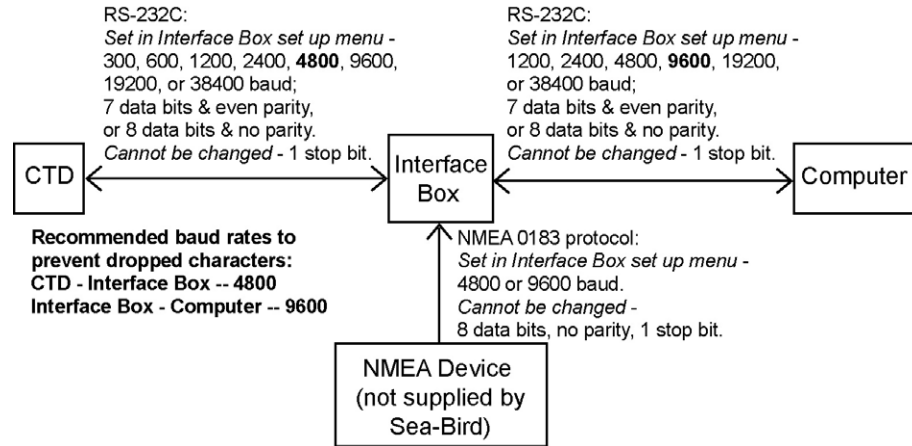

Communications notes:

### Note:

Older SBE 21s (firmware version less than 4.0a) communicate only at 9600 baud; set the baud rate between the CTD and Interface Box **and** the baud rate between the Interface Box and computer to 9600.

- **Baud rate between CTD and Interface Box** - must be set in both the CTD and the Interface Box. **To prevent dropped characters, set it to 4800 or less. The Interface Box factory default is 4800.** To set the baud rate in the CTD, see the CTD manual for the applicable command.

Note: The 19200 and 38400 baud rates are not recommended for normal operation. They are intended for use only in the following circumstances:

- If the CTD was initially set to 19200 or 38400 baud, and you want to reset the baud rate *in the CTD* while communicating through the Interface Box; or
- If updating SBE 21 firmware through the Interface Box (valid only for SBE 21 firmware  $\geq 5.0$ ), which requires 38400 baud in the SBE 21, in the Interface Box, and in the computer.

- **Baud rate between Interface Box and computer** – must be equal to or higher than the CTD baud rate. The Interface Box factory default is 9600.

Note: The 38400 baud rate is not recommended for normal operation. It is intended for use with the CTD baud rate of 19200 or 38400, as described above for the baud rate between the CTD and Interface Box.

- **Data bits and parity between CTD and Interface Box, and between Interface Box and computer are the same:**

SBE 16, 19, 21, and 25 - 7 data bits, even parity (factory default)

SBE 16*plus*, 16*plus* V2, 19*plus*, and 19*plus* V2 - 8 data bits, no parity

The Interface Box saves the user-input communication settings when powered down. The next time you apply power, it communicates using the last settings.

**To reset the Interface Box settings to factory defaults**, select *Send 5 second break* in Seaterm's Communications menu. The factory defaults are:

- 9600 baud for Interface box to computer
- 4800 baud for CTD to Interface Box
- 7 data bits, even parity (CTD to Interface Box, and Interface Box to computer)
- 4800 baud for NMEA device to Interface Box

## Interface Box Connections, Switches, LEDs, and Fan

Cables longer than 3 meters should be installed inside an earthed metal conduit by a qualified electrician. This minimizes the potential for external signals to disrupt communication and ensures that high voltage lines (such as the sea cable) are sufficiently protected. Cables shorter than 3 meters can be used without shielding when installing or bench testing the instrument.

### Connections:

- **SBE 21** – communications with and power to CTD (SBE 16, 16*plus*, 16*plus* V2, 19, 19*plus*, 19*plus* V2, 21, or 25). Connect Interface Box to CTD with MS3106A-14S-2P to RMG-4FS cable.

Interface Box	Function	CTD
A	Ground	1
B	Data receive by CTD from Interface Box	2
C	Data transmit from CTD to Interface Box	3
D	Optional power to CTD (12 VDC, 1.5 Amps)	4

- **NMEA** – communications with and power to NMEA device. Connect Interface Box to NMEA device with 5-pin MS connector (MS3106A-14S-5P).

Interface Box	Function
Pin A	Optional power return
Pin B	NMEA A (signal)
Pin C	NMEA B (signal return)
Pin D	No connection
Pin E	Optional power out (+12 VDC & 2 Amps for AC version; input power for DC version)

- **AC Input** (in photo below) - to standard, 3-prong, grounded, AC outlet, using UL/IEC-approved power cord (AC voltage between 85-270 VAC); **OR**  
**DC Input** (not shown) – from 2-pin female Amphenol connector (Pin A = ground, Pin B = power) to standard 10-15 VDC power supply.
- **Serial** – to computer using DB-9P to DB-9S cable.

Interface Box	Function
Pin 2	RS-232 data transmit to computer
Pin 3	RS-232 data receive from computer
Pin 5	Ground

### Power switch and LED –

Switch turns power to Interface Box on/off. Red LED turns on to indicate power is on.

### LEDs –

LEDs indicate if Interface Box is communicating with other parts of system:

- Green **RX SBE 21** LED - flashes when carriage return character (decimal 13) is received from CTD
- Yellow **TX SBE 21** LED - flashes when message is transmitted to CTD
- Yellow **RX NMEA** LED - flashes when carriage return character (decimal 13) is received from NMEA device

**Fan** – Ensure that the Interface Box, specifically the cooling fan and its vent, is not obstructed.

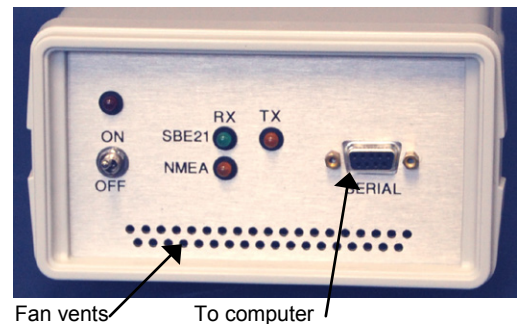
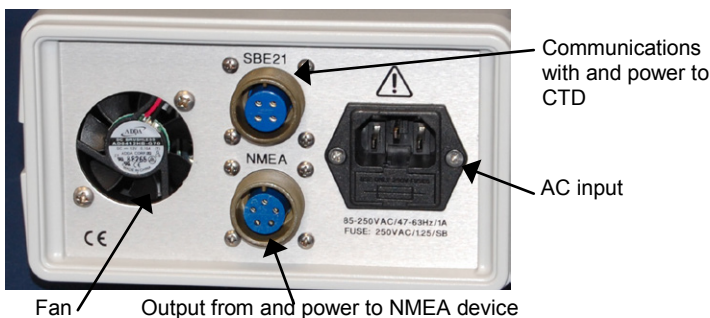

**Cables**

**MS3106 to RMG-4FS cable – SBE 21 connector on Interface Box to CTD**

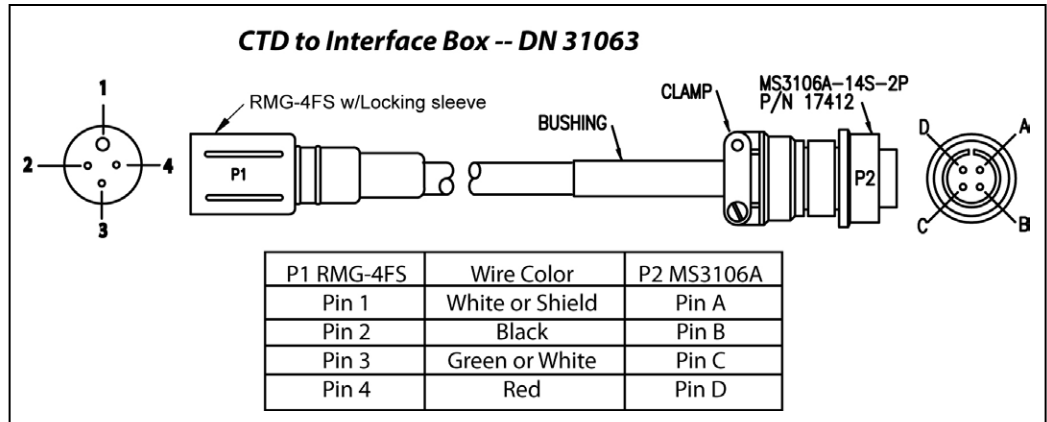

**DB9 to DB9 cable – Serial connector on Interface Box to computer**

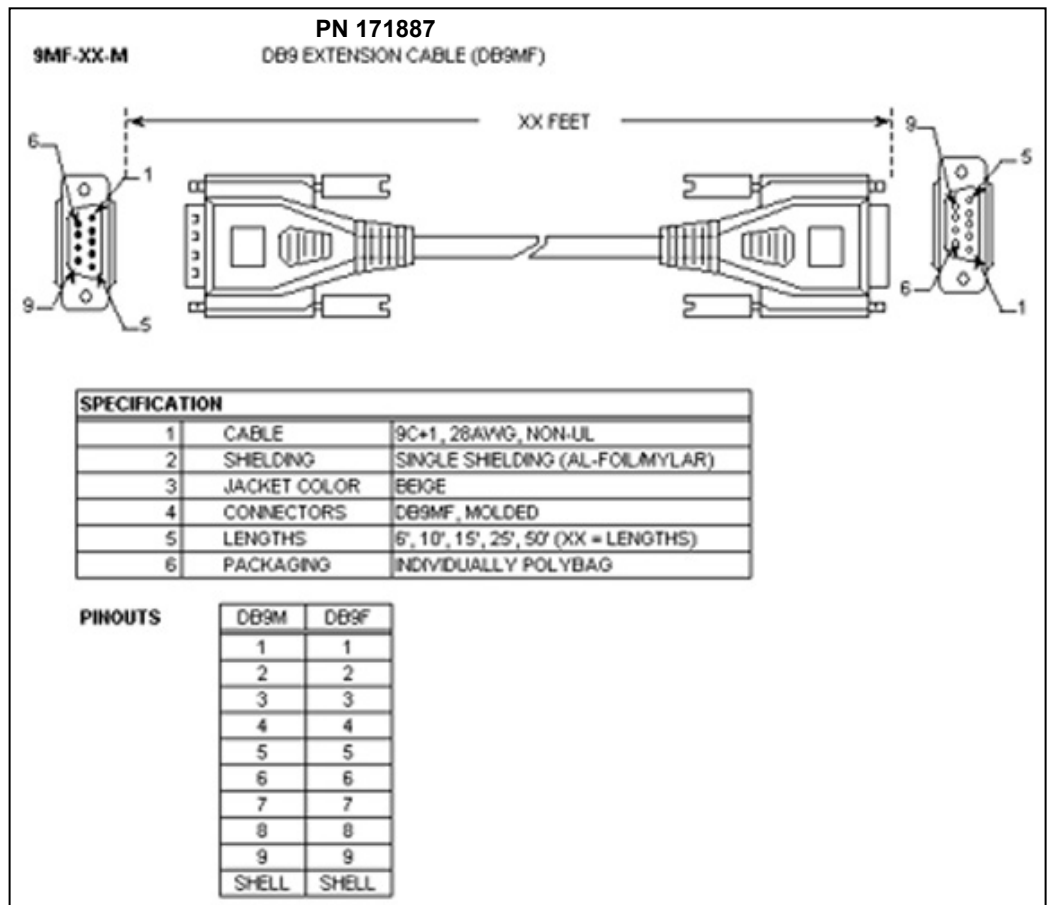

**5-pin to DB9 test cable – NMEA connector on Interface Box to computer**

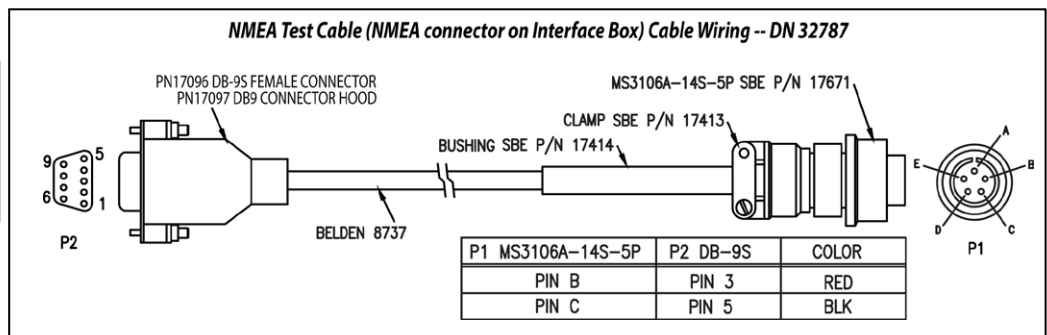

## NMEA Operation

The Interface Box includes a NMEA 0183 interface that permits NMEA data to be merged with the CTD data. The Interface Box is designed to decode messages that are output from devices supporting NMEA 0183 protocol.

Decoded NMEA data can be appended to the end of the CTD data stream in the Interface Box and passed to the computer for storage and/or display (see *Appendix I: NMEA Device Message and Data Formats*). The Yellow *RX NMEA* LED on the Interface Box flashes each time a NMEA message is received (should be same rate at which NMEA device is transmitting). The Interface Box appends the same NMEA message until a new message is decoded.

- *Example:* A NMEA device outputs its message once every 5 seconds. The Yellow *RX NMEA* LED flashes every 5 seconds, and the same message is appended to each scan of CTD data within that 5 seconds.

The Interface Box has three operating modes and two diagnostic modes, as well as two NMEA depth options, and selections for setting and displaying communication parameters and start-up behavior. Mode is selected in the setup menu while communicating with the Interface Box with Seaterm (see *Setting Up and Testing System* in *Section 3: Setting Up System*).

### Notes:

- In Seaterm, use the @ character to access and exit the setup menu.
- To enter diagnostic modes (8 and/or 9), first put the Interface Box in Mode 3. Then, enter an 8 or 9 at the mode selection prompt.
- To exit diagnostic modes (8 and/or 9), turn off power to the Interface Box.

Type	Mode	Description
Operating Modes	1: Echo only	Characters to and from CTD pass through Interface Box. No NMEA data is sent. Useful for setting up CTD without disconnecting CTD from system and connecting it directly to computer.
	2: Add Lat/Lon to hex data	Seven bytes of hex latitude/longitude data is added to each line of hex data from CTD. Used when position data is required with CTD data.
	3: Transmit Lat/Lon only	Data from CTD is not transmitted. Hex latitude/longitude data is converted to ASCII text whenever a new position is received from NMEA device. Format is: LAT 47 37.51 N LON 122 09.41 W  If NMEA message RMC is decoded, date and time display on next line. Format is: DDMMYY HHMMSS
NMEA Depth Options	4. Add NMEA Depth to real-time Hex/Lat/Lon data	Three bytes of depth data (for example, from a NMEA echo sounder) is added to each line of hex data from CTD, after lat/lon data.
	5. Do not add NMEA Depth to real-time Hex/Lat/Lon data	NMEA depth data is not added.
Communication Settings and Start Modes	6. Change communication settings and start mode	Set/reset baud rates, data bits, and parity, NMEA baud rate, and start mode (whether Interface Box starts in Operating Mode 1 or 2 when power applied).
	7. Display communication settings and start mode	Display settings set up in Mode 6.
Diagnostic	8 (diagnostic level 1): Transmit raw NMEA messages	All NMEA messages received are echoed to computer in <b>raw</b> form.
	9 (diagnostic level 2): Transmit decoded NMEA messages	All NMEA messages received are decoded by Interface Box and displayed on computer. If you select mode 8 and then select mode 9, the Interface Box transmits raw data followed by decoded data.

# Section 3: Setting Up System

This section covers:

- Installing Sea-Bird software
- Testing system
- Changing communication settings
- Troubleshooting NMEA interface
- Setting up CTD configuration (.xmlcon or .con) file

## Installing Software

### Notes:

- Help files provide detailed information on the software.
- NMEATest, a NMEA device simulation program, is part of the SBE Data Processing installation.
- Separate software manuals on CD-ROM contain detailed information on Seasave V7 and SBE Data Processing.

Seasoft V2 was designed to work with a PC running Windows XP service pack 2 or later, Windows Vista, or Windows 7.

If not already installed, install Sea-Bird software programs on your computer using the supplied software CD.

1. Insert the CD in your CD drive.
2. Install software: Double click on **SeasoftV2.exe**. Follow the dialog box directions to install the software. The installation program allows you to install the desired components. Install all the components, or just install Seaterm (terminal program), SeatermV2 (for use when directly communicating with an SBE 16*plus* V2 or 19*plus* V2), Seasave V7 (real-time data acquisition), and SBE Data Processing (data processing).

The default location for the software is c:\Program Files\Sea-Bird. Within that folder is a sub-directory for each component.

## Setting Up and Testing System

### Note:

The CTD must be connected to the Interface Box to test the NMEA interface. If it is not connected, noise on the open *SeaCAT Data I/O* connector will interfere with communication with the Interface Box.

### Note:

If using SBE 16*plus* V2, select SBE 16*plus*. If using SBE 19*plus* V2, select an SBE 19*plus*.

1. Double click on seaterm.exe. If this is the first time the program is used, the setup dialog box may appear:



Select the CTD you are using with the Interface Box, and the computer COM port for communication with the Interface Box. Click OK.

2. In the Configure menu, select the CTD you are using with the Interface Box (SBE 16, 16*plus*, 19, 19*plus*, 21, or 25).

- A. In the Configuration Options dialog box, click on the COM Settings tab and set the COM Settings:

- Comm Port - for RS-232C channel from Interface Box (1 through 10 as applicable)
- Baud rate between Interface Box and computer - 1200, 2400, 4800, 9600, 19200, or 38400 (factory set to 9600)
- Data bits and parity -  
SBE 16, 19, 21, or 25 - 7 data bits, even parity  
SBE 16*plus*, 16*plus* V2, 19*plus*, or 19*plus* V2 - 8 data bits, no parity

Click *OK* to save the settings and exit the dialog box.

**Note:**

Baud rate of 38400 between Interface Box and computer is not recommended for normal operation. See *System Communications in Section 2: Description of Interface Box* for details.

3. Turn on power to the Interface Box. The Interface Box status message displays in Seaterm:

Interface box V 3.1b setup:

PC baud rate = 9600

SEACAT baud rate = 4800

7 data bits, even parity

NMEA baud rate = 4800

start mode = Echo characters to and from the instrument

NMEA messages to decode = GGA, GLL, RMA, RMC, TRF, DBT, DPT

Press @ to change the interface box setup

Looking at selected lines:

- *PC baud rate* - Communication between computer and Interface Box, factory set to 9600.
- *SEACAT baud rate* - Communication between Interface Box and CTD, factory set to 4800.
- *7 data bits, even parity* - Communication between computer, Interface Box, and CTD, factory set to 7 data bits and even parity (7 data bits and even parity required for SBE 16, 19, 21, or 25; 8 data bits and no parity required for SBE 16*plus*, 16*plus* V2, 19*plus*, or 19*plus* V2).
- *NMEA baud rate* - Communication between Interface Box and NMEA device, factory set to 4800.
- *Start mode* - Defines default behavior on power-up. *Echo characters to and from the instrument* puts Interface Box in Mode 1 on power-up, allowing system to communicate with the CTD, so the CTD can be set up through the Interface Box. *Add Lat/Lon to the real-time HEX data* puts Interface Box in Mode 2 on power-up, allowing system to start acquiring Hex and NMEA data.
- *NMEA messages to decode* - Output from NMEA device must match one of these messages.

**Notes:**

- **If the communication settings you set in Seaterm's Configure menu do not match the communication settings in the Interface Box (factory default 9600 baud for communication between Box and CTD, 7 data bits, even parity), the display will show *garbage* characters.** If this happens, go to *Changing Communication Settings between Interface Box and Computer* below before proceeding.
- If in the setup menu and no user input is received within 60 seconds, the Interface Box times out and exits the setup menu. Re-enter the setup menu by typing @.

**Note:**

If you previously selected option 4 (you have a NMEA depth device as well as a NMEA position device), the start mode 2 description changes to:  
Start mode = Add Lat/Lon/**Depth**  
to the real-time HEX data

4. Type @ to access the setup menu. The display looks like this:

Interface Box set up menu:

Modes:

1. Echo characters to and from the instrument
2. Add Lat/Lon to the real-time HEX data from the instrument
3. Transmit Lat/Lon only

Options:

4. Add NMEA Depth to the real-time HEX/Lat/Lon data
5. Do not add NMEA Depth to the real-time HEX/Lat/Lon data

Communications:

6. Change communication settings and start mode
7. Display communication settings and start mode

Diagnostics:

8. enable diagnostic level 1
9. enable diagnostic level 2

the current mode = 1. Echo characters to and from the instrument

enter 1, 2, 3, 4, 5, 6, 7, 8, or 9 followed by Enter, or press @ to exit the set up menu

selection =

5. To view the current communication and start mode settings, type 7 and press the Enter key. The display looks like this:

```
PC baud rate = 9600
SEACAT baud rate = 4800
7 data bits, even parity
NMEA baud rate = 4800
Start mode = Echo characters to and from the instrument
```

If the *SEACAT baud rate* does not match the baud rate set in your CTD, the computer will not be able to communicate with the CTD through the Interface Box. Step 6 provides instructions for changing the CTD baud rate in the Interface Box to match your CTD.

6. To change the current communication settings and/or start mode settings, type 6 and press the Enter key. The display looks like this:

```
PC baud rate = X, new value = (enter desired value, press Enter)
SEACAT baud rate = X, new value = (enter desired value, press Enter)
parity = X, new value = even parity or no parity [e/n] (enter e or n, press Enter)
NMEA baud rate = X, new value = (enter desired value, press Enter)
Start mode = X, new value = echo or add Lat/Lon [e/a] (enter e or a, press Enter)
```

The display then shows your new selections. Type @ to return to the setup menu.

7. Type 1 and press the Enter key to put the Interface Box in **mode 1** (*echo characters to and from the instrument*), **which is the mode required for communicating with the CTD (i.e., sending setup commands)**.
8. Type @ to exit the setup menu.
9. Click Connect on the Toolbar (or press the Enter key several times) to establish communication with the CTD (through the Interface Box). The system should respond with an S> prompt.
10. Click Status on the Toolbar to send **DS** and display CTD status. If the status displays and is correct, the system is connected properly.
11. If desired, send setup commands to the CTD.
12. Send **QS** to put the CTD in quiescent (sleep) state.

**Note:**

If you select option 4 (you have a NMEA depth device as well as a NMEA position device), the mode 2 description changes to:

2. Add Lat/Lon/**Depth** to the real-time HEX data from the instrument

**Note:**

The communication and start mode settings were also shown in the status message that appeared when you turned on power to the Interface Box; see Step 3 above.

**Notes:**

- CTD baud rate must be less than or equal to PC baud rate.
- NMEA baud rate is limited to 4800 or 9600.
- Parity selection also affects the data bits used for communication:
  - even parity = 7 data bits,
  - no parity = 8 data bits.
- Changing *PC baud rate* or *parity* will disrupt communications, because they must match the settings in Seaterm's Configure menu. See *Changing Communication Settings between Interface Box and Computer* below for changing these settings and reestablishing communications.

13. **If using the Interface Box with a NMEA device:** Type @ to return to the setup menu. Type 3 and press the Enter key to switch to mode 3. The display looks like this:

```
Interface Box set up menu:
Modes:
1. Echo characters to and from the instrument
2. Add Lat/Lon to the real-time HEX data from the instrument
3. Transmit Lat/Lon only
Options:
4. Add NMEA Depth to the real-time HEX/Lat/Lon data
5. Do not add NMEA Depth to the real-time HEX/Lat/Lon data
Communications:
6. Change communication settings and start mode
7. Display communication settings and start mode
Diagnostics:
8. enable diagnostic level 1
9. enable diagnostic level 2

the current mode = 3. Transmit Lat/Lon only

enter 1, 2, 3, 4, 5, 6, 7, 8, or 9 followed by Enter, or press
@ to exit the set up menu

selection =
```

Go to **Step 14** to verify proper operation if the Interface Box is used with a NMEA navigation (position) device.

Go to **Step 15** to verify proper operation if the Interface Box is used with **both** a NMEA navigation (position) device **and** a NMEA depth device.

**Note:**

NMEA depth data will not appear in Mode 3. If using both a NMEA navigation device and a NMEA depth device, go to Step 15.

14. **If using the Interface Box with a NMEA navigation (position) device:**

Type @ to exit the setup menu. You should begin seeing NMEA data display in Seaterm. Each time NMEA data is received, the yellow *RX NMEA* LED on the Interface Box should flash.

- If NMEA data does not appear, verify that the Interface Box is connected to the NMEA device and that the proper cable is used.
- See *Troubleshooting NMEA Interface* below for additional instructions if needed.

15. **If using the Interface Box with a NMEA navigation (position) device and a NMEA depth device:** While in mode 3, type 8 and press the Enter key to switch to mode 8. Mode 8 is a diagnostic mode that passes all raw NMEA characters received to the screen. The response indicates:

```
the current mode = 3. Transmit Lat/Lon only
diagnostic level 1 enabled.
```

Type @ to exit the menu. You should begin seeing **raw** NMEA messages display in Seaterm. Typical RMC and DPT messages are:

```
$LGRMC,123113.21,A,3625.12,N,12121.34,W,1.2,4.5,231294,1.2,a*45<CR><LF>
$$DDPT,0005.4,0000.0*56<CR><LF>
```

See *Appendix I: NMEA Device Message and Data Formats* for a description of all the NMEA messages the Interface Box can decode.

- If NMEA data does not appear, verify that the Interface Box is connected to the NMEA device and that the proper cable is used.
- See *Troubleshooting NMEA Interface* below for additional instructions if needed.

16. Turn off power to the Interface Box.

**Note:**

To exit diagnostic mode, turn off power to the Interface Box.



## Changing Communication Settings between Interface Box and Computer

Because the Interface Box ships standard only with the SBE 21, Sea-Bird sets the Interface Box with factory defaults (9600 baud, 7 data bits, even parity) for use with the SBE 21; these defaults are also appropriate for the SBE 16, 19, and 25. If the communication settings in Seaterm's Configure menu do not match the settings in the Interface Box, the display shows *garbage* characters when you power up the Interface Box. This happens most often when using the Interface Box for the first time with an SBE *16plus*, *16plus V2*, *19plus*, or *19plus V2*, because they require 8 data bits and no parity.

The procedure below applies to using an SBE *16plus*, *16plus V2*, *19plus*, or *19plus V2* with an Interface Box set at factory defaults. **Note that once you change communication settings in the Interface Box, it will retain the new settings, even if you remove power.**

1. In the Configure menu, select the **SBE 21**, regardless of which CTD you are actually using. This will allow you to establish communications using the Interface Box defaults, so that you can then change the communications settings to match your CTD.
2. In the Configuration Options dialog box, click on the COM Settings tab. Set the baud rate to 9600, data bits to 7, and parity to even.
3. In the Communications menu, select *Send 5 second break*.
4. Wait at least 10 seconds. Turn power to the Interface Box off and then on again. The display in Seaterm should look like this:

**Note:**

*Send 5 second break* resets the communication settings in the Interface Box to factory defaults:

- PC baud rate 9600
- CTD baud rate 4800
- 7 data bits, even parity
- NMEA baud rate 4800

```
Interface box V 3.1b setup:
```

```
PC baud rate = 9600
```

```
SEACAT baud rate = 4800
```

```
7 data bits, even parity
```

```
NMEA baud rate = 4800
```

```
start mode = Echo characters to and from the instrument
```

```
NMEA messages to decode = GGA, GLL, RMA, RMC, TRF, DBT, DPT
```

```
Press @ to change the interface box setup
```

5. Press **@** to change the Interface Box setup. Type **6** and press the Enter key to change the communication settings in the Interface Box to those required for use with your CTD (for *16plus*, *16plus V2*, *19plus*, or *19plus V2*: 8 data bits and no parity; see CTD configuration sheet for CTD baud rate). The display looks like this:

```
PC baud rate = X, new value =
```

```
(enter desired value, press Enter)
```

```
SEACAT baud rate = X, new value =
```

```
(enter desired value, press Enter)
```

```
parity = X, new value = even parity or no parity [e/n]
```

```
(enter e or n, press Enter)
```

```
NMEA baud rate = X, new value =
```

```
(enter desired value, press Enter)
```

```
Start mode = X, new value = echo or add Lat/Lon [e/a]
```

```
(enter e or a, press Enter)
```

The display then shows your new selections. Type **@** to return to the setup menu.

**Note:**

The parity selection also affects the data bits used for communication:

- even parity = 7 data bits
- no parity = 8 data bits

**Note:**

If using SBE *16plus V2*, select SBE *16plus*. If using SBE *19plus V2*, select SBE *19plus*.

6. In the Configure menu, select the actual CTD you are using with the Interface Box. On the COM Settings tab, select settings to match the settings you input to the Interface Box in Step 5. Click *OK* to save the settings and exit the dialog box.
7. Turn power to the Interface Box off and then on again. The display in Seaterm should look like this:

```
Interface box V 3.1b setup:
```

```
PC baud rate = 9600
```

```
SEACAT baud rate = 4800
```

```
8 data bits, no parity
```

```
NMEA baud rate = 4800
```

```
start mode = Echo characters to and from the instrument
```

```
NMEA messages to decode = GGA, GLL, RMA, RMC, TRF, DBT, DPT
```

```
Press @ to change the interface box setup
```

8. Continue testing, starting at Step 8 in *Setting Up and Testing System* above.

## Troubleshooting NMEA Interface

### Problem 1: Yellow RX NMEA LED Not Flashing

**Cause/Solution 1:** Wiring may be incorrect. Check cables and connections between the Interface Box, NMEA device, and computer.

**Cause/Solution 2:** NMEA device may be set to the wrong communication parameters (Interface Box requires 4800 or 9600 baud, 8 data bits, 1 stop bit, and no parity from NMEA device). Reset device's communication parameters.

**Cause/Solution 3:** NMEA device may not be transmitting data. See the device manual for setup details. To verify that it is sending data, connect an oscilloscope with ground on NMEA B (T17) and the probe on NMEA A (T16). The signal should be less than 0.5 volts between messages and have pulses greater than 4 volts for at least 0.2 milliseconds during the message.

**Cause/Solution 4:** Interface Box may not be operating properly. To verify, use the NMEA message simulation program supplied with Seasoft. This program simulates a NMEA device transmitting a NMEA message (see *Appendix II: NMEA Message Simulation Program*).

**Cause/Solution 5:** NMEA device may be transmitting a NMEA message that is not compatible with the Interface Box. To verify, view the raw NMEA messages:

1. In the Interface Box setup menu (see Steps 1 - 4 in *Setting Up and Testing System* above), type 3 and press the Enter key to switch to mode 3.
2. When in mode 3, type 8 and press the Enter key to switch to mode 8. Mode 8 is a diagnostic mode that passes **all** raw NMEA characters received to the screen. The response indicates:

```
the current mode = 3. Transmit Lat/Lon only
diagnostic level 1 enabled.
```

3. Type @ to exit the menu. You should begin seeing **raw** NMEA messages display in Seaterm. A typical RMC NMEA message is:

```
$LGRMC,123113.21,A,3625.12,N,12121.34,W,1.2,4.5,231294,1.2,a*45<CR><LF>
```

See *Appendix I: NMEA Device Message and Data Formats* for a description of all the NMEA messages the Interface Box can decode.

- **If the NMEA messages received in mode 8 do not match any of the messages that the Interface Box can decode**, this NMEA device cannot be used with the Interface Box.
- **If no NMEA messages are received in mode 8**, the problem could be in the Interface Box PCB, cable, or NMEA device. Verify that the Interface Box PCB is operating properly using NMEATest, the simulation program supplied with Seasoft. This program simulates a NMEA device transmitting a NMEA message (see *Appendix II: NMEA Message Simulation Program*).

### Problem 2: Yellow RX NMEA LED Flashing, but Lat/Lon Data Displaying Incorrectly

**Cause/Solution 1:** NMEA device may be transmitting a NMEA message that has an unexpected format. Contact Sea-Bird.

**Note:**

To exit diagnostic mode, turn off power to the Interface Box.

## Setting Up CTD Configuration (.xmlcon or .con) File in Seasave

### Notes:

- Seasave and SBE Data Processing versions 7.20 introduced .xmlcon files (in XML format). Versions 7.20 and later allow you to open a .con or .xmlcon file, and to save it to a .con or .xmlcon file. Seasave and SBE Data Processing use the same file.
- A new or recalibrated CTD ships with a configuration file that reflects the current configuration as we *know it*. The file is named with the instrument serial number, followed by a .con extension. For example, for a CTD with serial number 2375, Sea-Bird names the file *2375.con*. You may rename the file (but not the extension) if desired; this will not affect the results.

Seasave, our real-time data acquisition and display program, requires a configuration file, which defines the CTD – integrated auxiliary sensors, and channels, serial numbers, and calibration dates and coefficients for all the sensors (conductivity, temperature, pressure, as well as auxiliary sensors). Seasave (as well as our data processing software) uses the information in the configuration file to interpret and process the raw data. **If the configuration file does not match the actual instrument configuration, the software will not be able to interpret and process the data correctly.**

**The configuration (.xmlcon or .con) file must indicate if NMEA position and depth data are being added to the CTD data by the Interface Box or by the computer running Seasave.** The configuration file setup overrides the mode selection in the Interface Box (the Interface Box can be set to echo characters to and from the CTD, to add Lat/Lon data to the CTD hex data, or to transmit Lat/Lon data only). In other words, real-time transmission of NMEA data while acquiring data in Seasave is dependent only on the configuration file setting. To verify the contents of the .xmlcon or .con file:

### Notes:

For NMEA depth data (DBT or DPT):

- Depth data can be decoded and merged with CTD data only if NMEA position data (GGA, GLL, RMA, RMC, or TRF) is also available.
- Seasave and SBE Data Processing are compatible with NMEA depth data coming through the Interface Box only for the SBE 19, *19plus*, *19plus V2*, 21, or 25.

1. Double click on Seasave.exe.
2. Click Configure Inputs. On the Instrument Configuration tab, click *Open*. In the dialog box, select the .xmlcon or .con file and click Open.

- The configuration information appears on the Instrument Configuration tab. Verify: sensors match those on your CTD, auxiliary sensors are assigned to the correct channels, calibration coefficients for all sensors are up-to-date, *NMEA position data added* is selected if using a NMEA navigation device, and other NMEA selections match your system setup. Click Modify to bring up a dialog box (example shown below for the SBE 21) to change the configuration and/or to view / modify calibration coefficients.

**Configuration for the SBE 21 Seacat**

Configuration file opened: None

Remote temperature: SBE 38

External voltage channels: 1

Sample interval seconds: 5

NMEA position data added     NMEA depth data added

NMEA device connected to deck unit     NMEA time added

NMEA device connected to PC

Scan time added

Channel	Sensor
1. Frequency	Temperature
2. Frequency	Conductivity
3. Serial RS-232	Temperature, SBE 38
4. A/D voltage 0	pH

Buttons: New, Open..., Save, Save As..., Select..., Modify..., Report..., Help..., Exit, Cancel

**Callout 1 (Top Left):** Channel/Sensor table reflects this choice. Must agree with SBE 21 setup for SVx (x=0, 1, 2, 3, or 4) command; see reply from DS. Voltage channel 0 in .xmlcon or .con file corresponds to sensor wired to channel 0 on end cap connector, voltage channel 1 corresponds to sensor wired to channel 1 on end cap connector, etc.

**Callout 2 (Top Right):** Channel/Sensor table reflects this choice (shows RS-232 channel for SBE 38, or additional frequency-based temperature channel for SBE 3). Must agree with SBE 21 setup (SBE38= or SBE3=) to enable / disable external temperature sensor; see reply from DS. If remote temperature is selected, Seasave and SBE Data Processing use remote temperature data to calculate density and sound velocity.

**Callout 3 (Middle Right):** Time between scans. Used to calculate elapsed time, if you select time as output parameter. Must agree with SBE 21 setup (SI); see reply from DS.

**Callout 4 (Middle Left):** NMEA - Select if NMEA navigation device used, and select whether NMEA device is connected directly to Interface Box (deck unit) or to computer. You can also append NMEA depth data (3 bytes) and NMEA time data (4 bytes) after Lat/Lon data. Seasave adds current latitude, longitude, and universal time code to data header; appends NMEA data to every scan; and writes NMEA data to .nav file every time Ctrl F7 is pressed or Add to .nav File is clicked. Note: NMEA time can only be appended if NMEA device connected to computer.

**Callout 5 (Middle):** Select to have Seasave append time (seconds since January 1, 1970 GMT) to each data scan.

**Callout 6 (Bottom Right):** New to create new .xmlcon or .con file for this CTD. Open to select different .xmlcon or .con file. Save or Save As to save current .xmlcon or .con file settings.

**Callout 7 (Bottom Center):** Shaded sensors cannot be removed or changed to another type of sensor. All others are optional.

**Callout 8 (Bottom Left):** Click a (non-shaded) sensor and click **Select** to pick a different sensor for that channel. A dialog box with a list of sensors appears. Select sensors after number of voltage and frequency channels have been specified above.

**Callout 9 (Bottom Right):** Click a sensor and click **Modify** to change calibration coefficients for that sensor.

- Click *Save* or *Save As* to save any changes to the .xmlcon or .con file. Click *Exit* when done reviewing / modifying the configuration.

# Section 4: Operating System

This section covers:

- Acquiring real-time data with Seasave
- Uploading CTD data from memory

See *Interface Box Connections, Switches, and LEDs* in *Section 2: Description of Interface Box* for wiring details.

## Acquiring Real-Time Data with Seasave

1. Turn on power to the Interface Box.
2. Depending on the CTD and its setup, you may need to send a command to start logging in Seaterm. If so, run Seaterm and send the appropriate command to start logging, then close Seaterm. See the CTD manual for details.
3. Double click on Seasave.exe.
4. Perform any desired setup in the Configure Inputs, Configure Outputs, and Display menus.
5. In the Real-Time Data menu, select *Start*. The dialog box looks like this:

### Note:

The baud rate between the Interface Box and computer (defined in Configure Inputs, on the Serial Ports tab) must agree with the Interface Box setup (1200, 2400, 4800, 9600, or 19200 – factory set to 9600).

### Data Archiving Options:

- **Begin archiving data immediately** to store raw (frequencies, A/D counts, and/or voltages) real-time data as soon as Start button is clicked and communication is established.
- **Begin archiving data when 'Start Archiving' command is sent** to control when data begins to be written to file. If you make this selection, when you click Start button and communication is established, a dialog box with Start Archiving button appears. Click this button when ready to begin saving scans to file, or select Start Archiving in Real-Time Data menu.
- **Do not archive data for this cast** to not save data to a file. Real-time data will still appear in displays.

**Configuration Options:** Currently selected instrument configuration (.xmlcon or .con) file is shown, containing information on number and type of sensors interfacing with CTD, calibration coefficients, and inclusion of NMEA data with output from CTD. To modify input configuration (.xmlcon or .con file, serial ports, TCP/IP ports, and/or miscellaneous), click Configure Inputs. To modify outputs (serial data output, serial ports, shared file output, mark variables, TCP/IP output, TCP/IP ports, SBE 14 remote display, PC alarms, header form, and/or diagnostics), click Configure Outputs.

- **Timeout in seconds at startup:** Time allowed before first data scan is received from CTD. Seasave will *time out* and stop attempting to acquire data if data is not received from CTD within this time period.
- **Timeout in seconds between scans:** Maximum **gap** allowed between scans after first data scan is received from CTD. Seasave will *time out* and stop attempting to acquire data if data is not received from CTD within this time period (for example, if a problem with power to the CTD interrupts data acquisition, Seasave stops attempting to acquire data after this gap).

Appears in dialog box if .xmlcon or .con file indicate that NMEA data is added through deck unit (interface box). If selected, Seasave resets Interface Box to State 1 when acquisition stops. State 1 is Echo only mode (no NMEA data is sent); is useful for setting up CTD.

**Start Real-Time Data Acquisition**

Data Archiving Options

- Begin archiving data immediately
- Begin archiving data when 'Start Archiving' command is sent
- Do not archive data for this cast

Output data [HEX] file

C:\Documents and Settings\vdresko\My Documents\19plustest.hex

Select Output Data File Name

Configuration Options

Instrument configuration [.xmlcon or .con] file: (to change select Configure Inputs)

C:\Documents and Settings\vdresko\My Documents\19plustest.xmlcon

Configure Inputs      Configure Outputs

Timeout in seconds at startup      60

Timeout in seconds between scans      20

Reset deck unit to state 1 when acquisition stops

Report      Help      Start      Exit      Cancel

6. In the Start Real-Time Data Acquisition dialog box, click *Start*.
  - A. If you selected *Begin archiving data immediately* or *Begin archiving data when 'Start Archiving' command is sent* above, and selected *Prompt for Header Information* in the Header Form setup (Configure Outputs), the Header Information dialog box appears. Fill in the desired header and click OK.
  - B. If you selected *NMEA position data added* in the configuration (.xmlcon or .con) file, Seasave initializes NMEA communications. Seasave automatically sends a command(s) to put the Interface Box in Mode 1 (do not transmit NMEA data), Mode 2 (append NMEA position data to SBE 21 data), or Mode 2 with Option 4 (append NMEA position data to CTD data, and also append NMEA depth data), depending on the setup of the configuration file.
  - C. If you selected *Check Scan Length* in the Options menu, Seasave checks the configuration (.xmlcon or .con) file to verify that the scan length defined by the configuration matches the CTD (i.e., number of sensors and inclusion of NMEA is as defined in the configuration file). If a *Scan length error* appears, verify that:
    - You are using the correct .xmlcon or .con file.
    - The .xmlcon or .con file has been updated as necessary if you added or deleted sensors, added or deleted NMEA, etc.
  - D. Seasave sends a message, which varies, depending on the CTD:
    - (For **SBE 21**) *Waiting for data . . .* Seasave will *time out* if data is not received within *Timeout in seconds at startup*.
    - (For **SBE 19plus or 19plus V2**) *Waiting for data . . .* If you have already started logging data, ignore the message; otherwise, slide the switch to the On position or apply external power, as applicable to your setup of the CTD. Seasave *times out* if data is not received within *Timeout in seconds at startup*.
    - (For **SBE 19 or 25**) *Please turn on the . . . using the magnetic switch*. If you have already started logging data, ignore the message; otherwise, slide the switch to the On position. For the SBE 25, data starts appearing in a few seconds; for the SBE 19, there may be a wait of up to 1 minute before data appears. Seasave *times out* if data is not received within *Timeout in seconds at startup*.
  - E. Real-time data then starts appearing in the screen displays.
7. To stop logging and real-time data acquisition:
  - A. For an instrument that was started by movement of a magnetic switch (such as SBE 19, *19plus*, *19plus V2*, or 25), slide the switch to the off position.
  - B. In the Real-Time Data menu, select *Stop*.
  - C. For an instrument that was started by command, close Seasave. Open Seaterm, establish communications with the CTD, and send the appropriate command to stop logging. Then send the command to put the CTD in quiescent (sleep) state.
8. Turn off power to the Interface Box.

**Note:**

The **SBE 19** (not *19plus* or *19plus V2*) and **25** CTD must be in quiescent (sleep) state when the magnetic switch is turned on to start logging data. If not, when the switch is turned on the CTD will **not** log data. A common problem is that communications are established with the CTD using Seaterm, and then Seaterm is exited without putting the CTD into quiescent state with **QS**. When 2 minutes pass without any communication between the computer and CTD, the CTD times out and enters quiescent state automatically. To ensure that Seasave works correctly, verify that the CTD is in quiescent state or is already logging data when Seasave is started.

**Note:**

See the SBE Data Processing manual and/or Help files for details on processing the data.

## Uploading CTD Data from Memory

Typically, data processing is performed on the real-time data acquired in Seasave. However, some users choose to upload the data in the CTD's memory as a back-up to the real-time data. This allows for comparison of the data in memory to the real-time data, to ensure that cable problems, noise, etc. did not corrupt the real-time data.

Upload data from the CTD's memory as follows:

- **SBE 16, 16*plus*, 16*plus* V2, 19, 19*plus*, 19*plus* V2, or 25** - **Connect the CTD directly to the computer**, using the data I/O cable provided with the CTD. Follow directions in the CTD manual for uploading data.
- **SBE 21** - Leave the SBE 21 connected to the Interface Box (the Interface Box provides power for the SBE 21). Follow directions in the SBE 21 manual for uploading data.

# Section 5: Routine Maintenance

To clean the Interface Box:

1. Disconnect the power and any other cables from the Interface Box.
2. Using a soft cotton cloth dampened with warm water, clean the exterior of the Interface Box with gentle pressure. Use special care cleaning around any connectors, to avoid getting water into them.
3. Wait until the Interface Box is completely dry before reconnecting power cables and other electrical connections.



# Glossary

**Note:**

All Sea-Bird software listed was designed to work with a computer running Windows XP service pack 2 or later, Windows Vista, or Windows 7.

**NMEATest** – Sea-Bird’s Windows NMEA message simulation program, which simulates NMEA messages for testing purposes (installed with SBE Data Processing).

**PCB** – Printed Circuit Board.

**SBE Data Processing** – Sea-Bird’s Windows data processing software, which calculates and plots temperature, conductivity, pressure, data from auxiliary sensors, and derived variables such as salinity and sound velocity.

**Scan** – One data sample containing temperature, conductivity, pressure, optional auxiliary inputs.

**Seasave V7** – Sea-Bird’s Windows software used to acquire, convert, and display real-time or archived raw data.

**Seasoft V2**– Sea-Bird’s complete Windows software package, which includes software for communication, real-time data acquisition, and data analysis and display. Seasoft V2 includes **Seaterm**, **SeatermV2**, **Seasave V7**, **SBE Data Processing**.

**Seaterm** – Sea-Bird’s Windows terminal program used to communicate with the Interface Box and/or the CTD.







**SeatermV2** – Windows terminal program *launcher*. Depending on the instrument selected, it launches Seaterm232 (RS-232 instruments), Seaterm485 (RS-485 instruments), or SeatermIM (inductive modem instruments).

**Seaterm232** – Windows terminal program used with Sea-Bird instruments that communicate via an RS-232 interface, and that were developed or redesigned in 2006 and later. The common feature of these instruments is the ability to output status information in XML.

---

## Safety and Electrical Symbols

Some or all of the following symbols may be used on the optional Interface Box:

Symbol	Description
	Potentially hazardous voltage.
	Hazardous! Voltage > 30 VDC may be present.
	Attention! There is a potential hazard; consult the manual before continuing.
	DC (Direct Current).
	Double insulated. The metal enclosure of the Interface Box is isolated such that protection from electrical shock is provided through reinforced electrical insulation.
	Static awareness. Static discharge can damage part(s).

# Appendix I: NMEA Device Message and Data Formats

## Message Formats

### Notes:

- represents two device-specific characters.
- x represents miscellaneous parameters that are ignored by the Interface Box.
- <CR> is carriage return.
- <LF> is line feed.
- See the table below for definitions of all other message parameters.
- Seasave and SBE Data Processing are compatible with NMEA depth data in the data stream. NMEA depth data can be decoded and merged with CTD data only if NMEA position data is also available.
- Seasave supports acquisition of data from a NMEA device connected to the deck unit for all the instruments covered in this manual, or connected directly to the computer for the SBE 19, 19plus, 19plus V2, 21, 25, and 49.

### GGA - Global Positioning System Fix Data

Time, position, and fix-related data for a GPS receiver.

```
$--GGA,hhmmss.ss,llll.ll,a,yyyyy.yy,b,x,xx,x.x,x.x,M,x.x,M,x.x,xxxx*hh<CR><LF>
```

### GLL - Geographic Position - Latitude/Longitude

Latitude and Longitude of present position, time of position fix, and status.

```
$--GLL,llll.ll,a,yyyyy.yy,b,hhmmss.ss,A*hh<CR><LF>
```

### RMA - Recommended Minimum Specific Loran-C Data

Position, course, and speed data provided by a LORAN-C receiver.

```
$--RMA,A,llll.ll,a,yyyyy.yy,b,x,x,x,x,x,x,x,x,x,x,a*hh<CR><LF>
```

### RMC - Recommended Minimum Specific GPS/TRANSIT Data

Time, date, position, course, and speed data provided by a GPS or TRANSIT navigation receiver.

```
$--RMC,hhmmss.ss,A,llll.ll,a,yyyyy.yy,b,x,x,x,x,ddmmyy,x,x,a*hh<CR><LF>
```

### TRF - TRANSIT Fix Data

Time, date, position, and information related to a TRANSIT fix.

```
$--TRF,hhmmss.ss,ddmmyy,llll.ll,a,yyyyy.yy,b,x,x,x,x,x,x,x,x,xxx,A*hh<CR><LF>
```

### DBT - Depth Below Transducer

Depth in fathoms, meters, and feet

```
$--DBT,xxxx.x,f,ddd.d,M,xxxx.x,F*hh<CR><LF>
```

### DPT - Depth

Depth

```
$--DPT,ddd.d,xxxx.x,xxxx.x*hh<CR><LF>
```

Field Type	Symbol	Definition
Status	A	Single character field: A = Yes, data valid, warning flag clear V = No, data invalid, warning flag set
Latitude	llll.ll	Fixed/Variable length field: degrees minutes.decimal - 2 fixed digits of degrees, 2 fixed digits of minutes, and variable number of digits for decimal-fraction of minutes. Leading zeros always included for degrees and minutes to maintain fixed length. Decimal point and associated decimal-fraction are optional if full resolution not required.
	a	N or S
Longitude	yyyyy.yy	Fixed/Variable length field: degrees minutes.decimal - 3 fixed digits of degrees, 2 fixed digits of minutes, and variable number of digits for decimal-fraction of minutes. Leading zeros always included for degrees and minutes to maintain fixed length. Decimal point and associated decimal - fraction optional if full resolution not required.
	b	E or W
Time	hhmmss.ss	Fixed/variable length field: hours minutes seconds.decimal - 2 fixed digits of hours, 2 fixed digits of seconds, and variable number of digits for decimal-fraction of seconds. Leading zeros always included for hours, minutes, and seconds to maintain fixed length. Decimal point and associated decimal-fraction optional if full resolution not required.
Depth	ddd.d (see note at right)	Depth below transducer in meters. Note: Format can be dddd.d or ddd.d
Checksum	*	Optional Checksum Delimiter.
	hh	Optional Checksum Field: Absolute value calculated by exclusive OR'ing 8 data bits (no start or stop bits) of each character in message, between, but excluding \$ and *.

## Data Formats

### Position Data

Seven bytes of position data are appended to each scan of hex data from the CTD.

Our data processing software calculates latitude and longitude as follows:

$$\text{Latitude (deg)} = (\text{byte 1} * 65536 + \text{byte 2} * 256 + \text{byte 3}) / 50000$$

$$\text{Longitude (deg)} = (\text{byte 4} * 65536 + \text{byte 5} * 256 + \text{byte 6}) / 50000$$

Notes:

1. If bit 1 in byte 7 is 1, this is a new position.
2. If bit 8 in byte 7 is 1, Latitude is negative.
3. If bit 7 in byte 7 is 1, Longitude is negative.
4. North latitudes are positive, south latitudes are negative.
5. East longitudes are positive, west longitudes are negative.

#### *Example:*

Appended position data = 2455FC5D32B141

byte 1 = 24 hex = 36 decimal

byte 2 = 55 hex = 85 decimal

byte 3 = FC hex = 252 decimal

byte 4 = 5D hex = 93 decimal

byte 5 = 32 hex = 50 decimal

byte 6 = B1 hex = 177 decimal

byte 7 = 41 hex = 01000001 binary

Latitude =  $(36 * 65536 + 85 * 256 + 252) / 50000 = 47.62616$  degrees

Longitude =  $(93 * 65536 + 50 * 256 + 177) / 50000 = -122.1565$  degrees

Latitude is positive (bit 8 in byte 7 is 0).

Longitude is negative (bit 7 in byte 7 is 1).

This is a new position (bit 1 in byte 7 is 1).

### Depth Data (if applicable)

Three bytes of depth data are appended to each scan of data, after the position data.

Our data processing software calculates depth as follows:

$$\text{Depth (meters)} = (\text{byte 1} * 65536 + \text{byte 2} * 256 + \text{byte 3}) / 10$$

#### *Example:*

Appended depth data = 0032FC

byte 1 = 00 hex = 0 decimal

byte 2 = 32 hex = 50 decimal

byte 3 = FC hex = 252 decimal

Depth =  $(0 * 65536 + 50 * 256 + 252) / 10 = 1305.2$  meters

# Appendix II: NMEA Message Simulation Program

Sea-Bird provides a NMEA message simulation program, NMEATest, as a troubleshooting aid. NMEATest, part of the Seasoft V2 package, simulates a NMEA device transmitting NMEA messages. If the system does not work with the actual NMEA device, but works with NMEATest, the problem is with the interface cable from the NMEA device to the Interface Box or in the NMEA device itself.

**Note:**

While NMEATest can *generate* messages in only the four formats shown, it can *run* using an existing raw NMEA data file in these formats as well as TRF, DBT, and DPT.

**Note:**

**You can also run the simulation using only one computer**, if the computer has a spare COM port.

**Note:**

The Interface Box must be connected to the CTD to test the NMEA interface. If it is not connected, noise on the open *SeaCAT Data I/O* connector will interfere with communication with the Interface Box.

NMEATest is just a simulation, and does not provide an actual data stream from an actual NMEA device. The data transmission baud rate (4800 or 9600) and time between messages are user-programmable. The NMEA message format (RMA, RMC, GLL, or GGA) generated by the program is also user-programmable. Alternatively, the user can specify an existing raw NMEA data file to use for the simulation; see *Appendix I: NMEA Device Message and Data Formats* for the required raw data format.

To execute the simulation program, a **second computer** (computer 2) is needed to emulate the NMEA device. A laptop computer is adequate for this purpose. Install NMEATest on computer 2 (NMEATest is part of the SBE Data Processing installation).

Use the NMEA interface test cable (PN 801424 - supplied with the Interface Box) to connect *NMEA Input* on the Interface Box to the simulation computer. The simulation test cable connections are:

MS3106A14S-5P	RS-232	Function
Pin B	Pin 3	NMEA A (signal)
Pin C	Pin 5	NMEA B (signal return)

Proceed as follows (instructions are written assuming you are using a second computer to emulate the NMEA device):

1. On computer 1, set up Seaterm to communicate with the Interface Box at the baud, data bits, and parity to match the Interface Box set up (Steps 1 and 2 in *Setting Up and Testing System* in *Section 3: Setting Up System*).
2. Turn on power to the Interface Box. The Interface Box status message displays in Seaterm:

```
Interface box V 3.1b setup:
PC baud rate = 9600
SEACAT baud rate = 4800
7 data bits, even parity
NMEA baud rate = 4800
start mode = Echo characters to and from the instrument
NMEA messages to decode = GGA, GLL, RMA, RMC, TRF, DBT, DPT
Press @ to change the interface box setup
```

3. Type @ to access the setup menu.
4. Type 3 and press the Enter key to switch to mode 3.

5. When in mode 3:
  - A. Type 8 and press the Enter key to switch to mode 8. Mode 8 transmits all NMEA messages in raw form. The menu response indicates that the Interface Box has *diagnostic level 1 enabled*.
  - B. Type 9 and press the Enter key to switch to mode 9. Mode 9 transmits NMEA messages in decoded form. The menu response indicates that the Interface Box has *diagnostic level 1 enabled* and *diagnostic level 2 enabled*, so NMEA messages will be transmitted in raw form followed by decoded form.
6. On computer 2, double click on **nmeatest.exe** (in same directory as SBE Data Processing). The NMEATest screen appears.
7. On the NMEATest screen, click on the Configure menu. The Configure dialog box appears. Select:
  - NMEA message to be simulated (RMA, RMC, GLL, or GGA) **or** select an existing NMEA data file on your computer by clicking *Send File* and browsing to the desired file. If selecting a NMEA data file, the NMEA message must be compatible with the Interface Box (GGA, GLL, RMA, RMC, TRF, DBT, or DPT).
  - Baud rate for transmission of simulated NMEA data to Interface Box (4800 or 9600) – **must match setup of Interface Box**.
  - COMM port on computer 2 for transmission of NMEA data to Interface Box.
  - Message interval (time between simulated messages to be transmitted to Interface Box).Click OK.
8. On the NMEATest screen, click Start. NMEA data should begin to display on the NMEATest screen on computer 2 and in Seaterm on computer 1. The yellow *RX NMEA* LED should flash each time the simulation program transmits a new position.

The data displayed by Seaterm should correspond to that of the simulation program (see *Appendix I: NMEA Device Message and Data Formats* for the raw and decoded NMEA message formats). If properly decoded data appears on the screen, the Interface Box is working properly. If the system works with the simulation program but does not work when connected to the actual NMEA device, the problem is with the cable from the NMEA device to the Interface Box, or in the NMEA device itself.

- Verify that the cable pinouts are correct, especially at the NMEA device. See *Interface Box Connections, Switches, and LEDs* in *Section 2: Description of Interface Box* and also refer to the NMEA device documentation.
- If the cable is correct, verify that the NMEA device is on and is configured to send data. Many NMEA devices have programmable NMEA outputs and may need to be configured before they will transmit NMEA messages. Again, refer to the NMEA device documentation, or contact the device's manufacturer for customer support.

# Appendix III: Replacement Parts

Part Number	Part	Application Description	Quantity
171887	9-pin DB-9P to 9-pin DB-9S cable, 3.0 m (10 ft)	From <i>RS-232C</i> on Interface Box to computer	1
171888	25-pin DB-25S to 9-pin DB-9P cable adapter	For use with computer with DB-25 connector	1
80437 or 80438	4-pin MS3106A-14S-2P to 4-pin RMG-4FS I/O cable: 80437 – 2.5 m (8 ft) 80438 – 10 m (33 ft)	From <i>SeaCAT Data I/O</i> on Interface Box to CTD	1
801424	5-pin MS3106A-14S-5P to 9-pin DB-9S NMEA interface test cable, 1.8 m (6 ft)	From <i>NMEA Input</i> on Interface Box to computer running NMEA simulation program for test purposes	1
17015	Interface Box AC power cable	From Interface Box to AC power source	1
17315	MS-3106A12S-3S	For DC power supply to Interface Box	1
17316	MS-3057-4A clamp	Assembled to 17315	1
17317	MS-3420-4 boot	Assembled to 17315	1
17412	MS-3106A14S-2P	4-pin <i>SeaCAT Data I/O</i> connector	1
17413	Clamp	Assembled to 17412	1
17414	Boot	Assembled to 17412	1
17671	MS-3106A-14S-5P	5-pin <i>NMEA Input</i> connector	1
17413	Clamp	Assembled to 17671	1
17414	Boot	Assembled to 17671	1

# Appendix V: Manual Revision History

Manual Version	Date	Description
000	--	<ul style="list-style-type: none"> <li>Initial release.</li> </ul>
001	--	<ul style="list-style-type: none"> <li>Firmware version 2.0.</li> </ul>
002	--	<ul style="list-style-type: none"> <li>Firmware version 2.0c.</li> </ul>
003	--	<ul style="list-style-type: none"> <li>Add DC NMEA documentation, test simulation programs, general corrections.</li> </ul>
004	--	<ul style="list-style-type: none"> <li>Firmware version 2.0d: Add dip switch position 4 to enable auto time out.</li> </ul>
005	--	<ul style="list-style-type: none"> <li>Firmware version 2.3: change dip switch position 4 to switch between parity 7, even and 8, none.</li> </ul>
006	02/02	<ul style="list-style-type: none"> <li>Firmware version 2.3, major rewrite, add graphics and information on Windows software, general corrections.</li> </ul>
007	11/02	<ul style="list-style-type: none"> <li>Update description and use of NMEA simulation software to Windows version (NMEATest).</li> </ul>
008	08/03	<ul style="list-style-type: none"> <li>NMEA simulator program – correct wiring for test cable.</li> <li>Update cables to 9-pin computer connection.</li> <li>Update .con file screen capture to current version.</li> <li>Change name to SeaCAT/Sealogger RS-232 and Navigation Interface Box.</li> <li>Add baud rate restrictions – All instruments recommend 4800, and default in Seaterm was changed (version 1.40) for 21 to match.</li> <li>Include photos of both sides of box.</li> <li>Add pinout info on connection of box to CTD.</li> </ul>
009	10/03	<ul style="list-style-type: none"> <li>AC version of Interface Box redesigned to eliminate dip switches and allow setup via a menu. AC version of Interface Box has new part number: 90488. Note: DC version was not redesigned.</li> </ul>
010	10/05	<ul style="list-style-type: none"> <li>Update to reflect compatibility with NMEA <b>depth</b> data input to Interface Box when used with SBE 21.</li> <li>Section 2 Specifications: add information on output power to CTD (+12 VDC up to 1.5 amps; this is separate from 2 amps to NMEA device). Note that +12 V and ground on both the SeaCAT and NMEA connectors are isolated from each other.</li> <li>Move wiring information from Section 3 to Section 2.</li> <li>Update PN for cable from Interface Box to computer.</li> </ul>
011	03/07	<ul style="list-style-type: none"> <li>DC powered version (90204) replaced by 90545, which functions the same as the 90488 AC Box. Update 90488 manual to include 90545.</li> <li>Incorporate Seasave V7.</li> </ul>
012	05/08	<ul style="list-style-type: none"> <li>Correct RS-232 pinouts (interface box to computer) – pins 2 and 3 were switched.</li> <li>Include references to 16plus V2 and 19plus V2.</li> <li>Show updated Real-time data acquisition dialog box in Seasave V7 (has new selection regarding resetting the state of the box when the cast is complete).</li> </ul>
013	01/09	<ul style="list-style-type: none"> <li>Update .con file screen capture for Seasave/SBE Data Processing 7.18.</li> <li>Add note where schematic shows NMEA going to deck unit, explain that can go directly to PC.</li> <li>Add information about software compatibility with Vista.</li> <li>Add information to turn off CTD magnetic switch before stopping data acquisition, so putting box back into state 1 is successful.</li> <li>Delete references to SCPlusV2 terminal program, replaced with SeatermV2.</li> </ul>
014	03/09	<ul style="list-style-type: none"> <li>Firmware 3.1a: Add option for starting up in mode 2 instead of mode 1.</li> <li>Add note that Interface Box must be in Mode 1 (characters to/from CTD passing through) if trying to send commands to CTD through Interface Box.</li> </ul>
015	12/09	<ul style="list-style-type: none"> <li>Firmware Version 3.1b: Add ability to set PC baud to 38400 &amp; CTD baud to 19200 &amp; 38400.</li> <li>Housing redesign to meet CE requirements.</li> <li>Manual changes required for CE certification.</li> <li>Add pinout for DC power.</li> <li>Seasave &amp; SBE Data Processing 7.19: allow acquisition of NMEA depth data for profiling CTDs.</li> <li>Seasave &amp; SBE Data Processing 7.20a: Add information about .xmlcon file.</li> <li>Change Seasoft-Win32 to Seasoft V2, update .exe file name to SeasoftV2_date.exe.</li> <li>Update SBE address.</li> </ul>

*Continued on next page*

*Continued from previous page*

016	09/13	<ul style="list-style-type: none"><li>• Add Declaration of Conformity.</li><li>• Add cable wiring drawings.</li><li>• Update software compatibility information.</li><li>• Remove references to Seasave-Win32 (old software) and to old versions of Seasave V7.</li></ul>
-----	-------	---



# Index

---

.con file · 19  
.xmlcon file · 19

---

## **B**

Baud rate · 9, 21

---

## **C**

Cables · 11  
CE certification · 3  
Cleaning · 24  
Communications · 9  
Configuration file · 19  
Connectors · 10  
CTD  
    configuration file · 19  
    upload · 23  
CTD setup · 13

---

## **D**

Data acquisition · 21  
Data bits · 9  
Data formats · 27  
Data upload · 23  
Declaration of Conformity · 3  
Description · 7

---

## **E**

Electrical symbols · 25

---

## **F**

Fan · 10

---

## **G**

Glossary · 25

---

## **I**

Installation · 10

---

## **L**

LEDs · 10

---

## **M**

Maintenance · 24  
Manual revision history · 31  
Message formats · 26

---

## **N**

NMEA

data formats · 27  
message formats · 26  
operation · 12  
simulation program · 28  
troubleshooting · 18  
NMEA · 13  
NMEATest · 7, 13, 28

---

## **O**

Operating modes · 12  
Operating system · 21

---

## **P**

Parity · 9  
Parts  
    replacement · 30

---

## **R**

Real-time acquisition · 21  
Replacement parts · 30  
Revision history · 31  
Routine maintenance · 24

---

## **S**

Safety symbols · 25  
SBE Data Processing · 7, 13  
Seasave · 7, 13, 21  
Seasoft · 7, 13  
Seaterm · 7, 13  
SeatermV2 · 7, 13  
Setup · 13  
Software · 7, 13  
    installation · 13  
Specifications · 8  
System  
    communications · 9  
    description · 7  
    operation · 21  
    wiring · 10

---

## **T**

Testing · 13  
Troubleshooting · 18

---

## **U**

Unpacking · 6  
Uploading data · 23

---

## **V**

Versions · 31

---

## **W**

Wiring · 10, 11