



SEA-BIRD ELECTRONICS, INC.

1808 136th Place N.E., Bellevue, Washington 98005 USA

Telephone: (425) 643-9866 Telex: 292915 SBEI UR

Fax: (425) 643-9954

email: seabird@seabird.com

SBE P/N 50244

DATE	REV	REVISION RECORD	AUTH	DR	CHK
10.03		CHANGE ON DRAWING ONLY	CB	KLP	
3.9.04	A	CHANGED PN 30452 FOR 31263	CB	KLP	

SBE 38 External Temp Mount Kit, 1" Inline Plumbing

KIT CONTENTS

SBE P/N	Manufacturer P/N	Primary SBE Application	QTY
231580	SBE 38 Temp Plenum	Provides water flow to temp probe	1
231581	SBE 38 Temp Plenum Retainer	Secures Temp Sensor To Plenum	1
231582	SBE 38 Remote Temp Plug	Seals Plenum Retainer opening when not in use	1
30254	Washer, 1/4" Split Ring Lock	Use with Plenum Hardware (30451)	2
30570	Washer, 1/4" Flat SS	Use with Plenum Hardware (30451)	2
30809	Morrison seal, .047" hole, Nit	Fits in between Plenum and Plenum Retainer	1
31001	Bolt, 1/4-20 x 1-3/8 HEX SS	Secure Plenum Retainer to Plenum	2
31263	Pipe, 1" Threaded, SS	Interface Plenum to plumbing system	2

A. ASSEMBLING THE PLENUM

1. Lubricate the Morrison seal with a Silicone-based lubricant. *Never use a Petroleum-based lubricant on SBE o-rings and seals.*
2. Clean the Morrison seal surface on the Stainless Steel Plenum (231580) and install the Morrison seal with hole facing out of plenum.
3. Place the Plenum Retainer (231581) so that small hole rests on top of the Morrison Seal.
4. Secure the Retainer to the Plenum with two bolts (31001) and washers (30254, 30570). *The lock washer should rest between the bolt head and the flat washer.*
5. Wrap plumber's tape around the threads of the pipes and install into the plenum as needed to make the assembly fit your present plumbing configurations.

B. INSTALLING THE SENSOR

1. Remove the Temperature Probe Guard from SBE 38 sensor.
2. Insert the temperature probe **carefully** into Plenum Retainer and screw it in until flush.
3. When the sensor is not in use, replace with the remote temperature plug (231582). *Be sure to re-install the probe guard onto the SBE 38 before storing or putting it to other uses.*

SBE DRAWING: 67071

TITLE: SBE 38 Ext Temp Mount Kit Assembly

REV: .01

Sea-Bird Electronics Procedure

PROCEDURE NUMBER: 67071

TITLE: **SBE 38 Ext Temp Mount Kit Assembly**

REVISION: A

EFFECTIVE DATE: 03/10/2004

CHECKED BY: _____ PAGE 1 of 1

ITEM NO.	PART NO.	DRAWING NO.	DESCRIPTION	QTY.
1	231580	21641	SBE38 Temperature Plenum	1
2	231581	21642	SBE38 Temperature Plenum Retainer	1
3	231582	21643	SBE38 Remote Temperature Plug	1
4	30254	N/A	Washer, 1/4 Split Ring Lock, SS	2
5	30570	N/A	Washer, 1/4" Flat, 960C416, SS	2
6	30809	21018D	Morrison Seal .047 ID x .41 OD Nitrile	1
7	31001	N/A	Bolt, 1/4-20 x 1 3/8 Hex Hd, SS	2
8	31263	N/A	Pipe, 1" NPT x 12", Nipple M-M, 304 SS, SCH40	2

DATE	REVISION	DESCRIPTION	AUTH	DR	CHK
10/10/08	.01	Converted to Solidworks	CB	PC	CB

D

D

C

C

B

B

A

A

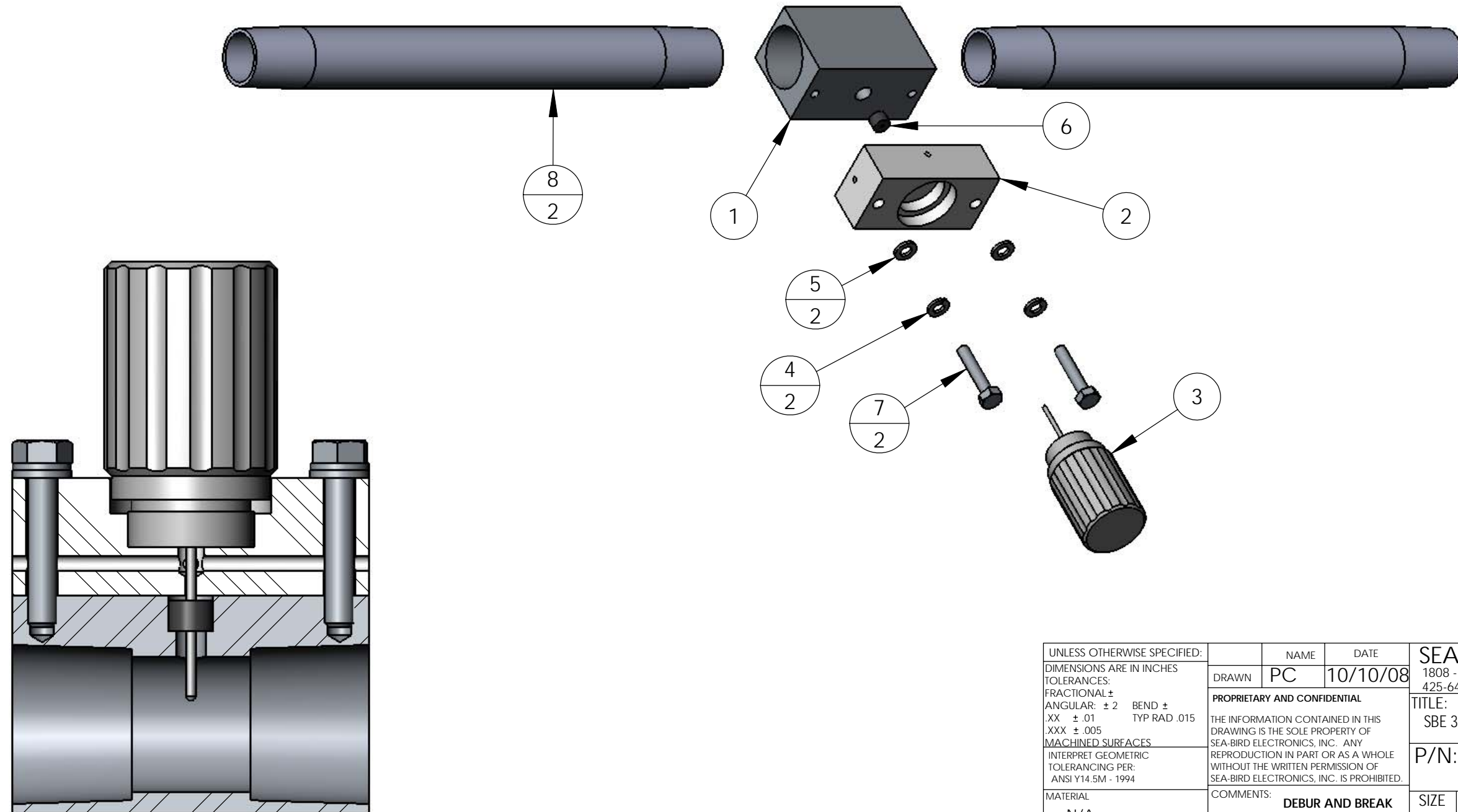

UNLESS OTHERWISE SPECIFIED:		NAME	DATE	SEA-BIRD ELECTRONICS, INC.	
DIMENSIONS ARE IN INCHES		DRAWN	10/10/08	1808 - 136th PLACE NE, BELLEVUE, WA 98005	
TOLERANCES:		PC		425-643-9866	
FRACTIONAL ±		PROPRIETARY AND CONFIDENTIAL		TITLE:	
ANGULAR: ± 2 BEND ±		THE INFORMATION CONTAINED IN THIS DRAWING IS THE SOLE PROPERTY OF SEA-BIRD ELECTRONICS, INC. ANY REPRODUCTION IN PART OR AS A WHOLE WITHOUT THE WRITTEN PERMISSION OF SEA-BIRD ELECTRONICS, INC. IS PROHIBITED.		SBE 38 External Temp Plenum Mount Assembly	
.XX ± .01 TYP RAD .015		COMMENTS:		P/N: 50244	
.XXX ± .005		DEBUR AND BREAK SHARP EDGES		SIZE DWG. NO. REV	
MACHINED SURFACES		Old Part/Draw Info		B 67071 .01	
INTERPRET GEOMETRIC TOLERANCING PER: ANSI Y14.5M - 1994		N/A /N/A		SCALE: 2:5 SHEET 1 OF 1	
MATERIAL N/A		DO NOT SCALE DRAWING			
FINISH N/A					

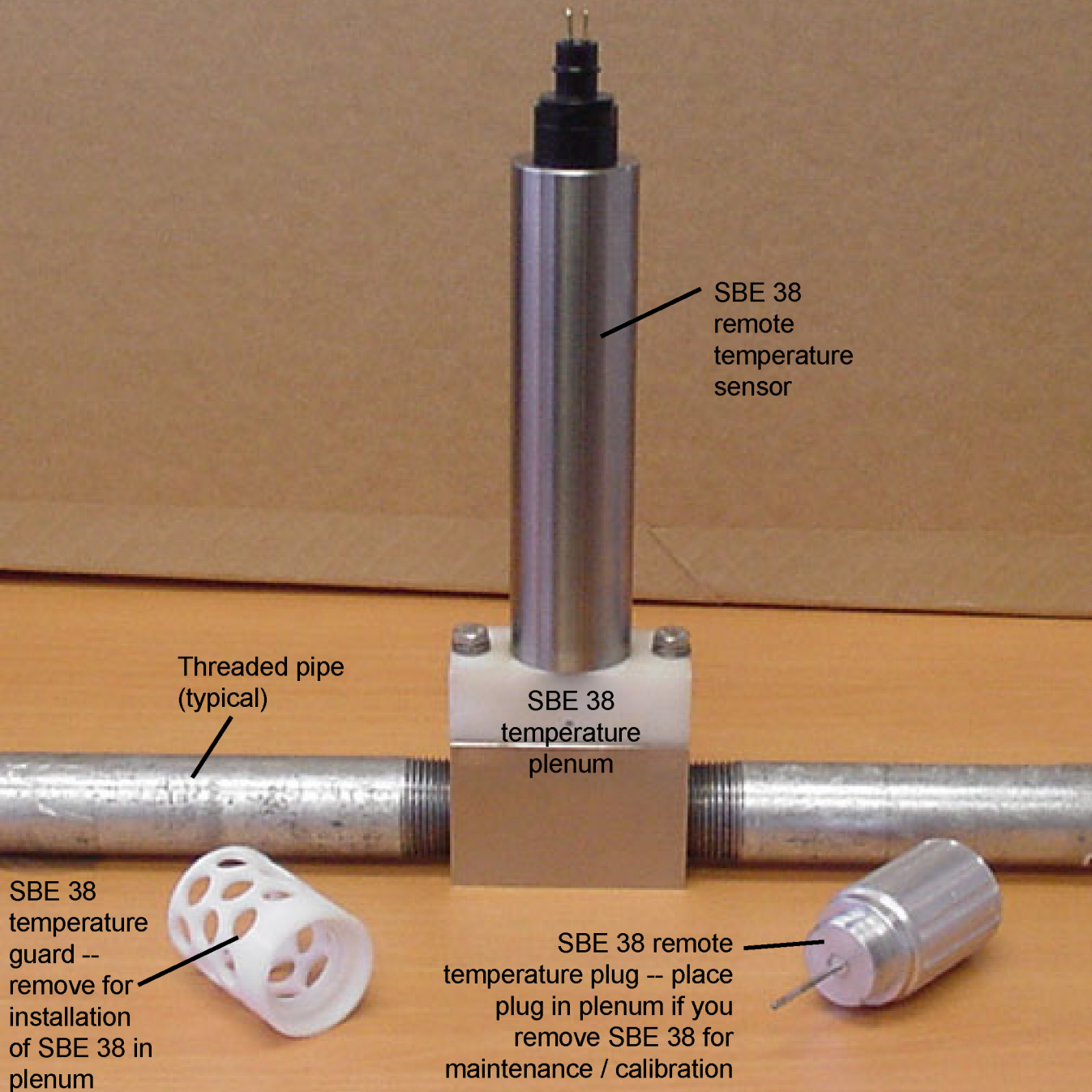

SBE 38
remote
temperature
sensor

Threaded pipe
(typical)

SBE 38
temperature
plenum

SBE 38
temperature
guard --
remove for
installation
of SBE 38 in
plenum

SBE 38 remote
temperature plug -- place
plug in plenum if you
remove SBE 38 for
maintenance / calibration