



SEA - BIRD ELECTRONICS, INC.

13431 NE 20th Street, Bellevue, Washington 98005 USA
 Telephone: (425) 643-9866 Telex: 292915 SBEI UR
 Fax: (425) 643-9954 Email: seabird@seabird.com

SBE P/N 50299/50428/50496

DATE	REV	REVISION RECORD	AUTH	DR	CHK
7.11.05	A	Updated assembly info	KLP		
6.22.07	B	Added P/N 50428 info	CB	PC	
7.5.11	C	Added P/N 50496 info	CB	PC	

SBE 32 Spare Latch Kit

SBE P/N	Manufacturer P/N	Drawing
50299	SBE32 Spare Titanium Trigger Assy H900	76064.06
50428	SBE32 Spare 36 Place Ti Trigger Assy	76064.06
50496	SBE32/SBE55 Trigger Assy, Inj, H900	76064.06

SHARED LATCH PARTS (Part numbers and quantities are the same for all versions)

SBE P/N	Manufacturer P/N	Primary SBE Application	Drawing	Qty
23654	Trigger Pivot Bushing	Placed in small open area of trigger slider	20695	1
23871C	Trigger Cover Plate, Ti	Coated trigger cover plate secured to side plate	20687	1
23872C	Trigger Hook, Ti	Coated trigger placed on side plate pivot shaft to move freely	20688	1
23873C	Trigger Slider, Ti	Placed on large pin of trigger side plate	20689	1
23877	Trigger Spacer, Ti	Spacers between cover and side plates, aligned with screw holes	20696	2
23878	Trigger Pivot Shaft, Ti	Inserts into trigger side plate pivot area	20742	1
232023	SBE32 Actuator Disc, 17-4, SS	Attached to trigger lever for magnetic triggering	20649	1
232094	Trigger Lever, 15-20% Glass Acetal	Placed on pins of side plate and slider to move freely	22239	1

50299 LATCH PARTS (Part numbers and quantities ONLY used on PN 50299)

SBE P/N	Manufacturer P/N	Primary SBE Application	Drawing	Qty
23870C	Trigger Side Plate, Ti	Coated trigger side plate with protruding pins	20686	1
23875	Trigger Support Bar 1, Ti	Attached to side of trigger assembly (indentation faces outside of assembly)	20691	1
23876	Trigger Support Bar 2, Ti	Attached to side of trigger assembly (indentation faces outside of assembly)	20692	1

50428 LATCH PARTS (Part numbers and quantities ONLY used on PN 50428)

SBE P/N	Manufacturer P/N	Primary SBE Application	Drawing	Qty
23944	Trigger Side Plate, Ti	Coated trigger side plate with protruding pins	20932	1
23875	Trigger Support Bar 1, Ti	Attached to side of trigger assembly (indentation faces outside of assembly)	20691	1
23876	Trigger Support Bar 2, Ti	Attached to side of trigger assembly (indentation faces outside of assembly)	20692	1

50496 LATCH PARTS (Part numbers and quantities ONLY used on PN 50496)

SBE P/N	Manufacturer P/N	Primary SBE Application	Drawing	Qty
23870C	Trigger Side Plate, Ti	Coated trigger side plate with protruding pins	20686	1
234141	SBE 32 Trig Sprt Bar 2, Molded Part	Attached to side of trigger assembly (indentation faces outside of assembly)	234141	1
234142	SBE 32 Trig Sprt Bar 1, Molded Part	Attached to side of trigger assembly (indentation faces outside of assembly)	234142	1

SBE DRAWING:
76064.06 SBE 32 Titanium Latch Assembly

Sea-Bird Electronics Procedure
 PROCEDURE NUMBER: **67157**
 TITLE: **SBE Spare Ti Latch Kit Assembly**
 REVISION: **C**
 EFFECTIVE DATE: **07/05/2011**
 CHECKED BY: PC PAGE 1 of 2



SEA - BIRD ELECTRONICS, INC.

13431 NE 20th Street, Bellevue, Washington 98005 USA
Telephone: (425) 643-9866 Telex: 292915 SBEI UR
Fax: (425) 643-9954 Email: seabird@seabird.com

HARDWARE

SBE P/N	Part Description	Primary SBE Application	QTY
30115	Mach Screw, 2-56 x 1/4 FH, SS	Secure actuator disk to trigger lever	2
30657	Mach Screw, 2-56 x 3/8 FH, Slot, Ti	Secure cover plate and slider to side plate	1
30659	Mach Screw, 4-40 x 13/16 FH, Slot, Ti	Attach support bars to trigger assembly	2
30663	Latch Spring, .012"	Placed in large open area of slider against pin to provide recoil motion	1

O-RINGS

SBE P/N	Manufacturer P/N	Primary SBE Application	QTY
30618	O-Ring, Parker, 2-106 E962-90	Placed on trigger spacer for cover plate cushion	2

Latch Assembly

A. Assemble and Install Latch Center Mechanism

1. Set the trigger side plate (23870C or 23944) on the table, such that the round corner faces bottom right.
2. Slip the trigger pivot support shaft (23878) into the hole in the rounded end.
3. Set the trigger hook (23872C) onto the pivot support shaft
 - a. The notched hook should open up and to the left.
 - See drawing 76064
4. Set the trigger slider (23873C) over the pin in the center of the trigger side plate.
 - a. The cut out notch should be on the top, facing left.
 - b. The larger slot over the large pin and the smaller slot over the threaded hole above it.
5. Insert a pivot bushing (23654) in the smaller slot of the trigger slider.
6. Compress the latch spring (30663) and insert it into the large slot on the trigger slider between the pin and the top of the slot.
7. Install the trigger lever (232094) over the pin on the trigger slider and the lower left pin on the side plate.
 - See drawing 76064 for orientation
8. Install the trigger cover plate (23871C) over the entire part.
 - a. The bottom shape of the part needs to match up to the bottom shape of the Trigger side plate.
 - b. The beveled side of the cover plate should face outward from the latch.
9. Fit one 2-56 x 1/4" screw (30657) into the hole toward the top for the cover plate, fit it thru the pivot bushing in the trigger slide and into the threaded hole in the side plate.
 - a. Tighten only enough to engage the threads in the side plate and hold the assembly together.

SBE DRAWING:

76064.06 SBE 32 Titanium Latch Assembly

Sea-Bird Electronics Procedure

PROCEDURE NUMBER: **67157**

TITLE: **SBE Spare Ti Latch Kit Assembly**

REVISION: **C**

EFFECTIVE DATE: **07/05/2011**

CHECKED BY: _____ PC _____ PAGE 2 of 2



SEA-BIRD ELECTRONICS, INC.

13431 NE 20th Street, Bellevue, Washington 98005 USA
Telephone: (425) 643-9866 Telex: 292915 SBEI UR
Fax: (425) 643-9954 Email: seabird@seabird.com

Latch Assembly (continued)

B. Assemble and Install latch rails

1. Fit 2 o-rings (30618) over 1 trigger spacer (23877) so they are snug and somewhat centered.
2. Push the assembly into the space between the trigger and the side plate closest to the rounded end.
 - a. Line up with the holes in the cover and side plates.
3. Apply Loctite 222 to the tips of 2 screws (30659) and wipe them off with a Kim wipe.
4. Set the trigger support bar 1 (23875) over the top of latch so the large end tapers to the top of the latch.
5. Install the first screw through right hole, and through the plates and the o-ring/spacer assembly.
6. Secure screw into support bar 2 (23876). *Support bar 2 should line up parallel with bar 1.*
7. Push a bare trigger spacer (23877) onto the peg under the trigger lever.
 - a. Line up with the holes in the cover and side plates.
8. Install the second screw, the same way as the first.

C. Tighten and test latch

1. The 2 screws through the support bars should be tightened down hard.
2. The smaller top screw is much more crucial.
 - a. Tighten the screw nearly hand tight and test latch.
 - b. Latch should open freely under gravity.
 - c. If the screw is too tight, it will cause friction against the latch.
 - d. We need to tighten this screw as much as possible without causing any friction.
 - *Refer to document 76128 for torque specifications*
3. When latch is properly tightened and works well, set it in a box until all latches are complete.

D. Install Actuator disk

1. Lay a bead of DC-4 over entire lever.
2. Install actuator disk onto lever with countersinks facing out.
3. Secure with 2 screws (30115).

SBE DRAWING:
76064.06 SBE 32 Titanium Latch Assembly

Sea-Bird Electronics Procedure
PROCEDURE NUMBER: **67157**
TITLE: **SBE Spare Ti Latch Kit Assembly**
REVISION: **C**
EFFECTIVE DATE: **07/05/2011**
CHECKED BY: _____ PC _____ PAGE 3 of 2

ITEM NO.	PART NUMBER	DRAWING NUMBER	DESCRIPTION	50299	50428	50496
1	232023	20649E	SBE32 Actuator Disc, 17-4 PH SS H900	1	1	1
2	233816	233816	SBE32 Trig. Lever Wht PBT w/ UV Inhibitor	1	1	1
3	234141	234141	SBE 32 Trig Sprt Bar 2, Molded Part	-	-	1
3	23876	20692D	SBE 32 Trig Sprt Bar 2, Titan	1	1	-
4	234142	234142	SBE 32 Trig Sprt Bar 1, Molded Part	-	-	1
4	23875	20691D	SBE 32 Trig Sprt Bar 1, Titan	1	1	-
5	23654	20695C	SBE 32 Trigger Pivot Bushing	1	1	1
6	23870C	20686E/ 21692A	Coated SBE32 Trig Side Plate, Ti	1	-	1
6	23944	20686E	SBE32 Trigger Side Plate, Titanium	-	1	-
7	23871C	20687D/ 21693A	Coated SBE32 Trig Cvr Plate, Ti	1	1	1
8	23872C	20688C/ 21776A	Coated SBE 32 Trigger Hook, Ti	1	1	1
9	23873C	20689B/ 21777A	Coated SBE32 Trig Slider, Ti	1	1	1
10	23877	20696B	SBE32 Trigger Spacer, Titanium	2	2	2
11	23878	20742A	SBE 32 Trigger Pivot Shaft, Titan	1	1	1
12	30115	N/A	Mach Screw, 2-56 X 1/4 FH, SS	2	2	2
13	30618	N/A	O-ring, Parker 2-106 E962-90 EPR	2	2	2
14	30657	N/A	Mach Screw, 2-56 x 3/8, FH Slot Titanium	1	1	1
15	30659	N/A	Mach Screw, 4-40 x 13/16, FH Slot Titanium	2	2	2
16	30663	N/A	SBE 32 Latch Spring, .012"/MP35N	2	2	2

DATE	REV	DESCRIPTION	AUTH	DR	CK.
07/11/05	.04	Converted to Solidworks drawing	KLP	KLP	
06/22/07	.05	Added 50428 configuration	CB	PC	
5/19/2011	.06	Injection molded trigger lever	CB	PC	

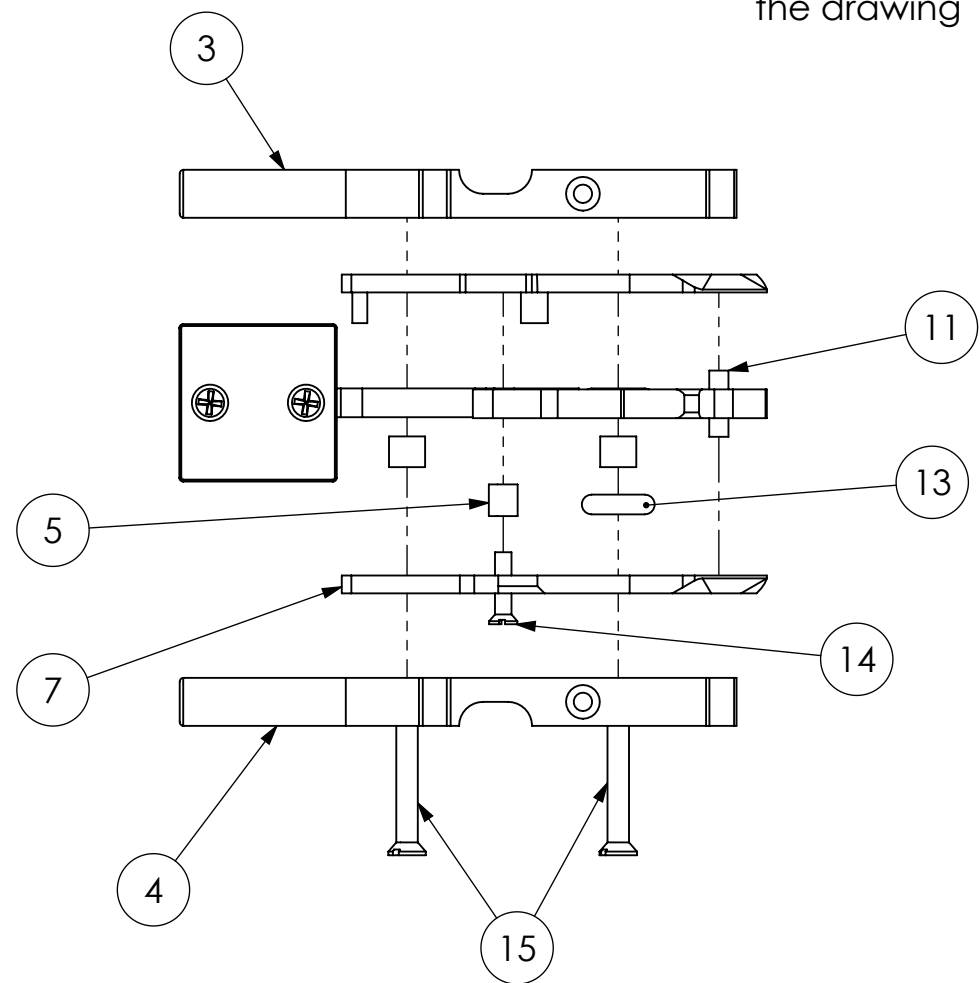
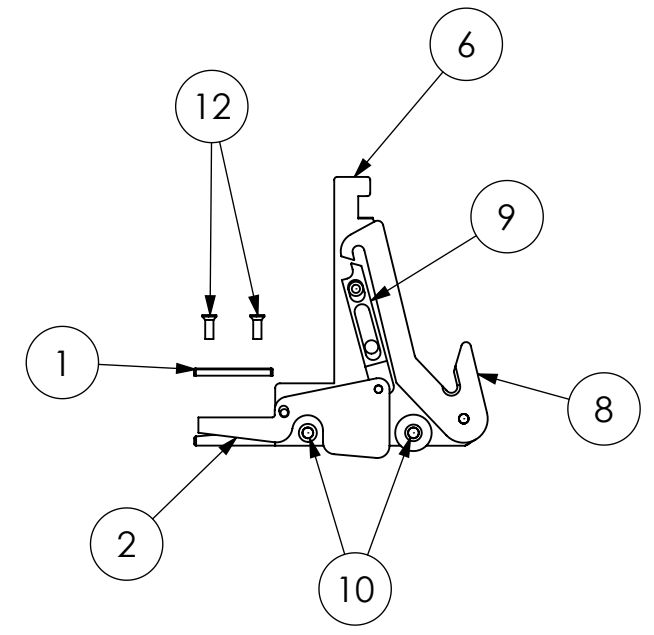
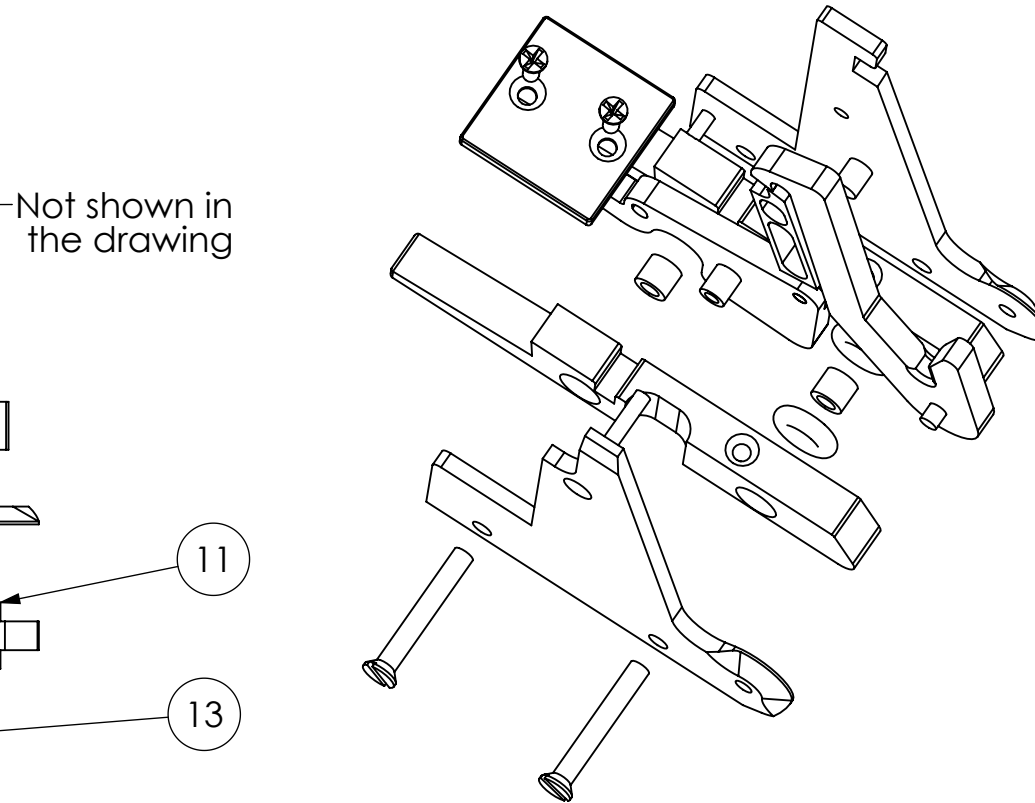
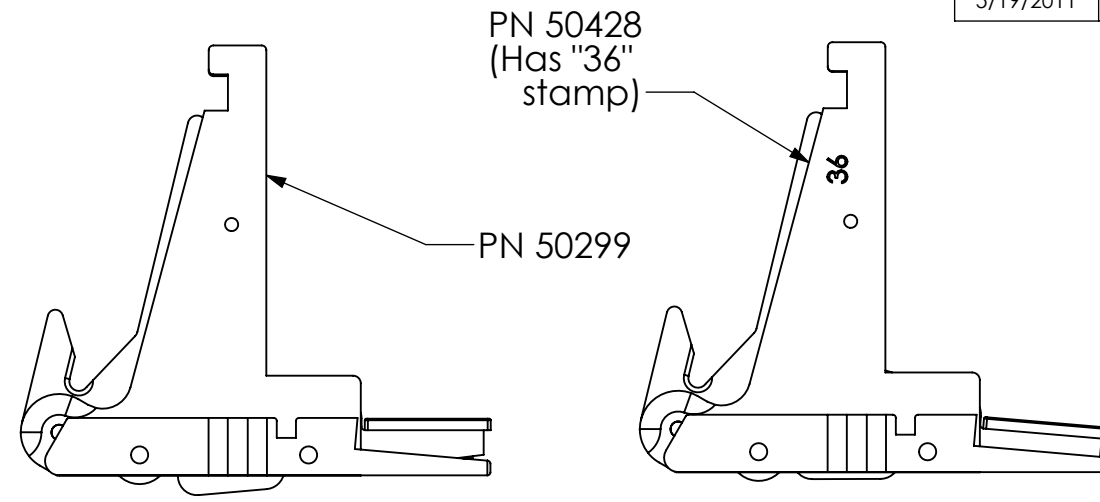

- STEP 1:
Install Inner Parts
- STEP2:
Install Cover Plate
- STEP 3:
Final Latch Assembly
- Step 4:
Install Actuator Disk

UNLESS OTHERWISE SPECIFIED: DIMENSIONS ARE IN INCHES TOLERANCES: FRACTIONAL ± 1/x ANGULAR: ± 0.5° BEND ± .X ± .05 TYP RAD .01 .XX ± .01 .XXX ± .003 MACHINED SURFACES	NAME	DATE	SEA-BIRD ELECTRONICS, INC. 13431 NE 20th Street, Bellevue, WA 98005 425-643-9866
	DRAWN	KLP	
INTERPRET GEOMETRIC TOLERANCING PER: ANSI Y14.5M - 1994	PROPRIETARY AND CONFIDENTIAL THE INFORMATION CONTAINED IN THIS DRAWING IS THE SOLE PROPERTY OF SEA-BIRD ELECTRONICS, INC. ANY REPRODUCTION IN PART OR AS A WHOLE WITHOUT THE WRITTEN PERMISSION OF SEA-BIRD ELECTRONICS, INC. IS PROHIBITED.		TITLE: SBE32 Spare Trigger Assembly
MATERIAL N/A	COMMENTS: DEBUR AND BREAK SHARP EDGES		PART NO. 50299/50428/50496
FINISH N/A	Old Part/Draw Info 50299 / 76064D		SIZE DWG. NO. B 76064.06
DO NOT SCALE DRAWING			SCALE: 1:2 SHEET 1 OF 1