



SEA-BIRD ELECTRONICS, INC.

13431 NE 20th St., Bellevue, Washington 98005 USA
 Telephone: (425) 643-9866 Telex: 292915 SBEI UR
 Fax: (425) 643-9954 Email: seabird@seabird.com

DATE	REV	REVISION RECORD	AUTH	DR	CHK

SBE P/N Varies

SBE 37 SM/SI V3 Cable Clamp Assembly Kit

UNIVERSAL KIT CONTENTS

SBE P/N	Manufacturer P/N	Primary SBE Application	QTY
30633	Washer, 1/4" Split Ring, Ti	Used with cable guide cap and cable clamp securing bolts	2
30634	Washer, 1/4" Flat, Ti	Used with cable guide cap and cable clamp securing bolts	2
30867	Washer, Titanium, #6 Split Lock	Hold cable clamp half to flat area of sensor endcap	1
30900	Mach Screw, 1/4-20x2" Hex Ti	Secure cable guides/clamps to endcaps	2
31019	O-Ring, 2-008 N674-70	Placed on cable clamp 1/4-20 bolts as retainers	2
31066	Cap Screw, 8-32 x 3/4 Socket Head, Titanium	Secure cable guide base to battery/connector endcap	3
31873	Cap Screw, 6-32 x 1/2, Socket Head, Ti	Hold cable clamp half to flat area of sensor endcap	1

SPECIFIC KIT CONTENTS (varies to specified wire size)

SBE P/N	Manufacturer P/N	Primary SBE Application	QTY
Varies	SBE37 Microcat Cable Clamp	Attach to flat surface of sensor ec., clamps to cable	2
Varies	SBE37 Microcat Cable Guide Cap	Attach to cable guide base to lock down mooring cable	1
Varies	SBE37 Microcat Cable Guide Base	Attach to battery/connector endcap to hold cable	1

CLAMP/CAP/BASE SUB-ASSEMBLY COMPONENTS (as seen in attached drawing, 67094E)

SBE P/N	Manufacturer P/N	Primary SBE Application	QTY
30633	Washer, 1/4" Split Ring, Ti	Used with cable guide cap and cable clamp securing bolts	2
30634	Washer, 1/4" Flat, Ti	Used with cable guide cap and cable clamp securing bolts	2
30900	Mach Screw, 1/4-20x2" Hex Ti	Secure cable guides/clamps to end caps	2
31019	O-Ring, 2-008 N674-70	Placed on cable clamp 1/4-20 bolts as retainers	2

KIT PART NUMBERS

SBE P/N	Kit Description
50465	SBE37 Modular Cable Clamp Kit, 1/4"
50466	SBE37 Modular Cable Clamp Kit, 5mm
50467	SBE37 Modular Cable Clamp Kit, 6mm
50468	SBE37 Modular Cable Clamp Kit, 7mm
50469	SBE37 Modular Cable Clamp Kit, 5/16" / 8mm
50470	SBE37 Modular Cable Clamp Kit, 3/8"
50471	SBE37 Modular Cable Clamp Kit, 10mm

SBE P/N	Kit Description
50472	SBE37 Modular Cable Clamp Kit, 11mm
50473	SBE37 Modular Cable Clamp Kit, 1/2"
50474	SBE37 Modular Cable Clamp Kit, 12mm
50475	SBE37 Modular Cable Clamp Kit, 14mm
50476	SBE37 Modular Cable Clamp Kit, 16mm
50477	SBE37 Modular Cable Clamp Kit, 18mm
50478	SBE37 Modular Cable Clamp Kit, 20mm

SBE DRAWING: 67219

TITLE: SBE37SI/SM Microcat V3 Cable Guide/Clamp Assembly

REV:

Sea-Bird Electronics Procedure

PROCEDURE NUMBER: 67219

TITLE: SBE37 SM/SI V3 Cable Clamp Kit Assembly

REVISION:

EFFECTIVE DATE: 8/30/2010

CHECKED BY: PC PAGE 1 of 3



SEA-BIRD ELECTRONICS, INC.

13431 NE 20th St., Bellevue, Washington 98005 USA
Telephone: (425) 643-9866 Telex: 292915 SBEI UR
Fax: (425) 643-9954 Email: seabird@seabird.com

Clamp/Cap/Base Assembly - Usually Done at Seabird

1. One (1) Microcat Threaded Insert (231481) must be glued into each hole in the connector endcap Cable Guide Base (PN varies).
 - a. Clean the surfaces of the Celcon and of the threaded insert with alcohol.
 - b. Use a fine grit sandpaper to roughen the celcon surface area.
 - c. Prime the Celcon with DC-1200.
 - Follow instructions on the can.
 - DC-1200 has a cure time of about 30 minutes.
 - d. Use RTV 734 flowable to glue the insert into position.
2. Mate the cable guide cap to the cable guide base to achieve alignment of the threaded inserts while the RTV cures.
 - a. Align them together so that the circular cut-outs make a hole.
 - b. Use one (1) bolt (30900) for every insert to align them while they cure.
 - c. Slide the bolts into the guide cap from the rounded side.
3. RTV cures at an absolute minimum of 2 hours, but should be allowed to cure overnight.
4. Once the RTV has fully cured, you may remove the cable guide cap.
5. Secure the guide cap to the guide base.
 - a. Align them together so that the circular cut-outs make a hole.
 - b. Place one lock washer (30633) and one flat washer (30634) onto each of the two (2) bolts (30900).
 - c. Slide the bolts into the guide cap from the rounded side.
 - d. Slide one (1) o-ring (31019) over each bolt.
 - e. Secure the guide cap to the guide base with these bolts. The o-rings should seat themselves into the internal countersinks on the blocks.

Install Sensor Endcap Cable Clamp Assembly

1. Install the first clamp guide piece (one of the two identical blocks) onto the endcap.
 - a. Align it so that the threaded circular cut-out faces away from the sensor.
 - b. Secure onto the endcap with one (1) cap screw (31873) and one (1) lock washer (30867).
2. Install the second clamp piece to the first piece.
 - a. Align them so that the circular cut-outs make a hole.
 - b. Place one lock washer (30633) and one flat washer (30634) onto each of two (2) bolts (30900).
 - c. Slide the screws into the cable clamp from the flat side.
 - d. Slide one o-ring (31019) over each bolt.
 - e. Secure the cable clamps together with these bolts. The o-rings should seat themselves into the internal countersinks on the blocks.

SBE DRAWING: 67219

TITLE: SBE37SI/SM Microcat V3 Cable Guide/Clamp Assembly

REV:

Sea-Bird Electronics Procedure

PROCEDURE NUMBER: 67219

TITLE: SBE37 SM/SI V3 Cable Clamp Kit Assembly

REVISION:

EFFECTIVE DATE: 8/30/2010

CHECKED BY: PC PAGE 2 of 3



SEA-BIRD ELECTRONICS, INC.

13431 NE 20th St., Bellevue, Washington 98005 USA
Telephone: (425) 643-9866 Telex: 292915 SBEI UR
Fax: (425) 643-9954 Email: seabird@seabird.com

Install Connector Endcap Guide Cap and Base

1. The guide base installs onto the connector endcap with the rounded side containing the countersunk screw holes facing away from the sensor, and squared end facing the same direction as the clamp guides on the other end.
2. Secure the guide base to the endcap with three (3) cap screws (31066) directly into the endcap,
 - a. Coat the screws in NeverSeez.

Re-Installing the Connector Endcap

1. If you have removed the sensor endcap, either for this procedure, or to replace the batteries, please follow this procedure to properly re-install the endcap.
2. Inspect, clean and re-lubricate the seating surface as necessary.
3. Insert the molex header onto the pins on the battery post.
4. Verify visually that the pins are properly aligned. Microcats have “burned up” before because of the pins have been misalignment.
5. Install the endcap carefully, but tightly, onto the housing, so that the screw holes are both aligned.
6. Inject the holes with DC-4, and secure the housing to the endcap with the screws that were removed.

SBE DRAWING: 67219

TITLE: SBE37SI/SM Microcat V3 Cable Guide/Clamp Assembly

REV:

Sea-Bird Electronics Procedure

PROCEDURE NUMBER: **67219**

TITLE: **SBE37 SM/SI V3 Cable Clamp Kit Assembly**

REVISION:

EFFECTIVE DATE: 8/30/2010

CHECKED BY: PC PAGE 3 of 3

ITEM NO.	PART NUMBER	DRAWING NUMBER	DESCRIPTION	QTY.
1	30633	N/A	Washer, 1/4" Split Ring Lock, Titanium	4
2	30634	N/A	Washer, 1/4" Flat, Titanium	4
3	30867	N/A	Washer, #6 Split Ring Lock, Ti	1
4	30900	N/A	Mach Screw, 1/4-20 x 2" Hex Head Titanium	4
5	31019	N/A	O-ring, Parker 2-008 N674-70	4
6	31066	N/A	Cap Screw, 8-32 X 3/4 Socket Head, Titanium	3
7	31873	N/A	Cap Screw, 6-32 x 3/4" Socket Head, Ti	1

REV.	DATE	ZONE	DESCRIPTION	AUTH	DWG	CHK

D
C
B
A

D
C
B
A

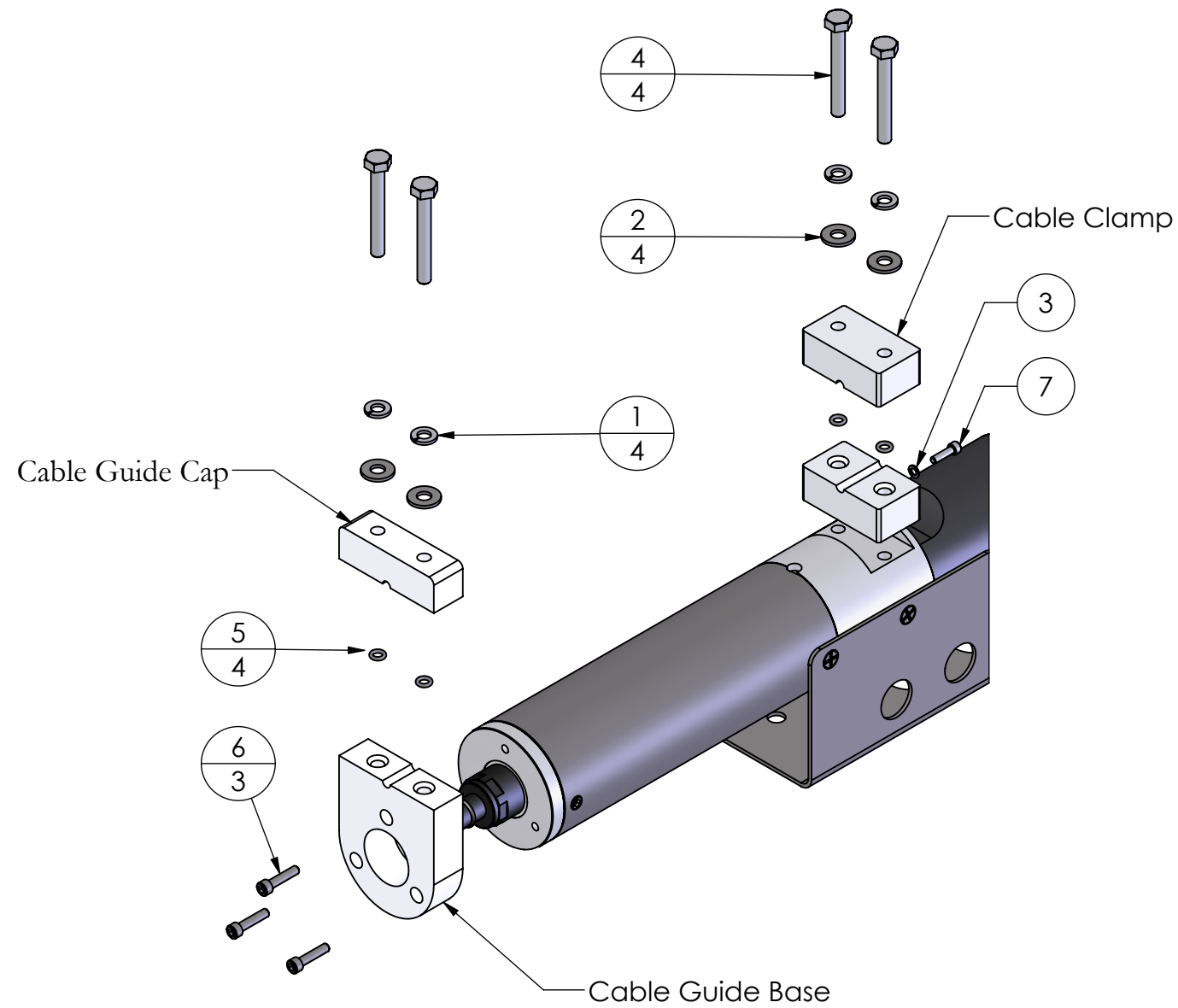

Part No.	Description	Guide Base	Guide Cap	Cable Clamp
50464	SBE37 V3 MSM/MSI Cable Clamp Kit, Generic	234173	231768	231766
50465	SBE37 V3 MSM/MSI Cable Clamp Kit, 1/4"	234197	231483	231461
50466	SBE37 V3 MSM/MSI Cable Clamp Kit, 5mm	234198	232370	232369
50467	SBE37 V3 MSM/MSI Cable Clamp Kit, 6mm	234199	231743	231739
50468	SBE37 V3 MSM/MSI Cable Clamp Kit, 7mm	234200	232194	232192
50469	SBE37 V3 MSM/MSI Cable Clamp Kit, 5/16" / 8mm	234201	231727	231569
50470	SBE37 V3 MSM/MSI Cable Clamp Kit, 3/8"	234202	231723	231722
50471	SBE37 V3 MSM/MSI Cable Clamp Kit, 10mm	234203	231744	231740
50472	SBE37 V3 MSM/MSI Cable Clamp Kit, 11mm	234204	231693	231692
50473	SBE37 V3 MSM/MSI Cable Clamp Kit, 1/2"	234205	231742	231738
50474	SBE37 V3 MSM/MSI Cable Clamp Kit, 12mm	234206	231745	231741
50475	SBE37 V3 MSM/MSI Cable Clamp Kit, 14mm	234207	233239	233238
50476	SBE37 V3 MSM/MSI Cable Clamp Kit, 16mm	234208	231763	231762
50477	SBE37 V3 MSM/MSI Cable Clamp Kit, 18mm	234209	233002	233000
50478	SBE37 V3 MSM/MSI Cable Clamp Kit, 20mm	234210	233353	233351

UNLESS OTHERWISE SPECIFIED:		NAME	DATE	SEA-BIRD ELECTRONICS, INC. 13431 NE 20th Street, Bellevue, WA 98005 425-643-9866
DIMENSIONS ARE IN INCHES TOLERANCES: FRACTIONAL ± 1/x ANGULAR: ± 0.5° BEND ± .X ± .05 TYP RAD .01 .XX ± .01 .XXX ± .003 MACHINED SURFACES		DRAWN	PC 02/14/11	
INTERPRET GEOMETRIC TOLERANCING PER: ANSI Y14.5M - 1994		PROPRIETARY AND CONFIDENTIAL THE INFORMATION CONTAINED IN THIS DRAWING IS THE SOLE PROPERTY OF SEA-BIRD ELECTRONICS, INC. ANY REPRODUCTION IN PART OR AS A WHOLE WITHOUT THE WRITTEN PERMISSION OF SEA-BIRD ELECTRONICS, INC. IS PROHIBITED.		TITLE: SBE37SI/SM Microcat V3 Cable Guide/Clamp Assembly
MATERIAL N/A		COMMENTS: DEBUR AND BREAK SHARP EDGES		PART NO. See Table
FINISH N/A		Old Part/Draw Info N/A / N/A		SIZE B
DO NOT SCALE DRAWING				DWG. NO. 67219
				SCALE: 1:3
				SHEET 1 OF 1

8 7 6 5 4 3 2 1