



APPLICATION NOTE NO. 34

Revised March 2008

Instructions for Use of Conductivity Cell Filling and Storage Device PN 50087 and 50087.1

Figure 1

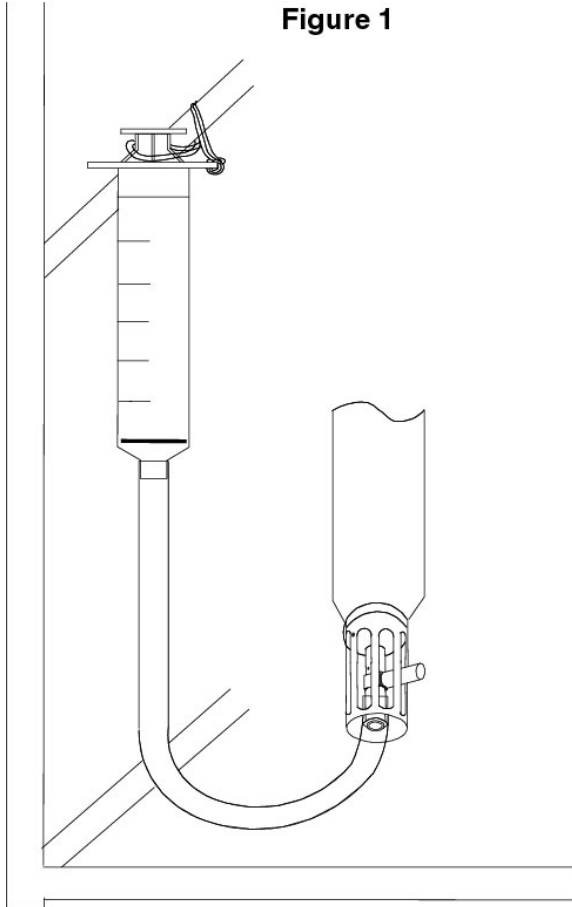

This application note provides instructions for use of PN 50087 / 50087.1 syringe and tubing assembly in rinsing, cleaning, and storing conductivity sensors. The tubing assembly consists of a length of 6.35 mm (1/4 inch) I.D. tube connected by a plastic reducing union to a short piece of 11.1 mm (7/16 inch) I.D. tube. Refer to *Application Note 2D: Instructions for Care and Cleaning of Conductivity Cells* for information on water and solutions recommended for use.

- SBE 9plus, 19plus V2, 25, and 49 are shipped with PN 50087.
- SBE 16plus V2 and 16plus-IM V2 are shipped with PN 50087.1, which includes the parts in 50087, plus hose barbs to replace the anti-foulant cap on the instrument. The hose barbs allow for connection of the tubing for cleaning and storing, as described below.

Note: This procedure can also be used with the SBE 16, 16plus, 16plus-IM, 19, and 19plus, which are no longer in production.

Procedure for Use

1. To fill the conductivity cell, draw about 40-60 cc of solution into the syringe.
2. Connect the plastic tubing to the TC duct intake on the temperature sensor [Figure 1] (or to the open end of the conductivity cell on systems without the TC duct [Figure 2]), and inject solution into the cell and pump plumbing.
 - CTDs with a TC duct or hose barb fitting - remove the plastic reducing union and connect the smaller diameter tubing directly to the TC duct / fitting.
 - CTDs without a TC duct or hose barb fitting (older instruments) - leave the reducing union and large diameter tubing attached and carefully connect the tubing directly to the end of the glass conductivity cell [Figure 2].
3. (If applicable) Loop the rubber band around a bar on the CTD cage and back over the top of the syringe to secure the apparatus for storage.

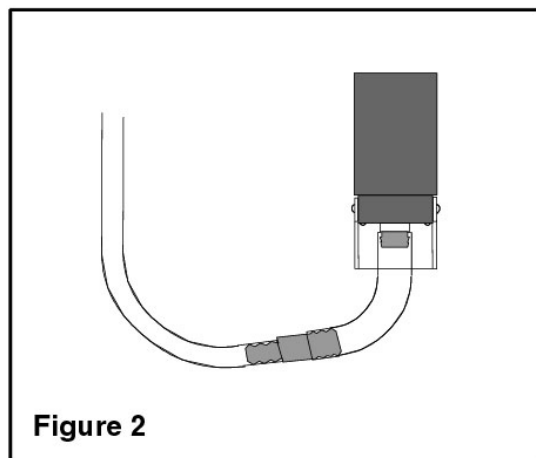

Figure 2

REMOVE THE SYRINGE AND TUBING ASSEMBLY BEFORE DEPLOYMENT!