

SBE 37-IMP MicroCAT Reference Sheet

(see SBE 37-IMP MicroCAT User's Manual for complete details)

Sampling Modes

- **Polled** – On command, wake up, run pump for 1 second, take one sample, transmit data, and go to sleep.
- **Autonomous** – At pre-programmed intervals, wake up, run pump for 1 second, sample, store data in FLASH memory, and go to sleep.
- **Combo** – On command, transmit last Autonomous sampling data.
- **Averaging** – On command, calculate and transmit average of Autonomous sampling data since last request.

Setup

1. Install batteries:
 - A. **Remove modem end cap:** Wipe dry housing/end cap seam. Remove 2 cap screws from end cap, and twist end cap counterclockwise. Pull end cap out. Disconnect Molex connecting to battery pack. Wipe O-ring mating surfaces in housing with lint-free cloth.
 - B. **Remove battery pack and install batteries:** Loosen captured screw in battery pack cover. Use handle to lift battery pack out of housing. Keep handle upright. Unscrew yellow cover plate from top of battery pack assembly. Roll 2 O-rings on side of battery pack out of grooves. Insert batteries into battery pack, and roll 2 O-rings into grooves on side of battery pack. Align pin on battery cover plate PCB with post hole, keep handle upright, and screw yellow cover plate onto battery pack assembly.
 - C. **Reinstall battery pack and modem end cap:** Align D-shaped opening and pins on shaft. Lower battery pack into housing; push gently to mate. Tighten captured screw to secure battery pack in housing. Remove water from O-rings and mating surfaces with lint-free cloth. Inspect O-rings and mating surfaces for dirt, nicks, and cuts. Clean as necessary. Apply light coat of O-ring lubricant to O-ring and mating surfaces. Plug Molex connector together. Fit end cap into housing. Reinstall 2 cap screws.
2. Double click on SeatermV2.exe. In Instruments menu, select *SBE 37 IM*. SeatermIM opens.
3. In Communications menu, select *Configure*. In dialog box, input Comm port and baud rate. Set ID to *Automatically get ID* for 1 MicroCAT on line; set ID to *Use fixed ID* for multiple MicroCATs on line. Click OK.
4. SeatermIM automatically connects to MicroCAT. As it connects, it sends **#iiGetHD** and displays response, and then fills Send Commands window with list of commands for your MicroCAT.
5. Ensure all data has been uploaded from memory, and then send **#iiInitLogging** to make entire memory available for recording. If **#iiInitLogging** is not sent, data will be stored after last recorded sample.
6. Set Date and Time (**#iiDateTime=**).
7. Set up other parameters as desired — see Command Instructions and Command List.

Deployment

1. Attach MicroCAT to insulated mooring cable with Sea-Bird mounting brackets. **MicroCAT is intended for deployment with the sensors at the top for proper operation – see manual for details.** Install (optional) ICC on mooring cable.
2. See MicroCAT manual for SIM wiring and configuration; see IMM manual for IMM wiring and configuration.

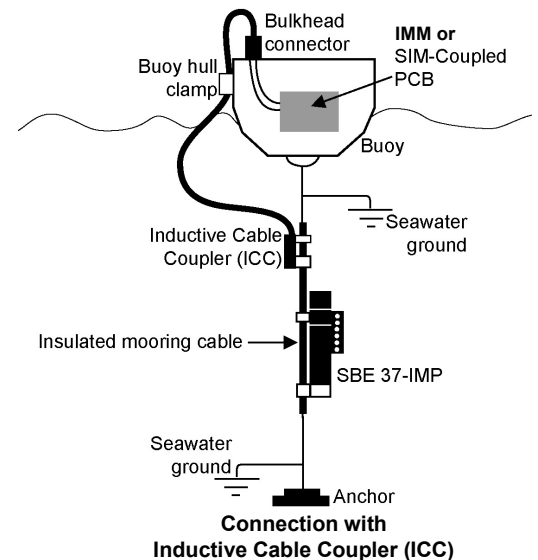
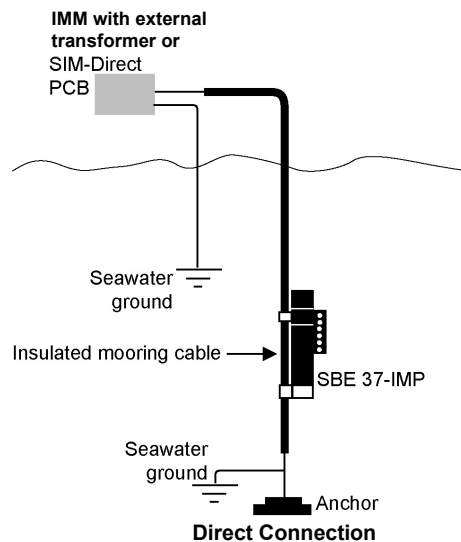

Data Upload

1. Double click on SeatermV2.exe. SeatermV2 opens; in Instruments menu, select *SBE 37 IM*. SeatermIM opens.
2. In Communications menu, select *Configure*. In dialog box, select Comm port and baud rate (factory set to 9600). Set ID to *Automatically get ID* for 1 MicroCAT on line; set ID to *Use fixed ID* for multiple MicroCATs on line. Click OK.
3. SeatermIM automatically connects to MicroCAT. As it connects, it sends **#iiGetHD** and displays response, and then fills Send Commands window with list of commands for your MicroCAT.
4. If sampling autonomously (logging), command MicroCAT to stop logging by sending **#iiStop**.
5. Click Upload menu to upload stored data.
6. SeatermIM prompts you to run SBE Data Processing to convert uploaded .hex file to .cnv file for use by other modules in data processing software. Process file and review data to ensure all data has been uploaded.

Command Instructions and List

- Input commands in upper or lower case letters and register commands by pressing Enter key.
 - MicroCAT sends an error message if invalid command is entered.
 - If new command is not received within 2 minutes after completion of a command, MicroCAT returns to quiescent (sleep) state.
 - If in quiescent (sleep) state, re-establish communications by selecting Connect in SeatermIM's Communications menu.
- Shown below are the commands used most commonly in the field. See the Manual for complete listing and detailed descriptions.

FUNCTION	CATEGORY	COMMAND	DESCRIPTION
SIM Commands	Power-On	PwrOn	Send wakeup tone to all IMs.
		PwrOff	Send power off command to all IMs. Logging and memory retention unaffected.
		AutoPwrOn=x	x=Y : Send PwrOn to IMs when power applied to SIM. x=N : do not.
	Status	DS	Display SIM firmware version and status.
	Communications	Baud=x	x= baud from SIM to computer (1200, 2400, 4800, or 9600). Default 9600.
		DataNnMax=x	x= timeout that applies to Dataii ; default 1000 milliseconds.
		RelayMax=x	x= timeout that applies to all other commands; default 20 seconds.
EchoOn		Echo characters received from computer.	
EchoOff		Do not echo characters received from computer.	
MicroCAT Integrated IMM Commands (ii = MicroCAT ID) <i>See IMM manual for complete details</i>	ID and Group Number	ID?	Get MicroCAT ID (0-99).
		*ID=ii	Set ID to ii (ii =0-99). Only 1 MicroCAT can be on line. Must be sent twice.
		!iiSetGroupNumber=x	Set MicroCAT group number to x (0–9). Group 0 is pre-defined as group of all instruments with integrated IMM.
	Status	!iiGetCD	Get integrated IMM configuration data.
		!iiGetHD	Get integrated IMM hardware data.
		!iiGetSD	Get integrated IMM status data.
	Testing	!iiTestCableCoupler	Test integrity of integrated IMM. Line must be captured before command sent
	Get Data	!iiSetGDataStr=x	x= character string to send to MicroCAT acquisition microcontroller from integrated IMM when GData is sent from surface IMM/SIM.
		GData	Command all integrated IMM's to send command defined by !iiSetGDataStr= , and hold response in buffer until user sends !iiData or Dataii or !iiGetReply .
		!iiData, Dataii, or !iiGetReply	Get data obtained with GData from MicroCAT with ID= ii .
MicroCAT Acquisition Microcontroller Commands (ii = MicroCAT ID)	Status	#iiGetCD	Get and display configuration data.
		#iiGetSD	Get and display status data.
		#iiGetCC	Get and display calibration coefficients.
		#iiGetEC	Get and display event counter data.
		#iiResetEC	Reset event counter.
		#iiGetHD	Get and display hardware data.
		#iiDS	Display status.
	General Setup	#iiDC	Display calibration coefficients.
		#iiDateTime= mmddyyyyhhmmss	Set real-time clock month day year hour minute second.
		#iiBaudRate=x	x= baud rate (600, 1200, 2400, 4800, 9600, 19200, 38400, 57600, 94 115200) for communicating in Serial Mode (through internal RS-232 connector).
		#iiOutputExecutedTag=x	x=Y : output XML Executed and Executing tags. x=N : do not.
		#iiReferencePressure=x	x= reference pressure (decibars) (for MicroCAT without pressure sensor).
	Pump Setup	QS	Place MicroCAT in quiescent (sleep) state; for use in Serial mode only.
		#iiMinCondFreq=	x= minimum conductivity frequency (Hz) for pump turn-on.
		#iiPumpOn	Turn pump on for testing or to remove sediment.
	Memory Setup	#iiPumpOff	Turn pump off, if turned on with #iiPumpOn .
		#iiInitLogging	Initialize logging, setting memory pointer to 0.
	Output Format Setup	#iiSampleNumber=x	x= sample number for first sample when logging begins.
		#iiOutputFormat=x	x=0 : output converted hex data. x=1 : output converted decimal data. x=2 : output converted data, alternate format. x=3 : output raw decimal data. x=4 : output converted decimal data, XML.
		#iiCompatibleMode=x	x=Y : Output data compatible with firmware < 3.0. x=N : do not.
		#iiTxHexTime=x	x=Y : Output date and time with hex data. x=N : do not.
	Autonomous Sampling (logging)	#iiTxSampleNum=x	x=Y : Output sample number with data. x=N : do not.
		#iiSampleInterval=x	x= interval between samples (6 – 21,600 seconds).
		#iiStartNow	Start logging now. Data stored in FLASH memory.
		#iiStartDateTime= mmddyyyyhhmmss	Delayed logging start: month day year hour minute second.
		#iiStartLater	Start logging at delayed start time. Data stored in FLASH memory.
		#iiStop	Stop logging or waiting to log.
		#iiTS	Take sample, output data.
	Polled Sampling (data not stored in FLASH memory unless noted; format specified by #iiOutputFormat= unless noted)	#iiTSR	Take sample, output raw data.
		#iiTSH	Take sample, do not output data.
		#iiTSS	Take sample, store in FLASH memory , output data.
		#iiTSn:x	Take x samples and output data.
		#iiSL	Output last sample.
#iiSLT		Output data from last sample, then take new sample.	
#iiSLTR		Output raw data from last sample, then take new sample.	
Data Upload	#iiDNx	Upload last x scans from memory; can send while logging	
	#iiGetSamples:b,e	Upload data from scan b to e . Send #iiStop before sending.	
	#iiDDb,e	Upload data from scan b to e . Send #iiStop before sending.	