

CTD Deck Unit & PDIM

SBE 36 & PDIM



The **SBE 36 Deck Unit** provides surface power and real-time data acquisition and control for an SBE 19, 19*plus*, 19*plus* V2, 25, or 49 CTD, or SBE 50 Pressure Sensor, interfacing with a **Power and Data Interface Module (PDIM)**. The SBE 36 remains at the surface, while the PDIM is installed on or near the CTD (the term *CTD* refers to the listed CTDs as well as the SBE 50 Pressure Sensor). The system allows for two-way communication for the CTD over a single- or multi-conductor sea cable, and provides ample power for auxiliary sensors that may not otherwise be supportable by a battery-powered CTD.



SBE 36 Deck Unit



Power and Data Interface Module (PDIM)

The rack-mountable SBE 36 supplies DC power for the underwater units, decodes the serial data, and passes the data to a computer. The SBE 36 rear-panel switch permits operation from 120 VAC or 240 VAC 50/60 Hz input power. Other features include:

- NMEA Interface for navigational data - The NMEA Interface decodes messages that are output from navigation devices supporting NMEA 0183 protocol. Decoded Latitude and Longitude are appended to the CTD data stream in the SBE 36, and are passed to the computer for storage and/or display with the CTD data.
- Optional A/D converter for a Surface PAR light sensor - The SBE 36 supplies 12 volts to power the sensor. Surface PAR data is appended to the CTD data stream in the SBE 36, and is passed to the computer for storage and/or display with the CTD data.

The PDIM completes the underwater interface to the CTD. The PDIM housing is anodized aluminum rated to 6,800 meters depth.

POWER SUPPLY AND REGULATION

The SBE 36 presents a constant 250 VDC to the sea cable. The PDIM receives this voltage (minus the sea cable I-R drop) and regulates it to a constant 64 VDC. This 64 VDC is the input for a high-efficiency DC/DC converter, which outputs +15 VDC. The +15 VDC is the supply voltage to the CTD; approximately 1 amp, *in addition to CTD power*, is available at the CTD for support of auxiliary sensors.

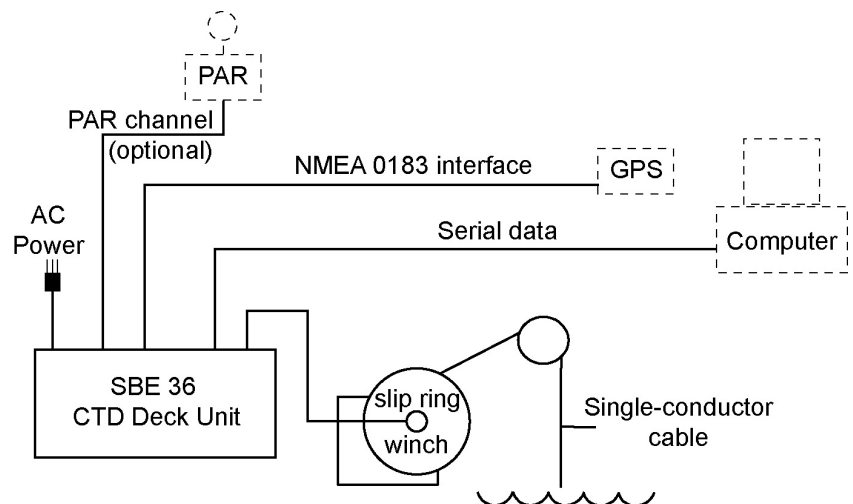

SOFTWARE

The SBE 36 is supplied with a powerful Windows 2000/XP software package, SEASOFT[®] V2, which includes:

- **SEATERM[®]** and **SeatermV2** – terminal programs for communication and data retrieval.
- **Seasave[®]** - real-time data acquisition and display.
- **SBE Data Processing[®]** – filtering, aligning, averaging, and plotting of CTD and auxiliary sensor data and derived variables.

Notes:

- When using the SBE 49: Seasave (real-time data acquisition software) does not allow acquisition of Surface PAR data.
- When using the SBE 50: Seasave does not support this system; real-time data can be viewed in SEATERM (terminal program). NMEA and/or Surface PAR data (if applicable) is output as raw data.

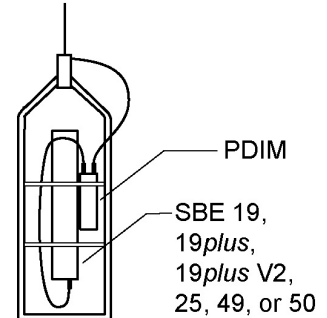

DATA TELEMETRY

A 5760 baud differential-phase-shift-keyed (DPSK) telemetry technique is used for the PDIM to SBE 36 data uplink. A frequency-shift-keyed (FSK) 300 baud modem is used for the SBE 36 to PDIM downlink. Baud rate, data bits, and parity for RS-232 communication between the SBE 36 and computer, and baud rate between the PDIM and CTD, are user-programmable in the SBE 36.

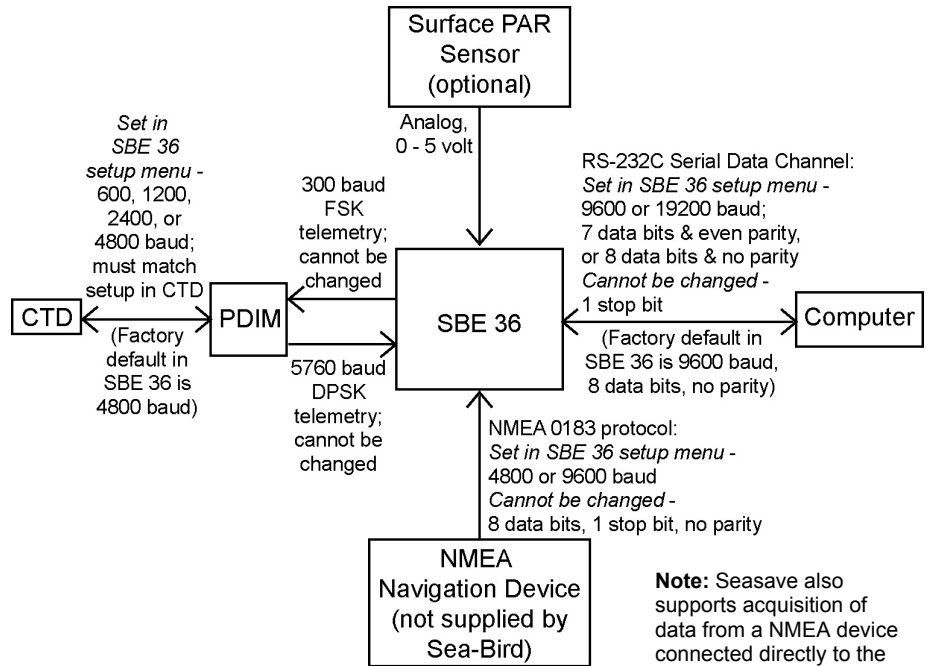

SPECIFICATIONS

Power Requirements

120 VAC at 60 Hz and 1.75A or
240 VAC at 50 Hz and 1A (switchable)

Cable Compatibility

Single or multi-core armored cable up to 10 km long with inner core resistance of up to 350 ohms and armor used as return

SBE 36 Deck Unit Dimensions and Weight

89 mm (3.5 inch) high cabinet with standard
48 mm (1.9 inch) rack mounting brackets

Detailed information:

89 mm high x 432 mm wide x 381 mm deep
(3.5 inches x 17 inches x 15 inches);
Feet add 13 mm (0.5 inches) to height;
Rack mount ears add 51 mm (2 inches) to depth.

9.0 kg (20 lbs)

PDIM Weight

3.6 kg (8 lbs) in air
1.6 kg (3.6 lbs) in water

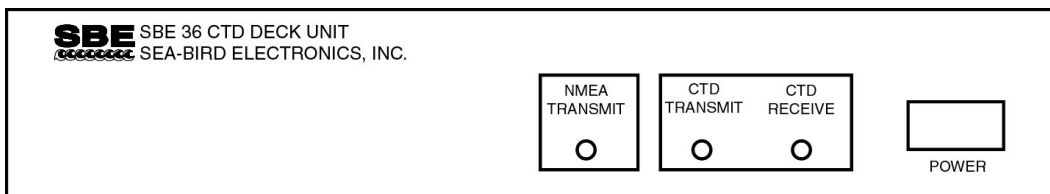
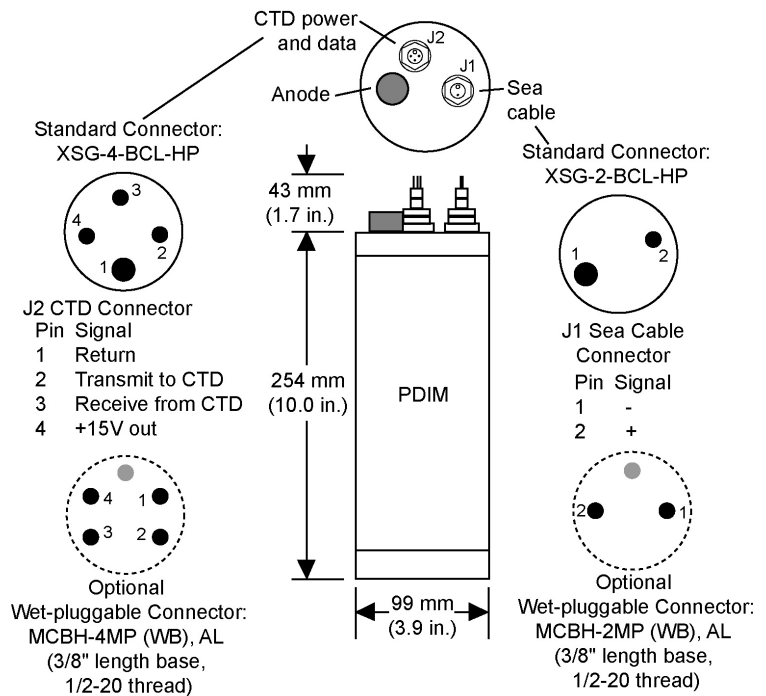

SBE 36 Front Panel

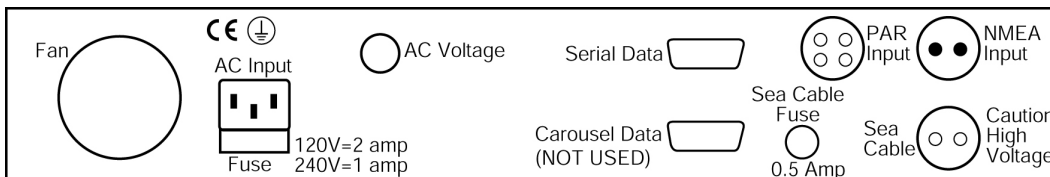

SBE 36 Back Panel

03/10