

SBE 39-IM Temperature (pressure optional) Recorder

With Inductive Modem Interface



Shown with plastic housing and external thermistor

Note: NEW ADDRESS
as of January 2010

User's Manual

Sea-Bird Electronics, Inc.
13431 NE 20th Street
Bellevue, Washington 98005 USA
Telephone: 425/643-9866
Fax: 425/643-9954
E-mail: seabird@seabird.com
Website: www.seabird.com

Manual Version #008, 07-28-10
SEATERM Version 1.59 & later
39-IM Digital Firmware Version 1.1a & later
39-IM Modem Firmware Version 1.98 & later
IMM Firmware Version 1.12 & later
SIM Firmware Version 3.0a & later



Limited Liability Statement

Extreme care should be exercised when using or servicing this equipment. It should be used or serviced only by personnel with knowledge of and training in the use and maintenance of oceanographic electronic equipment.

SEA-BIRD ELECTRONICS, INC. disclaims all product liability risks arising from the use or servicing of this system. SEA-BIRD ELECTRONICS, INC. has no way of controlling the use of this equipment or of choosing the personnel to operate it, and therefore cannot take steps to comply with laws pertaining to product liability, including laws which impose a duty to warn the user of any dangers involved in operating this equipment. Therefore, acceptance of this system by the customer shall be conclusively deemed to include a covenant by the customer to defend, indemnify, and hold SEA-BIRD ELECTRONICS, INC. harmless from all product liability claims arising from the use or servicing of this system.

Table of Contents

Section 1: Introduction	5
About this Manual	5
Quick Start	5
Unpacking SBE 39-IM	6
Shipping Precautions	7
Section 2: Description of SBE 39-IM	8
System Description	8
Specifications	10
Dimensions	11
Sample Timing.....	12
Battery Endurance.....	13
Inductive Modem Module (IMM) or Surface Inductive Modem (SIM)	14
Mooring Cable and Wiring Requirements	16
Section 3: Preparing SBE 39-IM for Deployment	17
Software Installation	17
Power and Communications Test and Setting SBE 39-IM IDs	18
Test Setup with Inductive Modem Module (IMM).....	18
Test Setup with Surface Inductive Modem (SIM).....	19
Test and Set SBE 39-IM ID Using SBE 39-IM with SIM.....	20
Section 4: Deploying and Operating SBE 39-IM	24
Operation Description.....	24
Timeout Descriptions.....	25
Sampling Modes	26
Polled Sampling.....	26
Autonomous Sampling (Logging commands).....	27
Combo Sampling	28
Averaging Sampling	29
Command Descriptions.....	30
SIM Commands.....	31
SBE 39-IM Communication Microcontroller Commands.....	32
SBE 39-IM Acquisition Microcontroller Commands	39
Data Output Formats.....	49
Setup for Deployment.....	50
Attaching SBE 39-IM to Mooring Cable	51
SBE 39-IM without Optional Fairing / Net Fender	51
SBE 39-IM with Optional Fairing / Net Fender	52
System Installation and Wiring.....	53
Installing Optional Inductive Cable Coupler (ICC).....	53
Recovery	54
Uploading Data	55
Upload Using RS-232 (Serial Mode) Telemetry	55
Upload Using Inductive Modem Telemetry (recommended only for uploading small amounts of data).....	59
Processing Data.....	62
Section 5: Routine Maintenance and Calibration	63
Corrosion Precautions.....	63
Battery Replacement.....	63
Pressure Sensor (optional) Maintenance.....	65
Sensor Calibration.....	65
Section 6: Troubleshooting	67
Problem 1: Unable to Communicate with 39-IM.....	67
Problem 2: No Data Recorded	67
Problem 3: Unreasonable T or P Data.....	67

Glossary	68
Appendix I: Functional Description.....	69
Sensors.....	69
Sensor Interface	69
Real-Time Clock.....	69
Memory.....	70
Appendix II: Plot39 Data Plotting Program.....	71
Appendix III: Command Summary	72
Appendix IV: SIM Hookup and Configuration	77
Power Connection.....	77
Interface Option Connection (J1, J2, and J4).....	78
I/O Connector Wiring (JP2).....	78
Inductive Mooring Cable Connection (JP4)	78
Normal Deployed Operation (J5).....	78
Appendix V: Replacement Parts	79
Index.....	80

Section 1: Introduction

This section includes a Quick Start procedure, photos of a standard SBE 39-IM shipment, and battery shipping precautions.

About this Manual

This manual is to be used with the SBE 39-IM Temperature (pressure optional) Recorder. It is organized to guide the user from installation through operation and data collection. We have included detailed specifications, command descriptions, maintenance and calibration information, and helpful notes throughout the manual.

Sea-Bird welcomes suggestions for new features and enhancements of our products and/or documentation. Please contact us with any comments or suggestions (seabird@seabird.com or 425-643-9866). Our business hours are Monday through Friday, 0800 to 1700 Pacific Standard Time (1600 to 0100 Universal Time) in winter and 0800 to 1700 Pacific Daylight Time (1500 to 0000 Universal Time) the rest of the year.

Quick Start

Follow these steps to get a Quick Start using the 39-IM. The manual provides step-by-step details for performing each task:

1. Test Power and Communications and set 39-IM ID (*Section 3: Preparing SBE 39-IM for Deployment*).
2. Deploy 39-IM (*Section 4: Deploying and Operating SBE 39-IM*):
 - A. Install new batteries if necessary.
 - B. Ensure all data has been uploaded, and then set **#iiSampleNum=0** to make entire memory available for recording if desired.
 - C. Set date and time.
 - D. Establish setup and sampling parameters.
 - E. Check status (**#iiDS**) and calibration coefficients (**#iiDC**) to verify setup.
 - F. Autonomous sampling: Set 39-IM to start logging now or in the future.
 - G. Deploying multiple IM instruments: verify 39-IM set to *Prompt ID*.
 - H. Install 39-IM on mooring cable.
 - I. Install Inductive Cable Coupler (optional) on mooring cable.
 - J. Wire system.

Unpacking SBE 39-IM

A typical 39-IM shipment is shown below (one of several available models is pictured).



39-IM - Plastic housing, External thermistor



RS-232 Cable (for uploading data through internal connector)



Spare parts kit – includes spare o-rings and (25) desiccant bags



User Manual



Software, and Electronic Copies of Software Manuals and User Manual

Note:
SBE 39-IM can be used with SIM or with IMM; IMM not shown.

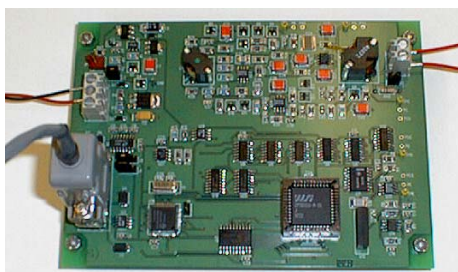

Surface Inductive Modem (SIM) PCB (1 per mooring, optional)



I/O Cable (included with SIM)

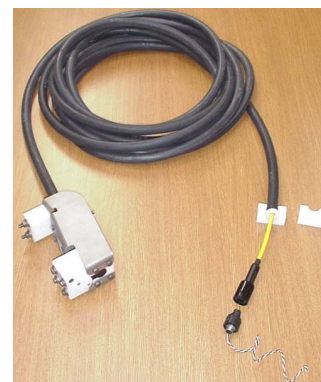

Inductive Cable Coupler (ICC) (optional with SIM, 1 per mooring)

Shipping Precautions

WARNING!

Do not ship spare batteries by passenger aircraft.

For its main power supply, the SBE 39-IM uses two 3.6-volt AA lithium batteries (Saft LS14500). The SBE 39-IM was shipped from the factory with the lithium batteries inside the instrument. When shipped in this manner, the lithium batteries are **not** considered Dangerous/Hazardous Goods, and may be shipped via commercial aircraft (those governed by DOT or IATA, including passenger airlines, or cargo carriers such as FedEx, DHL, UPS, etc.) if no more than the two batteries required to operate the instrument are included in the shipment (i.e., no spares are included). For international shipments, the airway bill must include the phrase, “Non Restricted Per Special Provision A45”.

Note:

Remove the batteries before returning the SBE 39-IM to Sea-Bird (see *Battery Replacement* in *Section 5: Routine Maintenance and Calibration*). Do not return the used batteries to Sea-Bird when shipping the SBE 39-IM for repair or recalibration. All setup information is preserved in EEPROM when the batteries are removed.

IMPORTANT NOTE:

Do not ship spare lithium batteries via passenger aircraft. Refer to *Lithium Battery Shipping Guidelines* for background information on the applicable regulations as well as Sea-Bird’s interpretation of those regulations, how they apply to the batteries in our equipment, and how we package and label our equipment.

Section 2: Description of SBE 39-IM

This section describes the functions and features of the SBE 39-IM, including specifications and dimensions, sample timing, battery endurance, and mooring requirements.

System Description



SBE 39-IM with external thermistor

Note:
For detailed information on inductive modem systems, see *Real-Time Oceanography with Inductive Moorings*, at www.seabird.com under Technical Papers.

The SBE 39-IM is a high-accuracy temperature recorder (pressure optional) with internal batteries and non-volatile memory. It uses an Inductive Modem (IM) to transmit data and receive commands over a plastic-jacketed steel mooring cable (or other insulated conductor), using differential-phase-shift-keyed (DPSK) telemetry. No electrical cables or connectors are required. The 39-IM's built-in inductive coupler (split toroid) and cable clamp provide easy and secure attachment to the mooring cable. Designed for moorings and other long-duration, fixed-site deployments, 39-IMs have non-corroding plastic (600 meters [1960 feet]) or titanium housings (10,500 meters [34,400 feet]).

Communicating with one or more 39-IMs requires the use of a Sea-Bird Inductive Modem Module (IMM) or Surface Inductive Modem (SIM). These devices provide a standard serial interface between the user's computer or other controlling device and up to 100 SBE 39-IMs (or other IM-compatible instruments), coupled to a single cable. The user can communicate with these devices via full-duplex RS-232C or half-duplex RS-485. Commands and data are transmitted half-duplex between these devices and the 39-IM.

Note:

Half-duplex communication is **one-direction** at a time (i.e., you cannot send commands and receive data at the same time). For example, if the IMM or SIM commands a 39-IM to upload data, nothing else can be done while the data is being sent – the data upload cannot be stopped, and commands cannot be sent to other IM instruments on the line.

Commands can be sent to the 39-IM to provide status display, data acquisition setup, data retrieval, and diagnostic tests. User-selectable operating modes include:

- **Polled sampling** – On command, the 39-IM takes one sample and transmits data.
- **Autonomous sampling** – At pre-programmed 10-second to 8.3-hour intervals, the 39-IM wakes up, samples, stores data in memory, and powers off (enters quiescent state).
- **Combo sampling** – Autonomous sampling is in progress, and the IMM or SIM can request the transmission of the last stored data.
- **Averaging sampling** – Autonomous sampling is in progress, and the IMM or SIM can request the transmission of the average of the individual data samples acquired since its last request.

ASCII data upload can be accomplished without opening the 39-IM housing, using the inductive modem telemetry (baud rate between 39-IM and IMM or SIM is always 1200 baud). Alternatively, by opening the 39-IM housing to access the internal RS-232 serial connector, fast binary upload of large data sets can be performed at rates up to 115,200 baud.

Calibration coefficients stored in EEPROM allow the 39-IM to transmit data in engineering units.

The SBE 39-IM retains the temperature sensor used in the SBE 39 Temperature Recorder. The 39-IM's thermistor has a long history of exceptional accuracy and stability (typical drift is less than 0.002 °C per year). Two temperature sensor configurations are offered:

- **Standard** - ruggedized model with the thermistor embedded in the titanium end cap (time constant approximately 25 seconds).
- **Optional** - model with external thermistor in a pressure-protected sheath (time constant approximately 0.5 seconds) for use when fast sampling is required.

The 39-IM's optional pressure sensor, developed by Druck, Inc., has a superior design that is entirely different from conventional 'silicon' types in which the deflection of a metallic diaphragm is detected by epoxy-bonded silicon strain gauges. The Druck sensor employs a micro-machined *silicon diaphragm* into which the strain elements are implanted using semiconductor fabrication techniques. Unlike metal diaphragms, silicon's crystal structure is perfectly elastic, so the sensor is essentially free of pressure hysteresis. Compensation of the temperature influence on pressure offset and scale is performed by the 39-IM's CPU.

SBE 39-IM with external thermistor and optional fairing



The 39-IM's optional fairing / net fender provides protection from snagging by nets and fishing lines.

Future upgrades and enhancements to the SBE 39-IM firmware can be easily installed in the field through a computer serial port and the internal RS-232 serial connector inside the 39-IM, without the need to return the 39-IM to Sea-Bird.

The 39-IM is supplied with a powerful Win 2000/XP software package, SEASOFT[®] V2, which includes:

- **Deployment Endurance Calculator**– program for determining deployment length based on user-input deployment scheme, instrument power requirements, and battery capacity.
- **SEATERM** - terminal program for easy communication and data retrieval.
- **Plot39** - program specifically for plotting SBE 39 and 39-IM data.
- **SBE Data Processing** - SBE Data Processing includes many post-processing modules; modules applicable to the SBE 39 are ASCII Out (export files for other programs) and Sea Plot (plot data).

Notes:

- Help files provide detailed information on the software.
- A separate software manual on CD-ROM contains detailed information on the setup and use of SBE Data Processing.
- Sea-Bird supplies the current version of our software when you purchase an instrument. As software revisions occur, we post the revised software on our FTP site. See our website (www.seabird.com) for the latest software version number, a description of the software changes, and instructions for downloading the software from the FTP site.

Specifications

	Temperature (°C)	Pressure (optional)									
Measurement Range	-5 to +35	0 to full scale range: 20 / 100 / 350 / 600 / 1000 / 2000 / 3500 / 7000 m <i>Pressure expressed in meters of deployment depth capability.</i>									
Initial Accuracy	0.002	0.1% of full scale range									
Typical Stability	0.0002 per month	0.05% of full scale range per year									
Resolution	0.0001	0.002% of full scale range									
Sensor Calibration	-1 to +32	Ambient pressure to full scale range in 5 steps									
Memory	64M byte non-volatile FLASH memory (32M byte usable)										
Data Storage	Temperature: 3 bytes/sample. Time: 4 bytes/sample. Pressure (optional): 4 bytes/sample <table border="1"> <thead> <tr> <th><u>Recorded Parameters</u></th> <th><u>Memory Space (total number of samples)</u></th> </tr> </thead> <tbody> <tr> <td>T and time</td> <td>4,790,000</td> </tr> <tr> <td>T, P, and time</td> <td>3,050,000</td> </tr> </tbody> </table>		<u>Recorded Parameters</u>	<u>Memory Space (total number of samples)</u>	T and time	4,790,000	T, P, and time	3,050,000			
<u>Recorded Parameters</u>	<u>Memory Space (total number of samples)</u>										
T and time	4,790,000										
T, P, and time	3,050,000										
Real-Time Clock	Watch-crystal type 32,768 Hz; Accuracy 5 seconds/month.										
Internal Batteries	Two 3.6-volt, non-hazardous, AA lithium batteries, manufactured by Saft (LS14500) or Tadiran. NOTE: Do not use AA alkaline batteries.										
Current Consumption	<i>Quiescent Current:</i> 20 microAmps <i>Communications Current:</i> 0.6 milliAmp <i>Communications Time:</i> 0.5 seconds per sample <i>Acquisition Current (per sample):</i> T and time only: 3.5 milliAmp for 1.2 seconds T, P, and time: 6 milliAmp for 1.8 seconds <i>Transmit Current (for polled sampling):</i> <table border="1"> <thead> <tr> <th></th> <th>Low Power</th> <th>Full Power</th> </tr> </thead> <tbody> <tr> <td>No pressure sensor</td> <td>1.3 milliAmp for 1.75 sec</td> <td>5.3 milliAmp for 1.75 sec</td> </tr> <tr> <td>With pressure sensor</td> <td>1.3 milliAmp for 2.35 sec</td> <td>5.3 milliAmp for 2.35 sec</td> </tr> </tbody> </table>			Low Power	Full Power	No pressure sensor	1.3 milliAmp for 1.75 sec	5.3 milliAmp for 1.75 sec	With pressure sensor	1.3 milliAmp for 2.35 sec	5.3 milliAmp for 2.35 sec
	Low Power	Full Power									
No pressure sensor	1.3 milliAmp for 1.75 sec	5.3 milliAmp for 1.75 sec									
With pressure sensor	1.3 milliAmp for 2.35 sec	5.3 milliAmp for 2.35 sec									
Battery Endurance	More than 400,000 samples										
Materials	<i>Standard:</i> PET plastic pressure case rated at 600 meters (1960 feet) <i>Optional:</i> Titanium pressure case rated at 10,500 meters (34,400 feet)										
Weight	<i>Plastic housing with embedded thermistor:</i> In air: 1.1 kg (2.4 lbs); In water: 0.5 kg (1.0 lbs) <i>Titanium housing with embedded thermistor:</i> In air: 1.6 kg (3.6 lbs), In water: 1.0 kg (2.2 lbs)										

Note:

If the 39-IM is logging data and the battery voltage is less than 5.8 volts for 10 consecutive scans, the 39-IM halts logging and displays a low battery indication in the data.

Dimensions

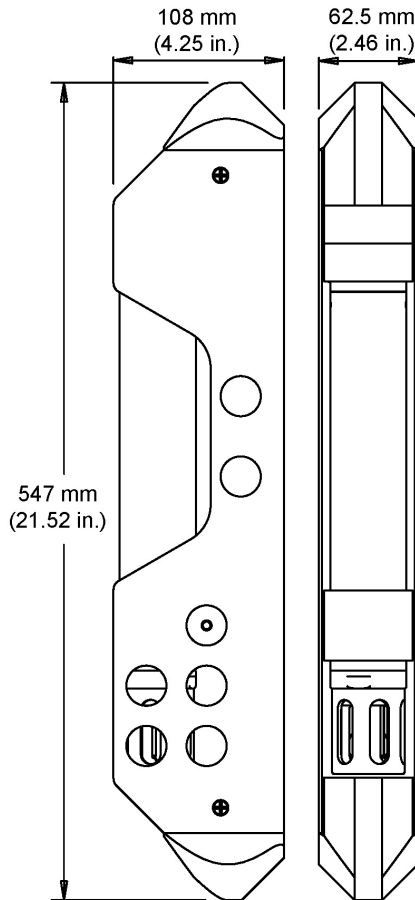
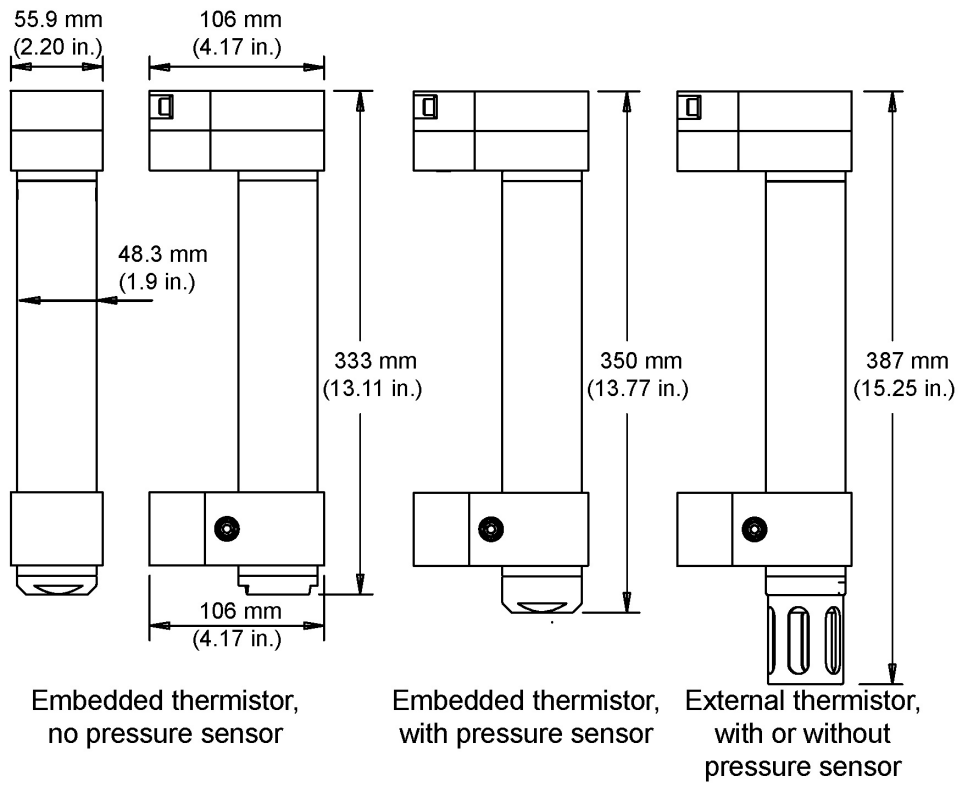

39-IM with Fairing
(shown with external thermistor)

Sample Timing

- **Power On Time** for each sample (autonomous sampling):
39-IM without Pressure sensor: 1.2 seconds
39-IM with Pressure sensor: 1.8 seconds

- **!iiData Time:**

	39-IM without pressure sensor	39-IM with pressure sensor
End of !iiData to beginning of reply	170 msec	170 msec
End of !iiData to end of reply	638 msec	713 msec

- **Communications Time**, which is the time to request and transmit data from each 39-IM to the computer/controller:
0.5 seconds

Note:

Minimum time between polled sampling commands to 39-IMs on a mooring is approximately 1.9 seconds (39-IMs without pressure sensor) or 2.5 seconds (39-IMs with pressure sensor).

- **Transmit Time**, which is the time the 39-IM transmitter is powered on for each *polled* sample:
39-IM without Pressure sensor: 1.75 seconds
39-IM with Pressure sensor: 2.35 seconds

Battery Endurance

Notes:

- If the 39-IM is logging data and the battery voltage is less than 5.8 volts for ten consecutive scans, the 39-IM halts logging and displays a low battery indication in the data.
- **See *Specifications* above for data storage limitations.**

Note:

Minimum time between **polled sampling** commands to 39-IMs on a mooring is approximately 1.9 seconds (39-IMs without pressure sensor) or 2.5 seconds (39-IMs with pressure sensor). ***Polled sampling is a very inefficient use of the 39-IM's battery power; autonomous sampling is much more efficient, as shown in the examples below.***

Nominal battery capacity is 2.25 Amp-hours.

For planning purposes, use a conservative value of 2.0 Amp-hours.

Current consumption is as follows:

- Sampling (acquisition) current -
 39-IM *without pressure* = (3.5 mA * 1.2 seconds) = 4.2 mA-sec/sample
 39-IM *with pressure* = (6 mA * 1.8 seconds) = 10.8 mA-sec/sample
- Communications current is 0.6 mA. Assuming the fastest practical interrogation scheme (wake all IM instruments on mooring, send **GData**, send **!iiData** to each IM instrument, and power off all IM instruments), the communications current is drawn for approximately 0.5 seconds **per IM instrument on the mooring**. Each IM instrument on the mooring draws this current while any of the IM instruments are being queried to transmit data. Other interrogation schemes require more time.

- Transmit current (for *polled sampling*) -

	Low Power	Full Power
No pressure sensor	1.3 mA for 1.75 sec	5.3 mA for 1.75 sec
With pressure sensor	1.3 mA for 2.35 sec	5.3 mA for 2.35 sec

Transmit current is in addition to sampling and communications currents.

- Quiescent current is 20 μ A (0.18 Amp-hours per year).

So, battery endurance is highly dependent on the application. Examples are shown below. **For most cases, you can use the Deployment Endurance Calculator** to determine the maximum deployment length, instead of performing the calculations by hand.

Example 1: 10 39-IMs with pressure are deployed on a mooring, set up to sample autonomously every 5 minutes (12 samples/hour), and the average is requested by the computer every hour. How long can they be deployed?

Sampling current for 39-IM **with pressure** = 10.8 mA-sec/sample = 0.0108 Amp-sec/sample
In 1 hour, sampling current = 12 * 0.0108 Amp-sec/sample = **0.1296 Amp-sec/hour**

Communication current = 0.6 mA = 0.0006 Amps
Communication current / query = 0.0006 Amps * 0.5 sec/IM to be queried * 10 IMs on mooring = 0.0030 Amp-sec/query
Communication current / hour = 0.003 Amp-sec/query * 1 query/hour = **0.0030 Amp-sec/hour**

Quiescent current = 20 μ A = 0.02 mA = 0.00002 Amps
In 1 hour, quiescent current = 0.00002 mA * 3600 seconds/hour = **0.0720 Amp-sec/hour**

In 1 hour, the 39-IM takes 12 samples and transmits average to computer:
Current consumption / hour = 0.1296 + 0.0030 + 0.0720 = **0.2046 Amp-sec/hour**
Capacity = (2 Amp-hours * 3600 seconds/hour) / (0.2046 Amp-sec/hour) = 35,190 hours = 1466 days = 4.0 years
However, Sea-Bird recommends that batteries should not be expected to last longer than 2 years in the field.
Total number of samples = 35,190 hours * 12 samples/hour = 422,280 samples

Example 2: Same as Example 1, but #iiDNx command will be used once per hour to upload the last 12 samples in memory (i.e., all the samples that have been taken since the last communication). **Note that the Deployment Endurance Calculator is not compatible with this type of query; calculation by hand is required.**

Communication current = 0.6 mA = 0.0006 Amps
Each scan has this format: ttt.tttt, pppp.ppp, dd mmm yyyy, hh:mm:ss
(total of 43 characters, including carriage return and line feed)
Time required to upload 1 sample = (number of characters * 10 bits/character) / baud rate =
(43 * 10) / 1200 baud = 0.36 sec/sample
Time required to upload 12 samples = 0.36 sec/sample * 12 samples = 4.32 sec
Communication current consumption / query = 0.0006 Amps * 4.32 sec/39-IM to be queried * 10 39-IMs on mooring
=0.0259 Amp-sec/hour

From above, Sampling consumption = **0.1296 Amp-sec/hour**
From above, Quiescent consumption = **0.0720 Amp-sec/hour**
In 1 hour, the 39-IM takes 12 samples and transmits average to computer:
Current consumption / hour = 0.1296 + 0.0259 + 0.0720 = **0.2275 Amp-sec/hour**
Capacity = (2 Amp-hours * 3600 seconds/hour) / (0.2275 Amp-sec/hour) = 31,648 hours = 1318 days = 3.6 years
However, Sea-Bird recommends that batteries should not be expected to last longer than 2 years in the field.
Total number of samples = 31,648 hours * 12 samples/hour = 379,776 samples

Example 3: 10 39-IMs with pressure are deployed on a mooring, set up with full power transmit setting (**SetFullPwrTx**), and each is poll sampled (**TS**) every 5 minutes (12 samples/hour). How long can they be deployed?

Sampling current same as Example 1 = **0.1296 Amp-sec/hour**

Communication current = 0.6 mA = 0.0006 Amps.
Assume fastest querying possible, with 2.5 seconds between **TS** command for each 39-IM.
Communication current / query = 0.0006 Amps * 2.5 sec/IM to be queried * 10 IMs on mooring = 0.0150 Amp-sec/query
Communication current / hour = 0.0150 Amp-sec/query * 12 queries/hour = **0.1800 Amp-sec/hour**

Transmit current for full power setting = 5.3 mA = 0.0053 Amps
Transmit current / query = 0.0053 Amps * 2.35 seconds for 39-IM with pressure sensor = 0.0125 Amp-sec/query
Transmit current / hour = 0.0125 Amp-sec/query * 12 samples/hour = **0.1500 Amp-sec/hour**

Quiescent current same as Example 1 = 0.072 Amp-sec/hour

In 1 hour, the 39-IM takes 12 samples and transmits each sample to computer:
Current consumption / hour = 0.1296 + 0.1800 + 0.1500 + 0.072 = **0.5316 Amp-sec/hour**
Capacity = (2 Amp-hours * 3600 seconds/hour) / (0.5316 Amp-sec/hour) = 13,544 hours = 564 days = 1.55 years
Total number of samples = 13,544 hours * 12 samples/hour
= 162,528 samples << 422,280 samples for Example 1 or 379,776 samples for Example 2

Inductive Modem Module (IMM) or Surface Inductive Modem (SIM)

An Inductive Modem Module or Surface Inductive Modem is required for communication with the SBE 39-IM. These devices impress (*modulate*) the mooring cable with a DPSK signal that is encoded with commands received from the computer/controller. The encoded signals are *demodulated* by 39-IMs coupled to the cable. Replies from 39-IMs are similarly coupled to the cable and *demodulated* by these devices.

The SBE 39-IM requires a minimum of 20 ohms impedance.

Inductive Modem Module (IMM)

The IMM must be supplied with 7 to 24 volts DC power. The maximum operating current is approximately 15 milliAmps.

The user's computer or buoy controller is interfaced via RS-232 (optional RS-485) serial port to the IMM. The standard interface protocol between the computer/controller and IMM is 1200, 2400, 4800, 9600, 19200, or 38400 baud (user-selectable); 8 data bits; no parity; RS-232C.

The DPSK communication link between the IMM and IM instrument(s) is half-duplex, so talking and listening is sequential only. Although the data link between the IMM and the user's computer/controller is established at 1200, 2400, 4800, 9600, 19200, or 38400, the DPSK modem communication between IMM and IM instruments always operates at 1200 baud.

See the IMM Manual for details.

Surface Inductive Modem (SIM)

The SIM must be supplied with 7 to 25 volts DC power. The maximum operating current is approximately 30 milliAmps.

The user's computer or buoy controller is interfaced via RS-232 (or RS-485) serial port to the SIM. The standard interface protocol between the computer/controller and SIM is 1200, 2400, 4800, or 9600 baud (user-selectable); 8 data bits; no parity; RS-232C; with echoing of characters.

The DPSK communication link between the SIM and IM instrument(s) is half-duplex, so talking and listening is sequential only. Although the data link between the SIM and the user's computer/controller is established at 1200, 2400, 4800, or 9600 baud, the DPSK modem communication between SIM and IM instruments always operates at 1200 baud.

Mooring Cable and Wiring Requirements

Note:

For wiring, see applicable document:

- IMM manual. **OR**
- *Appendix IV: SIM Hookup and Configuration.*

The standard 39-IM can mechanically accommodate mooring cables up to 16 mm (0.63 inches) in diameter. Clamps for specific diameters are available, or can be supplied on a custom basis. Suitable mooring cables use steel wire rope with a polypropylene or polyethylene-insulating jacket. The system operates without data errors using up to 10,500 meters (34,400 feet) of 3 mm (0.12 inches) or larger cable.

The mooring cable must provide connection to seawater ground below the deepest IM instrument. Terminating the wire with a metallic eye or clevis readily provides this connection.

The mooring cable must also provide for connection to the IMM or SIM.

- In a direct connection (typical cable-to-shore applications), the bottom end of the wire is grounded to seawater, and the top end remains insulated to the connection to the IMM or SIM. A second wire from the IMM or SIM connects to seawater ground, completing the circuit.
- In typical surface buoys it is often preferable to connect the jacketed mooring wire to the buoy with a length of chain, grounding the jacketed wire to seawater at each end. An Inductive Cable Coupler (ICC) connects the IMM or SIM to the jacketed wire above the uppermost IM instrument and below the point where the wire is grounded.

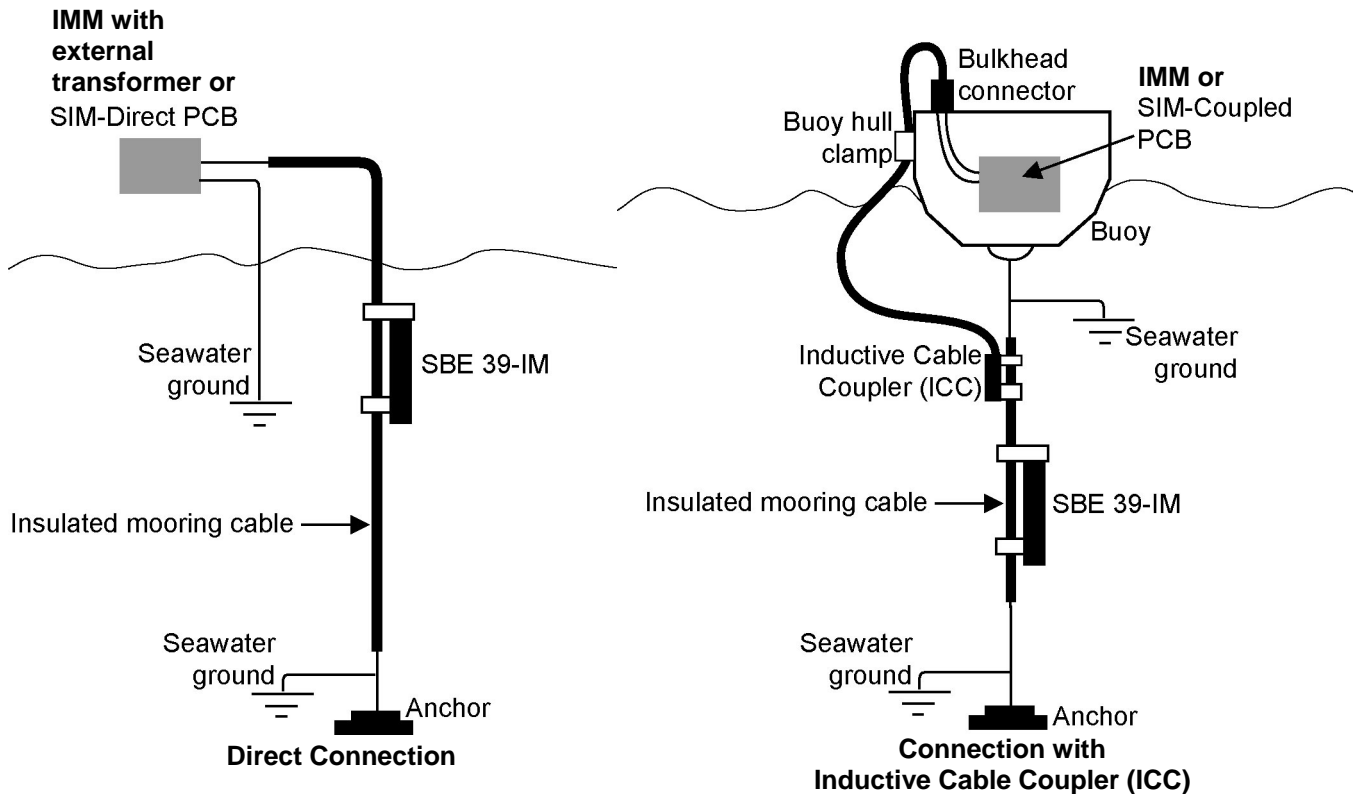

Section 3:

Preparing SBE 39-IM for Deployment

This section describes software installation, the pre-check procedure for preparing the 39-IM for deployment, and setting the 39-IM ID.

Software Installation

Notes:

- Help files provide detailed information on the software. A separate software manual on the CD-ROM contains detailed information on SBE Data Processing.
- It is possible to use the SBE 39 without the SEATERM terminal program by sending direct commands from a dumb terminal or terminal emulator, such as Windows HyperTerminal.
- Sea-Bird supplies the current version of our software when you purchase an instrument. As software revisions occur, we post the revised software on our FTP site. See our website (www.seabird.com) for the latest software version number, a description of the software changes, and instructions for downloading the software from the FTP site.

Sea-Bird recommends the following minimum system requirements for installing the software: Windows 2000 or later, 500 MHz processor, 256 MB RAM, and 90 MB free disk space for installation. Although SEASOFT V2 was designed to work with a PC running Win 2000/XP; extensive testing has not shown any compatibility problems when using the software with a PC running Windows Vista.

If not already installed, install Sea-Bird software programs on your computer using the supplied software CD:

1. Insert the CD in your CD drive.
2. Install software: Double click on **SeasoftV2_date.exe** (*date* is the date that version of the software was created). Follow the dialog box directions to install the software. The installation program allows you to install the desired components. Install all the components, or just install Deployment Endurance Calculator (battery endurance calculator), SEATERM (terminal program for the SBE 39), Plot39 (plotting software), and SBE Data Processing (data processing).
3. Follow the dialog box directions to install the software.

The default location for the software is c:\Program Files\Sea-Bird. Within that folder is a sub-directory for each program.

Power and Communications Test and Setting SBE 39-IM IDs

Note:

Sea-Bird ships the 39-IM with two 3.6-volt AA lithium batteries installed. See *Section 5: Routine Maintenance and Calibration* to replace the batteries.

The power and communications test will verify that the system works, prior to deployment.

Note:

If more than one IM instrument is on-line when you set the ID, all IM instruments will be set to the same ID. The inductive modem receivers in IM instruments are very sensitive; two IM instruments that are side-by-side will take the same ID, even if one of them is not on the IM loop. **Therefore, separate IM instruments by at least 2 meters when setting IDs.**

Test Setup with Inductive Modem Module (IMM)

1. Loop insulated wire through the 39-IM's modem coupling core to simulate a mooring cable. Place the other end of the loop through the IMM test coupler (supplied with the IMM) or the ICC. Connect the wire ends from the IMM test coupler or ICC to the IMM's mooring cable terminals (J1) (see IMM Manual).
2. The 39-IM requires a minimum of 20 ohms impedance.
3. Connect the IMM to your computer's serial port and to a 7 – 24 VDC power supply using the cable supplied with the IMM. A maximum of 15 mA is required.

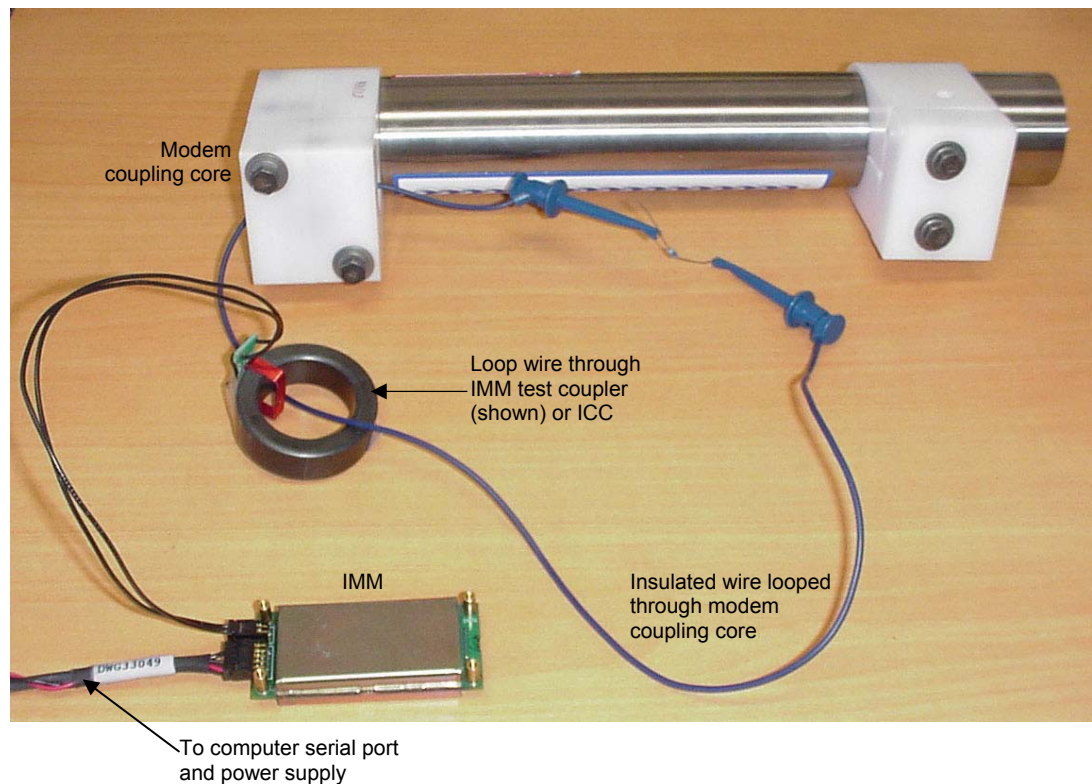

Test Setup with Surface Inductive Modem (SIM)

Note:

For testing and setup, an ICC is not required, even if using SIM-Coupled.

Notes:

- **If more than one IM instrument is on-line when you set the ID, all IM instruments will be set to the same ID.** The inductive modem receivers in IM instruments are very sensitive; two IM instruments that are side-by-side will take the same ID, even if one of them is not on the IM loop. **Therefore, separate IM instruments by at least 2 meters when setting IDs.**
- **Important! For Normal Deployed operation, reinstall the jumper across J5.**

1. Loop insulated wire through the 39-IM's modem coupling core to simulate a mooring cable. Connect the test wire ends to the SIM's mooring cable terminals (JP4). (See *Appendix IV: SIM Hookup and Configuration*.)
2. On the SIM, remove the jumper on J5 (see *Appendix IV*). This inserts a 1K resistor in series with the inductive loop and reduce signal amplitude, preventing 39-IMs that are near but not attached to the inductive loop from responding to commands (especially important when sending *ID=).
3. The 39-IM requires a minimum of 20 ohms impedance.
4. Connect the SIM to a 7-25 VDC power supply. A maximum of 30 mA is required. **Do not turn on the power supply yet.**
5. Connect the SIM to your computer's serial port using the 9-pin to 9-pin cable supplied with the SIM.

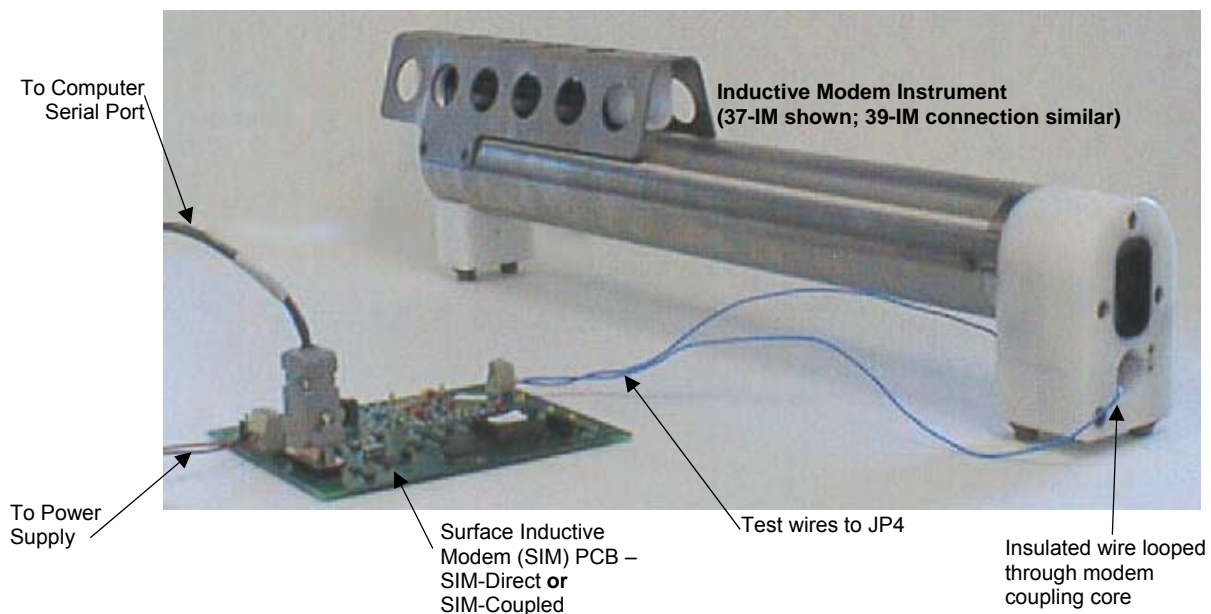

Test and Set SBE 39-IM ID Using SBE 39-IM with SIM

1. Double click on SeaTerm.exe. If this is the first time the program is used, the setup dialog box may appear:

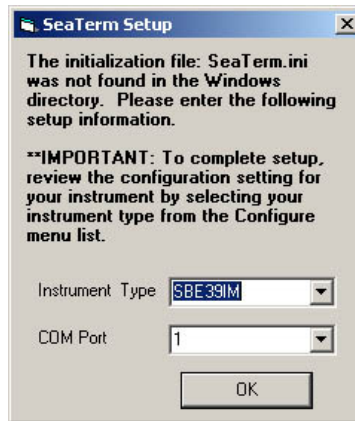

Note:
See SEATERM's Help files.

Select the instrument type (*SBE 39IM*) and the computer COM port for communication with the 39-IM. Click OK.

2. The main screen looks like this:

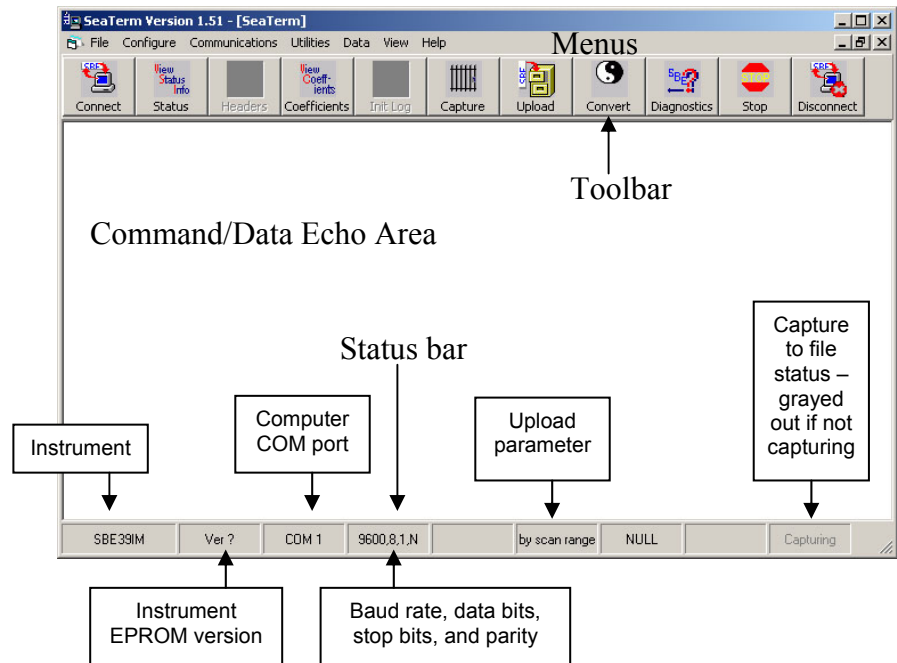

Note:
There is at least one way, and as many as three ways, to enter a command:

- Manually type a command in Command/Data Echo Area
- Use a menu to automatically generate a command
- Use a Toolbar button to automatically generate a command

Note:

Once the system is configured and connected (Steps 3 through 5 below), to update the Status bar:

- on the Toolbar, click Status; or
- from the Utilities menu, select Instrument Status.

SEATERM sends the status command, which displays in the Command/Data Echo Area, and updates the Status bar.

- **Menu** – Contains tasks and frequently executed instrument commands.
- **Toolbar** – Contains buttons for frequently executed tasks and instrument commands. All tasks and commands accessed through the Toolbar are also available in the Menu. To display or hide the Toolbar, select View Toolbar in the View menu. Grayed out Toolbar buttons are not applicable.
- **Command/Data Echo Area** – Echoes a command executed using a Menu or Toolbar button, as well as the instrument's response. Additionally, a command can be manually typed in this area, from the available commands for the instrument. Note that the instrument must be *awake* for it to respond to a command (use Connect on the Toolbar to wake up the instrument).
- **Status bar** – Provides status information. To display or hide the Status bar, select View Status bar in the View menu.

Following are the Toolbar buttons applicable to the 39-IM:

Toolbar Button	Description	Equivalent Command*
Connect	Re-establish communications by sending wakeup tone to all IM instruments on-line. Computer responds with S> prompt. IM instruments <i>go to sleep</i> after 2 minutes without communication from computer have elapsed.	PwrOn
Status	Display instrument setup and status (logging, number of samples in memory, etc.).	#iiDS
Coefficients	Display calibration coefficients.	#iiDC
Capture	Capture instrument responses on screen to file; may be useful for diagnostics. File has .cap extension. Press Capture again to turn off capture. Capture status displays in Status bar.	—
Upload	Upload data from 39-IM's memory, in format to allow post-processing by Plot39 or SBE Data Processing. Uploaded data has .asc extension. Before using Upload: <ul style="list-style-type: none"> • Configure upload and header parameters in Configure menu • If Autonomous Sampling: Send #iiStop to stop logging 	#iiDDb,e or DB,n,b,e (use Upload button if you will be processing data with Plot39 or SBE Data Processing)
Convert	Convert uploaded ASCII data to .cnv data, which can then be processed by SBE Data processing.	—
Diagnostics	Perform one or more diagnostic tests on 39-IM. Diagnostic test(s) accessed in this manner are non-destructive – they do not write over any existing instrument settings.	#iiDS, #iiDC, #iiTS, and #iiTSR
Stop	—	Not applicable to 39-IM
Disconnect	Free computer COM port used to communicate with 39-IM. COM port can then be used by another program.	—

*See *Command Descriptions* in Section 4: *Deploying and Operating SBE 39-IM*.

3. In the Configure menu, select **SBE 39IM**. The dialog box looks like this:

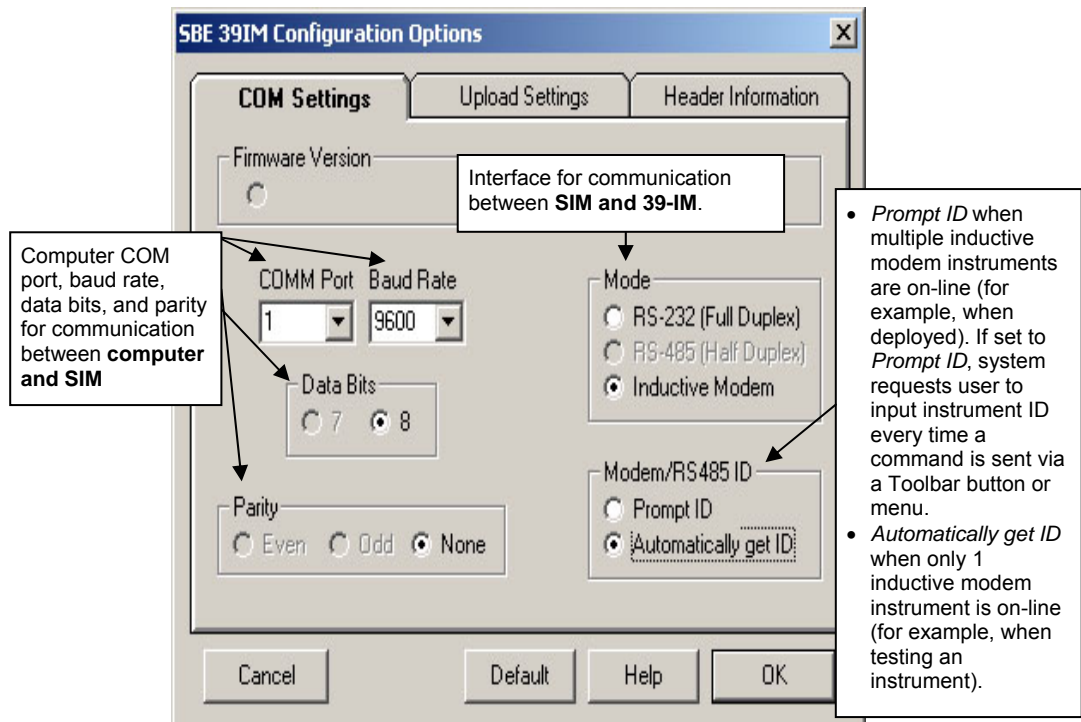

Notes:

- SEATERM's baud rate must be the same as the IMM or SIM baud rate. Baud is factory-set to 9600, but can be changed by the user (see *Command Descriptions* in *Section 4: Deploying and Operating SBE 39-IM*).
- When you click OK, SEATERM saves the Configuration Options settings to the SeaTerm.ini file in your Windows directory. SeaTerm.ini contains the last saved settings for **each** instrument. When you open SEATERM and select the desired instrument (SBE 39IM, 39, etc.) in the Configure menu, the Configuration Options dialog box shows the last saved settings for that instrument.
- When deploying on a mooring cable with multiple IM instruments, change **Modem /RS485 ID** to **Prompt ID** after testing is complete.

Note:

The display shows 37 because the SIM was originally developed for the SBE 37-IM MicroCAT.

Make the selections in the Configuration Options dialog box:

- **COMM Port:** COM 1 through COM 10, as applicable
- **Baud Rate:** 1200, 2400, 4800, or 9600 (see Configuration Sheet in manual)
- **Data Bits:** 8
- **Parity:** None
- **Mode:** Inductive Modem
- **Modem/RS-485 ID:** Automatically get ID

Click OK to save the settings.

4. Turn on the SIM power supply (if already on, turn it off and then on again). The display looks like this:

```
37 SURFACE MODEM V 3.0
S>
Sending wake up tone, wait 4 seconds
S>
```

This shows that correct communications between the computer and SIM has been established, and the SIM has sent the wake-up signal to the 39-IM.

If the system does not respond as shown above:

- Click Connect on the Toolbar.
- Verify the correct instrument (**SBE 39IM**) was selected in the Configure menu and the settings were entered correctly in the Configuration Options dialog box. Note that the baud rate is documented on the Configuration Sheet in the manual.
- Check cabling between the computer, SIM, and 39-IM.

5. Click Connect on the Toolbar. This allows the system to use the *Automatically get I.D.* feature when using the Toolbar keys or menus.

6. Confirm the 39-IM has responded to the wake-up signal by typing **ID?** and pressing the Enter key. The display looks like this:

```
id=01
```

where 01 is the number set at the factory or by the previous user. See the Configuration Sheet for the factory-set identification (ID) number. Note that the ID is stored in the 39-IM's EEPROM and can be changed so that multiple 39-IMs on a single mooring each have a unique ID.

Press the Enter key to get the S> prompt.

7. Display 39-IM status information by typing **#iiDS** (ii = 39-IM ID number) and pressing the Enter key. The display looks like this:

```
SBE 39-IM V 1.1 SERIAL NO. 9876 22 Jul 2008 15:01:39
battery voltage = 8.0
not logging: received stop command
sample interval = 10 seconds
samplenummer = 0, free = 2990824
SBE 39-IM configuration = temperature and pressure
transmit sample number
temperature = 9.64 deg C
```

8. Command the 39-IM to take a sample by typing **#iiTS** (ii = 39-IM ID number) and pressing the Enter key. The display looks like this (if 39-IM includes optional pressure sensor):

```
09876, 9.6404, 0.062, 22 Jul 2008, 16:30:43
```

where 09876 = 39-IM serial number
 9.6404 = temperature in degrees Celsius
 0.062 = pressure in dbars
 22 Jul 2008 = date
 16:30:43 = time

These numbers should be reasonable; i.e., room temperature, barometric pressure (gauge pressure), current date and time (factory-programmed to Pacific Daylight or Standard Time; can be changed by user).

Press the Enter key to get the S> prompt.

9. Each IM instrument on a mooring must have a unique ID for communicating with the IMM or SIM and computer:

- A. Set the 39-IM ID by typing ***ID=ii** (ii= user-assigned ID number) and pressing the Enter key.
- B. The computer responds by requesting verification, requiring you to again type ***ID=ii** and press the Enter key.
- C. Record the ID for future reference.
- D. Press the Enter key to get the S> prompt.
- E. Click Connect on the Toolbar. This allows the system to use the *Automatically get I.D.* feature when using Toolbar keys or menus.

10. Command the 39-IM to go to sleep (quiescent state) by typing **PwrOff** and pressing the Enter key.

The 39-IM is ready for programming and deployment.

Important! When testing and ID setting is complete for all the 39-IMs, reinstall the J5 jumper on the SIM PCB. The jumper must be installed for Normal Deployed operation.

Note:

The SIM and 39-IM have timeout algorithms designed to:

- restore control to the computer if an illegal command is sent
- conserve battery energy if too much time elapses between commands

If the system does not appear to respond, see *Timeout Descriptions* in *Section 4: Deploying and Operating SBE 39-IM* for details.

Note:

If more than one IM instrument is on-line when you set the ID, all IM instruments will be set to the same ID. The inductive modem receivers in IM instruments are very sensitive; two IM instruments that are side-by-side will take the same ID, even if one of them is not on the IM loop. **Therefore, separate IM instruments by at least 2 meters when setting IDs.**

Section 4: Deploying and Operating SBE 39-IM

This section provides instructions / discussions on:

- system operation
- example sets of operation commands for each operating mode
- detailed command descriptions
- data output formats
- deployment
- recovery
- uploading data
- processing data

Operation Description

The 39-IM's internal functions are supervised by two internal microcontrollers. The acquisition microcontroller supervises measurement acquisition, and setup and sampling functions. The communication microcontroller supervises communication between the 39-IM and IMM/SIM. These two microcontrollers allow for independent control of power usage by the communication and acquisition circuits. Acquisition consumes more power, but for shorter duration. Communication protocols take proportionately more time, but can be controlled separately and operate at lower power, thus maximizing battery life. This also prevents communication protocols from interfering with measurement acquisition timing.

Commands can be directed to the IMM or SIM (typically at the surface), the 39-IM's communication microcontroller (with a ! prefix), or the 39-IM's acquisition microcontroller (with a # prefix).

- An ID command prefix (**#ii** or **!ii**) is used to direct commands to a 39-IM with the same ID.
- A serial number command prefix (**#Sx:** or **!Sx:**) is used to direct commands to a 39-IM with the same serial number (serial number is set at the factory; serial number is 390xxxx, where 390 designates the 39-IM and xxxx is the four digit instrument serial number). Serial number addressing is useful if you have accidentally set identical IDs for multiple instruments, and do not realize the error until the instruments are deployed on the mooring.
- A Group command prefix (**#Gn:** or **!Gn:**) is used to direct commands to all instruments in a user-defined Group. For example, you can set up all 39-IMs to be in Group 1, all SBE 51s to be in Group 2, etc. Then, you can direct the appropriate commands to all instruments in the same Group.
- Global commands do not require a prefix and are recognized by all inductive modem instruments attached to the same inductive cable.

Note:

The SIM does not *know* that there will be no response from a group command (**#Gn:** or **!Gn:**), and will wait for a response before allowing you to enter the next command. If using the SIM (with RS-232 communication between the SIM and computer), press Esc and Enter after sending a group command to eliminate waiting before being able to send the next command.

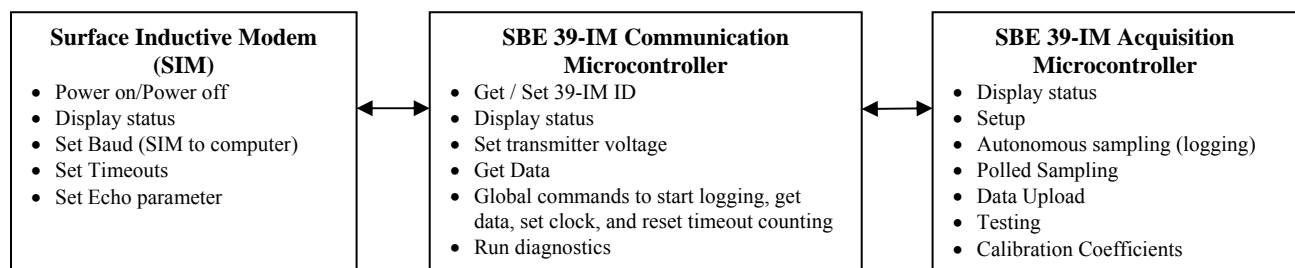

Note:

The following commands do not wake up the acquisition microcontroller: **!iiData**, **Dataii**, **ID?**, ***ID**, and these SIM commands: **DS**, **Baud=**, **DataNNMax=**, **RelayMax=**, **EchoOn**, **EchoOff**, **AutoPwrOn=**. All other commands wake up the acquisition microcontroller.

Each time a command is sent that wakes up the 39-IM's acquisition microcontroller:

1. The 39-IM responds to the transmitted command, and
2. The acquisition microcontroller goes back to sleep (quiescent state).

Timeout Descriptions

The IMM, SIM, and the 39-IM have timeout algorithms.

For **IMM timeouts**, see the IMM manual.

SIM timeouts restore control to the computer if no reply is received from the IM instrument (for example, upon sending an illegal command) within a specified length of time. This allows new commands to be sent. There are two user-programmable SIM timeouts that are applicable for use with the 39-IM:

- **DataNNMax=** timeout for **!iiData** and **Dataii** only. Default 1000 milliseconds.
- **RelayMax=** timeout for all other commands. Default 20 seconds.

When using RS-232 between the SIM and computer, control of the SIM can be re-established sooner than the timeout by pressing the Esc key and then the Enter key. When the **S>** prompt is displayed, new commands can be sent.

The 39-IM timeout powers down the 39-IM communication circuits if the 39-IM does not receive a command for two minutes, to prevent battery exhaustion. **To re-establish control, send PwrOn or click Connect on the Toolbar.**

Sampling Modes

The 39-IM's user-selectable sampling modes for obtaining data include:

- Polled Sampling
- Autonomous Sampling
- Combo Sampling
- Averaging Sampling

Commands can be used in various combinations and in one or more sampling modes to provide a high degree of operating flexibility. Review the operation of the sampling modes and the commands described in *Command Descriptions* before setting up your system.

Descriptions and examples of the sampling modes follow for a system with three 39-IMs (IDs 01, 02, and 03) on a mooring cable. Note that the 39-IM's response to each command is not shown in the examples.

Polled Sampling

On command, the 39-IM takes one sample of data and sends the data to the SIM. Storing of data in the 39-IM's FLASH memory is dependent on the particular command used.

Example: Polled Sampling (user input in bold)

Send wakeup tone to all IM instruments. Command each 39-IM to take a sample (do not store data in memory) and send converted data to IMM/SIM. Send power-off command.

(Click Connect on Toolbar to wake up all IM instruments on line.)

```
S>#01ts  
S>#02ts  
S>#03ts  
S>pwroff
```

Autonomous Sampling (Logging commands)

At pre-programmed intervals (**#iiInterval=**), the 39-IM wakes up, samples data and stores it in FLASH memory, and goes to sleep (enters quiescent state). The 39-IM does not automatically transmit data to the IMM/SIM while logging.

Logging is started with **#iiStartNow**, **#iiResumeLogging**, **#iiStartInterval**, **#iiGetAvgRestart**, **#iiGetLastRestart**, or **#iiStartLater**, or with a global command to all inductive modem instruments on-line (**GData**). Logging is stopped with **#iiStop**.

To synchronize data samples for each inductive modem instrument:

1. Set the sampling interval for each inductive modem instrument to the same value.
2. Send global commands to set the date and then time for all inductive modem instruments to the same value.
3. Start logging using **one** of the following methods:
 - Set the delayed logging start date and time for each inductive modem instrument to the same value, and then send **#iiStartLater**.
 - Start logging now using the global **GData** command.

Note:

See *Specifications in Section 2: Description of SBE 39-IM* for real-time clock specifications.

Note:

Use **#iiStop** to:

- stop logging
 - stop waiting to start logging (after **#iiStartLater** has been sent)
- Once **#iiStop** is sent, the 39-IM will accept all commands again.

The 39-IM has a *lockout* feature to prevent unintended interference with sampling. If the 39-IM is logging or is waiting to start logging (**#iiStartLater** has been sent, but logging hasn't started yet), only the following commands will be accepted:

- All IMM/SIM commands.
- These 39-IM Communication Microcontroller commands: **GData**, **StayOn**, **!iiData**, **Dataii**, **ID?**, **!iiDS**.
- These 39-IM Acquisition Microcontroller commands: **#iiDS**, **#iiDC**, **#iiSS**, **#iiDNx**, **#iiGetAvgRestart**, **#iiGetAvg**, **#iiGetLastRestart**, **#iiGetLast**, **#iiGetNew**, **#iiStop**.

Example: Autonomous Sampling (user input in bold)

Send wakeup tone to all IM instruments. Set date and time to 16 November 2005 12:00:00, using global commands. For each 39-IM: set sample number to 0 to overwrite previous data in memory, take samples every 10 sec, automatically start 17 November 2005 12:00:00. Verify setup. Send power-off after all parameters are entered - system automatically wakes up and powers down for each sample.

(Click Connect on Toolbar to wake up all IM instruments on line)

```
S>mmddy=111605
S>hhmmss=120000
S>#01samplenum=0
S>#01interval=10
S>#01startmmddy=111705
S>#01starthhmmss=120000
S>#01startlater
S>#01ds (to verify setup)
(Repeat #iisamplenum=0 through #iids for 39-IMs 02 and 03.)
S>pwroff
```

39-IMs automatically start logging at programmed date and time. When ready to upload all data to computer, wake up all 39-IMs, stop sampling, and upload data. Send power-off command.

(Click Connect on Toolbar to wake up all IM instruments on line.)

```
S>#01stop
(Click Upload on Toolbar – program leads you through screens to define data to be uploaded and where to store it.)
(Repeat #iistop through Upload for 39-IMs 02 and 03.)
S>pwroff
```

Combo Sampling

Combo Sampling combines Autonomous Sampling with the ability to periodically retrieve the last stored data sample from each 39-IM, to allow the user to look at some data without stopping the sampling. As in Autonomous Sampling, at pre-programmed intervals the 39-IM wakes up, samples data and stores it in its FLASH memory, and goes to sleep (enters quiescent state).

When desired, the user can globally request the last data sample from FLASH memory. Each 39-IM gets the data from the FLASH memory and holds the data in a buffer. The user can then request the data from the buffer of a particular 39-IM.

Example: Combo Sampling (user input in bold)

Send wakeup tone to all 39-IMs. Set date and time to 16 November 2005 12:00:00, using global commands. For each 39-IM: set **GData** command to get last sample and restart sampling in (**#iiInterval/2**) seconds, set sample number to 0 to overwrite previous data in memory, take samples every 10 sec, automatically start 17 November 2005 12:00:00. Verify setup. Send power-off after all parameters are entered – system automatically wakes up and powers down for each sample.

(Click Connect on Toolbar to wake up all IM instruments on line.)

```
S>mmddy=111605
S>hhmmss=120000
S>!01setgdatastr=getlastrestart
S>#01samplenum=0
S>#01interval=10
S>#01startmmddy=111705
S>#01starthhmmss=120000
S>#01startlater
S>#01ds (to verify setup)
(Repeat #iisamplenum=0 through #iids for 39-IMs 02 and 03.)
S>pwroff
```

39-IMs automatically start logging at programmed date and time. Send global command to look at data from last sample to check results. Then send command to each 39-IM to transmit last sample. Send power-off.

(Click Connect on Toolbar to wake up all IM instruments on line.)

```
S>gdata
S>!01data
S>!02data
S>!03data
S>pwroff
```

When ready to upload all data to computer, wake up all 39-IMs, stop sampling, and upload data. Send power-off command.

(Click Connect on Toolbar to wake up all IM instruments on line.)

```
S>#01stop
```

(Click Upload on Toolbar – program leads you through screens to define data to be uploaded and where to store it.)

(Repeat **#iistop** through Upload for 39-IMs 02 and 03.)

```
S>pwroff
```

Note:

In the example, when the communication microcontroller receives the global **GData**, it sends **GetLastRestart** (as defined by **!iiSetGDataStr=**) to the acquisition microcontroller. **GetLastRestart** resets the logging time base; the next sample is taken at (**#iiInterval/2**) after receipt of **GetLastRestart**.

Averaging Sampling

Averaging Sampling combines Autonomous Sampling with the ability to periodically retrieve averaged data from each 39-IM, to allow the user to look at averaged data without stopping sampling. As in Autonomous Sampling, at pre-programmed intervals the 39-IM wakes up, samples data and stores it in its FLASH memory, and goes to sleep (enters quiescent state). As the 39-IM is sampling, it automatically adds the data values (T and optional P) for each sample to an *averaging section* in the FLASH memory, and keeps track of the number of samples since the last averaging request.

Note:

In the example, when the communication microcontroller receives the global **GData**, it sends **GetAvgRestart** to the acquisition microcontroller. **GetAvgRestart** (as defined by **!iiSetGDataStr=**) resets the logging time base; the next sample is taken at (**#iiInterval/2**) after receipt of **GetAvgRestart**.

When desired, the user can globally request the average of the data sampled since the last request. Each 39-IM gets the data from the averaging section in FLASH, divides the sums by the number of samples, holds the averaged data in a buffer, and resets the averaging section to begin a new average. The user can then request the averaged data from the buffer of a particular 39-IM.

Example: Averaging Sampling (user input in bold)

Send wakeup tone to all 39-IMs. Set date and time to 16 November 2005 12:00:00, using global commands. For each 39-IM: set **GData** command to get average and restart sampling in (**#iiInterval/2**) seconds, set sample number to 0 to overwrite previous data in memory, take samples every 10 sec, automatically start 17 November 2005 12:00:00. Verify setup. Send power-off after all parameters are entered - system automatically wakes up and powers down for each sample.

(Click Connect on Toolbar to wake up all IM instruments on line.)

```
S>mmddy=111605
S>hhmmss=120000
S>!01setgdatastr=getavgrestart
S>#01samplenum=0
S>#01interval=10
S>#01startmmddy=111705
S>#01starthhmmss=120000
S>#01startlater
S>#01ds (to verify setup)
(Repeat #iisamplenum=0 through #iids for 39-IMs 02 and 03.)
S>pwroff
```

39-IMs automatically start logging at programmed date and time. Send global command to calculate averaged data and start a new average for each 39-IM. Then send command to each 39-IM to transmit averaged data. Send power-off.

(Click Connect on Toolbar to wake up all IM instruments on line.)

```
S>gdata
S>!01data
S>!02data
S>!03data
S>pwroff
```

When ready to upload all data to computer, wake up all 39-IMs, stop sampling, and upload data. Send power-off.

(Click Connect on Toolbar to wake up all IM instruments on line.)

```
S>#01stop
(Click Upload on Toolbar – program leads you through screens to define data to be uploaded and where to store it.)
(Repeat #iistop through Upload for 39-IMs 02 and 03.)
S>pwroff
```

Command Descriptions

This section describes commands and provides sample outputs. See *Appendix III: Command Summary* for a summarized command list.

When entering commands:

- Input commands to the 39-IM in upper or lower case letters and register commands by pressing the Enter key.
- The 39-IM sends `? CMD` if an invalid command is entered.
- If the 39-IM is taking a sample when a command is received, it sends:

```
<!--SBE39IM ACQ CONTROLLER BUSY wait a few
seconds and repeat command-->
<Busy/>
```
- If the system does not return an `S>` prompt after executing a command, press the Enter key to get the `S>` prompt.
- If a new command is not received within two minutes after the completion of a command, the 39-IM returns to the quiescent (sleep) state to prevent exhaustion of its batteries.
- If in quiescent state, re-establish communications by clicking **Connect** on the Toolbar or sending **PwrOn** to get an `S>` prompt.

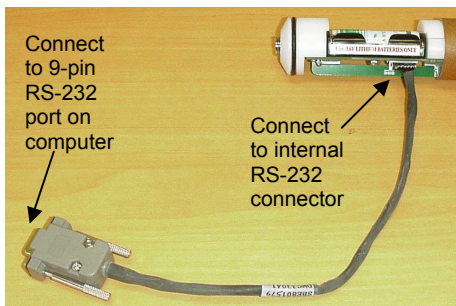

RS-232 cable supplied by Sea-Bird

- If desired, you can set up the 39-IM using the internal RS-232 connector (see *Battery Replacement* in *Section 5: Routine Maintenance and Calibration* to access the connector). If setting up in this way, omit the `#ii` prefix in the Acquisition Microcontroller commands.
- If a command is received through the inductive modem while the internal RS-232 connector is plugged in, the 39-IM sends:

```
<!--SBE39IM ACQ CONTROLLER SERVICING PC SERIAL
PORT DPSK DISABLED-->
<Busy/>
```
- If using the 39-IM with an **Inductive Modem Module (IMM)**, see the IMM manual for details on IMM commands.
- If using the 39-IM with a **Surface Inductive Modem (SIM)**, the SIM commands are included in this manual.
- When you send a group command (`#Gn:` or `!Gn:`), the IMM/SIM connected to the controller will not get a response from the instruments, because only one instrument can communicate at a time (the inductive modem telemetry is half-duplex). The IMM, a newer interface, has been programmed to not wait for a response from a group command. However, the SIM will *listen* for a response until the user-programmable timeout has passed. If using a SIM with an RS-232 interface to the computer, press the Esc key and then the Enter key to avoid waiting for the timeout.

SIM Commands

SIM commands are directed to the Surface Inductive Modem, to set it up for operation with the 39-IM.

PwrOn Send wakeup tone to **all** IM instruments on-line. Equivalent to Connect on Toolbar.

PwrOff Send power-off command to **all** IM instruments on-line. Main power turned off and IM instruments placed in quiescent (sleep) state. Data logging and memory retention not affected.

Note:

The status display shows 37 because the SIM was originally developed for the SBE 37-IM MicroCAT.

DS Display SIM firmware version and status. Example includes command used to modify parameter [in parentheses].

Example: (user input in bold)

S>**ds**

SBE 37 SURFACE MODEM V 3.0

wait time for dataNN response = 1000 msec

wait time for relay command response = 20 seconds

binary relay character timeout = 1000 msec

echo = yes

execute pwrn command on powerup = yes

[DataNNMax=]

[RelayMax=]

[not applicable to 39-IM]

[EchoOn or EchoOff]

[AutoPwrOn=]

Note:

The SIM's baud rate (set with **Baud=**) must be the same as SEATERM's baud rate (set in the Configure menu).

Baud=x x= baud rate between SIM and computer / controller (1200, 2400, 4800, or 9600). Default 9600.

DataNNMax=x x= timeout (0-32767 milliseconds; SIM rounds down to nearest 50 milliseconds) that applies to **!iiData** and **Dataii** only. If no reply received within **DataNNMax**, control returned to computer and other commands can be sent. Default 1000 milliseconds.

RelayMax=x x= timeout (0-3276 seconds) that applies to all other commands. If no reply received within **RelayMax**, control returned to computer and other commands can be sent. Default 20 seconds.

EchoOn Echo characters received from computer (default) - computer monitor will show entered commands as you type.

EchoOff Do not echo characters received from computer - computer monitor will not show entered commands as you type.

Note:

AutoPwrOn=N is typically used only with a *Tone Detect* board system for an SBE 44 Underwater Inductive Modem.

AutoPwrOn=x x=Y (default): Automatically send **PwrOn** to IM instruments on-line when power applied to SIM. This wakes up all IM instruments on-line.

x=N: Do not send **PwrOn** when power applied to SIM.

SBE 39-IM Communication Microcontroller Commands

Communication microcontroller commands are typically preceded by one of the following prefixes:

- **!ii** (ii = 39-IM ID, 0 – 99) [*as shown in the command listings below*], for transmission to the 39-IM with the indicated ID.
- **!Sx:** (x = serial number of 39-IM) in place of **!ii**, for transmission to the SBE 39-IM with the indicated serial number.
- **!Gn:** (n = group number of 39-IM) in place of **!ii**, for transmission to all 39-IMs in the indicated group. Only the following Communication Microcontroller commands can be addressed by group: **SetFullPwrTx**, **SetLowPwrTx**, **SetGDataStr=**, **ResetEC**, **ResetEventCounters**, **StayOn**, **SetGroupNumber**, **GData**.

Note:

The SIM does not *know* that there will be no response from a group command, and will wait for a response before allowing you to enter the next command. If using the SIM (with RS-232 communication between the SIM and computer), press Esc and Enter after sending a group command to eliminate waiting before being able to send the next command.

Communication Microcontroller Status Commands

!iids

Display communication microcontroller status and setup parameters.

List below includes, where applicable, command used to modify parameter.

- firmware version
- date firmware was compiled
- communication microcontroller transmitter voltage [**!iiSetLowPwrTx** or **!iiSetFullPwrTx**]
- command to be sent to 39-IM when **GData** is sent [**!iiSetGDataStr=**]
- diagnostic information - number of events (power-up, low battery, invalid commands, errors, etc.) since event counter was last reset

Example: For 39-IM with ID=01 (user input in bold, command used to modify parameter in parentheses).

```
S>!01ds
SBE39IM Controller Version 1.98
Compiled Feb 4 2008
Transmitter set to full power                [!iiSetLowPwrTx or !iiSetFullPwrTx]
GDATA String=GETAVGRESTART                 [!iiSetGDataStr=]
0 Events
<Executed/>
```

!iiGetSD

Display status data.

List below includes, where applicable, command used to modify parameter:

- Device type, Serial number
- Number of events in event counter [**!iiResetEC**]
- Main battery voltage

Example: Send **GetSD** to 39-IM with ID=02 (user input in bold)

```
S>!02getsd
<StatusData
DeviceType='SBE39' SerialNumber='3900000'>
<EventSummary numEvents='3' />                [!iiResetEC to reset to 0]
<Power><MainBatteryVoltage>6.9</MainBatteryVoltage></Power>
</StatusData>
<Executed/>
```

Communication Microcontroller Status Commands *continued***!iiGetCD**

Display configuration data.
List below includes, where applicable,
command used to modify parameter:

- Device type, Serial number
- Host instrument [**!iiSetHostID=**]
- GData string [**!iiSetGDataStr=**]
- ID number [***ID=**]
- Group number [**!iiSetGroupNumber=**]
- communication microcontroller transmitter voltage [**!iiSetLowPwrTx** or **!iiSetFullPwrTx**]

Example: Send **GetCD** to 39-IM with ID=02 (user input in bold)

```
S>!02getcd
<ConfigurationData
DeviceType='SBE39' SerialNumber='3900000'>
<HostID>SBE39</HostID>                                [!iiSetHostID=]
<GDataString>getavgrestart</GDataString>              [!iiSetGDataStr=]
<ConfigSettings
DeviceID='2'                                           [*ID=]
GroupNum='4'                                           [!iiSetGroupNumber=]
TXPower='LOW' />                                     [!iiSetLowPwrTx or !iiSetFullPwrTx]
</ConfigurationData>
<Executed/>
```

!iiGetHD

Display hardware data (factory set).

- Device type, Serial number
- Manufacturer
- Hardware top PCB version
- Hardware bottom PCB version
- Manufacture date
- Firmware version
- Firmware date

Example: Send **GetHD** to 39-IM with ID=02 (user input in bold)

```
S>!02gethd
<HardwareData
DeviceType='SBE39' SerialNumber='3900000'>
<Manufacturer>Sea-Bird Electronics, Inc</Manufacturer>
<DeviceVersion>SBE39IM</DeviceVersion>
<HardwareVersion>41443E</HardwareVersion>
<HardwareVersion>Digital PCB Type 3 (10349B)</HardwareVersion>
<FirmwareVersion>SBE39IM Controller Version 1.98</FirmwareVersion>
<FirmwareDate>Feb 4 2008</FirmwareDate>
</HardwareData>
<Executed/>
```

!iiGetHostID

Display host ID.

Example: Send **GetHostID** to 39-IM with ID=02 (user input in bold)

```
S>!02gethostid
<HostID>SBE39IM SN3284</HostID>                       [!iiSetHostID=]
<Executed/>
```

Notes:

- **If more than one IM instrument is on-line when you set the ID, all IM instruments will be set to the same ID.** The inductive modem receivers in IM instruments are very sensitive; two IM instruments that are side-by-side will take the same ID, even if one of them is not on the IM loop. **Therefore, separate IM instruments by at least 2 meters when setting IDs.**
- When setting the ID, it can be sent as one or two digits (for example, ***ID=02** and ***ID=2** are equivalent).

Communications Microcontroller ID Commands

Only one IM instrument can be on line when sending these commands.

ID?

Display IM instrument ID (0-99).

***ID=ii**

Set IM instrument ID to ii (ii= 0-99). Must be sent twice, because verification requested. **If more than one IM instrument is on-line, all IM instruments will be set to same ID.**

Example: (user input in bold)

S>***id=02**

Repeat Command to set ID to 02

Do not repeat if more than one IM device is coupled to the loop

S>***id=02**

ID = 02

!iiSetDeviceID=nn

nn= new instrument ID
(ii= old instrument ID).

Example: Reset device ID from 01 to 02 (user input in bold)

S>**!01setdeviceid=02**

<Executed/>

!Sx:SetDeviceID=nn

nn= new instrument ID
(x= instrument serial number).

Example: Reset device ID to 02 for 39-IM with serial number 3901234 (user input in bold)

S>**!s3901234:setdeviceid=02**

<Executed/>

!iiSetHostID=x

x= host ID, 4 – 64 character string.

Example: (user input in bold)

S>**!01sethostid=SBE39IM SN3284**

<Executed/>

Communications Microcontroller Setup Commands

!iiSetLowPwrTx Set 39-IM's transmitter voltage to low power; power saving setting. This command can also be sent as a group command (**!Gn:** in place of **!ii**).

!iiSetFullPwrTx Set 39-IM's transmitter voltage to full power; maximum signal strength. This command can also be sent as a group command (**!Gn:** in place of **!ii**).

Note:

When sending a logging command to a particular IM instrument on line, it is preceded by **#ii**. However, the string sent with **!iiSetGDataStr=** does not include the **#ii**, because the communication microcontroller can only communicate with the acquisition microcontroller in the same 39-IM and does not need to know the ID.

!iiSetGDataStr=x

x= string (2 to 16 characters) sent to 39-IM acquisition microcontroller when **GData** command is received by communication microcontroller. String is one of the following logging commands: **GetAvgRestart** (default), **StartNow**, **ResumeLogging**, **StartInterval**, **GetAvg**, **GetLastRestart**, **GetLast**, or **GetNew**. This command can also be sent as a group command (**!Gn:** in place of **!ii**).

Example: For 39-IM with ID=01 (user input in bold).

```
S>>!01setgdatastr=getavg
<Executed/>
```

When **GData** is sent to all IM instruments on line, communication microcontroller for 39-IM with ID=01 will send **GetAvg** to 39-IM's acquisition microcontroller. See *Acquisition Microcontroller Commands* below for description of **#iiGetAvg**.

!iiSetGroupNumber=x

x= 39-IM group number. Group 0 is pre-defined as group of all instruments. An instrument cannot belong to more than one group in addition to group 0. This command can also be sent as a group command (**!Gn:** in place of **!ii**).

!iiStayOn

Command 39-IM to reset counting for 2-minute timeout, preventing 39-IM from going to sleep. This command can also be sent as a group command (**!Gn:** in place of **!ii**).

Global Commands

Global commands are not preceded by any prefix, and are directed to all IM instruments on line.

Notes:

- **DDMMYY=** and **MMDDYY=** are equivalent. Either can be used to set the date.
- If the 39-IM batteries have been removed, the date and then time must be reset.
- **Always set date and then time.** If a new date is entered but not a new time, the new date will not be saved. If a new time is entered without first entering a new date, the date will reset to the last date it was set for with **MMDDYY=** or **DDMMYY=**.

MMDDYY=mmddy

Set real-time clock month, day, and year for **all** IM instruments on-line. Must be followed by **HHMMSS=** to set time.

DDMMYY=ddmmyy

Set real-time clock day, month, and year for **all** IM instruments on-line. Must be followed by **HHMMSS=** to set time.

HHMMSS=hhmmss

Set real-time clock hour, minute, and second for **all** IM instruments on-line.

GData

Simultaneously command **all** IM instrument communication microcontrollers to send command string defined by **!iiSetGDataStr=** to their acquisition microcontrollers. Acquisition microcontrollers transmit data (last sample or average, depending on command string) to communication microcontrollers, which hold data in buffer until receiving **!iiData**, **Dataii**, or **!iiGetReply**.

Note:

GData can be used to simultaneously start logging in all IM instruments on-line.

StayOn

Command **all** IM instruments on-line to reset counting for 2-minute timeout, preventing individual IM instruments from going to sleep while you are communicating with another IM instrument on mooring.

Communication Microcontroller Get Data Commands

!iiGData

Command 39-IM communication microcontroller to send command string defined by **!iiSetGDataStr=** to acquisition microcontrollers. Acquisition microcontroller transmits data (last sample or average, depending on command string) to communication microcontroller, which holds data in buffer until receiving **!iiData**, **Dataii**, or **!iiGetReply**. This command can also be sent as a group command (**!Gn:** in place of **!ii**).

```
S>!01gdata
<Executing>
<Executed/>
```

!iiData

Get data obtained with **GData** from buffer in IM instrument with ID = ii. If there is no data in buffer, 39-IM returns 01, XX Value Not Initialized.

Dataii

Same as **!iiData**. Provided for compatibility with older inductive modem instruments that do not include **!iiData** in their command set.

```
S>!01data      (or data01)
01, 03284, -99.0000, 12 Apr 2006, 13:49:14,      5, 1
```

!iiGetReply

Same as **!iiData**. Provided for compatibility with Inductive Modem Module (IMM) in place of SIM. If there is no data in buffer, 39-IM returns XX Value Not Initialized

```
S>!01getreply
<GDataReply> 03284, -99.0000, 22 Jul 2008, 13:49:14,      5, 1
</GDataReply>
<Executed/>
```

Communication Microcontroller Diagnostics Commands

!iiEchoIMx x= string (24 characters maximum, letter and numbers only) to be echoed back to IMM/SIM.

Example: For 39-IM with ID=01 (user input in bold).

```
S>!01echoim123456789abcdefg
ECHOIM123456789abcdefg <Executed/>
```

!iiTxTest Test line conditions. Test includes:

- 10 seconds of silence
- Transmission of upper case letter *U* 250 times
- Transmission of upper case letter *U* 250 times, with varied time intervals between each letter

!iiTestCableCoupler Test cable coupler in 39-IM.

!iiGetEventCounters Transmit list of *events* and number of times they occurred. Events can be unexpected conditions which should be interpreted as errors as well as device power-up, invalid commands, or low-battery conditions.

Example: For 39-IM with ID=01 (user input in bold).

```
S>!01geteventcounters
0 Events
Event [0] = 0
Event [1] = 0
. . .
Event [17] = 0
Event [18] = 0
```

!iiGetEC Equivalent to
!iiGetEventCounters.

!iiResetEventCounters Clear event counters to 0. This command can also be sent as a group command (**!Gn:** in place of **!ii**).

Example: For 39-IM with ID=01 (user input in bold).

```
S>!01reseteventcounters
<!--Event Count Reset-->
<Executed/>
```

!iiResetEC Equivalent to **!iiResetEventCounters.**
This command can also be sent as a group command (**!Gn:** in place of **!ii**).

SBE 39-IM Acquisition Microcontroller Commands

Note:

The SIM does not *know* that there will be no response from a group command, and will wait for a response before allowing you to enter the next command. If using the SIM (with RS-232 communication between the SIM and computer), press Esc and Enter after sending a group command to eliminate waiting before being able to send the next command.

When using inductive modem telemetry, Acquisition Microcontroller commands are preceded by one of the following prefixes:

- **#ii** (ii = 39-IM ID, 0 – 99) [*as shown in the command listings below*], for transmission to the 39-IM with the indicated ID.
- **#Sx**: (x = serial number of 39-IM) in place of **#ii**, for transmission to the 39-IM with the indicated serial number.
- **#Gn**: (n = group number of 39-IM) in place of **#ii**, for transmission to all 39-IMs in the indicated group. All acquisition microcontroller commands can be addressed to a group.

When using RS-232 telemetry (connecting directly to the 39-IM's internal RS-232 serial connector), omit the **#ii** prefix shown in the command listings below.

Acquisition Microcontroller Status Command

#iDS

Display status and setup parameters.
Equivalent to Status on Toolbar.

List below includes, where applicable, command used to modify parameter.

- firmware version, serial number, date and time [**#iiDateTime=**, or equivalent global commands; date format set by **#iiFormat=**]
- remaining battery voltage
- sampling status (logging not started, logging data, not logging: waiting to start at ... , not logging: received stop command, not logging: low battery, or unknown status)
- sample interval time [**#iiInterval=**]
- number of samples in memory and available sample space in memory
- configuration (temperature only or temperature with pressure)
- transmit sample number with **!iiData**, **Dataii**, or **!iiGetReply** output? [**#iiTxSampleNum=**]
- current temperature

Example: For 39-IM with ID=01 (user input in bold, command used to modify parameter in parentheses).

S>**#01ds**

SBE 39-IM V 1.1 SERIAL NO. 9876 22 Jul 2008 15:01:39

[**#iiDateTime=**, **#iiFormat=**]

battery voltage = 8.0

not logging: received stop command

sample interval = 10 seconds

[**#iiInterval=**]

sample number = 0, free = 2990824

SBE 39-IM configuration = temperature and pressure

transmit sample number

[**#iiTxSampleNum=**]

temperature = 9.64 deg C

Acquisition Microcontroller Setup Commands

Notes:

- **#iiDateTime=** is equivalent to sending **#iiDDMMYY=** (or **#iiMMDDYY=**) and **#iiHHMMSS=**.
- **#iiDDMMYY=** and **#iiMMDDYY=** are equivalent.
- **If using #iiDDMMYY=** (or **#iiMMDDYY=**) and **#iiHHMMSS=**, **always set date and then time.** If a new date is entered but not a new time, the new date will not be saved. If a new time is entered without first entering a new date, the date will reset to the last date it was set for with **#iiMMDDYY=** or **#iiDDMMYY=**.
- If the batteries have been removed, date and time must be reset.
- If the 39-IM is logging or waiting to start logging (**#iiStartLater** has been sent), it will not allow the user to reset date or time.

#iiDateTime=mmddyymmss Set real-time clock month, day, year, hour, minute, second. If you enter a date before January 1, 2000 or after January 1, 2100, 39-IM resets date to January 1, 2000.

Example: Set current date and time for 39-IM with ID=01 to 10 July 2008 12:23:59 (user input in bold).

```
S>#01datetime=07102008122358
```

#iiMMDDYY=mmddy Set real-time clock month, day, year. Must be followed by **#iiHHMMSS=** to set time.

#iiDDMMYY=ddmmy Set real-time clock day, month, year. Must be followed by **#iiHHMMSS=** to set time.

#iiHHMMSS=hhmmss Set real-time clock hour, minute, second.

Example: Set current date and time for 39-IM with ID=01 to 16 July 2008 12:00:00 (user input in bold).

```
S>#01mmddy=071608
```

```
S>#01hhmmss=120000
```

or

```
S>#01ddmmy=160708
```

```
S>#01hhmmss=120000
```

Note:

#iiTxSampleNum=Y could be used to verify that logging is occurring at the correct rate. For example, while logging:

1. Send **GData** and **!iiData**.
2. After some interval, send **GData** and **!iiData** again. Compare change in output sample numbers to expected change based on **#iiInterval=**.

#iiTxSampleNum=x

x=Y: Output six-character sample number (number of samples in memory at time sample was taken) with data from **!iiData**, **Dataii**, or **!iiGetReply**.

x=N: Do not output sample number.

Note:

See *Data Output Formats*.

#iiFormat=x

x=0 or **1** (default): Date format for converted data dd mmm yyyy.

x=2: Date format for converted data mm-dd-yyyy.

#iiQS

Only accepted in Serial mode (communicating through internal RS-232 serial connector).

Place 39-IM in quiescent (sleep) state. Main power is turned off. Data logging and memory retention are not affected.

Acquisition Microcontroller Autonomous Sampling (Logging) Commands**Note:**

If the 39-IM is logging data and the battery voltage is less than 5.8 volts for ten consecutive scans, the 39-IM halts logging and sets the logging status to low battery.

Autonomous sampling commands direct the 39-IM to sample data at pre-programmed intervals and store the data in its FLASH memory.

#iiInterval=x

x= interval (10 – 30000 seconds) between samples. When commanded to start sampling (with **#iiStartNow**, **#iiResumeLogging**, **#iiStartInterval**, **#iiStartLater**, **#iiGetAvgRestart**, or **#iiGetLastRestart** or global **GData**), 39-IM takes a sample, stores data in FLASH memory, and powers down every **#iiInterval** seconds.

Notes:

- **#iiInitLogging** and **#iiSampleNum=0** have identical effects. Use either command to initialize logging.
- Initializing logging sets sample number to 0 *internally*. However, for data output, the first sample number is 1.
- **Do not send #iiInitLogging or #iiSampleNum=0 until all data has been uploaded.** These commands do not delete data; they just reset the data pointer. **If you accidentally send one of these commands before uploading**, see *Memory* in *Appendix I: Functional Description* for recovery of the data.

#iiInitLogging

Initialize logging – after all previous data has been uploaded from 39-IM, initialize logging before starting to log again to make entire memory available for recording. Command sets sample number (**#iiSampleNum=**) to 0 internally. If this is not set to 0, data will be stored after last recorded sample.

#iiSampleNum=x

x= sample number for first sample when logging begins. After all previous data has been uploaded from 39-IM, set to 0 before starting to log to make entire memory available for recording. If not set to 0, data will be stored after last recorded sample.

#iiStartNow

Start logging. Logging starts **10 seconds** after command is received. Data is stored in FLASH memory.

Example: #iiInterval=360 (6 minutes)

Hr	min	sec	
00	00	00	#iiStartNow received
00	00	10	Sample
00	06	10	Sample
00	12	10	Sample
...			

#iiResumeLogging

Start logging. Logging starts **#iiInterval** seconds after command is received. Data is stored in FLASH memory.

Example: #iiInterval=360 (6 minutes)

Hr	min	sec	
00	00	00	#iiResumeLogging received
00	06	00	Sample
00	12	00	Sample
...			

#iiStartInterval

Same as **#iiResumeLogging**.

Acquisition Microcontroller Autonomous Sampling (Logging) Commands (continued)

Notes:

- **#iiStartDateTime=** is equivalent to sending **#iiStartDDMMYY=** (or **#iiStartMMDDYY=**) and **#iiStartHHMMSS=**.
- **#iiStartDDMMYY=** and **#iiStartMMDDYY=** are equivalent.

#iiStartDateTime=mmddyyhhmmss	Set delayed logging start month, day, year, hour, minute, second.
#iiStartMMDDYY=mmddyy	Set delayed logging start month, day, and year. Must be followed by #iiStartHHMMSS= to set delayed start time.
#iiStartDDMMYY=ddmmyy	Set delayed logging start day, month, and year. Must be followed by #iiStartHHMMSS= to set delayed start time.
#iiStartHHMMSS=hhmmss	Set delayed logging start hour, minute, and second.
#iiStartLater	Start logging at time set with delayed start date and time commands. Data is stored in FLASH memory.

Notes:

- After receiving **#iiStartLater**, the 39-IM displays not logging: waiting to start in reply to **#iiDS**. Once logging has started, the **#iiDS** reply shows logging data.
- If the delayed start time has already passed when **#iiStartLater** is received, the 39-IM executes **#iiStartNow**.

Example: 39-IM with ID=01 to start logging on 20 November 2008 12:00:00 (user input in bold).

```
S>#01startmmddyy=112008
S>#01starthhmmss=120000
S>#01startlater
or
S>#01startddmmyy=201108
S>#01starthhmmss=120000
S>#01startlater
```

#iiGetAvgRestart	Get and transmit average data, (re)start logging in (#iiInterval / 2) seconds, and start next averaging cycle.
-------------------------	---

Example: **#iiInterval=360** (6 minutes)

```
Hr  min  sec
00  00  00  #iiStartNow received
00  00  10  Sample
00  06  10  Sample
00  08  00  #iiGetAvgRestart received (average 2 data sets)
00  11  00  Sample at #iiInterval/2 from when #iiGetAvgRestart received
00  17  00  Sample
00  23  00  Sample
...
```

#iiGetAvg	Get and transmit average data and start next averaging cycle. Unlike #iiGetAvgRestart , this command does not reset logging time base.
------------------	--

Example: **#iiInterval=360** (6 minutes)

```
Hr  min  sec
00  00  00  #iiStartNow received
00  00  10  Sample
00  06  10  Sample
00  08  00  #iiGetAvg received (average 2 data sets)
00  12  10  Sample at #iiInterval from when last sample taken
00  18  10  Sample
00  24  10  Sample
...
```

Acquisition Microcontroller Autonomous Sampling (Logging) Commands (continued)

#iiGetLastRestart Get and transmit **last** data from FLASH memory, and (re)start logging in (**#iiInterval** / 2) seconds.

Example: #iiInterval=360 (6 minutes)

Hr	min	sec	
00	00	00	#iiStartNow received
00	00	10	Sample
00	06	10	Sample
00	08	00	#iiGetLastRestart received (send last sample)
00	11	00	Sample at #iiInterval/2 from when #iiGetLastRestart received
00	17	00	Sample
00	23	00	Sample
...			

#iiGetLast Get and transmit **last** data from FLASH memory. Unlike **#iiGetLastRestart**, this command does not reset logging time base.

Example: #iiInterval=360 (6 minutes)

Hr	min	sec	
00	00	00	#iiStartNow received
00	00	10	Sample
00	06	10	Sample
00	08	00	#iiGetLast received (send last sample)
00	12	10	Sample at #iiInterval from when last sample taken
00	18	10	Sample
00	24	10	Sample
...			

Note:

#iiGetNew can only be sent while logging, and does not interfere with logging.

#iiGetNew Get (take) and transmit new sample. Data is **not** stored in FLASH memory.

Note:

You may need to send **#iiStop** several times to get the 39-IM to respond. This is most likely to occur if sampling with a small **#iiInterval=**.

#iiStop Stop logging or stop waiting to start logging (if **#iiStartLater** was sent but logging has not begun yet). Press Connect on Toolbar to get S> prompt before entering **#iiStop**. **#iiStop** must be sent before uploading data.

Acquisition Microcontroller Polled Sampling Commands

These commands are used by an external controller to request a sample from the 39-IM.

Note:

The 39-IM has a buffer that stores the most recent data sample. Unlike data in the FLASH memory, data in the buffer is erased upon removal or failure of the batteries.

#iTS	Take sample and transmit converted data. Data is not stored in FLASH memory.
#iTSTR	Take sample and transmit raw data. Data is not stored in FLASH memory.
#iTSS	Take sample, store in FLASH memory , and transmit converted data.
#iSLT	Transmit converted data from last sample from buffer, and then take new sample. Data is not stored in FLASH memory.
#iSLTR	Transmit raw data from last sample from buffer, and then take new sample. Data is not stored in FLASH memory.
#iSL	Transmit converted data from last sample from buffer.

Acquisition Microcontroller Data Upload Commands

Upload data using one of these telemetry methods:

Note:

The uploaded data format is the same, regardless of the choice of upload telemetry (inductive modem or RS-232) and type (ASCII or binary).

- **RS-232 (serial mode)** - Much faster upload is available in serial mode; however, you must open the 39-IM housing to access the internal RS-232 serial connector. The RS-232 telemetry allows ASCII or binary upload; binary upload is inherently twice as fast as ASCII upload. Additionally, the RS-232 telemetry can upload in binary at up to 115,200 baud.
- **Inductive modem** – Data can be uploaded in ASCII while the 39-IM is deployed, or is wired in the lab as shown in *Test Setup* in *Section 3: Preparing SBE 39-IM for Deployment*. Upload speed is limited by the baud rate between the 39-IM and IMM/SIM, which is 1200 baud. We recommend uploading with IM telemetry only if you are interested in looking at a small amount of data or need to upload the data without recovering the instrument.

ASCII Upload:

ASCII upload is available when the 39-IM is in Serial Mode (i.e., cable is connected to the 39-IM internal RS-232 connector instead of communicating through the IMM/SIM) or using the inductive modem telemetry.

#iiDDb,e

Upload data from scan **b** to **e**. First scan is number 1. If **#iiDDb** is sent, only scan **b** is uploaded. If **#iiDD** is sent, all scans in memory are uploaded. **Send #iiSTOP to stop logging before sending #iiDDb,e.**

Notes:

- **Use Upload on the Toolbar or Upload Data in the Data menu to upload data that will be processed by Plot39 or SBE Data Processing;** SEATERM checks the setting on the Upload Settings tab in the Configuration dialog box to determine whether to upload in ASCII or binary format. Manually entering **#iiDDb,e**, **#iiDNx**, or **DB,n,b,e** does not produce data with the required header information for processing by Plot39 or SBE Data Processing.
- Before manually entering a data upload command, click Capture on the Toolbar to save data to a file.
- See *Data Output Formats* after these *Command Descriptions*.

Examples: Upload data from memory for 39-IM with ID=01 (user input in bold). (Click Capture on Toolbar and enter desired filename in dialog box before beginning upload.)

```
S>#01dd1,200    (Upload scans 1 through 200)
S>#01dd1       (Upload scan 1)
S>#01dd        (Upload all scans in memory)
```

#iiDNx

Upload last **x** scans from memory. Most often used to retrieve data periodically from 39-IM while it is on mooring. Maximum of 250 samples can be uploaded at one time with **#iiDNx**. **You do not need to stop logging (#iiStop) before sending #iiDNx.**

Example: For a system with 39-IMs with ID=01, 02, and 03 which is sampling every 10 minutes (144 times/day), upload latest data once per day (user input in bold):

(Click Capture on Toolbar and enter desired filename in dialog box.)

```
S>#01dn144      (upload last 144 samples from 39-IM 01)
S>stayon       (reset time-out timer on all 39-IMs so 02 and 03 do not go to sleep while uploading data from 01)
S>#02dn144      (upload last 144 samples from 39-IM 02)
S>stayon       (reset time-out timer on all 39-IMs so 01 and 03 do not go to sleep while uploading data from 02)
S>#03dn144      (upload last 144 samples from 39-IM 03)
S>stayon       (reset time-out timer on all 39-IMs so 01 and 02 do not go to sleep while uploading data from 03)
S>pwroff       (send power-off command to all 39-IMs; logging not affected)
```

Acquisition Microcontroller Data Upload Commands (*continued*)*Binary Upload:*

Binary upload, useful for large data sets, is faster than ASCII upload. **Binary upload is available only when the 39-IM is in Serial Mode (i.e., cable is connected to the 39-IM internal RS-232 connector instead of communicating through the IMM/SIM).** When binary upload is commanded, SEATERM uploads data in binary and then converts to ASCII engineering units, **resulting in a .asc file with the same format as from an ASCII upload.**

Note that data output after manually sending the binary data upload command is not usable. When you use SEATERM's Upload button or Upload Data in the Data menu, SEATERM converts the binary data to ASCII engineering units.

DB,n,b,e

Upload data **in binary** at baud **n** from scan **b** to **e**. Baud (**n**) can be 300, 600, 1200, 2400, 4800, 9600, 19200, 28800, 38400, 57600, or 115200. First scan is number 1. If **DB,n,b** is sent, only scan **b** is uploaded. If **DB,n** is sent, all scans are uploaded. As data uploads, screen first displays *start time =*, *sample interval =*, and *start sample number =*. These are start time, sample interval, and starting sample number for last set of logged data, which can be useful in determining what data to review.

Send Stop to stop logging before sending DB,n,b,e.

Note:

Because binary upload is available only when the 39-IM is in Serial Mode, the **#ii** prefix is never used with this command.

Example: Upload data from memory for 39-IM with ID=01 (user input in bold).
(Before beginning upload: Connect to internal RS-232 connector. In the Configure menu, select SBE 39IM. In the Configuration Options dialog box, on the COM Settings tab select RS-232. On the Upload Settings tab, select *Upload data in binary format*. Select the desired upload baud rate. Select whether to upload the entire data set as a single file, or to upload by user-selected scan number range. Click OK to exit dialog box.)
(Click Connect on Toolbar.)
S> (Click Upload on Toolbar)

#ii*DB

Display binary upload parameters. Each parameter is separated by comma and space. List below includes, where applicable, command used to modify parameter.

- Sample interval time [**#iiInterval=**]
- 39-IM configuration -
0 = temperature only,
1 = temperature and pressure
- Number of samples in memory
- Scan length in bytes for binary upload

Acquisition Microcontroller Testing Commands

Data obtained with these commands is **not** stored in FLASH memory.

Note:

#iSS can be sent while logging.

#iSS	Output averaged raw data – average, maximum, minimum, and number of samples. Continue averaging.
#iTT	Measure temperature for 100 samples, output converted data (°C).
#iTP	Measure pressure for 100 samples, output converted data (dbars).
#iTTR	Measure temperature for 100 samples, output raw data.
#iTPR	Measure pressure for 100 samples, output raw data.

Acquisition Microcontroller Calibration Coefficients Commands

Notes:

- Dates shown are when calibrations were performed. Calibration coefficients are initially factory-set and should agree with Calibration Certificates shipped with 39-IM.
- See individual Coefficient Commands below for definitions of the data in the example.

#iiDC

Display calibration coefficients.
Equivalent to Coefficients on Toolbar.

Example: 39-IM with ID=01 with pressure sensor (user input shown in bold).

```
S>#01dc
SBE39-IM V 1.1 09876
temperature: 08-jun-08
  TA0 = -1.832009e-05
  TA1 = 2.734858e-04
  TA2 = -2.256553e-06
  TA3 = 1.506616e-07
pressure S/N 123, range = 1450 psia: 08-jun-08
  PA0 = -2.282675e-01
  PA1 = 6.835802e-02
  PA2 = -3.570401e-09
  PTHA0 = -8.343879e+01
  PTHA1 = 6.185825e-02
  PTHA2 = -1.732684e-06
  PTCA0 = -1.977239e+02
  PTCA1 = -4.187966e-01
  PTCA2 = 1.170908e-02
  PTCB0 = 2.487150e+01
  PTCB1 = -1.900000e-03
  PTCB2 = 0.000000e+00
  POFSET = 0.000000e+00
```

Individual Coefficient Commands listed below modify a particular coefficient or date:

Note:

F = floating point number
S = string with no spaces

#iiTCalDate=S	S=Temperature calibration date.
#iiTA0=F	F=Temperature A0.
#iiTA1=F	F=Temperature A1.
#iiTA2=F	F=Temperature A2.
#iiTA3=F	F=Temperature A3.
#iiPCalDate=S	S=Pressure calibration date.
#iiPA0=F	F=Pressure A0.
#iiPA1=F	F=Pressure A1.
#iiPA2=F	F=Pressure A2.
#iiPTHA0=F	F=Pressure thermistor coefficient A0.
#iiPTHA1=F	F=Pressure thermistor coefficient A1.
#iiPTHA2=F	F=Pressure thermistor coefficient A2.
#iiPTCA0=F	F=Pressure ptca0.
#iiPTCA1=F	F=Pressure ptca1.
#iiPTCA2=F	F=Pressure ptca2.
#iiPTCB0=F	F=Pressure span TC b0.
#iiPTCB1=F	F=Pressure span TC b1.
#iiPTCB2=F	F=Pressure span TC b2.
#iiPOffset=F	F=Pressure offset (dbars).

Data Output Formats

Notes:

i = 39-IM ID

s = 39-IM serial number

t = temperature (°C, ITS-90)

p = pressure (decibars); sent only if optional pressure sensor installed

hh:mm:ss = hour, minute, second

dd mmm yyyy = day, month (Jan, Feb, Mar, etc.), year

mm-dd-yyyy = month, day, year

sample = six-digit sample number, sent only if **#iiTxSampleNum=Y**

n = number of data samples

contained in average

(n=1 for single sample

command response)

- Leading zeros are suppressed, except for one zero to the left of the decimal point (for example, a temperature of 0.1034).
- The 39-IM's pressure sensor is an absolute sensor, so its **raw** output includes the effect of atmospheric pressure (14.7 psi). As shown on the Calibration Sheet, Sea-Bird's calibration (and resulting calibration coefficients) is in terms of psia. However, when outputting pressure in **decibars**, the 39-IM outputs pressure relative to the ocean surface (i.e., at the surface the output pressure is 0 decibars). The 39-IM uses the following equation to convert psia to decibars:
pressure (db) =
[pressure (psia) - 14.7] * 0.689476

Each scan ends with a carriage return <CR> and line feed <LF>.

The 39-IM transmits data in engineering units (except for in response to **#iiTSR** and **#iiSLTR**, which request raw data). The exact format of the output varies, depending on the command sent, and whether pressure is stored with the data.

!iiData or Dataii Output

The sample number is the number of samples in FLASH memory at the time the command to take a sample (**GData**) was sent.

If **#iiFormat=0 or 1:**

ii, sssss, ttt.tttt, pppp.ppp, dd mmm yyyy, hh:mm:ss, sample, n

If **#iiFormat=2:**

ii, sssss, ttt.tttt, pppp.ppp, mm-dd-yyyy, hh:mm:ss, sample, n

#iiSL, #iiSLT, #iiTS, or #iiTSS Output

The sample number is the number of samples in FLASH memory at the time the command to take a sample was sent.

If **#iiFormat=0 or 1:**

sssss, ttt.tttt, pppp.ppp, dd mmm yyyy, hh:mm:ss

If **#iiFormat=2:**

sssss, ttt.tttt, pppp.ppp, mm-dd-yyyy, hh:mm:ss

#iiTSR or #iiSLTR Output

ttttt.t,ppppp.p,qqqqqq.q

(t = temperature sensor A/D counts, p = pressure sensor A/D counts, q = pressure sensor temperature compensation A/D counts)

Data Upload Command (#iiDNx; #iiDDb,e; Toolbar Upload button; or Upload Data in Data menu) Output

If **#iiFormat=0 or 1:**

ttt.tttt, pppp.ppp, dd mmm yyyy, hh:mm:ss

If **#iiFormat=2:**

ttt.tttt, pppp.ppp, mm-dd-yyyy, hh:mm:ss

Note that data output after *manually* sending binary data upload command (**DB,n,b,e**) is not usable.

Setup for Deployment

1. Install new batteries (see *Section 5: Routine Maintenance and Calibration*) or ensure the existing batteries have enough capacity to cover the intended deployment.
2. Program the 39-IM for the intended deployment (see *Section 3: Preparing SBE 39-IM for Deployment* for connection information; see information in this section on commands and sampling modes):

Notes:

- If the batteries have been removed, date and then time must be reset.
- **Always set date and then time.** If a new date is entered but not a new time, the new date will not be saved. If a new time is entered without first entering a new date, the date will reset to the last date it was set for with **MMDDYY=**, **DDMMYY=**, **#iiMMDDYY=**, or **#iiDDMMYY=**.
- An alternate command to set date and time is **#iiDateTime=**.

- A. Ensure all data has been uploaded, and then set **#iiSampleNum=0** to make the entire memory available for recording. If **#iiSampleNum=** is not reset to 0, data will be stored after the last recorded sample.
- B. Set the date and then time. Note that the date and time can be set globally for all IM instruments on-line (**MMDDYY=** or **DDMMYY=** to set date; **HHMMSS=** to set time) or individually for each IM instrument (**#iiMMDDYY=** or **#iiDDMMYY=** to set date; **#iiHHMMSS=** to set time). To synchronize autonomous sampling for a system with multiple IM instruments on a mooring cable, set the date and time globally, with all the IM instruments on-line (see *Autonomous Sampling (Logging Commands)* for details on synchronization).
- C. Establish the setup and sampling parameters.
- D. If the system will have multiple IM instruments on the mooring cable, verify the 39-IM is set to *Prompt ID* to allow use of the Toolbar buttons and Menus:
 - 1) In the Configure menu, select **SBE 39IM**.
 - 2) Click on the COM Settings tab.
 - 3) For Modem/RS485 ID, click on *Prompt ID*.
 - 4) Click OK.
- E. Use **one** of the following to initiate logging:
 - **#iiStartNow**, **#iiStartInterval**, **#iiResumeLogging**, **#iiGetAvgRestart**, or **#iiGetLastRestart** to start logging now, taking a sample every **#iiInterval** seconds.
 - **#iiStartMMDDYY=**, **#iiStartHHMMSS=**, and **#iiStartLater** to start logging at the specified date and time, taking a sample every **#iiInterval** seconds.
 - **!iiSetGDataStr=** (to define the command sent to the acquisition microcontroller when **GData** is sent) and then **GData** (to globally start logging now for all IM instruments on-line, taking a sample every **#iiInterval** seconds).

Note:

For commands used to *start logging now* (listed at right), logging actually starts 10 seconds, (**#iiInterval** / 2), or **#iiInterval** from when the start logging command is received by the 39-IM, depending on the command used. See the individual command descriptions for the start timing.

Attaching SBE 39-IM to Mooring Cable

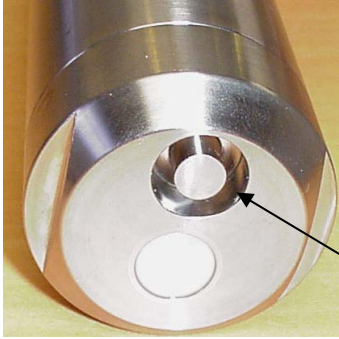

Air space
around
embedded
thermistor

For an SBE 39-IM with an embedded (internal) thermistor, there is a *depression* in the end cap around the thermistor. **Do not deploy the 39-IM with the end cap up**, as sediment and/or non-flushing water can get trapped in this space, affecting the response of the thermistor.

SBE 39-IM without Optional Fairing / Net Fender

Mounting guide / inductive modem coupler – contains modem coupling toroid core. Cable goes through here but is **not clamped**, to avoid putting through tension on end cap (which could pull off end cap).

For both mounting brackets – loosen hardware to separate bracket halves and mount on mooring cable

Mounting clamp, with opening sized to specified cable diameter – cable **clamped** by this bracket. Note: Installing clamp on larger cable than specified may cause damage to cable and/or modem and prevent IM communications.

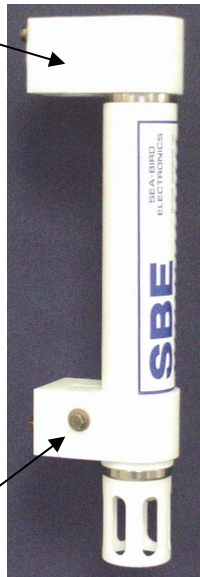

1. Attach the mounting brackets to the insulated mooring cable:
 - A. Open each mounting bracket by unthreading the two large titanium hex bolts.
 - B. Place the insulated mooring cable inside the brackets' grooves.
 - C. Reinstall each bracket half with the hex bolts.
 - D. Verify that the two halves of the modem coupling toroid have come together evenly, and that the mounting clamp is secure.
2. Verify that the hardware and external fittings are secure.

Mounting guide / Inductive Modem Coupler Detail (Note: Photo is 37-IMP; detail similar for 39-IM)

Guide is sized *slightly* bigger than specified cable diameter, to allow cable to pass through freely but limit vibration of 39-IM on cable

For proper communications, 2 halves of modem coupling toroid core must mate, with no gaps

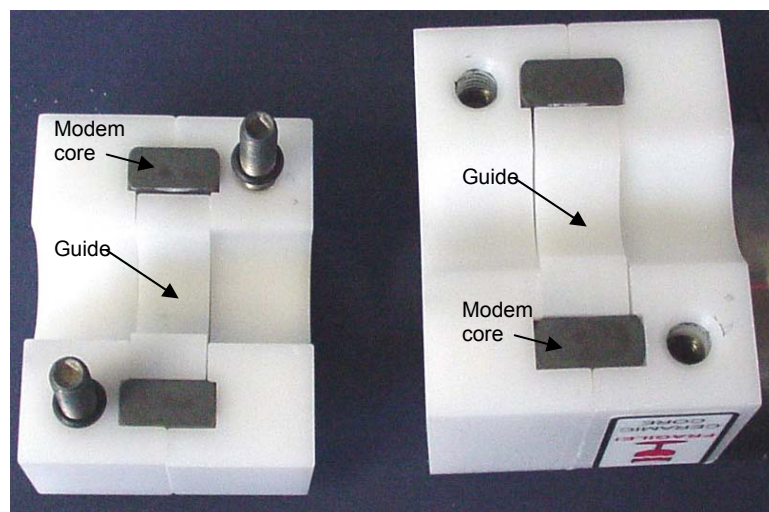

SBE 39-IM with Optional Fairing / Net Fender

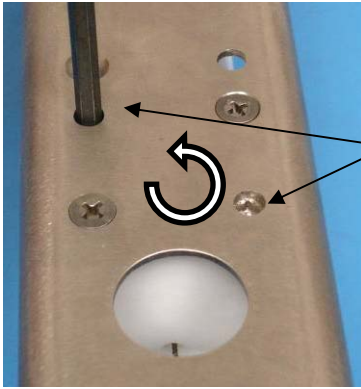

Loosen bolts through holes in fairing (2 bolts each end)

1. Remove the 39-IM from the fairing:

- A. Insert a 3/16 inch Allen wrench through the **countersunk** holes in the fairing to loosen the four mounting clamp bolts (two for each end).
- B. When all four bolts are loosened, remove the 39-IM from the fairing. Note: The other half of the mounting brackets remain attached to the fairing, and the mounting bolts remain attached to the retained portions of the brackets.

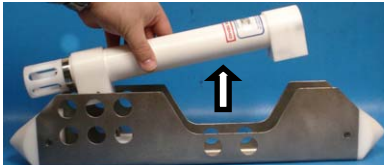

Note orientation of 39-IM in fairing; re-install with same orientation

2. Install the 39-IM and fairing on the insulated mooring cable:

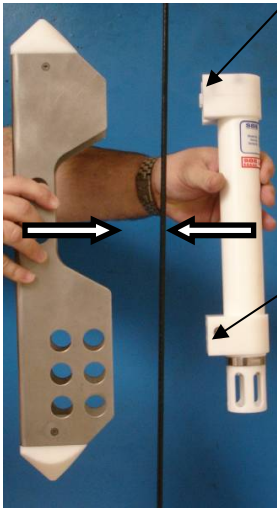

Mounting guide / inductive modem coupler – contains modem coupling toroid core. Cable goes through here but is **not clamped**, to avoid putting through tension on end cap (which could pull off end cap).

Mounting clamp, with opening sized to specified cable diameter – cable **clamped** by this bracket. Note: Installing clamps on larger cable than specified may cause damage to cable and/or modem and prevent IM communications.

- A. Bringing the 39-IM and the fairing together, place the insulated mooring cable inside the brackets' grooves.
- B. Use a 3/16 inch Allen wrench to tighten the four mounting clamp bolts through the countersunk holes in the back of the fairing.
- C. Verify that the two halves of the modem coupling toroid have come together evenly, and that the mounting clamp is secure.

Mounting guide / Inductive Modem Coupler Detail (Note: Photo is 37-IMP; detail similar for 39-IM)

Guide is sized *slightly* bigger than specified cable diameter, to allow cable to pass through freely but limit vibration of 39-IM on cable

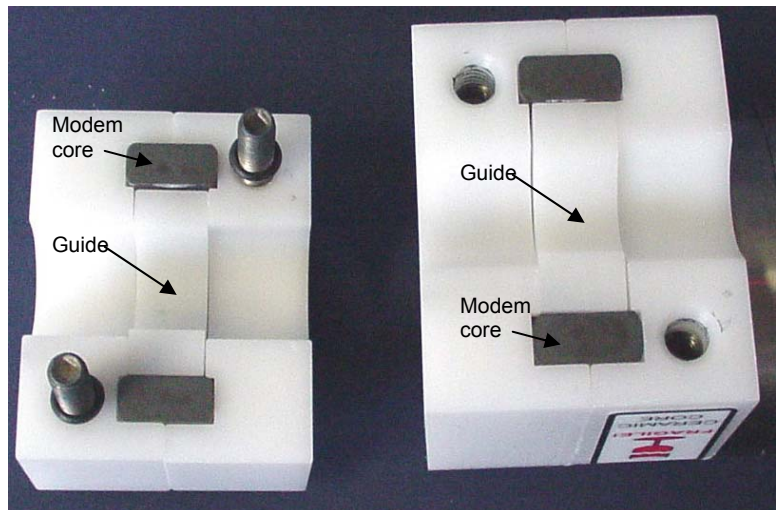

Tighten bolts through holes in fairing (2 bolts each end)

For proper communications, 2 halves of modem coupling toroid core must mate, with no gaps

3. Verify that the hardware and external fittings are secure.

System Installation and Wiring

For system installation and wiring details, refer to:

- *Mooring Cable and Wiring Requirements in Section 2: Description of SBE 39-IM*
- *Inductive Modem Module Manual*
- *Appendix IV: SIM Hookup and Configuration.*

Installing Optional Inductive Cable Coupler (ICC)

1. Loosen the titanium hex head bolts connecting the two halves of each of the ICC brackets. Pull the halves apart.
2. Place the insulated mooring cable inside the brackets' grooves.
3. Reinstall each bracket half with the hex bolts.
4. Verify that the two halves of the modem coupling toroid have come together evenly, and that the mounting clamp is secure.

Note:

See *Application Note 85: Handling of Ferrite Core on Instruments with Inductive Modem Telemetry* for more detailed information on handling and installation.

Mounting clamp, with opening sized to specified cable diameter – cable **clamped** by this bracket.

Note: Installing clamps on larger cable than specified may cause damage to cable and/or modem and prevent IM communications.

Mounting guide / inductive modem coupler – contains modem coupling toroid. Cable goes through here but is **not clamped**, to avoid putting through tension on end cap (which could pull off end cap). **Detail of guide and core is similar to shown above for the 39-IM guide and core.**



Recovery

WARNING!

If the 39-IM stops working while underwater, is unresponsive to commands, or shows other signs of flooding or damage, carefully secure it away from people until you have determined that abnormal internal pressure does not exist or has been relieved. Pressure housings may flood under pressure due to dirty or damaged o-rings, or other failed seals. When a sealed pressure housing floods at great depths and is subsequently raised to the surface, water may be trapped at the pressure at which it entered the housing, presenting a danger if the housing is opened before relieving the internal pressure. Instances of such flooding are rare. However, a housing that floods at 5000 meters depth holds an internal pressure of more than 7000 psia, and has the potential to eject the end cap with lethal force. A housing that floods at 50 meters holds an internal pressure of more than 85 psia; this force could still cause injury.

If you suspect the 39-IM is flooded, point it in a safe direction away from people. Slowly turn the end cap $\frac{1}{4}$ turn at a time (using a wrench on the end cap's wrench flats), letting the internal pressure bleed off slowly past the o-rings as the o-rings are released from the housing. Then, you can completely remove the end cap and electronics from the housing.

1. Rinse the 39-IM with fresh water, and dry thoroughly.
2. If immediate redeployment is not required, it is best to leave the 39-IM with batteries in place and in a quiescent (sleep) state (**PwrOff**), so that date and time are retained. Because the quiescent current required is less than 20 microAmps, the batteries can be left in place without significant loss of capacity (less than 17% loss per year).

Uploading Data

Note:

The uploaded data format is the same, regardless of the choice of upload telemetry (inductive modem or RS-232) and type (ASCII or binary).

Data can be uploaded using one of these telemetry methods:

- **RS-232 (serial mode)** – Much faster upload is available in serial mode; however, you must open the 39-IM housing to access the internal RS-232 serial connector. The RS-232 telemetry allows ASCII or binary upload; binary upload is inherently twice as fast as ASCII upload. Additionally, the RS-232 telemetry can upload in binary at up to 115,200 baud.
- **Inductive modem** – Data can be uploaded in ASCII while the 39-IM is deployed, or is wired in the lab as shown in *Test Setup* in *Section 3: Preparing SBE 39-IM for Deployment*. Upload speed is limited by the baud rate between the 39-IM and the IMM/SIM: 1200 baud. We recommend uploading with IM telemetry only if you are interested in looking at a small amount of data or need to upload the data without recovering the instrument.

Upload Using RS-232 (Serial Mode) Telemetry

After recovery:

1. Remove the sensor end cap and electronics from the housing (see *Battery Replacement* in *Section 5: Routine Maintenance and Calibration* for details).
2. Attach the RS-232 cable (supplied by Sea-Bird) to the internal RS-232 connector and to the computer.

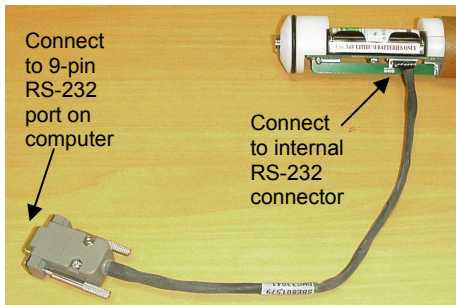

RS-232 cable supplied by Sea-Bird

Proceed as follows:

1. Double click on SeaTerm.exe. The display shows the main screen.
2. In the Configure menu, select **SBE 39IM**. The dialog box looks like this:

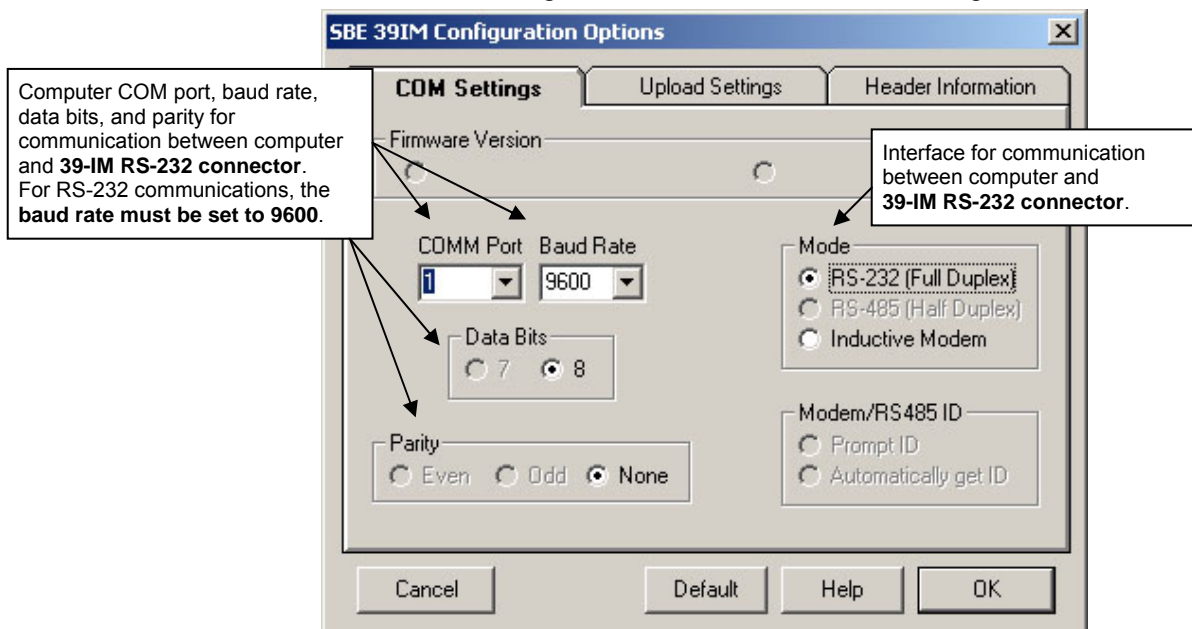

Make the selections for COM settings.

Note:

Set up **Upload Settings**, **Header Information**, and/or **Header Form** (Steps 3 through 5):

- The first time you upload data, and
- If you want to change upload or header parameters.

3. Click the Upload Settings tab. The dialog box looks like this:

Baud for communication between **39-IM RS-232 Connector and computer** for uploading data from 39-IM to computer.

- **Upload data in binary format selected:** upload baud rates up to 115,200 are available.
- **Upload data in binary format not selected:** upload baud is same as baud for RS-232 communication, 9600 baud.

Defines data upload type when using Upload button on Toolbar or Upload Data in Data menu:

- All as single file – All data uploaded into one file.
- By scan number range – SEATERM prompts for beginning and ending scan (sample) numbers, and uploads all data within range into 1 file.

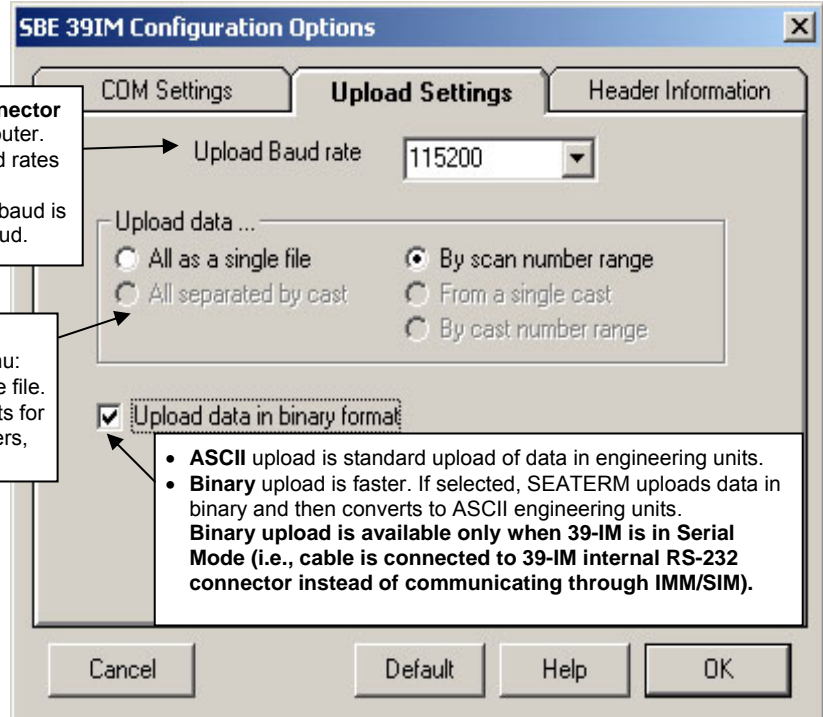

- **ASCII** upload is standard upload of data in engineering units.
- **Binary** upload is faster. If selected, SEATERM uploads data in binary and then converts to ASCII engineering units. **Binary upload is available only when 39-IM is in Serial Mode (i.e., cable is connected to 39-IM internal RS-232 connector instead of communicating through IMM/SIM).**

Make the selection for Upload Settings.

4. Click the Header Information tab. The dialog box looks like this:

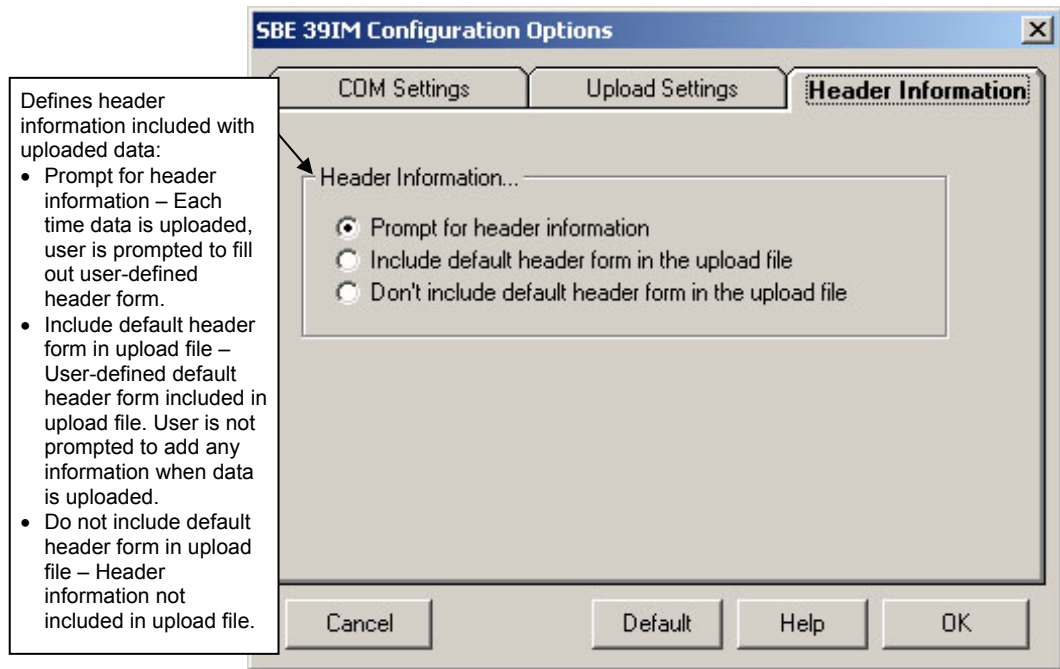

Select the desired header information option. Click OK to save the settings.

5. In the Configure menu, select Header Form to customize the header. The dialog box looks like this (default prompts are shown):

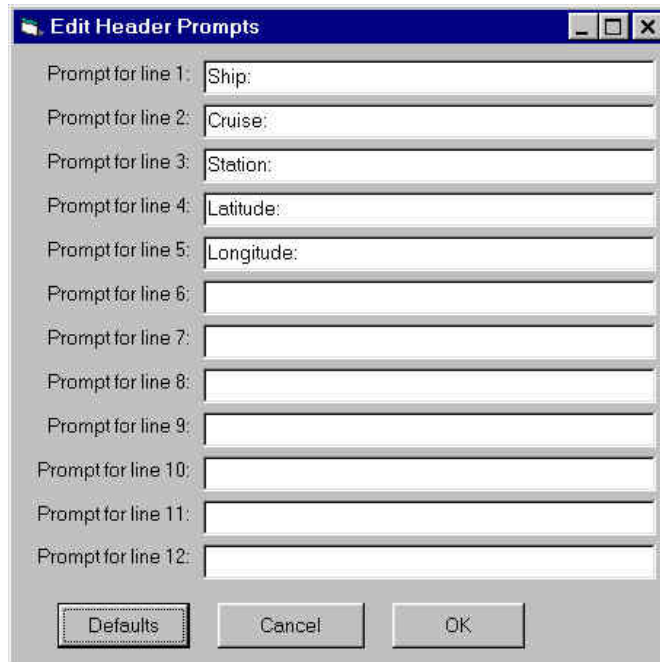

The entries are free form, 0 to 12 lines long. This dialog box establishes:

- the header prompts that appear for the user to fill in when uploading data, if *Prompt for header information* was selected in the Configuration Options dialog box (Step 4)
- the header included with the uploaded data, if *Include default header form in upload file* was selected in the Configuration Options dialog box (Step 4)

Enter the desired header/header prompts. Click OK.

6. Click Connect on the Toolbar to begin communications with the 39-IM. The display looks like this:

```
SBE 39-IM
S>
```

This shows that correct communications between the computer and 39-IM has been established.

If the system does not respond as shown above:

- Click Connect again.
- Check cabling between the computer and 39-IM.
- Verify the correct instrument was selected and the COM settings were entered correctly in the Configure menu.

Notes:

- When communicating with RS-232 telemetry, do not precede commands with **#ii** (for example, send **Stop** instead of **#01Stop**).
- You may need to send **Stop** several times to get the 39-IM to respond.

7. If sampling autonomously, command the 39-IM to stop logging by pressing the Enter key and sending **Stop**.

8. Display 39-IM status information by clicking Status on the Toolbar. The display looks like this:

```
SBE 39-IM V 1.1 SERIAL NO. 9876 22 Jul 2008 15:01:39
battery voltage = 8.0
not logging: received stop command
sample interval = 10 seconds
samplenummer = 1000, free = 2980824
SBE 39-IM configuration = temperature and pressure
transmit sample number
temperature = 9.64 deg C
```

Note:

Sea-Bird software does not correct for clock drift.

Compare the 39-IM's real-time clock data to actual time. This information can be useful later, if you need to correct for clock drift.

9. Click Upload on the Toolbar to upload stored data. SEATERM responds as follows:

Note:

While uploading data, **Warning: Low Battery Voltage** may be displayed. To continue uploading, remove the batteries and install new ones. The momentary loss of power resets the clock, preventing analysis of any clock drift, and erases the 256 byte cache buffer data (most recently recorded data, corresponding to no more than 36 data samples). Note that all but the most recent data is stored in non-volatile FLASH memory, which is not affected by loss of power. See *Battery Replacement* in *Section 5: Routine Maintenance and Calibration* for replacement of the batteries. See *Memory* in *Appendix I: Functional Description* for a discussion of the cache buffer.

- A. SEATERM sends the status (**DS**) command, displays the response, and writes the command and response to the upload file. **DS** provides you with information regarding the number of samples in memory as well as the instrument setup.
- B. **If you selected *By scan number range* in the Configuration Options dialog box (Configure menu)** – a dialog box requests the range. Enter the desired value(s), and click OK.
- C. SEATERM sends the calibration coefficients (**DC**) command, displays the response, and writes the command and response to the upload file. **DC** displays the 39-IM's calibration coefficients.
- D. **If you selected *Prompt for header information* in the Configuration Options dialog box (Configure menu)** – a dialog box with the header form appears. Enter the desired header information, and click OK.
- E. In the Open dialog box, enter the desired upload file name and click OK. The upload file has a .asc extension.
- F. SEATERM sends the data upload command (**DDb,e** or **DB,n,b,e**, depending on if you selected binary upload on the Upload Settings tab of the Configuration Options dialog box in Step 3).
- G. When the data has been uploaded, SEATERM shows the S> prompt.

Upload Using Inductive Modem Telemetry (recommended only for uploading small amounts of data)

Note:

We recommend uploading with IM telemetry only if you are interested in looking at a small amount of data or need to upload the data without recovering the instrument.

Data may be uploaded using the inductive modem telemetry during deployment or after recovery.

- If uploading **after recovery**, see the wiring description in *Power and Communications Test and Setting SBE 39-IM IDs* in *Section 3: Preparing SBE 39-IM for Deployment*. Set Modem/RS485 ID (on COM Settings tab of SBE 39 Configuration Options dialog box) to *Automatically get ID*.
- If uploading **during deployment**, leave Modem/RS485 ID on *Prompt ID*. SEATERM will prompt you for the 39-IM ID when you use Toolbar or menu shortcuts for commands.

Proceed as follows (procedure is provided for use with the SIM; procedure for IMM is similar):

1. Double click on SeaTerm.exe. The display shows the main screen.
2. In the Configure menu, select **SBE 39IM**. For the COM Settings tab, see *Test and Set SBE 39-IM ID* in *Section 3: Preparing SBE 39-IM for Deployment*. Then click on the Upload Settings tab. The dialog box looks like this:

Note:

Set up **Upload Settings, Header Information, and/or Header Form** (Steps 2 through 4):

- The first time you upload data, and
- If you want to change upload or header parameters.

Baud rate for communication between **IMM/SIM and computer** for uploading data from 39-IM to computer. Same as baud rate for general communication, which was set on COM Settings tab.

Defines data upload type when using Upload on Toolbar or Upload Data in Data menu:

- All as single file – All data uploaded into one file.
- By scan number range – SEATERM prompts for beginning and ending scan (sample) numbers, and uploads all data within range into one file.

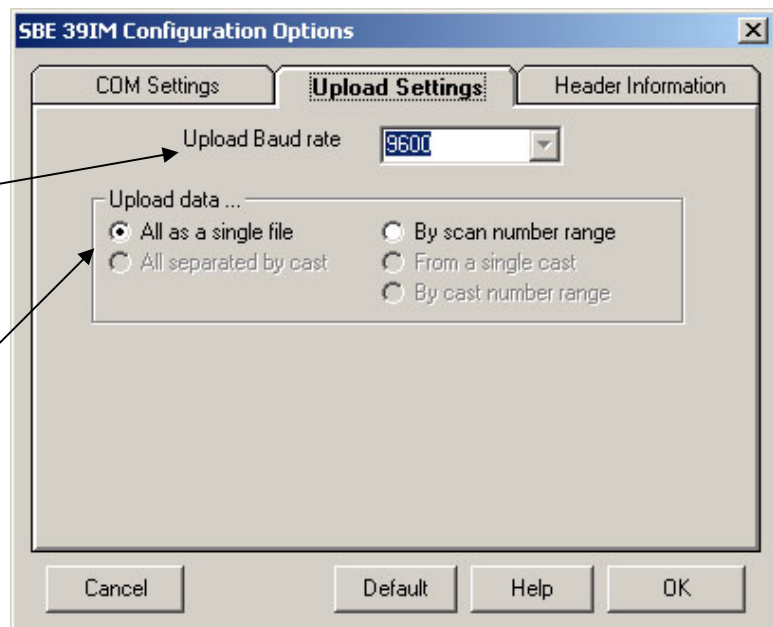

Make the selection for Upload Settings.

3. Click on the Header Information tab. The dialog box looks like this:

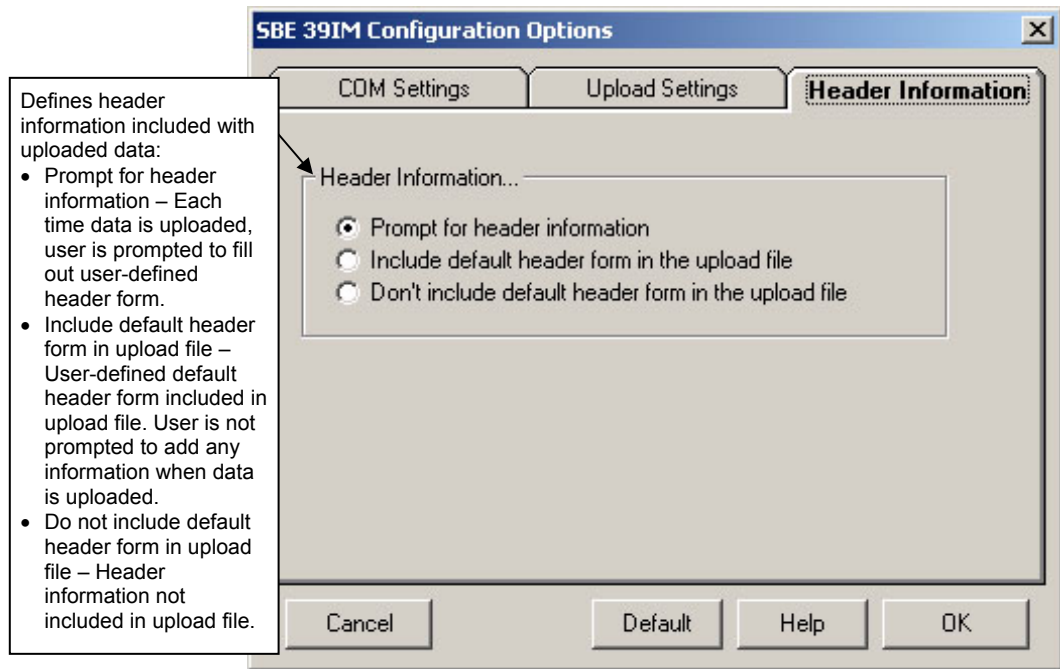

Select the desired header information option. Click OK to save the settings.

4. In the Configure menu, select Header Form to customize the header. The dialog box looks like this (default prompts are shown):

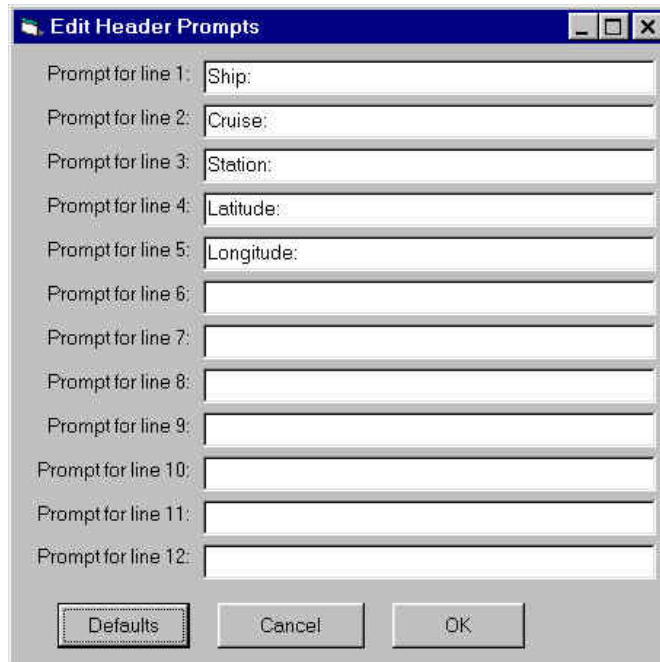

The entries are free form, 0 to 12 lines long. This dialog box establishes:

- the header prompts that appear for the user to fill in when uploading data, if *Prompt for header information* was selected in the Configuration Options dialog box (Step 3)
- the header included with the uploaded data, if *Include default header form in upload file* was selected in the Configuration Options dialog box (Step 3)

Enter the desired header/header prompts. Click OK.

Note:

The display shows 37 because the SIM was originally developed for the SBE 37-IM MicroCAT.

5. Turn on the SIM power supply (if already on, turn it off and then on again). The display looks like this:

```
SBE 37 SURFACE MODEM V 3.0
S>
Sending wake up tone, wait 4 seconds
S>
```

This shows that correct communications between the computer and SIM has been established, and the SIM has sent the wake-up signal to the IM instrument(s).

If the system does not respond as shown above:

- Click Connect on the Toolbar.
- Check cabling between the computer, SIM, and IM instrument(s).
- Verify the correct instrument was selected and the COM settings were entered correctly in the Configure menu.

Note:

You may need to send **#iiStop** several times to get the 39-IM to respond.

6. If sampling autonomously, command the 39-IM to stop logging by pressing the Enter key and sending **#iiStop**.

7. Display 39-IM status information by clicking Status on the Toolbar. The display looks like this:

```
SBE 39-IM V 1.1 SERIAL NO. 9876 22 Jul 2008 15:01:39
battery voltage = 8.0
not logging: received stop command
sample interval = 10 seconds
samplenummer = 1000, free = 2980824
SBE 39-IM configuration = temperature and pressure
transmit sample number
temperature = 9.64 deg C
```

Note:

Sea-Bird software does not correct for clock drift.

Compare the 39-IM's real-time clock data to actual time. This information can be useful later, if you need to correct for clock drift.

Note:

While uploading data, Warning: Low Battery Voltage may be displayed. To continue uploading, remove the batteries and install new ones. The momentary loss of power resets the clock, preventing analysis of any clock drift, and erases the 256 byte cache buffer data (most recently recorded data, corresponding to no more than 36 data samples). Note that all but the most recent data is stored in non-volatile FLASH memory, which is not affected by loss of power. See *Battery Replacement* in Section 5: *Routine Maintenance and Calibration* for replacement of the batteries. See *Memory* in Appendix I: *Functional Description* for a discussion of the cache buffer.

8. Click Upload on the Toolbar to upload stored data. SEATERM responds as follows:
 - A. SEATERM sends the status (**#iiDS**) command, displays the response, and writes the command and response to the upload file. **#iiDS** provides you with information regarding the number of samples in memory as well as the instrument setup.
 - B. **If you selected *By scan number range* in the Configuration Options dialog box (Configure menu)** – a dialog box requests the range. Enter the desired value(s), and click OK.
 - C. SEATERM sends the calibration coefficients (**#iiDC**) command, displays the response, and writes the command and response to the upload file. **#iiDC** displays the 39-IM's calibration coefficients.
 - D. **If you selected *Prompt for header information* in the Configuration Options dialog box (Configure menu)** – a dialog box with the header form appears. Enter the desired header information, and click OK.
 - E. In the Open dialog box, enter the desired upload file name and click OK. The upload file has a .asc extension.
 - F. SEATERM sends the data upload command (**#iiDDb,e**).
 - G. When the data has been uploaded, SEATERM shows the S> prompt.

Processing Data

Ensure all data has been uploaded from the 39-IM by reviewing the data. Sea-Bird provides two options for reviewing/processing the data:

- Use **Plot39** to plot the ASCII (.asc) data (see *Appendix II: Plot39 Data Plotting Program*); **OR**
- Use **SEATERM's Convert utility** to convert the .asc file to a .cnv file that can be used by SBE Data Processing. SBE Data Processing includes many post-processing modules; the only modules applicable to the 39-IM are ASCII Out and SeaPlot.
 1. In SEATERM, click Convert on the Toolbar. The Convert dialog box appears.
 - Enter the input (.asc) file name and the desired output (.cnv) file name; file names must include the path.
 - If desired, click *Start new year at Julian time 0* to reset the Julian Day to 0 on January 1. In processing the data, date and time is converted to Julian Day with five significant digits. As the default, Convert does not reset the Julian Day to 0 when rolling over from December 31 to January 1.
 - If desired, click *Convert pressure to depth*. If clicked, a field for the latitude to be used in the depth calculation appears in the dialog box; enter the latitude (in degrees) at which the instrument was deployed. Convert will replace the pressure column with a depth column in the output file.
 2. After the data is converted, use SBE Data Processing to process the .cnv data (see the software manual on CD-ROM or Help files).

Notes:

To prepare the 39-IM for re-deployment:

1. After all data has been uploaded, send **#iiSampleNum=0**. If this command is not sent, new data will be stored after the last recorded sample, preventing use of the entire memory capacity.
2. Do *one* of the following:
 - Send **PwrOff** to put the 39-IM in quiescent (sleep) state until ready to redeploy. Leaving the 39-IM with the batteries in place and in quiescent state retains the date and time. Quiescent current is only 20 microAmps, so the batteries can be left in place without significant loss of capacity.
 - Send a command to begin logging immediately (see *Command Descriptions*).
 - Set a date and time for logging to start using one of the following sets of commands -
 - **#iiStartDateTime=** and **#iiStartLater**
 - **#iiStartMMDDYY=** or **#iiStartDDMMYY=**,
 - #iiStartHHMMSS=**, and **#iiStartLater**.

Section 5: Routine Maintenance and Calibration

This section reviews corrosion precautions, battery replacement, pressure sensor maintenance, and sensor calibration. The 39-IM's accuracy is sustained by care and calibration of the sensors and establishing proper handling practices.

Corrosion Precautions

All exposed materials are titanium or plastic. No corrosion precautions are required, but direct electrical connection of the 39-IM (titanium) housing to mooring or other dissimilar metal hardware should be avoided. Rinse the 39-IM with fresh water after use and prior to storage.

Battery Replacement



Note:
See *Shipping Precautions* in *Section 1: Introduction* for details on shipping spare batteries.

Sea-Bird ships the 39-IM with **two 3.6 volt, AA lithium batteries** installed. Follow the instructions below to change the batteries, using 3.6 volt AA lithium batteries manufactured by Saft or Tadiran. These batteries are non-hazardous (as defined by IATA or US DOT) and can be shipped either separately or installed in the 39-IM. **Do not use AA alkaline batteries.**

1. Wipe the outside of the sensor end cap and housing dry, being careful to remove any water at the seam between them.
2. Remove the sensor end cap from the housing:
 - A. Using a wrench on the end cap's wrench flats, unscrew the end cap.
 - B. Pull the end cap and attached electronics out of the housing. Note that the cardboard sleeve remains around the electronics.
 - C. Remove any water from the end cap O-ring and mating surfaces inside the housing with a lint-free cloth or tissue.

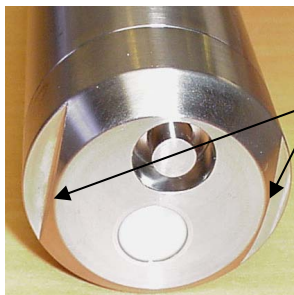

Wrench flats on end cap. Note: If your 39-IM has an external thermistor, remove temperature guard to access wrench flats.

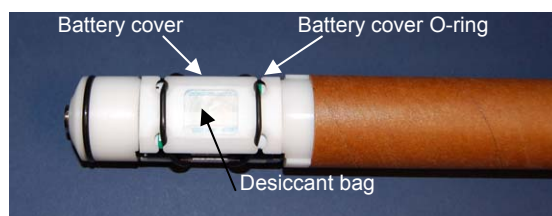
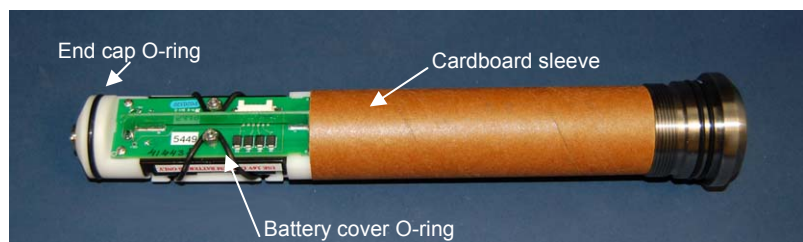

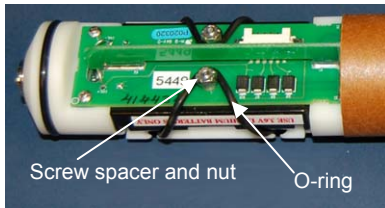

3. Replace the batteries.

- A. Carefully pull the O-ring off of the spacer and nut holding it in place.
- B. Remove the desiccant cover and desiccant bag.
- C. Replace the batteries.

**Note:**

Before delivery, a desiccant bag is placed in the housing (attached to the batteries with the battery cover), and the electronics chamber is filled with dry Argon gas. These measures help prevent condensation.

To ensure proper functioning:

1. **Install a new desiccant bag each time you open the housing.** If a new bag is not available, see *Application Note 71: Desiccant Use and Regeneration (drying)*.
2. If possible, dry gas backfill each time you open the housing. If you cannot, wait at least 24 hours before redeploying, to allow the desiccant to remove any moisture from the chamber.

- D. Place a **new desiccant bag** in the battery cover, and place the cover on the batteries.

Note: The SBE 39-IM is shipped with 25 spare desiccant bags in a small metal container.
- E. Secure the battery cover with the O-ring: Wrap the O-ring around the cover, and loop the ends over the posts formed by the spacers.

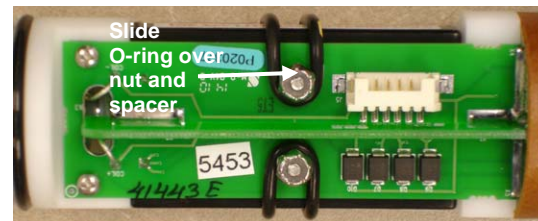
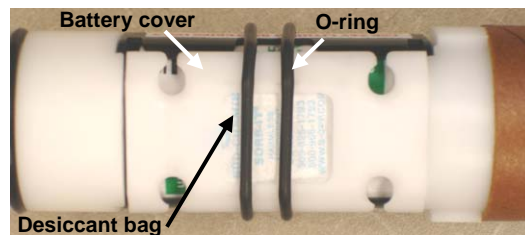

- F. Slide the O-ring into the cutouts on the battery cover.

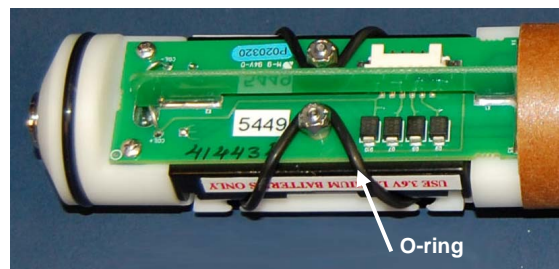
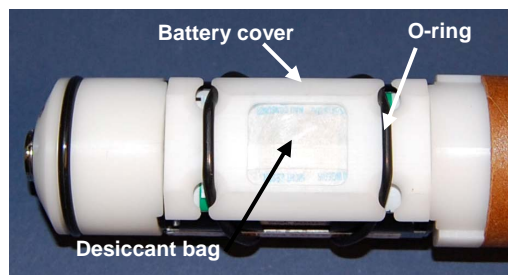

4. Reinstall the sensor end cap on the housing:

- A. Remove any water from the end cap O-ring and mating surfaces in the housing with a lint-free cloth or tissue. Inspect the O-rings and mating surfaces for dirt, nicks, and cuts. Clean as necessary. Apply a light coat of O-ring lubricant (Parker Super O Lube) to O-ring and mating surfaces.
- B. Carefully insert the electronics in the housing. Using a wrench, carefully secure the end cap to the housing.

Pressure Sensor (optional) Maintenance

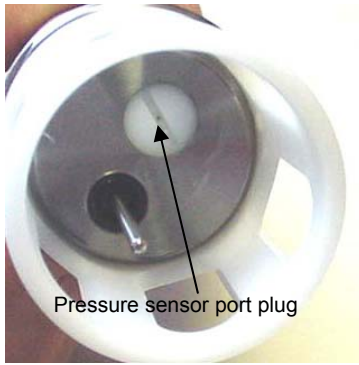

CAUTION:

Do not put a brush or any object in the pressure port. Doing so may damage or break the pressure sensor.

The pressure port plug has a small vent hole to allow hydrostatic pressure to be transmitted to the pressure sensor inside the instrument while providing protection for the pressure sensor, keeping most particles and debris out of the pressure port.

Periodically (approximately once a year) inspect the pressure port to remove any particles, debris, etc:

1. Unscrew the pressure port plug from the pressure port.
2. Rinse the pressure port with warm, de-ionized water to remove any particles, debris, etc.
3. Replace the pressure port plug.

Sensor Calibration

Sea-Bird sensors are calibrated by subjecting them to known physical conditions and measuring the sensor responses. Coefficients are then computed, which may be used with appropriate algorithms to obtain engineering units. The sensors on the 39-IM are supplied fully calibrated, with coefficients printed on the Calibration Certificate (in the manual). These coefficients have been stored in the 39-IM's EEPROM.

We recommend that the 39-IM be returned to Sea-Bird for calibration.

Temperature Sensor Calibration

The primary source of temperature sensor calibration drift is the aging of the thermistor element. Sensor drift will usually be a few thousandths of a degree during the first year, and less in subsequent intervals. Sensor drift is not substantially dependent upon the environmental conditions of use, and — unlike platinum or copper elements — the thermistor is insensitive to shock.

Pressure Sensor Calibration

The optional strain-gauge pressure sensor is a mechanical diaphragm type, with an initial static error band of 0.05%. Consequently, the sensor is capable of meeting the 39-IM's 0.10% error specification with some allowance for aging and ambient-temperature induced drift.

Pressure sensors show most of their error as a linear offset from zero. A technique is provided below for making small corrections to the pressure sensor calibration using the *offset* (**#iiPOffset=**) calibration coefficient term by comparing 39-IM pressure output to readings from a barometer.

Note:

The 39-IM's pressure sensor is an absolute sensor, so its **raw** output includes the effect of atmospheric pressure (14.7 psi). As shown on the Calibration Sheet, Sea-Bird's calibration (and resulting calibration coefficients) is in terms of psia. However, when outputting pressure in **engineering units**, the 39-IM outputs pressure relative to the ocean surface (i.e., at the surface the output pressure is 0 decibars). The 39-IM uses the following equation to convert psia to decibars:

$$\text{Pressure (db)} = [\text{pressure (psia)} - 14.7] * 0.689476$$

Allow the 39-IM to equilibrate in a reasonably constant temperature environment for at least 5 hours before starting. Pressure sensors exhibit a transient change in their output in response to changes in their environmental temperature. Sea-Bird instruments are constructed to minimize this by thermally decoupling the sensor from the body of the instrument. However, there is still some residual effect; allowing the 39-IM to equilibrate before starting will provide the most accurate calibration correction.

1. Place the 39-IM in the orientation it will have when deployed.
2. In SEATERM:
 - A. Set the pressure offset to 0.0 (**#iiPOffset=0**).
 - B. Send **#iiTP** to measure the 39-IM pressure 100 times and transmit converted data (decibars).
3. Compare the 39-IM output to the reading from a good barometer at the same elevation as the 39-IM's pressure sensor port.
Calculate *offset* = barometer reading – 39-IM reading
4. Enter the calculated offset (positive or negative) in the 39-IM's EEPROM, using **#iiPOffset=** in SEATERM.

Offset Correction Example

Absolute pressure measured by a barometer is 1010.50 mbar. Pressure displayed from 39-IM is -2.5 dbars.

Convert barometer reading to dbars using the relationship: $\text{mbar} * 0.01 = \text{dbar}$

Barometer reading = $1010.50 \text{ mbar} * 0.01 = 10.1050 \text{ dbar}$

The 39-IM's internal calculations output gage pressure, using an assumed value of 14.7 psi for atmospheric pressure. Convert 39-IM reading from gage to absolute by adding 14.7 psia to the 39-IM's output:

$-2.5 \text{ dbars} + (14.7 \text{ psi} * 0.689476 \text{ dbar/psia}) = -2.5 + 10.13 = 7.635 \text{ dbars}$

Offset = $10.1050 - 7.635 = + 2.47 \text{ dbars}$

Enter offset in 39-IM.

For demanding applications, or where the sensor's air ambient pressure response has changed significantly, calibration using a dead-weight generator is recommended. The pressure sensor port uses a $7/16-20$ straight thread for mechanical connection to the pressure source. Use a fitting that has an O-ring tapered seal, such as Swagelok-200-1-4ST, which conforms to MS16142 boss.

Section 6: Troubleshooting

This section reviews common problems in operating the SBE 39-IM, and provides the most common causes and solutions.

Problem 1: Unable to Communicate with 39-IM

The S> prompt indicates that communications between the IMM or SIM and computer have been established. Before proceeding with troubleshooting, attempt to establish communications again by clicking Connect on SEATERM's toolbar or pressing the Enter key several times.

Cause/Solution 1: The I/O cable connection may be loose. Check the cabling between the IMM or SIM and computer for a loose connection.

Cause/Solution 2: The instrument type and/or its communication settings may not have been entered correctly in SEATERM. Select the **SBE 39IM** in the Configure menu and verify the settings in the Configuration Options dialog box. The settings should match those on the instrument Configuration Sheet.

Cause/Solution 3: The I/O cable between the IMM or SIM and computer may not be the correct one. The I/O cable supplied with the IMM or SIM permits connection to standard 9-pin RS-232 interfaces.

Cause/Solution 4: The modem core in the 39-IM (and/or the ICC, if applicable) may have a gap, be misaligned, or be damaged. See *Application Note 85: Handling of Ferrite Core in Instruments with Inductive Modem Telemetry* for details on inspecting the modem core and proper installation of the 39-IM and the ICC (if applicable) on the cable.

Problem 2: No Data Recorded

Cause/Solution 1: The memory may be full; once the memory is full, no further data will be recorded. Verify that the memory is not full using **#iDS** (*free* = 0 or 1 if memory is full). Sea-Bird recommends that you upload all previous data before beginning another deployment. Once the data is uploaded, send **#iiSampleNum=0** to reset the memory. After the memory is reset, **#iDS** will show *samplenum* = 0.

Problem 3: Unreasonable T or P Data

The symptom of this problem is a data file that contains unreasonable values (for example, values that are outside the expected range of the data).

Cause/Solution 1: A data file with unreasonable (i.e., out of the expected range) values for temperature or pressure may be caused by incorrect calibration coefficients in the 39-IM. Send **#iDC** to verify the calibration coefficients in the 39-IM match the instrument Calibration Certificates. Note that calibration coefficients do not affect the raw data stored in 39-IM memory. If you have not yet overwritten the memory with new data, you can correct the coefficients and then upload the data again.

Glossary

Batteries – Two 3.6-volt AA lithium batteries manufactured by Saft (LS14500) or Tadiran.

Deployment Endurance Calculator – Sea-Bird's Windows 2000/XP software used to calculate deployment length for moored instruments, based on user-input deployment scheme, instrument power requirements, and battery capacity.

Convert – Toolbar button in SEATERM to convert ASCII (.asc) data uploaded from the 39-IM with SEATERM to .cnv format. When converted to .cnv format, SBE Data Processing can be used to analyze and display data.

ICC – Inductive Cable Coupler, which clamps to the insulated mooring cable and transfers the inductive signal on the wire to the IMM or SIM PCB installed inside the buoy or elsewhere.

IMM – Inductive Modem Module PCB, used to interface between the computer serial port and SBE 39-IMs or other compatible IM-sensors. Either an IMM or SIM is required to interface with the 39-IM.

PCB – Printed Circuit Board.

Plot39 – Win 95/98/NT/2000/XP software for plotting 39-IM data.

SBE 39 – High-accuracy temperature and optional pressure recorder with *RS-232 serial interface*.

SBE 39-IM – High-accuracy temperature and optional pressure recorder with **inductive modem interface** and internal RS-232 serial interface.

SBE Data Processing – Win 2000/XP data processing software, which calculates and plots temperature, pressure, and derived variables. The only modules in SBE Data Processing that can be used with SBE 39-IM .cnv data are ASCII Out and SeaPlot.

Scan – One data sample containing temperature, optional pressure, and date and time.

SEASOFT V2 – Complete Win 2000/XP software package, which includes software for communication, real-time data acquisition, and data analysis and display. SEASOFT V2 includes *Deployment Endurance Calculator*, *SEATERM*, *SBE Data Processing*, and *Plot39*.

SEATERM – Win 95/98/NT/2000/XP terminal program used to communicate with the 39-IM.

SIM – Surface Inductive Modem PCB, used to interface between the computer serial port and 39-IM or other compatible IM instruments. Either an IMM or SIM is required to interface with the 39-IM.

Appendix I: Functional Description

Sensors

The SBE 39-IM includes the same temperature sensor element (pressure-protected thermistor) previously employed in the modular SBE 3 sensor, in the SEACAT family, and in the SBE 39 with RS-232 interface.

Note:

Pressure ranges are expressed in meters of deployment depth capability.

The 39-IM's optional pressure sensor, developed by Druck, Inc., has a superior design that is entirely different from conventional 'silicon' types in which the deflection of a metallic diaphragm is detected by epoxy-bonded silicon strain gauges. The Druck sensor employs a micro-machined *silicon diaphragm* into which the strain elements are implanted using semiconductor fabrication techniques. Unlike metal diaphragms, silicon's crystal structure is perfectly elastic, so the sensor is essentially free of pressure hysteresis. Compensation of the temperature influence on pressure offset and scale is performed by the 39-IM's CPU. The pressure sensor is available in the following pressure ranges: 20, 100, 350, 600, 1000, 2000, 3500, and 7000 meters.

Sensor Interface

Temperature is acquired by applying an AC excitation to a hermetically sealed VISHAY reference resistor and an ultra-stable aged thermistor with a drift rate of less than 0.002°C per year. A 24-bit A/D converter digitizes the outputs of the reference resistor and thermistor (and optional pressure sensor). AC excitation and ratiometric comparison using a common processing channel avoids errors caused by parasitic thermocouples, offset voltages, leakage currents, and reference errors.

Real-Time Clock

To minimize battery current drain, a low power *watch* crystal is used as the real-time-clock frequency source. The sensitivity of the clock to ambient temperature is accurately measured during calibration. The results are stored in EEPROM and automatically applied during deployment.

Memory

Data

The 39-IM has a 64 MB FLASH memory for data storage (32 MB usable space in memory). FLASH memory is non-volatile, and data in the memory is not lost as a result of depletion or removal of the batteries. Because FLASH is written to a *page* (256 bytes) at a time, data is first accumulated in a 256-byte cache buffer. When the cache is full, its contents are transferred to FLASH memory. The cache is volatile, and thus depends on battery power. That is why a 39-IM with depleted batteries will lose its most recently stored data unless an external battery is used (see *Uploading Data* in *Section 4: Deploying and Operating SBE 39-IM*).

The data upload process integrates data from the FLASH memory and the cache. **#iiSampleNum=** controls the memory pointers that manage this process. Setting **#iiSampleNum=0** resets the pointer in the FLASH memory and in the cache memory, causing the 39-IM to overwrite existing data. It is important not to change **#iiSampleNum=** until all data has been uploaded.

If **#iiSampleNum=** is inadvertently set to 0 before data is uploaded, and you wish to upload data, the following conditions apply:

Was additional data logged after #iiSampleNum= was changed?	User then returns #iiSampleNum= to:	Description of Uploaded Data
No	Original value	All data (data in FLASH as well as data in cache) uploads correctly.
No	Estimated value larger than original value	All data in FLASH uploads correctly. Data in cache is corrupted (minimum of 0 and maximum of 36 scans).
Yes < 256 bytes of new data (36 scans of T & time; 23 scans of T, P, & time)	Original value	Old data in FLASH uploads correctly. Old data in cache is corrupted. First scan of new data in cache is corrupted; remaining scans of new data in cache upload correctly.
Yes >256 bytes of new data (36 scans of T & time; 23 scans of T, P, & time)	Original value	Old data in FLASH is overwritten with new data. Old data in cache is corrupted. If new data set is smaller than old set, a portion of old set can be recovered; scan bridging old and new data is corrupted. First scan of new data in cache is corrupted; remaining scans of new data in cache upload correctly.

T= temperature, P= pressure

Timekeeping

Time is stored in volatile memory. If power is removed, the clock resets to 1 January 1980. Upon restoration of power, the clock resumes normal operation.

Settings

Calibration coefficients and setup and operating parameters (**#iiInterval=**, **#iiSampleNum=**, etc.) are written to EEPROM and are non-volatile. These settings do not change if power is removed.

Appendix II: Plot39 Data Plotting Program

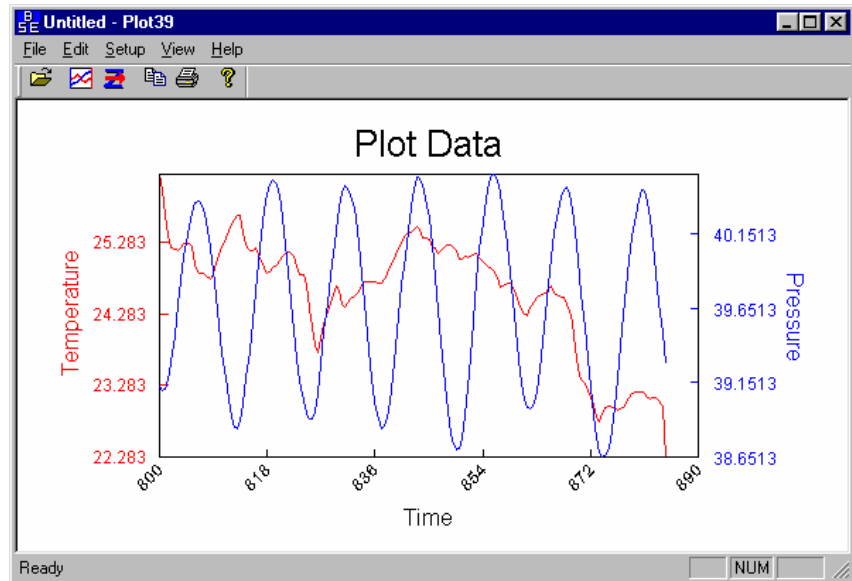

Note:

Help files provide detailed information on the use of Plot39.

Plot39 is used to plot ASCII data (.asc file) that has been uploaded from the 39-IM. Plot39:

- Plots the data in color. The plot can be saved as a graphic file for presentation.
- Improves display speed with data culling. Plot39 plots every Nth data value, where N is dependent on the number of data values to be displayed and the width of the display rectangle in pixels.
- Allows axis and font sizes to be easily changed.
- Allows a section of a plot to be magnified to reveal more detail.

If not already installed, install Plot39 and other Sea-Bird software programs on your computer using the supplied software CD (see *Software Installation in Section 3: Preparing SBE 39-IM for Deployment*).

Appendix III: Command Summary

Note:

See *Command Descriptions* in *Section 4: Deploying and Operating SBE 39-IM* for detailed information and examples.

FUNCTION	CATEGORY	COMMAND	DESCRIPTION
SIM Commands	-	PwrOn	Send wakeup tone to all IMs.
		PwrOff	Send power off command to all IMs. IMs enter quiescent (sleep) state. Main power turned off, but data logging and memory retention unaffected.
		DS	Display SIM firmware version and status.
		Baud=x	x = baud rate between SIM and computer/controller (1200, 2400, 4800, or 9600). Default 9600.
		DataNNMax=x	x = timeout (0-32767 msec) that applies to !iiData and Dataii only. If no reply received within DataNNMax =, control returned to computer and other commands can be sent. Default 1000 msec.
		RelayMax=x	x = timeout (0-3276 sec) that applies to all other commands. If no reply received within RelayMax =, control returned to computer and other commands can be sent. Default 20 sec.
		EchoOn	Echo characters received from computer (default).
		EchoOff	Do not echo characters received from computer.
		AutoPwrOn=x	x=Y (default): Automatically send PwrOn to IMs when power applied to SIM. This wakes up all IMs on-line. x=N : Do not send PwrOn when power applied to SIM.

FUNCTION	CATEGORY	COMMAND	DESCRIPTION
39-IM Communication Microcontroller Commands (ii = 39-IM ID)	Status	!iiDS	Display status and setup parameters.
		!iiGetSD	Display status data.
		!iiGetCD	Display configuration data.
		!iiGetHD	Display hardware data.
		!iiGetHostID	Display host ID.
	ID	ID?	Get IM ID (0-99).
		*ID=ii (only 1 IM can be on line or all will have same ID)	Set IM ID to ii (0–99). Must be sent twice, because verification requested.
		!iiSetDeviceID=nn	nn= new instrument ID (ii= old instrument ID).
		!Sx:SetDeviceID=nn	nn= new instrument ID (x= instrument serial number).
		!iiSetHostID=x	x= host ID (4 – 64 character string).
		Setup	!iiSetLowPwrTx
	!iiSetFullPwrTx		Set 39-IM’s transmitter voltage to maximum signal strength.
	!iiSetGDataStr=x		x= string (2 to 16 characters) sent to 39-IM acquisition microcontroller when GData command is received by communication microcontroller. String is one of these: GetAvgRestart (default), StartNow , ResumeLogging , StartInterval , GetAvg , GetLastRestart , GetLast , or GetNew .
	!iiSetGroupNumber=x		x= 39-IM group number.
	!iiStayOn		Command 39-IM to reset counting for 2-minute timeout.
	Global		MMDDYY=mmddy
		DDMMYY=ddmmyy	Set real-time clock day, month, year for all IMs. Must follow with HHMMSS= or it will not set date.
		HHMMSS=hmmss	Set real-time clock hour, minute, second for all IMs.
		GData	Simultaneously command all IM communication microcontrollers to send command defined by !iiSetGDataStr= to acquisition units. IM communication microcontrollers hold data in a buffer until receiving !iiData , Dataii , or !iiGetReply .
		StayOn	Command all IMs to reset counting for 2-minute timeout.
	Get Data	!iiGData	Command 39-IM communication microcontroller to send command string defined by !iiSetGDataStr= to acquisition microcontrollers. Acquisition microcontroller transmits data (last sample or average, depending on command string) to communication microcontroller, which holds data in buffer until receiving !iiData , Dataii , or !iiGetReply .
		!iiData	Get data in buffer, obtained with GData , from IM with ID= ii .
		Dataii	Same as !iiData .
		!iiGetReply	Same as !iiData .

FUNCTION	CATEGORY	COMMAND	DESCRIPTION
<i>Continued . . .</i> 39-IM Communication Microcontroller Commands (ii = 39-IM ID)	Diagnostics	!iiEchoIMx	x = string (24 characters maximum, letter and numbers only) to be echoed back to IMM/SIM.
		!iiTxText	Test line conditions. Test includes: <ul style="list-style-type: none"> • 10 seconds of silence • Transmission of upper case letter <i>U</i> 250 times • Transmission of upper case letter <i>U</i> 250 times, with varied time intervals between each letter
		!iiTestCableCoupler	Test cable coupler in 39-IM.
		!iiGetEventCounters or !iiGetEC	Transmit list of <i>events</i> and number of times they occurred. Events can be unexpected conditions which should be interpreted as errors as well as device power-up, invalid commands, or low-battery conditions.
		!iiResetEventCounters or !iiResetEC	Clear event counters to 0.
39-IM Acquisition Microcontroller Commands (ii = 39-IM ID)	Status	#iiDS	Display status and setup parameters.
	Setup	#iiDateTime= mmddyyyyhhmmss	Set real-time clock month, day, year, hour, minute, second.
		#iiMMDDYY=mmddy	Set real-time clock month, day, year. Must follow with #iiHHMMSS=.
		#iiDDMMYY=ddmmyy	Set real-time clock day, month, year. Must follow with #iiHHMMSS=.
		#iiHHMMSS=hhmmss	Set real-time clock hour, minute, second.
		#iiTxSampleNum=x	x=Y : Output six-character sample number with data from !iiData , Dataii , or !iiGetReply . x=N : Do not output sample number.
		#iiFormat=x	x=0 or 1 (default): Date format for converted data dd mmm yyyy. x=2 : Date format for converted data mm-dd-yyyy.
		#iiQS	Only accepted in Serial mode. Enter quiescent (sleep) state. Main power turned off; data logging and memory retention unaffected.

FUNCTION	CATEGORY	COMMAND	DESCRIPTION
Continued . . . 39-IM Acquisition Microcontroller Commands (ii = 39-IM ID)	Autonomous Sampling (Logging)	#iiInterval=x	x= interval (10 - 30000 sec) between samples. When commanded to start sampling, 39-IM takes sample, stores data in FLASH memory, and powers down at x sec intervals.
		#iiInitLogging	After all data uploaded, send this before starting to log to make entire memory available for recording. If not sent, data stored after last sample. Equivalent to #iiSampleNum=0 .
		#iiSampleNum=x	x= sample number for first sample when logging begins. After all data has been uploaded, set to 0 before starting to log to make entire memory available for recording. If not set to 0, data stored after last sample. If set to 0, equivalent to #iiInitLogging .
		#iiStartNow	Start logging in 10 sec.
		#iiResumeLogging or #iiStartInterval	Start logging in #iiInterval sec.
		#iiStartDateTime= mmddyyhhmmss	Delayed logging start: month, day, year, hour, minute, second.
		#iiStartMMDDYY= mmddy	Delayed logging start: month, day, year. Must follow with #iiStartHHMMSS= .
		#iiStartDDMMYY= ddmmyy	Delayed logging start: day, month, year. Must follow with #iiStartHHMMSS= .
		#iiStartHHMMSS= hhmmss	Delayed logging start: hour, minute, second.
		#iiStartLater	Start logging at delayed logging start time.
		#iiGetAvgRestart	Get and transmit average data, (re)start logging in (#iiInterval / 2) sec, and start next averaging cycle.
		#iiGetAvg	Get and transmit average data and start next averaging cycle. Unlike #iiGetAvgRestart , this command does not reset logging time base.
		#iiGetLastRestart	Get and transmit last data, and (re)start logging in (#iiInterval / 2) sec.
		#iiGetLast	Get and transmit last data. Unlike #iiGetLastRestart , this command does not reset logging time base.
		#iiGetNew	Get (take) and transmit new sample. Data is not stored in FLASH memory.
#iiStop	Stop logging or waiting to start logging. Press Connect on Toolbar to get S> prompt before entering #iiStop . Must send #iiStop before uploading data.		

FUNCTION	CATEGORY	COMMAND	DESCRIPTION	
<i>Continued . . .</i>	Polled Sampling	#iiTS	Take sample and output converted data. Data not stored in FLASH memory.	
		#iiTSR	Take sample and output raw data. Data not stored in FLASH memory.	
		#iiTSS	Take sample, store in FLASH memory , and output converted data.	
		#iiSLT	Output converted data from last sample from buffer, and then take a new sample. Data not stored in FLASH memory.	
		#iiSLTR	Output raw data from last sample from buffer, and then take new sample. Data not stored in FLASH memory.	
		#iiSL	Output converted data from last sample from buffer.	
	Data Upload	#iiDDb,e	Upload data in ASCII from scan b to e . Send #iiStop before sending #iiDDb,e .	
		#iiDNx	Upload last x scans from memory. Do not need to send #iiStop before sending #iiDNx . Maximum of 250 samples can be uploaded at one time.	
		DB,n,b,e	Available only when connected to internal RS-232 connector. Upload data in binary at baud n from scan b to e . Send Stop before sending DB,n,b,e .	
		#ii*DB	Display binary upload parameters.	
	Testing	#iiSS	Send averaged raw data.	
		#iiTT	Measure temperature for 100 samples, output converted data (°C).	
		#iiTP	Measure pressure for 100 samples, output converted data (dbars).	
		#iiTTR	Measure temperature for 100 samples, output raw data	
		#iiTPR	Measure pressure for 100 samples, output raw data.	
	<i>Continued . . .</i>	Coefficients (F=floating point number; S=string with no spaces) Dates shown are when calibrations were performed. Calibration coefficients are initially factory-set and should agree with Calibration Certificates shipped with 39-IMs.	#iiDC	Display calibration coefficients; all coefficients and dates listed below are included in display. Use individual commands below to modify a particular coefficient or date.
			#iiTCalDate=S	S=Temperature calibration date.
			#iiTA0=F	F=Temperature A0.
#iiTA1=F			F=Temperature A1.	
#iiTA2=F			F=Temperature A2.	
#iiTA3=F			F=Temperature A3.	
#iiPCalDate=S			S=Pressure calibration date.	
#iiPA0=F			F=Pressure A0.	
#iiPA1=F			F=Pressure A1.	
#iiPA2=F			F=Pressure A2.	
#iiPTHA0=F			F=Thermistor coefficient A0.	
#iiPTHA1=F			F=Thermistor coefficient A1.	
#iiPTHA2=F			F=Thermistor coefficient A2.	
#iiPTCA0=F			F=Pressure ptca0.	
#iiPTCA1=F			F=Pressure ptca1.	
#iiPTCA2=F			F=Pressure ptca2.	
#iiPTCB0=F			F=Pressure ptcb0.	
#iiPTCB1=F			F=Pressure ptcb1.	
#iiPTCB2=F	F=Pressure ptcb2.			
#iiPOffset=F	F=Pressure offset (dbars).			

Note:
Use Upload on the Toolbar or Upload Data in the Data menu to upload data that will be processed by SBE Data Processing. Manually entering the data upload command does not produce data with the required header information for processing by SBE Data Processing.

Appendix IV: SIM Hookup and Configuration

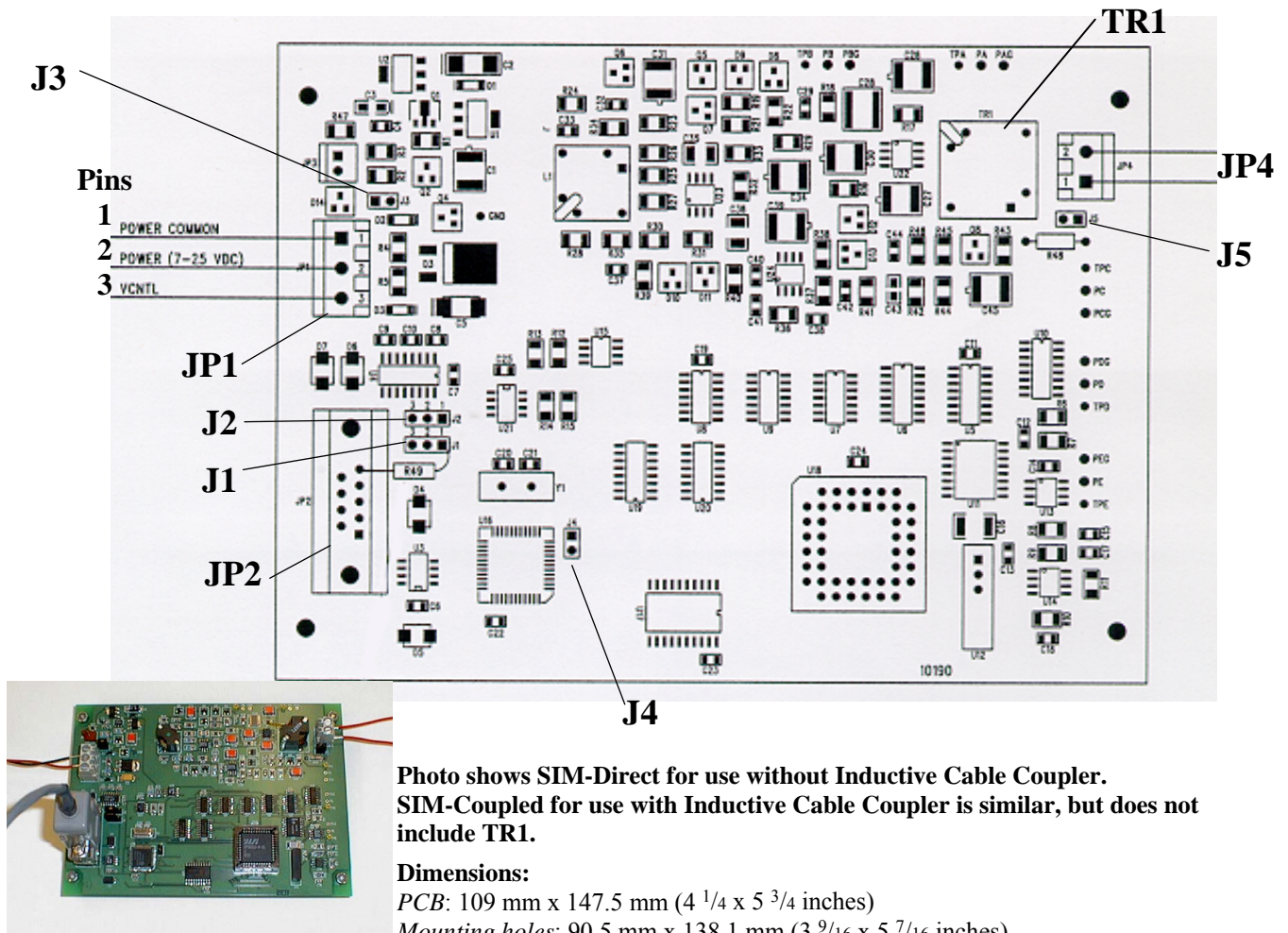

Power Connection

The SIM can be configured to power up in either of the following two modes:

- **Normal Power Switching (factory setting)** – The SIM runs when power is applied. Set up the SIM as follows:
 1. Connect Power Common to JP1 pin 1.
 2. Connect 7-25 VDC to JP1 pin 2.
 3. Verify there is no connection to JP1 pin 3.
 4. Verify jumper is across J3.
- **Logic Level Controlled Power Switching** – Power is always applied to JP1, pins 1 and 2. Voltage applied to JP1 pin 3 (VCNTL) switches power to the SIM. Set up the SIM as follows:
 1. Connect Power Common to JP1 pin 1.
 2. Connect 7-25 VDC to JP1 pin 2.
 3. Remove jumper on J3.

Note:

If VCNTL < 1 volt, SIM is Off (consuming < 100 microamps).
 If VCNTL > 2 volts, SIM is On.

Interface Option Connection (J1, J2, and J4)

The SIM can be configured to accept RS-232 or RS-485:

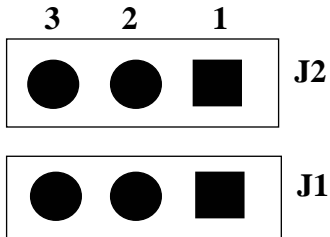

- **RS-232 (factory setting)**
 1. Verify jumper is on J1 pins 2 and 3.
 2. Verify jumper is on J2 pins 2 and 3.
 3. Remove jumper on J4.
- **RS-485**
 1. Install jumper on J1 pins 1 and 2.
 2. Install jumper on J2 pins 1 and 2.
 3. Install jumper on J4.

I/O Connector Wiring (JP2)

Connect wires to JP2 as follows:

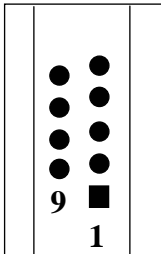

- **RS-232**
 1. **Pin 2** – RS-232 transmit from SIM to computer
 2. **Pin 3** – RS-232 transmit from computer to SIM
 3. **Pin 5** – Power Common
- **RS-485**
 1. **Pin 4** – RS-485 ‘A’
 2. **Pin 5** – Power Common
 3. **Pin 6** – RS-485 ‘B’

Inductive Mooring Cable Connection (JP4)

Note:

ICC version 4 may have 3 wires in the cable. If you ordered the ICC with a pigtail termination, solder the white and white/black wires together and attach to 1 terminal of JP4. Attach the white/red wire to the other terminal.

- **IM instruments installed with Inductive Cable Coupler (ICC)** - Connect wires from the ICC to JP4 on SIM-Coupled.
- **IM instruments installed without Inductive Cable Coupler** - Connect wires from the mooring cable and seawater ground to JP4 on SIM-Direct.

Normal Deployed Operation (J5)

- **Normal Deployed Operation** – Ensure jumper on J5 is installed.
- **Instrument Setup and Lab Testing** - Remove jumper on J5. Removing the jumper on J5 inserts a 1K resistor in series with the inductive loop, reducing the signal amplitude. This prevents the IM instruments in close proximity from responding to commands, which is especially important when sending ***ID=**.

Appendix V: Replacement Parts

Part Number	Part	Application Description	Quantity in 39-IM
22095	Battery, 3.6-volt AA lithium, Saft LS14500	Power 39-IM	2
233062	Plastic temperature sensor guard	Screws to end cap to protect temperature sensor for 39-IM with external thermistor	1
50382	Cable clamp kit for ¼ inch cable	Complete kit, including: <ul style="list-style-type: none"> mooring clamp (tightens around housing) with matching cable clamp (attaches to mooring clamp), bolts, washers, and o-rings, and inserts to convert an existing modem end cap clamp assembly to a different size 	1
50383	Cable clamp kit for 5/16 inch or 8 mm cable		
50384	Cable clamp kit for 3/8 inch cable		
50385	Cable clamp kit for 1/2 inch cable		
50386	Cable clamp kit for 5/8 inch or 16 mm cable		
50387	Cable clamp kit for 6 mm cable		
50388	Cable clamp kit for 10 mm cable		
50389	Cable clamp kit for 12 mm cable		
801579	6-pin DF3 to 9-pin DB-9S I/O cable, 0.3 m (1ft) long	From internal RS-232 connector to computer	1
171887	9-pin DB-9P to 9-pin DB-9S I/O cable, 3 m (10 ft) long	From SIM to computer	-
801583	10-pin DF11 to 9-pin DB-9S and battery snap	From IMM to computer and power supply	-
171888	25-pin DB-25S to 9-pin DB-9P cable adapter	For use with computer with DB-25 connector	1
60044	Spares kit	Includes: <ul style="list-style-type: none"> 31274 Parker O-ring, 2-029 E603-70 (sensor end cap seal) 60039 desiccant bags in metal can (25 1-gram bags and 1 humidity indicator card, for replacing electronics' desiccant each time you open housing) 	-
31875	O-ring, Parker, 2-134, E-603-70	Secures battery cover over batteries	1
233225	Fairing / net fender	For protection from snagging by nets and fishing lines	-

Index

B

Batteries · 10, 50
 endurance · 13
 replacing · 63
 shipping precautions · 7
 Battery endurance · 9, 17

C

Calibration · 65
 Clock · 10, 69
 Command summary · 72
 Commands
 autonomous sampling · 41
 coefficients · 48
 communication microcontroller status · 32
 data upload · 45
 descriptions · 30
 echo · 31
 get data · 37
 global · 36
 ID · 34
 logging · 41
 polled sampling · 44
 power on/off · 31
 SBE 39-IM acquisition microcontroller · 39
 SBE 39-IM communication microcontroller · 32
 setup · 35, 40
 SIM firmware version · 31
 status · 39
 Surface Inductive Modem · 31
 testing · 47
 timeout · 31
 Communication defaults · 22
 Convert .asc to .cnv · 62
 Corrosion precautions · 63

D

Data output formats · 49
 Data plotting · 71
 Data processing · 9, 62
 installation · 17
 Deployment
 installation · 51
 preparing for · 17
 setup · 50
 Deployment Endurance Calculator · 9, 17
 Description · 8
 Desiccant · 63
 Dimensions · 11

F

Fairing · 9, 52
 Flooded instrument · 54
 Format
 data output · 49
 Functional description · 69

G

Glossary · 68

I

ICC · *See* Inductive Cable Coupler
 ID
 setting · 18
 IMM · *See* Inductive Modem Module
 Inductive Cable Coupler · 16, 53
 Inductive Modem Module
 description · 15

L

Limited liability statement · 2

M

Maintenance · 63
 Memory · 10, 70
 Modes · *See* Sampling modes
 Mooring cable · 16

N

Net fender · 9, 52

O

Operation description · 24

P

Parts
 replacement · 79
 Plot39 · 9, 17, 62, 71
 Power
 endurance · 9, 17
 Pressure sensor
 maintenance · 65
 Processing data · 62

Q

Quick start · 5

R

Recovery
 physical handling · 54
 uploading data · 55
 Replacement parts · 79

S

Sample timing · 12
Sampling modes · 26
 autonomous · 27
 averaging · 29
 combo · 28
 polled · 26
SBE Data Processing · 9, 17, 62
SEASOFT · 9, 17
SEATERM · 9, 17, 20, 55, 59
 main screen · 20
 toolbar buttons · 21
Sensors · 10, 69
Shipping precautions · 7
SIM · *See* Surface Inductive Modem
Software · 9, 17
Software installation · 17
Specifications · 10
Surface Inductive Modem
 description · 15
 wiring · 77
System description · 8

T

Terminal program · 9, 20
 installation · 17
Testing · 18
Timeout descriptions · 25
Troubleshooting · 67

U

Unpacking SBE 39-IM · 6
Uploading data · 55
 inductive modem telemetry · 59
 RS-232 telemetry · 55
 serial mode telemetry · 55

W

Wiring · 53