



SEA-BIRD ELECTRONICS, INC.

1808 136th Place N.E., Bellevue, Washington 98005 USA

Telephone: (425) 643-9866 Telex: 292915 SBEI UR

Fax: (425) 643-9954

email: seabird@seabird.com

SBE P/N 50087 / 50087.1

DATE	SYM	REVISION RECORD	AUTH	DR	CHK
12.19.2003	B	Moved pictures to Drawing page		KLP	
5.16.2007	C	UPDATE A/F CAP WITH BARB PN	CB	CB	

Conductivity Cell Filling & Storage Device

Kit Contents

SBE P/N	Manufacturer P/N	Primary SBE Application	QTY
30384	TYGON TUBE 7/16 ID, 1/16 WALL	Interface Device to cell end	.25
30385	TYGON TUBE 1/4 ID, 1/16 WALL	Tubing for Cell filling device	1
30521	SYRINGE, 60 CC	Fill with triton solution to store cell	1
30522	UNION, REDUCING, NYLON	Interface Device to cell end	1
233538	ANTI-FOULANT DEVICE CAP w/ BARB	For use on CTDs with no cell barbs	2
30384	TYGON TUBE 7/16 ID, 1/16 WALL	For use to soak the cell with device	1

BACKGROUND

Sea-Bird recommends keeping the conductivity cell full of purified water (except in freezing environments) during periods when the CTD is not being used. This is important in keeping the cell free from contamination and in keeping the electrodes wetted and ready for immediate use.

CTDs with pumped conductivity cells (SBE 911, SBE 25 and some Seacats) are shipped with syringe and tubing assembly (P/N 50087) as an accessory for filling and storing the conductivity cell. The tubing assembly consists of a length of 1/4 inch I.D. tube connected to a short piece of 7/16 inch I.D. tube by a plastic reducing union.

REMEMBER TO REMOVE THE SYRINGE AND TUBING BEFORE DEPLOYMENT!

APPLICATIONS:

Conductivity Cell Storage and Filling Device

SBE P/N	Part Description	Primary SBE Application	QTY
30384	TYGON TUBE 7/16 ID, 1/16 WALL	Interface Device to cell end	.25
30385	TYGON TUBE 1/4 ID, 1/16 WALL	Tubing for Cell filling device	1
30521	SYRINGE, 60 CC	Fill with triton solution to store cell	1
30522	UNION, REDUCING, NYLON	Interface Device to cell end	1

1. This device can most easily be used for caged, pumped CTD arrangements
2. However, it may also be used for safely storing any type of cell.

Adapter for CTDs with no barbs on the cell ends

SBE P/N	Part Description	Primary SBE Application	QTY
233538	ANTI-FOULANT DEVICE CUP w/ BARB	For use on CTDs with no cell barbs	2

3. This adapter will allow soaker hose installation onto any cell end that has an Anti-Foulant cup attached, but does not have the barbed end installed.

Simple Soaker hose for storage of a cell without the device

SBE P/N	Part Description	Primary SBE Application	QTY
30384	TYGON TUBE 7/16 ID, 1/16 WALL	For use to soak the cell with device	1

1. Any cell that can accept the device can also accept the simple hose.
2. Use the hose when use of the device is not convenient, or not possible.

Parent Part Number: 50087 / 50087.1

Sea-Bird Electronics Procedure

PROCEDURE NUMBER: 67043

TITLE: SBE Cell Filling & Storage Device Kit

REVISION: C

EFFECTIVE DATE: 5.15.2007

CHECKED BY:

PAGE 1 of 2



SEA-BIRD ELECTRONICS, INC.

1808 136th Place N.E., Bellevue, Washington 98005 USA
Telephone: (425) 643-9866 Telex: 292915 SBEI UR
Fax: (425) 643-9954 email: seabird@seabird.com

General Cell Filling & Storage Procedure

A. FLUSHING CONDUCTIVITY CELL AFTER USE

1. Draw 40-60 cc purified water into syringe.
2. For systems with a TC Duct, remove barbed adapter, and larger tubing, and connect tubing to TC duct intake on temp sensor [Figure 1].
3. For systems without a TC Duct, connect tubing directly to open end of conductivity cell. [Figure 2]
4. Inject water into the cell and pump plumbing.

B. SYSTEM STORAGE

1. Fill syringe with fresh, de-ionized water.
2. Loop Rubber band around CTD Cage bar, or body of CTD, if no cage.
3. Connect tubing to cell or TC duct intake.
4. System may be stored this way for longer periods, provided temperatures never drop below freezing.

To Install Hose Barbs for Cleaning & Storage

A. Remove Old Caps

1. Use a 5/8 inch socket to carefully remove existing caps from the cell ends.
2. Store these caps in a safe place, along with the units, as they must be reinstalled prior to deployment.
3. Different configurations of SBE16plus/19plus may have different anti-foulant caps installed. You need only remove those caps that do not have barbs on them already.
4. If you are only removing the caps from one end of the cell, please make a note of which end that is, to insure that they are returned to the correct location later.

B. Install New Barbs

1. Use a 5/8 inch socket to carefully thread the caps onto the anti-foulant cups.
2. Make sure threads are straight, as the celcon material is very easy to cross-thread.
3. Tighten the caps just until snug. If they are tight, but are not flush to the anti-foul chamber, that is OK.

C. Remember to re-install proper caps before deployment. Using a barbed cap with unpumped CTDs is likely to produce undesirable results in your data.

Parent Part Number: 50087 / 50087.1

Sea-Bird Electronics Procedure

PROCEDURE NUMBER: **67043**

TITLE: **SBE Cell Filling & Storage Device Kit**

REVISION: **C**

EFFECTIVE DATE: **5.15.2007**

CHECKED BY:

PAGE 1 of 2

DATE	SYM	REVISION RECORD	AUTH.	DR.	CK.
12.18.03	A	ADDED FIGURE 1 & 2		KLP	

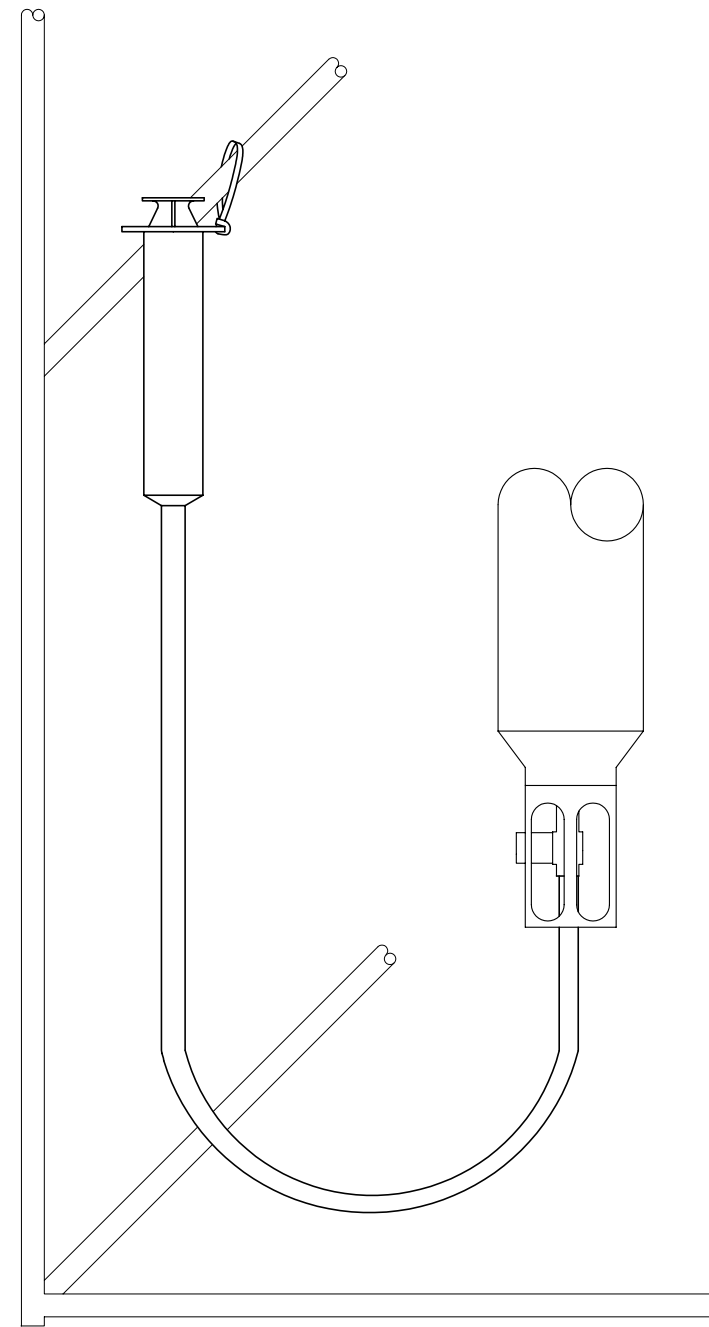
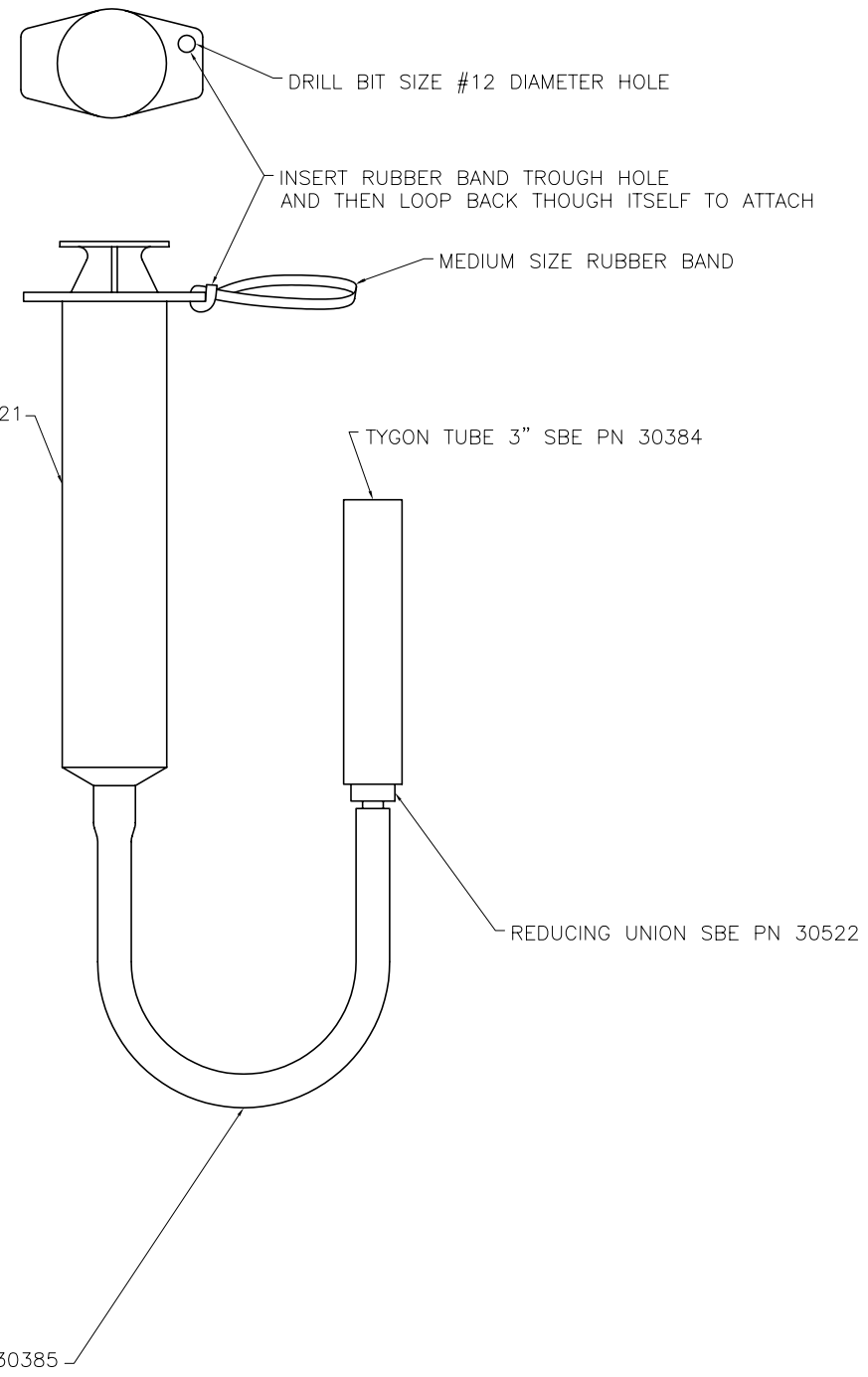

FIGURE 1

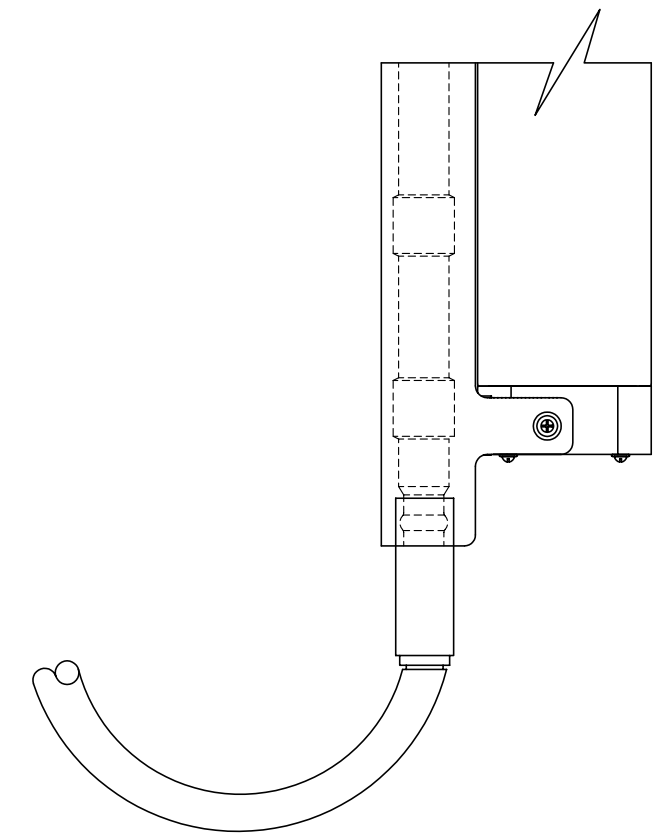

FIGURE 2

TOLERANCES	SEA-BIRD ELECTRONICS, INC				
FRACTIONAL	P/N	50087	SCALE	DRAWN BY DW	
			1:1	APPROVED BY	
DECIMAL	TITLE CONDUCTIVITY CELL FILLING & STORAGE DEVICE				
ANGULAR	DATE	DRAWING NUMBER	67043	REV A	
	6.6.98				