



# SEA-BIRD ELECTRONICS, INC.

1808 136th Place N.E., Bellevue, Washington 98005 USA  
Telephone: (425) 643-9866 Telex: 292915 SBEI UR  
Fax: (425) 643-9954 email: seabird@seabird.com

SBE P/N 801269/801270

| DATE | REV | REVISION RECORD | AUTH | DR | CHK |
|------|-----|-----------------|------|----|-----|
|      |     |                 |      |    |     |

## SBE16plus / SBE19plus CTD Cage Installation

### A. Positioning the SBE19 in the cage

1. One new feature of the Seacat plus cage is that the Seacat may be positioned into it at any spot along the horizontal bars. Where the best spot will be is determined by the configuration of the other sensors on the work order.
2. In general, attempt to keep CTDs centered in the cages, and to float all other sensors around them.
3. Current configurations will be using strap-on sensors with mount blocks for most applications, so CTDs will usually be required to have space on all sides.
4. There is no difference for installation when applying a different cage length, nor when moving the CTD back and forth along the crossbars.
5. However, a CTD may be installed into almost any location inside the cage, simply by moving the Bars, or flipping the clamp set around. The following procedure will center your CTD in side to side in the cage.

### B. Installing Seacat+ into a cage

1. After determining CTD's position, install support bars
2. Install Bar2 (231882)
  - a. Longest support bar (bar 2, PN 231882) is used to secure the connector Endcap, and is placed onto the lower crossbar pair.
  - b. Secure to cage crossbars with 2each bolts (31138) and lock washers (30254).
3. Install bars 3 and 4 (231883/231884)
  - a. Bar 4 is the shortest bar.
    - *Install bar 4 onto upper crossbar one offset from bar 1 by 1 position.*
    - *Offset is the direction toward the cell guard, as bar 1 installs onto the endcap's back.*
  - b. Bar 3 installs directly opposite of bar 4, and corresponds to the side of bar 2 which has all the screw holes.
  - c. Install SBE19 cage clamp set (23761C) onto the longer top bar (231883), using one bolt (31138), thoroughly coated in NeverSeez. Leave bolt very loose, so that parts swing freely.
    - *Larger diameter piece faces the direction that the cell guard will face.*
4. Install CTD onto clamps
  - a. Two of the four holes on 231882 should align to the Seacat clamp set. If they do not, either the clamp set or the bar will need to rotate 180°.
  - b. Fill sensor Endcap holes at least 1/2 way with DC-4
  - c. Thoroughly coat all screws with NeverSeez.
  - d. Install screw insulators (2330294) into both sides of bar 2(231882) where the bolts will go.
  - e. Secure sensor Endcap with two each of flat washers (30634), lock washers (30633), and bolts (31225).
  - f. Fit CTD into the clamp set, and secure clamp set with two each of bolts (31225) and lock washers (30254).
  - g. In general, we do not need to align the battery Endcap as we used to do for SBE16/19 CTDs.

SBE Drawings:  
75019P page 9  
SBE19plus Cage Installation Drawing

**Sea-Bird Electronics Procedure**  
PROCEDURE NUMBER: 67171  
TITLE: **SBE SeacatPlus Cage Installation**  
REVISION:  
EFFECTIVE DATE: 03/09/2006  
CHECKED BY: \_\_\_\_\_

| DATE     | SYM | REVISION RECORD     | AUTH. | DR. | CK. |
|----------|-----|---------------------|-------|-----|-----|
| 2.5.05   | C   | ADDED FINAL ASSY    |       | KLP |     |
| 4.14.05  | D   | ADDED CAGE PNS      | CB    | KLP |     |
| 11.23.05 | E   | Added Resistor pg 1 | CB    | KLP |     |
| 02.15.06 | F   | ECN900 - Svc. loops | GM    | MJ  |     |

# DETAIL 'A'

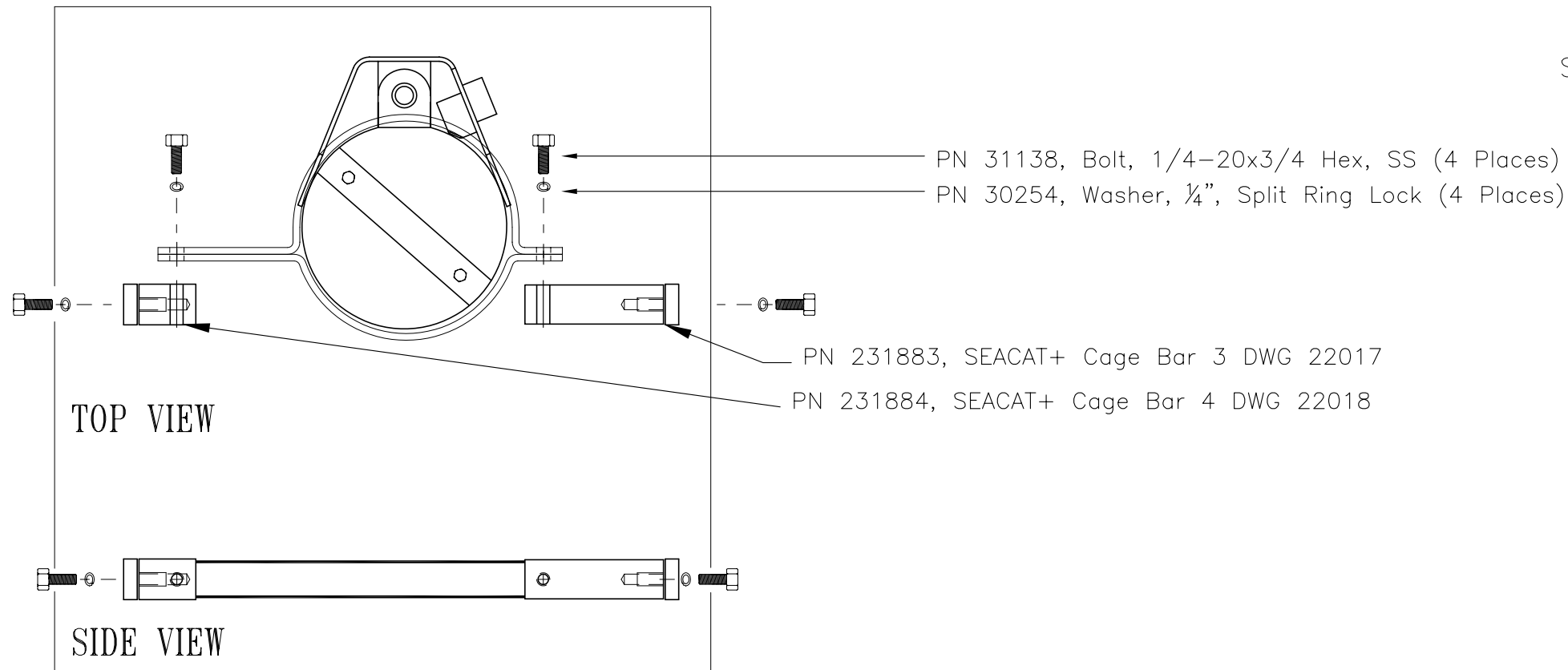

Upper crossbar pair hold the cage clamp set  
 Sensor endcap bolts directly onto lower crossbar

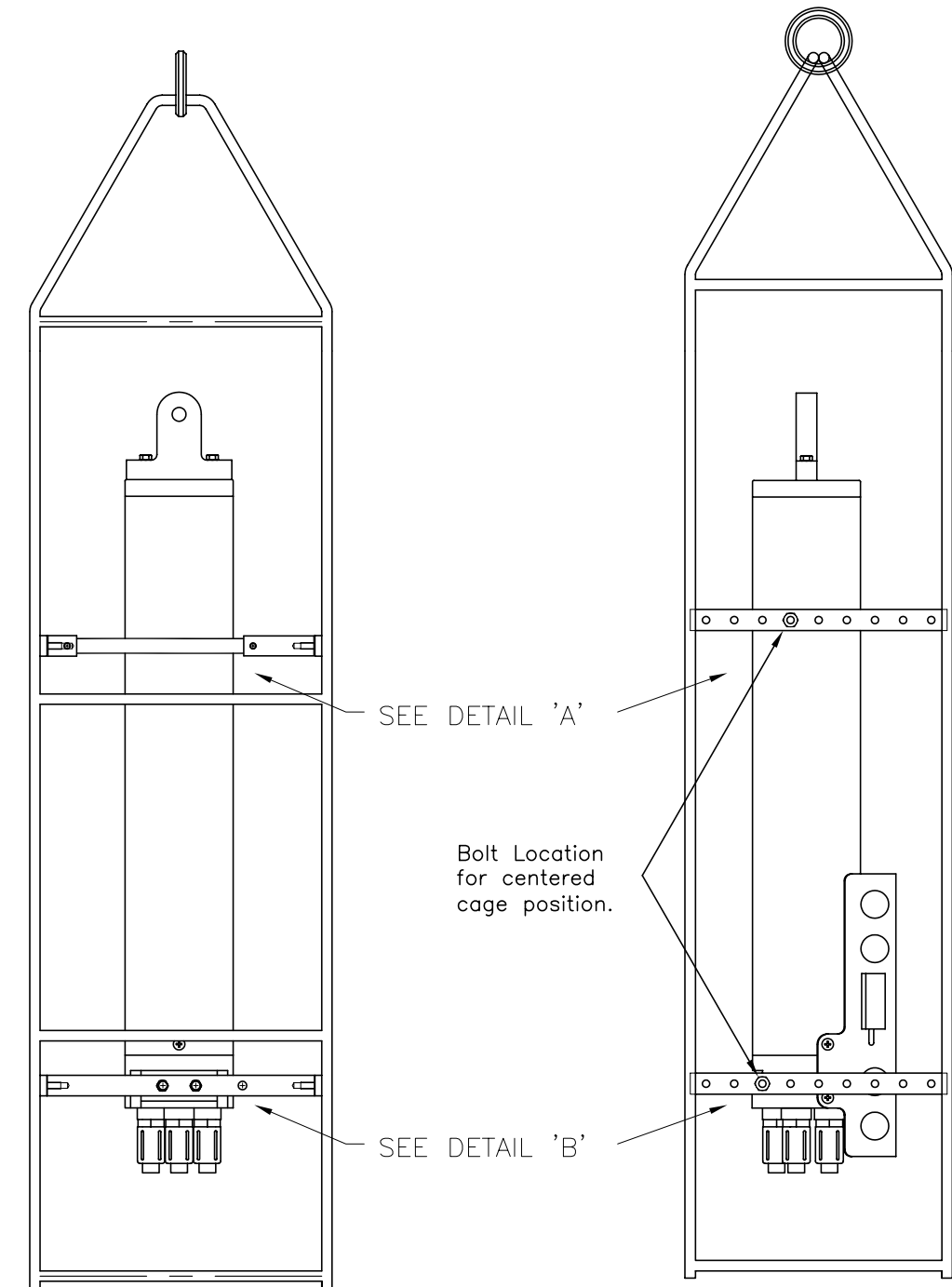

# DETAIL 'B'

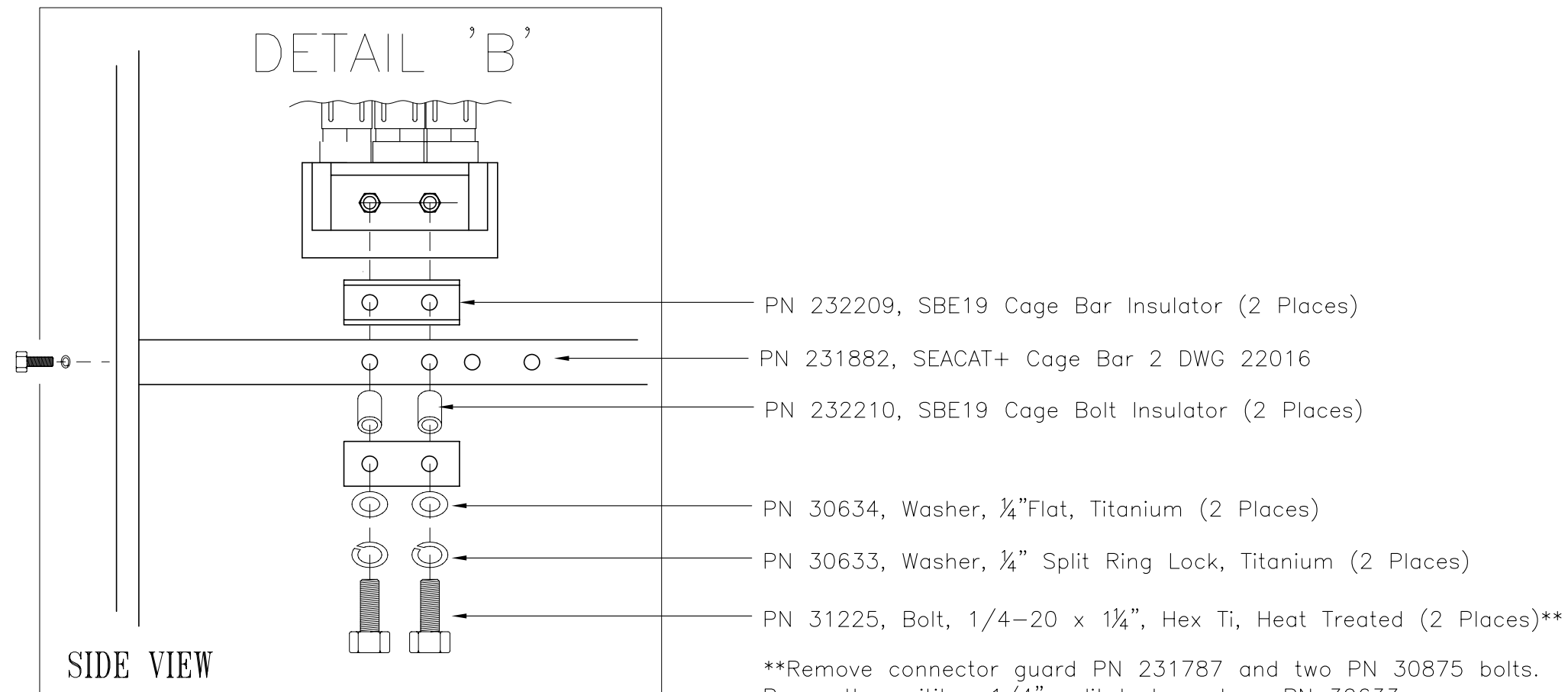

\*\*Remove connector guard PN 231787 and two PN 30875 bolts.  
 Reuse the exiting 1/4" split lock washers PN 30633

|            |   |                |        |             |  |
|------------|---|----------------|--------|-------------|--|
| TOLERANCES | SEA-BIRD ELECTRONICS, INC                                 |                |        |             |  |
| FRACTIONAL | P/N   | 90385          | SCALE  | DRAWN BY MJ |  |
|            |   |                | N.T.S. | APPROVED BY |  |
| DECIMAL    | TITLE SBE19plus FINAL ASSEMBLY<br>Final Cage Installation |                |        |             |  |
| ANGULAR    | DATE  | DRAWING NUMBER | 75019P | REV F       |  |
|            | 12.06.01  | SHEET 9 OF 9   |        |             |  |