

| DATE     | SYM | REVISION RECORD                                    | AUTH. | DR. | CK. |
|----------|-----|--|-------|-----|-----|
| 03.02    | A   | Add Adhesive Tubing                                | MJ    | CB  |     |
| 8.29.02  | B   | CHANGED LENGTH                                     | CB    | KLP |     |
| 9.23.02  | C   | ADJ. QTY , LENGTH & PN                             | CB    | KLP |     |
| 10.7.02  | D   | FIXED CONN DWG AND LS DESC                         | CB    | KLP |     |
| 10.11.02 | E   | CHANGED CABLE BREAK STRENGTH                       | CB    | KLP |     |
| 9.18.06  | F   | ECN 971 - COLOR CHANGE<br>ECN 991 - PROCESS CHANGE | CB    | MJ  |     |

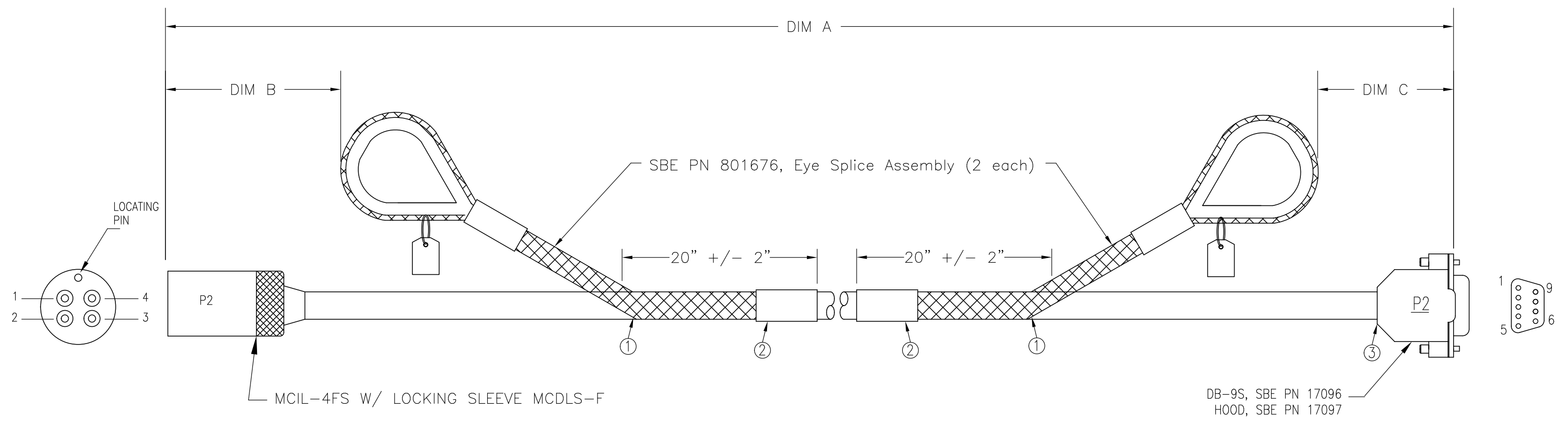

| P1 MCIL-4FS | COLOR       | ALT COLOR | P2 DB-9S |
|-------------|-------------|-----------|----------|
| PIN 1       | WHITE       | WHITE     | PIN 5    |
| PIN 2       | WHITE/BLACK | BLACK     | PIN 3    |
| PIN 3       | WHITE/RED   | RED       | PIN 2    |
| PIN 4       | --          | --        | --       |

| SBE PN | PIGTAIL | DIM A  | DIM B | DIM C |
|--------|---------|--------|-------|-------|
| 801337 | 171633  | 330 FT | 52 IN | 20 FT |
| 801338 | 171634  | 660 FT | 52 IN | 20 FT |
| 801371 | 171707  | 100 FT | 52 IN | 20 FT |
| 801372 | 171708  | 200 FT | 52 IN | 20 FT |
| 801860 | 172494  | 165 FT | 52 IN | 20 FT |
| 802028 | 172785  | 495 FT | 52 IN | 20 FT |

CABLE TYPE: FALMAT  
 SBE PN 171285, Pigtails per dwg 32642

FM020999SA1 REV. B  
 POLYURETHANE, KEVLAR REINFORCED, 3 CONDUCTOR, 22 AWG.  
 YELLOW JACKET, NOMINAL O.D. = 0.270 IN.  
 100 LBS. WORKING LOAD (45 Kg)  
 4 INCH MINIMUM BEND RADIUS (10 cm)

BRAID AND LIFT-EYE INSTALLATION

- ① BRING CABLE THROUGH BRAID  
20 +/- 2 INCHES BEHIND EYE
- ② 1/2" DIA. HEATSHRINK ADHESIVE TUBING 3", PN 31568
- ③ INSTALL CONNECTOR AFTER INSTALLING BRAIDED SPLICES

**SEA-BIRD ELECTRONICS, INC**

|                                     |           |         |       |             |     |
|-------------------------------------|-----------|---------|-------|-------------|-----|
| P/N                                 | SEE TABLE | SCALE   | NTS   | DRAWN BY    | MJ  |
|                                     |           |         |       | APPROVED BY |     |
| LOAD BEARING DATA CABLE<br>MCIL-4FS |           |         |       |             |     |
| DATE                                | 9.18.2006 | DWG NO. | 32643 | SHEET       | REV |
|                                     |           |         |       | 1 of 1      | F   |