

## **Module 5**

# **Miscellaneous Applications**

## Overview



Miscellaneous Applications

- Fresh water applications
- Sound velocity
- Adding navigational information to your data
- Collecting surface PAR while taking a cast
- Collecting data from instruments that are not supported by Seasave
- Adding a 9600 bps serial data stream to your 911*plus*
- Adding RS-232 serial output interface to your 911*plus*
- Thermosalinographs

In this module we will discuss somewhat less common applications. By the end of this module you should be able to:

- Operate your CTD in fresh water.
- Speak knowledgeably about techniques of measuring sound velocity.
- Add navigational information to your CTD data.
- Collect surface PAR data with your cast.
- Display data collected from instruments not supported in Seasave in a meaningful way.
- Know what options to have installed if you need to add a serial instrument to your *9plus*, or to output serial data from your *9plus*.
- Set up and operate an SBE 21 or SBE 45 thermosalinograph.

## Fresh Water Applications



### Fresh Water Applications

- Fresh water has much lower conductivity than salt water
- When conductivity sensor frequency reaches a threshold, pump is turned on after a delay time (to allow plumbing to fill with water)
- SBE 19, *19plus*, *19plus V2*, 25, and 49: conductivity threshold and pump delay time may be set by user
- SBE *9/11plus*: conductivity threshold and pump delay time is hardwired at Sea-Bird
  - **Custom** modifications are available that may be useful for controlling pump turn-on in fresh water applications

Using a CTD in fresh water requires some modification of the instrument setup for internally recording instruments or of hardware for the *9plus*. The issue is the pump turn-on signal. As delivered, Sea-Bird instruments are configured for use in saltwater. They sense the rising conductivity frequency associated with immersion in saltwater, and turn on the pump after a short delay that allows the air in the plumbing to escape.

In internally recorded instruments and the SBE 49, the user can set the pump turn-on threshold frequency. For fresh water, this should be set to 5 Hz above the frequency at zero conductivity (wet cell rinsed with deionized water). However, values closer to the zero frequency may be needed; check your data carefully to ensure the pump is turning on properly. The user can also set the pump delay time (delay *after* pump turn-on frequency is reached and before the pump turns on, allowing time for the plumbing to fill with water).

For the SBE *9plus*, Sea-Bird hardwires the pump turn-on frequency and pump delay time (60 sec). However, one of the following **custom** modifications of the *9plus* electronics may be useful for controlling pump turn-on in fresh water applications:

- Operator control via manual turn-on / turn-off of the pump from the computer keyboard, sent through the *Modem Channel* connector in the *11plus* Deck Unit.
- Automatic turn-on of the pump 60 seconds after a water contact pin (on special dummy plug that connects to JB6 on *9plus* end cap) enters the water. Automatic turn-off of the pump when water contact pin leaves the water.

## Specific Conductance

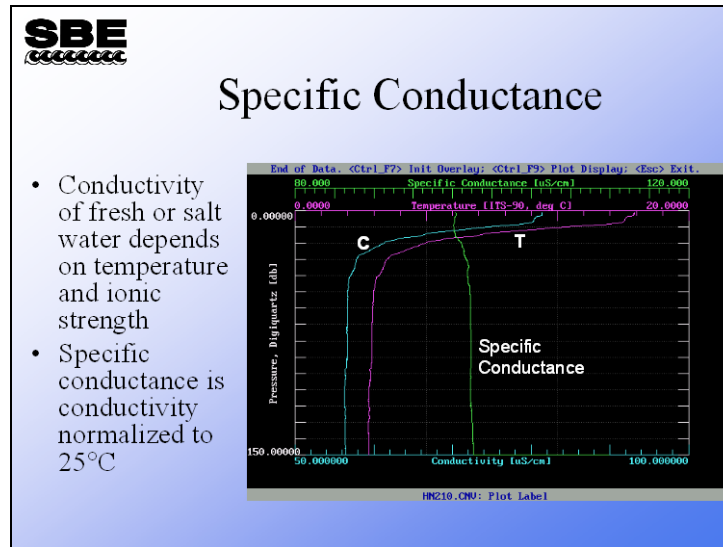

- Conductivity of fresh or salt water depends on temperature and ionic strength
- Specific conductance is conductivity normalized to 25°C

The conductivity of fresh or salt water is strongly dependent on temperature, as shown above by the similarity in the shape of the C and T plots. Specific conductance is typically used for fresh water applications, where the salinity equation is out-of-range. It allows us to visualize the conductivity without the temperature dependence, providing some indication of the amount of salts in the water.

The equation shown below has the effect of normalizing the conductivity to 25° C.

$$\text{Specific Conductance } (\mu\text{mhos} / \text{cm}) = \frac{(C \times 10,000)}{(1 + A \times (T - 25))}$$

where:

A = 0.019 to 0.020 = thermal coefficient of conductivity for natural salt ion solutions (Seasoft uses this formula with A = 0.020)

C = conductivity [S/m]

T = temperature [°C]

## Sound Velocity



### CTD and Sound Velocity

- SV +/- 0.05 m/s calculated from temperature, salinity, and pressure requires:
  - Temperature at +/- 0.028 deg C
  - Salinity at +/- 0.040 PSU
  - Pressure +/- 3 decibars
- Direct measurement of SV (with typical 20 cm path length) to +/- 0.05 m/s requires:
  - Time of flight measurement of +/- 4 nanoseconds
  - Path length maintained within +/- 0.007 mm
  - Calibration against CTDs or same references used to calibrate CTDs

Sound velocity (SV) sensors measure the flight time of a pulse of sound between transducers. To meet the  $\pm 0.05$  m/s specification of a typical 20 cm path SV sensor, the time of flight must be measured to within about 4 nanoseconds. The electronics to perform this are difficult but feasible; however, the time delays associated with the acoustic transducers cannot be maintained over pressure and temperature.

While the dependence of SV on time and distance implies that calibration is not required, in practice the distance (within necessary accuracy of  $20 \text{ cm} * [0.05 \text{ m/sec}/1500 \text{ m/sec}] = 0.0007 \text{ cm} = 0.007 \text{ mm}$ , at nominal 1500 m/s SV) cannot be established from a physical measurement of path length. This is not caused by uncertainties in mechanical dimensions; but by uncertainties in how deep into the acoustic transducer the sound pulse is when the electrical signal is generated. Accordingly, all direct SV sensors are bath-calibrated (against a CTD or the usual references used to calibrate CTDs - SPRT, Autosal, etc.).

To meet a 0.05 m/s specification, a CTD can be wrong in temperature by 0.028 °C; in salinity by 0.04 PSU; and in pressure by 3 decibars.

The linkage between CTD and SV (Chen and Millero) is part of the equation of state 1980. This international usage and recognition not only leads to the highest level of accuracy, but ensures that CTD-based SV measurements are intercomparable no matter where and when taken.

## Adding Navigational Data



### Adding Navigational Information to Your Data

- Latitude and Longitude transmitted from a GPS in NMEA format 0183 is appended to each data scan in an SBE 11*plus*, 33, or 36 Deck Unit

```

$-GGA,hhmmss.ss,llll.ll,a,yyyyy.yy,b,x,xx,x.x,x.x,M,x.x,M,x.x,xxxx*hh<CR><LF>
$-GLL,lll.ll,a,yyyyy.yy,b,hhmmss.ss,A*hh<CR><LF>
$-RMA,A,llll.ll,a,yyyyy.yy,b,x,x,x,x,x,x,x,x,a*hh<CR><LF>
$-RMC,hhmmss.ss,A,llll.ll,a,yyyyy.yy,b,x,x,x,x,ddmmyy,x,x,a*hh<CR><LF>
$-TRF,hhmmss.ss,ddmmyy,llll.ll,a,yyyyy.yy,b,x,x,x,x,x,x,xxx,A*hh<CR><LF>

```

NMEA = National Marine Electronic Association.

In Seasave, navigational data transmitted in NMEA format 0183 is appended to real-time data if you select *NMEA position data added* in the instrument configuration (.con or .xmlcon) file dialog box. Navigational data is also added to the file header at the start of the cast. And, navigational data can be written to a separate .nav file at user-selected points in the cast.

A NMEA interface is available in all Sea-Bird deck units – SBE 11*plus*, 33, and 36. The *Seacat/Sealogger RS-232 and Navigation Interface Box* (sometimes called NMEA Interface Box or Opto-Box), used with internally recording instruments or the SBE 21 thermosalinograph, also has a NMEA interface. The NMEA interface in these deck units / interface boxes require data in one of the formats shown above. In addition, the NMEA data must meet the specific baud, data bits, and parity requirements of the deck unit / interface box (see deck unit / interface box manual).

Recent changes to Seasave allow acquisition of data from a NMEA device connected directly to the computer (instead of to a deck unit / interface box) for many of our instruments. The selection of connection via computer or deck unit / interface box is made in the instrument configuration file. Seasave appends the NMEA data to the CTD data stream in the same way, regardless of which acquisition method was used.

## Adding Surface PAR



### Collecting Surface PAR

- The SBE 11*plus*, 33 or 36 will sample a PAR (Photosynthetically Active Radiation) sensor that is on the ship, for comparison with a PAR sensor mounted on the instrument package
- Each sample is appended to a data scan from the CTD

Sea-Bird deck units may be equipped with an A/D interface intended to digitize the signal from a deck-mounted PAR sensor. This is standard equipment for the SBE 11*plus* and optional for the SBE 33 and 36. In Seasave, Surface PAR data is appended to real-time data if you select *Surface PAR voltage added* in the instrument configuration (.con or .xmlcon) file dialog box.

Mount the Surface PAR sensor where it will not be shadowed by anything overhead. The Surface PAR sensor is used in conjunction with a PAR sensor mounted on the instrument package.

## Supporting Custom Auxiliary Sensors



Supporting Custom  
Auxiliary Sensors

- Seasave provides *User Poly* equations, so you can enter coefficients for a polynomial to calculate a value from the A/D conversion made by the CTD

For instruments that are not supported in Seasave, a meaningful display of data can be made by specifying a *user polynomial* to be applied to the 0 – 5V data. The user polynomial can be up to 3<sup>rd</sup> order:

$$\text{Val} = a0 + (a1 * V) + (a2 * V^2) + (a3 * V^3)$$

*where:*

V = voltage from sensor

a0, a1, a2, and a3 = user-defined sensor polynomial coefficients, specified in the instrument configuration (.con or .xmlcon) file



---

## Adding 9600 Baud Data Channel to 911*plus*



### Adding a 9600 Baud Data Channel to a 9/11*plus*

- A 9600 Baud data channel can be multiplexed into the 9*plus* data stream
- This data channel is an uplink only
- Commands may be sent down via water sampler channel
- Designed for multi-channel spectrometers
- May be used by any serial instrument
- Data is broken out separately at 11*plus*

As optional equipment, a 9600-baud serial channel can be multiplexed into the 9*plus* data stream, allowing external instruments that transmit serial data at 9600 baud or less to send their data up the sea cable. This data channel was designed for multi-channel spectrometers; however, it has also been used with acoustic Doppler current meters.

The 9600 baud channel can also be used with an instrument that transmits at 19200 baud in *burst* mode, so that the overall rate of transmission does not exceed 9600 baud.

## Adding RS-232 Serial Output Interface to 911*plus*



Adding RS-232 Serial Output Interface to a 911*plus*

- Typically used for an AUV / ROV logging 9*plus* data
- 9*plus* transmits serial data through 3-pin JT4 connector on top end cap at 19,200 baud, 8 data bits, no parity
- Power can be supplied to 9*plus* through same connector
- Data output duplicates output from 11*plus* Deck Unit, **except** averaging and alignment must be done in post-processing

As an option, an RS-232 Serial Output interface can be installed in the 9*plus*, in place of the interface for the G.O. 1015 Rosette.

## Thermosalinographs

**SBE**  
Thermosalinographs

- SBE 21 and SBE 45
- Thermosalinographs are used aboard ships to map sea surface parameters



Thermosalinographs are used to collect information about the sea surface; typically in flow-through systems operating continuously throughout a cruise. They are included in the profiling section of the course because they are installed on many research vessels. Thermosalinographs are typically installed inside and near to the hull of a ship in order to make measurements on uncontaminated seawater. Optionally, you can plumb other types of sensors into the system for a wider range of measurements.

## Thermosalinographs (*continued*)



### SBE 21 and SBE 45

- SBE 21
  - Storage in 64 MB internal memory
  - Sampling continuous (4 Hz) or 3 second – 10 minute intervals
  - Remote temperature port
  - Supports four 0 – 5V auxiliary instruments
    - Fluorometer, dissolved oxygen, pH, turbidity, etc.
  - Data transmission to remote computer via *Seacat/Sealogger RS-232 & Navigation Interface Box*
  - Navigational input via NMEA 0183 interface in Interface Box
- SBE 45
  - No memory or external sensors
  - Flexible sampling protocols
  - Remote temperature and/or NMEA 0183 navigational input via optional *SBE 45 Power, Navigation, & Remote Temperature Interface Box*

The SBE 21 is the more capable of Sea-Bird's thermosalinograph offerings, supporting a variety of auxiliary sensors and a remote temperature sensor, which is used when the thermosalinograph cannot be mounted close to the sea water inlet. The remote sensor allows a temperature measurement to be made on water that has not been warmed or cooled by a long trip through a pipe. Salinity, of course, does not change with temperature, so the conductivity measurement is valid even though the water may have changed temperature on its journey to the thermosalinograph. The SBE 21 also comes with an Interface Box, which accepts navigational data and appends the data to the SBE 21's data stream.

The SBE 45 does not have the capability to directly integrate remote temperature or navigational data. However, the SBE 45 can be used with an optional Interface Box, which accepts remote temperature and navigational data, and appends the data to the SBE 45's data stream.

## Thermosalinographs (*continued*)

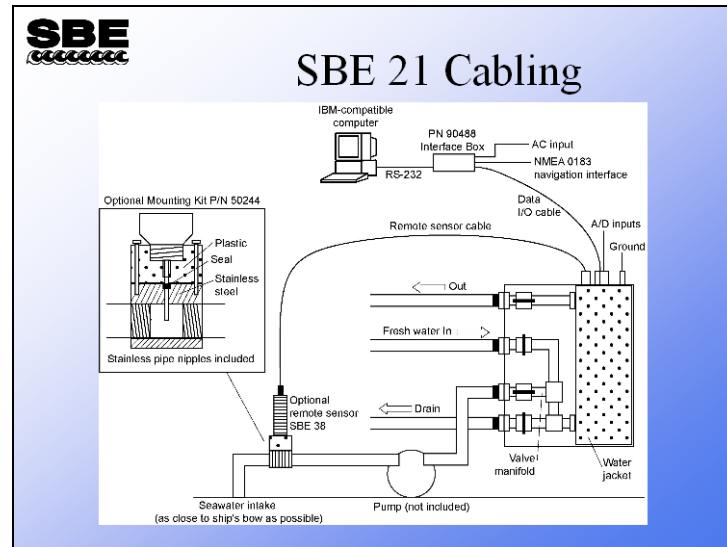

If you want to include navigational (GPS) information in your thermosalinograph data record, you will have to use a *PN 90488 Seacat/Sealogger RS-232 and Navigation Interface Box* (sometimes called an *Opto-Box* or *NMEA Interface Box*) and log your data with Seasave. The GPS data is very useful for mapping sea surface conditions. The *Interface Box* provides power and melds the SBE 21 data with the GPS data. Because the GPS data cannot be input directly to the SBE 21, you must devote a computer to data collection via Seasave.

What about that optional remote temperature sensor? Remember that salinity is independent of temperature; water that is 35 psu at 25 °C will also be 35 psu at 10 °C if there is no condensation or evaporation. So, the temperature and conductivity measurements on the water that arrives at the thermosalinograph will provide the correct salinity values, regardless of whether the water has been warmed or cooled in transit through the plumbing. However, if you are interested in the temperature of the water, use the remote temperature sensor data. And, if you want to calculate density or sound velocity (both a function of temperature and salinity), use the remote temperature sensor data with the salinity data from the thermosalinograph.

## Thermosalinographs (*continued*)



### SBE 21 Setup and Memory Endurance

- Use terminal program to:
  - Set time and date, and external sensors to log
  - Set sampling scheme and sample interval – continuous at 4 Hz (averaging every *sample interval* seconds) or 1 sample every *sample interval* seconds
  - Begin sampling with **GL** command
- Capture data with terminal program or view it with Seasave
- SBE 21 comes with 64 Mbytes of memory
  - Temperature and conductivity require 6 bytes
  - Each voltage adds 2 bytes (8 bytes total for 4 voltage inputs)
  - Remote temperature adds 3 bytes
- SBE 21 continues to transmit after memory is full
- Inter-record headers are written at 10,000 scan intervals

## Thermosalinographs (*continued*)

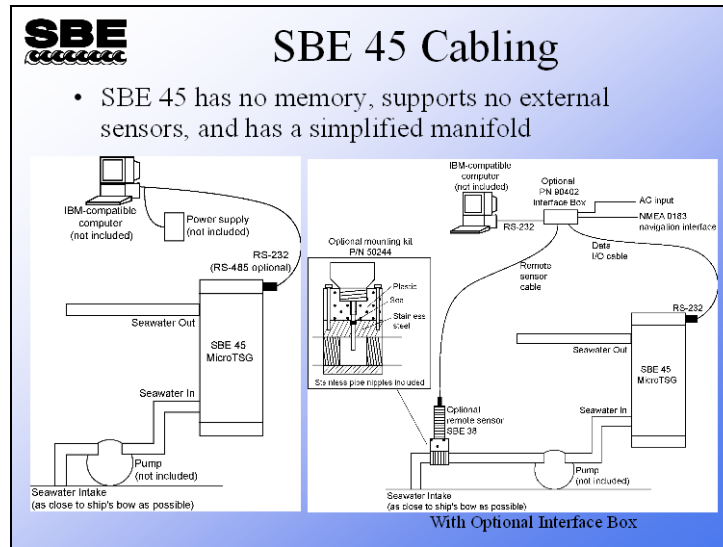

As mentioned previously, the SBE 45 does not have the capability to directly integrate remote temperature or navigational data. However, it can be used with an optional Interface Box, which accepts remote temperature and navigational data, and appends the data to the SBE 45's data stream.

## Thermosalinographs (*continued*)



**SBE 45 Sampling Protocols and Setup**

- Sampling protocols:
  - Polled -- 1 sample is taken and sent to computer
  - Autonomous -- samples are taken on user-input time interval and sent to computer
  - Serial line sync -- pulse on serial line awakens SBE 45; it takes and transmits a sample and goes to sleep
- Use terminal program to:
  - Set time and date and data output (can output sound velocity and salinity, as well as temperature and conductivity)
  - Set sampling scheme and start sampling
- Capture data with terminal program or view it with Seasave

The SBE 45 offers three sampling modes:

- Your computer can ask for a sample; the SBE 45 will take one sample and send it to your computer.
- The SBE 45 will sample at regular intervals and transmit the data.
- A pulse on the serial line (your computer sends a character) causes the SBE 45 to send a sample.



---

## Thermosalinographs (*continued*)

The logo for SBE (Sealed Bore Electronics) features the letters 'SBE' in a bold, sans-serif font, with a stylized wavy line underneath representing water or a liquid surface.

### Thermosalinograph Calibration

- Temperature calibration is best done yearly
- Conductivity calibration depends on the environment that the thermosalinograph is used in
- Comparison to bucket samples or samples drawn off the manifold are best indicator

These are recommendations only; the conductivity calibration depends on the environment that the thermosalinograph is operated in.

## Thermosalinographs (*continued*)



Thermosalinograph  
Maintenance

- Flush with fresh water periodically
- Replace anti-foul cylinders every 6 months
- Rinse conductivity cell with non-ionic detergent weekly
- For prolonged storage of the SBE 21, remove electronics from manifold and loop a Tygon tube from inlet to outlet of conductivity cell

If you have a great deal of biological activity, you should provide more care for your thermosalinograph. Organisms really like pumped systems because they can settle in and have a 24-hour constant flow of seawater past them; it is *little-creature heaven*. Harbors and coastal areas tend to have more contaminants in the water. Use the bucket samples discussed in the last slide to decide when to clean and calibrate you equipment.

## Thermosalinographs (continued)

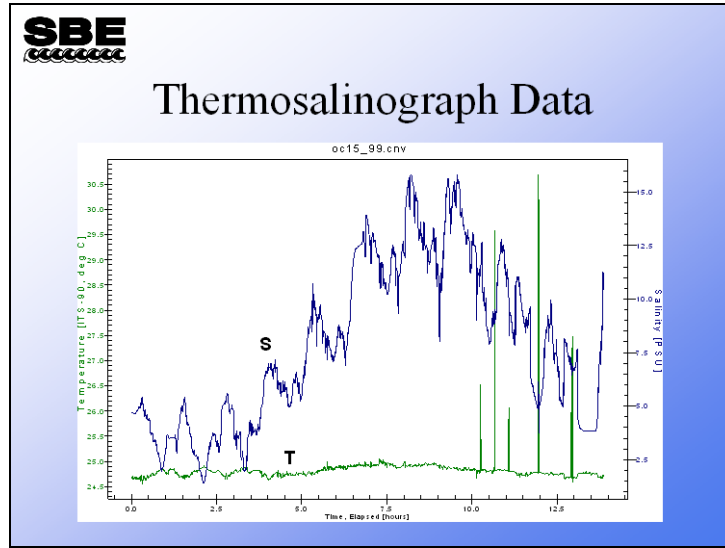

## Thermosalinographs – Example Installation and Data

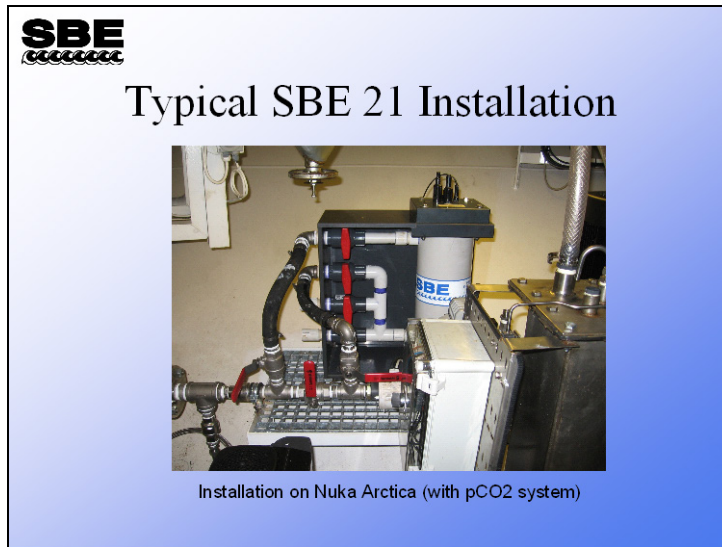

## Thermosalinographs – Example Installation and Data (continued)

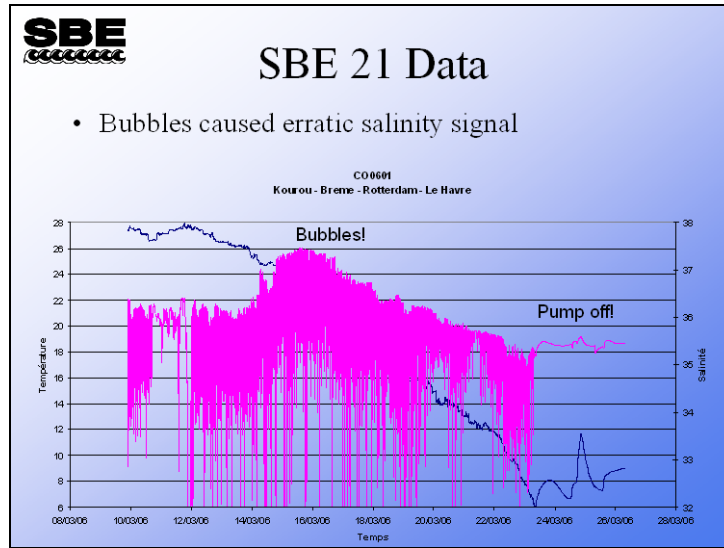

## Thermosalinographs – Example Installation and Data (continued)

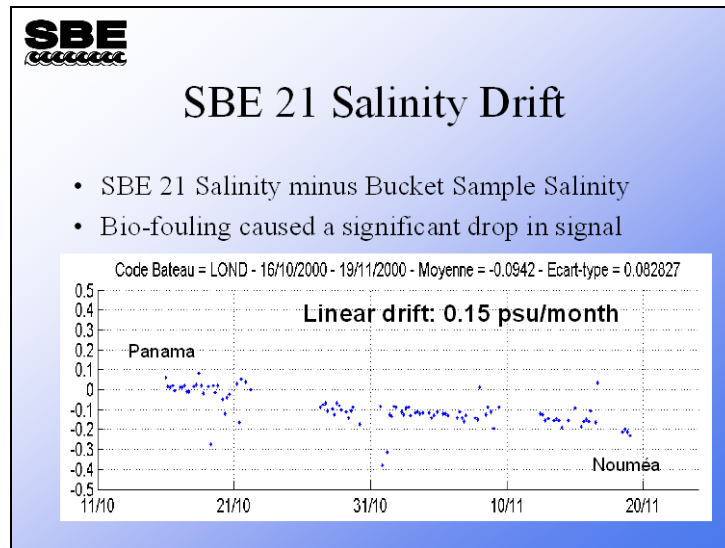

*For sharing his photograph and data with us, we are grateful to Gilles Reverdin, a French scientist of CNRS, working at LOCEAN laboratory in Paris.*